

elektor

up-to-date electronics for lab and leisure

71
March 1981
U.K. 60p
U.S.A. \$2

sound generator

logic analyser

MW receiver

Sumida King



Make it for a Song!



The New **Maplin in Matinée**

**Amazing Value
For Only**

£299.95 + £99.50 for cabinet if required.

Easy to build. Latest technology — means less cost, less components and 80% less wiring. Comparable with organs selling for up to £1,000.00. Two 49-note manuals. 13-note pedalboard. All organ voices on drawbars. Preset voices: Banjo, Accordion, Harpsichord, Piano, Percussion. Piano sustain. Sustain on both manuals, and pedalboard. Electronic rotor, fast and slow. Vibrato and Delayed vibrato. Reverb. Manual and Auto-Wah. Glide (Hawaiian Guitar Sound). Single finger chording plus memory. 30 Rhythms! 8-instrument voicing. Major, Minor and Seventh chords. Unique walking bass lines with each rhythm. Unique countermelody line with each rhythm. Truly amazing value for money. Full construction details start in the March issue of *Electronics & Music Maker* on sale Feb. 14th.



The complete buyers' guide to electronic components. With over 300 pages, it's a comprehensive guide to electronic components with thousands of photographs and illustrations and page after page of invaluable data. Get a copy now — it's the one catalogue you can't afford to be without.

Post this coupon now for your copy of our 1981 catalogue price £1.

Please send me a copy of your 320 page catalogue. I enclose £1 (Plus 25p p&hp). If I am not completely satisfied I may return the catalogue to you and have my money refunded. If you live outside the UK send £1.68 or 12 International Reply Coupons. I enclose £1.25.

E381

Name _____

Address _____

MAPLIN

Maplin Electronic Supplies Ltd.

All mail to: P.O. Box 3, Rayleigh, Essex SS6 8LR

Telephone: Southend (0702) 554155. Sales (0702) 552911.

Shops:

159-161 King Street, Hammersmith, London W6 Telephone: (01) 748 0926

284 London Road, Westcliff-on-Sea, Essex. Telephone: Southend (0702) 554000

Both shops closed Mondays.

Catalogue now on sale in all branches of WHSMITH  Price £1.00

selektor	3-01
multichannel TAP	3-02
J. Meyer	
Touch switches have been rather neglected lately but their simplicity and silence makes their use very practical in many applications. The particular switch in this article is a bank of single pole selectable switches. The printed circuit board features twelve switches but in principle this may be any number.	
the High Com noise reduction system	3-06
This article covers the complete constructional details of the Elektor High Com noise reduction system. The High Com modules will be supplied by Telefunken ready tested and calibrated. The project includes all the extras needed to construct a very high performance system such as a built in calibration oscillator and LED peak meter. The completed unit can be connected directly between the main amplifier and the cassette or reel to reel tape recorder.	
logic analyser	3-18
The analysis of digital signals is not an easy task without the aid of an expensive item of test equipment, namely a logic analyser. Unfortunately, these are invariably priced well beyond the reach of the average enthusiast. All is not lost however, since an ordinary oscilloscope can be coupled with the project featured in this article to produce a very respectable logic analyser.	
sound generator	3-22
However strange a sound effect may be, our readers always seem to be able to find plenty of uses for it. The device featured in this article is able to imitate many sounds from the twittering of birds to machinegun fire, from the screeching of brakes as a car runs out of control to the inevitable crash ... and all from a single IC.	
movement detector	3-30
The electronic movement detector described in this article not only opens doors and switches lights on and off, but can also form the basis of a game — how to sneak out an object from a guarded room.	
medium wave receiver	3-32
Many of our readers belong to the younger generation and there is nothing quite like building your first radio — and getting it to work! — as many of our more experienced readers will know. The object of this article is to end up with a neat economical portable radio that fits comfortably inside a coat pocket.	
text display on the Junior Computer	3-36
from an idea by U. Seyffert	
The display of the Junior Computer is suitable for displaying both numerical and hexadecimal data. By utilising a seven segment alphabet it is also possible to display written texts. If the text is static, a total of six letters are available. If a longer message is required however, this may 'run' along the display.	
traffic game	3-39
To sharpen our reflexes for todays traffic situation, this article describes a game in which everyday problems encountered on the road are simulated by electronic means.	
market	3-42
advertisers index	UK-22

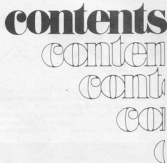

EDITOR:
W. van der Horst

UK EDITORIAL STAFF
T. Day E. Rogans
P. Williams

TECHNICAL EDITORIAL STAFF
J. Barendrecht
G.H.K. Dam
P. Holmes
E. Krempelsauer
G. Nachbar
A. Nachtmann
K.S.M. Walraven

elektor March 1981
UK 03
No. 112



selektor 2010

Hitachi developments

Ultra-thin solid-state batteries

The Hitachi Central Research Laboratory and Hitachi Maxell, Ltd. have recently succeeded in synthesizing a novel high Li^+ conductive solid electrolyte for use in solid-state batteries. This development of the new solid electrolyte will make possible the production of ultra-small or ultra-thin (0.7 mm in thickness or less) batteries having high energy density and a long shelf life without any leakage.



The solid electrolyte is a lithium nitride-iodide-hydroxide type compound. Solid-state micro batteries using this electrolyte show discharge characteristics 100 times or more greater than previous lithium iodide-alumina solid batteries. This dramatic improvement will allow their use in various small electronic equipment such as wristwatches and hand-held calculators.

The Central Research Laboratory and Hitachi Maxell have experimentally produced ultra-thin batteries with a thickness of 0.7 mm and diameter of 20 mm, and have shown their feasibility in practical applications. In the experimental batteries, positive and negative electrodes are formed on either side of lithium nitride-iodide-hydroxide electrolyte pellet, and this unit cell is enclosed in a case having a height of 0.7 mm. The maximum current output of 5 mA is approximately 100 times greater than previous solid-state batteries. When a constant current of two micro amperes is taken, this battery provides a stable electric potential of over 1,000 hours. In the near future, more than 10,000 hours of battery service life can be expected for an electronic wristwatch. This new electrolyte will permit production of batteries which are even thinner than the present prototype battery, and consequently will result in a further increase in performance. Therefore, layer-comprised batteries with large capacity and high power could be manufactured. They are

expected to be eminently suitable in high voltage applications.

As the electrolyte itself is of solid-state type, it is envisaged that IC process technology will be applied in the fabrication of the batteries, eliminating variations in product quality and opening up wide fields of applications for high reliability and low cost micro power sources.

Lightweight portable methanol fuel cells

Hitachi, Ltd. has developed the world's first compact, portable methanol fuel cells as a power source for such areas as home appliances and agricultural and engineering equipment.

The development of a new type electrode has made possible a three-fold increase in power output compared to conventional methanol fuel cells. The new fuel cells weighing only half that of an automobile lead-acid battery of the same size are a high-performance 12 volt, four ampere unit. It can be used to power VTRs and other home appliances for use outdoors as well as pumps and blowers for agriculture and engineering projects. Demand for the new cell is increasing as it is a compact, lightweight power source and can be used for long hours.

Fuel cells that have been developed in response to such needs generate energy through the reaction of an oxidizing agent with the fuel. It is a kind of direct current generator that works so long as there is a supply of fuel.

Hitherto, the methanol fuel cell had been considered best as a portable energy source, but its practical application had been stymied by the low voltage per electrode and the small electric current density.



Hitachi, Ltd. developed an electrode to activate the reaction using a platinum ruthenium catalyst in place of the conventional platinum single catalyst. As a result, single cell voltage was increased to 0.4 volts and electric current density three times to 60 mA/cm².

Furthermore, with the development of a new battery structure using ion exchange film as an electrolyte, the

new, compact fuel cells have a generating capacity of 12 volts, four amperes. Hitachi will continue research and development of the methanol fuel cells for its practical application.

Main specifications:

1. Dimensions: 227 mm (width) x 195 mm (length) x 127 mm (height)
2. Weight: 6.3 kg
3. Rated voltage and ampere: 12 V, 4 A

(632 S)

More on noise reduction

less noise on records

The number of noise reduction systems available on the market nowadays is bewilderingly high and makes it all the more difficult to make a suitable choice. The survey here attempts to clarify the latest situation with regard to records and record players.

CBS recently came up with a very interesting design for reducing noise on records. It is not available as yet, but promises to be highly effective. It is claimed to totally eliminate any noise caused by the surface structure of the grooves (surface noise) and improve the dynamic range considerably. CBS claim that the new noise suppressor will enable records to sound as good in quality as analogue and digital master-tapes. The system should achieve as much as 85 dB signal to noise ratio and could therefore also be used on tape recorders.

As if that weren't enough, the system has the added advantage that LP's recorded with it are compatible to standard equipment (even without a corresponding decoder). In other words, the sound will be improved on an ordinary record player. This was certainly not possible using the well-known Dolby, HighCom, DBX, Anrs, etc systems. The CBS decoder is expected to be highly competitive in price.

Naturally, the Dolby laboratories have not been resting on their laurels. Their technicians set to work as soon as the High Com from Telefunken appeared, for noise reduction has always been this company's speciality. The recently introduced Dolby C system seems to be one step further in the evolution of the well-known Dolby B compander. It has caught up with the competition by suppressing up to 20 dB of noise. It is, however, a great deal more complex than the B compander and it is doubtful whether the one can be used instead of the other. Although 'normally' dolbysed cassettes may be played on a C compander system this is not true of C dolbysed cassettes on the 'old' B version, which may mean having to buy a new cassette recorder.

Similarly to the B version, the Dolby C compander is a 'sliding band' type using an IC manufactured by a well-known American company.

(628 S)

J. Meyer

It is high time that Elektor devoted space and attention to TAP switches. Their simplicity (and silence) makes their use very practical in many applications.

It will be apparent from the heading that the TAP in question is a multichannel set with single point touch contacts. In other words the switch will be operated by touching a fixed button or contact point with a finger. As mentioned before, there may be any

again. This brings us to the reset circuit: When one of the contacts (say, contact no. 1) is touched and the corresponding output has become '1', a voltage of

$$\frac{R5}{R5 + R42} \times (U_B - 0.7),$$

$$\text{or } \frac{33}{133} \times (U_B - 0.7):$$

which is about $0.23 \times U_B$ (U_B representing the supply voltage of the circuit),

multichannel TAP

the elegant touch

The TAP (Touch Activated Programmer) switch is 'in' again. Touch activated switches have been rather neglected lately, but, since the rise in popularity of the electronic clock, more and more manufacturers are beginning to include them on all sorts of devices.

The particular switch in this article is a bank of simple single pole selectable switches (SSPSS?). The standard version features twelve touch activated switches but in principle this may be any number. Only one button at a time can be 'switched on'. This means that the system is ideal for use in tuners, for instance, where a number of stations are to be preselected.

number of switches although the twelve on the printed circuit board of this version will be sufficient for a variety of applications. Of course, if more are required, several boards may be linked together to construct a 24 or even 36 channel TAP.

The boards are very reasonable, as far as their constructional cost is concerned, and the interlocking switch bank uses very little current. This is due to their only requiring one CMOS gate each and after all, a 4071 IC contains four as it is.

The circuit diagram

The circuit involves very little in the way of sophisticated electronics. On the face of it, it looks complicated only because the same circuit has been drawn twelve times.

The twelve touch contacts are shown one above the other to the left of the diagram. Their corresponding outputs are drawn at the right-hand side. The switches themselves each consist of four resistors, two diodes and an OR gate (N1...N12). At the bottom of the circuit IC1 and T1 can be seen. These are included to ensure that when a contact is touched all the others are included to ensure that when a contact is touched all the others are reset thus allowing only one output to be high at a time.

The circuit works as follows:

When one of the contacts is touched both the input and the output of the OR gate corresponding to it will become logic one. Since the output is coupled to the other input of the gate via a resistor (R30...R41), the output will be latched, that is it will continue to remain high even when the touch contact is released. Diodes D13...D24 prevent the output high level from affecting one of the other gates.

So far so good. The next thing to achieve is that as soon as another contact is touched, the output of the previous contact will become low

will fall across resistor R5. A higher voltage level, however, will be on the wiper of P1 (as will be explained below), so that the output of comparator IC1 will be low. Transistor T1 and diodes D1...D12 will now no longer conduct. Thus, nothing else will happen. If after this a second contact is touched (let's say contact no. 2, for instance), the corresponding output (i.e. N2) will again become logic 1. A higher voltage will therefore fall across R5. In the formula given above, the value of R42 (100 k) must now be replaced by the value produced by the parallel circuit of R42 and R43 (=50 k). This gives

$$\frac{33}{83} \times (U_B - 0.7),$$

thus about $0.37 \times U_B$.

If the voltage across the wiper of P1 is set between the two values to about $0.3 U_B$, the output of the comparator will go high when the second contact is touched. T1 will then conduct and reset all the gates via diodes D1...D12, except that one belonging to the contact being touched. In other words, the output of the last contact to be touched will be the only one to remain high. Setting P1 to $0.325 U_B$ can be done with the aid of a multimeter although if one is not available, setting P1 in the middle position will probably be close enough.

There's more than meets the eye...

Readers with sharp eye-sight will have undoubtedly spotted all sorts of 'extra' odds and ends on the board which were not included in figure 1. Well, since the gates belonging to IC 4071 must not be overloaded (somewhere in the region of 0.25...1.5 mA) room has been made on the board for adding twelve buffer stages without making

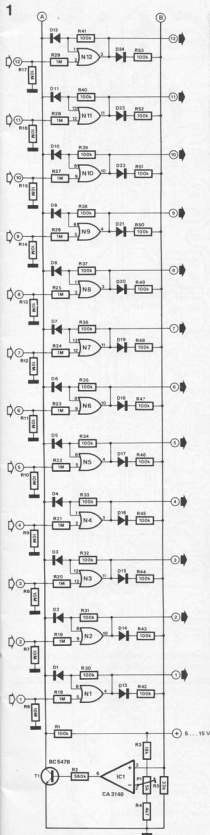
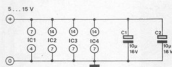
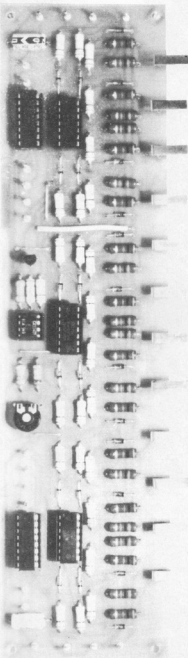

Figure 1. The TAP circuit diagram. The touch activated switches are built up around N1...N12. IC1 and T1 provide the automatic reset.



N1...N4 = IC2 = 4071
 N5...N8 = IC3 = 4071
 N9...N12 = IC4 = 4071
 D1...D24 = 1N4148

Table 1.

4049/4050	U_b	I_{out}	U_{out}
output	5 V	-2,5 mA	2,5 V
high	10 V	-2,5 mA	9,5 V
(Source)	15 V	-10 mA	13,5 V
output	5 V	6,0 mA	0,4 V
low	10 V	16 mA	0,5 V
(sink)	15 V	40 mA	1,5 V

Table 1. The output current capability of each channel when the buffers of inverters of figure 2a or 2b are used.

Table 2.

4071	U_b	I_{out}
output	5 V	-0,25 mA
high	10 V	-0,5 mA
(Source)	15 V	-1,5 mA
output	5 V	0,25 mA
low	10 V	0,5 mA
(Sink)	15 V	1,5 mA

Table 2. The output current capability when the wire links of figure 2c are used to replace the buffers.

the circuit more expensive. By using inverters as buffer stages, an inverted version of the multichannel TAP is obtained. When a contact is touched its output will now become low, whereas all the others will be high, instead of the other way around.

Figure 2 shows what happens in the buffer stages. The twelve outputs of figure 1 are linked to the inputs of two IC's, either the 4050 as standard or the 4049 for the inverted version. They each contain 6 gates, so together just the right number for the 12 channels.

Table 1 indicates the output current of the 4049 and 4050 ICs at three different supply voltages. Here it should be noted that when the outputs are to produce current (on output high source) the maximum current will be considerably less than a current 'sink'.

If buffer stages are not required IC5 and IC6 can be omitted and the six wire links indicated in figure 2c are mounted in the sockets meant for them. The output current is then as shown in table 2.

Construction

Figure 3 shows the copper track layout and component overlay of the 12 channel TAP board. Little need be said about the construction, as this is simple and should not be a problem.

Since the points marked A and B in the diagram have been made easily accessible on the board, the number of channels can be extended without difficulty. A second board can be connected to the links and then of course R1...R5, P1, IC1 and T1 will no longer be necessary. You don't necessarily have to have as many as twelve channels, either. In that case, the parts for the superfluous channels are merely left out and the inputs of the gates that are not used are grounded. If only 8 or 4 channels are needed, one or two 4071 ICs may be omitted altogether.

The touch contacts themselves can be made in various ways (at least where the mechanical side is concerned). The most practical method is to etch a number of finger-tip-size squares with enough space between them to avoid mistakes during operation. Better still buy the contacts ready-made in the various sizes available. For real economy, drawing pins will also do!

The circuit can be fed by means of a simple, stabilised supply. Current consumption depends on the load at the outputs. The value of the supply voltage is not critical; this may range from 5 V...15 V. As shown in tables 1 and 2, this value will, however, affect the output current. It should be noted that the supply must not be connected to the mains earth, as this will prevent the switches from working at all.

A final remark

The circuit can easily be modified to allow the outputs of all the contacts touched to remain high until the circuit is reset by way of another contact. If D13...D23 and R42...R52 are omitted and the wiper of P1 is turned clockwise until it can go no farther (towards R4), contacts 1...11 can each be made high in turn (or low, with the addition of figure 2b) and then contact 12 will act as the reset. This could be very useful. M

2

a

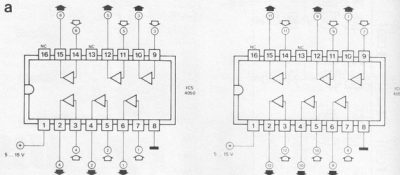

b

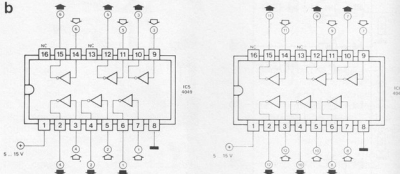

c

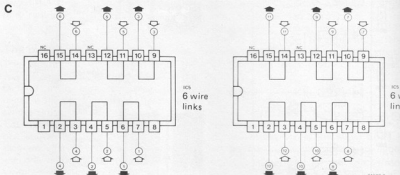

Figure 2. On the board there is room to connect a buffer (2a) or a buffer/inverter (2b) behind every output. If this is not required, IC5 and IC6 may be substituted by a series of wire links (2c).

Parts List

Resistors:

R1, R30...R53 = 100 k
 R2 = 560 k
 R3 = 18 k
 R4 = 4k7
 R5 = 33 k
 R6...R17 = 10 M
 R18...R29 = 1 M
 P1 = 5 k preset potentiometer

Capacitors:

C1, C2 = 10 μ /16 V

Semiconductors:

T1 = BC 547B
 D1...D24 = 1N4148
 IC1 = CA 3140
 IC2, IC3, IC4 = 4071
 IC5, IC6 = 4049 or 4050
 (or 6 wire links)

3

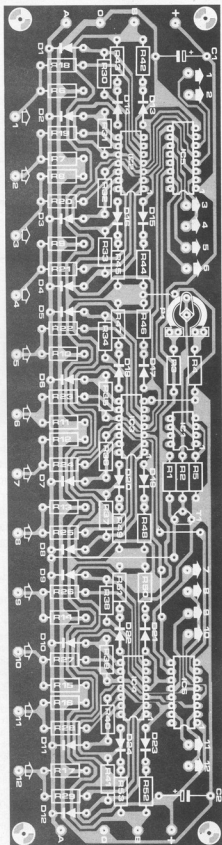
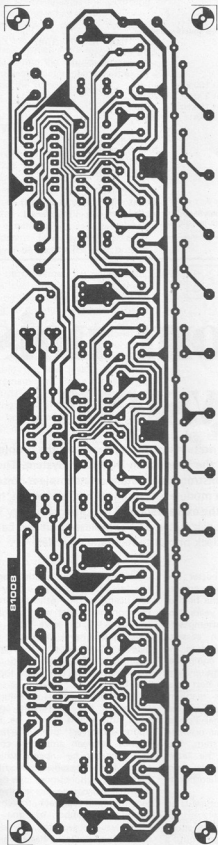

Figure 3. There are 12 channels on the board. This number may be extended by way of the connection points A and B (see figure 1).

High Com technical specifications:

Frequency range:	20 ... 18000 Hz (+0, -3 dB)
Distortion:	< 0.2% at 1 kHz
Signal/noise ratio:	> 80 dB (DIN input) > 85 dB (socket input)
noise reduction at 100 kHz:	15 dB
at 3 kHz:	20 dB
at 15 kHz:	25 dB
DIN-A:	20 dB
Input sensitivity	
DIN recording:	0.6 mV across 6 k Ω
socket recording:	200 mV across 25 k Ω
DIN playback:	130 mV across 79 k Ω
socket playback:	200mV across 100 k Ω
output voltage	
DIN recording:	1 mV/k Ω
socket recording:	600 mV (5k6 output impedance)
DIN and socket playback:	0-1.5 V (5k6 output impedance)

the High Com noise reduction system

The previous issue of Elektor included a general discussion on noise reduction systems and the problems involved for the home constructor. Featured in the article was the Telefunken High Com System. The present article is a continuation of the above and covers the constructional details of a complete noise reduction system for the electronics enthusiast. The High Com modules, as supplied by Telefunken, have been incorporated on a printed circuit board that includes all the extras required to construct a very high performance system, such as a calibration oscillator and LED peak meter. The completed unit can be connected directly between the main amplifier and a cassette deck or reel-to-reel tape recorder.

The continued search for better and better Hi-fi performance has created important developments in the field of audio technology in recent years. Not the least of these are the attempts to improve the noise level in cassette recorder systems. As discussed in the previous article, a number of companies have spent a great deal of money and effort to try and obtain the best possible performance from this medium. One of the leaders in this field is Telefunken with their professional Telcom C4 system and the consumer oriented version, the High Com system. The excellent specification of the latter system has encouraged more and more recorder manufacturers to incorporate it into their cassette decks.

The High Com system also presents an interesting possibility for the electronics enthusiast since all the principle active components have been integrated onto a single chip, the U401B. This, of course, means that the noise reduction system is now fairly straight forward to build. Where is the snag? There has to be one,

and the disadvantage here is the fact that the ICs are only available to licensees, in other words, your component retailer will not have them in stock. To solve this problem Telefunken have made an exclusive agreement to supply Elektor readers with completed, tested and calibrated modules which include the elusive U401B.

The Elektor system is, of course, based firmly on the Telefunken application since this could hardly be improved upon. However, the 'interface' electronics between amplifier, compander and recorder have been subjected to some fairly extensive modifications. Electronic switches now take care of the entire signal conversion involved during recording and playback, thereby cutting down the number of long screened cables usually required. In addition, a calibration oscillator has been included to allow accurate adjustment of the signal levels between the noise reduction system and the recorder. A further refinement is the inclusion of a LED

peak meter which enables the recording level to be monitored at all times. Before going on to describe the complete circuit a closer look at the theoretical details, which were mentioned in passing last month, would help in a better understanding of the Elektor noise reduction system.

In theory

The usable dynamic range of a magnetic tape recorder is limited by the onset of overdrive at one end and by the inherent noise level at the other end. When a signal with a dynamic range greater than the bandwidth of the tape is recorded, there will be frequent overdrive excursions at peak signal levels and important low level signal components will be lost in the ever present noise.

This can be prevented by compressing the signal level during recording, thereby reducing the dynamic range, and by expanding it during playback to bring it back up to its original value. Provided that precisely opposite operations are performed by the expander, the original dynamic range can be restored. This ensures that the low level signal components remain well above the noise, in other words, the noise level is effectively reduced. The upper threshold level can be regulated by the operator with the aid of (peak) modulation meters. In any case, the dynamic range is effectively increased, which is exactly what is required in a cassette deck.

Figure 1 contains a simple block diagram of a compander (compressor + expander = compander). Blocks A and B are voltage controlled amplifiers where the transfer function can be expressed as follows:

$$A(U_2) = \frac{U_2}{U_1}$$

$$B(U_3) = \frac{U_4}{U_3}$$

From this it can be seen that the transfer function of amplifier A is determined by its output voltage, and that of amplifier B by its input voltage. The output voltage U_4 will have to be equal to that of the input voltage U_1 for the recording to be high fidelity. This can also be expressed as:

$$B(U_3) = A^{-1}(U_2).$$

In other words, the transfer function of the expander must be the exact inverse of that of the compressor. This should not be a surprise to anyone! The question now is how to obtain this 'reciprocal' transfer function. Use of one of the numerous high performance operational amplifiers that are readily available these days should make it a fairly easy matter to solve this problem. If as in figure 1c, the expander is included in the negative feedback path

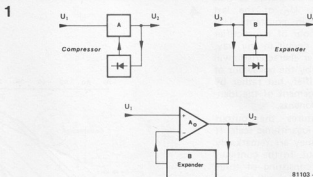

Figure 1. A simplified block diagram of basic compressor/expander circuits. The third illustration shows how a compressor can be formed by placing an expander in the negative feedback loop of an opamp.

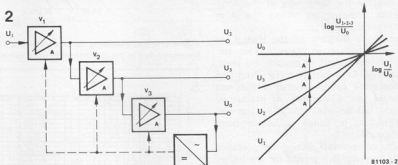

Figure 2. An illustration of the principle of three cascaded voltage controlled amplifiers with a rectifier and a graph showing the characteristics of the circuit.

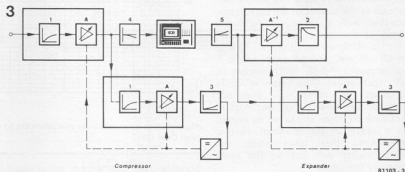

Figure 3. The block diagram of the High Com compander.

of the opamp, the following transfer function will be obtained:

$$A = \frac{A_0}{1 + A_0 B} = \frac{1}{\frac{1}{A_0} + B}$$

Where A_0 stands for the open loop gain of the opamp and B represents the transfer function of the expander. Assuming the open loop gain of the opamp to be infinite, the transfer function expression simplifies to:

$$A = \frac{1}{B}$$

This is precisely what we are looking for, especially seeing that in practice the open loop gain of a good operational amplifier will be large enough to come very close to this equation.

Figure 2 shows a cascade circuit of a number of identical amplifiers as used in both the High Com and the Telcom C4 noise reduction systems. A total of three VCAs are used in the Telcom system and two are used in the High Com system.

The output signal, U_0 , of the third amplifier is converted by a rectifier into a control signal for all the amplifiers. The amplification factor, A,

of the amplifiers is controlled so that the output voltage U_O of the last amplifier will remain constant. This prevents the behaviour of the rectifier from affecting the circuit in any way. Thus, the compander characteristic will not be determined by the behaviour of any particular rectifier, but rather by the cascaded arrangement of the identical amplifier components.

Figure 2 also features the output characteristics on a logarithmic scale. It will be seen that they are remarkably linear at each output. In the configuration drawn here consisting of three amplifiers the input signal will be compressed by amplifier A_1 by a factor of three. If the output signal has a dynamic range of 90 dB, it will be reduced to 60 dB (curve U_2). The expander works in exactly the same way as the compressor, although of course, the other way round.

The block diagram of the High Com circuit is shown in figure 3. Two amplifiers connected in cascade are used. The High Com system differs from the Telcom C4 system in that it does not operate on a number of frequency bands, but on one band only. For this reason it is called a broad band compander.

Each compressor section is preceded by a pre-emphasis circuit for the higher frequencies. De-emphasis then takes place in the expander in order to compensate for this. To prevent the tape from being overdriven at high frequencies two further measures have been taken. A fixed treble cut is performed at the output of the compressor together with a corresponding treble boost at the input to the expander. This is designed so that a 10 kHz signal will not be attenuated unless it has exceeded -8 dB (with respect to full modulation). The graph in figure 4 shows that compansion does not cover an unlimited range, but does in fact have an upper and lower threshold. As a result of the pre-emphasis and de-emphasis that takes place, the characteristics will not be the same for every frequency.

One important feature of the High Com system has yet to be mentioned. The operation of the system is not affected by idiosyncracies in the frequency characteristics of the recorder. Figure 5 illustrates the effect obtained. Curve number 1 represents the noise spectrum characteristics of a cassette tape without the compander and curve 2 shows the characteristics for a cassette tape with the High Com system in circuit. As can be seen, the results are quite impressive.

The High Com IC

Constructing a circuit from the block diagram in figure 3 using only discrete components would be rather a laborious task. Fortunately, Telefunken have integrated all the necessary active com-

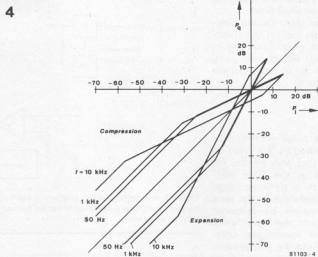

Figure 4. A graph showing the characteristics of the High Com compander. These vary with frequency due to the application of pre-emphasis and de-emphasis.



Figure 5. The noise spectrum characteristics of a cassette tape without compander (1) and with High Com (2).

ponents for the entire compressor/expander circuit onto a single monolithic chip, the UB401. Only a few capacitors and resistors have to be added separately.

The circuit diagrams in figures 6 and 7 show the IC and its internal structure as given in the block diagram. This enables us to see what happens to the signal as it passes through the various parts of the system. Figure 6 provides the circuit diagram for playback and figure 7 for recording. The resistors and capacitors marked with an asterisk need to have a tolerance of 2% and 5% (or better) respectively. The power supply requirement for the High Com IC is 15 V (pins 2 and 1).

The voltage gain of the internal low noise amplifier A is fixed during manufacture at 30 dB. This amplifier is only used during playback. The operational

amplifier following it is connected as a non-inverting amplifier (also with a fixed amplification factor). Finally, the gain of opamps C and D is determined by resistors R7 and R11. Using the given values, their gain will be approximately 5.6.

Expander

Now let us see what happens during expansion (playback in figure 6). The output signal of the tape recorder passes to amplifiers C and D via amplifier B and the RC network between pins 16 and 17. Resistors R8 and R9 and capacitor C9, together with amplifier D constitute an active low pass filter for expander de-emphasis (block 2 in figure 3). The integrated electronically controlled potentiometer between pins 16 and 17 adjust the gain of the filter stage. The external components R17,

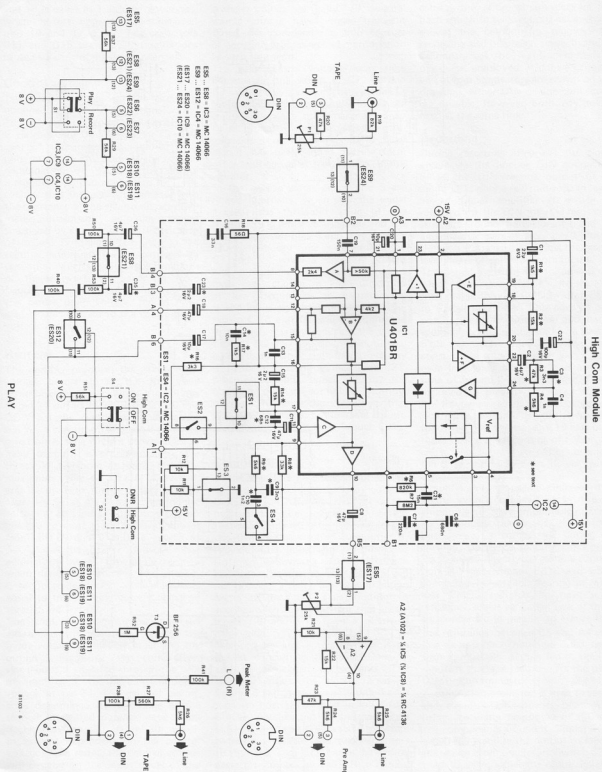

Figure 6. The circuit diagram for the Elektor High Com in the play mode. Pin numbers are for the left hand channel with the right hand channel numbers shown in brackets.

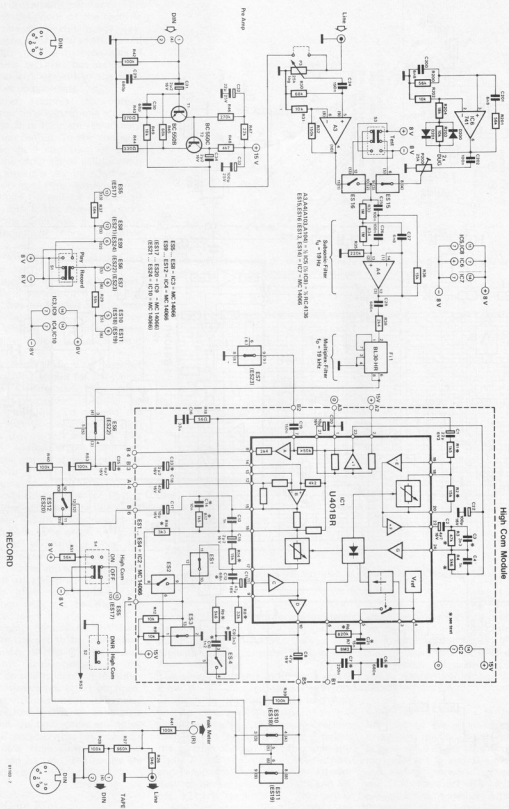

Figure 7. The circuit diagram for the Elektor High Com in the RECORD mode. The circuit and components inside the broken line in both circuit diagrams are those contained in the Telefunken High Com module.

R18, C13, C14 and C16 comprise the treble boost during playback (block 5 in figure 3). The gain between pins 14 and 10 is equal to 1 at low frequencies, when the total impedance seen between pins 16 and 17 is 3 k. The capacitors C11 and C15 prevent DC fluctuations caused by control resistance changes.

Control voltage

The control voltage for the circuit is obtained from the output signal at pin 16. This signal is fed to amplifiers E and F via capacitor C1 and resistor R1. The gain of the inverting amplifier E is determined by the ratio of the parallel combination of R2 and the second integrated potentiometer to R1. It follows that the gain will decrease with the resistance of the electronic potentiometer. Subsequently, amplifier F boosts the signal by a factor of ten. The output of opamp F (pin 22) is routed to the rectifier amplifier G via a passive high pass filter which combines the functions of the networks (1) and (3) from figure 3. Since the rectifier operates at the centre point voltage, pin 24 must also be tied via R4 to the centre point voltage at pin 23.

Rectifier

The rectifier produces the gain control voltage according to the full wave threshold principle. When the voltage at pin 24 differs by more than ± 70 mV DC from the centre point voltage at pin 23, a current sink circuit is switched on at pin 6. The current delivered internally to pin 1 is proportional to the threshold overshoot at pin 24 until the maximum value of 2.5 mA is reached, and is used to discharge the storage capacitor C7 at pin 6, thus changing the voltage at this pin. Capacitor C7 is recharged towards more positive voltages from the reference voltage source at pin 4, via the R6/R7 network. The equilibrium at pin 6 will be reached when the integral current flow into pin 6 produced by threshold overshoots is equal to the charging current delivered through R6 and R7.

The control voltage throughout the entire circuit is determined by both the input voltage of the expander and the output voltage of the compressor, since both are related through the gain of amplifier E to the constant input voltage at pin 24. The gain of opamp E is determined by the value of the second integrated potentiometer (connected between pins 18 and 20), which in turn is dependent on the control voltage. As a result, the control voltage will depend on the input signal of the circuit, in spite of the constant voltage to the rectifier. The control voltage range for amplifiers C and E is designed to be 30 dB.

The shortest response time of the rectifier to a positive step change of input voltage is determined by the value of the storage capacitor C7 and the

maximum current available from the current sink at pin 6. This time reaches 0.3 ms for full swing of the gain control voltage. Since virtually all natural sound effects have longer transient times, the compander is thus capable of accurate processing and reproduction of such transients.

The gain control voltage decay time depends on the values of C7, R6 and R7. Obviously, a short decay time is preferable for the compander to operate well, but on the other hand this may cause signal distortion at low frequencies. For this reason, a delay circuit has been added in the form of a retriggerable monostable multivibrator.

In the passive state, pins 4 and 5 are linked internally. When ever the signal exceeds the threshold value of the rectifier, the MMV is triggered and the switch between pins 4 and 5 is opened. Thus, the decay time is determined by C7 and R7 when a signal is present and the values of these components have been chosen to keep distortion at low frequencies to a minimum. If the input signal terminates abruptly, resistors R6 and R7 will be connected in parallel, thereby reducing the decay time. If the duration of the input signal is less than that of the MMV the decay is further reduced by means of C21. When the input signal returns, the charging current continues to flow through R6 for a short while so that the decay time does not increase abruptly, but rather rises slowly through C21.

Compressor

Little needs to be changed for the IC to be used as compressor (see figure 7). Basically, all that is required is to incorporate the expansive section (between pins 15 and 10) within the negative feedback loop of amplifier B. Provided the impedance at pin 12 is sufficiently low, the interval feedback resistance between pins 12 and 15 will no longer affect the amplification factor of opamp B. This condition is accomplished by ensuring that capacitors C8 and C18 have a relatively large value.

That covers just about all that is required concerning the High Com IC and its associated components. The circuitry inside the dotted areas of figures 6 and 7 has been mounted on a separate board. This also includes four CMOS switches yet to be mentioned (ES1, 2, 3 and 4). These serve to switch between a resistor and two capacitors (R16, C10 and C12) enabling Dolby cassettes to be played. Real Dolby expansion is of course too much to expect, but the circuit comes very close to achieving it.

Circuit diagram

Very little needs to be added to the High Com IC and its associated com-

ponents (see inside the dotted area) in order to produce an excellent noise reduction system. For the sake of clarity, the entire circuit diagram has been split into two sections in which are shown the components required for recording and playback, respectively. In both instances, the High Com module is, of course, employed. A choice of input and output connectors are shown on the drawings, either DIN or line connectors are suitable. However, both may not be used at the same time.

Recording

During recording (figure 7) the signal enters via the line or DIN connector. Since the DIN record output of an amplifier is only a few millivolts in level, an additional amplifier stage will be required for the DIN input. This is constructed around transistors T1 and T2 and gives a gain of around 70. Potentiometer P3 is used to adjust the record level and is effective on both inputs.

The signal is then fed to opamp A3 which has a gain of five. The signal is then passed through CMOS switch ES14 to a high pass filter. This consists of a notch filter (amplifier A4 and corresponding components) and of a passive 6 dB per octave filter. Together they constitute a subsonic filter with a turnover frequency of 19 Hz and a decay time of around 24 dB per octave. This is included to prevent interference from low frequency signals during calibration. The multiplex filter BL30-HR (or HA) following it suppresses any 19 kHz pilot tones during the recording of FM broadcasts. The signal then passes to amplifier B of the High Com IC via switch ES6.

Amplifier A is not used during recording as the input signal level is of sufficient amplitude to drive amplifier B directly. As previously mentioned, the U401B operates as a compressor during recording, since the module connection B5 is linked directly to module connection A4 via switches ES10 and ES11 connected in parallel. Bearing in mind that CMOS switches do have some resistance, albeit very low, two of them are connected in parallel to ensure that the resistance between B5 and A4 is as low as possible. The compressed signal from output B6 is then fed to the line input of the tape recorder via the usual DIN or line connector.

A calibration oscillator is used to set up the circuit. This consists of a Wien bridge oscillator composed of IC6 and the components around it. Diodes D200 and D201 stabilise the output voltage of the calibration oscillator. Switch S3 is used to select either the input signal or the calibration signal of 400 Hz. The calibration procedure itself will be dealt with in greater detail later.

Playback

Figure 6 illustrates the playback circuit diagram. Compared to the recording

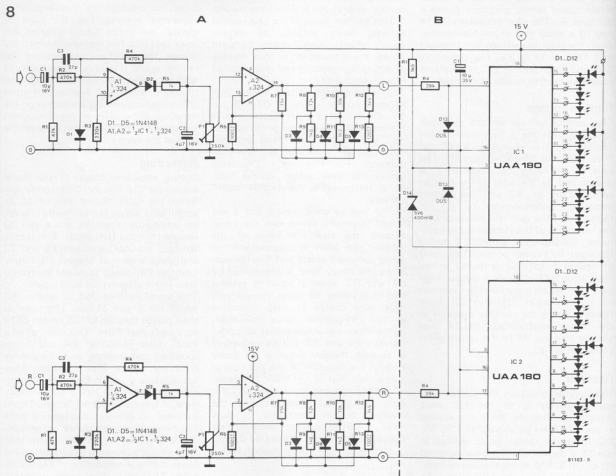

Figure 8. The circuit diagram for the peak meter. The section to the right of the dotted line is the display section.

version it is very straight forward. The output of the tape recorder is connected to the line or DIN input socket. The input signal level is preset by potentiometer P1 before reaching amplifier A. The output of this amplifier is connected to the input of amplifier B by way of switch ES8. In the playback mode, the U401B is used as an expander (the link between module connections B5 and A4 no longer exists). The expanded output signal then fights its way through to the output at B5 and is passed to the buffer amplifier A2. The signal can now be fed to one of the main amplifier's line or DIN inputs (whichever is available) by way of one of the two output sockets. The tape sockets in the lower right hand corner of the circuit diagram are included so that transfer to a second tape deck is possible.

The on/off switch for the High Com system, S4, is shown in both circuit diagrams. Switch ES12 closes when the system is switched from recording to playback and effectively short circuits the internal feedback resistor of amplifier B. At the same time, switches ES10 and ES11 are opened, thus breaking the connection between B5

and A4. Thus, neither compression nor expansion will occur.

Switch S2 selects between High Com and DNR during playback. DNR gives a similar result to that of DOLBY. In other words, cassettes taped with DOLBY can be replayed on the High Com system. The DNR position is not functional in the record mode even though S2 is included in both circuit diagrams.

Peak meter

The circuit diagram of the peak meter is given in figure 8. This is a design that was first published in the January 1978 (E33) issue of *Elektor* with the printed circuit board number EPS 9827. The component values have of course been modified to suit this particular application. The circuit around amplifier A1 constitutes a peak detector which measures the peak amplitude of the input signal. The circuit around A2 is the converter that provides a linearly increasing voltage with logarithmic display using LEDs controlled by the well known UAA 180 IC. Preset potentiometer P1 sets the sensitivity of the modulation meter. The input of the

peak meter is connected to module output B6, via resistor R41.

Power supply

The power supply (see figure 9) for the *Elektor* compander makes use of integrated voltage regulators. This circuit although simple is very effective. The High Com IC and the peak meter require +15 V and the remaining op-amps are fed with ± 8 V. LED D5 has been included as a mains 'on' indicator.

Construction

The printed circuit boards for the various circuits are shown in figures 10...14. The system consists of a main board and two modules. In addition there is a board for the peak meter, two boards for the LED display and finally the power supply board. The High Com modules include the U401B and are supplied ready built (more about this later).

As is usual, all the printed circuit boards and their components should be assembled and checked. Then, before any wiring takes place, the finished boards, mains transformer, switches and sockets etc. are fitted into the case.

Sockets can of course be DIN or phono to be compatible with the rest of the audio system. Having made sure that all the hardware fits together, wiring can commence. The switches can be wired as shown in figures 6 and 7 using only ordinary cable. Since the control switching is electronic only DC levels are involved and therefore screened cable is not necessary. The big advantage with this arrangement is that the earth loop problems that usually occur with screened leads do not arise. The pin numbers for the DIN socket connections are given in the circuit diagrams (figures 6 and 7). These refer to the left hand channel, the right hand channel being the numbers in brackets. A total of two DIN or eight phono sockets will be needed.

The illustration in figure 15 shows the design of the front panel layout. Due to practical reasons it is not reproduced here in full size.

Before connecting the power supply to the rest of the circuit, it will be as well to first check to ensure that it operates correctly. It should supply output voltages of plus 15 V and plus and minus 8 V. If all is well the power supply connections can be made to the printed circuit boards, after disconnecting from the mains . . .

The CMOS switches, IC's 3, 4, 7 and 9 can now be inserted and checked (with the power on). Although they look like IC's (because, of course, that is exactly what they are) they really do operate like a normal switch and can be checked in the same manner. Practical proof can be provided by connecting the ohmmeter probes to the pins of the electronic switch to be tested and operating the corresponding panel switch. The meter reading should change from zero resistance to infinity (or vice versa). Pin numbers are again given in figures 6 and 7 with the right hand channel in brackets. When ES8 and ES21 are tested, one side of each of these electronic switches will have to be temporarily grounded with a 10k resistor.

If all goes well, the remaining IC's can be (turn the power off first!) placed in their sockets. The voltages at the supply pins of the IC's should now be measured just to be on the safe side.

The peak meter and display board supply can be linked up next and its

9

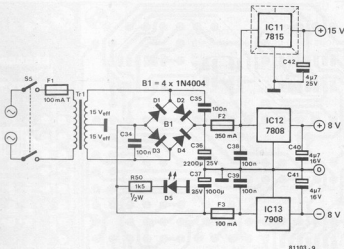

Figure 9. The circuit diagram for the power supply.

10

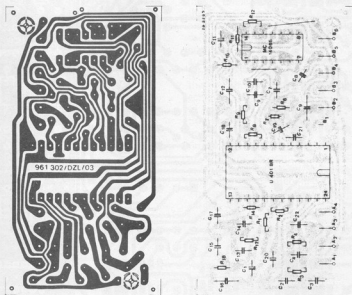

Figure 10. The layout of the main board is double sided, it is NOT plated through and therefore components will have to be soldered on both sides of the board where necessary. This may be inconvenient but it goes a very long way to keeping the cost of the board down.

Parts list for the High Com module:

Resistors:

R1 = 1k5/2%
 R2, R14 = 15 k/2%
 R3 = 47 k/2%
 R4, R9 = 5k6/2%
 R6 = 820 k/2%
 R7 = 8M2
 R8 = 33 k/2%
 R11, R12 = 10 k
 R16 = 3k3
 R17 = 1k5/2%
 R18 = 56 Ω

Capacitors:

C1 = 22 µ/6V3
 C2 = 4µ7/16 V
 C3, C9 = 3n3/5%
 C4, C13 = 1 n
 C6 = 680 n/5%
 C7 = 220 n/5%
 C8, C11, C18 = 47 µ/16 V
 C10 = 1n2/5%
 C12 = 68 n/5%
 C14 = 10 n/5%
 C15, C23 = 2µ2/16 V
 C16 = 33 n
 C17, C20 = 10 µ/16 V

C19 = 150 n

C21 = 15 n/5%
 C22 = 100 µ/16 V

Semiconductors:

IC1 = U 401BR
 IC2 = MC 14066, CD 4066B,
 HEF 4066B

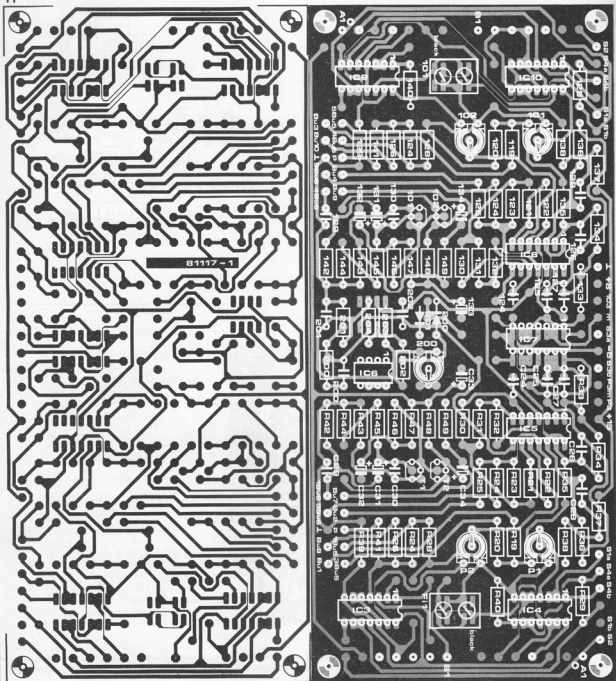

Figure 11. The boards for the High Com modules are complete with components and calibrated.

Parts list for the main board:

Resistors:

R19, R119 = 82 k
 R20, R120, R23, R123 = 47 k
 R21, R121, R202, R203, R31,
 R131 = 10 k
 R22, R122, R36, R136 = 15 k
 R24, R124, R25, R125, R26,
 R126 = 5k6
 R27, R127 = 560 k
 R28, R128, R39, R139, R40, R140,
 R41, R141, R42, R142, R50,

R150, R53, R153 = 100 k
 R29, R129, R37, R137, R51, R151,
 R200, R201 = 56 k
 R30, R130, R45, R145 = 68 k
 R32, R132 = 150 k
 R33, R133, R34, R134 = 1 M
 R35, R135 = 220 k
 R38, R138 = 2k4 (E-24 series)
 R43, R143 = 270 Ω
 R44, R144 = 330 Ω
 R46, R146 = 270 k
 R47, R147 = 22 k
 R48, R148 = 4k7

R49, R149, R204 = 18 k
 R52, R152 = 1 M
 P1, P101, P2, P102, P200 = 25 k
 preset
 P3, P103 = 25 k LOG pot

Capacitors:

C24, C124 = 150 n
 C25, C125, C26, C126,
 C202 = 100 n
 C27, C127, C200, C201 = 6n8
 C28, C128 = 680 n
 C29, C129 = 680 p ker.

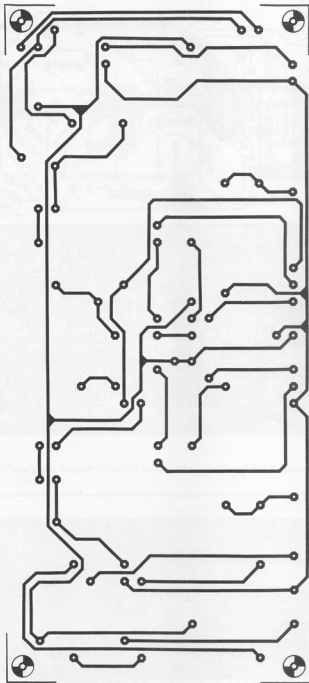

C30, C130 = 68 p ker.
 C31, C131, C34, C134 = 2µ2/25 V
 tantalum
 C32, C132 = 22 µ/25 V tantalum
 C33, C133 = 100 µ/25 V tantalum
 C35, C135, C36, C136 = 4µ7/16 V
 Semiconductors:
 D200, D201 = DUG
 T1, T101 = BC 550B
 T2, T102 = BC 550C
 T3, T103 = BF 256
 IC3, IC4, IC7, IC9,
 IC10 = MC 14066, CD 4066B,

HEF 4066B
 IC5, IC8 = RC 4136
 IC6 = 741

Miscellaneous:
 F1, F2 = BL30-HA Toko
 (Ambit)
 S1, S3, S4 = double pole toggle
 switch
 S2 = single pole switch

input connected to the main board. With a temporary link between B3 and B6, switch S1 to RECORD and S3 to TEST, the LED's should light. If this is satisfactory (turning P200 helps), both the peak meter and calibration oscillator will be O.K. The link between B3 and B6 may now be removed.

Finally, the High Com modules are left to be dealt with. With the mains supply disconnected the two modules can be fitted with their component side facing the main board. Before fitting the top panel of the case, the complete unit must be calibrated.

Calibration

This is a simple matter and does not even require the use of a meter. The power is switched on and S1 is set to RECORD, S2 and S4 to High Com and S3 to TEST. All the potentiometers and presets are set to the centre position. The LED's of the peak meter should now indicate something (if necessary, adjust the sensitivity of the meter with P1 and P'1 on the peak meter board).

The preset P200 of the calibration oscillator must now be set so that the meter gives a clear indication. Switch the High Com off with S4 and check for any alteration in the meter reading. By careful adjustment of P200 in both positions of S4, a setting should be arrived at where the meter reading remains the same for both positions of the switch. Once this setting has been achieved, the meter reading can be set to zero dB with the preset potentiometers P1 and P'1 on the peak meter board.

For the idealist, the calibration may be made more accurate by connecting a millivoltmeter to pin B6 (careful, AC here) and then switching S4 to and fro. The meter will then give a clear indication of the difference in readings between when the High Com is switched on and off.

At last the moment has arrived for the recorder to be connected to allow a test recording to be made. The switches will be in the following positions: S1 to RECORD, S2 to High Com, S3 to TEST and S4 to High Com. The relevant connecting cables between the tape recorder and the noise reduction unit are fitted. The recorder is switched to record and its recording levels are adjusted to give a reading of 0 dB on the record level meters. From now on, the recording controls of the tape/cassette deck should not be moved at all. The potentiometers on the noise reduction unit will be used for any recording level adjustments that are required.

Now a test tone can be recorded on tape, two minutes should be long enough. The noise reduction unit is then switched to playback (S1 to PLAY, S3 off) and the recorded test tone played back. Using the preset P1 on the main board (separately for each channel) the reading of the peak meter must again be set to 0 dB. The potentiometer P2

Parts list for the peak meter

Resistors:

R1, R1' = 1k5 2%
 R2, R2', R4, R4' = 470 k
 R3, R3' = 220 k
 R5, R5' = 1 k
 R6, R6' = 100 Ω
 R7, R7' = 15 k
 R8, R8' = 12 k
 R9, R9' = 1k8
 R10, R10' = 10 k
 R11, R11' = 1k2
 R12, R12' = 1k5
 R13, R13' = 120 Ω
 P1, P1' = 250 k preset

Capacitors:

C1, C1' = 10 μ /16 V
 C2, C2' = 4 μ /16 V
 C3, C3' = 27 pf

Semiconductors:

D1 ... D5, D1' ... D5' = 1N4148
 IC1 = LM 324

Parts list for the LED display

Resistors:

R1 = 1k5
 R4, R4' = 39 k

Capacitors:

C1 = 10 μ /35 V tantalum

Semiconductors:

D1 ... D9, D1' ... D9' =
 green LED
 D10 ... D12, D10' ... D12' =
 red LED
 D13, D13' = 1N4148
 D14 = zener diode 5V6/400 mW
 IC1, IC2 = UAA 180

12

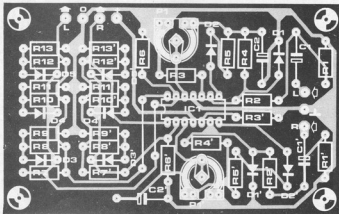
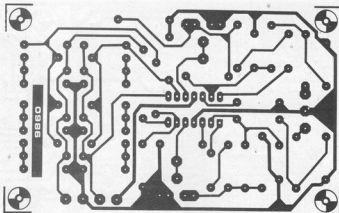

Figure 12. The printed circuit board for section A of the circuit diagram of the peak meter in figure 8.

13

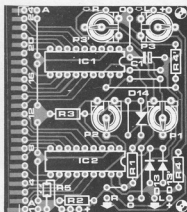
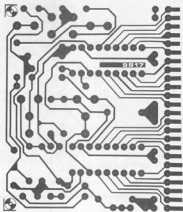
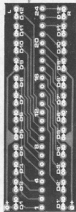
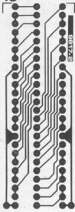

Figure 13. The printed circuit board for the display section (B) of the peak meter.

enables the output level to be adjusted to suit the input sensitivity of the amplifier in use.

And that is it, the unit is calibrated! The lid can finally be fitted on the case.

A 'normal' recording can be made and listened to. Again, don't forget to use the controls of the noise reduction unit for any level adjustments and not those of the record deck itself otherwise the

calibration procedure will have to be repeated. Make a test tone recording ... etc.

If a second tape/cassette deck is to be used, the recording level controls of this deck will have to be adjusted in the same manner with the aid of the calibration oscillator. The test tone is again recorded and P1 on the main board is calibrated during playback.

The noise reduction system in use.

Once calibration has been completed, the unit is very simple to use. The various switches operate as follows:

- S1: RECORD/PLAY.
- S2: High Com DNR switch. When DNR is selected, Dolby cassettes or tapes can be played back.
- S3: TEST. Always switched off during normal use.

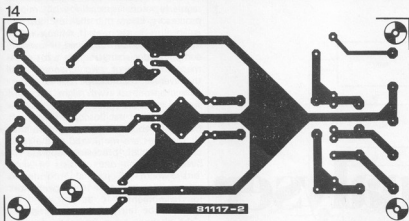

Part list for the power supply

Resistor:

R50 = 1k5/0,5 W

Capacitors:

C34, C35, C38, C39 = 100 n

C36 = 2200 μ /25 VC37 = 1000 μ /25 VC40, C41 = 4 μ /16 VC42 = 4 μ /25 V

Semiconductors:

D1 ... D4 = B1 = 1N4004

D5 = LED

IC11 = 7815

IC12 = 7808

IC13 = 7908

Miscellaneous:

Tr1 = 2 x 15 V/0,4 A transformer

F1 = 100 mA slow blow fuse

F2 = 350 mA fuse with holder

F3 = 100 mA fuse with p.c.b. mounting holder

S5 = double pole mains switch

heat sink for IC11

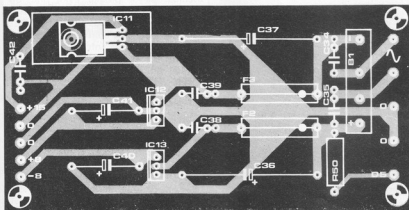

Figure 14. The printed circuit board for the power supply in figure 9. A heat sink is required for IC11.

15

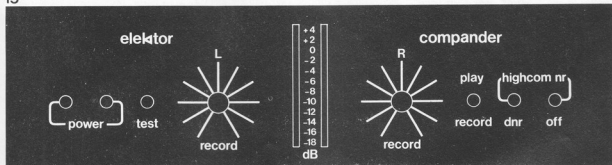

Figure 15. The front panel design for the Elektor High Com system. It is not shown in full size.

S4: High Com on/off switch. In the off position for playing 'standard' recordings (also required during calibration).

S5: Mains on/off switch. Should be in the 'on' position for optimum results.

The recording controls set the levels during recording with the aid of the built in peak meter. Only S1 has to be switched for playback.

The High Com modules

To allow the High Com system to become a viable project for our readers, the Elektor editorial staff have reached an agreement with Telefunken. The High Com system will be available only from Elektor in the form of completed and calibrated modules. All components, IC's, precision resistors and capacitors, inside the broken line in figures 6 and 7 are included. The main board together

with two modules and a self adhesive front panel will be available through the Elektor print service (EPS). Additional items required are the components for the main board and the necessary hardware. The peak meter and power supply printed circuit boards and their corresponding components must of course also be added for the High Com noise reduction system to be complete.

logic analyser

indispensable aid to digital fault finding

The analysis and comparison of digital signals is not an easy task without the aid of an expensive item of test equipment, namely a logic analyser. Unfortunately, these are invariably priced well beyond the reach of the average enthusiast with the result that fault finding, especially on computer systems, can result in a succession of inspired guesses. All is not lost however, since an ordinary oscilloscope can be coupled with the project featured in this article to produce a reasonable logic analyser.

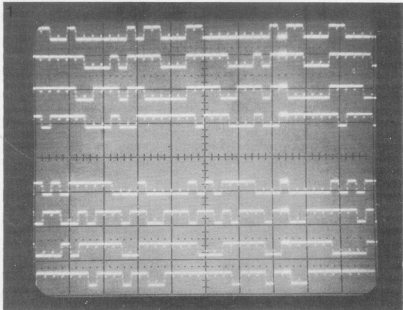

Photograph 1. An enlarged view of the data stored in RAM. The small spots on the lines are the indication of the logic level at that point.

Readers who work with digital circuits regularly, and especially with microprocessors, know that their oscilloscope is absolutely essential if reliable information is to be obtained. However, complicated circuits require a lot more than the one or two channels that the average oscilloscope has to offer. A microprocessor with eight data and sixteen address lines would need a whole bank of oscilloscopes since fault tracing in this area would require that all the lines are monitored at the same time. After all, processors operate on bytes and each one consists of eight 'bits' worth of parallel information (disregarding the new 16 bit processors for the moment).

It would be fairly simple to design an eight channel trace 'switcher' for the oscilloscope to provide eight lines on the screen simultaneously, but this would be rather pointless. Pointless because, with data continually changing at high speed the information is lost within microseconds. Thus, a memory is required where the series of digital signals can be stored before they are read out on the scope.

We also have to know which information the computer is to record at the data inputs. If, for instance, not more than twenty bytes can be stored in memory, whereas the entire program consists of over a thousand, tracing the bytes in question will be like looking for a needle in a haystack, unless there is some sort of device to help us. Test equipment manufacturers realised this long before now and came up with the logic analyser. This instrument is a combination of an oscilloscope and a digital test and memory circuit. Unfortunately, it can cost as much as £2000, well beyond the reach of most of us.

Elektor's design team felt it was time something was done to remedy the situation. Their logic analyser is a trace-switching circuit that can be connected to an ordinary oscilloscope. The Elektor version is by no means simple and the components can total up to quite a few pounds, but this is still cheap, considering the quality and potential offered.

Since the circuit diagram is rather complicated, the discussion of the practical design, its possibilities and operation will be left until a following issue and this article will concentrate upon the principle it is based on.

To start with the simple block diagram in figure 1 meets the requirements which have been dealt with so far.

Firstly, there has to be a memory to store a certain amount of eight bit parallel information, a few hundred bytes, for instance. Next the circuit has to be informed when to start reading in and this is carried out as follows. The memory stores data continuously. An eight bit word can be preset in the trigger unit. As soon as this word is recognised in the input signal, the trigger unit will generate a pulse. This activates a counter which will produce

a 'stop' signal after a certain period. When this occurs the reading-in stops and the data stored in memory can now be shown on the screen of an oscilloscope. This requires a control device to process the digital signals so that all the bytes appear on the screen in a clearly visible manner.

Reading the display is made easier with a cursor. This moves across the screen and will always indicate the eight bits belonging to one byte at a time in order to avoid any reading errors.

It will be obvious that the block diagram in figure 1 is a very much simplified version of the original. A great deal more is involved in actual fact, as the full block diagram of the logic analyser will later show.

How does it work?

In order to discuss the basic principles of the logic analyser in greater detail a more elaborate block diagram is given in figure 2.

Initially the two flipflops FF1 and FF2 are reset so that their Q outputs are at logic zero. A clock oscillator combined with a presettable divider generates the clock pulses for an eight bit counter A, the outputs of which provide the address code for a 256 x 8 RAM. The digital signals that are to be sampled, D0...D7 are written into memory at the clock frequency by means of an 8 bit latch.

After the 255th pulse, the counter is reset, starts to count from scratch again, and the memory once more starts to fill with incoming data. When a trigger pulse is generated, FF1 changes state causing counter B to start counting. The initial state of this counter can be preset with the 'trigger mode' switch. In the 'post trigger' position, the initial state of counter B will be zero. In the 'centre trigger' and 'pre trigger' positions it will be 126 and 255 respectively. The position of this switch will determine whether the final contents of the RAM will consist of data stored after, before and after, or before the trigger pulse was generated.

Depending on the initial setting of counter B, a certain number of clock pulses will be required to 'fill' it and generate a carry pulse. The carry out from the counter at that point will set FF2 thereby preventing any further new data from being read into the memory.

For example, when the trigger switch is in the 'post trigger' position, the write operation of incoming data into the memory will continue for 256 clock cycles before the write cycle is halted. In other words, the 255 bytes of data to enter after the trigger pulse is generated will be stored in the memory. In the 'centre trigger' position, 126 bytes before the trigger pulse and 129 after it will be stored, and in the 'pre trigger' position the 255 bytes before the trigger pulse will be stored. This facility is of course very useful and well worth the few components it requires.

1

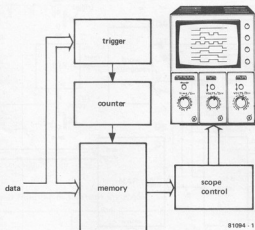

Figure 1. A very simple block diagram of the logic analyser showing the relationship of the memory, triggering, clock and oscilloscope control.

It may be as well to make a small digression and see where the trigger pulse originates from. There are in fact three methods which can be used to produce it. The first, and probably simplest method is by means of an external trigger signal. Perhaps some point in the circuit under test can be used to furnish a pulse at the correct point in time that it is required.

Secondly a trigger pulse can be derived from incoming data which as expected proves to be somewhat more complicated. The final possibility is a combination of both of the foregoing choices. For the last two options a 'word recogniser' will be required. This, as its name suggests, is a circuit that can recognise a (preset) ten bit word when (or if in some cases) it occurs in the incoming data. Since all the input data is entered into the eight bit latch initially, it is a fairly simple matter to generate a trigger pulse when the contents of the latch equals the preset word in the word recogniser.

Back to the memory input. Now the contents of the RAM have to be read out and displayed on the oscilloscope in a legible manner.

When FF2 was set it simultaneously caused switch S2 to be activated, as a result of which the entire system was switched from the preset clock frequency to a fixed scan frequency. For this the monostable multivibrator MMV will be pulsed on every carry out signal generated by counter B. This ensures that the clock oscillator is inhibited for the time period of the MMV in order to prepare the time base of the oscilloscope for a new line trigger. Once this has passed, the contents of counter C are incremented by one and at the same time, a trigger signal is issued to the oscilloscope. A line is then displayed on the screen with a vertical position deter-

mined by the state of counter C. The outputs of this three bit counter control a D/A converter which is connected directly to the Y input of the oscilloscope.

After the trigger pulse, counter A continues counting and the data now stored in the RAM are passed to a multiplexer. Provided the contents of counter C remain unchanged, the multiplexer will pass on a single bit of each byte at a time to the LSB input of the D/A converter. In this way all the 256 bits of data in a single input line are transferred to the D/A converter and then written onto the screen. In the event of a logic one, the voltage level at the Y input of the oscilloscope will be increased slightly, whereas a logic zero cause the level to remain at a constant level depending on the contents of counter C. This therefore enables the digital information of a complete data line to appear on the screen.

Now, how is the line height determined? If the contents of counter C are '000' the voltage output level of the D/A converter will therefore be 0V and the line will be traced along the bottom edge of the screen. The multiplexer will then switch data line D7 of the RAM through to the D/A converter for the period of time that it takes for the data line to be read out.

After 256 clock pulses all the information on line D7 will have been written out and counter B will then produce a carry signal and the MMV will be triggered. At the end of its time period, the contents of counter C will be incremented by one and at the same time the oscilloscope will be triggered. The line now being written on the screen will be slightly higher up than the previous line (as the contents of counter C are now 001). As before the multiplexer

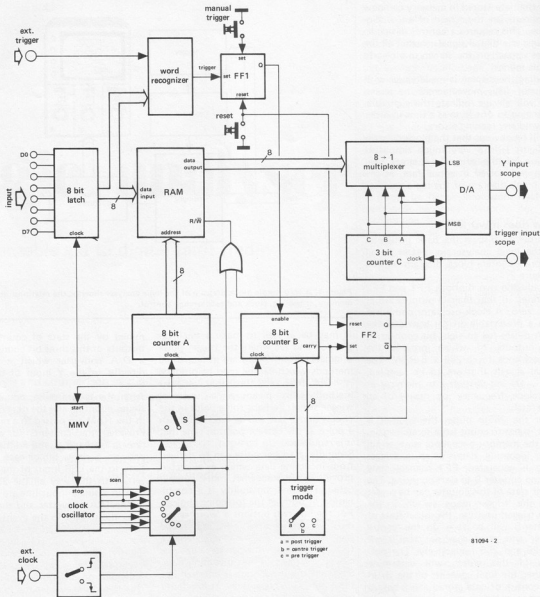

Figure 2. A far more elaborate block diagram showing the various stages in greater detail.

connects the RAM data output line to the D/A converter only this time it is data line D6. All the information on this line will now appear on the screen on the second line up.

The above operation is repeated until there are eight lines on the screen corresponding to the eight data lines of the memory. This is the whole of the memory in fact, eight lines each having 256 bits. After the entire read out cycle is completed, it starts from the beginning again and is repeated.

Figure 3 shows the voltage levels that are fed to the screen from the D/A converter. The upper signal is the trigger input and provides a pulse for each new line to be written. The Y input waveform consists of stepped voltage levels,

one step for each 256 bit data line from the memory. The lower illustration shows the corresponding oscilloscope screen, each line corresponding to a step at the Y input. In this example only a few of the data bits are shown, in actual fact each line can contain up to 256 bits across the screen.

Once the reader becomes familiar with the above operation it begins to lose its apparent complexity. However, we still have a long way to go.

So much for the logic analyser. Now let us look at the auxiliary devices which have been added for the user's benefit.

The cursor

Although the screen now contains all

the data from the RAM, eight lines with 256 bits each add up to a considerable amount of information for such a tiny scope. You don't need to be short sighted to find reading an 8 bit word from amongst that lot a strain on the eyes! And after all that's what it's all about. For this reason the logic analyser includes a useful aid which is shown in figure 4: the cursor.

The cursor acts both as a pointer and as a hexadecimal display of the byte being indicated. It consists of a pair of LED displays each connected, via a seven segment converter and buffer, to four of the eight data output lines of the RAM. The information appears on the display in hexadecimal form, the first display corresponding to data on lines D4...D7

3

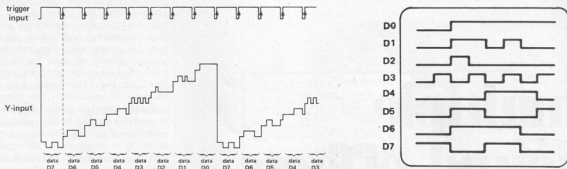

Figure 3. This shows the way in which the eight lines are derived from the contents of the RAM.

and the second to lines D0...D3. When data is being read into the RAM the displays are switched off by the Q output of FF2, which will be at logic zero. The displays will not be lit until the data is written onto the screen.

The actual pointer is made up by the cursor control, counter D and an 8 bit comparator. The position of the cursor can be controlled as required by counter D which is in turn controlled by the left/right buttons. The comparator compares the contents of counter D to that of counter A (which provides the RAM address code). When the two are equal, the comparator generates a pulse which is fed to the Z modulation input of the oscilloscope and a spot will appear on each line on the screen.

The comparator output pulse is also used to latch the eight data lines of the address concerned into the seven segment converters and the data will appear on the two displays in hexadecimal form. If the oscilloscope does not feature a Z modulation input, the cursor will appear as a 'dimple' in the data line.

After every 256 clock pulses the contents of counter A will again equal that of counter D and the comparator will generate another pulse.

The comparator output is also used to alternate the displays, a simple form of multiplexing, in order to maintain the current passing through the display at a safe level.

In this way a very useful indication is obtained. A vertical row of eight spots appear on the screen, one for each data line, and at the same time the byte indicated is shown in hexadecimal format on the display. It is a simple matter then to move the 'cursor' left or right on the screen with the two buttons until the byte in question has been found.

More to come . . .

It will be readily apparent now why a block diagram is so important to the description of circuit operation in a complicated circuit such as that in this

4

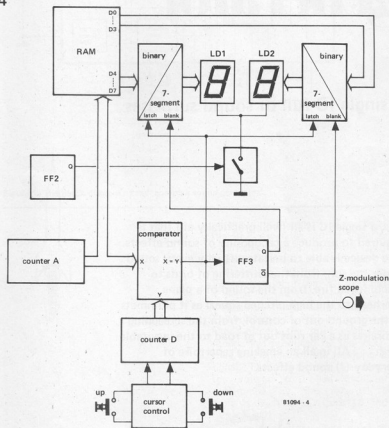

Figure 4. The block diagram of the cursor control. This includes the two LED displays for the hexadecimal readout. The RAM, FF2 and counter A sections are the same as those shown in figure 2.

logic analyser. It must be noted that, as yet, we have still only covered basic principles in this article. However, this has the advantage that the in depth details of the circuit diagram in the following article can be started with a good idea of what should be happening as we progress through the various stages.

Perhaps it would be as well to mention that this particular design is fairly extensive and as such may not be an

ideal project for beginners, but where there's a will there's a way... A logic analyser must, if it is to be of any significant use, operate at fairly high frequencies and therefore a great deal of care must be taken during its construction. Readers who are familiar with microprocessors should not experience too many problems in assembly. For those who are still a little nervous we will include some constructional tips in the next article.

multiple sound effects generator

a single IC full of sound surprises

Yes, a single IC is all (well practically all) that is required to produce a cacophony of sound effects. The device is able to imitate virtually every sound under the sun, from the twittering of birds to machinegun fire, from the sound of a plane overhead to the high pitched squeal as it plummets to the ground out of control, from the screeching of brakes as a car runs out of road to the inevitable crash . . . All in all an amazing repertoire of everyday (?) sound effects.

A great many letters have been received in response to the various sound effects generators that have been published in Elektor over the years, which shows that such circuits are still very popular. However strange or frivolous the sound may be, people always seem to be able to find plenty of uses for it. Sound freaks will be delighted to know, therefore, that Texas Instruments have developed an IC specifically for them, the 'complex sound generator' SN 76477N.

It comes in a 28 pin DIL package and contains all the ingredients required to serve up a whole menu of interesting and refreshing sound effects. A resistor here, a capacitor there and a couple of transistors constitute the only other components required. The latter simply amplify the output signals to a level sufficient to drive the loudspeaker.

This IC is by no means new. In fact it was first described in the September 1978 edition of Elektor under the heading Applikator. We were then mainly interested in the theoretical and technical aspects of the device. Now, however, we shall concern ourselves more with the practical side of things.

The IC was found to produce a total of seven basic (and different) sound effects. There are, therefore, a minimum of seven different circuits involved, but as they all have certain things in common, it was possible to design a single printed circuit board on which they can all be incorporated. Each individual effect requires a slight modification to the combination of components used.

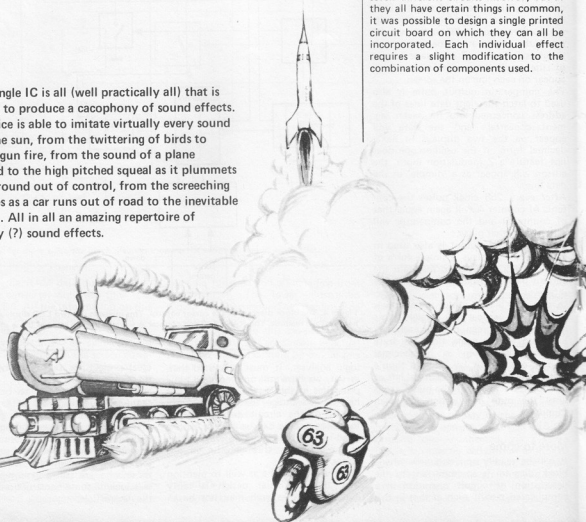

The IC

Since the 'internals' of the IC have already been discussed in detail in the September 1978 issue, it will suffice to give a brief survey of the most important features. Readers who wish to delve a little deeper into the technology involved are referred to the article mentioned above. It includes all the various formulae and tables that are of interest.

The block diagram of the 'complex sound generator' IC is given in figure 1, together with a few external components that are required. A closer examination reveals that there are three fundamental signals produced. These signals are obtained from: the Super Low Frequency oscillator (SLF), the Voltage Controlled Oscillator (VCO) and the noise generator.

The SLF section contains an oscillator which covers the super low frequency range between 0.1 Hz to 30 Hz. Under special circumstances it can also be used at higher frequencies. The frequency of oscillation is determined by the values of Resistor R_S and capacitor C_S (connected to pins 20 and 21 respectively). Also shown is the fact that the SLF oscillator provides two output signals. The first is a squarewave signal which is processed by the mixer stage and the second is a triangular waveform which can be used to control the VCO by way of the external VCO/SLF select section.

The VCO block consists of an oscillator whose frequency is totally dependent

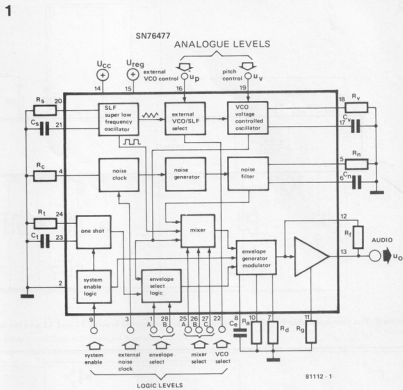
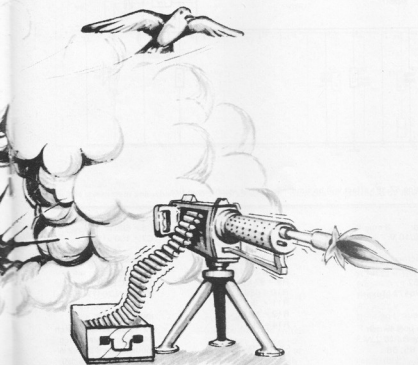

Figure 1. The block diagram of the 'complex sound generator'.

on the input voltage. This can be either the SLF oscillator output signal or an external signal applied to the U_D input at pin 16 of the IC. Which one it is to be is determined by the logic level at the VCO select input (pin 22). In addition, a signal at the U_D input enables the VCO output to be frequency modulated. The voltage at U_V (pin 19), on the other hand, affects the duty cycle of the squarewave produced by the VCO and thus the timbre of the resulting audio signal. The free-running frequency of the voltage controlled oscillator is determined by the external components R_V and C_V (pins 18 and 17 respectively).

The pseudo-random white noise generator is triggered by the noise clock whose internal current level is determined by the value of R_C (pin 4). The resultant signal is then passed through the noise filter. The turnover point of this low pass filter can be altered by selecting different values for the components R_N and C_N (pins 5 and 6 respectively). Alternatively, the nature of the noise signal can be changed by applying an external clock signal to the input at pin 3.

So far so good. Now for the remaining sections. A logic 'one' level at pin 9 causes the system enable logic to suppress the output signal from pin 13 of the IC... When this same input is



2

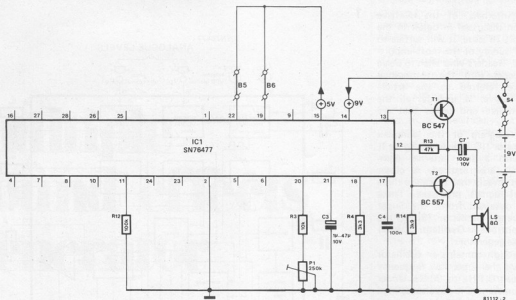

Figure 2. The siren/spaceship circuit. The amplifier stage constructed around T1 and T2 and the on/off switch S4 are used in each different circuit.

3

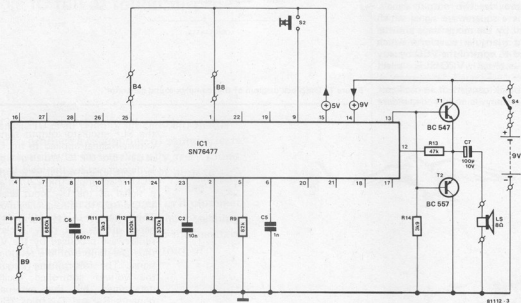

Figure 3. The gun shot circuit. By repeatedly depressing S2, the effect will be similar to that of machinegun fire.

Parts lists

Figure 2.

resistors:

R3 = 10 k
R4 = 3k3
R12 = 100 k
R13 = 47 k
R14 = 3k9
P1 = 250 k preset

capacitors:

C3 = 1 μ ... 47 μ /10 V

C4 = 100 n
C7 = 100 μ /10 V

semiconductors:

T1 = BC 547
T2 = BC 557
IC1 = SN 76477 (Texas)

miscellaneous:

S4 = single pole switch
loudspeaker 8 Ω /0.2 W
wire links: B5, B6

Figure 3.

resistors:

R2 = 330 k
R8, R13 = 47 k
R9 = 82 k
R10 = 680 k
R11 = 3k3
R12 = 100 k
R14 = 3k9

capacitors:

C2 = 10 n
C5 = 1 n

C6 = 680 n
C7 = 100 μ /10 V

semiconductors:

T1 = BC 547
T2 = BC 557
IC1 = SN 76477 (Texas)

miscellaneous:

S2 = pushbutton switch
S4 = single pole switch
loudspeaker 8 Ω /0.2 W
wire links: B4, B5, B9

4

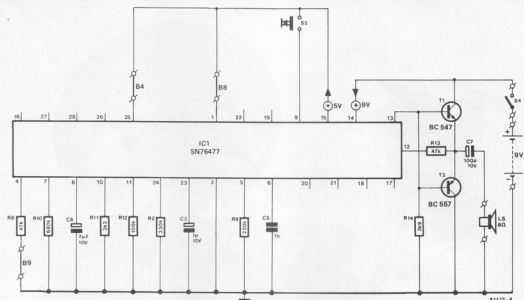

Figure 4. The explosion circuit. Basically, this is little more than a drawn out gun shot.

5

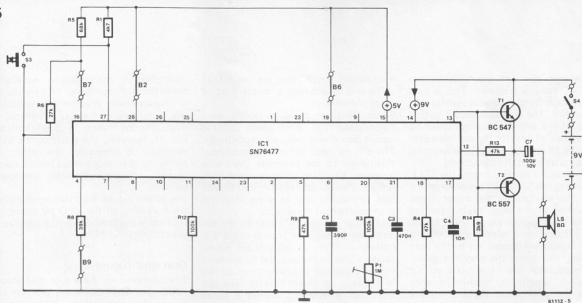

Figure 5. The steam train and whistle circuit. The speed of the train can be controlled by means of P1 while S3 activates the whistle.

Figure 4.

resistors:

R2 = 330 k
R8, R13 = 47 k
R9 = 220 k
R10 = 680 k
R11 = 3k3
R12 = 100 k
R14 = 3k9

capacitors:

C2 = 1 μ /10 V
C5 = 1 n

C6 = 2 μ 2/10 V
C7 = 100 μ /10 V

semiconductors:

T1 = BC 547
T2 = BC 557
IC1 = SN 76477 (Texas)

miscellaneous:

S2 = single pole switch
S4 = single pole pushbutton switch
loudspeaker 8 Ω /0.2 W
wire links: B4, B5, B9

Figure 5.

resistors:

R1 = 4k7
R3, R12 = 100 k
R4, R9, R13 = 47 k
R5 = 68 k
R6 = 27 k
R8 = 39 k
R14 = 3k9
P1 = 1 M preset

capacitors:

C3 = 470 n

C4 = 10 n
C5 = 390 p
C7 = 100 μ /10 V

semiconductors:

T1 = BC 547
T2 = BC 557
IC1 = SN 76477 (Texas)

miscellaneous:

S3 = pushbutton switch
loudspeaker 8 Ω /0.2 W
S4 = single pole pushbutton switch
wire links: B2, B6, B7, B9

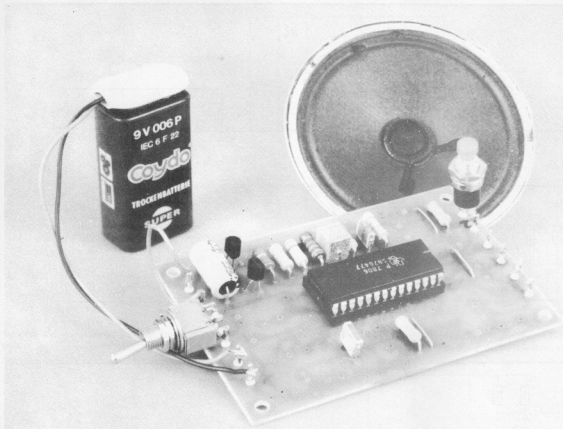

taken low, the one shot (monostable multivibrator) is triggered. This is used to generate 'single' sounds such as that of gunfire. The duration of the output pulse of the one shot is determined by the values of resistor R_1 and capacitor C_1 (pins 24 and 23) and can be anything up to a maximum of ten seconds.

The output signals from the SLF oscillator, the VCO and the noise generator are all fed to the mixer stage. According to the logic levels presented to the mixer select inputs (pins 25, 26 and 27) one, or a combination of, the three signals are passed on to the next section, this being the envelope generator/modulator. Here the mixer output signal is amplitude modulated with either the VCO output signal or the one shot depending on the logic level applied to the envelope select inputs (pins 1 and 28). If the VCO signal is selected, both amplitude and frequency modulation are possible.

Finally, we come to the output amplifier. The gain of this stage is determined by the values of resistors R_7 and R_8 (pins 12/13 and 11 respectively). In the given circuit examples this amplifier is immediately followed by a symmetrical output stage made up from a complementary pair of transistors. These in turn drive the loudspeaker.

The sound effects

Clearly, the SN 76477N IC is extremely versatile. The signals that can be generated by component combinations and

modulation possibilities are more than sufficient to produce a whole host of aural phenomena.

Seven different basic variations were constructed and a universal printed circuit board was designed accordingly. There is no need for readers to restrict themselves to the examples given here however. Feel free to experiment with different values of resistors and capacitors to modify and in some instances even improve on the effects.

One major advantage is that all the circuits can be supplied from a single 9 V battery or from an unregulated power supply. This is because the IC contains its own internal regulator (not shown in figure 1, so you'll have to take our word for it!!) which derives a stable 5 V from the original input voltage (pin 14 : 9 V in, pin 15 : 5 V out). Obviously, the current consumption will depend on the volume of the output signal, but should not exceed more than about 20 mA.

The various circuits will now be reviewed briefly, regarding the IC itself more or less as a 'black box', so as not to have to go into too much detail for each variation.

Siren (figure 2)

This is a nice straightforward circuit for a start. Only three resistors and two capacitors are involved, in addition to the loudspeaker amplifier which is the same for all the examples and is connected to pins 11...13. The VCO is

controlled by the triangular waveform from the SLF oscillator. This results in a characteristic siren effect provided the frequency of the SLF oscillator is kept low (by means of potentiometer P1). If, however, the pitch of the SLF oscillator is increased, the effect is similar to that of a science fiction space rocket 'zipping' through unknown galaxies.

The effect can be modified by changing the frequency of the VCO by means of R4 and C4 and that of the SLF oscillator with C3, R3 and P1.

Gun shot (figure 3)

The sections we have just mentioned (VCO and SLF oscillator) are not required for this effect. White noise, together with a sharp attack, is what is needed for the gun shot. When switch S2 is pressed the one shot is activated via a negative going pulse on pin 9. Low frequency noise is fed to the output via the envelope generator/modulator. The attack and decay time constants are determined by the components R10, R11 and C6. The sound of the gun shot is made more realistic as the noise generator actually produces a sound similar to that of thunder. By repeatedly depressing S2 the sound of machinegun fire can be simulated.

Explosion (figure 4)

Basically the circuit is identical to that of the gun shot, only this time the noise

6

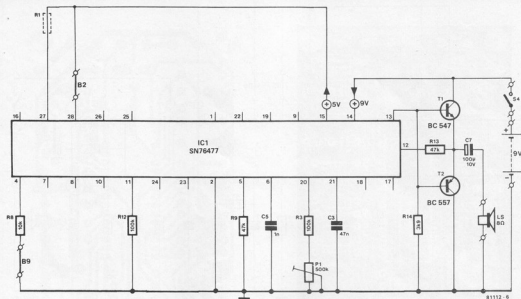

Figure 6. The aeroplane circuit. Sounds rather like the 'runaway train'!

7

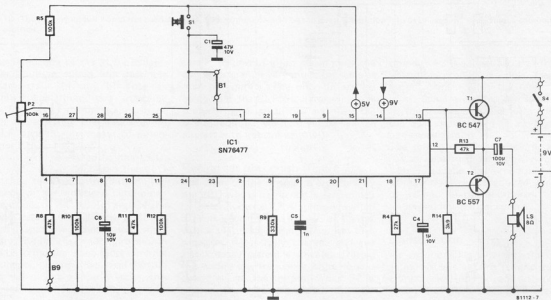

Figure 7. The racing car and crash circuit. The sound of the car engine is controlled by means of P2. The car will 'crash' when S1 is depressed.

Figure 6

resistors:

R3, R12 = 100 k
 R8 = 10 k
 R9, R13 = 47 k
 R14 = 3k9
 P1 = 500 k preset

capacitors:

C3 = 47 n
 C5 = 1 n
 C7 = 100 μ /10 V

semiconductors:

T1 = BC 547
 T2 = BC 557
 IC1 = SN 76477 (Texas)

miscellaneous:

S4 = single pole switch
 loudspeaker 8 Ω /0.2 W
 wire links: B2, B9, R1

Figure 7.

resistors:

R4 = 27 k
 R5, R10, R12 = 100 k
 R8, R11, R13 = 47 k
 R9 = 330 k
 R14 = 3k9
 P2 = 100 k preset

capacitors:

C1 = 47 μ /10 V
 C4 = 1 μ /10 V
 C5 = 1 n

C6 = 10 μ /10 VC7 = 100 μ /10 V

semiconductors:

T1 = BC 547
 T2 = BC 557
 IC1 = SN 76477 (Texas)

miscellaneous:

S1 = pushbutton switch
 S4 = single pole switch
 loudspeaker 8 Ω /0.2 W
 wire links: B1, B9

8

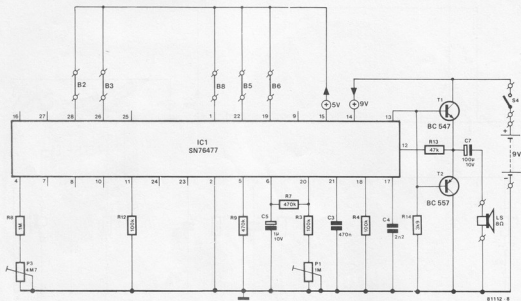

Figure 8. The dawn chorus circuit. By carefully adjusting P3 the 'bird song' can be tuned in nicely!

9

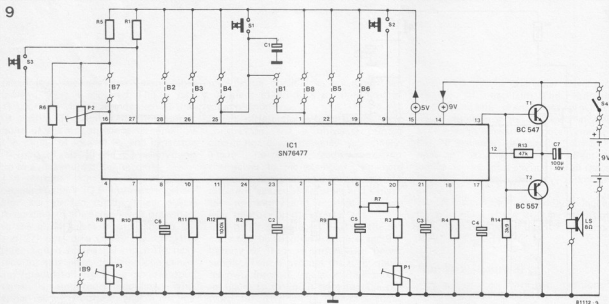

Figure 9. A general survey of all the components that can be fitted onto the print circuit board.

Figure 8.

resistors:
 R3, R4, R12 = 100 k
 R7, R9 = 470 k
 R8 = 1 M
 R13 = 47 k
 R14 = 3k9
 P1 = 1 M preset
 P3 = 4M7 preset

capacitors:
 C3 = 470 n

C4 = 2n2
 C5 = 100 μ /10 V
 C7 = 100 μ /10 V

semiconductors:
 T1 = BC 547
 T2 = BC 557
 IC1 = SN 76477 (Texas)

miscellaneous:
 S4 = single pole switch
 loudspeaker 8 Ω /0.2 W
 wire links: B2, B3, B5, B6, B8

is a little lower in frequency and somewhat drawn out due to the longer time constants that are used for the attack, decay and one shot.

Steam train and whistle (figure 5)

Since the sound produced by a steam train consists mainly of white noise, this effect will present no problems to our IC. As soon as the on/off switch S4 is closed, an intermittent white noise signal will appear at the output. The rhythm of the signal will be determined

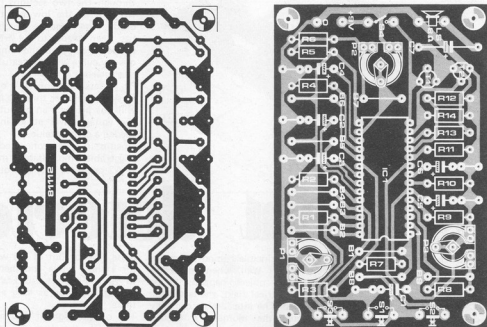

Figure 10. The printed circuit board has been designed to accommodate all of the circuits described. In each case any superfluous components can be omitted.

by the frequency of the SLF oscillator and the resulting sound will resemble a steam train (if any of you can remember what they used to sound like!) The speed of the train can be altered by adjusting the frequency of the SLF oscillator by means of potentiometer P1.

The whistle is generated by the VCO. When switch S3 is depressed the VCO is switched through to the output. The frequency of the whistle is determined by the values of R4, R5, R6 and C4. To be honest, the whistle sounds a lot less authentic than the steam train. Unfortunately, the only way to improve on it would be to include many more external components, which we feel would defeat the object of the exercise, this being to keep the circuit as simple as possible.

If this particular sound effect is to be used for a model railway, the frequency of the SLF oscillator should be directly related to the speed of the locomotive. This can be done by replacing potentiometer P1 with a light dependant resistor (LDR) which is optically coupled to a 6 V/50 mA lamp that is connected across the rails (with a 1 k preset potentiometer wired in series). When the voltage on the rails (speed) is increased, the lamp will burn brighter, so that the resistance of the LDR will drop and the frequency of the SLF oscillator will therefore rise (QED).

Aeroplane (figure 6)

Since an aeroplane makes a sound very

similar to that of a fast steam train, the circuit diagram is very much the same as that of figure 5. The only differences being that the SLF oscillator will have a much higher frequency and the VCO is not required, we have yet to hear an aircraft with a steam whistle!!

Racing car plus crash (figure 7)

The roar of the engine is provided by the VCO whose frequency is determined by potentiometer P2. Depressing switch S1 will interrupt the motion of the car with a shattering 'crash' effect. For this, capacitor C1 is fully charged and the attack/decay system is activated. During this period low frequency white noise is passed on to the output. When S1 is released the car (or its ghost!) will start up once more after the short delay required for C1 to discharge.

Dawn chorus (figure 8)

Again, this mainly involves the VCO and the SLF oscillator. The VCO is controlled by the negative going edge of the triangular waveform provided by the SLF oscillator. As a result, the signal produced will slowly drop in frequency. Nothing happens during the positive period of the triangle, so that there is a short break. The frequency of the VCO is determined by the setting of potentiometer P1.

Since the effect thus obtained is rather monotonous, the noise generator has been called in to help and R7...R9, P3 and C5 have been included. Poten-

tiometer P3 is adjusted so that the noise generator produces a low frequency output signal. Then the random sawtooth signal generated across C5 is fed to the frequency determining input of the SLF oscillator. This livens up the birds considerably.

The setting of P3 is quite critical, as it has to be turned very slowly and carefully until the dawn chorus becomes sufficiently lively. If required, the values of R8 and P3 can be altered to give a somewhat less critical control.

Construction

As mentioned previously, the various sound effects circuits require very few components (one IC and a handful of external components). Once these have been mounted on the printed circuit board (see figure 10), all that remains is to connect up a small loudspeaker and a battery — then the fun can begin!

The printed circuit board can be used for all of the circuits described in this article (and doubtless a few more besides). In each case it is simply fitted with the components indicated in the parts list. Any parts marked on the component overlay, but not mentioned in the particular parts list can be omitted. For those of you who would like to do a little experimenting, figure 9 provides a general survey of all the components for which there is room on the board. This makes it a lot easier to 'translate' the circuit diagram in relation to the board and vice versa.

Proximity

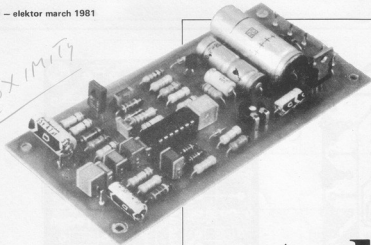

movement detector

In spite of the fact that an electronic movement detector is used in many department stores and office blocks nowadays, a great number of people still think it something of a mystery when the doors slide open automatically as they approach the exit with a loaded trolley. In vain they look for the 'thing' that noticed their presence. In some cases it is a shaft of light catching passing legs, but usually the method of detection will be invisible and therefore all the more mysterious. The system described here not only opens doors but also switches lights on and off and can in fact even be used for a game, the purpose of which is to sneak out an object from a guarded room (good practice for burglars!)

What is the principle behind the movement detector? Well, when an electrically charged object happens to be inside an electrical field, the latter will be disturbed. The interference can only be detected the moment it occurs, in other words, not once the situation has returned to normal. Similarly, a moving electrical field will affect a conductor that is present. Generally speaking, human beings are surrounded by a weak electrical field created, mainly, by friction. Every physical movement of a conductor causes charge carriers inside it to be displaced and this can be detected.

How the circuit works

Together with the FET T1, resistors R1...R3, capacitors C1, C2 and C4 and the 'sensor plate', the input stage of the circuit acts as an LC tuned circuit followed by an amplifier. The input circuit, consisting of R1, R2 and C1, functions mainly as the inductor. In parallel with the capacitor formed by the sensor plate, the 'inductor' produces a parallel tuned circuit with a centre frequency just below the mains frequency. Any change in the surrounding electrical field will affect the coil, causing the tuned circuit to oscillate.

Before it reaches the amplifier the output of the tuned circuit first has to pass through the two sections (R4, C5 and R5, C6) of the low-pass filter. In addition, the negative feedback of A1 has been made to be frequency dependent, so that the amplifier's frequency curve will also feature a low-pass characteristic.

P1 presets the sensitivity of the circuit in such a manner that the amplifier A2 will not produce an output signal until the voltage level at its input has exceeded a certain value.

Opamp A3 is connected as a retriggerable monostable multivibrator. If A2 produces only one output trigger

pulse, the output of A3 will be 'high' for a short while and then drop back to zero. Further pulses will hold the output high for as long as they continue.

The output high of A3 reverse biases diode D5 therefore the noninverting input of opamp A4 will also become logic one. This opamp then generates a square wave output with a frequency in the 400 Hz range, which, via transistor T2, will be heard from the loudspeaker. The volume can be regulated with P2 as required. To prevent the generator from oscillating continually opamp A4 is switched off by diodes D4 and D5 whenever the output of A3 becomes low again.

In addition to the audible signal, the monostable multivibrator A3 provides the base drive current for transistor T3 by way of the voltage divider R19 and R22. The collector current then operates the relay Re which may be used for various switching purposes. When the relay is released, diode D2 protects T3 by eliminating any induced voltage. Diode D3 makes sure T3's collector will remain higher than the emitter voltage by more than 1 V.

It is important that the earth of the circuit is connected to that of mains, if it is to work well.

Parts List.

Resistors:

R1 = 12 M
R2 = 1 M
R3, R15 = 10 k
R4 = 15 k
R5, R6 = 47 k
R7, R21 = 470 Ω
R8 = 33 k
R9, R10 = 4k7
R11, R16 = 470 k
R12, R13, R14 = 100 k
R17, R18 = 22 k
R19 = 2k7
R20 = 1k2
R22 = 1 k
P1 = 220 k preset
P2 = 100 Ω/1 W, linear

Capacitors:

C1 = 560 n
C2, C7 = 330 n
C3 = 10 μ/16 V
C4 = 10 n
C5 = 390 n
C6, C12 = 100 n
C8 = 47 μ/10 V
C9 = 220 μ/16 V
C10 = 1 μ
C11 = 10 μ/10 V
C13 = 3n3
C14 = 47 μ/25 V
C15 = 1000 μ/25 V

Semiconductors:

IC1 = LM 324
IC2 = 7812
T1 = BF 256C
T2 = BD 139
T3 = BC 547B
D1, D2, D3, D4 = 1N4148
D5 = AA 119
D6, D7, D8, D9 = 1N4001

Miscellaneous:

Tr = 12 V/0.5 A transformer
Re = 12 V relay
LS = 8 Ω loudspeaker

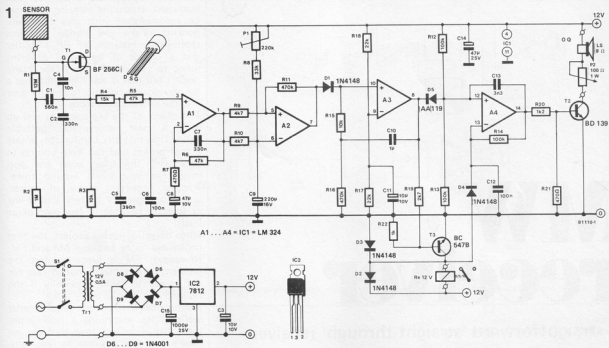

2

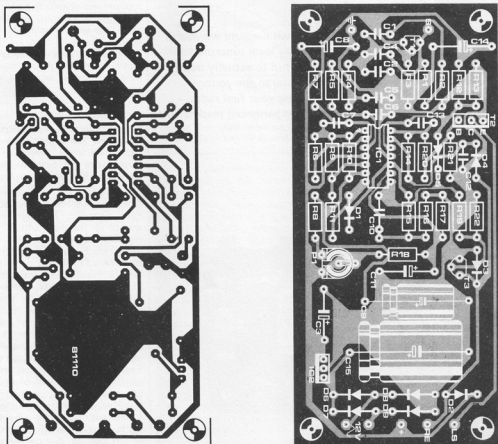

MW receiver

a straightforward 'straight-through' receiver

Why should there be a need to construct your own medium waveband receiver? Surely it is far cheaper to buy one at the local supermarket? This may well indeed be true, but it is far more fun to actually build one yourself. After all, many of our readers belong to the younger generation and there is nothing quite like building your first radio — and getting it to work! — as many of our more experienced readers will testify.

Amateur constructors often feel like magicians. It is quite amazing what can be accomplished with very few components. Take the design for this receiver for instance; an RF amplifier and a couple of transistors to bring music to your ears! In any case, many readers felt that it was high time that a simple receiver circuit found its way into the EPS list once more.

The object of the exercise is to end up with a neat, economical portable radio. One that fits comfortably inside a coat pocket and can keep you up to date with the latest news and pop music, as you travel around town. Another important factor, of course, is that a single 9 V battery should last as long as possible (a few months at least).

When designing such a project, the first choice has to be between AM and FM. Nowadays, FM is favourite, but the problem here is that is not so easy for the novice to build, especially if the finished unit is to be really small.

Elektor does have printed circuit boards available for something a little larger than that described here, but by no means one that requires so few components, it can be virtually put together with your eyes closed. Which is our main objective, remember.

We therefore came to the conclusion that there is nothing wrong with the medium waveband. It certainly has not run out of stations yet and what is more, the set will be much simpler (and cheaper) to build than an FM radio. It can be far smaller in size and last, but by no means least, it needs no finicky aerial. In other words, it really is a pocket radio.

Superhet or superreg?

Now that we have decided upon medium wave and the main requirements are that it be small, simple to build and conservative on batteries, we need to work out a few more design parameters.

The majority of manufactured radio receivers operate on the superheterodyne principle. However, most single waveband receivers utilise the super-regenerative principle. This is, in fact, *the* recipe for a reliable receiver if it is to have a fairly high performance and feature reasonable sensitivity in spite of its compact size. Nevertheless, if such considerations as simplicity of construction and ease of calibration are involved, the 'super' part is best omitted. This is further illustrated in figure 1. All the most common AM receiver principles are shown there.

First the 'straight-through' receiver (a). This is comprised of an adjustable LC tuned circuit, a high frequency amplifier, a detector, an audio amplifier, a detector, an audio amplifier and a loudspeaker. The RF stage could even be left out, so that the set would then be a 'sophisticated' crystal receiver. If it is to be sufficiently sensitive, however, rather a lot of RF amplification



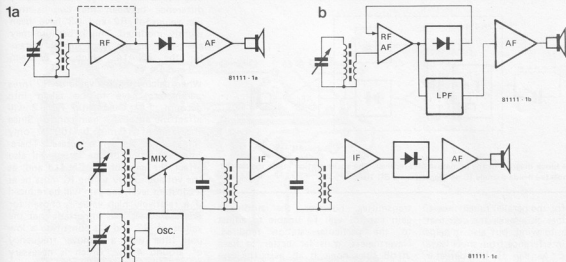

Figure 1. The three most common types of AM receiver: a straight-through receiver (a), a reflex receiver (b) and a superheterodyne receiver (c).

will be necessary. This is why the RF amplifier usually incorporates an adjustable feedback network (see dotted line) which enables the set to be adjusted to the point of oscillation (maximum sensitivity) for every station.

The reflex receiver in figure 1b also offers a reasonable degree of sensitivity. Here the RF amplifier stage is not only used in the conventional manner, but it also amplifies the audio signal. This type of receiver used to be very popular in the days when transistors were rather expensive and difficult to obtain.

Figure 1c shows that even the 'simple' superhet can be quite complicated. The aerial signal is now 'added' to that of an oscillator in the mixing stage. The oscillator produces a somewhat higher (or lower) frequency than the input signal and is varied simultaneously with the tuning capacitor. This generates a constant 'sum' or 'difference' frequency regardless of the actual frequency of the input signal. This 'intermediate' (IF) frequency is filtered at the output of the mixer and is further amplified. If necessary, the signal can be filtered and amplified several times to improve the selectivity. This is because the constant frequency of the IF signal makes the tuning of the LC circuits for each station superfluous. Obviously, the receiver will be rather complicated to set up.

Straight-through

Seeing that practically all the receivers that have been published in Elektor over the past few years were either superheterodyne or superregenerative, our design staff thought that it was time that a simple version was produced. In any event, an IC exists which will fit the bill perfectly, but more about this later. Thus, after due consideration, the recipe illustrated in figure 1a was chosen for the miniature MW receiver,

2

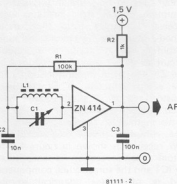

Figure 2. What could be simpler? The straight-through receiver using the ZN 414 IC.

albeit without the feedback stage. The latter, even in the version shown in figure 1b, will make any receiver a lot less portable. Also, construction becomes a critical task, the set is likely to 'whistle' and more often than not the receiver will have to be operated with both hands as the amount of feedback has to be adjusted for each individual station. If an ordinary 'straight-through' receiver can be built to incorporate enough RF amplification for feedback to become superfluous, without causing it to oscillate, it will have many practical advantages. The miniature integrated circuit that we have in mind does just this and furthermore features other useful characteristics, as will be seen later.

Compared to more usual sets, a simple single tuned circuit receiver (such as this one) will be much less selective and therefore not so sensitive. Since MW receivers, especially pocket-sized ones, are more often than not used for reception of a limited number of local radio stations, this disadvantage will not

be so noticeable. It is amply compensated by the following advantages over other types:

- it is much easier to build
- it does not require any alignment
- it does not include an oscillator, thereby avoiding stability problems
- no mixing is involved, reducing 'whistle' considerably
- its sound is of superior quality to that of the average superhet

The ZN 414

By far the easiest method of constructing a straight-through medium, waveband receiver is to use the ZN 414 integrated circuit from Ferranti which was designed specifically for this purpose.

Having only three pins, it looks more like a transistor than a 'proper' IC. Although it has been around for quite some time, it continues to provide the best solution for a receiver where a minimum number of components is required. This is clearly illustrated in the diagram in figure 2. It shows the complete MW receiver constructed around the ZN 414. All that is required is a single transistor amplifier stage to provide a first class matchbox receiver.

Certain items immediately catch the eye. First, the low supply voltage. The ZN 414 is designed to be powered from a single battery. Its supply voltage range is between 1.2 and 1.6 V and the current consumption is in order of 0.3 mA. This device could hardly be more economical.

Also remarkable is the fact that the coil (L1) consists of a single winding, instead of the usual double-wound or tapped inductor, and that the detector diode which one would usually expect is missing.

The double wound coil is superfluous as the IC features an extremely high input impedance (4 M Ω) which is only a very

3

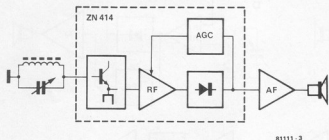

Figure 3. The block diagram of the miniature MW receiver. The entire section inside the dotted area is incorporated inside a single IC no bigger than a BC 107.

slight load for the parallel tuned circuit. Not only does this make the coil that much easier to wind, but also it helps to prevent interference from short wave transmitters. As far as the detector diode is concerned, this is already integrated in the IC in the form of a transistor detector which uses capacitor C3 as the only external component.

The block diagram of the medium waveband receiver, see figure 3, shows just what goes on inside the case of the ZN 414 (see inside the dotted area). It is comprised of a high impedance input stage (drawn here as an emitter follower), a (three stage) RF amplifier with a frequency range of 150 kHz ... 3 MHz and a gain of 72 dB, an AM detector and, finally, an automatic gain control (AGC).

Too much should not be expected from the latter, as its range is about 20 dB, just enough to smooth out any slight differences in amplitude between the various radio stations. As soon as the unit is in close proximity to a powerful

transmitter, however, the automatic gain control will be unable to adjust to the particular station required. Nevertheless, it is far better to have 20 dB than none at all, as is the case in some elementary receivers.

Circuit diagram

From the block diagram in figure 3 it can be seen how straightforward the complete pocket sized medium wave receiver is. Apart from the parallel tuned circuit, the ZN 414 and the audio amplifier, all it needs is a suitable circuit to derive the 1.3 V required by the ZN 414 from the power supply for the audio amplifier. A simple bleed resistor and zener diode would have been more than adequate, but a far better method has been employed here. The complete circuit diagram of the MW receiver is shown in figure 4. The actual receiver section is constituted by IC1 and the surrounding components and is, of course, identical to the

diagram shown in figure 2. The only difference between the two is that the values of R2 and C3 have been slightly modified. This is because they are based on the ideal supply voltage for the ZN 414, which is between 1.3 and 1.4 V.

When calculating the value of R2 three parameters have to be taken into account. First, the ratio R1/R2 will affect the automatic gain control. Since the value of R1 must be 100 k Ω , only the value of R2 can be altered. Therefore, the value of the latter will also affect the gain of the ZN 414 and, as the voltage supply to the IC must be at a constant level, the gain will be reduced if a relatively high value is chosen for R2. Moreover, it is important that the values of R2 and C3 constitute a low pass filter with a turnover frequency of around 4 kHz, which is necessary for the detector included in the IC.

The solution, therefore, is to select the best compromise value for R2 and to find an effective method of regulating the supply voltage for the ZN 414. This is why the voltage source constructed around transistor T1 has been added to the circuit. The voltage on the emitter of T1 can be adjusted between approximately 1.2 and 1.45 V by means of the preset potentiometer P2. This may not seem to be very much, but it affects the gain of the IC somewhat considerably. This is an advantage as the sensitivity of the receiver can now be adapted to specific circumstances by presetting the gain of the amplifier as required. Obviously, this will be at a maximum in isolated areas and lower in the vicinity of powerful local transmitters so that the set is not overdriven, which could

4

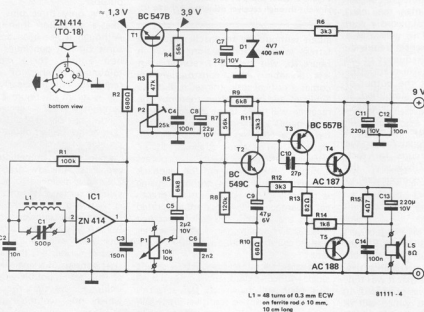

L1 = 48 turns of 0.3 mm ECV
on ferrite rod ϕ 10 mm,
10 cm long

Figure 4. The circuit diagram of the complete MW receiver featuring reasonable sensitivity, good selectivity and good quality sound.

5

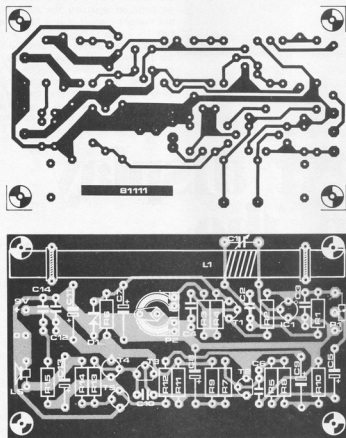

Figure 5. The printed circuit board and component overlay for the MW receiver.

cause distortion and poor selectivity. Batteries spend a very brief period of their lifespan at their rated nominal voltage and for this reason, together with the fact that the supply voltage for IC1 is critical, the voltage source T1 is not fed directly from the battery. Instead, the voltage is first regulated by a zener diode (D1) to iron out any fluctuations in the battery voltage. Since the receiver also has to be economical, the current supply to the zener diode is limited by means of a fairly large series resistor (R6). As the current consumption of the ZN 414 is very low the zener diode will operate very well, even at a low voltage than that which it is rated at (about 3.9 V in this case). So much for the receiver section. Now for the audio amplifier. Initially, it was proposed that one of the well-known amplifier ICs should be used. These, however, turned out to rapidly exhaust the small 9 V battery's current supply. Instead, it was decided to combine two pnp transistors and two npn transistors to form a discrete amplifier. Very little can be said about this, as it is constructed entirely according to the 'four transistor recipe'. It requires very little

current and there is virtually no quiescent current for the output transistors T4 and T5. Thus, when there is no input signal the entire amplifier will only consume around 2.5 mA.

Since the current requirement for the ZN 414 is also fairly modest, the receiver will only consume a total of 4 mA. A reasonable battery will therefore last a considerable time, provided the volume is not turned up to an ear-splitting level, that is. The maximum output power of the audio amplifier is in the region of 250 mW. In theory it will produce more from a 9 V battery (about 1 W maximum into 8 Ω), but the voltage gain of the audio stage is limited so that no more than 4 V_{pp} is available across the loudspeaker output even when the output signal from the ZN 414 is at a maximum (approximately 30 mV_{eff}). This maintains the current consumption at a level acceptable to the 9 V battery and also eliminates the need for heat-sinks on the two output transistors.

Construction

The printed circuit board and com-

Parts list

Resistors:

R1 = 100 k
R2 = 680 Ω
R3 = 47 k
R4, R7 = 56 k
R5, R9 = 6k8
R6, R1, R12 = 3k3
R8 = 120 k
R10 = 68 Ω
R13 = 82 Ω
R14 = 1k8
R15 = 4 Ω 7
P1 = 10 k log
P2 = 25 k preset

Capacitors:

C1 = 500 p variable capacitor
C2 = 10 n
C3 = 150 n
C4, C12, C14 = 100 n
C5 = 2 μ 2/10 V
C6 = 2n2
C7, C8 = 22 μ /10 V
C9 = 47 μ /6 V
C10 = 27 p
C11, C13 = 220 μ /10 V

Semiconductors:

T1 = BC 547B
T2 = BC 549C
T3 = BC 557B
T4 = AC 127, AC 187
T5 = AC 128, AC 188
IC1 = ZN 414
D1 = 4V7 zener diode, 250 mW or 400 mW

Miscellaneous:

LS = 8 Ω /0.2 W loudspeaker
L1 = 48 turns of 0.3 mm dia enamelled copper wire on a ferrite rod of 10 mm diameter 10 cm long

ponent overlay for the medium wave-band receiver are shown in figure 5. The only components which are not actually mounted on the board are the variable capacitor C1, potentiometer P1 and the loudspeaker. The leads connecting the capacitor to the board should, obviously, be as short as possible.

As you probably already know, the performance of a parallel tuned circuit is largely dependent on the Q of the tuning inductor. For this reason, the aerial coil, L1, will have to be wound with the utmost care and attention. It is best to use the parameters specified, that is, 48 turns of 0.3 mm diameter enamelled copper wire on a ferrite rod with a diameter of 10 mm and a length of 10 cm. The ferrite rod can be mounted onto the board by means of two short pieces of string. Holes have already been drilled in the printed circuit board for this very purpose.

It is a good idea to wind L1 around a paper or cardboard tube so that it can be moved up and down on the ferrite rod later; the permeability of ferrite and ferroxcube material tends to vary, so therefore it may be necessary to 'trim' the receiver if the stations are not at

the correct places on the waveband. Further remarks. Firstly, something that probably does not need mentioning. As the ferrite rod coil is in fact an aerial, it would be unwise to mount the completed receiver in a metal case! Secondly, the zener diode D1 must be either a 250 mW or a 400 mW type, as stated, as otherwise the input level for the voltage source T1 (3.9 V) will not be correct. This is because the current flowing through D1 is far lower than normal in order to keep the current consumption of the circuit to a minimum. Thirdly, as the output transistors do not require any quiescent current, the value of resistors R13 and R14 are fairly critical. If the stated values are not adhered to the chances are that the output transistors will start to draw current after all and, as there is no temperature compensation network, this could well have a detrimental effect on them. Using the values given in figure 4, transistors T4 and T5 will not have to be cooled. They can be ordinary types without any need for heatsinks.

Results

In practice, the miniature medium waveband receiver was found to perform very satisfactorily. Being a single coil type, it may require constant retuning due to the set 'drifting' off frequency, especially where distant stations are concerned. Even so, it is eminently suitable as a 'stand-by' receiver for news bulletins etc. which is quite often all that is required anyway. It is only when the owner wishes to listen to a weak station in the neighbourhood of a powerful one that the MW receiver is going to have problems. This can often be remedied by turning the receiver towards the weaker station thereby eliminating the stronger one. Local stations can be received very well. In unfavourable circumstances, an external aerial may be experimented with. This should be connected to the top of the tuning coil via a small value capacitor (4p7). This, however, should hardly ever be necessary. If the input signal is clean enough, the sound quality of the receiver will be surprisingly good. In this respect it really stands out amongst similar commercial radios.

Finally, the receiver is remarkably inexpensive. If, like countless other constructors, you have a 'junk' box full of ferrite rods, tuning capacitors and transistors, it will only cost a few pence.

■

text display on the Junior Computer

As we know, the display of the Junior Computer is suitable for displaying both numerical and hexadecimal data. By utilising a seven segment alphabet it is also possible to display written texts. If the text is to be static, a total of six letters are available. If, however a longer message is required, this may 'run' along the display rather like the electronic news display at the top of tall buildings (dynamic text).

from an idea by U. Seyffert

This particular topic receives full attention in Junior Computer Book 2 (to be available shortly), but there is no harm in whetting the appetites of our readers even if it is a little premature.

How can the Junior Computer display words? Normally speaking, data and address information is displayed with the aid of the monitor routine SCANDS. This involves one of the hexadecimal numbers, 0...F, in each display. Where texts are concerned,

however, the monitor routines are no good. What is needed is the subroutine SHOW with the addition of a special look-up table which contains the corresponding seven segment pattern for each individual letter.

Table 1 provides a survey of letters and figures together with the corresponding data which has to be entered into port A for them to be displayed. This table has been partly based on suggestions made to us from one of our readers. Obviously, letters which include diagonal lines (such as K, M, N, Q, V, W, X and Y) will have to be adapted to the horizontal and vertical set up of the display segments. Experience has shown, however, that the eye and the brain soon become accustomed to this.

Now for a short program that will allow a six letter word to appear on permanent display. A good example would be the word 'Junior' as indicated on the prototype of the Junior Computer in the front cover photograph of the May 1980 issue of Elektor and Book 1. The program, JUNIOR, is listed in table 2.

Here the modified SHOW routine will be called SHOWDS and the look-up table that holds the information relating to the display of any particular character is called TXT (text table). The Y index register acts as the display counter and text index. The value contained in the Y register increases from 00 to 05 as an index for the particular character to be displayed. As soon as the value in the Y register becomes 06,

Table 1.

0	40	E	06	o	23
1	79	e	04	P	0C
2	24	F	0E	q	18
3	30	G	42	r	2F
4	19	g (9)	10	S	52
5	12	H	09	S (5)	12
6	02	h	0B	t	07
7	78	i	7A	u	63
8	00	i	6F	V	41
9	10	j	72	W	01
A	08	K	0A	X	36
a	20	L	47	Y	11
b	03	l	4F	Z	64
c	46	M	48	-	3F
C	27	n	2B	=	37
d	21	O (0)	40	sp	7F

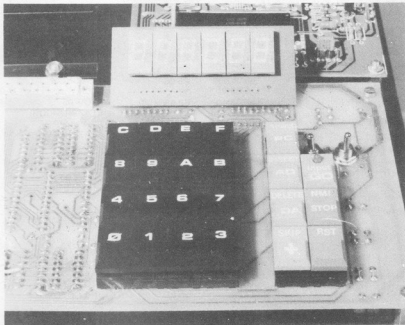

after the instruction INY, it is reset to 00 (jump to DISMPX to begin another round). During the subroutine SHOWDS the Y register contains a delay value which determines the length of time that each display is actually lit. For this reason the previous value contained in the Y register (display counter/text index) must be saved in the address location TEMPY (0004) before the jump to the SHOWDS subroutine takes place.

The function of the X index register, on the other hand, is the same as it was for the SHOW routine: it acts as a display digit switch by way of port B. In other words, the information contained in the

X register (0B, 0A, 0C, 0E, 10 and 12 consecutively) is passed to port B data register to turn each of the displays on in turn.

Text on the run . . .

A stationary text is all very well, but it does tend to get a little monotonous after a while. A much more interesting possibility would be to update the

displayed text every few moments. In this manner whole sentences could be displayed instead of just single words. This can be accomplished with the aid of the program JUNTXT shown in table 3. The effect is very similar to that of an electronic news display. It is an expanded version of the earlier program JUNIOR (table 2). Page 03 is used to store the actual text which can, therefore, be up to 256 characters in length

Table 2.

JUNIOR	0200	A9 7F	LDA # 7F	PA0 . . . PA6 are outputs
	0202	8D 81 1A	STA-PADD	start from DI1
DISMPX	0205	A2 08	LDX # 08	therefore display counter Y = 00
	0207	A0 00	LDY # 00	store display counter
ONEDIS	0209	84 04	STYZ-TEMPY	display first/next character
	020B	20 17 02	JSR-SHOWDS	retrieve state of display counter
	020E	A4 04	LDYZ-TEMPY	increment display counter
	0210	C8	INY	have all 6 displays been accessed?
	0211	C0 06	CPY # 06	if yes, start again
	0213	F0 F0	BEQ DISMPX	if not, next display
	0215	D0 F2	BNE ONEDIS	fetch seven segment code
SHOWDS	0217	B9 30 02	LDA-TXT, Y	place segment code on port A
	021A	8D 80 1A	STA-PAD	turn on display digit
	021D	8E 82 1A	STX-PBD	
	0220	A0 7F	LDY # 7F	
DELAY	0222	88	DEY	delay a short while
	0223	10 FD	BPL DELAY	Y = FF (blanking) to port A
	0225	8C 80 1A	STY-PAD	turn off display
	0228	A0 06	LDY # 06	
	022A	8C 82 1A	STY-PBD	prepare next display digit
	022D	E8	INX	
	022E	E8	INX	
	022F	60	RTS	
TXT	0230	61	"j"	look-up table
	0231	63	"u"	Y = text index
	0232	2B	"n"	(Y = 00 . . . 05)
	0233	6F	"g"	
	0234	23	"o"	
	0235	2F	"r"	

Table 3.

JUNTXT	0200	A9 7F	LDA #7F	
	0202	8D 81 1A	STA-PADD	PA0 . . . PA6 are outputs
	0205	A5 00	LDAZ-NUM	contents NUM (0000) to accumulator
	0207	38	SEC	C = 1
	0208	E9 05	SBC #05	
	020A	85 02	STAZ-NUMCOR	NUMCOR = NUM minus 05
BEGIN	020C	A9 00	LDA = 00	
	020E	85 01	STAZ-NUMVAR	first display text
DSTIME	0210	A9 6F	LDA = 6F	
	0212	85 03	STAZ-DISCONT	establish text display time
DISMPX	0214	A2 08	LDX = 08	start from Di1
	0216	A0 00	LDY = 00	display counter (Y) = 00
ONEDIS	0218	84 04	STYZ-TEMPY	store display counter
	021A	98	TYA	Y to accumulator
	021B	18	CLC	C = 0
	021C	65 01	ADCZ-NUMVAR	A ← Y + contents NUMVAR (0001)
	021E	A8	TAY	accumulator to Y
	021F	20 39 02	JSR-SHOWDS	display first/next character
	0222	A4 04	LDYZ-TEMPY	retrieve state of display counter
	0224	C8	INY	increment display counter
	0225	C0 06	CPY = 06	have all 6 display been accessed?
	0227	F0 02	BEQ TMECHK	if yes, move on to time check
	0229	D0 ED	BNE ONEDIS	if not, next display
TMECHK	022B	C6 03	DECZ-DISCONT	time up?
	022D	D0 E5	BNE DISMPX	if not, repeat present text
	022F	E6 01	INCZ-NUMVAR	if yes, update text
	0231	A5 02	LDAZ-NUMCOR	
	0233	C5 01	CMPZ-NUMVAR	end of text?
	0235	B0 D9	BCS DSTIME	if not, show new text
	0237	90 D3	BCC BEGIN	if yes, start again
SHOWDS	0239	B9 00 03	LDA-TXT, Y	
	023C	8D 80 1A	STA-PAD	
	023F	8E 82 1A	STX-PBD	
	0242	A0 7F	LDY = 7F	
DELAY	0244	88	DEY	
	0245	10 FD	BPL DELAY	see 'JUNIOR' program
	0247	8C 80 1A	STY-PAD	TXT = 0300 (table 4)
	024A	A0 06	LDY = 06	text index = Y + contents NUMVAR
	024C	8C 82 1A	STY-PBD	
	024F	E8	INX	
	0250	E8	INX	
	0251	60	RTS	

— enough for the average length paragraph!

Again, this program uses the subroutine SHOWDIS, only this time the text table (TXT) is located at address 0300 and although the Y register is still used as a display counter it is no longer used as a text index directly. Instead, the particular section of the text to be displayed is calculated by adding the instantaneous value in the Y register to the contents of address location NUMVAR (0001).

The value contained in NUMVAR will be constant for the period of time a certain text is on display (the actual duration can be adjusted by modifying the contents of location 0211). As soon as that period of time is over the contents of NUMVAR are incremented by one: the entire text shifts one location to the left and the right hand display shows a new character. When the contents of NUMVAR are greater than the contents of location NUMCOR, we will have arrived back at the beginning, as this means that the entire

Table 4.

```

0 1 2 3 4 5 6 7 8 9 A B C D E F
0300 7F 7F 7F 7F 7F 07 08 2F 23 01 7F 20 7F 02 7F
0310 01 6F 07 08 7F 07 08 06 7F 61 63 28 6F 23 2F 7F
0320 46 23 48 0C 63 07 06 2F 7F 3F 7F 03 63 11 7F 03
0330 23 23 0A 7F 24 xx xx xx xx xx xx xx xx xx xx
0000 (NUM) = 34

```

text will have been displayed. This is because the contents of NUMCOR are 05 less than those of location NUM. The latter (location 0000) is where the user must store the low order byte of the last memory location of the text table. In other words, if the last character of the text message is stored in location 0332, the value 32 is stored in location 0000 (NUM).

Table 4 provides a sample text which can be displayed on the Junior Computer with the aid of the program JUNTXT as given in table 3. The text contains a message for Junior Computer Book 1 owners. A text should always be preceded by at least six blank spaces (7F), so that the beginning and end of the message are clearly separated from each other. ■

R. de Boer

traffic game

No, this is not a game to play in the middle of the M2. Since it is somewhat safer to simulate traffic situations by electronic means, this game can be used to familiarise inexperienced drivers with the various perils to which they are exposed every day on the road. It enables them to cope without the risk of an accident. In addition, it's fun!

By means of light and sound signals, the player is confronted with all sorts of problems which he has to deal with efficiently in order to cover as many miles as possible within an allotted time. Obviously, this does not mean he can break any traffic regulations on the way.

Present-day traffic is no joke. There are so many vehicles on the roads nowadays, that for safety's sake children should know the rules and regulations practically as soon as they can walk.

Although technological progress has literally taken the weight off our feet, our reflexes are very much overburdened. However, it is impossible to turn back the clock, so we will just have to sharpen our reflexes.

Which is exactly what this traffic game proposes to do. The player learns to react instinctively, automatically after having to face similar situations again and again. What's more he/she can come to grips with unpleasant reality without leaving the safe confines of the living room. In short, an excellent method to teach children.

The rules of the game

Figure 1 shows how the game can be built. A potentiometer with a scale division in miles per hour constitutes the accelerator. A clock generator is controlled by the pot to provide the sound of the engine. The clock frequency is divided, counted, decoded and shown on the display as the number of miles covered.

The main purpose of the game is to drive for as many miles as possible within a certain time. This is not merely a question of putting the foot down on the accelerator, or here, turning the speed up. LEDs are used to represent all sorts of obstacles which the driver

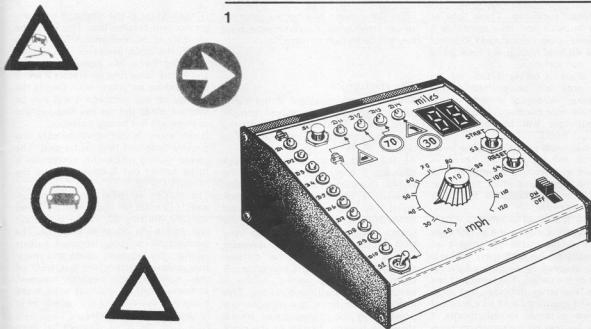

Figure 1. An example showing how the traffic game can be built. The speed at which the 'car' is driven depends entirely on the driver. The mileage is shown on the display. The driver has to keep to all the traffic regulations in order to save time.

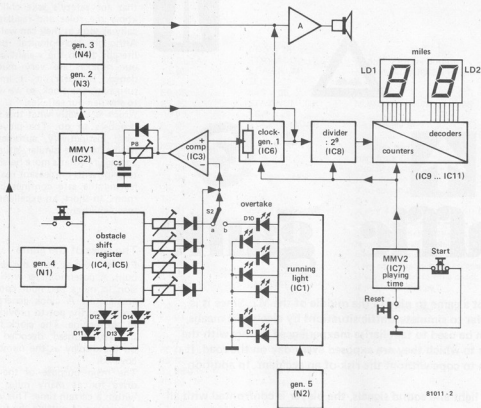

Figure 2. The block diagram of the traffic game circuit.

is likely to encounter. These light at varying intervals and may symbolise a sharp bend, a slow car ahead (30 miles/hour), a 40 mile hour speed limit and a bumpy road surface.

If the driver is taking it too fast, an 'angry' note will be emitted by the loudspeaker. Whenever something goes wrong, the mile counter will come to a halt, but time will continue to run out.

At the beginning of the game, the push-button in the top left-hand corner is depressed to introduce a handicap into the game. The more often this is depressed, the more obstacles the driver will meet en route.

The player is allowed to overtake if he is stuck behind a slow vehicle (30 miles per hour). This makes the game a lot more realistic. An oncoming car will then be imitated by a running light (to the left of the panel). The tenth and last LED in the series indicates that overtaking will inevitably lead to a crash. If the driver is stupid enough to risk it anyway, by putting the switch on 'overtake', this will cost him several seconds. As an oncoming vehicle is difficult to see from a distance, the running light LEDs increase in brightness as they approach the player. Exceeding the maximum speed limit will also cost the driver quite a few seconds.

If for some reason or other the game has to be interrupted, depressing the reset key will be enough to restart it.

The electronics

Since the circuit diagram of the traffic game (figure 3) looks rather complicated, it is a good idea to consider the block diagram first. This is shown in figure 2.

At the heart of the circuit the clock generator 1 provides the sound of the engine. In addition, the number of miles covered is obtained from the clock signal. A monostable multivibrator (MMV2) determines the duration of the game. The handicaps are caused by a shift register. Lighting LEDs represent various regulations and other difficulties the motorist might encounter. A comparator checks whether he/she is keeping to the traffic regulations. This it does by comparing two voltages: one depends on the driving speed and is therefore linearly related to the clock generator's frequency; the other is obtained from the obstacle shift register and determines the maximum speed that can be preset for each obstacle by means of the potentiometers. If the maximum speed is exceeded for too long, the driver is elektorcutted, that

is, the voltage at the output of the comparator will become low. This starts the monostable multivibrator MMV1. As a result, the clock generator (the engine) will stop for a few seconds (penalty) and at the same time generators 2 and 3 will produce an 'angry' note. During the penalty period, generator 4 will also be inactive, since the car has stopped and so there will not be any obstacles.

If an error is corrected quickly, no penalty time will have to be paid. The period during which this correction is to be carried out is determined by the network C5/P8.

The maximum speed limit on motorways (70 miles per hour) can be preset with P9. Putting S2 in the b position will enable the driver to overtake. The 'accelerator' is then depressed a little further, gaining more speed and therefore mileage. Before the last LED of the running light lights, however, (oncoming car) S2 will have to be in the a position as otherwise the car will be in for trouble (penalty time).

Now that the block diagram has been dealt with it won't be necessary to dwell on figure 3 at great length. Since the IC numbers are indicated in the various sections (figure 2) the components can easily be spotted in the circuit diagram. Here and there a few matters still have to be cleared up. Five of the outputs be-

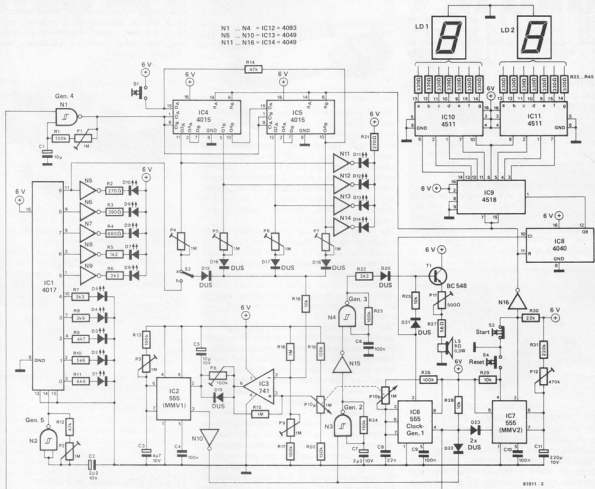

Figure 3. A detailed view of the electronic interior. The purpose of the various switches and potentiometers are described in the text.

longing to the running light (IC1) are buffered with inverters. The other five are not buffered, since these only have to produce a low current. Potentiometers P10a and P10b are mechanically coupled (a stereo potentiometer). This is a simple way to convert the clock frequency into a direct voltage (according to the driving speed). Potentiometer P10b should be connected so that it has minimum resistance when the wiper of P10a is turned towards resistor R20. There are quite a few switches and calibration points in the circuit diagram, so that it is a good idea to have a survey

of their purpose and corresponding functions:

- P1: speed at which the various obstacles follow each other.
- P2: speed of oncoming traffic.
- P3: penalty time.
- P4: speed of slow car ahead (30 miles/per hour).
- P5: maximum speed on poor road surface.
- P6: speed limit.
- P7: sharp bend to the right; maximum speed 35 miles/hour.
- P8: time within which error can be put right without being penalised.

- P9: 70 mile speed limit on motorways.
- P10a + b: driving speed (accelerator).
- P11: volume control of sound of engine and 'angry' tone.
- P12: duration of game.
- S1: obstacle entry (before game is started).
- S2: overtake (position b).
- S3: start.
- S4: reset.
- S5: on/off.

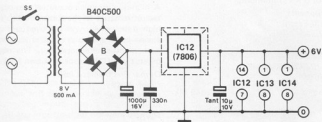

market

Terminal blocks have high insulation properties

New from H & T Components is a series of terminal blocks which offers an extremely high degree of inter-terminal isolation. Designed for applications in electrical and electronic equipment and instrumentation, the Series 110 terminal block is moulded in blue, glassfilled nylon, rated to 105°C maximum. The inter-terminal barriers, while moulded to provide an extremely high degree of protection, allow full access to the terminals and insulators. The terminals themselves are of the standard 2.8 x 0.8 mm size; special terminations measuring 2.8 x 0.5 mm are optionally available.

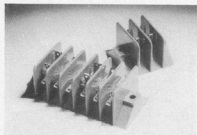

With from one to 12 channels, the Series 110 terminal block can be supplied with two, four or six terminations per channel, secured according to the application requirements: with a solid rivet, as standard; leadthrough insert; or screw insert. Additionally, the moulding may incorporate an anti-rotation spigot.

Electrical characteristics include a maximum current rating of 6 A, and a voltage breakdown level of 6 KV, minimum.

*H & T Components,
Crowdy's Hill Estate,
Kembrey Street,
Swindon,
Wiltshire SN2 6BN,
Telephone: (0793) 693681-7,
Telex: 444166.*

(1849 M)

Mobile radiotelephone system

The new Lynx 2000 range of radiotelephones from Dymar Electronics Ltd. is a British designed and manufactured system which combines applications versatility with very high performance characteristics, particularly in terms of power output and modulation. Offering either amplitude or frequency modulation with up to 20 W of r.f. power on f.m. and 7.5 W on a.m., the Lynx 2000 uses a plug-in approach which means that it can easily be moved from one vehicle to another, or changed to a portable unit or a fixed station pack, in a matter of seconds.

An important feature of the Lynx 2000 system is the wide range of options offered,



which gives a large number of variations on the basic unit and makes the system equally suited to large or smaller users. The 2000 Series can be used as a vehicle-mounted mobile unit, as a plug-in transportable with carrying case, or as a fixed station. In addition to the a.m. and f.m. v.h.f. options, single or two-frequency simplex operation is offered, and other options include single or multiple channels, CTCSS, Selcall signalling and transmission-duration limiters.

The Lynx 2000 Series offers superb amplitude-modulation characteristics, with a modulation depth of at least 90% and very low distortion, achieved by a combination of low-level modulation and negative feedback techniques. As an added bonus, the elimination of the modulation amplifier and its associated transformer gives a more cost effective design.

The latest integrated-circuit techniques are used throughout, with single-board construction providing ease of maintenance. Because the system is British designed and manufactured, and backed by Dymar's well established UK service network, maintenance costs, and hence cost of ownership, are significantly lower than with imported units.

R.F. transmitter power output is 7.5 W for the a.m. model in both mobile and portable modes, and for the f.m. unit is 20 W in the mobile mode, and 7 W in the portable mode, with the lower power selected automatically when it is plugged into the transportable case. Receive power is up to 6 W using an external loudspeaker, with low distortion, or 2 W with less than 5% distortion when using the built-in high-quality weatherproof plastic-cone loudspeaker.

A high-quality voice-operated gain-adjustment circuit is fitted to the transmitter to maintain high 'talk power' without overloading with a strong voice and to prevent undermodulation with a soft-spoken operator. The equipment meets Home Office specification MPT 1302.

*Dymar Electronics Limited,
Colonial Way,
Radlett Road,
Watford,
Herts.
WD2 4LA*

(1854 M)

Medium-size enclosure

The new Pac Tec CM 86-225 enclosure from OK Machine & Tool (UK) Ltd, which measures 8.08in wide x 6.25in deep and 2.5in high (206 mm x 160 mm x 64 mm), is moulded of heavyweight ABS material. Its main feature is a built-in system of component and board mounting bosses and slots to simplify design and assembly and reduce cost of the final product. Units are durable, impact resistant, and self coloured in blue, tan, black and grey, although special colours are available.

Designers can create individual enclosure appearances by combining standard features with options such as special colours, custom trim, special finish, special bezels, EMI/RFI shielding, shoulder strap, tilt stand, rear cord wrap, handle, mounting bracket and custom front and rear panels. Additionally, mouldings can be supplied in UL-listed flame retardant material.

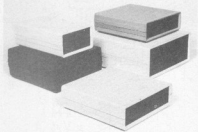

These enclosures also offer the user a unique capability — to create enclosures for prototyping, easily and inexpensively, using special designer kits. The kits contain top and bottom cover, assembly screws, and front and rear panels which can be drilled, punched, cut and silkscreened, and are priced as low as £ 5.83 from stock.

*OK Machine & Tool Ltd,
Dutton Lane,
Eastleigh,
Hants SO5 4AA,
Telephone: 0703 - 610944*

(1857 M)

TP 600 frequency pre-scaler

Designed to provide high sensitivity (better than 10 mV rms) the TP 600 from Thandar will extend the upper frequency limit of most frequency meters by a factor of 10x up to a maximum of 600 MHz.



The TP 600 can be used with the Thandar PFM200 hand-held frequency meter or the Thandar TF 200 L.C.D. frequency meter, to extend their frequency range to cover a wide range of specialised applications, including transmitter/receiver test for mobile and ham radio.

*Sinclair Electronics Ltd,
London Road,
St. Ives,
Huntingdon,
Cambs PE17 4HJ,
England*

(1856 M)

market

Multimeter with automotive functions

A new multimeter, the LMM-400, recently introduced by Lascar Electronics has two extra functions for automotive applications. The instrument features AC/DC Voltage measurement from 0.1 mV to 1 kV and AC/DC current range up to 20 Amps. The resistance measuring range is from 0.1 Ohms to 20 M Ohms.

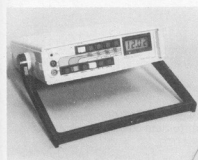

The 'engine' functions are implemented simply by placing the probe between vehicle earth and the LT side of the ignition coil. The instrument will measure RPM (up to 20,000) and will also indicate the ignition dwell angle in degrees. Positive and Negative Earth Vehicles with normal or transistorised ignitions can be tested. Four, Six or Eight cylinder engines are catered for.

The LMM 400 features a 0.5" LCD display, long battery life, fully protected inputs, seven functions with four ranges, and is claimed to be fully suitable for all types of electronic and automotive testing and servicing.

Lascar Electronics Limited,
Unit 1, Thomasin Road,
Burnt Mills, Basildon,
Essex SS13 1LH,
Telephone: Basildon (0268) 727383

(1850 M)

New DC tachometer generator from NECO

A new 'one-piece' design of DC tachometer has been added to the range of high-precision units available from Neco Electronics (Europe) Ltd., Cosham, Hants.

The new 7 volts per 100 rpm, (12,000 rpm maximum) unit (ref ST-7447A-2) is more compact, better sealed and lower in price than equivalent tachometer generators of traditional construction. The generator is in the form of a 'one-piece' housing, with access only from a moulded cover at the non-drive end which also retains the brushes. Construction is therefore simplified and the enclosure is better protected against adverse working conditions.

Like other units in the range it is temperature compensated, suitable for operation in ambient temperatures between -55°C to

+100°C and the voltage output at 25°C will not deviate by more than 0.001 per cent per degree of change within -20°C to +75°C. Linearity at any speed from 0 to 12,000 rpm is said to be better than 0.1 per cent of the output at 3,600 rpm, and an optimum brush and commutator combination ensures exceptional stability. Also, an rms value of ripple of less than 3 per cent of the DC value at any speed in excess of 40 rpm, and bi-directional output within 0.25 per cent of nominal output are claimed. An important feature, thought to be unique, is that brushes and commutators are guaranteed for 100,000 hours at 3,600 rpm, 1 mA maximum current.

Normand Electrical Company Ltd.,
Walton Road,
Eastern Road,
Cosham,
Hampshire PO6 1SZ,
Telephone: 0705-370988

(1853 M)

RCA launches £ 138 single-board computer

The latest addition to the RCA Solid State range of Microboard single-board computers is the CDP 18S604, which costs only £ 138 (plus V.A.T.). Featuring very low power consumption and simplicity of use, it is a complete computer system on a 4.5 x 7.5-inch card.

The new device contains a CDP1802 C-MOS microprocessor, a 2 MHz crystal-controlled clock, 512-bytes of read-write memory, parallel input/output ports, power-on reset, an interface expansion area, and a socket for 1 or 2 kbyte of user-selected read-only memory.

The CDP 18S604 has all the inherent advantages of lowpower static C-MOS circuitry and the COSMAC microprocessor architecture. Powered from a single 5 V supply, it requires only 4 mA when populated with a C-MOS read-only memory.

The CDP 18S604 is designed to provide the key hardware for a variety of low-cost micro-computer applications, enabling the designer to concentrate on software development and the special requirements of his specific application.

Two CDP 18S2's are used to provide eight parallel input and eight parallel output lines. It has four flag inputs and a Q serial data output. All the input/output lines are on edge connectors.

The new low-priced Microboard computer is compatible with both the CDP 18S005 and CDP 18S007 COSMAC Development Systems, facilitating prototype design and the debugging of both hardware and software. Like all the other RCA Microboard products, it is expandable by use of the 44-pin COSMAC Microboard universal backplane. Power can be applied either through the interface expansion area or through the input/output connector. Because of its static C-MOS components, it features high noise immunity and is therefore capable of operation in severe industrial environments.

RCA Solid State-Europe,
Sunbury-on-Thames,
Middlesex,
TW16 7HW.

(1845 M)

Self-adhesive temperature indicators

These strip indicators from Thermindex Chemicals and Coatings show temperatures in both centigrade and fahrenheit. In use the strip adheres to the surface under examination and the indicators change from silver grey to black as the temperature rises. The change is virtually instantaneous and the indication is to an accuracy of ± 1% of the calibrated value.

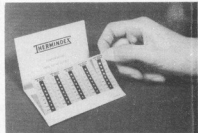

These indicators are ideal for checking almost any surface temperature and are water and oil resistant.

Thermindex Chemicals and Coatings Ltd.,
P.O. Box 112,
Imperial Way,
Watford,
Telephone: Watford 28363

(1870 M)

'Rotary' electronic case

An unusual and versatile new product - the ORBIX Rotary Electronic Case - has just been introduced by Dattur Ltd. Instead of the usual square or rectangular shape, the Orbix is a steel case with a difference - it's round - and it swivels, looking at every 15 degrees when moved allowing for changes in the field of view. The Orbix can be wall mounted, suspended from a ceiling or just simply installed on the floor or desk.

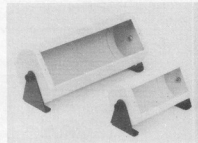

An anti-dazzle mask is included among the range of accessories - which makes reading of possible built-in LED displays easier. The system includes; Case, Rear panel/rear panel with opening, 2 feet, 2 knurled screws and 4 adhesive feet. Standard colour is beige but alternative colours are available.

Dattur Ltd.,
Unit E,
Roan Industrial Estate,
Mortimer Road,
Mitcham,
Surrey CR4 3HS,
Telephone: 01-646 2766,
Telex: 929949

(1872 M)

CLASSIFIED

CONDITIONS OF ACCEPTANCE OF CLASSIFIED ADVERTISEMENTS

1. Advertisements are accepted subject to the conditions appearing on our current rate card and on the express understanding that the Advertiser warrants that the advertisement does not contravene any Act of Parliament nor is it an infringement of the British Code of Advertising Practice.

2. The Publishers reserve the right to refuse or withdraw any advertisement.

3. Although every care is taken, the Publishers shall not be liable for clerical or printer's errors or their consequences.

4. The Advertiser's full name and address must accompany each advertisement submitted.

The prepaid rate for Classified Advertisements is 20 pence per word (minimum 12 words). Semi-display setting £5.50 per single column centimetre (minimum 2.5 cms.). All cheques, postal orders, etc. to be made payable to Elektor Publishers Ltd. Treasury notes should always be sent by registered post. Advertisements, together with remittance, should be sent to the Classified Advertisement Manager, Elektor Publishers Ltd., 10 Longport, Canterbury, Kent CT1 1PE.

PRINTED CIRCUITS. Make your own simply, cheaply and quickly! Golden Fotolak Light Sensitive Lacquer - now greatly improved and very much faster. Aerosol cans with full instructions - £2.25. Developer - 35p. Ferric Chloride - 55p. Clear Acetate sheet for master 14p. Copper-clad Fibre-glass Board approx. 1mm thick - £1.75 sq. ft. Post & Packing 60p.

WHITE HOUSE ELECTRONICS,
P.O. BOX 19,
PENZANCE, CORNWALL.

CLEARANCE PARCELS:
TRANSISTORS, RESISTORS,
BOARDS, HARDWARE, 101 lbs. -
only **£5.80!**
1000 RESISTORS **£4.25**
500 CAPACITORS **£3.75**
BC108, BC171, BC204, BC230,
2N5061, CV7497 TRANSISTORS
10 **70p** 100 **£5.80**
2N3055, 10 for **£3.50**, S.A.E. for
lists: W.V.E. (4),
15 HIGH STREET, LYDNEY,
GLOUCESTER.

TELEPHONE answering machines
from £75.00, **FLIPPONES** £25.00
WATCHES, gents and ladies, from
£5.75. **CAR RADIO/CASSETTES,**
BOOSTERS, SPEAKERS, AER-
IALS, WALKIE-TALKIES down to
earth prices. Send SAE for details:
H.P. SUPPLIES,
162 LONDON ROAD,
WEMBLEY, MIDD.

MODERN BARGAINS - S.A.E.
Early radios.
SOLE ELECTRONICS,
37 STANLEY STREET,
ORMSKIRK, LANCS. L39 2DH.

BALLARD'S, Tunbridge Wells, have
moved to **54 GROSVENOR ROAD,**
TUNBRIDGE WELLS, KENT.
Phone 0892 31803.

DISK DRIVES £ 135

5¼ inch double-density, 40-track
disk drive giving you 250k bytes
of unformatted storage. Shugart
compatible. Removed from brand
new equipment, fully tested and
aligned. Three months' warranty.
£135 each, post & packing £3.
Data sheets 50p. Manual & circuit
£9.50.

DISKETTES £2.95

Maxell 5¼ inch double-density
floppy disks. Compatible with all
35 and 40 track single-sided, soft-
sectored drives.
£2.95 each, post & packing 30p.
£28 for box of ten, post & packing
80p.

DOUBLE-SIDED DISKETTES

£3.50

Maxell double-sided, double-
density disks. £3.50 each, post &
packing 30p.
£33 for box of ten, post &
packing 80p. Please add VAT to
all prices. Send cheque or P.O. to:

Helistar Systems Ltd.,
150 Weston Rd., Aston Clinton,
Aylesbury, Bucks, HP22 5EP.
Tel: Aylesbury (0296) 630364

ADVERTISERS INDEX

Chartpak	UK 09
Coiltronic	UK 08
Doram Electronics	UK 07
Electronics and Music Maker	UK 17
Electrovalue	UK 08
Gailan	UK 15
Keytronics	UK 18
Maplin	UK 02
Marshall's UK 13	
Microcircuits	UK 12
G.F. Milward	UK 15
Phononics	UK 09
T. Powell	UK 24
Ramar	UK 08
Science of Cambridge	UK 10/UK 11
Suretron Systems	UK 08
Technomatic	UK 23
TK Electronics	UK 19

WHO AND WHERE

A DIRECTORY OF ELECTRONIC COMPONENT SUPPLIERS TO ELEKTOR READERS



AREA 1

AITKEN BROS. & CO.
35 High Bridge
Newcastle-upon-Tyne
NE1 1EW
Tel. 0632 26729

ALPHA SOUND SERVICES
50 Stuart Rd, Waterloo
Liverpool 22
Tel. 051 928 7862

A. MARSHALL (LONDON) LTD
85 West Regent Street
Glasgow G2 2QD
Tel. 041 332 4133

THE AMATEUR RADIO SHOP
4 Cross Church Street
Huddersfield HD1 3PT
Tel. 20774

N.R. BARDWELL LTD.
288 Abbeydale Road
Sheffield 7
Tel. Sheffield 52886

S. BELL TV SERVICES
190 Kings Road
Harrogate HG1 5JG
Tel. Harrogate 55885

CASEY BROTHERS
Palladium House
Boundary Road
St. Helens
Merseyside WA10 2LL
Tel. 0744 27873

DERWENT RADIO
5 Columbus Ravine
Scarborough, N. Yorkshire
Tel. 0732 63982

D.I.M.E.S. ELECTRONICS
Hobby Shop
83 Broad Street
Peterhead
Aberdeenshire AB4 6JL
Tel. 0779 77515

ELECTRONIC ASSEMBLY SERVICES
Bright Street Works
Bury, Lancs. BL9 6AQ
Tel. 061 764 7634

ELECTROVALUE LTD.
680 Burnage Lane
Manchester M19 1NA
Tel. 061 432 4945

ELECTRO SUPPLIES
6A Todd Street
Manchester
Tel. 061 834 1185

GREENBANK ELECTRONICS
94 New Chester Road
New Ferry, Wirral
Merseyside L62 5AG
Tel. 051 645 3391

SUDEHILL SUPPLY CO. LTD
53 Shudehill
Manchester M4 4AW
Tel. 061 834 1449

SPECTRON ELECTRONICS
MANCHESTER LTD.
7 Oldfield Road, Salford
Greater Manchester
Tel. 061 834 4583

PROGRESSIVE RADIO
93 Dale Street
Liverpool L2 2JD
Tel. 051 236 0982

AREA 2

CRYSTAL ELECTRONICS
40 Magdalen Road
Torquay, Devon
Tel. 22699

DURRANT RADIO
(COMPONENT SERVICE)
9 St. Mary's Street
Shrewsbury, Shropshire
Tel. 61239

P.A.T.H. Electronic Services
369 Alum Rock Road
Birmingham B8 3DR
Tel. 021 327 2339

G.M.T. ELECTRONICS
P.O. Box 290
8 Hampton Street
Birmingham B19 3JR
Tel. 021 233 2400

L.F. HANNEY
77 Lower Bristol Road
Bath BA2 3BS, Avon
Tel. 0225 24811

A. MARSHALL (LONDON) LTD
108A Stokes Croft
Bristol
Tel. 0272 426801

MONOLITH ELECTRONICS
CO. LTD.
5/7 Church Street
Crewkerne, Somerset
Tel. 0460 74321

RAMAR ELECTRONIC SERVICES LTD.
Masons Road
Stratford-on-Avon
CV37 9NF
Tel. 4879

STEVE'S ELECTRONICS
15/17 The Balcony
Castle Arcade, Cardiff
Tel. 0222 41905

AREA 3

A. MARSHALL (LONDON) LTD
40/42 Cricklewold Broadway
London NW2 3ET
Tel. 01 452 0161
325 Edgware Road
London W2
Tel. 01 723 6422

AMBIT INTERNATIONAL
200 North Service Road
Brentwood, Essex
Tel. 0277 230909
Telex 995194 Ambit G

ARROW ELECTRONICS
Coptford Road
Brentwood, Essex
Tel. 0277 219435

AUDIO ELECTRONICS
301 Edgware Road
London W2 1BN
Tel. 01 724 3564

BI-PAK SEMICONDUCTORS
3 Baldock Street
Ware, Herts.
Tel. 0920 61593

CAVERN ELECTRONICS
94 Stratford Road
Wolverton, Milton Keynes
Tel. Milton Keynes 314925

CHARLES TOWN
89 Carrington Street
Nottingham
Tel. 868933 & 55489

CHROMASONIC ELECTRONICS LTD.
56 Fortis Green Road
Muswell Hill
London N10 3HN
Tel. 01 883 3705/2289

CONTOUR ELECTRONICS
23 High Street
Stansted Abbots
Ware, Herts.
Tel. 0279 415717

CONTINENTAL SPECIALTIES CORP. (UK) LTD.
Shire Hill Industrial Estate
Saffron Walden
Essex CB11 3AQ
Tel. 0799 21682

COSSOR ELECTRONICS
The Pinnacles
Elizabeth Way, Harlow
Essex CM19 5BB
Tel. 0279 26862

C.T.S. LTD.
20 Chatham Street
Ramsgate, Kent CT11 7PP
Tel. Thanet 54072

D.P. HOBBS
11 King Street
Luton, Beds.
Tel. 0582 20907

DORAM ELECTRONICS
Fitzroy House
Market Place
Swaffham
Norfolk PE37 7QH
Tel. 0760 21627

ELECTROVALUE LTD.
28 St. Judes Road
Englefield Green
Egham, Surrey TW20 0HB
Tel. Egham 3603

ELEY ELECTRONICS
100/104 Beatrice Road
Leicester
Tel. 871522

FRANK MOZER LTD.
5 Angel Corner Parade
Edmonton, London N18
Tel. 01 807 2784

FOREWAY SERVICES
19 Old High Street
Headington, Oxford
Tel. 0865

G.B. GARLAND BROS. LTD.
Chesham House
Depford Broadway
London SE8 4QN
Tel. 01 692 4412

GREENWELD ELECTRONICS
443E Millbrook Road
Southampton SO1 0HX
Tel. 0703 772501

HARRINGTON COLOR-VISION
9 Queen Street
Colchester, Essex
Tel. Colchester 47503

HENRY'S RADIO
404 Edgware Road
London W2
Tel. 01 723 5095

J.T. FILMER
82 Dartford Road
Kent DA1 3ER
Tel. 0322 24057

KAYS ELECTRONICS
195 Sheffield Road
Chesterville, Derbyshire
Tel. 0246 31696

MAPLIN ELECTRONIC SUPPLIES LTD.
P.O. Box 3
Rayleigh, Essex SS6 8LR
Tel. 0702 552911
Shops at:
159-161 King Street
Hammersmith
London W6
Tel. 01 748 0926
and
284 London Road
Westcliff-on-Sea, Essex
Tel. 0702 554000