

up-to-date electronics for lab and leisure
ELEKTOR 14

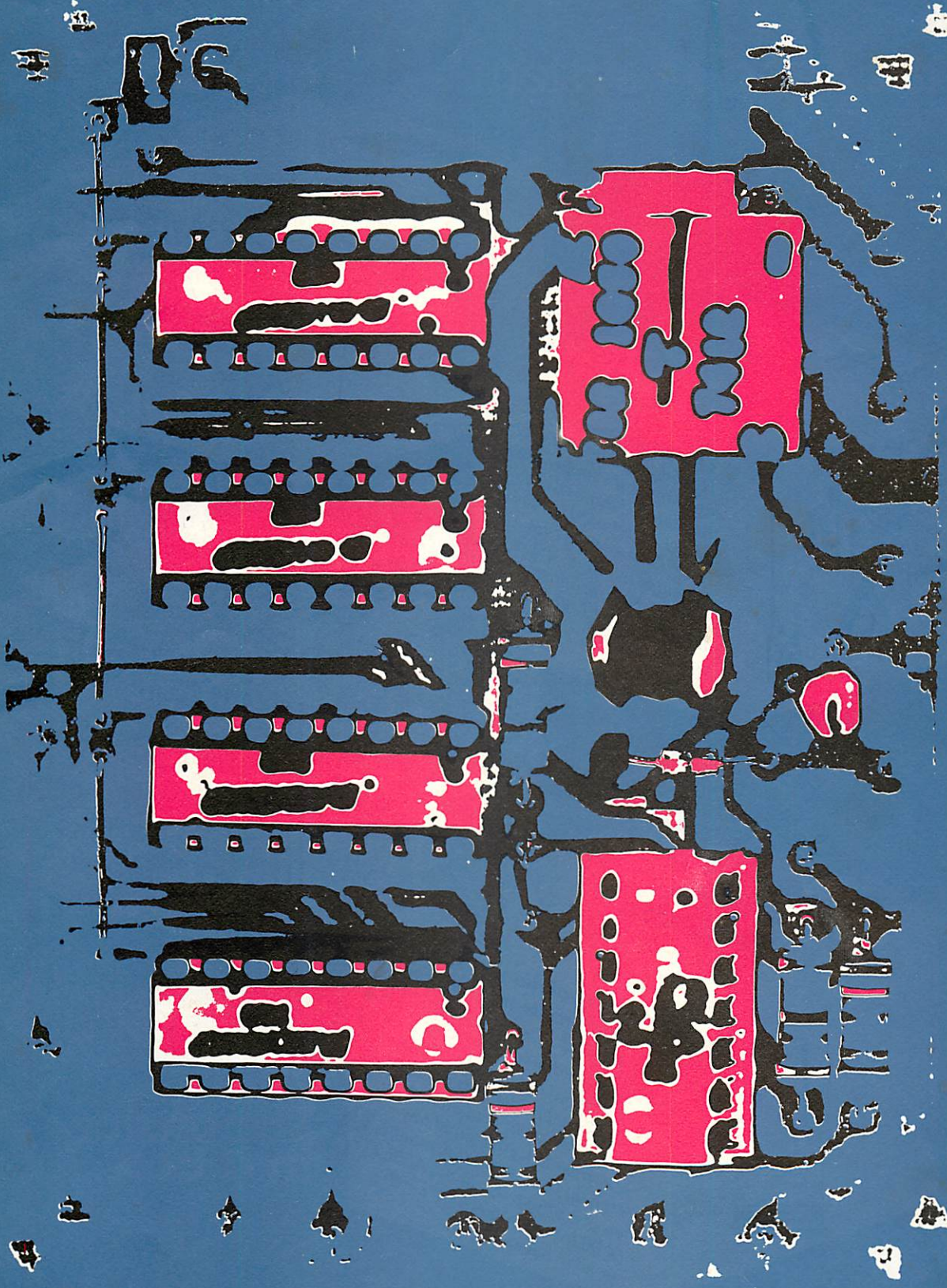

The easy way to a PCB...

...the Seno 33 system!

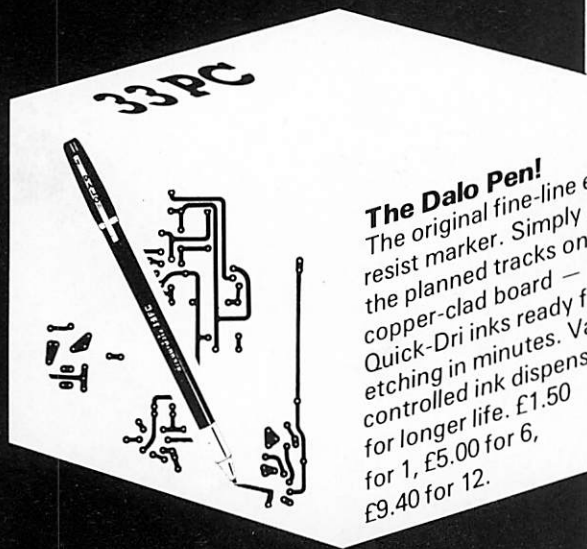

The Dalo Pen!
The original fine-line etch resist marker. Simply draw the planned tracks onto the copper-clad board — new Quick-Dri inks ready for etching in minutes. Valve controlled ink dispensing for longer life. £1.50 for 1, £5.00 for 6, £9.40 for 12.

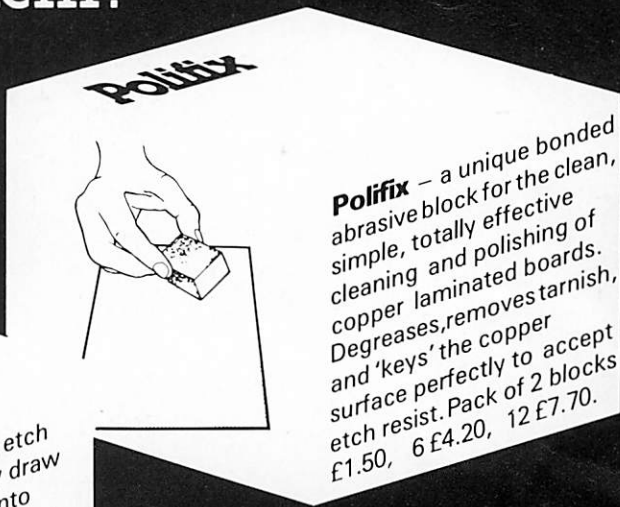

Polifix — a unique bonded abrasive block for the clean, simple, totally effective cleaning and polishing of copper laminated boards. Degreases, removes tarnish, and 'keys' the copper surface perfectly to accept etch resist. Pack of 2 blocks £1.50, 6 £4.20, 12 £7.70.

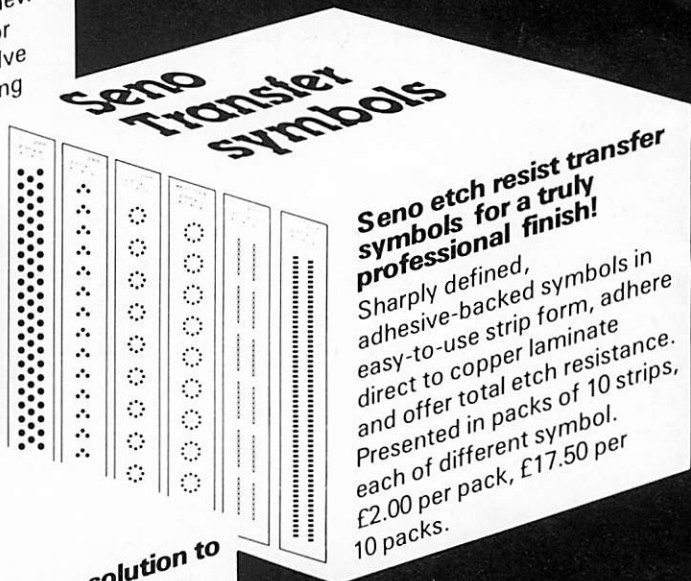

Seno etch resist transfer symbols for a truly professional finish!
Sharply defined, adhesive-backed symbols in easy-to-use strip form, adhere direct to copper laminate and offer total etch resistance. Presented in packs of 10 strips, each of different symbol. £2.00 per pack, £17.50 per 10 packs.

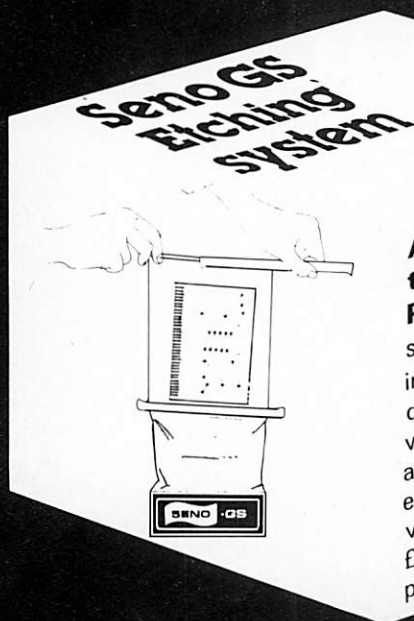

A revolutionary solution to the problems of etching PCBs! Unique sealed system minimises the risk, inconvenience, storage and disposal problems associated with the use of acid etchants — a complete kit designed to etch up to eight boards rapidly, visibly, effectively and SAFELY! £4.00 for a complete kit, £3.45 per kit in packs of 6.

Seno33 — The Laboratory in a box

From your usual component supplier or direct from:

DECON LABORATORIES LTD.
Ellen Street, Portslade,
Brighton BN4 1EQ
Telephone: (0273) 414371
Telex: IDACON BRIGHTON 87443

EPS PRINT SERVICE

circuit	number	issue	price	% VAT
AUDIO				
austereo 3-watt amplifier	HB11	5	1.15	(12.5)
austereo power supply	HB12	5	0.55	(12.5)
austereo control amplifier	HB13	5	1.55	(12.5)
austereo disc preamp	HB14	5	0.65	(12.5)
edwin amplifier	97-536	6	1.25	(12.5)
miniature amplifier	1486	6	0.55	(12.5)
equa amplifier	1499	1	1.55	(12.5)
equin	9401*	13	2.15	(12.5)
tap preamp	4003	4	1.95	(12.5)
tap power	9072*	7	2. —	(12.5)
tap preamp front panels:				
power	1626A	7	1.65	(12.5)
input	1626B	4	1.65	(12.5)
volume	1626C	4	1.65	(12.5)
tone	1626D	4	1.65	(12.5)
width	1626E	4	1.65	(12.5)
730/740 (IC control amplifier)	9191*	8	1.15	(12.5)
disc preamp 76131	4040A	3	1.05	(12.5)
preco, preamplifier	9398*	13	2. —	(12.5)
preco, control amplifier	9399*	13	1.15	(12.5)
dnl	1234	11	0.85	(12.5)
electronic loudspeaker	1527	2	0.55	(12.5)
compressor	6019A	3	1.50	(12.5)
RF				
coilless receiver for MW and LW	3166	5	0.85	(12.5)
super-plam, main p.c.b.	6012-1b	11	2.05	(12.5)
super-plam, detector a	6012-2a	11	1.10	(12.5)
super-plam, detector b	6012-3a	11	1.25	(12.5)
ssb receiver	6031*	11	2.25	(12.5)
mini MW receiver	9369*	9	0.70	(12.5)
FM/TV				
pll stereo decoder MC1310P	1477	9	0.75	(12.5)
CA3090AQ stereo decoder	9126*	5	0.80	(12.5)
tv sound	6025	2	1.75	(12.5)
tv sound, front-end	9357*	11	1.30	(12.5)
ota pll	6029	7	1.15	(12.5)
feedback pll fm receiver (3 boards)	9356*	9	4.05	(12.5)
aerial amplifier	1668	1	1.15	(12.5)
integrated indoor fm aerial	9423*	13	0.80	(12.5)
CARS				
car power supply	1563	4	1.50	(8)
digital rev counter (control p.c.b. only!)	1590	1	1.35	(8)
car anti-theft alarm	1592	4	1.70	(8)
GAMES				
beetle	1492	4	2.35	(8)
tv tennis, main pcb	9029-1A*	7	4.40	(8)
tv tennis, modulator/oscillator	9029-2*	7	1.05	(8)
tv tennis, 5-volt supply	9218A*	7	0.90	(8)
tv tennis extensions	9363*	13	5.15	(8)
die	9169*	8	0.80	(8)
RHYTHM AND SOUND				
minidrum gyrator	1465A	2	0.95	(12.5)
minidrum mixer/preamp	1465B	2	0.60	(12.5)
minidrum noise	1465C	2	1.25	(12.5)
minidrum tap	1621A	2	0.90	(12.5)
minidrum ruffle circuit	1621B	3	1.15	(12.5)
automatic bassdrum	1621C	3	0.90	(12.5)
microdrum	1661	2	1.05	(12.5)
rhythm generator (M252AA)	9110*	5/12	0.90	(12.5)
rhythm generator (M253AA)	9344-3*	12	1.20	(12.5)
ic drummer, instruments mother board	9344-2*	12	1.70	(12.5)
ic drummer, instruments daughter board	9344-1*	12	0.30	(12.5)
screening for master oscillator	4011A	10	0.30	(12.5)
master oscillator AY10212	4011B-2	10	1.30	(12.5)
ancillary supply for m.o.	4011B-13	10	0.95	(8)
big ben 95	5028	2	1.50	(12.5)
7400 siren	9119*	5	0.80	(12.5)

Many Elektor circuits are accompanied by designs for printed circuits. For those who do not feel inclined to etch their own printed circuit boards, a number of these designs are also available as ready-etched and predrilled boards. These boards can be ordered from our Canterbury office. Payment, including £ 0.15 p & p, must be in advance. Delivery time is approximately three weeks. Bank account number: A/C No. 11014587, sorting code 40-16-11 Midland Bank Ltd, Canterbury.

circuit	number	issue	price	% VAT
TIME-KEEPING				
mos clock 5314 clock circuit	1607A	1	1.65	(8)
mos clock 5314 display board	1607B	1	1.20	(8)
mos clock timebase	1620	4	0.85	(8)
versatile digital clock	4414B	6	1.40	(8)
clamant clock, alarm	4015-13	7	1.45	(8)
clamant clock, time signal	4015-16	7	1. —	(8)
clamant clock, striking system	4015-27	8	1.35	(8)
car clock (2 boards)	7036	6	2.20	(8)
car clock front panel (transparent red plastic)	7036-3	6	1.15	(8)
kitchen timer	9147*	5	0.85	(8)
digital watch (date only)	9397-1*	10	0.80	(8)
digital watch (day/date)	9397-2*	10	0.80	(8)
DISPLAYS				
twin minitron display	4029-1	2	1.95	(8)
twin led display	4029-2	2	1.95	(8)
twin decade counter	4029-3	2	1.95	(8)
maxi display	4409	2	2. —	(8)
UAA170, 270° meter, basic board	9392-1*	12	1.40	(8)
UAA170, 270° meter, front panel	9392-2	12	1.90	(8)
TEST EQUIPMENT				
universal frequency reference	HD4	5	1.40	(8)
distortion meter	1437	1	2.20	(8)
a/d converter	1443	3	1.05	(8)
recip-riaa	4039	2	0.90	(8)
dil-led probe	5027A+B	2	2.45	(8)
frequency counter, control logic	9033*	7	1.50	(8)
frequency counter, minitron display board	9312*	7	1.30	(8)
frequency counter, led display board	9313*	7	1.30	(8)
frequency counter, counter/ latch/display driver	9314*	7	1.05	(8)
frequency counter preamp	9031-1*	8	1.30	(8)
frequency counter, -5 V supply	9031-2*	8	0.85	(8)
tup/tun tester	9076*	4	2.05	(8)
tup/tun tester front panel	9076/2A	4	2.30	(8)
p.c.b. and wiring tester	9106*	5	0.60	(8)
fm test generator	9155*	10	0.85	(8)
capacitance meter	9183*	5	0.85	(8)
versatile logic probe	9329*	13	1.05	(8)
UAA170, LED voltmeter, basic board	9392-3*	12	1. —	(8)
UAA170, 16 LED display board	9392-4*	12	0.85	(8)
MISCELLANEOUS				
tap sensor	1457	1	0.85	(8)
mostap	1540	2	1.30	(8)
light dimmer	1487	6	0.55	(8)
ttl +5 V supply	4046	7	1.05	(8)
integrated voltage regulator	7043b	11	0.80	(12.5)
automatic call-sign generator	9017*	10	2.85	(8)
stylus balance	9343	12	0.40	(12.5)
polaroid timer	9379*	12	1.20	(12.5)
NEW				
digibell	9325*	14	1.90	(8)
led light show	9403*	14	2.55	(8)
fet front, preamp	9413*	14	0.80	(8)
fet front, probe	9427*	14	0.70	(8)

* with solder mask

All prices include VAT at the rate shown in brackets.

elektor decoder

What is a TUN?
What is 10 n?
What is the EPS service?
What is the TQ service?
What is a missing link?

Semiconductor types

Very often, a large number of equivalent semiconductors exist with different type numbers. For this reason, 'abbreviated' type numbers are used in Elektor wherever possible:

- '741' stands for μ A741, LM741, MC741, MIC741, RM741, SN72741, etc.
- 'TUP' or 'TUN' (Transistor, Universal, PNP or NPN respectively) stands for any low frequency silicon transistor that meets the specifications listed in Table 1. Some examples are listed below.
- 'DUS' or 'DUG' (Diode, Universal, Silicon or Germanium respectively) stands for any diode that meets the specifications listed in Table 2.
- 'BC107B', 'BC237B', 'BC547B' all refer to the same 'family' of almost identical better-quality silicon transistors. In general, any other member of the same family can be used instead. (See below.)

For further information, see 'TUP, TUN, DUG, DUS', Elektor 12, p. 458.

Table 1. Minimum specifications for TUP (PNP) and TUN (NPN).

$V_{CEO,max}$	20V
I_C,max	100 mA
$h_{fe,min}$	100
$P_{tot,max}$	100 mW
f_T,min	100 MHz

Some 'TUN's are: BC107, BC108 and BC109 families; 2N3856A, 2N3859, 2N3860, 2N3904, 2N3947, 2N4124. Some 'TUP's are: BC177 and BC178 families; BC179 family with the possible exception of BC159 and BC179; 2N2412, 2N3251, 2N3906, 2N4126, 2N4291.

Table 2. Minimum specifications for DUS (silicon) and DUG (germanium).

	DUS	DUG
V_R,max	25V	20V
I_F,max	100mA	35mA
I_R,max	1 μ A	100 μ A
$P_{tot,max}$	250mW	250mW
C_D,max	5pF	10pF

Some 'DUS's are: BA127, BA217, BA218, BA221, BA222, BA317, BA318, BAX13, BAY61, 1N914, 1N4148.

Some 'DUG's are: OA85, OA91, OA95, AA116.

BC107 (-8, -9) families:
BC107 (-8, -9), BC147 (-8, -9), BC207 (-8, -9), BC237 (-8, -9), BC317 (-8, -9), BC347 (-8, -9), BC547 (-8, -9), BC171 (-2, -3), BC182 (-3, -4), BC382 (-3, -4), BC437 (-8, -9), BC414

BC177 (-8, -9) families:

BC177 (-8, -9), BC157 (-8, -9), BC204 (-5, -6), BC307 (-8, -9), BC320 (-1, -2), BC350 (-1, -2), BC557 (-8, -9), BC251 (-2, -3), BC212 (-3, -4), BC512 (-3, -4), BC261 (-2, -3), BC416.

Resistor and capacitor values

When giving component values, decimal points and large numbers of zeros are avoided wherever possible.

The decimal point is usually replaced by one of the following international abbreviations:

p (pico-) = 10^{-12}
n (nano-) = 10^{-9}
 μ (micro-) = 10^{-6}
m (milli-) = 10^{-3}
k (kilo-) = 10^3
M (mega-) = 10^6
G (giga-) = 10^9

A few examples:

Resistance value 2k7: this is 2.7 k Ω , or 2700 Ω .

Resistance value 470: this is 470 Ω .

Capacitance value 4p7: this is 4.7 pF, or 0.000 000 000 004 7 F . . .

Capacitance value 10 n: this is the international way of writing 10,000 pF or .01 μ F, since 1 n is 10^{-9} farads or 1000 pF.

Mains voltages

No mains (power line) voltages are listed in Elektor circuits. It is assumed that our readers know what voltage is standard in their part of the world! Readers in countries that use 60 Hz should note that Elektor circuits are designed for 50 Hz operation. This will not normally be a problem; however, in cases where the mains frequency is used for synchronisation some modification may be required.

Technical services to readers

- **EPS service.** Many Elektor articles include a lay-out for a printed circuit board. Some — but not all — of these boards are available ready-etched and predrilled. The 'EPS print service list' in the current issue always gives a complete list of available boards.

— Technical queries.

Members of the technical staff are available to answer technical queries (relating to articles published in Elektor) by telephone on Mondays from 14.00 to 16.30. Letters with technical queries should be addressed to: Dept. TQ. Please enclose a stamped, self addressed envelope; readers outside U.K. please enclose an IRC instead of stamps.

- **Missing link.** Any important modifications to, additions to, improvements on or corrections in Elektor circuits are generally listed under the heading 'Missing Link' at the earliest opportunity.

ELEKTOR

14

Volume 2
Number 6

Editor : W. van der Horst
Deputy editor : P. Holmes
Technical editors : J. Barendrecht
G.H.K. Dam
E. Krempelsauer
Fr. Scheel
K.S.M. Walraven
Art editor : C. Sinke
Drawing office : L. Martin
Subscriptions : Mrs. A. van Meyel

UK editorial offices, administration and advertising:
6 Stour Street, Canterbury CT 1 2XZ.
Tel. Canterbury (0227) — 54430.
Telex: 965504.

Bank: Midland Bank Ltd Canterbury A/C no. 11014587,
Sorting code 40-16-11, giro: no. 315 4254.

Assistant Manager and Advertising : R.G. Knapp
Editorial : T. Emmens

Elektor is published monthly on the third Friday of each month, price 40 pence.

Please note that number 15/16 (July/August) is a double issue, 'Summer Circuits', price 80 pence. Single copies (including back issues) are available by post from our Canterbury office to UK addresses and to all countries by surface mail at £ 0.55.

Single copies by air mail to all countries are £ 0.90. Subscriptions for 1976 (January to December inclusive): to UK addresses and to all countries by surface mail: £ 6.25, to all countries by air mail £ 11,—.

Subscriptions for 1976 (July/August to December inclusive): to UK addresses and to all countries by surface mail: £ 3.05. All prices include p & p.

Subscribers are requested to notify a change of address four weeks in advance and to return envelope bearing previous address.

Letters should be addressed to the department concerned: TQ = Technical Queries; ADV = Advertisements; SUB = Subscriptions; ADM = Administration; ED = Editorial (articles submitted for publication etc.); EPS = Elektor printed circuit board service. For technical queries, please enclose a stamped, addressed envelope.

The circuits published are for domestic use only. The submission of designs or articles to Elektor implies permission to the publishers to alter and translate the text and design, and to use the contents in other Elektor publications and activities. The publishers cannot guarantee to return any material submitted to them. All drawings, photographs, printed circuit boards and articles published in Elektor are copyright and may not be reproduced or imitated in whole or part without prior written permission of the publishers.

Patent protection may exist in respect of circuits, devices, components etc. described in this magazine. The publishers do not accept responsibility for failing to identify such patent or other protection.

Distribution: Spotlight Magazine Distributors Ltd.,
Spotlight House 1, Bentwell road, Holloway,
London N7 7AX.

Copyright © 1976 Elektor publishers Ltd — Canterbury.

Printed in the Netherlands.

contents

selektor	608
channel quadrupler — Dipl. Ing. H. Weidner	610
A single-beam oscilloscope is often insufficient nowadays for testing electronic circuits. This article describes a multi-channel switch with which four signals may be displayed simultaneously.	
measuring pencil — J. Hájek	612
vhf fm reception	613
Owners of FM tuners may often wish to know what sort of signal level they can expect to receive in the locality in which they live. This article investigates the rules governing VHF propagation and shows how received signal strengths may be estimated with a few simple calculations.	
triac control	617
a.m. mains intercom	618
Mains intercoms of a more or less reasonable quality are still a bit expensive on the market. Consequently, there appears to be a fair demand for a cheap a.m. intercom which will be useful in certain applications where mains interference is not excessive.	
fet front	620
HF preamp and FET probe for frequency counter.	
missing link: link 75	624
ejektor	625
An invitation to investigate, improve on and implement imperfect but interesting ideas.	
vertical fets	628
The Japanese have now developed a semiconductor called 'vertical field effect transistor', intended for use in high power output stages. This article describes the V-FET's construction and operation, along with its application in commercial circuits.	
led light show	634
Small is beautiful, as they say, and the LED light show can brighten up the front panel of an amplifier, tuner or tape recorder.	
digibell — R. Janssen	638
A design for an electronic doorbell that plays the well-known 'Westminster Chime'. The only tuning necessary is a single adjustment to set the entire melody in the required key.	
market	641

Candis Limited

ELECTRONIC COMPONENT DISTRIBUTORS

P.O. Box 25 Canterbury Kent

Telephone: Canterbury (0227) 52139

Elektor

printed circuit boards and binders.

Prices as in this issue

Component kits and individual components available by return of post from stocks at Canterbury. All prices include VAT and P.+P.

741-8/14DIL	£0.22	E.1109	£6.08
7400	£0.15	7038A	£3.68
7401	£0.15	TBA231	£1.02
7405	£0.19	CA1310AE	£2.27
7447	£1.20	CA3080	£0.79
7473	£0.30	CD4011AE	£0.23
7495	£0.69	CD4017AE	£1.76
74121	£0.32	CD4049AE	£0.67
MM5314N	£4.77	TBA120	£1.24
SFE 6 mA (6 MHz Filter)			£0.90
I/C EXTRACTOR	£0.55	NE555V	£0.65
I/C INSERTER	£1.40	2N3055	£0.54

Crystals for any requirement

PH 100 5-digit 30 MHz freq. counter £99.50

Above types are partial examples.

Write or phone for details.

7 p.m. to 9 p.m. phone Dover (0304) 812332

Stock List free on request.

Suba AERIALS

FM Aerials

The Fuba UKa Stereo range of aerials provide complete coverage of high quality and high performance FM aerials. The Fuba UKa Stereo 8 is famous for really good long distance reception.



UKa Stereo 8

UHF TV Aerials

The famous Fuba XC 3 range of UHF TV aerials, and the unique AKV 450 "Active Capsule" amplifier which converts the passive aerial to an active one, will often provide out of area TV channels.



XC391

The unique Fuba *swing* indoor active FM aerial gives a level of performance not previously obtainable with indoor aerials.



*Full set of leaflets sent on receipt of large SAE with 9p stamp. Please mark envelope Cat. E. Prices will be included.

SPECIAL OFFERS for a limited period only.

Stolle Automatic aerial rotator with control unit at £39.80 including VAT and 15% discount. Carr free.

Exa UKW 2 FM aerial 2 elements; anodised type finish, £4.85 including VAT, carr and 20% discount.

5 Way rotator control cable, 20 metre length £4.00 including VAT and carriage.

Teldis 2 stage ultra broadband mast head amplifier and mains power supply unit, £13.70 including VAT and carriage and approx. 25% discount.

All offers apply for 4 weeks from date of publication. Please refer to this advertisement when ordering.



All products available from us CWO, Access or Barclaycard.

Audio Workshops Ltd

29 HIGH STREET, ROBERTSBRIDGE, SUSSEX, TEL. ROBERTSBRIDGE 880588 (STD 0580)

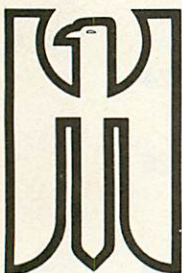

Phoenix Electronics (Solent) Limited

46 OSBORNE ROAD,
SOUTHSEA, PORTSMOUTH, HANTS.
CALLERS AT OUR SHOP WELCOME

Components and tools supplied guaranteed from franchise agreements. Member of AFDEC - the franchised component distributors association. Our catalogue sent for 20p including postage. All prices include VAT. Carriage is 20p extra on each order - minimum value £1

TTL - 93 TYPES AVAILABLE

7400	£ 0.17
7401,2,3,4,5,10	£ 0.21
7413,70,74	£ 0.33
7441,2,91	£ 0.95
7481,2,151,157	£ 1.35
7490	£ 0.75
7492,3	£ 0.89
74121	£ 0.59
74190,1	£ 2.20
74192,3	£ 1.99

LINEAR CIRCUITS

301A,307,709,741	£ 0.39
723 regulator	£ 0.49
537,558 dual	£ 0.59
747 dual	£ 0.69
555 timer	£ 0.85
309K regulator	£ 1.50

DTL - 11 TYPES AVAILABLE

Gates from	£ 0.29
Flip-flops from	£ 0.39

TRANSISTORS

BC107,8,9	£ 0.11
BC177,8,9	£ 0.15
BC182L,3L,4L	£ 0.09
BC204,5,6	£ 0.14
BC207,8,9	£ 0.09
BC212L,3L,4L	£ 0.10
BDY56	£ 1.72
BD135,6	£ 0.37
2N2219,20,21,22	£ 0.22
2N2904,5,6,7	£ 0.24
2N3442,BDY53	£ 0.88

DIODES

AA143,4,0A200	£ 0.08
1N914,6,4148,9	£ 0.06
1N4001-7	£ 0.07-£ 0.13
1N5402-6	£ 0.17-£ 0.21
ZENERS 5%	
½ Watt 3.3-15V	£ 0.11
1 Watt 4.7-24V	£ 0.22
10 Watt 8.2-24V	£ 0.83
BRIDGES 1-AMP P.C.	
W005 50V	£ 0.27
W08 800V	£ 0.40

RESISTORS ¼ WATT

Metal film 2% 30R-300K

CAPACITORS

Aluminium electrolyc, Polyester, Ceramic disc, Tantalum

CONNECTORS, CLIPS, KNOBS, LAMP HOLDERS, SWITCHES, FUSE HOLDERS, FUSE LINKS

All available in a wide range of sizes and designs

SOLDERING EQUIPMENT

Weller 'Marksman'	£ 3.02
Adcola 'Invader'	£ 3.11
Weller 'Expert' Gun	£ 7.84
'marksman' Stand	£ 2.18
'invader' Stand	£ 1.86
R500 Desolder Iron	£ 11.60

SOLDER AND DESOLDERING BRAID AVAILABLE.
WIDE RANGE OF SOLDERING ACCESSORIES

INTRODUCTORY OFFER TO ELEKTOR READERS SPECIAL VALUE BARGAIN PACK INCLUDING:

Small signal transistors - Triacs - Plastic power transistors - Diodes - HV rectifiers - Zeners. At least 50 pieces of discrete semiconductors. Integrated circuits - TTL and linear. Panel hardware selection including: Knobs - Jacks - Connectors - Fuses - Aluminium electrolytic, ceramic and film capacitors.

Total value at least £10 - sent with our new catalogue at an inclusive price of £3, post free.

Join the Digital Revolution

Teach yourself the latest techniques of digital electronics

Computers and calculators are only the beginning of the digital revolution in electronics. Telephones, wristwatches, TV, automobile instrumentation — these will be just some of the application areas in the next few years.

Are you prepared to cope with these developments?

This four volume course — each volume measuring 11 3/4" x 8 1/2" and containing 48 pages — guides you step-by-step with hundreds of diagrams and questions through number systems, Boolean algebra, truth tables, de Morgan's theorem, flipflops, registers, counters and adders. All from first principles. The only initial ability assumed is simple arithmetic.

At the end of the course you will have broadened your horizons, career prospects and your fundamental understanding of the changing world around you.

Digital Computer Logic and Electronics

A Self-instructional Course

C.P.Gane MA (Cantab)
A.W.Unwin BA (Cantab)

Book 1 Basic computer logic

Book 2 Logical circuit elements

Book 3 Designing circuits to carry out logical functions

Book 4 Flipflops and registers

Design of Digital Systems

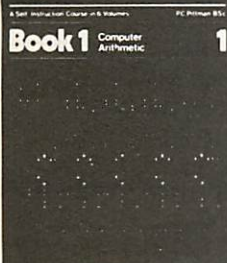

Also available — a more advanced course in 6 volumes:

1. Computer Arithmetic
2. Boolean Logic
3. Arithmetic Circuits
4. Memories & Counters
5. Calculator Design
6. Computer Architecture

Offer Order this together with Digital Computer Logic & Electronics for the bargain price of £ 9.70, plus 80 p p & p

£6.20 plus 80 p p & p.

Design of Digital Systems contains over twice as much information in each volume as the simpler course. Digital Computer Logic and Electronics. All the information in the simpler course is covered as part of the first volumes of Design of Digital Systems which, as you can see from its contents, also covers many more advanced topics.

**Designer
Manager
Enthusiast
Scientist
Engineer
Student**

These courses were written so that you could teach yourself the theory and application of digital logic. Learning by self-instruction has the advantages of being quicker and more thorough than classroom learning. You work at your own speed and must respond by answering questions on each new piece of information before proceeding to the next.

Guarantee — no risk to you

If you are not entirely satisfied with Digital Computer Logic and Electronics or Design of Digital Systems, you may return them to us and your money will be refunded in full, no questions asked.

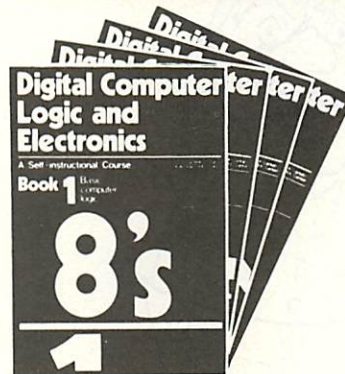

£4.20

plus 80 p packing and surface post anywhere in the world

Quantity discounts available on request.

Payment may be made in foreign currencies.

VAT zero rated.

To: Cambridge Learning Enterprises,
FREEPOST, St. Ives, Huntingdon, Cambs PE17 4BR

E14

- * Please send me set(s) of Digital Computer Logic & Electronics at £ 5.00 each, p & p included.
- * or set(s) of Design of Digital Systems at £ 7.00 each, p & p included.
- * or combined set(s) at £ 10.50 each, p & p included.

Name

Address

.....

* delete as applicable

No need to use a stamp — just print FREEPOST on the envelope.

I wouldn't
give
a dime
for an
elektor
circuit



You don't have to

on average they cost about
half a dime (2 p) each!

JPS
associates

HIGH QUALITY PROFESSIONAL AUDIO MODULES

Over the years there has been a growing demand for high quality audio power amplifier modules. At last and never before has such quality been offered at such a reasonable price.

All our modules at JPS are fitted with full output protection, and have a super High Stability Intergrated Circuit front end containing within itself no less than twenty transistors.

All JPS products carry a two year guarantee.

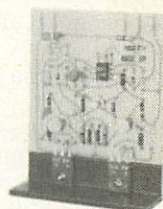
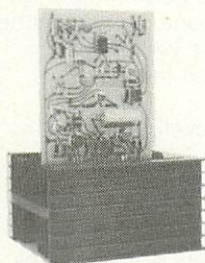

POWER OUTPUT: 170 W R.M.S. **150**

FREQUENCY RESPONSE:

D.C. - 21kHz - 0.2dB

POWER BANDWIDTH:

D.C. - 20kHz - 0.2dB

SLEWING RATE:

8.4V per microsecond

T.H.D.: .03%

INPUT SENSITIVITY:*

0dB (0.775V) 150 W

INPUT IMPEDANCE:* 47k

HUM and NOISE:

>100dB below 150 Watts

DAMPING FACTOR:

>200 to 1kHz

POWER REQUIREMENTS:

±55V D.C.

PRICE: £32.02 (inc. VAT)

POWER OUTPUT: 65 W R.M.S. **50**

FREQUENCY RESPONSE:

D.C. 21kHz 0.2 dB

POWER BANDWIDTH:

D.C. 20kHz 0.2 dB

SLEWING RATE:

8.6 V per microsecond

T.H.D.: .03%

INPUT SENSITIVITY:*

0dB (0.775V) 50W 8 ohms

INPUT IMPEDANCE:* 47k

HUM and NOISE:

>100dB below 60W

DAMPING FACTOR:

>200 to 1kHz

POWER REQUIREMENTS:

±35V D.C.

PRICE: £19.20 (inc. VAT)

*At a small extra charge, these parameters may be changed to order. Impedance: Max 250K - Sensitivity: 100mV RMS

As both modules are totally D.C. coupled, they may also be ordered as D.C. amplifiers, the Power Response then being -0dB + 0.5dB - D.C. to 20 kHz

POWER SUPPLIES below are available upon request:-

PS50 (Drives single 50 Watts) £11.07 PS150/1 (Drives single 150 Watts) £18.15

PS502 (Drives dual 50 Watts) £14.57 PS150/2 (Drives dual 150 Watts) £23.00

N.B. It is not recommended that the D.C. Modules are used for audio installations as extreme low frequencies damage loudspeaker systems.

Please send me further information

I herewith enclose Cheque/Postal Order for £..... made payable to JPS Associates.

For 150 watt modules @ £32.02 (inc. VAT)

For 50 watt modules @ £19.20 (inc. VAT)

Quantity Discounts upon request . . .

NAME

ADDRESS

..... Postal Code

All JPS Products carry a full Two Year Guarantee.

TELEPHONE 01-961 1274

JPS
associates

**BELMONT HOUSE
STEELE ROAD
PARK ROYAL
LONDON NW10 7AR**

B. BAMBER ELECTRONICS

DEPT E, 5 STATION ROAD, LITTLEPORT, CAMBS., CB61QE
Tel: ELY (0353) 860185 (2 lines) Tuesday to Saturday.

ALL ITEM + 8% VAT (UNLESS OTHERWISE MARKED)

BARGAIN OFFER MIXED COMPONENT PACKS, containing resistors, capacitors, switches, pots, etc., All New, (Random sample bag revealed approx. 700 items) £ 2.00 per pack, while stocks last.

TRANSISTOR HEATSINKS, to take 2 x TO 18 transistors, screw in clamps, block size 1 1/2 x 1/2 in, with holes for mounting 3 for 50p

MINIATURE 2 PIN PLUGS & SOCKETS (Fit into 1/4" hole, pins enclosed, with covers for chassis mounting, or can be used for in-line connectors). Bargain pack of 3 plugs + 3 sockets + covers 50p

PROGRAMMERS (Magnetic Devices) Contain 9 microswitches (suitable for mains operation) with 9 rotating cams, all individually adjustable, ideal for switching disco lights, displays, etc., or industrial machine programming. (Need slow motion motor to drive cams, not supplied) 9 switch version £1.50

HEAVY DUTY HEATSINK BLOCKS, undrilled, base area 2 1/4" x 2", with 5 fins, total height 2 1/4" 50p each

9V RELAYS, Continental type, 2 pole change over 35p

RUBBER MAGNETS 1/2" square, with mounting hole 20 for 30p

SPERRY 7-SEGMENT P.G.D. DISPLAYS, digit height 0.3 in red, with decimal points, 150V to 200V (nominal 180V) operation. These are high-volt industrial type and therefore brighter than normal displays. All brand new, AT THE BARGAIN PRICE OF 50p PER DIGIT.

Type 332 (two digits in one mount) £1.00 each
Type 333 (three digits on one mount) £1.50
(Sorry, no single digit available). Data Supplied.

BSX20 Transistors	3 for 50p
BC108 (metal can)	4 for 50p
PBC108 (plastic BC108)	5 for 50p
OC200 Transistors	6 for 50p
BSY95A Transistors	6 for 50p
BFY51 Transistors	4 for 60p
BCY72 Transistors	4 for 50p
PNP audio type TO 5 Transistors	12 for 25p

Telephone Type earpiece insert	50p
1 1/4" Polythene chassis mounting fuseholders	6 for 30p
LES Lamps, 24V 1.2W	10 for 40p
Mullard Tubular ceramic trimmers. 1-18pf	6 for 50p
I.C.'s, some coded, 14 DIL type, untested mixed	20 for 25p
Miniature slider switches, 2 pole 2 way 5 for 50p	

DIECAST BOXES
The range of aluminium alloy diecast boxes has the unique feature of internal slots for dividing parts, e.g. screens, printed circuits boards etc. For use as screened sub-assemblies, as rigid chassis, as junction boxes, for test sets and for complete equipment.

In the following sizes:

* 4.3" x 2.3" x 1.2" approx.	85p
4.8" x 2.8" x 1.5" approx.	75p
4.8" x 3.8" x 1" approx.	85p
4.8" x 3.8" x 2" approx.	£1.00
6.8" x 4.8" x 2" approx.	£1.45
4.8" x 3.8" x 3" approx.	£1.55
6.8" x 4.8" x 4" approx.	£2.25
8.6" x 5.8" x 2" approx.	£1.85
10.6" x 6.8" x 2" approx.	£2.25

* NO INTERNAL SLOTS
PLUGS & SOCKETS
T.V. PLUGS (Metal Type) . . . 5 for 50p
T.V. SOCKETS (Metal Type) . 4 for 50p
T.V. LINE CONNECTORS (Back-to-back sockets) . . . 4 for 50p
DIN 3-pin LINE SOCKETS . . . 15p each
DIN 3-pin PLUGS

BARGAIN PACKS
MIXED DIELECTRIC CAPACITORS (Approx 100) £1.50

ELECTROLYTICS (LOW VOLTAGE TYPES) £1.50 (Approx 100)

ELECTROLYTICS (HIGH VOLTAGE TYPES) £1.50 (Approx 50)

RESISTORS (MIXED WATTAGES) MIXED VALUES £1.00

PLEASE ADD 12.5% VAT TO ALL RESISTORS & CAPACITOR PACKS

HIGH QUALITY SPEAKERS, 8 1/2" x 6" elliptical, only 2" deep, inverse magnet, 4 ohms, rated up to 10 W, £ 1.50 each, or 2 for £ 2.75 (qty. discount available + 12.5 VAT.

WELLER SOLDERING IRONS

WELLER SOLDERING IRONS EXPERT Built-in-spotlight illuminates work Pistol grip with fingertip trigger. High efficiency copper soldering tip.

EXPERT SOLDER GUN £6.80 + VAT (54p)

EXPERT SOLDER GUN KIT (SPARE BITS, CASE, ETC.) £9.80 + VAT (78p)

SPARE BITS PAIR, 26p + VAT (2p)

MARKSMAN SOLDERING IRON Unbreakable heat-resistant handle. Stainless steel barrel. Special steel heating elements with Mica insulation bedded in ceramic.

SP15D 15W £2.52 + VAT (20p)
SP25D 25W £2.52 + VAT (20p)
SP25D 25W + BITS etc, KIT £3.12 + VAT (25p)

BENCH STAND with spring for MARKSMAN IRONS £1.80 + VAT (14p)
Spare sponges, as for TC P1.

SPARE BITS
MT8 for 15W 42p + VAT (3p)
MT4 for 25W 35p + VAT (3p)

TC P1 TEMPERATURE CONTROLLED IRON

Most versatile soldering tool yet designed. 48W pencil out-performs uncontrolled irons several times its weight and consumption. Temperature controlled iron & PSU. £18.43 + VAT (£1.47)

SPARE TIPS
Type CC SINGLE FLAT, Type K DOUBLE FLAT FINE TIP. 90p each + VAT (8p)

ALL SPARES AVAILABLE.

MULTICORE SOLDER
Size 5 SAVBIT 18swg in alloy dispenser 32p + VAT (3p)
Size C1SAV18 SAVBIT 18 swg 56p + VAT (4p)
Size 12 SAVBIT 18swg on plastic reel £1.80 + VAT (15p)

MINIATURE PLIERS
HIGH QUALITY "CRESCENT" MADE IN USA £4.35 + VAT (35p)

SIDE CUTTERS
HIGH QUALITY "CRESCENT" MADE IN USA £5.45 + VAT (44p)

SOLDER SUCKERS (HIGH QUALITY, PLUNGER TYPE) STANDARD £4.50 + VAT (36p)
WITH SKIRT £4.95 + VAT (40p)
Spare nozzles (PTFE) 60p each + VAT (5p)

RUBBER BULB TYPE
A handy inexpensive tool for the quick removal of solder. Small, lightweight and easy to use. Teflon tippets easily changed or replaced.

No. 881 Complete Tool. £1.20 + VAT (10p)
No. 8810 Nozzle only 50p + VAT (4p)

Terms of Business: CASH WITH ORDER. MINIMUM ORDER £1.00. ALL PRICES INCLUDE POST & PACKING (UK ONLY).

SAE with ALL ENQUIRIES Please. PLEASE ADD VAT AS SHOWN. ALL GOODS IN STOCK DESPATCHED BY RETURN.

QUARTZ CRYSTAL UNITS from

- ★ 1.0-60.0MHz
- ★ FAST DELIVERY
- ★ HIGH STABILITY
- ★ TO DEF 5271-A

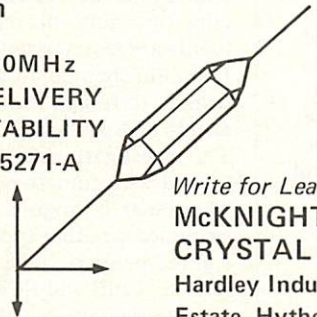

Write for Leaflet AT-1
McKNIGHT CRYSTAL Co. Ltd.
Hardley Industrial Estate, Hythe, Southampton SO4 6ZY (248)

TEL. HYTHE 848961
STD CODE 0703

say you saw it in elektor and don't forget.....

Printed circuit boards are available for many projects published in Elektor. Refer to the 'eps print service' list in this issue and quote ref. no. when ordering.

The Semicon International Transistor Index

6th EDITION (1975/6)

Easy alpha-numeric reference to the ratings and characteristics of some 24,000 transistors of international origin. European, U.S.A., Japanese. Essential guide for all Engineers, Technicians, and Buyers. Over 450 pages of basic information. By far the best manual of its kind available anywhere to-day.

- * EXTENSIVE SUBSTITUTION GUIDE
- * CV & BS DEVICES & EQUIVALENTS
- * TERMINATION DRAWINGS
- * ALTERNATIVE SOURCES OF SUPPLY

Remit with order price. UK only. **£9.60** Elsewhere £10.90 Surface mailing.

Please send copies of the Semicon Transistor Index, 6th Ed. to:

Name
Address

I enclose cheque/postal orders for £

My Access/Barclay/Interbank Card No. is

Refund if not satisfied and book is returned within 14 days.
Semicon Indexes Ltd. 2 Denmark St. Wokingham. Berks. RG11 2BB
TEL: WOKINGHAM (0734) 786161

SELEKTOR SELEKTOR SELEKTOR SELEKTOR SELEKTOR

Build a Digital Watch — the easy way

For those who want to make a digital watch but are deterred by the degree of miniaturisation involved, a range of preassembled watch modules is available from Litronix. Prices have fallen so rapidly in recent months that it is now cheaper to buy one of these modules than to purchase the individual components for a watch, and it is only necessary to fit the module into a case and install batteries to obtain a fully-working watch.

The timekeeping function is integrated into a single ion-implanted CMOS chip and the display drivers are contained in two silicon bipolar IC's. These, together with the LED display, 32.768 kHz

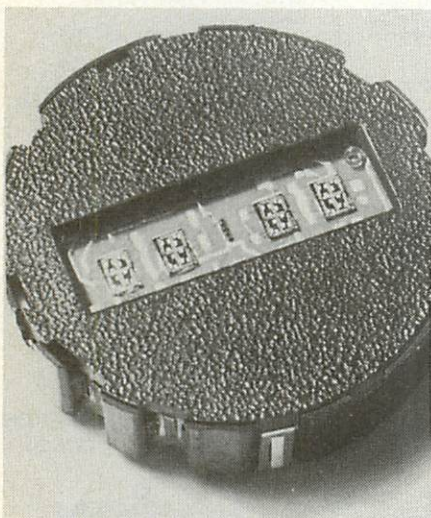

crystal, capacitors and resistors, are mounted on a ceramic substrate using hybrid assembly techniques. This in turn is mounted in a high impact plastic frame to provide mechanical protection for the module. Gold-plated switch contacts are provided around the periphery of the module to activate the display and timesetting functions. The module is powered by two RAY-0-VAC RW-44 silver oxide batteries (or equivalent) and battery life is said to be one year with up to twenty interrogations per day.

The cheaper version of the watch module, the LWM-6531, has an hours and minutes display with a flashing colon for seconds. One-off price is around £ 15.

The more expensive version, the LWM6560, retails for about £ 18 and displays hours and minutes, seconds, day-of-week and date. It also incorporates a light sensor to adjust the display brightness to suit ambient light and thus extend battery life.

*Litronix House,
593 Hitchin Road, Stopsley,
Luton, Bedfordshire.*

Vegetable Growing by Computer

Researches in Naaldwijk, Holland, wish to know exactly how fast tomatoes ripen and how well cucumbers, for example, grow in greenhouse conditions. Assistance of a computer has been called on at the research and experimental institute for the cultivation of fruit and vegetables. At the present time this is the largest research project of its kind in the world. A Siemens 330 process computer monitors and controls the environmental conditions in 24 growing compartments within the large greenhouse.

In addition to the central processing unit with a main memory of 64 K words (16 bits each), the computer system comprises a series of data input/output devices. These include, process interfacing devices for connection to the measuring and control systems of the individual climatic chambers. The task of this process periphery is to collect 800 analog and 80 digital signals, while also handling 450 digital output signals. Twenty-six analog signals are recorded in each of the 24 climatic chambers (each 56 m² in area). These include temperature values for the air and soil, relative humidity, CO₂ concentration of the air, temperature of the water in the heating system, signals indicating window positions and the various values for the irrigation and drainage systems and the heating system. Sixteen digital outputs in each climatic chamber control the motors of the valve drives and window adjusters. In addition, the weather station parameters can also be included in the calculations and control operations.

The signals issued from each sensor are scanned once every minute. The process computer calculates the manipulated variables and the setpoints of the secondary analog backup controllers by direct digital control so that a smooth changeover to analog control is possible if required.

Every day an estimated one million

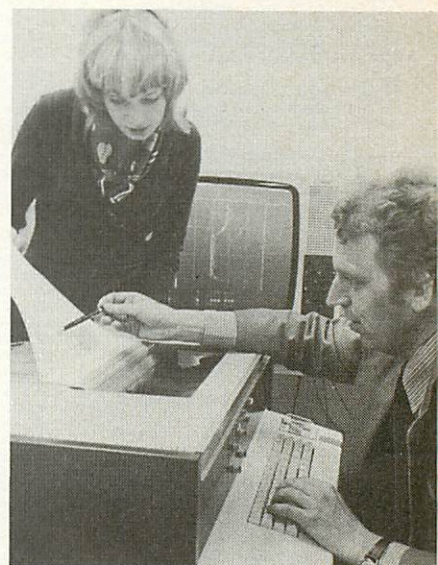

measured values, signals and commands are exchanged between the process computer and its peripherals. All relevant data can be logged in tabular form, using the typewriter. In addition, the case history of 256 values over the the previous 96 hours can be graphically represented on the colour curve display station.

The aim of the investigations in Naaldwijk is not only to research the optimum conditions for growing fruit and vegetables but also to determine the climatic conditions under which the plants are least susceptible to diseases. It should then be possible, to a certain degree, to forego the use of chemical agents and pesticides.

The investigations are at present concerned with tomatoes and cucumbers. The research program is later to be extended to other types of vegetable, e.g. red peppers, aubergines, beans and lettuce. Fruit and flowers are also to be investigated at a later date. At present, tomatoes grown in Dutch greenhouses have annual production value of approximately £ 9.6 million.

*Siemens AG
Zentralstelle für Information
Postfach 3240, D-8520 Erlangen 2
Federal Republic of Germany*

'Noiseless' Discs and tapes

A new process which completely eliminates surface and background noise from disc recordings and captures for the first time the full dynamic range of the music is announced by dbx, Incorporated, manufacturer of noise reduction systems for the professional studio and the audiophile.

The process permits commercial discs as played in the home to equal the performance quality of studio master tapes. This is accomplished by electronically compressing the recorded

SELEKTOR SELEKTOR SELEKTOR SELEKTOR SELEKTOR

signal by a factor of 2:1 at the time the master disc is cut, and expanding the signal by a complementary factor of 1:2 at the point of playback. If a dbx encoded master tape is used, full dynamic range and freedom from noise will be realized upon playback. Master tapes produced with other types of noise reduction systems, or with no noise at all, may be used and the played back disc will sound equal to the master tape. Ordinary discs are limited to a dynamic range of some 60 dB, whereas the dbx encoded disc has a range well in excess of 100 dB.

The dbx process compresses the dynamic range of the music to a 'dynamic range envelope' which fits conveniently within the inherent limitations of the record medium, then expands the music to its full original dynamics at the point of playback.

This compression and subsequent expansion reduces record surface noise and other unwanted background noise to inaudibility, so that when the musical program stops, no sound of any kind is heard from the playback system.

The complete absence of background noise also makes the quiet portions of the music easier to hear, and the definition of individual voices and instruments in ensemble music is dramatically improved.

A significant advantage of the dbx disc encoding process is that it does not obsolete any existing manufacturing technique or equipment presently in use in the recording industry, nor does it increase actual product cost in any way. On the contrary, dbx encoding offers numerous opportunities for reducing the cost of recorded music without compromising quality. For example, with dbx encoding, record grooves may be placed closer together, increasing the amount of music on a record by up to 30%.

Electronic expansion circuitry, similar in cost and complexity to Dolby B and quad matrices, is required at the point of playback to properly decode the dbx compressed signal. The decoder circuitry is now available to audio equipment manufacturers for inclusion in consumer audio components and systems on a license basis. Also, many audio component dealers are now selling the 120 consumer series of compressor/expander noise reduction systems which have disc decoding circuitry built in.

The 120 series uses the same 2:1 linear decibel compression/expansion principle used in dbx professional studio equipment, but the sensing circuits have been optimized to best complement the bandwidth requirements of consumer grade reel-to-reel, cassette and cartridge tape recorders. The 120 series is not compatible with dbx professional format tape noise reduction systems

used in recording studios.

The new systems allow consumer grade recorders with signal-to-noise ratios as low as 45 to 50 dB to produce full dynamic range tapes which are audibly free from tape hiss and background noise. In excess of 30 dB noise reduction can be realized with the 120 system, along with 10 dB headroom improvement which reduces the likelihood of tape saturation.

The 120 noise reduction format is also used by record manufacturers for processing of dbx encoded records, and a 120 family decoding device is required for playing the dbx encoded discs.

Two models are initially available in the 120 family of noise reduction units.

Model 122 is a two-channel record or playback unit. That is, it will either record or playback, and is switched from one function to the other.

Model 124 is a four-channel record or playback unit suitable for the full range of quadraphonic activities, and having the added feature that when used in a two-channel system it can record and playback at the same time, permitting the recordist to monitor the decoded or normalized signal during recording.

Commercial record labels currently releasing stereo discs in dbx encoded format include Klavier and Creative World, and negotiations are in progress with a number of other labels to release material in dbx encoded format. Both Models 122 and 124 will decode presently available dbx encoded stereo discs. dbx disc encoding is equally applicable to the production of quadraphonic releases as well, regardless of whether they are produced in discrete (4-4-4) or matrixed (4-2-4) format.

*dbx Incorporated,
296 Newton Street,
Waltham, Massachusetts 02154.*

Ion beams etch chip structures

New etching process for superfine structures on semiconductor chips.

Semiconductor chip structures have become unbelievably small, and this trend will continue. The wavelength of the light beam, used to create component contours on chips using the photomasking processes, is nowadays often not short enough. This is why electron beams with their markedly shorter wavelengths must be used. Such beams are capable of producing structure spacings of $1 \mu\text{m}$ and less. However, it is then necessary to use a different method to create the structures, which are defined by a photo-mask. This is because the chemical

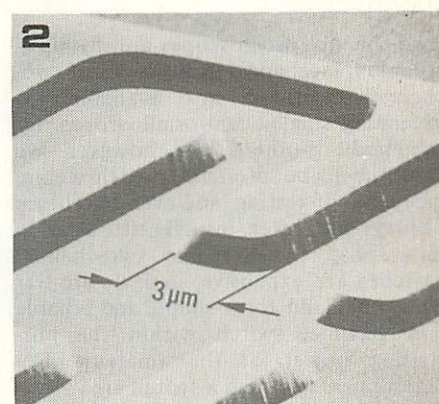
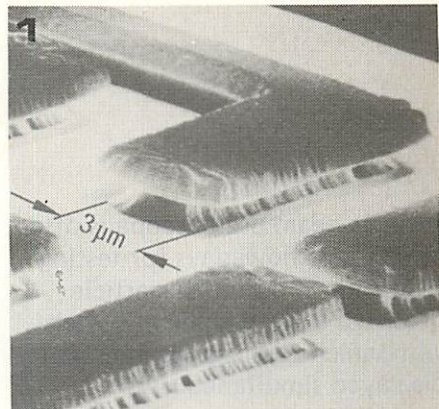

Comparison of chemical and ion beam etching. The chemically etched structures in the left-hand photo are characterized by undercutting below the photo-mask and the curved side walls. The ion-etched structures in the right-hand photo are characterized by smooth, straight side walls.

Siemens Photo

etching processes that are being used now have an undercutting effect — whereby the side walls of the structures are washed away from underneath. This just cannot be tolerated in the case of superfine structures in the submicrometer range. A process is at the present time being worked on at the Siemens laboratories, this process uses an ion beam, working mechanically like a sand blasting jet. It cleanly cuts out even the very finest chip structures.

The fast argon ions required for this job are produced in a plasma chamber, then are directed onto the photoresisted silicon chips. The structures are transferred practically without change in dimensions independently of the resist adhesion. The particular advantage of this process is that the side walls of the chip structures are smooth in contrast to chemical etching, and the angle of the side walls has a uniform value of around 65° (see photo).

*Siemens AG
Zentralstelle für Information
Postfach 3240, D-8520 Erlangen 2
West Germany*

Dipl. Ing. H. Weidner

channel quadrupler

A single-beam oscilloscope is often insufficient nowadays for testing electronic circuits. This article describes a multi-channel switch with which four signals may be displayed simultaneously.

Two-channel oscilloscopes are, by now, commonplace, and various types of two-channel switches are available for extending single-beam oscilloscopes. By somebody-or-others law, however, we continue to build circuits which we are incapable of testing, and even two-beam displays are often insufficient. Bear in mind that the available two-channel switches are expensive, and we are left with a demand for a simple and reliable multi-channel switch within the purchasing power of the amateur. The requirements of such a switch are:

1. four channels;
2. unity gain and a facility for attenuation;
3. Y-position separately adjustable for each channel;
4. both chopped and alternating switching modes;
5. facility for selecting each channel separately.

This article describes a switch to meet these requirements, with the design being kept as simple as possible by starting off with a suitable integrated circuit.

A survey of ICs available on the market led to the selection of the HA2405 made by Harris. This consists of four operational amplifiers (opamps), only one of which is activated at any one time depending on the information at the two control inputs (pins 15 and 16). The outputs of the four opamps are internally connected to the common output amplifier, so that the output of the activated opamp is available at the common output point (pin 10). Otherwise, the IC behaves as expected for an opamp. The maximum output voltage

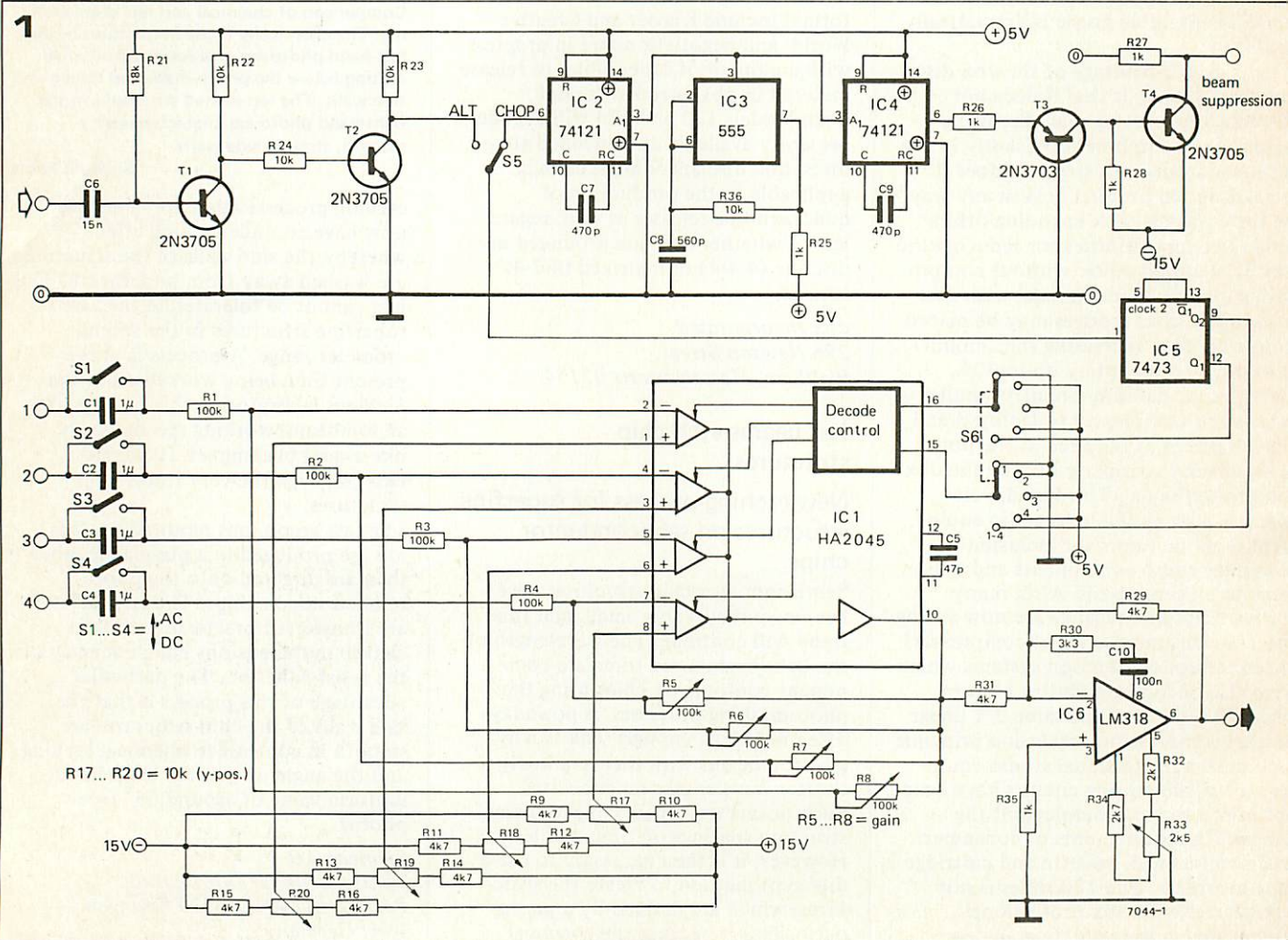

Figure 1. Circuit diagram of the four-channel switch.

Figure 2A. Pin connection diagram for the HA2405.

Figure 2B. Pin connection diagram for the LM318.

Figure 3. Front view of the (German!) prototype.

variation is ± 10 V, the gain and attenuation being adjustable in the usual way with feedback resistors.

The circuit

Figure 1 gives the circuit diagram of the switch. As can be seen, the four opamps in IC1 provide the central part of the circuit, with their gain and attenuation being controlled by the input resistors R1...R4 and the feedback resistors R5...R8. The gain of the first opamp is controlled by the ratio of R1 : R5 (similarly for the other opamps); the maximum gain in this case being unity (0 dB), and the attenuation being controlled by the variable resistors R5...R8. Calibration of the attenuation has not been included (since phase comparisons are usually of more interest) but it would be fairly simple to include calibration if required, either by fitting a calibration scale for the variable resistors, or by replacing them with multi-position switches between fixed resistors. The maximum input voltage should not exceed ± 10 V, which is sufficient for most applications, although the input voltage range could always be extended by using voltage-divider probes with an attenuation of 10 : 1.

The Y-position of the signals displayed on the screen is controlled by the potentiometers R17...R20 which control the voltage to the non-inverting inputs of the opamps. The values of the resistors in series with these potentiometers have been chosen to give a full-screen display on the oscilloscope with the input sensitivity set to 1 V/cm. Other values may be substituted if other ratios are required.

Since the HA2405 performs an inversion between input and output, IC6 has been included to invert the signal again so that the correct polarity is obtained at the output of the switch. Also included here is a feed-forward circuit R30, C10, which improves the slew rate.

Moving on to channel selection, this is achieved by the switch S6, through which digital information is supplied

2a

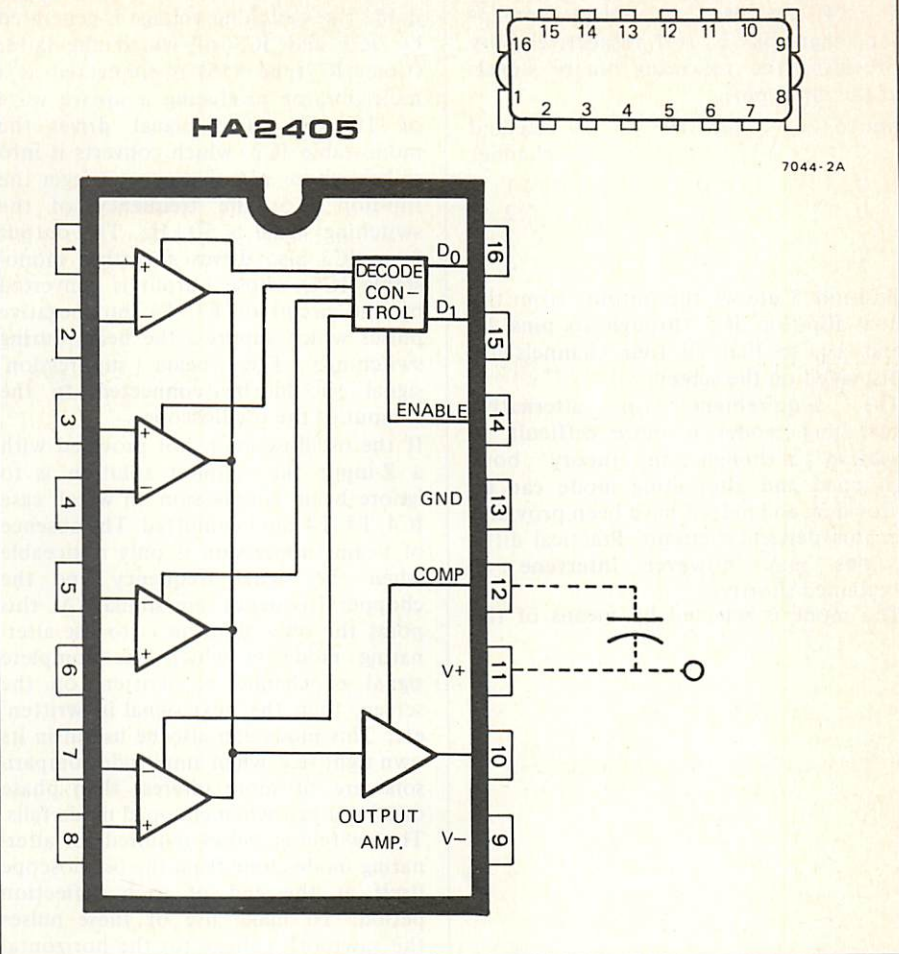

2b

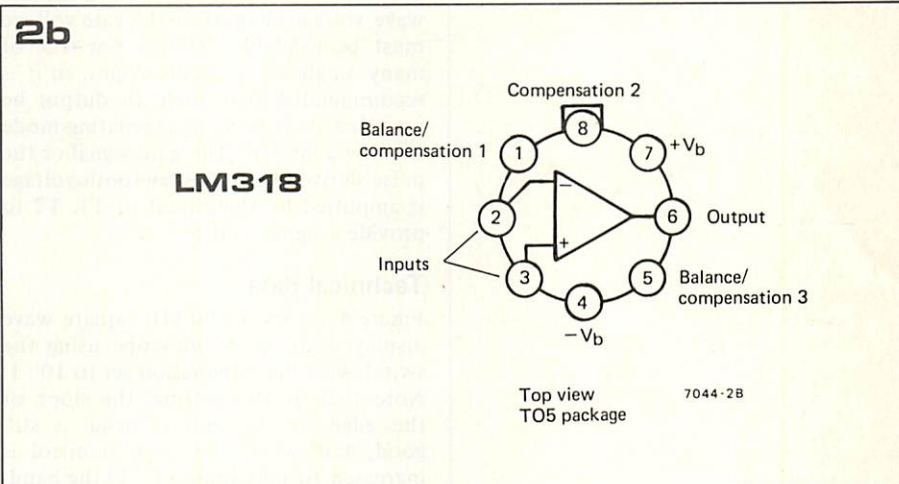

3

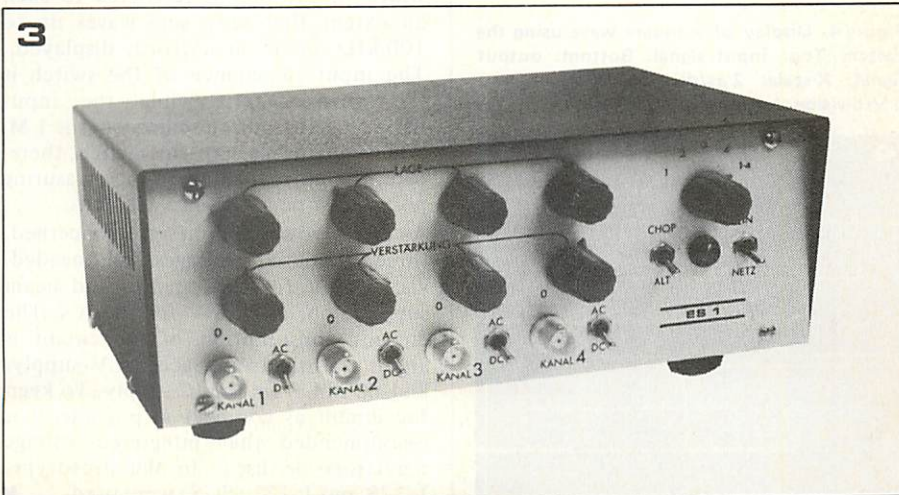

to the two controlling inputs. S6 is a five-position switch of which positions 1...4 are used to select opamps (i.e. channels) 1...4 respectively, by providing the following binary signals at the input pins:

pin 15	pin 16	selected channel
0	0	1
0	1	2
1	0	3
1	1	4

Position 5 allows the outputs from the dual flip-flop IC5 through to pins 15 and 16, so that all four channels are displayed on the screen.

The requirement for alternative switching modes is more difficult to achieve although in theory both chopped and alternating mode can be provided, and indeed have been provided in this particular circuit. Practical difficulties may however intervene as explained shortly.

The mode is selected by means of the

switch S5, which connects one of the two control sections to IC5. In chopped mode the switching voltage is generated by IC2 and IC3 of which the latter (timer IC type 555) is connected as a multivibrator producing a square wave of 100 kHz. This signal drives the monostable IC2, which converts it into spikes whose negative edges trigger the flip-flop IC5; the frequency of the switching signal is 50 kHz. The output from IC3 also drives a further monostable IC4, whose output is converted by the circuit of T3, T4 into negative pulses which suppress the beam during switching. The 'beam suppression' signal should be connected to the Z-input of the oscilloscope.

If the oscilloscope is not provided with a Z-input the simplest solution is to ignore beam suppression, in which case IC4, T3, T4 can be omitted. The absence of beam suppression is only noticeable when the signal frequency and the chopper frequency are similar. At this point the only solution is to use alternating mode in which one complete signal or channel is 'written' on the screen, then the next signal is 'written' etc. This mode can also be useful in its own right (e.g. when amplitude comparisons are of more interest than phase ones) not just when chopped mode fails. The switching pulses required for alternating mode come from the oscilloscope itself at the end of each deflection period. To make use of these pulses the sawtooth voltage for the horizontal deflection (if necessary via a square wave voltage shaper) or the gate voltage must be available. This is not true of many single-beam oscilloscopes, so it is recommended that such an output be provided if working in alternating mode is to be achieved. The gate signal or the pulse derived from the sawtooth voltage is amplified by the circuit of T1, T2 to provide a signal to IC5.

Technical data

Figure 4 shows a 100 kHz square wave displayed on an oscilloscope using the switch with the attenuation set to 10 : 1. Note that as this setting, the slope of the edge of the output signal is still good, but when the 'gain' control is increased to maximum (1 : 1) the bandwidth of the unit is restricted to such an extent that only sine waves up to 100 kHz can be satisfactorily displayed. The input impedance of the switch is less than 100 k, while the input impedance of most oscilloscopes is 1 M. When measuring with this switch, therefore, the extra loading on the measuring point must be taken into account.

As far as power supplies are concerned, three stabilised voltages are needed, viz: ± 15 V for the opamps and beam suppression, and +5 V for the ICs. The current consumption of the circuit is about 25 mA from each 15 V supply, and 60 mA from the IC supply. To keep the circuit as compact as possible, it is recommended that integrated voltage regulators be used. In the prototype, L 129 and L 131 (SGS) were used. \blacksquare

J. Hájek

measuring pencil

Here is a device to help with that of recurring requirement — an extra pair of hands. This measuring pencil can be used as a probe for inspecting voltages in addition to its conventional application of writing down the results.

The measuring pencil consists of a propelling pencil made of a synthetic resin. A flex is soldered to the push-button such that the propelling mechanism is unimpaired, and the other end of the flex is provided with a plug to fit the measuring instrument (e.g. a voltmeter). To use the pencil, connect the circuit to be tested to the earth terminal of the meter, and the pencil to the input socket. Using the pencil as a probe, the circuit voltages may now be measured at various points and the results written down with the same instrument.

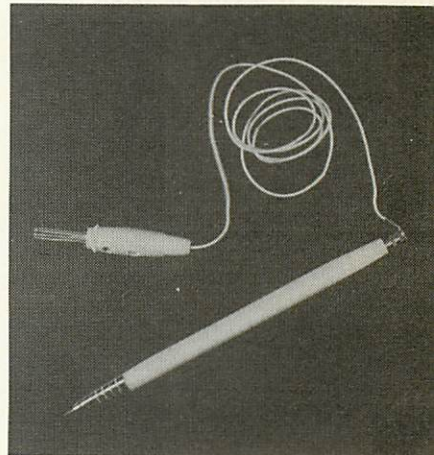

The measuring pencil is particularly suitable for circuits with low voltages (≤ 42 V AC or ≤ 60 V DC) as the insulation of the pencil is not then a problem. The contact resistance between the measuring point and the meter is less than 1 Ω in this design, and when used with modern high impedance equipment, the measuring error is negligible. \blacksquare

Figure 4. Display of a square wave using the switch. Top: input signal. Bottom: output signal. X-scale: 2 μ s/division. Y-scale: top: 2 V/division; bottom: 0.2 V/division.

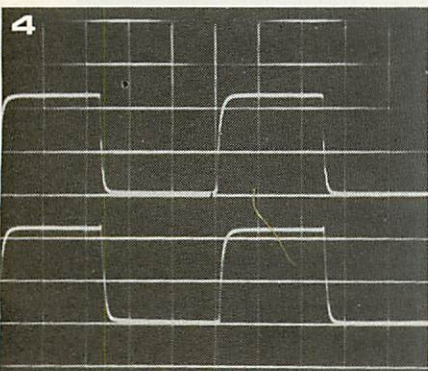

VHF FM reception

Owners of FM tuners may often wish to know what sort of signal level they can expect to receive in the locality in which they live. The simplest and most accurate method is to obtain a direct reading using a field strength meter, but of course very few people possess one of these instruments. The charts produced by the BBC of the service areas of their various transmitters provide a useful guide, but it is often possible with a sensitive receiver and good aerial to obtain a usable signal outside the service area. This article investigates the rules governing VHF propagation and shows how received signal strengths may be estimated with a few simple calculations.

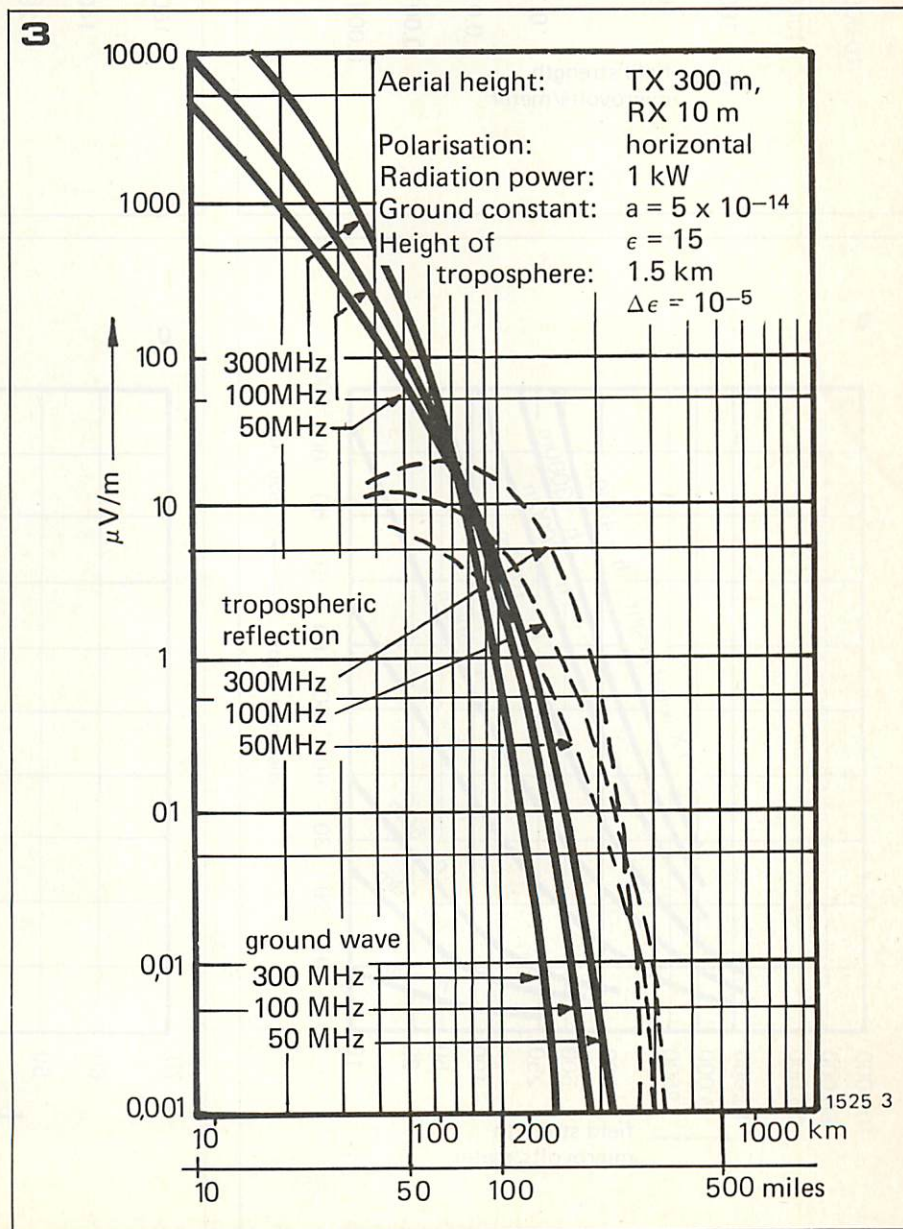
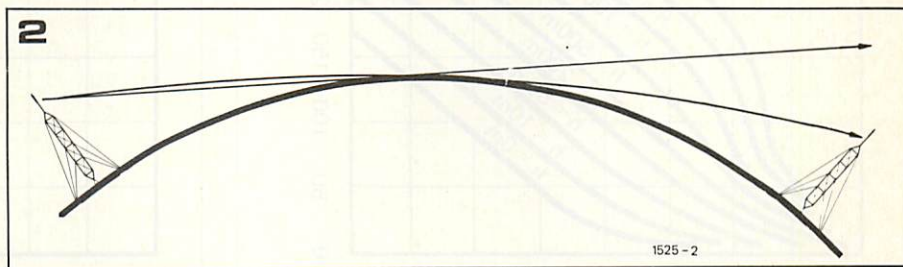
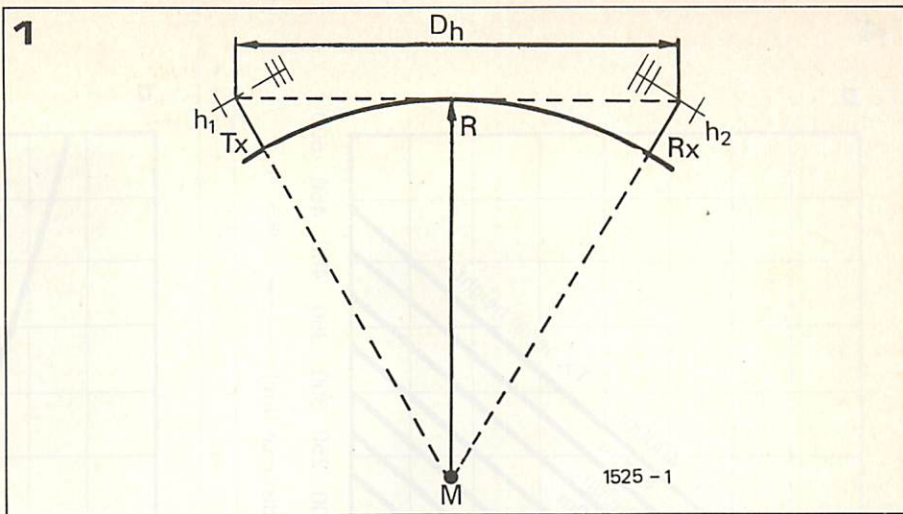
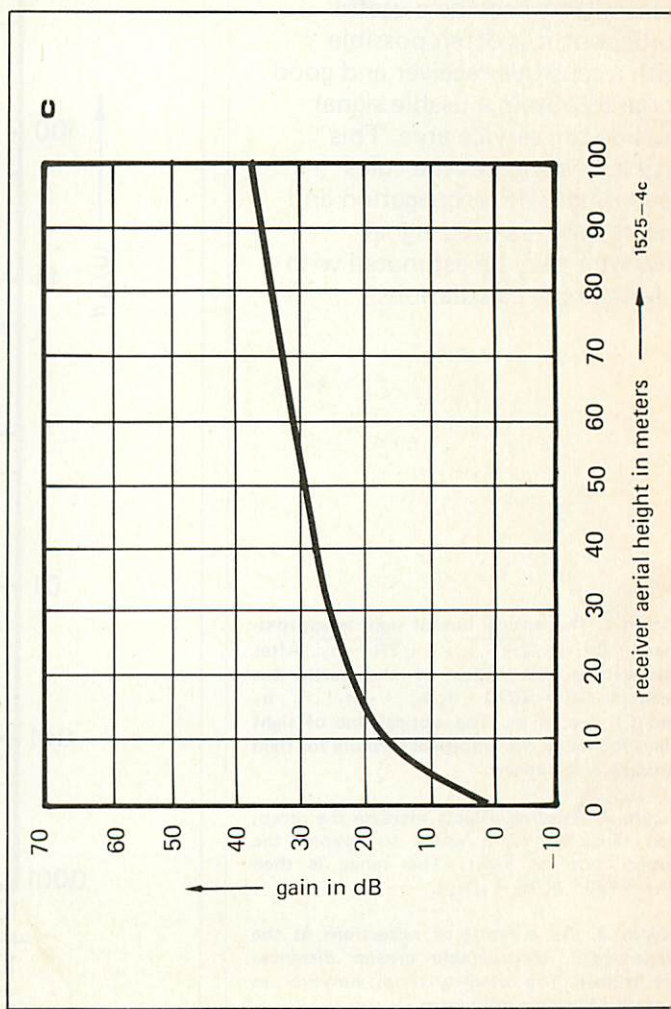
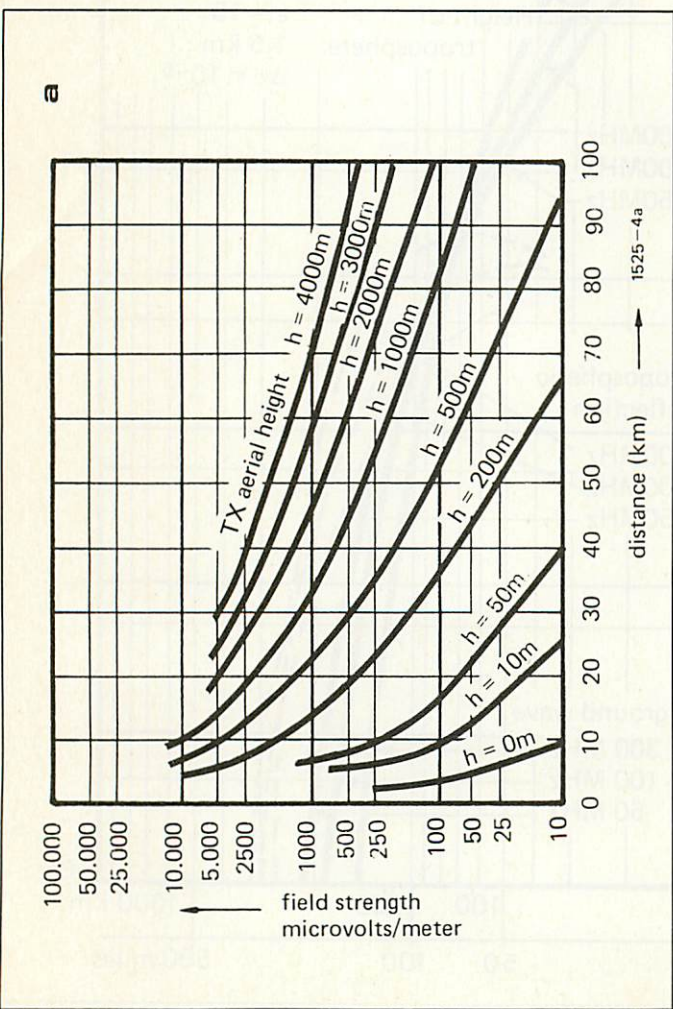
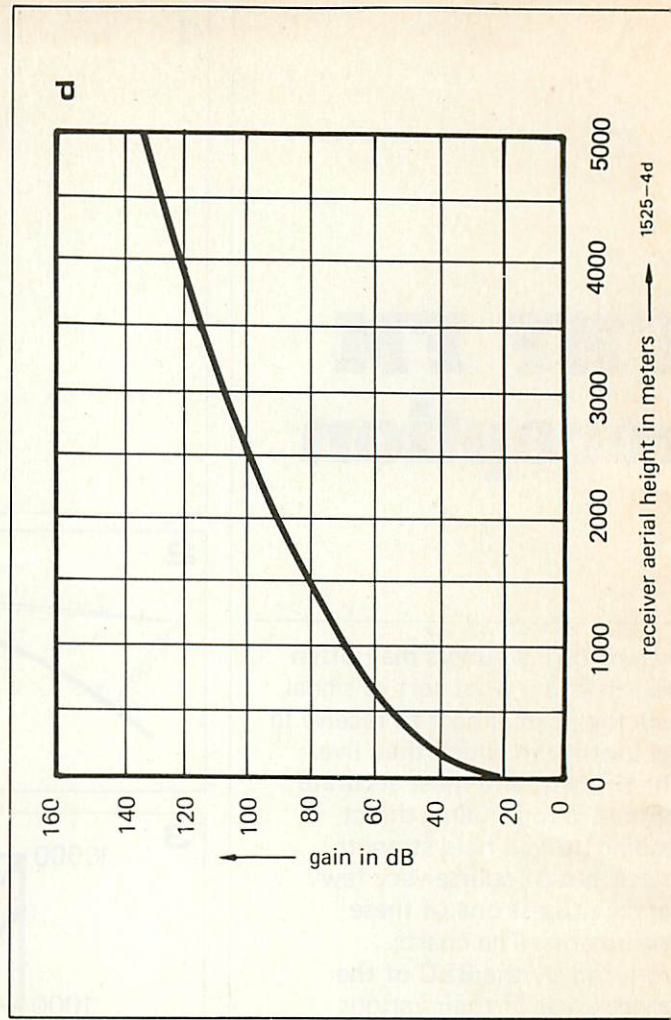
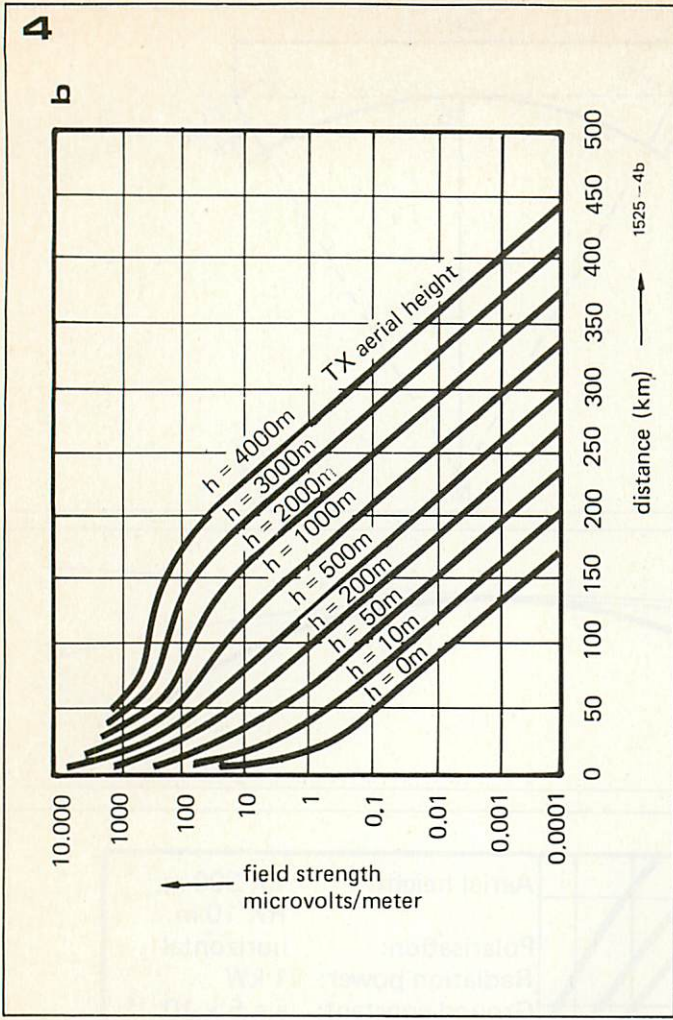

Figure 1. The optical line of sight is approximately $Dh = \sqrt{2R \cdot h_1} + \sqrt{2R \cdot h_2}$. After introducing the radius of the earth this becomes $Dh = 3570 \cdot (\sqrt{h_1} + \sqrt{h_2})$. h_1 , h_2 and Dh are in m. The optical line of sight plays a part in the empirical formula for field strength calculations.

Figure 2. Bending effects increase the reception range of radio waves to beyond the optical line of sight. The range is then $Dh = 4120 \cdot (\sqrt{h_1} + \sqrt{h_2})$.

Figure 3. As a result of reflections at the troposphere, considerably greater distances are bridged. The intensity varies, however, as a result of cosmic influences.



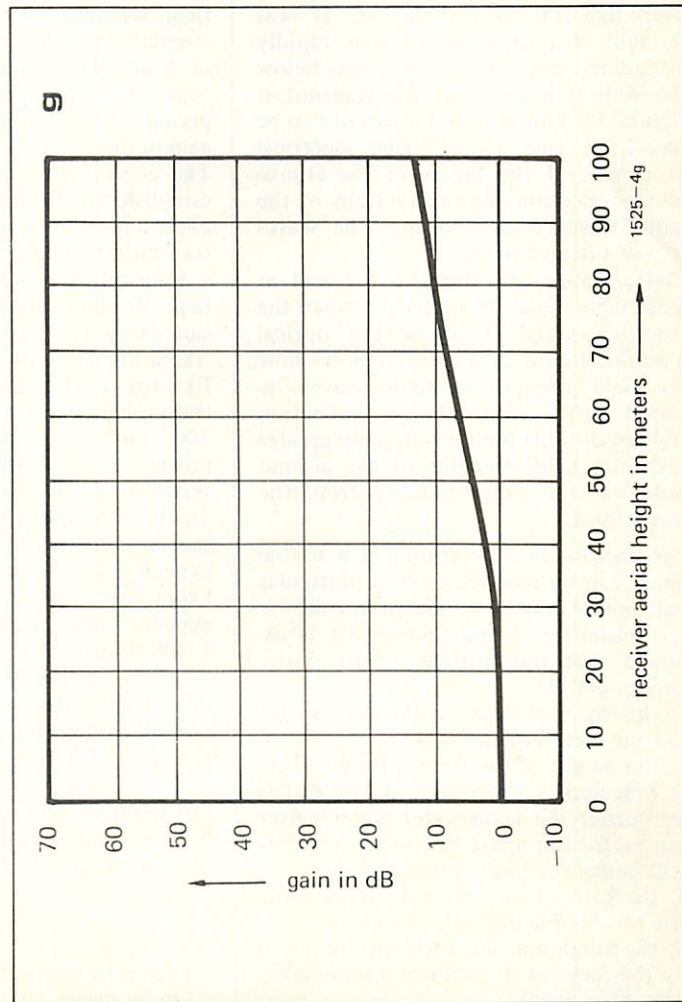
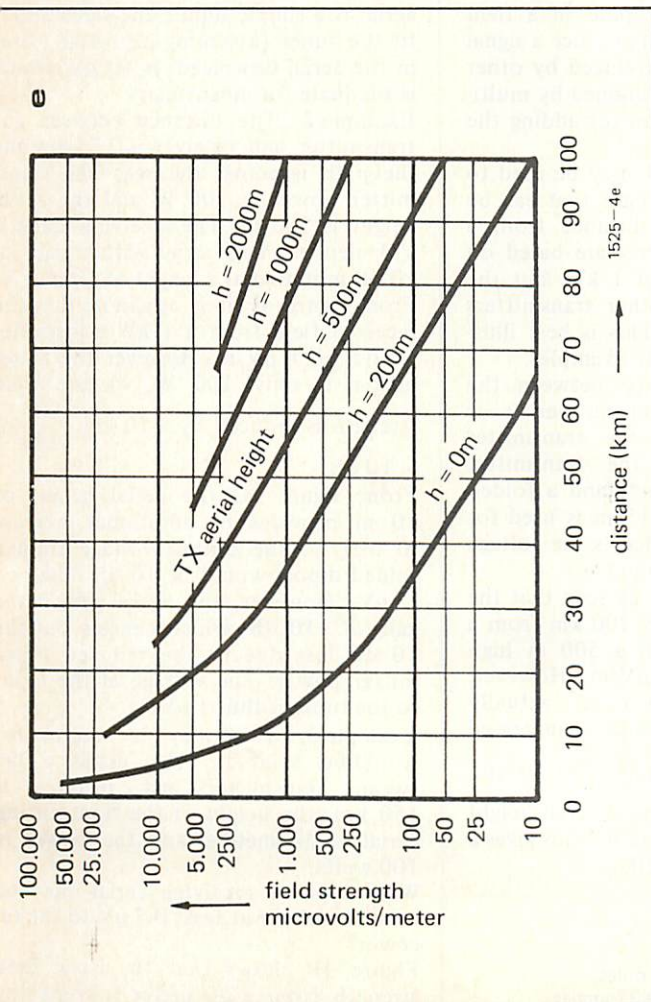
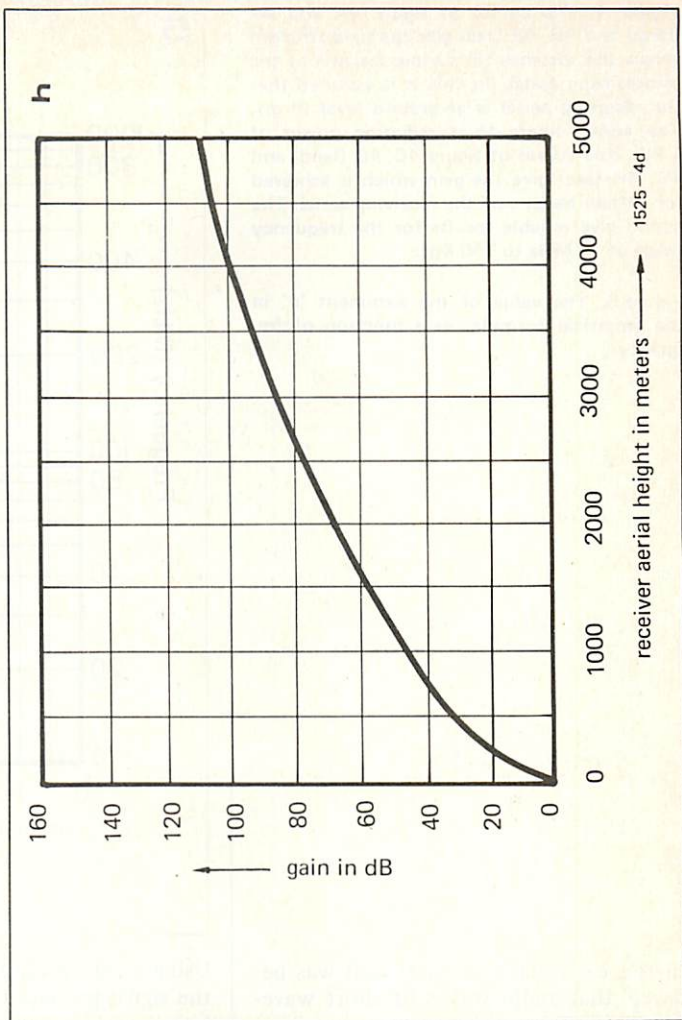
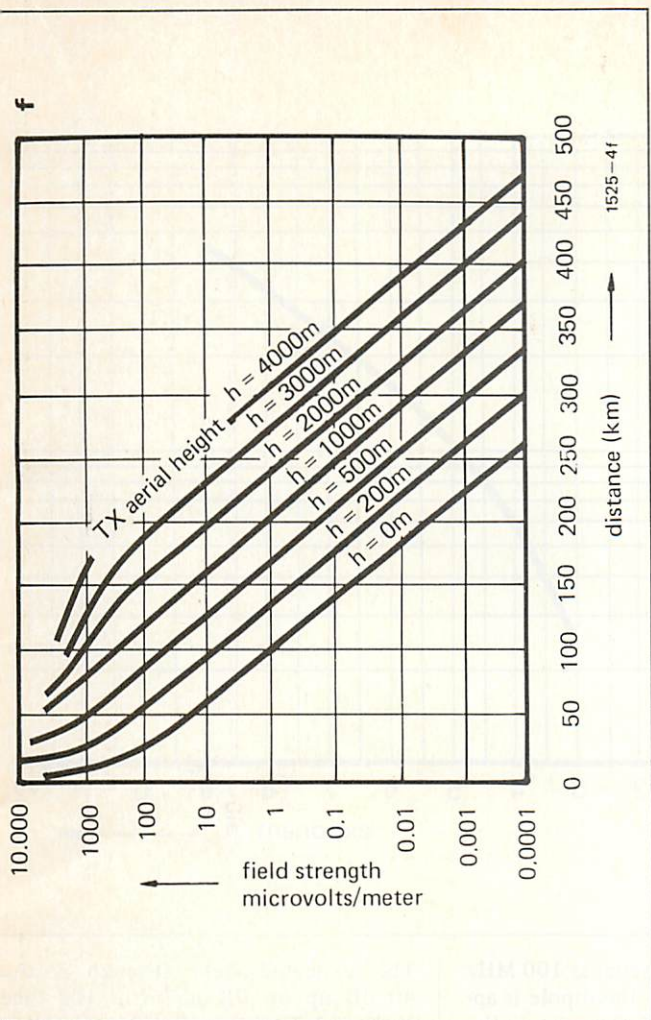
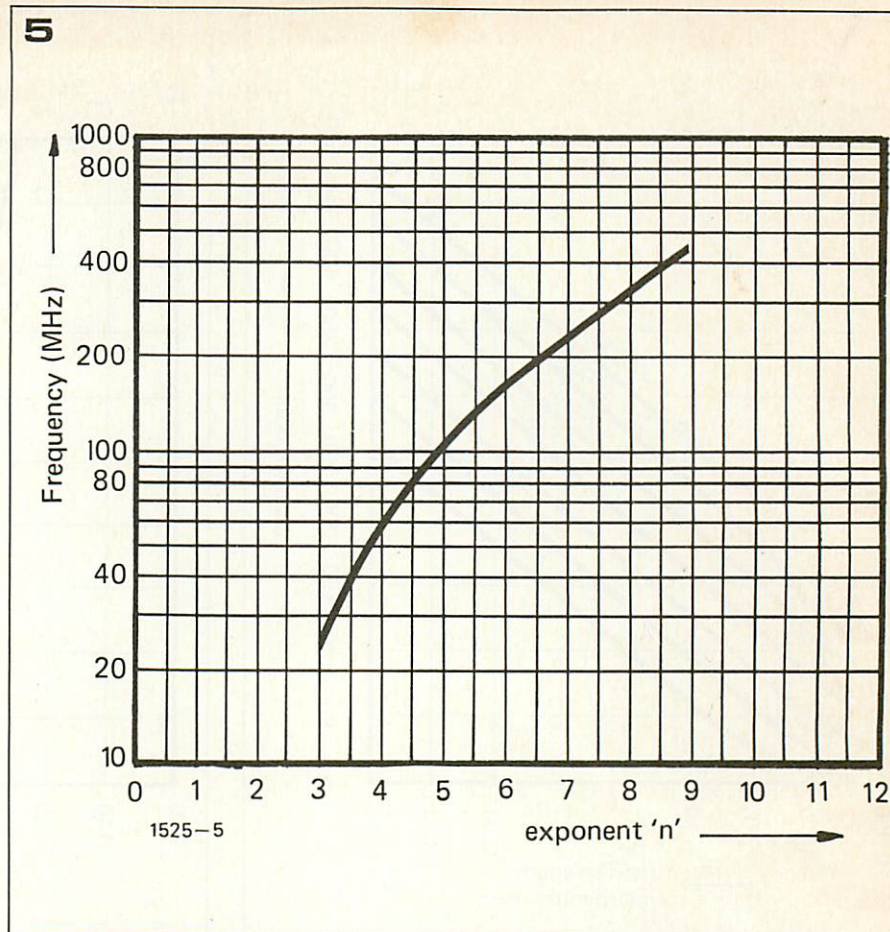

Figure 4. The curves of figure 4A and 4B (land) and 4E, 4F (sea) give the field strength versus the distance for various heights of the transmitting aerial. In this it is assumed that the receiving aerial is at ground level (0 m). The curves relate to a radiation power of 1 kW. The curves of figure 4C, 4D (land) and 4G, 4H (sea) give the gain which is achieved for certain heights of the receiving aerial. The curves give reliable results for the frequency range of 70 MHz to 150 MHz.

Figure 5. The value of the exponent 'n' in the empirical formula, as a function of frequency.



In the early days of wireless it was believed that radio waves of short wavelength (VHF) could only be transmitted over line of sight distances. It was thought that radio waves were rapidly attenuated once the receiver was below the optical horizon of the transmitter (figure 1). This is now known not to be the case. Due to differing electrical properties of the layers of the atmosphere reflections and refractions of the radio waves occur, so that the waves follow a curved path.

Radio waves can thus be received at reasonable signal strength even when the receiving aerial is below the optical horizon (figure 2). Figure 3 shows how the field strength of radio waves received by tropospheric reflection (shown dotted) are considerably greater than the field strengths of the ground waves at the same distance from the transmitter.

The factors that determine if a usable signal can be received from a particular transmitter may be tabulated as follows:

1. transmitter output power (it is assumed that transmitters radiate omnidirectionally);
2. the distance between the transmitter and the receiver aerials;
3. the height of the transmitting and receiving aerials (obviously if the aerials are higher the transmitter and receiver can be further apart before the receiver falls below the 'radio horizon');
4. the gain of the receiving aerial (relative to a simple dipole);
5. the minimum signal strength required by the receiver to produce a reasonably noise-free signal.

Using a folded dipole aerial at 100 MHz the signal produced by the dipole is approximately numerically the same as the field strength i.e. a dipole in a field strength of $1 \mu\text{V}/\text{m}$ will produce a signal of $1 \mu\text{V}$. The signal produced by other types of aerial can be obtained by multiplying by the aerial gain (or adding the gain in dB).

The curves of figure 4 may be used to establish the field strength that can be expected at a given distance from a transmitter. These curves are based on a transmitter power of 1 kW, but the field strengths with other transmitters can easily be found. This is best illustrated by means of some examples.

Example 1. The distance between the transmitting and receiving aerials is 200 km^* on land, the transmitter power is 100 kW, the transmitter aerial height is 500 m*, and a folded dipole at a height of 15 m is used for the receiving aerial. What is the voltage expected at the tuner input?

From figure 4B it can be seen that the expected field strength 200 km from a 1 kW transmitter with a 500 m high aerial is around $0.1 \mu\text{V}/\text{m}$. However, the transmitter power is actually 100 kW so the field strength is increased by $10 \log \frac{100}{1}$ (power ratio!) or 20 dB.

Furthermore, the receiving aerial height is 15 m, and from figure 4C this gives a further increase of 20 dB.

* 1 kilometer (km) = 0.62 miles;
1 meter (metre, m) = 39.37 inches.

The expected field strength is thus 40 dB up on $0.1 \mu\text{V}/\text{m}$ or 100 times (voltage ratio!) i.e. $10 \mu\text{V}/\text{m}$. Since the aerial is a simple dipole the signal input to the tuner (assuming negligible losses in the aerial download) is $10 \mu\text{V}$, which is adequate for most tuners.

Example 2. The distance between the transmitter and receiver is 175 km and the path is across the sea. The transmitter power is 100 W and the aerial height is 500 m. The receiving aerial is a 4 element Yagi array with a gain of 10 dB mounted at a height of 10 m.

From figure 4F it is apparent that the received field from a 1 kW transmitter would be $1 \mu\text{V}/\text{m}$. However the transmitter is only 100 W, so the field strength is reduced by $-10 \log \frac{1000}{100}$ or

- 10 dB.

From figure 4G the aerial height of 10 m provides no additional increase (0 dB), so the output voltage from the folded dipole would be 10 dB down on $1 \mu\text{V}$. However, the aerial provides a gain of +10 dB, which cancels out the 10 dB loss due to the reduced transmitter power. The voltage at the input to the tuner is thus $1 \mu\text{V}$.

Example 3. This may be useful for would-be spies... The distance between transmitter and receiver is 150 km, the height of the transmitting aerial is 50 meters, and the power is 100 watts.

What type of receiving aerial must be used to deliver at least $0.5 \mu\text{V}$ to the receiver?

Figure 4B shows that the basic field strength from a 50 meter transmitting

aerial at 150 km is $0.01 \mu\text{V}/\text{meter}$. Since a voltage of at least $0.5 \mu\text{V}$ is required at the receiver input, the basic gain requirement is equal to

$$20 \log \frac{0.05}{0.01} = 34 \text{ dB.}$$

However, that's for a 1 kW transmitter but the power in this case is only 100 W. Therefore the field strength is reduced by a further $10 \log \frac{100}{1000} = -10 \text{ dB}$.

Therefore, the receiving aerial will have to give a total gain of 44 dB (10 dB for the low transmitting power and 34 dB for distance). One possible way to achieve the 44 dB gain figure is to attach a folded dipole to a balloon floating at 250 meters. A more practical (?) solution is a 6-element yagi array with a gain of 14 dB mounted at 50 meters.

Example 4. This is of a more practical nature, and can be modified for individual circumstances. A 4-element aerial with a gain of 10 dB is mounted at a height of 20 meters, what receiving range can be expected for reasonably noise free FM stereo broadcasts?

First, some assumptions must be made: most FM transmitters have power outputs of 100 kW or more with aerial heights of over 200 meters; most receivers need approximately $100 \mu\text{V}$ for noise-free stereo reception.

Adding the basic receiving aerial gain (10 dB) to the gain due to receiving aerial height as derived from figure 4C (22 dB), a total aerial gain of 32 dB is found. Since the receiver requires $100 \mu\text{V}$, the 32 dB aerial gain means that a field strength of $2.5 \mu\text{V}/\text{m}$ is required at the aerial. If the transmitter power was 1 kW a look at figure 4B would show the distance.

However, the transmitter power is 100 kW. This means that the field strength at the receiving aerial is increased by $10 \log \frac{100}{1} = 20 \text{ dB}$ for

any given distance. 20 dB in field strength is a factor 10, so if a 100 kW transmitter gives the required $2.5 \mu\text{V}/\text{m}$ at a certain distance, a 1 kW transmitter would give a field strength of

$$\frac{2.5}{10} = 0.25 \mu\text{V}/\text{m} \text{ at the same distance.}$$

According to figure 4B, if the transmitting aerial height is 200 meters a 1 kW transmitter will give a field strength of $0.25 \mu\text{V}/\text{m}$ (so the 100 kW transmitter will give $2.5 \mu\text{V}/\text{m}$) at a distance of 150 km.

Or, looking at it the other way round, using the 4-element aerial at 20 meters height with an ordinary receiver it should be possible to get good (stereo) reception from any transmitter within a range of 150 km over land.

Of course, the results obtained from the graphs of figure 4 are true only where the transmission path is over the sea or over relatively flat terrain. If the receiving aerial is on top of a hill then the received field strength will be greater since the effective height of the aerial is greater. Conversely, if the receiving

aerial is in a valley the field strength will be less since the effective height of the aerial is smaller and the aerial will be screened by the walls of the valley.

Instead of using graphs, the received field strength may be calculated empirically from the equation given below, which takes account of the terrain by including a term for the distance to the optical horizon (obviously the distance to the optical horizon is greater for an aerial on flat terrain than for one mounted at the bottom of a valley).

The equation is as follows:

$$E = \frac{88 \cdot \sqrt{P} \cdot h_1 \cdot h_2 \cdot D_h^{n-2}}{\lambda D^n}$$

Where E is the r.m.s. value of the field strength in volts per metre;

P is the effective radiated power in watts;

h_1 is the height of the receiving aerial in metres;

h_2 is the height of the transmitting aerial in metres;

D_h is the distance of the optical horizon in metres (figure 1);

λ is the wavelength in metres;

D is the distance between transmitter and receiver in metres;

n is a frequency dependent exponent (see figure 5).

Both the curves of figure 4 and the empirical equation apply only for normal atmospheric conditions. During unusual weather conditions (such as inversion layers) VHF reception at distances of several thousand kilometres have been observed. This, of course, is not the norm, and is really of interest only to those interested in DX activities.

triac control

In simple triac phase angle control the trigger circuit contains only R4, P1, C1 and the diac. C1 cannot fully discharge in that circuit, so on later half-waves the triac fires sooner. This gives a 'snap-on' effect called hysteresis.

Adding resistor R2 and R3 and diodes D1...D4 leads to equal starting con-

ditions for every trigger-cycle. In this way, hysteresis effects are avoided.

Triac control units are notorious for causing interference on radio and TV. The easiest way to eliminate this is to add the LC low-pass filter consisting of L1, C2, C3 and R1. Coil L1 should be placed in the neutral line.

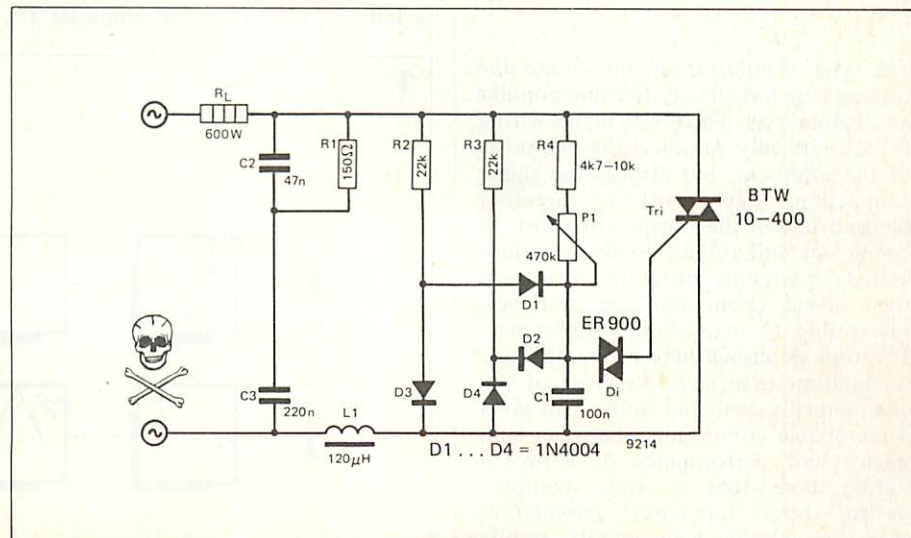

2

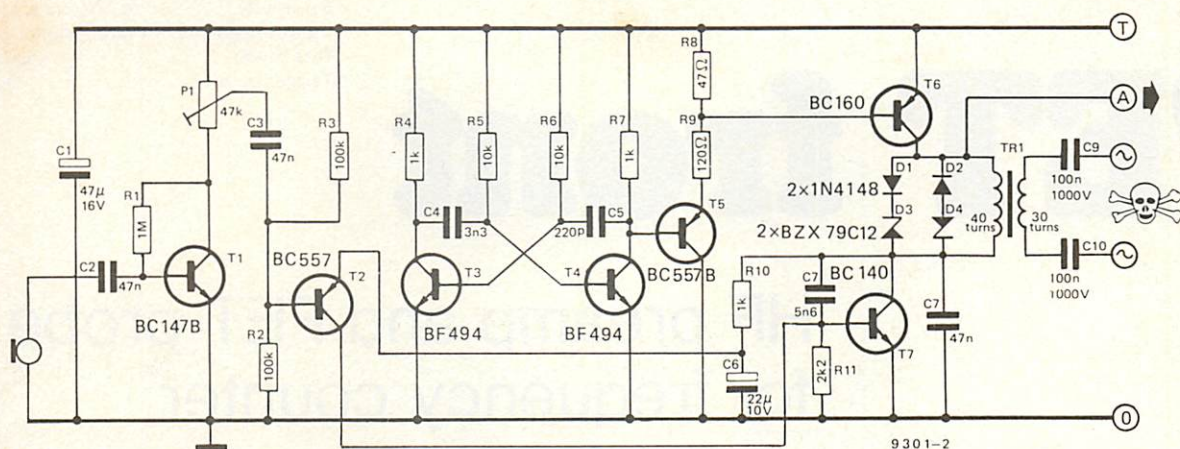

3

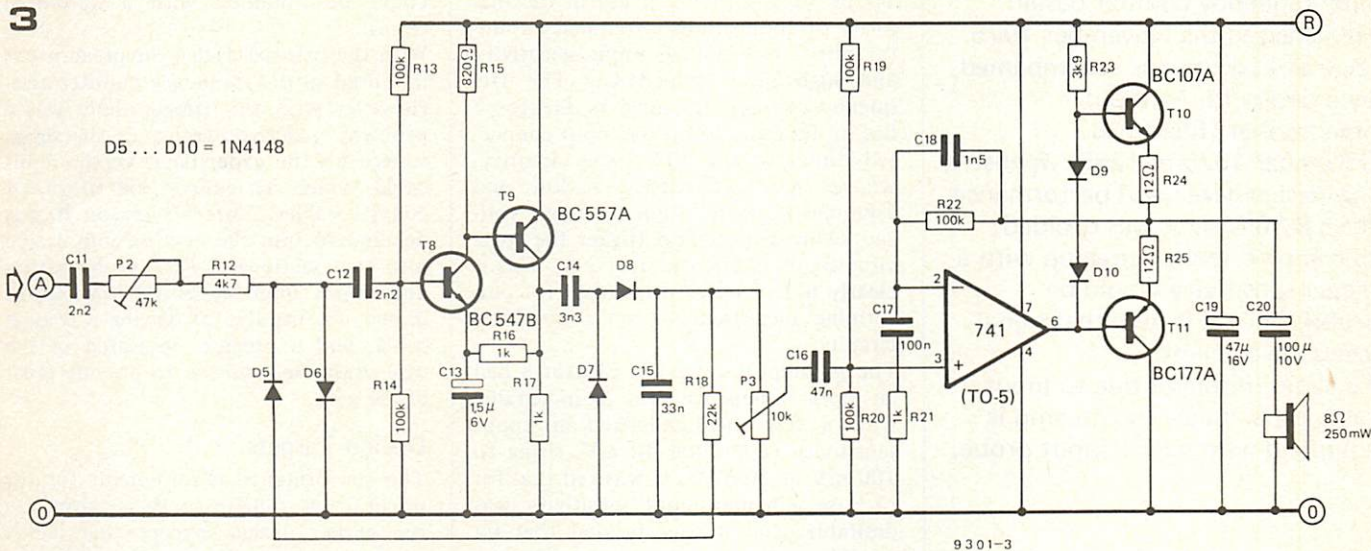

4

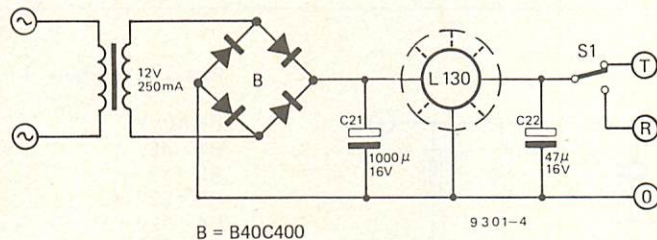

Figure 1. Block diagram of one post of the mains intercom. Each post is a combination of an a.m. transmitter and a conventional 'direct' receiver.

Figure 2. Circuit diagram of the a.m. transmitter. Either high or low impedance microphones may be used.

Figure 3. Circuit diagram of the receiver and the i.f. amplifier.

Figure 4. A suitable power supply for the intercom. S1 switches between transmitter and receiver.

controlled by P3.

It is advisable to set P2 as low as practicable (i.e. so that the modulation is at the audible threshold) as a considerable number of components will then remain below the detection level hence limiting the interference on reception as much as possible.

Conclusion

The simplicity of this design gives more than a hint of the quality of its performance. Since the transmitting power is fairly low (about 1 W) and interference suppression cannot reasonably be compared with that obtained with a narrow-band f.m. system, good performance can only be expected in a conventional one-family house. For a number of

applications, this will be sufficient.

Thanks to the low transmitting power though, the current consumption is very low, and a simple supply will do, and a simple supply diagram of a suitable supply using an IC L130. The switch S1 changes the supply between transmitting and receiving circuits.

The circuit is not very critical and can therefore be built without too much difficulty. The only obstacle may be the transformer which must be wound. For the prototype, a potcore AL250 with a diameter of 18 mm was used. Various manufacturers (e.g. Siemens, ITT and Philips) supply these potcores in a range of versions and sizes.

FET front

HF preamp and FET probe for frequency counter

Specification

Usable Frequency Range:	20 kHz-45 MHz
Sensitivity:	4 mV r.m.s. at 20 MHz
Input Impedance:	1 M in parallel with 5 pF
Rise Time:	approx. 5 ns
Trigger Level:	adjustable

The frequency counter design published in the November 1975 issue of Elektor was accompanied by a design for an input preamplifier (Elektor 8, December 1975 p. 1235). Whilst this design gave good performance from 0-20 MHz it was decided that for r.f. work a preamp with a higher sensitivity would be useful, since it is here that signal levels are smallest.

To avoid problems due to input cable capacitance the preamp is equipped with a FET input probe.

To be of any practical use in the majority of applications a frequency counter must have a high input sensitivity and high input impedance. The frequency counter described in Elektor 7 has, in its basic form, the input connected direct to the TTL logic circuitry, whose input impedance is low and asymmetric. In addition the input voltage swing required to trigger the logic circuitry is of the order of 2 V. This is clearly not of much use except for performing measurements on other logic circuits.

The preamp described in Elektor 8 had an input impedance of 1 M in parallel with a few picofarads and an input sensitivity of around 40 mV, rising to 100 mV at 20 MHz. It was felt that for r.f. use a higher input sensitivity was desirable, and it was decided that by sacrificing the low-frequency response (for reasons explained later) a high gain

could be obtained with a simplified circuit.

With the original design the preamp was mounted in the frequency counter case. However with this design there was a problem: reactive loading of the signal source by the capacitance of the input cable, which can be over 100 pF/m for coaxial cables. For this reason it was decided to split the new preamp design into two sections, a FET probe with a high input impedance and low output impedance capable of driving a coaxial cable, and a preamp, mounted in the case with the counter, to provide most of the gain.

Design Targets

The performance requirements for the preamp are similar to those given for the earlier design, except that higher input sensitivity is aimed at, while the low-frequency response is unimportant,

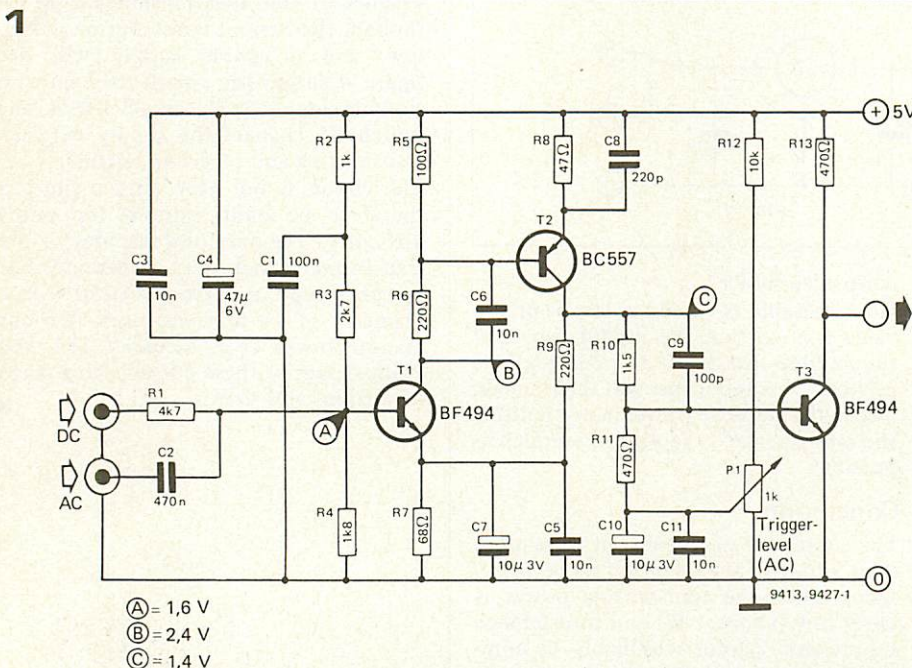

Parts List to Figure 1

Resistors

R1	= 4k7
R2	= 1 k
R3	= 2k7
R4	= 1k8
R5	= 100 Ω
R6, R9	= 220 Ω
R7	= 68 Ω
R8	= 47 Ω
R10	= 1k5
R11, R13	= 470 Ω
R12	= 10 k
P1	= 1 k

Capacitors

C1	= 100 n
C2	= 470 n
C3, C5, C6, C11	= 10 n
C4	= 47 μ/6 V
C7, C10	= 15 μ/3 V
C8	= 220 p
C9	= 100 p

Semiconductors

T1, T3	= BF494, BF194, BF195
T2	= BC557, BC157

since the circuit is specifically intended for r.f. work. The requirements are tabulated below.

1. Bandwidth. It was decided that the usable frequency range of the preamp should extend from the top end of the audio band to above the upper frequency limit of the counter (18 MHz).

2. Input sensitivity. It was decided that 10 mV was a useful value and could be obtained without resorting to complex circuitry.

3. Input impedance. This should be as high as possible i.e. input resistance should be high and input capacitance low.

These design requirements are met, and in some cases exceeded, by the new design. The usable frequency range of the preamp + probe extends from below 20 kHz* to above 45 MHz. At 20 MHz the input sensitivity is around 4 mV, whilst at 45 MHz it is still only 17 mV, which is better than the l.f. sensitivity of the original design. These figures refer to the r.m.s. input voltage necessary to cause an output voltage swing that will reliably trigger the TTL Schmitt input of the frequency counter. The impedance of the probe input is 1 M in parallel with 5 pF.

Preamp Circuit

The preamp circuit is shown in figure 1 and consists of a simple, three-stage, direct coupled amplifier. To minimise the effect of transistor capacitances and stray circuit capacitance the resistor values around the circuit are kept low. As a consequence of this the low-frequency response is sacrificed, since to extend the l.f. response down into the

* Frequencies below 20 kHz can be measured, provided the rise time is sufficiently short - less than 10 μ s.

3a

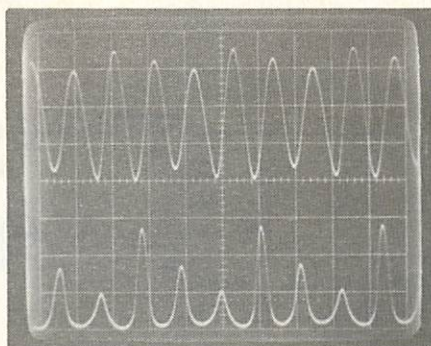

3b

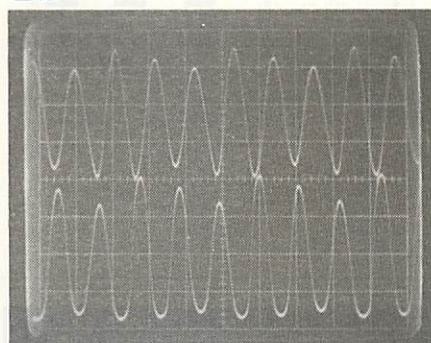

3c

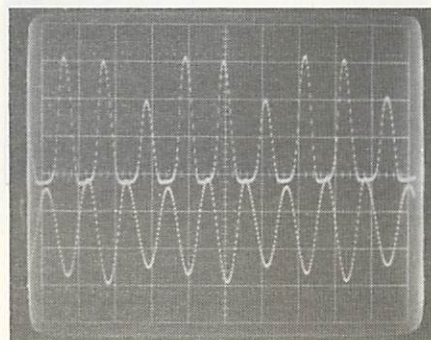

audio band excessively large value electrolytics would have been required for C2 and C7 (especially C7). Quite apart from the size consideration the parasitic inductances of such large electrolytic capacitors can cause undesirable resonances at higher frequencies.

The preamp is provided with two inputs, an a.c. input, which is normally fed from the probe output, and a d.c. input intended principally for low-frequency measurements on logic circuits. At low frequencies the d.c. input sensitivity is compatible with TTL logic levels. The a.c. trigger level control P1 sets the d.c. operating point of T3 and hence determines the input level at which it will turn on. With this control it is possible, when measuring complex waveforms, to trigger the frequency counter from either the fundamental or one of the harmonics as required.

Figure 3 shows the effect of varying the trigger level control. The upper trace of each oscillograph is an 18 MHz input signal with a high 3rd harmonic content. The lower trace in each case is the output of the preamp, with different settings of the trigger level control.

The graph of input sensitivity versus frequency for the preamp is given in figure 2. This shows the input voltage (r.m.s. mV) required for a 4 V peak-to-peak output swing. As can be seen from

Figure 1. Circuit diagram of the preamplifier. P1 adjusts the triggering level.

Figure 2. Graph showing the preamplifier sensitivity as a function of the input signal frequency.

Figures 3a, b, c. Oscilloscope shows the effect of trigger level adjustment by control P1 (see text).

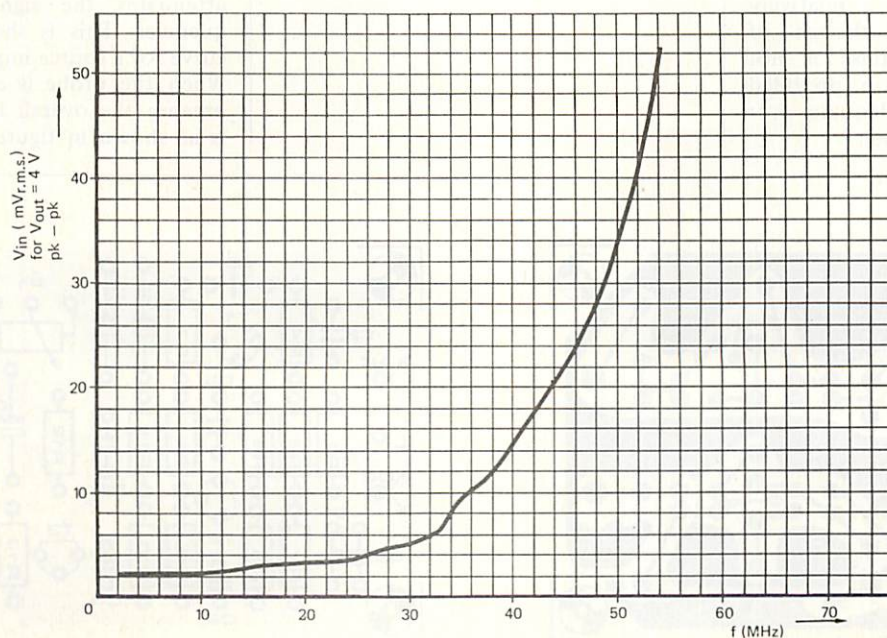

4

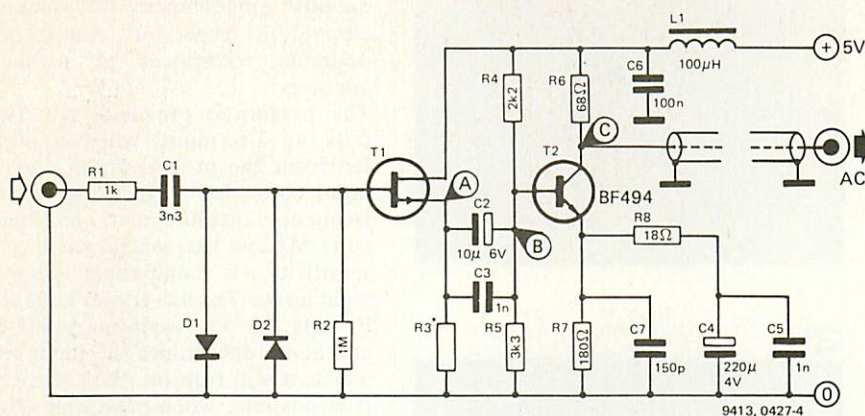

(A) = 1 V D1=D2=1N4148
 (B) = 3 V
 (C) = 4,2V

* see text

Parts List

Resistors

R1 = 1 k
 R2 = 1 M
 R3,R7 = 180 Ω
 R4 = 2k2
 R5 = 3k3
 R6 = 68 Ω
 R8 = 18 Ω

Capacitors

C1 = 3n3
 C2 = 10 μ/6 V
 C3,C5 = 1 n
 C4 = 220 μ/4 V
 C6 = 100 n
 C7 = 150 p

Semiconductors

D1,D2 = 1N4148
 T1 = E300,BF245C
 T2 = BF494,BF194,BF195

Inductors

L1 = choke 100 μH

the graph the required input voltage rises sharply above about 30 MHz, until at 45 MHz it is about 22 mV. Even so this is better than the original preamp design and is further improved by the addition of the probe, which also provides some gain.

Probe Circuit

To reduce the cost and simplify the circuit it was decided to use a single FET as the input stage instead of the dual FET used in the original circuit. T1 operates as a source follower to provide a high input impedance, with T2 providing a gain of about 2 and an output impedance of 68 Ω to drive the coaxial cable. Diodes D1 and D2 clamp the input voltage to ± 0.6 V maximum to protect the FET. The equalization network in the emitter of T2 helps to maintain a relatively flat frequency response, though of course a 'ruler-flat' response is not important in this application, provided the input sensitivity is adequate over the required frequency range.

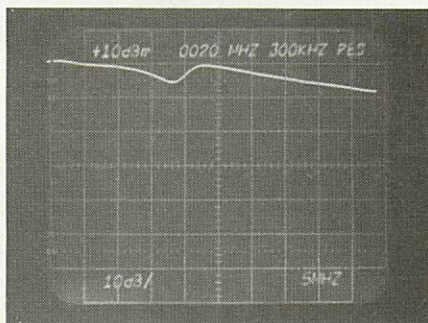

5

The FET used in this circuit is the tried and trusted Siliconix E300. Other FET's, such as the 2N5397, 2N5398, BF245C and BF256C may also be suitable. If an alternative FET is used it should be selected for a zero gate voltage drain current of at least 10 mA. R3 should then be selected to give a drain current of 3 to 5 mA with the device in the circuit.

Frequency Response

The gain of the probe circuit versus frequency is shown in figure 5 with the probe fed from a 50 Ω source. At the low frequency end the gain is about 2, and the response exhibits a slight rise up to about 60 MHz, after which it falls off. If the probe is fed from a high source impedance then the shunt capacitance of the probe impedance quickly attenuates the signal at higher frequencies. This is shown in the dashed curve for a source impedance of 10 k. When the probe is combined with the preamp the overall frequency response is as shown in figure 8. At 1 MHz the

6

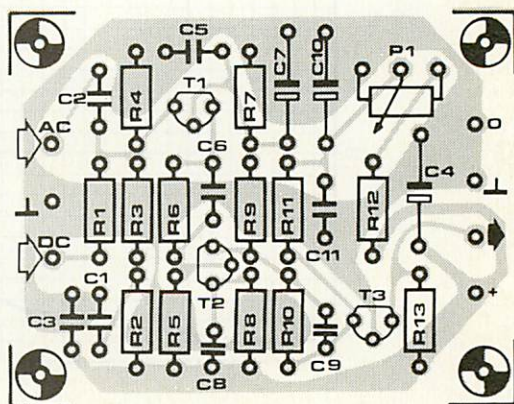
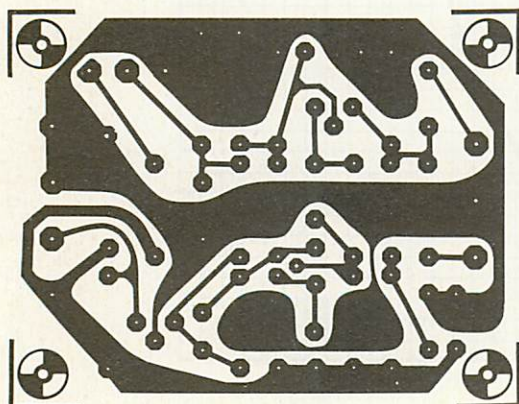

Figure 4. Circuit diagram of AC FET probe.

Figure 5. Fet probe gain as a function of frequency. The probe is terminated into 50 Ω. Spectrum analyzer display shows frequencies from 100 kHz to 50 MHz (left to right). The input signal to the probe was 0 dB. The gain of the probe by itself isn't of much importance, because its main job is as an impedance match.

Figure 6. Preamp p.c. board and component layout (EPS 9413).

Figure 7. FET probe p.c. board and component layout (EPS 9427).

Figure 8. Probe-plus-preamp sensitivity as a function of the input signal frequency.

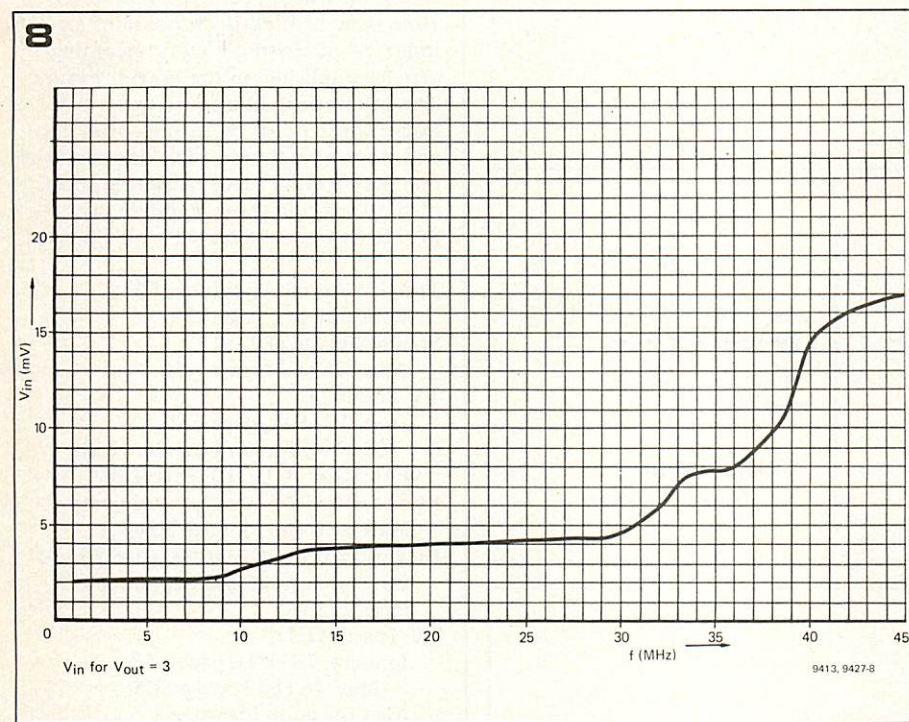
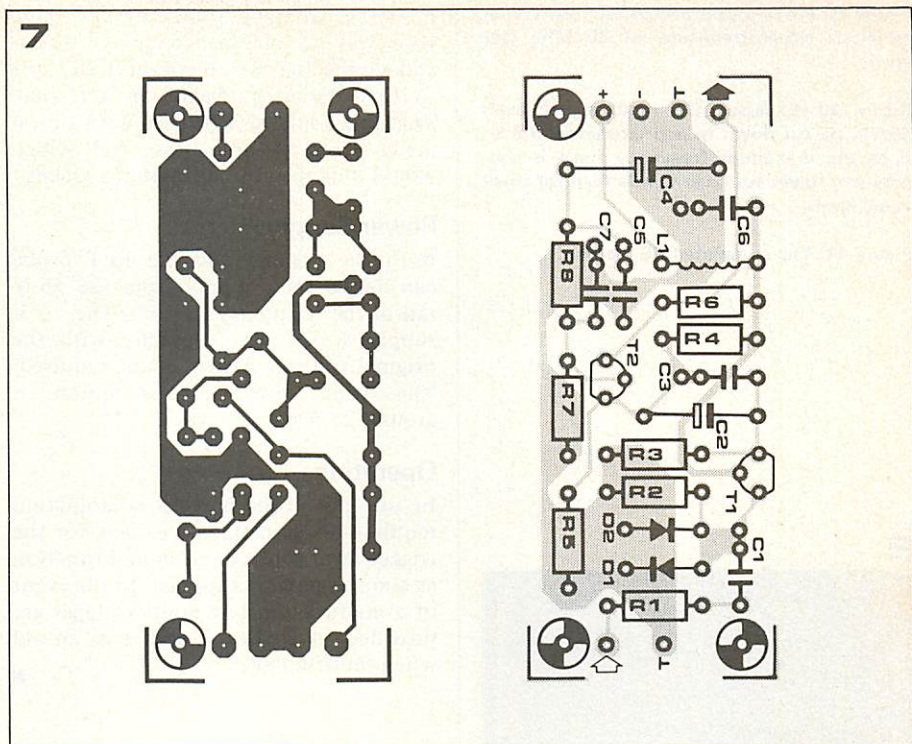

input sensitivity is around 2 mV, while at 45 MHz it is still only 17 mV, which is sufficient for many applications. Figure 9 shows an oscillograph of the preamp output to the probe at 40 MHz. The upper trace is the 40 MHz input signal (scale 20 mV/cm) whilst the lower trace is the preamp output (scale 1 V/cm). The timebase speed is 20 ns/cm.

Construction

A p.c. board and component layout for the preamp is given in figure 6, and for the probe in figure 7. Normal r.f. practice should be followed when mounting the components on the boards i.e. the component leads should be kept as short as possible, especially the transistor leads.

The preamp may be mounted in the frequency counter case, and is connected to the FET probe by a length of 50-75 Ω coaxial cable. The supply lead to the probe can be run alongside the cable. The housing for the probe is a matter of individual taste. The board is sufficiently small to fit in a small box folded from sheet aluminium. A test prod made from brass rod may be connected to the probe input through an insulating bush in the end of the box so that the probe may be used as a hand-held unit.

The ground connection to the probe input may be made with a crocodile clip on a flying lead. Alternatively the probe input connections may be made using 4 mm sockets, as shown in figure 11. Short flying leads ter-



Figure 9. Probe-plus-preamplifier response at an input signal frequency of 40 MHz (see text).

Figure 10. Excessive DC input signal levels should be cut down to approximately 0.5 V, since the maximum frequency limit is considerably lower for large signals than for small signal levels.

Figure 11. The completed FET probe.

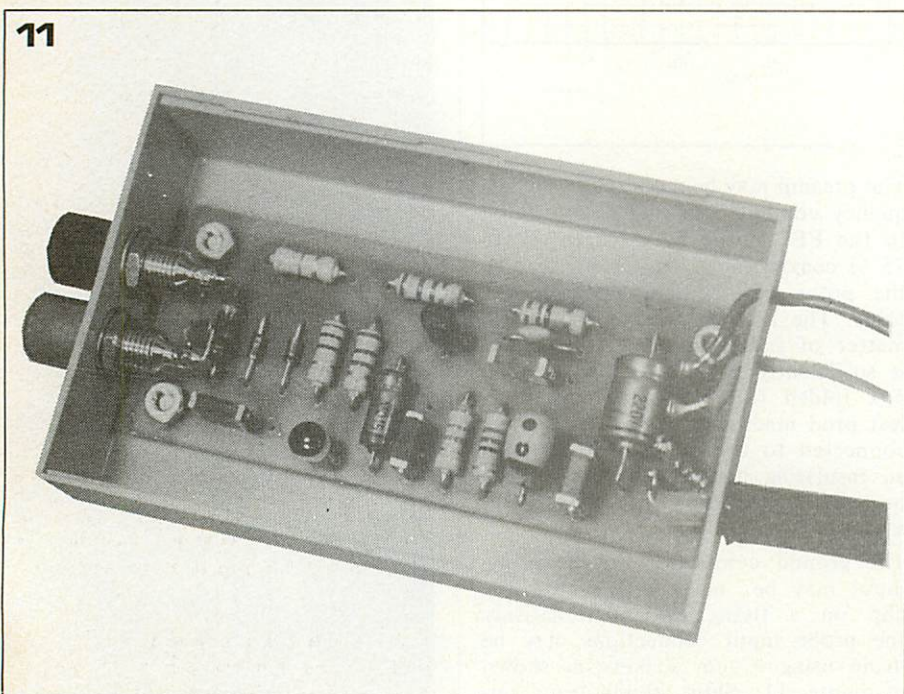
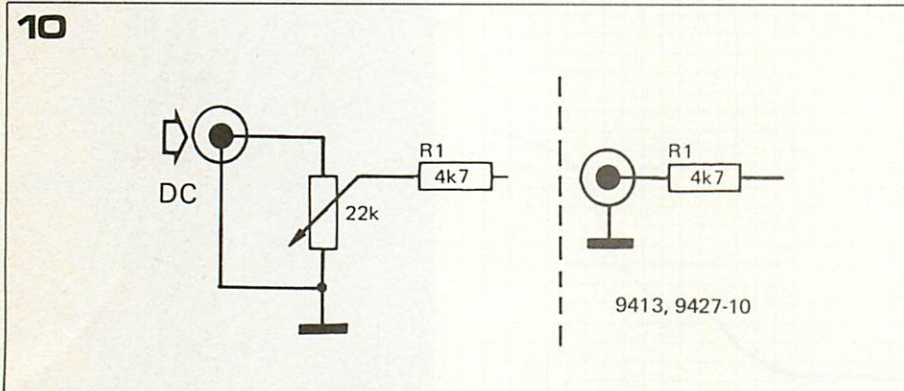
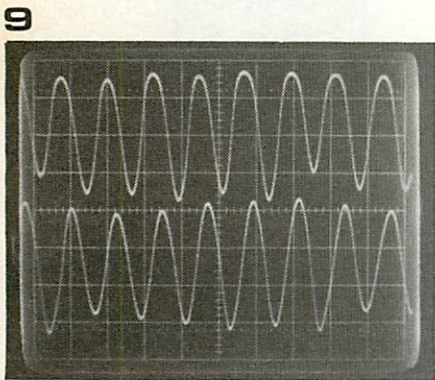

minating in test prods or crocodile clips may be then be plugged into these and connected to the circuit under test so that the user's hands are left free. The unit could also be used with a prod made from 4 mm brass rod which would plug into the signal input socket.

Power Supply

Both the preamp and the FET probe can derive their supply from the +5 V rail in the frequency counter. The -5 V supply which was necessary with the original preamp design is not required. The total current consumption is around 25 mA.

Operation

In use the probe/preamp combination requires no adjustments except for the trigger level control and should function as soon as power is applied. In the event of a malfunction test point voltages are provided in figures 1 and 4 as an aid when faultfinding.

THE MISSING
THE
MIS
SING
LINK
THE
MISSING
LINK
THE
MISSING
LINK

LINK 75

Cumulative index of 'Missing Links'.

The Link will appear each year in the June issue of Elektor. It contains an index to all Missing Links concerning articles published in the previous year. The intent of the link is to assist the home constructor by listing corrections and improvements to Elektor circuits in one easy to find place. A simple check of the Link will show whether any problems were associated with a project.

Tunable Aerial Amplifier (E1);

February 75, page 229.

Steam Whistle (E1);

April 75 (E3), page 458.

TV Sound (E2);

June 75 (E4), page 660.

CA 3090 AQ Stereo Decoder (E5);

February 76 (E10), page 230.

BC516/BC517 Transistor problems;

March 76 (E11), page 354.

Diagram for the CA 3080, page 755 of

E5, is incorrect; see September 75, page 952.

TV Tennis (E7);

January 76 (E9), page 148;

May 76 (E13), page 508.

Also for good ideas see

March 76 (E11), page 318.

Lie Detector (E7);

April 76 (E12), page 454.

TCA 730/740 (E8);

January 76 (E9), page 148.

Pre-amp for counter (E8);

April 76 (E12), page 454.

Missing Links concerning articles in volume 2:

Feedback PLL for FM (E9);

February 76 (E10), page 230.

Capacity Relay (E9);

February 76 (E10), page 230.

Digital Master Oscillator (E10);

April 76 (E12), page 454.

Morse Typewriter (E10);

May 76 (E13), page 508.

EJEKTOR EJEKTOREJ

conductance) of the two amplifiers used in the gyrator, so for each amplifier:

$$i_{out} = \pm g \cdot v_{in}$$

(the + sign for the non-inverting amplifier, the - sign for the inverting amplifier).

Compare this with the basic OTA formula:

$$i_{out} = \pm g_m \cdot v_{in}$$

The similarity is obvious!

A bias current sets the value of g_m . For a CA 3080, say, the transconductance equals:

$$g_m = 19.2 \times I_{ABC}$$

This means that if OTAs are used in a gyrator circuit, the gyration constant is a linear function of the bias current (I_{ABC}).

From this it follows that the resonance frequency must also be a linear function of the bias current. The quality factor will also be proportional to the bias current, provided the input impedance of the OTAs is large compared to R . If, however, the OTA input impedance determines the value of R , the quality factor will be almost constant over the whole band.

This means that a simple DC adjustment will suffice to sweep such a filter over a 1000:1 frequency range ($0.1 \mu A \leq I_{ABC} \leq 100 \mu A$), while maintaining either constant bandwidth or constant Q !

A possible circuit is shown in figure 2. The only thing wrong with it is that it doesn't work properly... Provided the input signal level was kept very low, the filter worked as expected. At slightly higher signal levels, however, a sort of 'lock-on' effect occurred: the output level suddenly jumped to a much higher value, and maintained this higher value over quite a broad frequency range. Outside that range it would suddenly drop back again to the original low level.

Literature: 'How to gyrate — and why': Elektor 2, p. 255; 'OTA': Elektor 6, p. 927.

one octave lower

Musicians nowadays tend to use more and more bass guitars, bass clarinets, and the like — as far as possible, that is. For this reason, they are faced with the problem of having to buy and carry around more and more (expensive) instruments.

Electronic circuits that would transpose the sound of particular instruments down over one or two octaves would be a welcome relief.

1

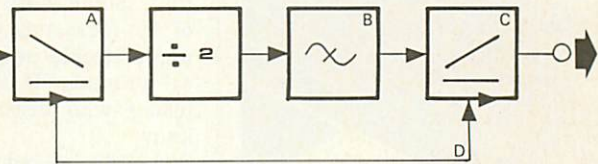

A = Compressor

B = filter

C = expander

D = control voltage

2

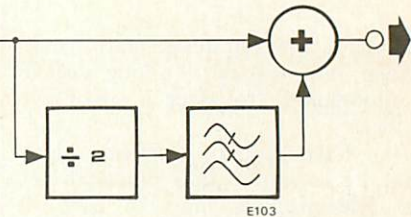

Several factors determine the 'sound' of a particular instrument: wave shape, attack, decay, non-harmonic sounds (e.g. wind noises), changes of harmonic content as a function of amplitude, etc. For this reason it is not normally possible to retain the same 'sound' when the original signal is passed through a simple divide-by-two stage to transpose it over one octave.

There are, however, several possible approaches to the problem; the best approach for one instrument may be of no use for any other instrument. A few ideas will be given here — further development is left to electronic musicians or musical electronics engineers....

Guitar. It has been found that a simple divide-by-two circuit followed by suitable filters can give quite reasonable results for a guitar. However, during the decay time the system tends to 'stutter' as the input signal drops below the trigger level of the divider, so this basic system is musically useless. It will therefore be necessary to add a compressor stage in front of the divider to keep the input to this at a relatively constant level; an expander before or after the filters can restore the original amplitude relationships.

A block diagram of this arrangement is shown in figure 1.

Trombone. Several brass instruments (and several string instruments as well!) have a spectrum consisting of both even and uneven harmonics with a gradually decreasing relative amplitude. To transpose an instrument of this type over one

octave, it should be sufficient to add one 'sub-harmonic' to the original signal. This must be done in such a way that the original fundamental becomes the second harmonic of the new, added, fundamental — with the correct amplitude relationship.

An advantage of this system (sketched in figure 2) is that the original 'sound' is retained to a very large extent.

Clarinet. Several woodwinds, including the clarinet, have a spectrum consisting mainly of uneven harmonics with gradually decreasing relative amplitude. The even harmonics are at a much lower, and fairly constant, level of approximately -20 dB.

To transpose the sound of this type of instrument it should be possible to use the same basic system as that described for the trombone. The difference is that in this case the new 'sub-harmonic' fundamental must be one-third of the frequency of the original fundamental. This means that a divide-by-three stage will have to be used, and that the instrument will be transposed over one octave plus one quint... this could be a nuisance!

EJEKTOR EJEKTOREJI

1

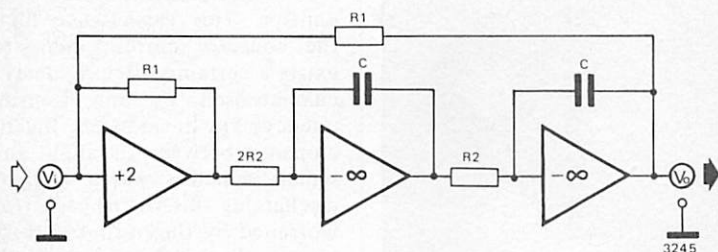

filter without phase-shift

A problem that occurs regularly in control systems using negative feedback is instability at high frequencies. If the system contains a non-minimum phase element, say, the total phase shift at high frequencies can become 360° while the total gain around the loop is still more than unity.

If a low-pass filter is added inside the loop to reduce the gain to a safe level at high frequencies, the law of

conservation of misery dictates that the point where the phase shift is 360° will also move down to a lower frequency - where the gain is still more than unity, in spite of the additional filter!

What is needed is obviously either a completely new design, or else a filter that does not introduce phase shift in the frequency band that matters.

The basic principle of a filter of this kind was published in an earlier issue of Elektor: the 'Frequency dependent resistor' (Elektor 5).

The circuit is repeated here (figure 1). It should be made clear that this is only a basic block diagram; it is also assumed for the present that the amplifiers have infinite gain and zero phase shift.

In this case the total transfer function is:

$$\frac{v_o}{v_i} = \left(\frac{1}{j\omega\tau}\right)^2$$

in which

$$\tau = R_2 \times C$$

The input current is therefore:

$$\begin{aligned} i_i &= \frac{v_i - v_o}{R_1} + \frac{v_i - 2v_i}{R_1} = \\ &= \frac{v_o}{R_1} = \frac{1}{R_1 \omega^2 \tau^2} \times v_i \end{aligned}$$

which means that the input impedance is:

$$z_i = \frac{v_i}{i_i} = R_1 \omega^2 \tau^2.$$

This is a real resistance - with current and voltage in phase - but increasing with the square of the frequency.

If the output is left open, this frequency dependent input resistance can be used to construct a filter without phase shift - the limitation being the frequency where the amplifiers start to introduce phase shift. It's a fundamental law that there must be phase shift somewhere!

To give an example, if a signal is fed in via a resistor and the output is taken from the input of the frequency dependent resistor, the result is a high-pass filter without phase shift at the roll-off point.

Literature: Elektor 5, p. 712.

COMING SOON

The next Elektor is the July/August 'Summer Circuits' issue. It contains over 100 projects and design ideas, from control units for solar heating panels to speech garblers.

Some circuits are basic design ideas, such as a monoflop using a single 7400. Others come with p.c. board layouts and are complete functional units, an example is a pulse generator with variable pulse width and repetition rate.

It should be made clear that this issue is not a review of circuits already published, nor is it a preview of designs that will be published in the coming year.

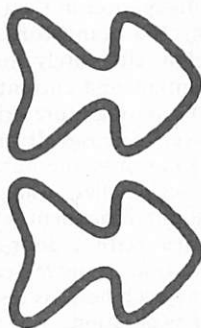

- dark room timer
- rain synthesiser
- car clock
- kettlestat
- current source
- battery indicator
- antenna amplifier
- logic tester
- wind machine
- min/max temperature indicator
- digital contrast
- power supply
- SSB adapter
- wideband frequency doubler
- headphone adapter
- pulse generator
- over 84 other circuits



There is always something new under the rising sun. The Japanese have now developed a semiconductor called 'vertical field effect transistor', intended for use in high power output stages. The V-FET performance and basic characteristics are vastly superior to the common bipolar transistors.

This article describes the V-FET's construction and operation, along with its application in commercial circuits.

Circuit Requirements

As unlikely as it may seem, a firm market seems to be developing for heavy, (i.e. 60-120 lbs) stereo output amplifiers capable of feeding some 150-350 watts to the $8\ \Omega$ load of each channel. Obviously, the quality of these 'audio power houses' is dependent on the characteristic properties of the active elements used in their output stages. Consider some of the difficulties which are associated with high output power. First, there is the problem of high heat dissipation in the final transistors. Then, the transistors themselves are subjected alternately to high collector potentials and currents, with the condition becoming more critical as the output power increases. It may even be necessary to arrange the output transistors in series-parallel, using the same principle as the coachman who replaces a single horse with a four-in-hand, so that the output is increased although the effort by each horse is less.

Further considerations for the output circuit designer are the switching properties of the transistors to be used. In the familiar class B final stage, the two halves alternate between a current-conducting and a current-blocking function which is, ideally, under the com-

plete control of the signal from the driving amplifier.

However, this is hardly ever the case in practice, since power transistors are not capable of following fast input signal variations, due to the non-linear diffusion capacitance between the base and emitter. This capacitance increases as the collector current increases. There exists a certain switching delay which is characterised by the transition frequency, f_T . In addition, the phase discrepancy between the input and output signals, which is caused by charging and discharging this virtual capacitor, can be worsened by the output transistors clipping (although this clipping should be prevented in the preceding stage by limiting the driving swing to an amplitude that will not drive the final output signal against the power supply voltage). These transition imperfections cause a reduction in efficiency, i.e. an increase in the heat dissipated, so much so that, in some cases, it may be necessary to install a cooling fan.

High f_T transistors capable of following fast input signal variations at large amplitudes are more vulnerable than low f_T types under overload conditions, due to their construction and manufacturing technology. In particular, it is the second breakdown phenomenon, occurring at high collector voltages during high heat dissipation, that can lead to their complete destruction. This danger can be avoided by respecting the I_C - V_{CE} diagram that shows the Safe Operating Area (SOAR), which indicates the safe combinations of collector voltage and current. It can be seen that for high f_T types this area is considerably smaller than that for the more robust 2N3055 family, and good protective circuitry is badly needed.

Transistors respond inversely with the emitter current, i.e. as the emitter current rises, the response falls off. A water tap provides a suitable metaphor: between the order to turn off the water and the completion of the action, the water continues to flow, with the volume of the wasted water being dependent on the number of turns that the tap was turned on. Unlike electronic valves and FETs, the base of a bipolar transistor always draws some current, which can be of considerable magnitude in the case of high power transistors. It follows from the above considerations that there is an urgent demand for an alternative high power active semiconductor with improved characteristics and higher safe ratings for heat dissipation, current and voltage. There are, admittedly, improved transistors such as the low emitter concentration (LEC) types, but at the moment they are only suitable for small signal applications. The demand for transistors for large signal applications still remains. However, it appears that it is in this region that the V-FET will be useful.

Horizontal FETs

Before discussing the new V-FET, it is worth mentioning some aspects of the

Figure 1. Conventional (horizontal) FET construction. The hatched area around the gate indicates the depletion zone caused by the non-conducting state of the pn junction. With a constant V_{GS} , an increase in the drain current causes the depletion zone to grow as indicated by the dotted line, until it impinges on the edge of the substrate. At this point further increases in the drain potential V_{DS} fail to cause an increase in the drain current which may be regarded as saturated.

Figure 2. Drain current I_D expressed as a function of V_{DS} with parameter V_{GS} for the FET of figure 1. The dotted line shows the knee potential as a function of V_{GS} .

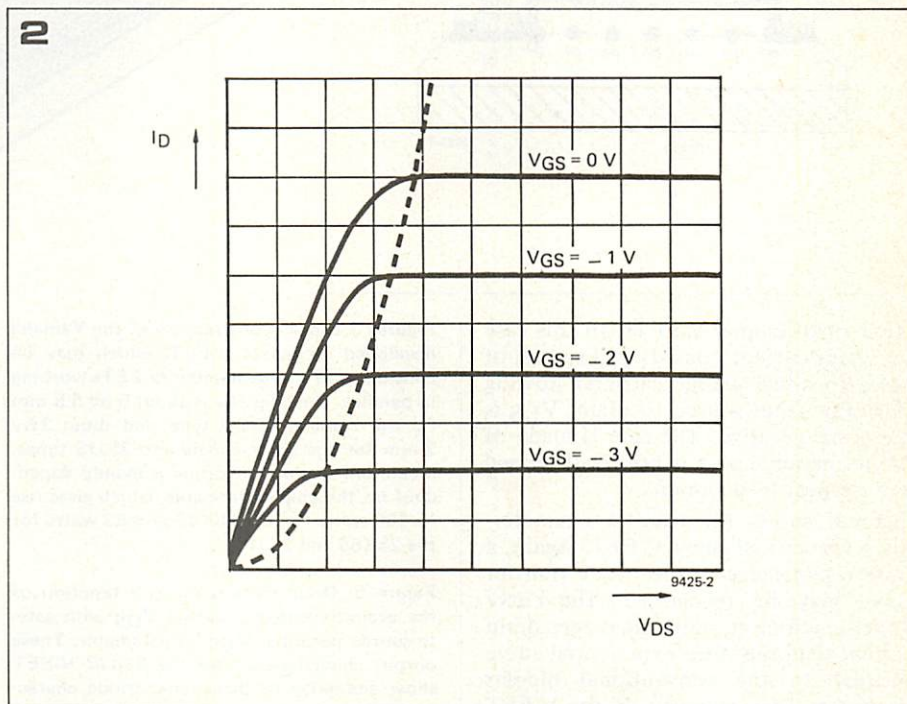
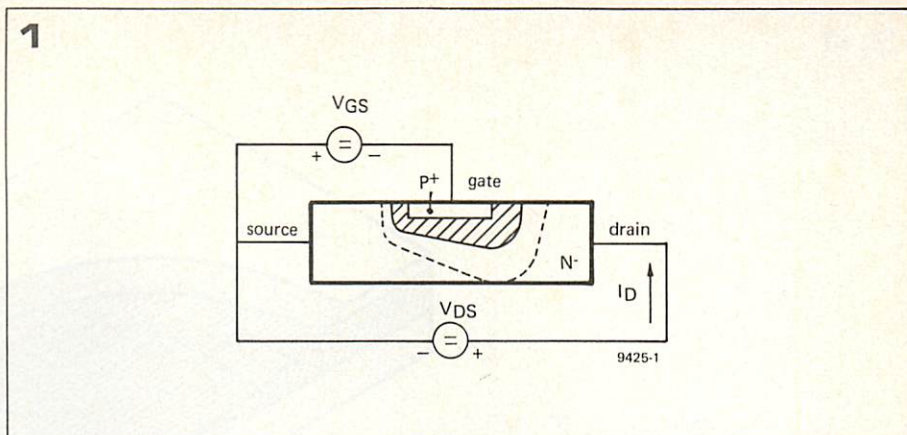

conventional (horizontal) FET, which is only suitable for low power applications such as circuits with high input impedance and low noise. Figure 1 shows the construction of an ordinary n-channel FET. A positive potential between drain and source causes electrons to flow from source to drain. The gate is made of p-type material, and when a negative potential with respect to the source is applied to it, the pn junction becomes non-conductive. Now the junction is surrounded by a depletion zone (hatched in the figure) which is completely empty of majority charge carriers. Figure 2 shows a family of output curves. For a given V_{GS} , the drain potential V_{DS} and the drain current I_D increase linearly at first. The current increase extends the depletion zone until the point at which the zone touches the opposite edge of the substrate (shown by the dotted line in figure 1). Any further increase in V_{DS} fails to increase I_D , so the FET virtually behaves as a constant current source for any higher values of V_{DS} . The output curves also show that more negative values of V_{GS} cause the 'knee' to occur at a lower V_{DS} so reducing the corresponding saturation current. The position of the knee for varying V_{GS} is shown by the dotted line.

Vertical FETs

Both Sony and Yamaha have now developed high power FETs whose properties are very promising. The construction and manufacturing technology of the Sony and Yamaha devices are similar in that both may be considered to be made of a large number of 'mini-FETs' working in parallel, but in other respects the two devices are quite different. Sony have developed both p-channel and n-channel V-FETs, whereas Yamaha have only developed an n-channel type. Consequently, the circuits utilising these new devices differ considerably in their design, as will be discussed later.

Figures 3 and 4 show the construction of the Yamaha n-channel device. Compared with the horizontal junction FET, the current flows vertically. The drain is located at the bottom of the crystal and its mechanical connection to the casing has a very low thermal resistance, which is vital since practically all the heat produced inside the device is developed in the drain and must be led away from there. The channel is made of N^- type material into which a grating of P^+ type material, the gate, has been embedded. In figure 4, each square represents a separate FET, at 5 to 10 micron spacings. The entire chip size is about

5 mm by 5.5 mm and it consists of tens of thousands of FETs, all working in parallel.

The output characteristics of these FETs are shown in figure 5, and a major difference from those in figure 2 is immediately obvious: there is no knee, or corresponding saturation voltage. Readers once familiar with the output curves of the old faithful triode will no doubt be struck by the resemblance, which has already been used in the publicity given to these new devices, as nostalgia is a great selling point. Those readers will remember the one-upmanship in the triode-fitted amplifiers against the pentode-equipped counterparts with their inherent current-saturation effects. However, the comparison is not really fair, as modern circuits with high negative feedback (made possible by the elimination of the output transformer) display hardly any distortion of this kind. On the other hand, it is much easier to trim an amplifier which is inherently devoid of clipping and other nasties, than one which is full of these distortions. V-FETs present other advantages than merely being free of these annoyances.

The family of output curves in figure 5 may also be used to describe the oper-

3, 4

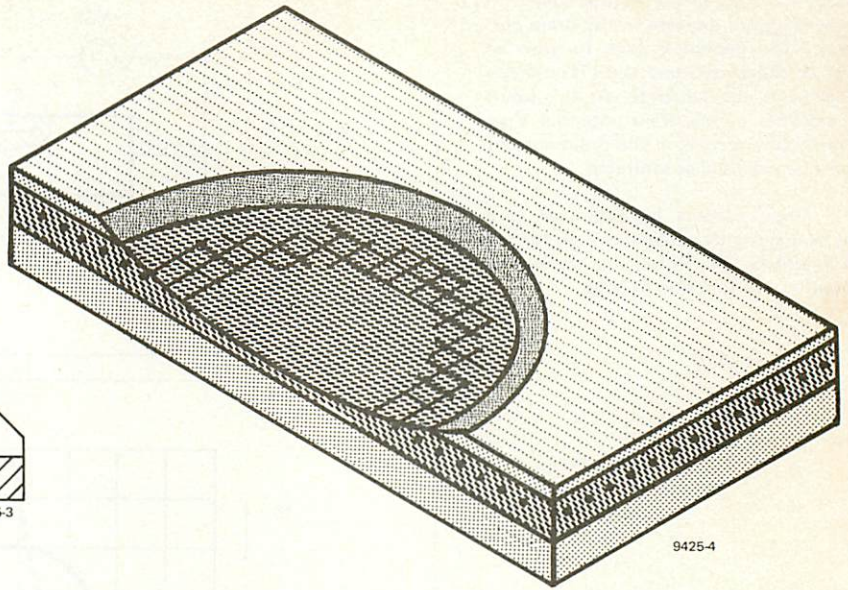
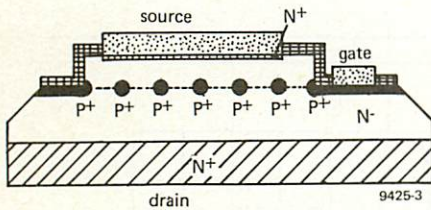

ation of p-channel V-FETs. In this case the drain current consists of a stream of holes (positive charge carriers) flowing vertically from source to drain. V_{DS} is therefore negative. The gate is made of n-type material and is positively biased with respect to the drain.

Figure 6 shows the transfer characteristics for an n-channel V-FET. Again, a close resemblance to the triode transfer curve may be recognised. The curve slopes much more gently near zero drain current than the steep exponential curve peculiar to the conventional bipolar transistor. This property of the V-FET is favourable for rounding the cross-over point in class B power stages. It must be admitted that the slope of the transfer characteristic can be adversely affected by fluctuations in the supply voltage or in the drain-source potential (such as would be caused by a drain load impedance). This is due to the negative feedback acting on the drain potential. The equivalent effect with thermionic triodes is the difference in transfer characteristics between the dynamic and the no-load output.

Performance Figures

The data sheet gives some interesting figures for different types of V-FETs. Particularly impressive are the maximum ratings for the Yamaha 2SK77 type, they are not likely to be equalled by any conventional power transistor. All types permit a very high maximum drain-to-gate potential, which is the highest potential found in a V-FET. All types are completely free from secondary breakdown effects, since the density of the drain current is the same throughout the channel. This is due to the absence of current crowding and also to the manufacturing technology which permits an extremely low level of contamination in the n- (or p-) channel. Although the V-FET is basically a

vertical-controlled device, the gate does, nevertheless, draw some current, as the input impedance is not quite so high as in the horizontal FET. This input current consists of an inherent leakage current through the barrier between gate and channel, and a capacitive current caused by the charge and discharge of the source-gate capacitance and the virtual capacitance due to the Miller effect on the gate. Consequently, the currents required to drive the 2SK77 are so high that a source-follower driving stage is needed (see figures 7 and 8), for which the type 2SK75 has been developed (see table). In spite of this, V-FETs offer some important advantages over conventional power transistors. For one thing, the input capacitance is smaller and almost independent of the drain current. For another, the transition speed of all these V-FETs is 5 to 10 times faster and the power switched at these frequencies is 2 or 3 times higher than for the fastest bipolar transistor. High frequency distortion at the cross-over point is practically non-existent, especially with optimum setting of the quiescent current in the output stage.

Figure 5. Drain current I_D as a function of the drain-to-source potential V_{DS} with gate-to-source potential V_{GS} as parameter. These output characteristics for the 2SK77 V-FET show similarity to thermionic triode characteristics.

Figure 6. Transfer characteristics for the 2SK77 V-FET: drain current I_D as a function of gate-to-source potential V_{GS} with drain-to-source potential V_{DS} as parameter. Any load in the drain circuit causes the slope of the dynamic transfer characteristic to drop, with the exception of the curved portion near the cut-off point. These characteristics show that the optimum quiescent current (i.e. a working point where the slope has half the gradient of the full swing slope for a class B stage) should be about 400 mA.

Figures 7 and 8. Stripped version (figure 7) and complete circuit diagram for one stereo channel of the Yamaha B-I output amplifier. This circuit clearly resembles the direct-coupled output circuit for thermionic valves and 800 Ω loudspeakers.

An exclusive and very recommendable V-FET property is the negative temperature coefficient of the drain current, i.e. the current decreases as the crystal temperature increases. There is, therefore, no risk of thermal runaway in class B power stages in contrast to circuits with conventional transistors where, if there is insufficient thermal stabilisation of the standing current, the current rises as the temperature does, the temperature rises as the current does, which ever-increasing circle is only terminated when the transistors give up the ghost. Thanks to the absence of this cumulative effect, V-FETs need no preventative measures against thermal runaway.

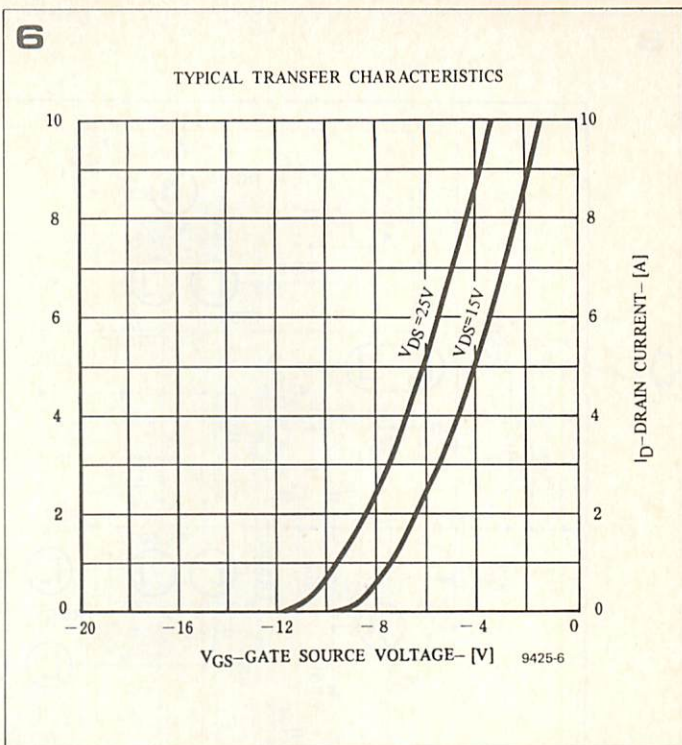
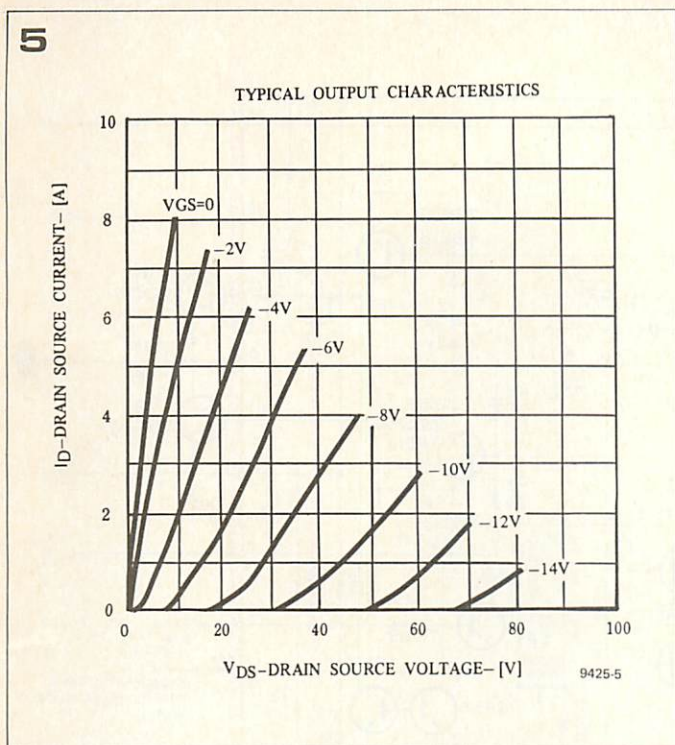

V-FET Circuitry in Practice

Two commercial circuits featuring V-FETs are discussed here, namely the Yamaha B-I type, which is a separate final stage, and the Sony TA 8650, which is an integrated amplifier containing both the pre-amplifier and the output stage. The discussion is confined to the final stages; power supply, filter and protective circuitry are not treated (the Yamaha circuit has in total 39 FETs, 113 transistors, 3 LEDs, 64 diodes and 7 zeners!). Both circuits feature class B output amplifiers, and the dynamic transfer characteristics involve a relatively high quiescent current (400 mA for both). This, in combination with the high supply voltage, results in fairly high quiescent heat dissipation (64 watts per channel in the B-I) in the final stage, but this is no problem for these V-FETs. The tempera-

ture protection in the B-I was intended originally to safeguard other components, for example the expensive computer-quality electrolytic buffer capacitors (rated at 80°C).

A condition not found in conventional transistor circuitry, and only revealed on close inspection of figure 5, is that the drain current will rise out of all proportion if power is supplied to the drain without sufficient bias (positive for n-channels, negative for p-channels) on the gate. Even for short durations, an excessive drain current of this magnitude will endanger not only the V-FET itself, but also the associated series resistors and probably the power unit as well. This condition only occurs at the moment of switching the power on or off. To prevent this, the circuit must be designed such that at switch on, the power is applied first to the pre-

amplifying stages, so enabling the gate bias to build up before power is applied to the final stage; conversely, at switch off, the power is removed from the final stage before the pre-amplifier.

The requirement for a bias voltage of opposite polarity to the drain voltage calls for more than one stabilised (or un-stabilised) power supply; if they were of the same polarity, some of the drain supply which is vital to obtain the full output voltage swing, would be diverted. To avoid this, the driver stage is supplied with a separate power supply.

Yamaha B-I Amplifier

This stereo output amplifier will continuously deliver 160 watts per channel into an 8 Ω load, with the harmonic and intermodulation distortions remaining well below 0.1%. Figure 8 gives the circuit diagram for one channel of the

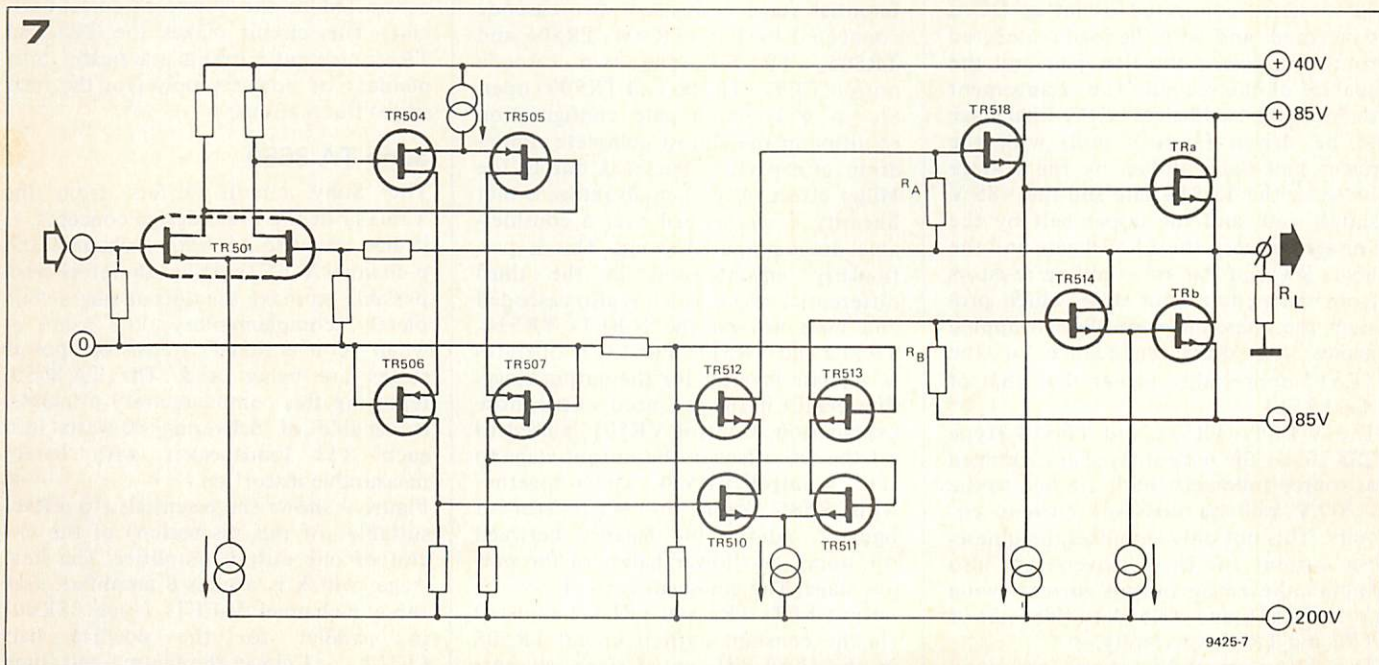

8

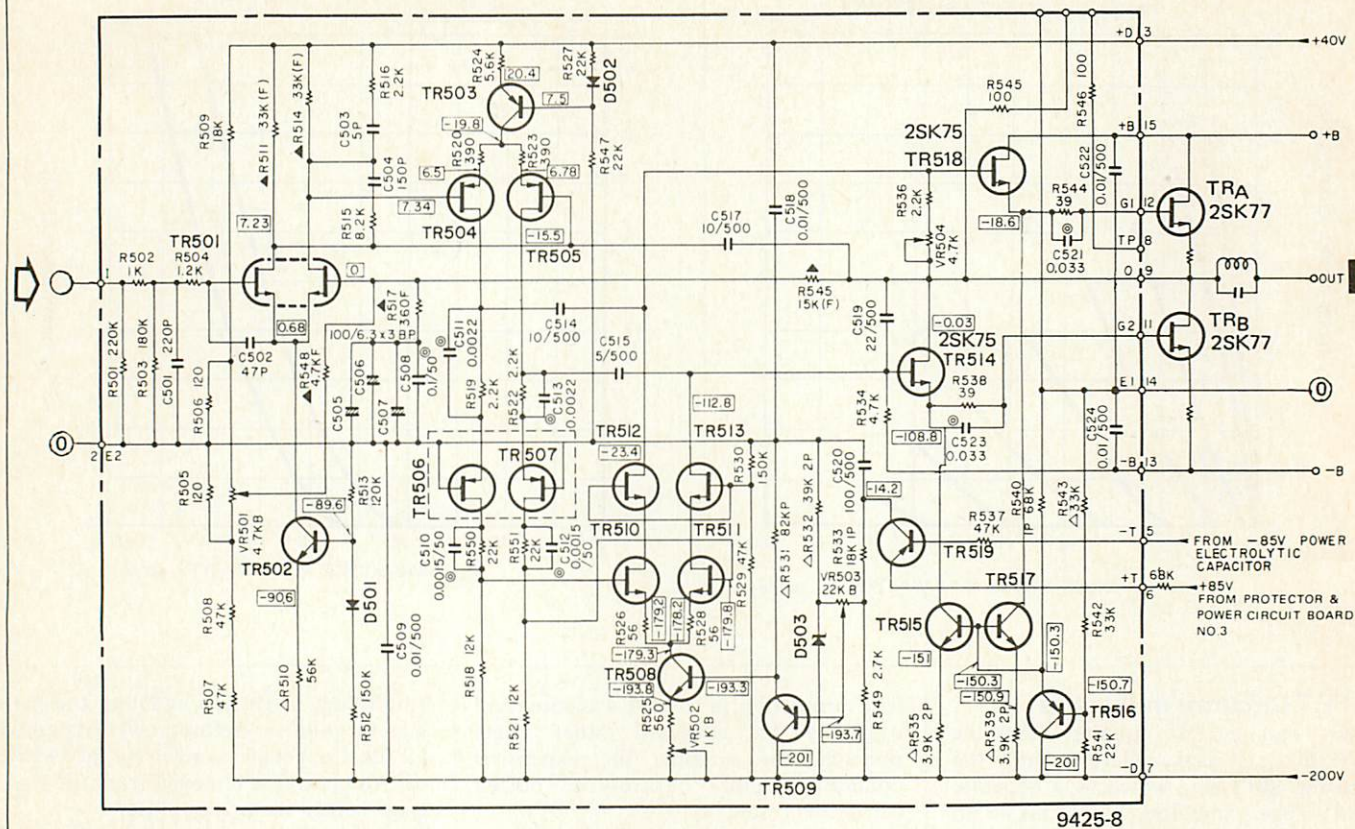

9425-8

output stage, but the principles of operation can best be explained from the stripped diagram in figure 7. The basic design of the circuit may now be seen to bear some resemblance to the once-familiar, single-ended, push-pull power stage featuring two pentodes (EL 86) feeding an 800 Ω loudspeaker. This resemblance is due to the circuit being equipped in all signal handling stages with FETs and the single polarity n-channel V-FETs. In this Yamaha design, the power pair consists of two Darlingtons (TR518, TRa and TR514, TRb) series connected as far as DC is concerned, and with the load connected to the drains of the first pair and the sources of the second. The arrangement requires the two halves of the final stage to be driven in push pull, with the lower half being driven by the voltage between the TR514 gate and the -85 V supply rail, and the upper half by the voltage between the TR518 gate and the load. R_A and R_B are coupling resistors from the penultimate stage which provides the phase inversion. Bootstrapping makes the drain impedance of the TR512 appreciably higher than that of the TR513.

The V-FETs TR518 and TR514 (type 2SK75) in the output stage are arranged as source followers; both are tied to the -200 V rail via constant current circuits. This not only stabilises the quiescent current for these drivers, but also applies the entire output current swing from TR518 and TR514 to the gates of TRa and TRb respectively.

The B-I pre-amplifier stages are com-

posed of three differential amplifiers in cascade with long tail pairs consisting of constant current circuits. The first stage is an n-type dual FET TR501. The input signal is applied to the left hand gate while the right hand gate receives a fraction of the output signal, so providing negative feedback (since the input and output are in antiphase). A dual FET with both elements on the same chip is necessary here since any difference in the DC characteristics of the two would produce an offset voltage at the output. Each half of the second differential stage consists of two cascode connected P-FETs (TR504, TR506 and TR505, TR507). The two cascode output FETs (TR506 and TR507) operate in a common gate configuration resulting in the almost complete elimination of capacitive feedback due to the Miller effect. A further advantage is that linearity is guaranteed over a considerable drain potential swing. This is particularly advantageous in the third differential stage, which is also cascoded and built around the N-FETs TR510, TR512 and TR511, TR513. It operates as a phase inverter for the output stage. The details in figure 8 need a little more explanation. Control VR501 is used to set the DC offset in the output stage to zero. Control VR504, which together with R536 forms the R_A resistor of figure 7, adjusts the balance between the upper and lower halves of the output stage. The quiescent currents for the output FETs TRa and TRb are adjusted via the constant current circuit TR508 in the third differential stage, whereas

the quiescent current for the drivers TR518 and TR514 is stabilised by the constant current circuits TR515 and TR517. Variation of the direct currents through TR510, TR512 and TR511, TR513 causes the TRa and TRb bias to vary, and with it the drain currents. TR508 is fed by a portion of the potential across zener diode D503, and the controls VR502 and VR503 are used to set the quiescent current. The base and emitter of TR519 are strapped via series resistors between the positive and negative power rails (± 85 V): the collector is connected to the quiescent current circuit. This circuit makes the TRa and TRb quiescent currents practically independent of power supply (for the final stage) fluctuations.

Sony TA 8650

The Sony circuit differs from the Yamaha in the basic design concepts, as it has recourse to both n-channel and p-channel V-FETs. It has therefore been possible to make the output stages completely complementary, the same as when conventional transistor power stages are being used. The TA 8650, featuring this complementary principle, is capable of delivering 80 watts into each 8 Ω loudspeaker with barely measurable distortion.

Figure 9 shows the essentials (to a level suitable for this discussion) of the circuit of one output amplifier. The final stage, which is a class B amplifier, uses three n-channel V-FETs (type 2SK60) in parallel for the positive half (T717 . . . T719 in the figure), and three

9

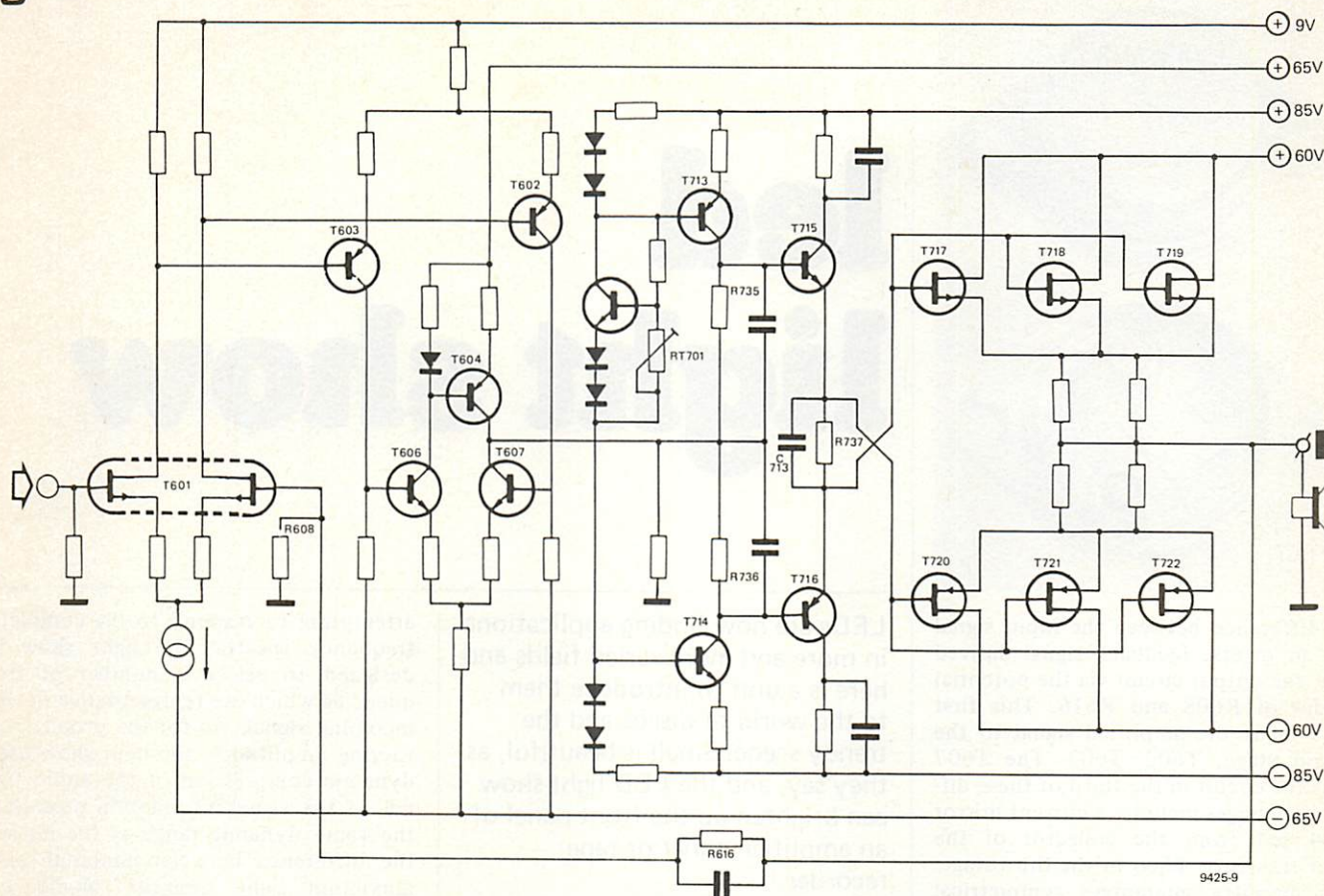

p-channel (type 2SJ18, T720 . . . T722 in the figure) for the negative half. In this configuration they form a complementary source follower feeding the common load. The output stage is powered by ± 60 volts. The parallel connection enables each half of the output stage to dissipate about 190 watts.

The V-FETs in the positive half are biased negatively, while the negative half

Figure 9. Simplified circuit diagram of one channel of the output stage in the Sony TA 8650 integrated amplifier. This stage is a complementary source follower with an inherently low internal impedance, even without negative feedback. The six output FETs must be selected to have a very small spread in the transfer characteristics between them, since the current distribution in the three parallel outputs in each half and in the two halves themselves must be equal.

has a positive bias. In the no signal state, the potential at the junction of the sources is zero. For this reason the respective gates are connected crosswise across resistor R737. The necessity of providing these gate-to-source bias potentials calls for a voltage for the penultimate stage (T711 . . . T716) exceeding that for the final stage. The required supply used in this case is ± 85 volts.

The final stage is driven from a low impedance circuit: the emitter followers of T715 and T716. The sum of the drain-to-source bias potentials for the output FETs appears across the resistor R737. The emitter followers T715 and T716 are powered via the constant current circuits T713 and T714, which are in turn fed via a diode-resistor network from the ± 85 V supply rails. Control RT701 is used to set the potential difference across R737 and thereby the quiescent current for the output stage. This complex circuitry eliminates the effect of power supply fluctuations upon this quiescent current.

N.B. The six output FETs are selected for accurate equality of $|V_{GS}|$ at a constant drain current, which is imperative for uniform current and dissipation distribution among the six power FETs. Unfortunately, this means that a failure of any FET in the final stage will mean replacing all six.

The driver stage T715, T716 is symmetrically controlled via resistors R735 and R736, by the pre-amplifier. The latter is composed of three differential stages, the first of which is designed as an n-type dual FET T601 operating on

Table.		2SK75 n-channel Yamaha	2SK77 n-channel Yamaha	2SK60 n-channel Sony	2SJ18 p-channel Sony
Characteristics of specific V-FETs					
maximum dissipation at 25°C	P_D	20 W	200 W	63 W	63 W
maximum crystal temperature	T_j	150°C	150°C	120°C	120°C
maximum drain-gate voltage	V_{DGO}	200 V	200 V	170 V	-170 V
maximum gate-source voltage	V_{GSO}	-30 V	-40 V	-30 V to -50 V	30 to 50 V
maximum drain current	I_D	0.5 A	20 A	5 A	-5 A
maximum gate current	I_G	10 mA	1 A	0.5 A	-0.5 A
gain	μ	40*	7.5**	4***	4***
slope	S	30 mA/V*	1.5 A/V**	0.25 A/V***	0.25 A/V***
internal resistance	R_i	1k3*	5**	16***	16***

* with $V_{DS} = 80$ V and $I_D = 10$ mA

** with $V_{DS} = 30$ V and $I_D = 2$ A

*** with $|V_{DS}| = 20$ V and $|I_D| = 1$ A

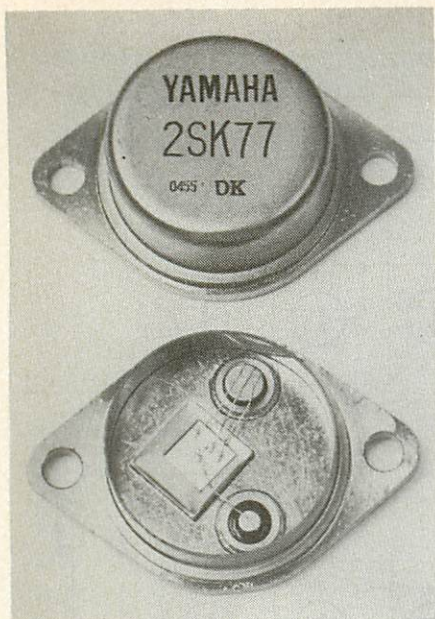

the difference between the input signal and an inverse feedback signal derived from the output circuit via the potential divider of R608 and R616. This first stage feeds the amplified signal to the second stage, T602, T603. The T607 collector circuit in the third of these differential stages includes a current mirror T604 fed from the collector of the other transistor T606 in the third stage. This circuitry guarantees symmetrical control of the driver and hence the output stage.

Conclusion

The object of this article has been to provide our readers with some insight into the properties and possible applications of these new beasts. The high quality of the commercial circuitry described goes without question, especially as regards the absence of cross-over distortion (although this has been achieved at the cost of a quiescent dissipation that equals the maximum output power of some small conventional power amplifiers!)

Despite the impressive figures the relationship between quality and price is not in all cases more favourable than that for equipment using conventional bipolar transistors with a few FETs thrown in. In this respect, it is worth noting that Sony offers two interesting alternatives in the shape of amplifiers TA 4650 and TA 5650, which are considerably lower in price and have an output power only 2 or 3 dB down.

led light show

LEDs are now finding applications in more and more varied fields and here is a unit to introduce them to the world of discos and the trendy scene. Small is beautiful, as they say, and the LED light show can brighten up the front panel of an amplifier, tuner or tape recorder.

The light show described here is fairly inexpensive and simple to build, and is distinguishable from conventional light shows, not only by its use of LEDs (light-emitting diodes), but also by its filtering system and the lack of a (hazardous) high voltage. It is intended as a decorative addition to an audio set-up by installing the LED light show in the front panel (say) of the amplifier or tuner, perhaps. This will give an attractive (even if somewhat miniaturised) visual rendering of the music; the display is enhanced by the use of three different colours.

Design philosophy

Consider the requirements of a light show: its task is to accentuate audio information with a visual display. The audio information will be from various sources (e.g. musical instruments), each of which has a characteristic frequency spectrum and amplitude. Rather than

attempting to respond to the complete frequency spectra, the light show is designed to select a number of frequencies which are representative of the incoming signal. As for the problem of varying amplitudes, the light show uses dynamic compression of the audio signal. If the visual information possessed the same dynamic range as the music, the difference between minimum and maximum light intensity would be annoying. Another consideration is that visual selectivity is much less than acoustic selectivity, so the frequency bands chosen for visual representation are deliberately restricted. It is generally accepted that audio frequencies are divided into three groups for display: low, medium and high. However the boundaries which lie between these groups are not so well defined. Many applications leave overlaps between these groups, but in this case it has been found that leaving gaps gives a better solution (see figure 1).

Figure 2 is a block diagram of the light show. The compressor which is used to reduce the dynamic range of the audio signal can be of a much lower quality than one for use in an audio circuit. The only restriction is that the harmonic distortion produced by (say) the middle channel should not be visible on the high channel. The characteristic of the compressor should not be such as to amplify noise or hum which would then be displayed during quieter passages. Even so, the visual effect is still impaired by peaks, but since the response of the amplifiers A1 . . . A3 is unimportant, they are designed to limit on a fairly low input signal to mask non-linearities in the compressor. The filters feeding A1 . . . A3 are low-pass, band-pass and high-pass, respectively. In the circuit described here, use is made of double-T filters. This facilitates the early-limiting design of the amplifiers. The double-T filters are of simple design and give good selectivity, but they have the disadvantage of being peaked. This can be remedied by damping the filters, bearing in mind

the restriction, still, that the frequency bands must not overlap.

In designing the amplifiers A1 . . . A3 it must be remembered that the programme material upon which this type of device is most commonly used contains a predominance of the low frequencies. The gains of A1 . . . A3 must therefore be such as to overcome this disparity.

The point at which the light show is connected into the audio circuit can vary between a pre-amplifier and a 100 W output amplifier. The compressor should not only be resistant to the very high levels which may well occur, but must also continue to function normally when they do. In addition, the input impedance must be sufficiently high so that the circuit to which it is connected is not loaded by it.

In most light shows, the loads of the amplifiers A1 . . . A3 are driven by triacs or thyristors, either via an isolating transformer or an optocoupler. No relationship between light intensity and amplitude can be obtained, since the condition controlling the lamp state is binary, i.e. the lamp is on if the amplifier output is above the trigger voltage, and off if it is not. How the relationship is obtained in this particular design is explained shortly.

The Circuit

Figure 3 gives the circuit diagram for the light show. The compressor is formed by the circuit around IC1 (741), which is connected as a non-inverting amplifier whose gain may be varied from 20 dB to 60 dB by means of P1. When the emitter voltage of T1 becomes greater than +6.5 V D1 and D2 start conducting, thus reducing the input signal and hence the output signal until equilibrium is restored. Since the time constants in the control circuit are fairly large, it takes some time for equilibrium to be restored. Asymmetrical compressors require a fairly slow control rate because otherwise motor-boating (low frequency oscillations) could easily occur.

The output of the compressor stage is fed to the three double-T filters, as shown. These filters have enough output current to drive the LEDs through 220 Ω resistors, allowing the relationship between amplitude and light intensity to be retained.

Construction and Operating

The circuit should preferably be given a metal housing, and a screened lead should be used between the input socket and the compressor input, with the screening connected to the housing at the input socket. The connections from the filters to the LEDs can be made with ordinary connecting wire.

After construction and careful inspection of the completed circuit, the light show is set up in the following way: adjust P1 to give maximum gain (slider against R4) and then P2 . . . P4 (sliders against C5). Connect the compressor

input to the loudspeaker or to the pre-amplifier output so that the audio signal is fed to the light show (it is better to avoid classical and choral music while setting up). Now adjust P1 . . . P4 so that the light display gives the best (subjective) match with the music. The setting is a matter of personal taste and it may be found that taste demands different settings for different types of music. If instabilities occur in any of the channels, a lower value must be selected for the corresponding resistor, R13, R19 or R25.

A printed circuit board and component layout are shown in figure 4.

Figure 1. Two ways of dividing frequencies into groups or channels. The light show gives better optical effects if the second method of leaving gaps between the groups is employed.

Figure 2. Block diagram of the light show which at this level of detail appears the same as a conventional one, consisting of compressor, channel filters and channel amplifiers.

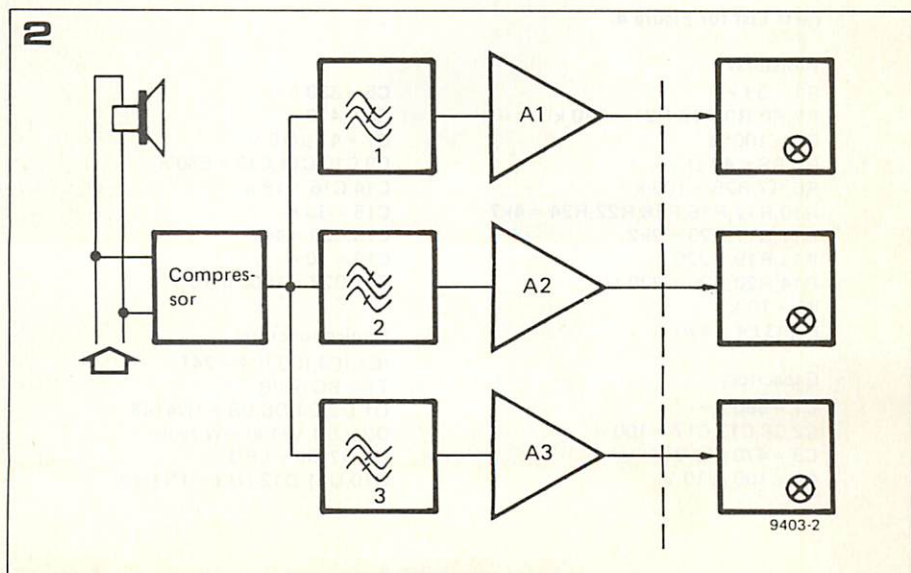
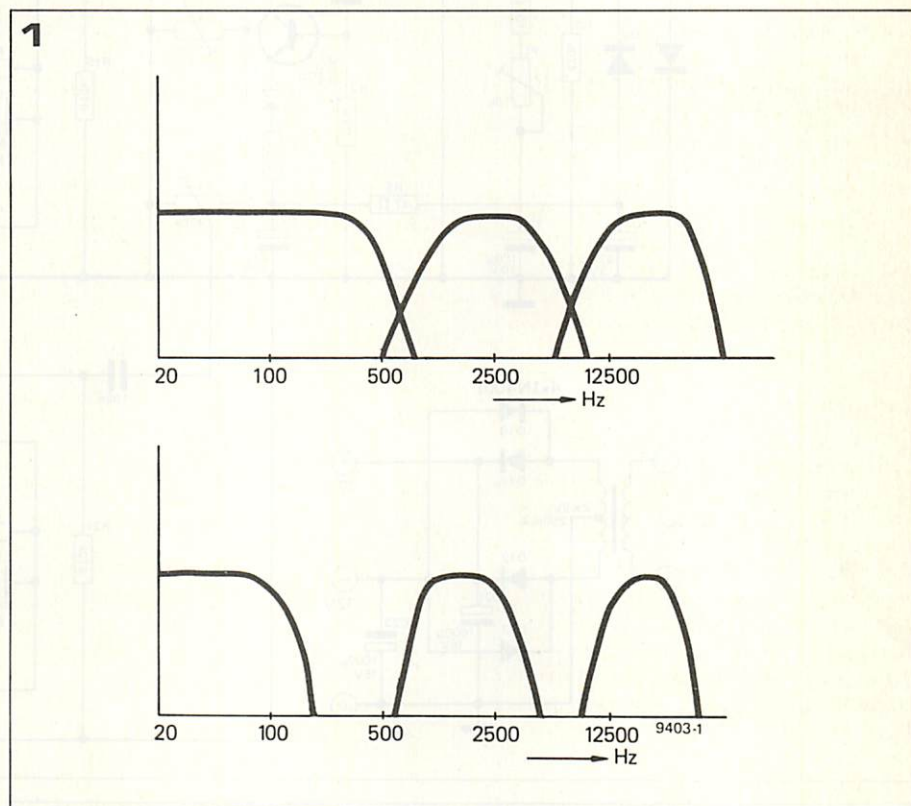

3

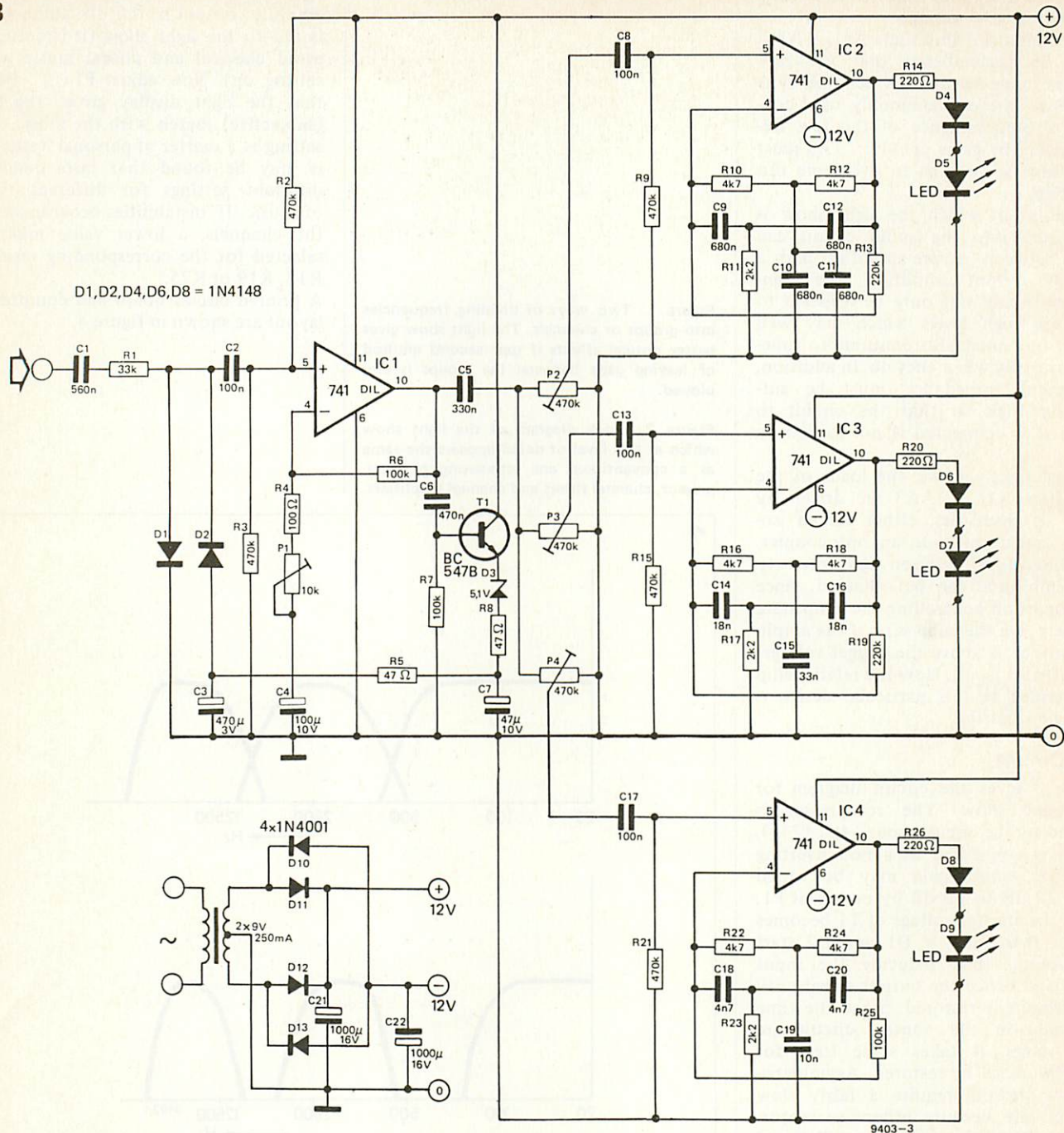

Parts List for Figure 4.

Resistors:

R1 = 33 k
 R2, R3, R9, R15, R21 = 470 k
 R4 = 100 Ω
 R5, R8 = 47 Ω
 R6, R7, R25 = 100 k
 R10, R12, R16, R18, R22, R24 = 4k7
 R11, R17, R23 = 2k2
 R13, R19 = 220 k
 R14, R20, R26 = 220 Ω
 P1 = 10 k
 P2, P3, P4 = 470 k

Capacitors:

C1 = 560 n
 C2, C8, C13, C17 = 100 n
 C3 = 470 μ /3 V
 C4 = 100 μ /10 V

C5 = 330 n
 C6 = 470 n
 C7 = 47 μ /10 V
 C9, C10, C11, C12 = 680 n
 C14, C16 = 18 n
 C15 = 33 n
 C18, C20 = 4n7
 C19 = 10 n
 C21, C22 = 1000 μ /16 V

Semiconductors:

IC1, IC2, IC3, IC4 = 741
 T1 = BC 547B
 D1, D2, D4, D6, D8 = 1N4148
 D3 = 5.1 V/400 mW zener
 D5, D7, D9 = LED
 D10, D11, D12, D13 = 1N4001

Figure 3. The LED light show makes use of the cheap 741. Channel separation is achieved by means of damped double-T filters. One advantage of this filtering method is that when connected to an FM receiver the stereo pilot tone gives no trouble.

Figure 4. Printed circuit board (EPS 9403) and component layout for the light show circuit of figure 3. The printed circuit has been designed so that either TO-5 or dual-in-line packages may be used.

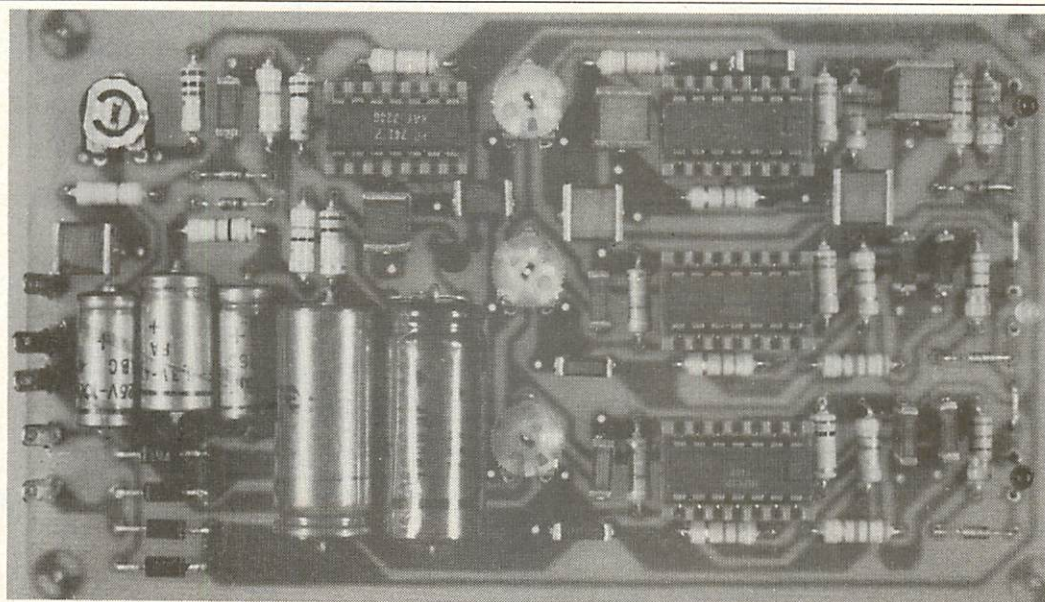
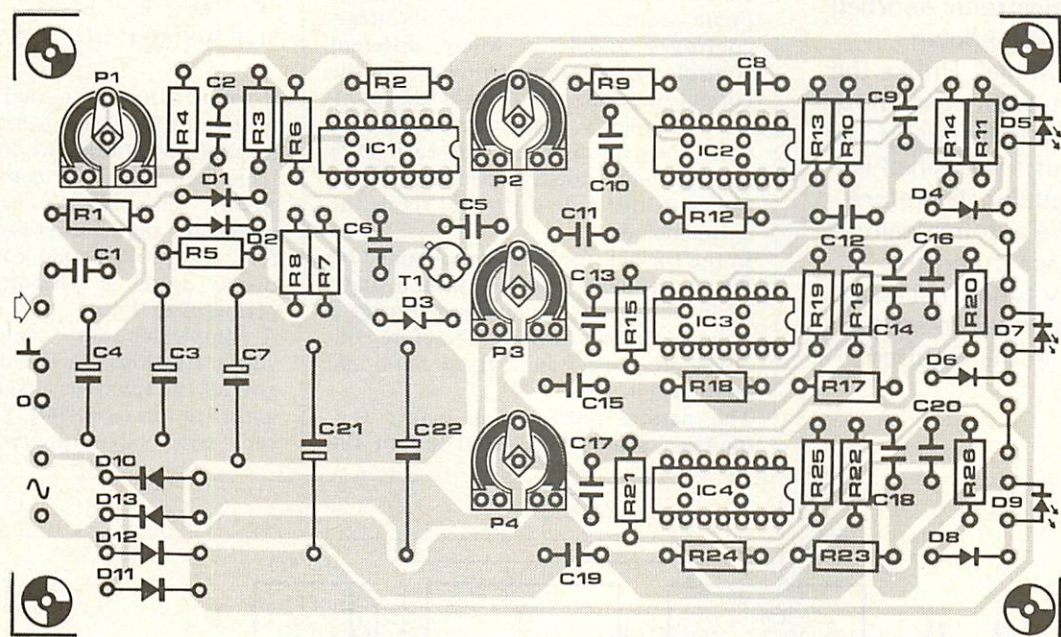
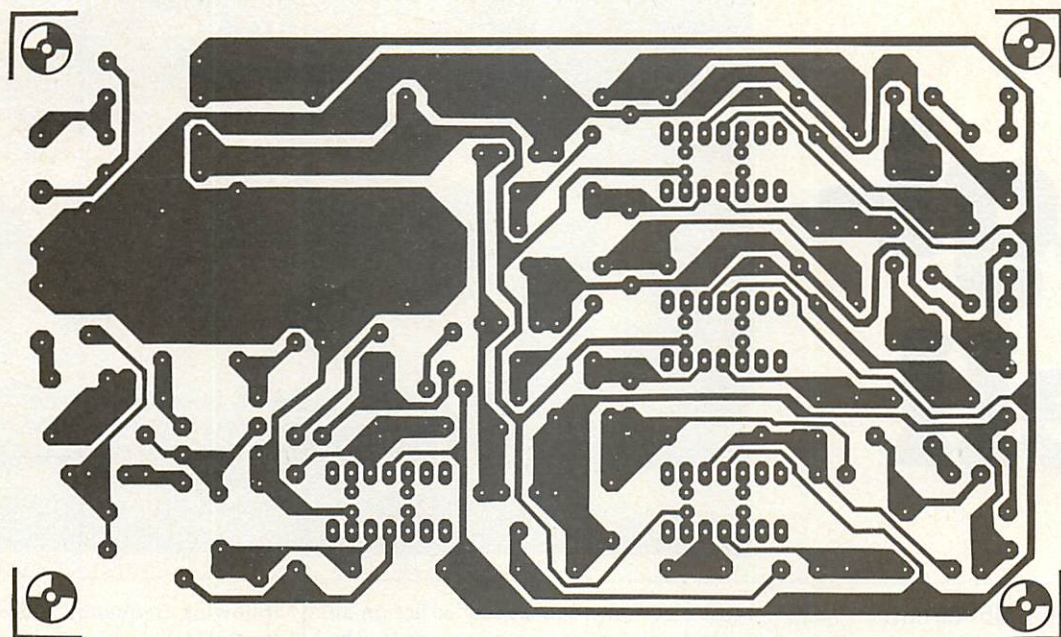

R. Janssen

digibell

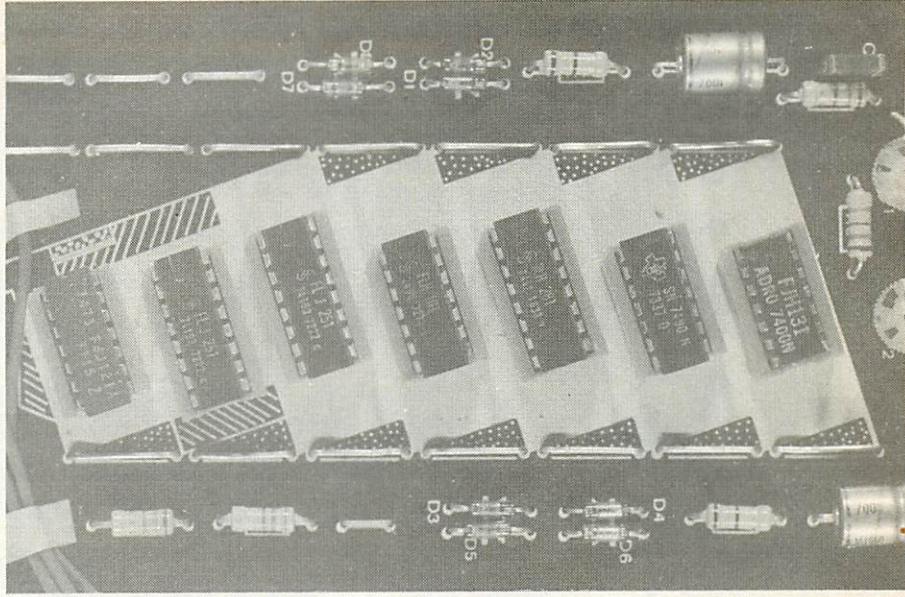

Like the 'Big Ben 95' circuit published in Elektor 2 this is a design for an electronic doorbell that plays the well-known 'Westminster Chime'. Unlike the Big Ben circuit, where each note had to be tuned individually, the programming of the Digibell is carried out digitally. Therefore all the notes are automatically in tune with each other, this means the only tuning necessary is a single adjustment to set the entire melody in the required key.

Most electronic chimes rely either on an individual oscillator for each note, the oscillators being switched in the appropriate sequence, or else use a voltage-controlled oscillator where different control voltages are switched in the correct sequence to control the oscillator frequency. The disadvantage of both these systems is that each note must be individually tuned, and if the tuning of one note drifts this spoils the entire melody.

In the Digibell the notes are obtained by digital frequency division from a single frequency. This is accomplished using a programmable divider. Therefore the notes are always in a fixed harmonic relationship.

The natural notes in an octave (i.e. omitting sharps and flats) are in the

following frequency ratios to the fundamental (C):

C	D	E	F	G	A	B	c
1/1	9/8	5/4	4/3	3/2	5/3	15/8	2/1

It follows that the period of each note, relative to the fundamental, is the reciprocal of the appropriate frequency ratio. Using period rather than frequency will greatly simplify the calculations required for the counter programs. Therefore, the programmed count for a particular note is proportional to the period of that note.

A simple counter cannot deal with vulgar fractions, so the next step is to give all the fractions a common denominator (in this case 180). The numerators can now be expressed as integral

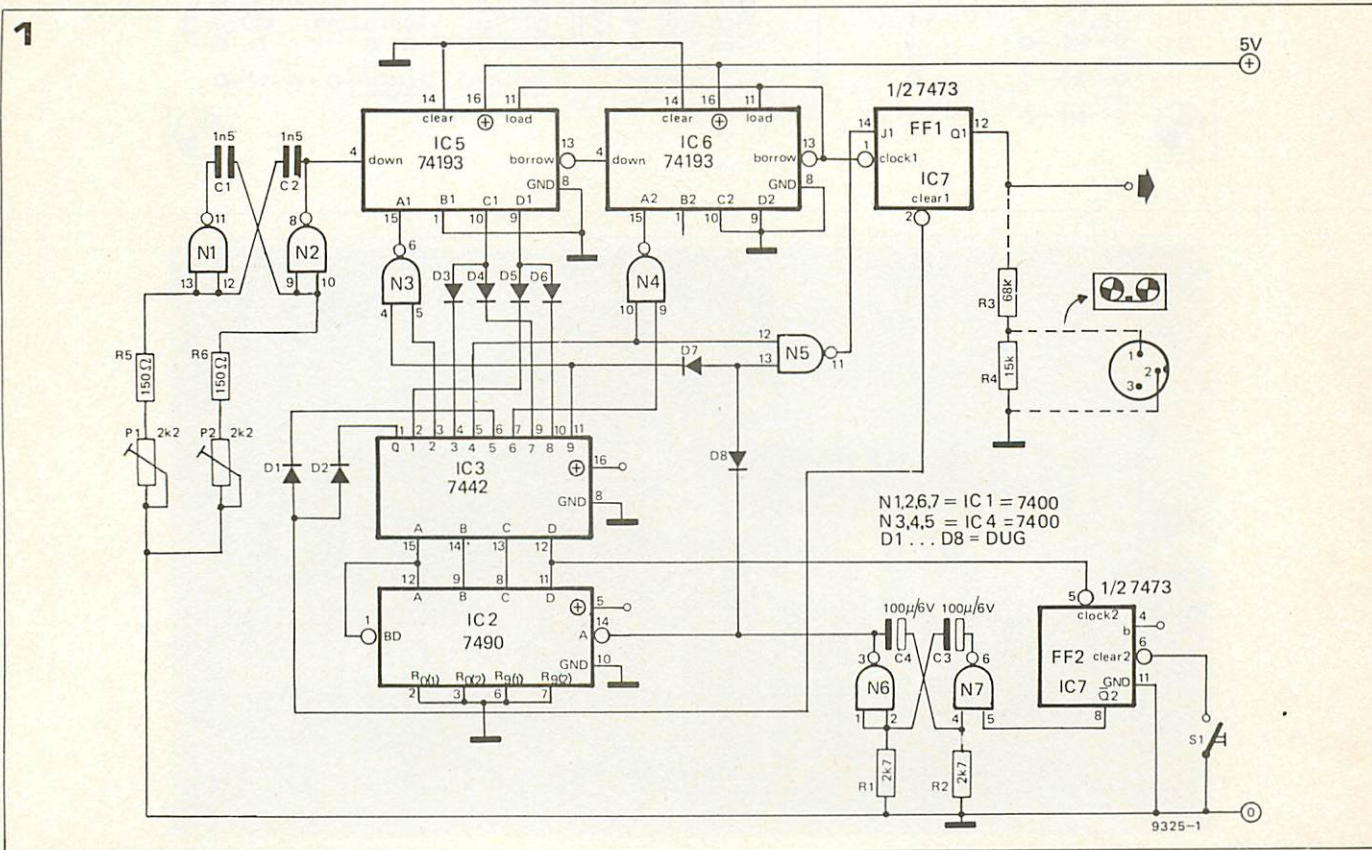

numbers and converted into binary code (since this is what the counter will be programmed with).

This results in the following table:

Note	Decimal	Binary
c'	90	01011010
b	96	01100000
a	108	01101100
g	120	01111000
f	135	10000111
e	144	10010000
d	160	10100000
c	180	10110100
B	192	11000000
A	216	11011000
G	240	11110000

It is evident, from the above table, that if the programmable counter is set to count to 90 and is fed with a clock frequency 90 times that of c' then the output frequency will be c'. If it is set to count to 180 and is fed with the same clock frequency then the output will be c, one octave below c'. This is how each note is synthesised from a single clock frequency. Since each note bears a fixed frequency ratio to all the other notes it is obvious that the only tuning necessary is to adjust the clock frequency until the melody is in the required key.

The Westminster Chime uses only the notes G, c, d and e in the sequence e, c, d, G, G,d, e, c, so at first sight it appears that division ratios of 240, 180, 160 and 144 are required. By coincidence however, it happens that these numbers are all divisible by four, so the division ratios can be reduced to 60, 45, 40 and 36. This means that the programmable counter can be of shorter length, and that the programming is simplified.

In addition to getting the notes right it is also important to achieve the correct tempo. The first three notes each have a duration of one crotchet, while the fourth note has a duration of one minim (two crotchets). This is followed by a rest of one minim duration. The fifth, sixth and seventh notes are each of one crotchet duration, while the final note has a duration of one minim. The total duration of the tune is thus 11 crotchets. When designing the circuit that performs the sequencing this must be taken into account.

The Circuit

The circuit of the Digibell is given in figure 1. The clock pulse generator consists of two NAND gates N1 and N2. They are connected as an astable multivibrator whose frequency and duty-cycle can be adjusted with P1 and P2. The programmable counter consists of two presettable up-down counters type 74193. These are connected to count down from a preset number to zero, the number being loaded into the data inputs A1-D1, A2-D2 before the start of each count. The operational sequence for the presettable counter is as follows:

initially the borrow output of IC6 is low. This takes the load inputs of IC5 and IC6 low, so the data on the inputs A1-D2 is loaded and the count commences. During the count the borrow output is high, but when the count reaches zero it again goes low, the data is reloaded, the count recommences and so on.

Since the borrow output is low for only a small proportion of each count the output waveform is very asymmetric and is not suitable for use as an audio

tone. For this reason FF1 is connected to the borrow output and produces a square wave with a 1:1 mark-space ratio (50% duty-cycle) at half the frequency (i.e. one octave below) the borrow output.

To produce the Westminster Chime melody the programming numbers corresponding to the four required notes must be fed to the data inputs of the presettable counter in the correct sequence. This is controlled by a second counter (type 7490), and a 7442 BCD-to-decimal decoder.

When the bell-push S1 is pressed the Q output of FF2 goes high, enabling the astable multivibrator N6/N7, which feeds clock pulses at about a 2 Hz rate into the A input of IC2. These are counted by the 7490 and the BCD outputs of the 7490 are decoded by the 7442. The 10 outputs of the 7442 go low in turn, at each step feeding a different number into the data inputs of IC5 and IC6 via the encoder comprising N3, N4 and D3 to D6. (Note that the 7442 has active low outputs, i.e. outputs are normally high and go low when enabled by the appropriate input code). On the tenth clock pulse the D output of IC2 goes low, clocking FF2 back to its original state (Q output low) until the next time the bellpush is pressed. The correct tempo of the melody is achieved in the following manner. If each note were sustained until the next clock pulse occurred then the notes would simply slur into one another without a pause. This is avoided, and the rest in the middle of the tune is included, by means of N5 and diodes D1, D2, D7 and D8.

At the start of the sequence the 0 output of IC3 is low so FF1 is held in the

Figure 1. Circuit diagram for Digibell.

Figure 2. Truth table for the counter program.

Figure 3. Timing Diagram which shows sequencing of the Digibell.

COUNT	IC3 OUTPUTS 0 1 2 3 4 5 6 7 8 9	IC5, IC6 DATA INPUTS								DECIMAL	NOTE
		BINARY									
		D2	C2	B2	A2	D1	C1	B1	A1		
0	0111111111	0	0	1	0	1	1	0	0	44*	-
1	1011111111	0	0	1	0	0	1	0	0	36	e
2	1101111111	0	0	1	0	1	1	0	1	45	c
3	1110111111	0	0	1	0	1	0	0	0	40	d
4	1111011111	0	0	1	1	1	1	0	0	60	G
5	1111101111	0	0	1	0	1	1	0	0	44*	-
6	1111110111	0	0	1	1	1	1	0	0	60	G
7	1111111011	0	0	1	0	1	0	0	0	40	d
8	1111111101	0	0	1	0	0	1	0	0	36	e
9	1111111110	0	0	1	0	1	1	0	1	45	c

* Not important as output of FF1 disabled during rest

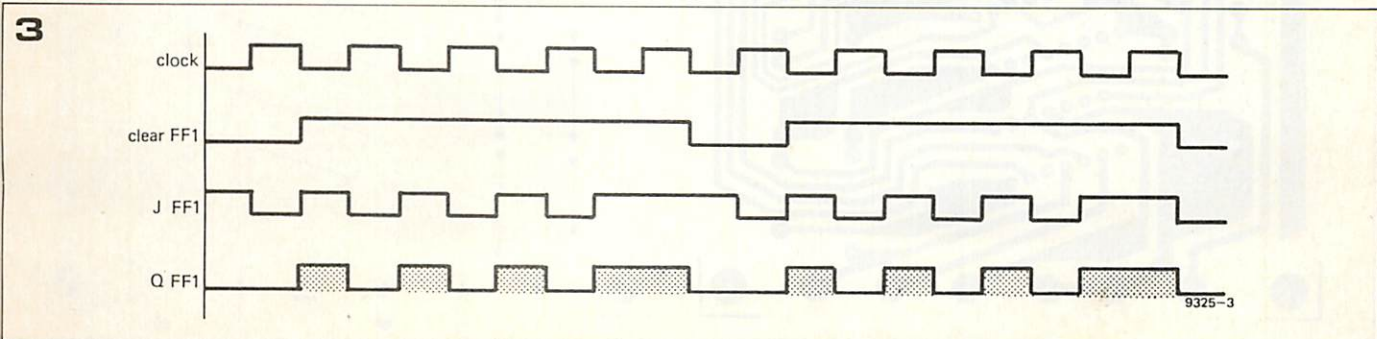

clear state and there is no output. During notes 1, 2 and 3, pin 12 of N5 is high and pin 13 is switched alternately high and low by the output of N6. The output of N5 thus gates the J input of FF1 so that there is an output only when the clock pulse (output of N6) is low. The first three notes thus have a duration of half a clock pulse.

On the fourth note pin 12 of N5 goes low, so the output remains high whatever N6 does. The J input of FF1 is thus high and the fourth note has a duration of one clock pulse. On the fifth step output 5 of the 7442 goes low, so FF1 is held in the clear state via D1 and there is no output. This is the rest.

The next three notes are all of half a clock pulse duration, but on the final note pin 13 of N5 is held low, via D7, the output of N5 holds the J input of FF1 high and this note has a duration of one clock pulse.

To make the sequence of operations clearer, a truth table for the counter programming and a timing diagram for the sequencing are given in figures 2 and 3. Figure 4 shows a p.c. board and component layout for the Digibell. For use as a doorbell the output of FF1 must be amplified to a level suitable to drive a loudspeaker. The output

Parts list for figure 1

Resistors:

R1,R2 = 2k7
R3 = 68 k
R4 = 15 k
R5,R6 = 150 Ω
P1,P2 = 2k2 adjustable

Capacitors:

C1,C2 = 1n5
C3,C4 = 100 μ /6 V

Semi-conductors:

D1 ... D8 = DUG
IC1, IC4 = 7400
IC2 = 7490
IC3 = 7442
IC5,IC6 = 74193
IC7 = 7473
S1 = Push button switch

Figure 4. p.c. board (EPS 9325) and component layout.

Figure 5. A possible amplifier for use with the Digibell.

5

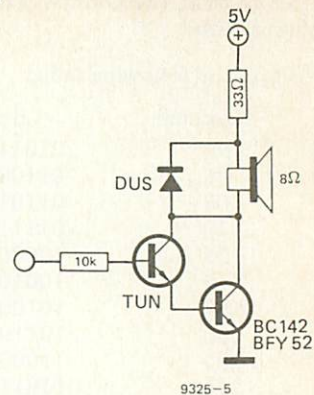

attenuator R3/R4 may or may not be required, depending on the sensitivity of the amplifier used, or they may be replaced by a potentiometer of between 10 k and 100 k to provide a volume control.

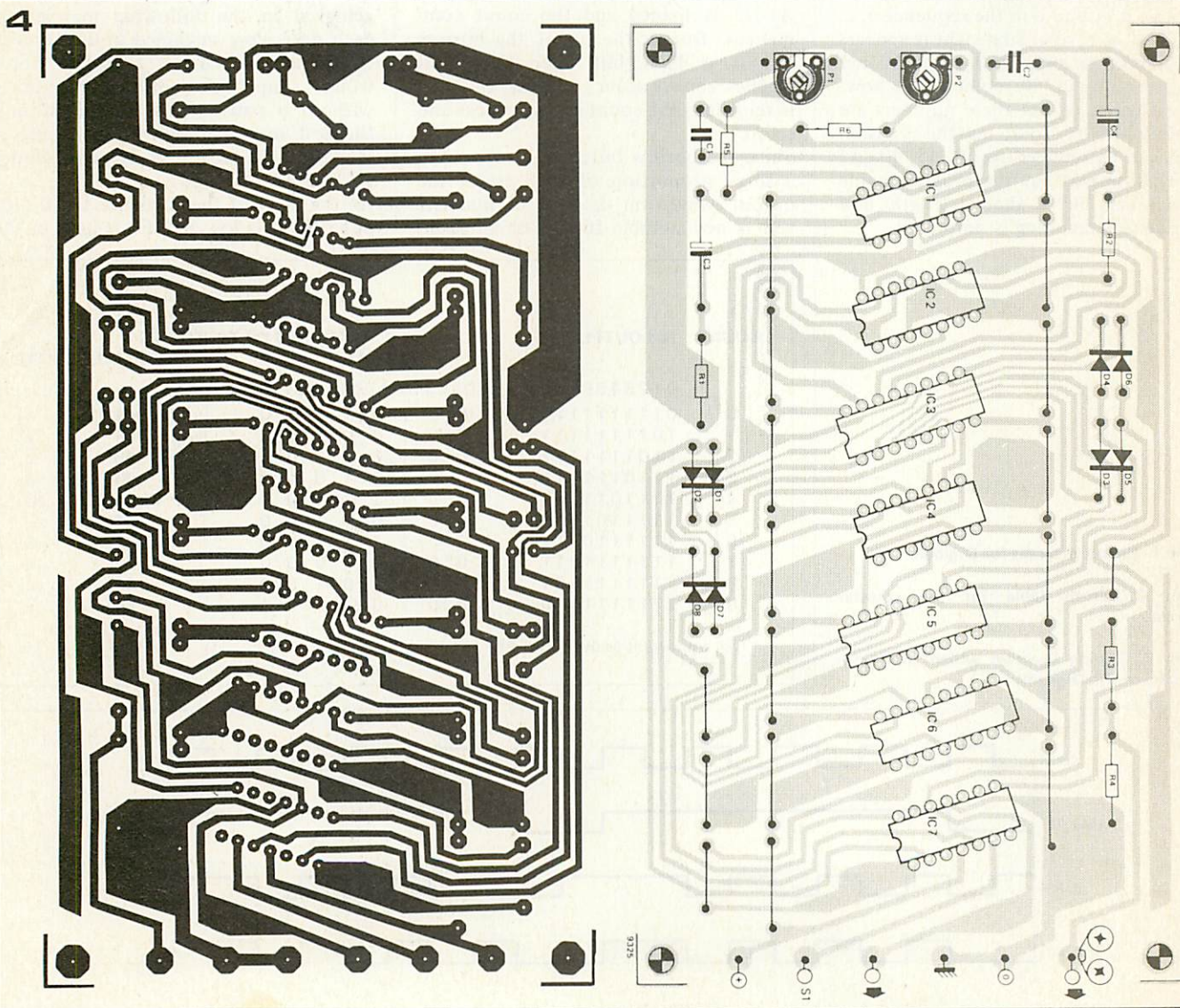

MARKET

Divide-by-Four Gigahertz counter from Motorola Semiconductors

Communications engineers will be interested in a new integrated circuit from Motorola known as the MC1699 divide-by-four gigahertz counter.

This is a very high speed device for prescaler applications. The clock input requires an a.c.-coupled driving signal of 160 mVpp amplitude (typical). A sine-wave signal is acceptable for frequencies from 50 MHz to 1.2 GHz. Below 50 MHz wave-shaping is recommended. With pulses which have good rise and fall times (in the order of 1 to 2 nsec), the MC1699 has no lower limit on clock frequency. The clock toggles two divide-by-two stages and the complementary outputs (50% duty cycle) are taken from the second stage.

DIVIDE-BY-FOUR GIGAHERTZ COUNTER

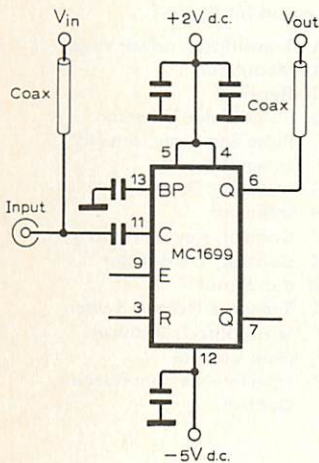

COUNT FREQUENCY
TEST CIRCUIT

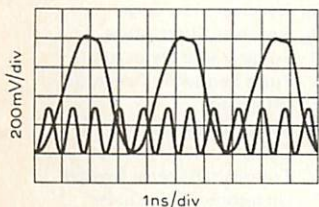

OPERATING
CHARACTERISTICS
AT 1.2GHz

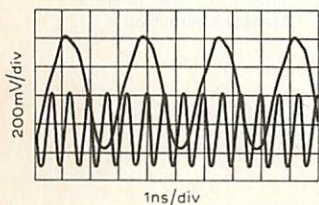

OPERATING
CHARACTERISTICS
AT 1.5GHz

The MC1699 includes clock enable and reset inputs both compatible with MECL111 voltage levels. The reset operates only when either the clock or the enable is high and provides increased flexibility for counter and time measurement requirements.

The MC1699 is supplied in a flat ceramic package (F Suffix) for compact assemblies and soon will be available also in a DIL ceramic package for easier mounting.

Motorola B. V.
Emmalaan 41, UTRECHT,
The Netherlands

Microwave Power Transistor

Motorola have just announced a state-of-the-art microwave power transistor, the MRF 835. Characteristics specified at 870 MHz using a 12.5 V DC supply are 15 watts output power, 7.0 dB minimum gain and 50% efficiency.

High gain, high power transistors actually consist of a few hundred transistors in parallel. Current to and from these doped regions is carried by metal conductor stripes deposited on top of the die. These stripes must withstand high current densities. In order to achieve good performance at frequencies as high as 950 MHz Motorola make these 'fingers' extremely narrow. However, in conventional designs, aluminium in narrow lines with high current density migrates, thus causing early failure of the device. In the MRF 835 Motorola have overcome these problems by using a gold metallisation system - because the automatic weight of gold is higher than that of aluminium the migration is greatly reduced and the mean-time-between-failure figure is increased 1,000 to 10,000 times.

The MRF 835 is designed specifically for mobile radio applications at frequencies around 900 MHz and incorporates Motorola's 'Controlled Q' built-in matching network which ensures broadband performance.

Motorola B. V.
Emmalaan 41, UTRECHT
The Netherlands

High current digital clock

AMI Microsystems have introduced a new digital clock module which offers a high current output for direct drive of large LED displays as used in clocks, clock radios, and timers/ elapsed-time counters. Designated S1998A, it provides

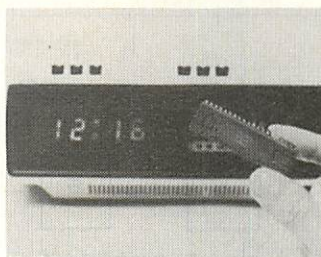

more than 8 mA per segment, and can be directly substituted for the industry-standard S1998 in high current, low voltage display applications. The 1998A directly interfaces with both solid-state LED displays, and fluorescent/gas discharge displays. The time-keeping function operates on 50 Hz or 60 Hz inputs, and the display output is available with either AM/PM indicators or 24-hour format options. Other outputs include timed radio turn-off, and radio/alarm enable. A power failure indication is provided to inform the user of an incorrect time display. The S1998A also incorporates a presettable 59-minute count-down timer, an alarm with snooze feature, and unlimited snooze repeat.

Clock input noise rejection circuitry eliminates the need for external filtering of the line frequency input. Reset-to-zero circuitry is included for timer/ elapsed time applications, and blanking control also allows the use of several circuits in parallel with a single display for multiple event timing.

The S1998A, which can operate from power supplies between 8 and 26 V, is pin compatible with the S1998, MM5316, EA5316, and FC13817.

AMI Microsystems Ltd.
108A Commercial Road,
Swindon, Wiltshire, England.

Low profile IC socket

Molex have announced the availability of a range of low profile dual-in-line integrated circuit sockets.

Designated the 6197 series, they consist of a 94 V-0 black polyester polarized housing containing either 14 or 16 discrete pin sockets. These utilize side-wiping contacts, which offer significantly

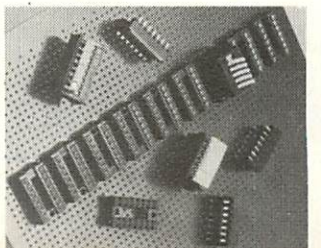

greater contact surface than the more conventional edge-bearing type. Contacts are of 60Cu 30Zn cartridge brass, and are available in a variety of finishes including tin plate and gold over nickel. Optional contact materials such as phosphor bronze, and alternative special contact finishes, are also available.

Molex Electronics Ltd.,
1 Holder Road, Aldershot,
Hants GU12 4RH.

Multi-family logic probe

Designed to simplify and speed logic circuit testing, this new \$125 model 545A logic probe from Hewlett-Packard indicates digital states and pulses in both high level (CMOS) logic and low level (TTL) logic. An unambiguous single lamp indicator displays high or low level or detects bad level and open circuit conditions. CMOS and TTL operation is selected with a slide switch. CMOS logic threshold levels are variable and set automatically. Now, nearly all positive logic up to +18 volts dc can be sensed using one probe. These families include: TTL, DTL, RTL, CMOS, HTL, HiNIL, NMOS and MOS.

Another feature of the model 545A is a built-in pulse memory which, along with the display, will catch intermittent pulses. When

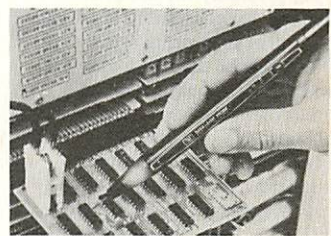

a logic change occurs, the indicator lamp turns on and remains lighted until the memory is reset.

Pulse stretching is provided so the operator can see fast pulses as short as 10 nanoseconds with the blinking display. Pulse trains to a frequency of 80 MHz are detected in TTL logic, and to 40 MHz in CMOS logic.

Light and rugged, this hand-held model 545A is fully protected against voltage overload. Power required for TTL operation is 4.5 to 15 volts DC, and for CMOS operation is 3 to 18 volts DC. To use the 545A, the operator connects the probe to the circuit's highest level power supply, sets the slide switch to the appropriate logic family, then probes. Open, pulsing, or stuck nodes and gates are quickly detected.

Hewlett Packard, P.O. Box 349,
CH-1217 Meyrin 1 Geneva,
Switzerland

MARKET

Synthesized signal generator

A new synthesized microwave signal generator, Model 8672A from Hewlett-Packard, covers the range 2 to 18 GHz in one solidstate package only 5 1/4" high. With AM/FM and calibrated output usually associated only with signal generators, 8672A also offers the resolution, spectral purity, stability, and programmability of a high-quality synthesizer. Yet its price is well below equipment commonly used in the past to synthesize microwave signals over comparable ranges. A companion instrument, Model 8671A, covers the range 2 to 6 GHz with FM capability only. Both machines are programmable via the HP Interface Bus. Frequency resolution of the 8672A is 1 kHz in the range from 2 to 6.2 GHz, 2 kHz from 6.2 to 12.4 GHz, and 3 kHz above 12.4. Frequency stability is better than ± 5 in 10^{10} parts per day with the internal frequency standard. Spurious signals are more than 70 dB below the carrier at 6 GHz, more than 60 dB down at 18 GHz. Single-sideband phase noise (in a 1-Hz bandwidth) is more than 78 dBc 1 kHz away from a 6-GHz carrier; 100 kHz away, it's -109 dBc. Calibrated output is from +3 to -120 dBm; attenuation is displayed digitally on an LED readout. In overrange, power levels to +10 dBm are typically available below 6.2 GHz, and to +7 dBm at other frequencies. Power can be internally leveled ± 1.25 dB; connections are provided for leveling externally. Modulation signals are externally supplied but internally monitored. AM 3-dB bandwidth is more than 500 kHz at 6 GHz, more than 100 kHz at 18 GHz. AM depth is selectable in two ranges, 30% per volt and 100% per volt, controlled linearly by varying the input signal. FM input rates to 10 MHz are possible up to peak deviations of 10 MHz. Six

ranges of peak deviation are offered, from 30 kHz per volt to 10 MHz per volt of input. Peak deviation may also be displayed on the front panel meter. FM and AM are entirely independent, and may be applied simultaneously. Without exception, all front panel controls are remotely programmable. Frequency changes typically settle within 1 kHz of command in less than 15 milliseconds. RF output can be programmed over its full amplitude range in 1-dB steps as well as OFF (without unpowering the instrument). AM or FM, or both at once, may be remotely applied.

The lower-priced 8671A has the same spectral-purity, resolution, and switching-speed performance as the 8672A; it is likewise totally programmable via the HP-IB, and it has the same FM specs. 8671A lacks AM capability, output levelling, and calibrated output attenuator. Its frequency range is 2 to 6.2 GHz. First customer deliveries are expected in June.

*Hewlett Packard
7, rue du Bois-du-Lan,
P.O. Box 349,
CH-1217 Meyrin 1 Geneva,
Switzerland*

Precision Voltage References

Analog Devices Ltd., announce the availability of a new ± 10 V and -10 V precision voltage reference, together with an improved performance version of the recently introduced 10 V reference. Designated AD2702, AD2701 and AD2700/L, respectively, the new units are ideally suitable for application in 12-bit A/D and D/A converter circuits, combining high performance thin-film technology, automatic laser trimming and volume hybrid assembly, with small size and hermetically sealed 3-terminal terminal references. Designed to now operate over the extended temperature range of -55°C to 125°C , AD2700/L

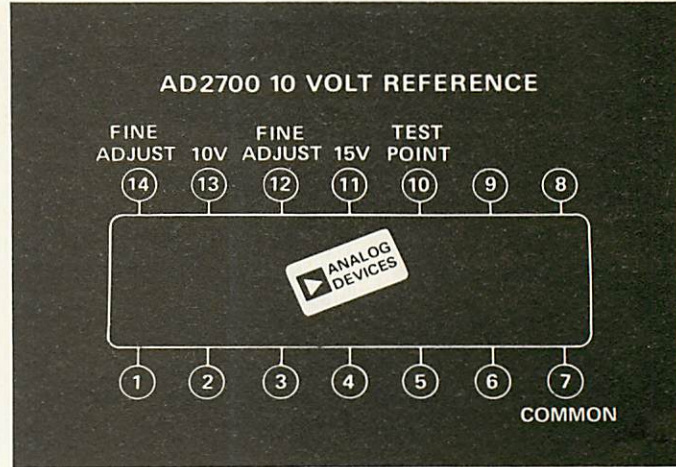

ANALOG DEVICES' AD2700 10.000 $\pm 0.001\text{V}$ REFERENCE FEATURES LOW PRICE AND $\pm 0.03\%$ MAXIMUM OUTPUT ERROR AT $+70^{\circ}\text{C}$

features $\pm 0.03\%$ total maximum error guaranteed from -25°C to 85°C , and load regulation over the 0 to 20 mA range of $\pm 0.004\%$. Military versions — AD2700/U and AD2700U/883 — feature screening to MIL-STD-883A, 5004.2, Class B, ans $+0.03\%$, -0.05% total maximum error over the full -55°C to 125°C temperature range. The new Analog Devices AD2701 and AD2702 offer identical specifications to the AD2700 but having -10 V and ± 10 V outputs, respectively. Available in 14-pin DIP packages, AD2700/L, AD2701 and AD2702, each feature an accuracy to within ± 0.001 V and minimize voltage noise (0.1 to 10 Hz) to below $50 \mu\text{Vp-p}$. Maximum output current is 20 mA and short circuit protection is provided.

*Analog Devices Ltd.,
Central Avenue,
East Molesey,
Surrey. 01-941 0466*

High Sensitivity Microphones

Two new 1/2" Measuring Condenser Microphones with improved sensitivity have been developed by Brüel & Kjaer. These microphones have the same sensitivity as 1" condenser microphones. Both are intended for general and low level sound measurements and are delivered with individual calibration chart. The 4165 is a free-field microphone with a linear 0° incidence frequency response from 4 Hz to 18 kHz ± 1 dB and a sensitivity of 50 mV/Pa. It fulfils the requirements to microphones in IEC R 123, IEC R 179 and ANSI S 1.4-1971, Types 2 and 3. The 4166 has a linear random incidence frequency response from 4 Hz to 8 kHz ± 1 dB and a

sensitivity of 50 mV/Pa. It fulfils the requirements to microphones in ANSI S 1.4-1971, Types 1, 2 and 3.

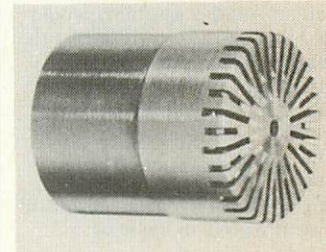

*Brüel & Kjaer
23 Linde allé
DK-2850 Naerum Denmark*

Burglar Alarm

ANTEX has launched what is believed to be the first D.I.Y. burglar alarm kit which complies with the strict standards of B.S.4737. The illustration shows the control box of the battery-operated version (Model A 1 B). The mains-operated Model A 1 MB is suitable for the average 3-bedroomed house. The electronic circuitry which provides the owner with a variety of useful facilities is housed in a strong, tamper-proof steel box. Special precautions were taken to prevent false alarms, the bane of so many alarm systems.

*ANTEX Ltd.,
Mayflower House,
Plymouth, Devon.*

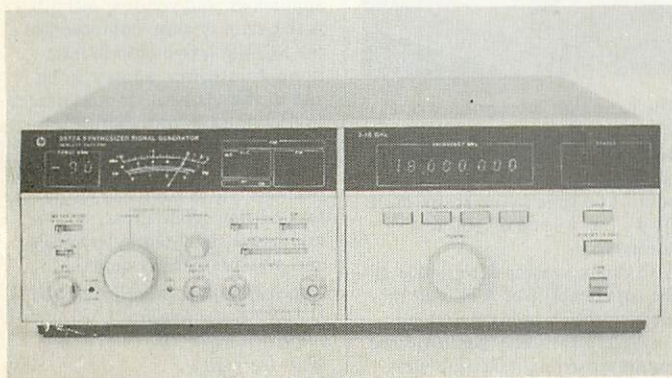

MARKET

Digital Cavity Wavemeter

Baytron Company, Inc. manufacturers and developers of millimeter wave components and systems, is proud to introduce the most distinctive contribution to waveguide passive device technology in a decade—direct reading digital cavity wavemeter.



Some of the features of this device are as follows: Digital readout — 8 mm LED characters; high resolution — 1 MHz; accuracy — 0.06% absolute error; excellent repeatability — zero backlash; and no spurious resonances — TM_{110} and TM_{010} modes eliminated. The Wavemeter will carry the part number 10E-49 followed by BAYTRONS 'band' designation, eg. Ka thru D. The digital processor and readout is always

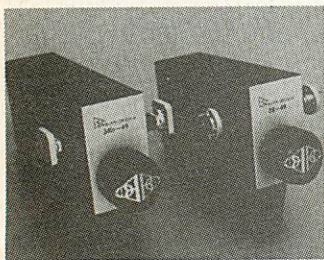

included in the package consisting of the two devices. These devices range in price from under \$ 4,000 to over \$ 10,000. It is suggested to order as soon as possible since demand has accounted for much of the first years production. Delivery is 20 weeks from date of order.

Reine Electronics B.V.,
Postbus 6730,
Den Haag 2040,
The Netherlands.

direct reading up to 40 kV

The latest high-voltage meter from Brandenburg Limited, the Model 109M, offers direct reading of c.h.t. voltages up to 40 kV. The instrument's very high impedance of 60 GΩ means that the current drain on the circuit under test is very small. This gives the meter a significant advantage over conventional multimeters which can draw as much as 50 μA, thereby reducing the voltage under test. The instrument's rugged construction makes it ideal for routine measurements taken, for example, during cathode-ray-tube servicing.

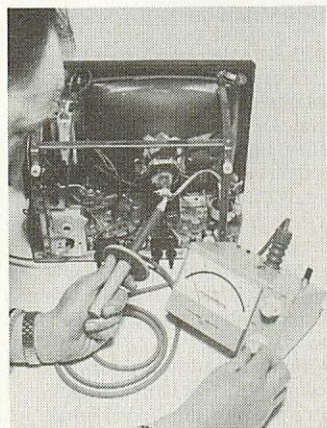

The instrument uses the latest semiconductor operational amplifiers to give a readout with a linear mirror scale, with divisions of 1 kV. The instrument is battery operated, and incorporates a battery test facility; battery life is 600 h. The high-voltage probe, with a special attachment for c.r.t. measurements, is available as an accessory. The model 109M costs £ 100 (plus V.A.T.) and the probe £ 5 (plus V.A.T.).

Brandenburg Limited,
High-Voltage Engineering
Division,
939, London Road,
Thornton Heath,
Surrey. CR4 6JE.

Model number cavity & processor	Operating frequency-GHz	Suggested list price F.O.B. fact
10E-49 Ka	26.5- 40.0	\$ 3,650.00
10E-49 B	33.0- 50.0	\$ 3,950.00
10E-49 Q	40.0- 60.0	\$ 4,225.00
10E-49 V	50.0- 75.0	\$ 4,500.00
10E-49 E	60.0- 90.0	\$ 5,050.00
10E-49 R	75.0-110.0	\$ 5,625.00
10E-49 N	90.0-140.0	\$ 6,475.00
10E-49 T	110.0-170.0	\$ 7,325.00
10E-49 G	140.0-220.0	\$ 8,450.00
10E-49 Y	170.0-260.0	\$ 9,850.00
10E-49 D	220.0-325.0	\$ 11,250.00

ELEKTOR PUBLISHERS LIMITED

Will be exhibiting a variety of working projects selected from current and future issues of ELEKTOR Magazine at

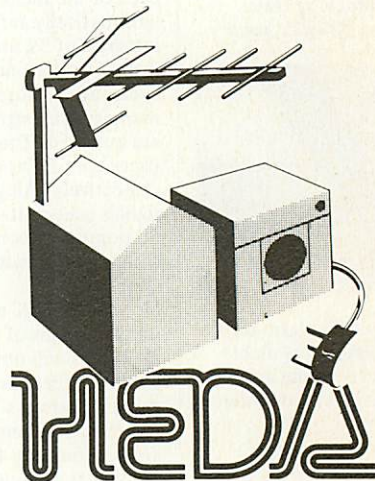

The International Home
Electronics & Domestic
Appliances Exhibition 23-27 MAY

plus
The Public Show

Sound & Vision '76 28-31 MAY
national exhibition centre, Birmingham

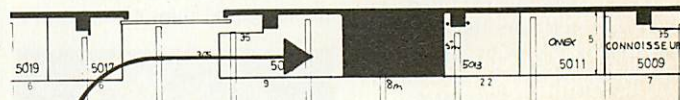

hall no 3
Stand no 5015

Back numbers of Elektor magazine and our own printed circuit boards will be available. Our editorial and advertising staff look forward to meeting you there.

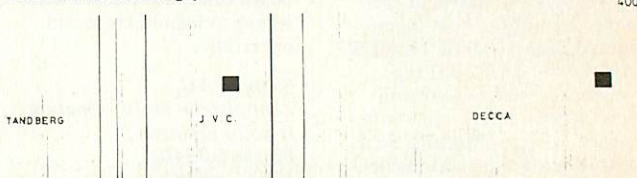

ELEKTOR PUBLISHERS LTD.
6 Stour Street, Canterbury, CT1 2XZ.
Tel: 0227 - 54430 — Telex: 965504

CHINAGLIA DINO - ELECTRICAL AND ELECTRONIC TEST EQUIPMENT MANUFACTURERS

CHINAGLIA PRESENT THE

DOLOMITI

20 kΩ/V a.c. and d.c.

A NEW HIGH SENSITIVITY MULTIMETER WITH ALL THE FEATURES YOU WILL EVER NEED

Accuracy: D.C. ranges, ±2.0%, A.C. & Ω ranges ±2.5%.
39 ranges: D.c. V, 0-150 mV, 500 mV, 1.5 V, 5 V, 15 V, 50 V, 150 V, 500 V, 1.5 kV; d.c.I, 0-50 μA, 500 μA, 5 mA, 50 mA, 0.5 A, 5 A; a.c. V, 5 V, 15 V, 50 V, 150 V, 500 V, 1.5 kV; a.c.I, 5 mA, 50 mA, 0.5 A, 5 A; dB -10 to +65 in 6 ranges; Ω 0-0.5 kΩ, 5 kΩ, 50 kΩ, 500 kΩ, 5 MΩ, 50 MΩ; pF 50 kpF, 500 kpF.

Automatic overload protection and high current range fusing. Scale mirror and fine pointer for accuracy of reading. Single knob main range switching and all panel controls. C.E.I. Class 1 movement with sprung jewel bearings. Extended 92 mm scale length for extra clarity. Compact ABS case 125 x 131 x 37 mm. Weight 650 g with batteries. Supplied complete with carrying case, fused leads, handbook and full 12-month guarantee. Optional 30 kV d.c. probe available.

Meter £ 33.15 incl. VAT (80p P. & P.)
 30 kV Probe £ 10.80 incl. VAT

ALCON Instruments Ltd.

19 MULBERRY WALK • LONDON SW3 6DZ TEL.: 01-352 1997

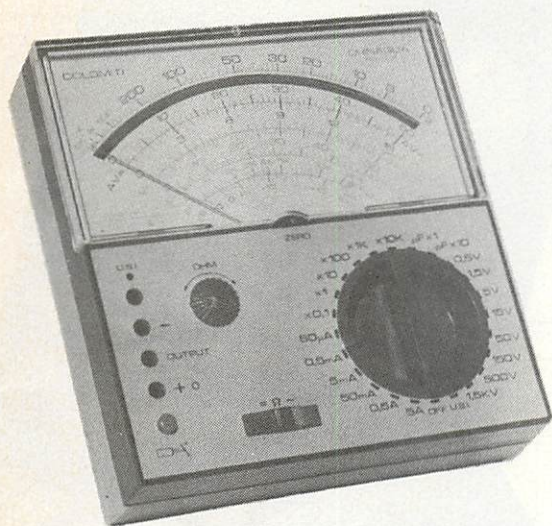

For details of this and the many other exciting instruments in the Chinaglia range, including multimeters, component measuring, automotive and electronic instruments please write or telephone.

babani press

new to elektor from babani

You can now obtain these best selling paper back reference works through Elektor at Canterbury

- FIRST BOOK OF TRANSISTOR EQUIVALENTS & SUBSTITUTES**
A handbook containing 73 pages of transistor equivalents and substitutes including British, German, Dutch, USA, Japanese and European manufacture 40 p
- SECOND BOOK OF TRANSISTOR EQUIVALENTS & SUBSTITUTES**
Complementary to the first book with over 56,000 additional equivalents and substitutes covering virtually all known types at time of publishing 95 p
- HANDBOOK OF INTEGRATED CIRCUITS (IC's) EQUIVALENTS & SUBSTITUTES**
115 pages of most available types of integrated circuits which have equivalents or substitutes 75 p
- PRACTICAL ELECTRONIC SCIENCE PROJECTS**
12 construction projects including Electroscopes, Gieger radiation counter, Digital clock etc. with circuit diagram & parts lists 75 p
- PRACTICAL STEREO AND QUADRAPHONY HANDBOOK**
Stereo recording, 10 plus 10 stereo amplifier, Quadrasonic reproduction etc. are detailed in its 90 pages 75 p

If you do not wish to spoil your copy of Elektor please make a note of the books you require with your name and address and send it to us with your remittance.

further paperbacks now available

- PRACTICAL ELECTRONIC PROJECTS**
A selection of construction projects with circuit diagrams and parts lists including a simple to build, portable radio receiver, 21 watt amplifier for guitars and a simple tester for Digital ICs ... 75 p
- 79 ELECTRONIC NOVELTY CIRCUITS**
Circuits include Burglar alarms, Reaction tester game, Wide range frequency doubler, Simple capacitance and Transistor tester, Intercom and signalling device etc. etc. Interchangeabilities and equivalents of solid state devices used are also given 75 p
- WORLDS SHORT MEDIUM & LONG WAVE FM & TV BROADCASTING STATIONS LISTING**
91 pages of lists giving station, country, KC/S and KW ratings 60 p
- THE COMPLETE CAR RADIO MANUAL**
Includes the selections of a radio and its installation, aerials, suppression and fault finding 90 pages 75 p
- MODERN TAPE RECORDING HANDBOOK**
Covers microphones, sound effects, tunes and editing, fault finding etc. contained in its 91 pages 75 p
- DIODE CHARACTERISTICS EQUIVALENTS & SUBSTITUTES**
European, USA, Asian, Japanese, USSR and Military service types etc. including rectifiers and zener diodes. 25000 entries with index in 9 languages, over 150 pages 95 p
- RADIO TV AND ELECTRONICS DATA BOOK**
Over 90 pages of facts and figures including wavelengths and frequency tables, International morse code, the Q code, Resistance wire data and many others 60 p
- RADIO TV INDUSTRIAL & TRANSMITTING TUBE & VALVE EQUIVALENTS**
Handbook of equivalents, British, European and USA designations of valves, CRT's and tubes, New system pro-electron CRT's tubes etc. etc. 60 p

Please send me (tick box)
 I enclose remittance of for the books and 20 p post and packing.
 Name
 Address

 Postcode



up-to-date electronics for lab and leisure
ELEKTOR

equa amplifier
 quadro systems
 tap sensor
 steam whistle
 distortion meter
 mos clock
 December 1974 35p

up-to-date electronics for lab and leisure
ELEKTOR



up-to-date electronics for lab and leisure
ELEKTOR

minidrum
 displays
 DIL-LED-probe
 big ben
 tv sound
 modulation systems
 how to gyrate
 February 1975 35p

up-to-date electronics for lab and leisure
ELEKTOR

Summer
 Circuits
 75

up-to-date electronics for lab and leisure
ELEKTOR

depending on relay

September 1975 35p



*see te

1374-4

ELEKTOR BACK ISSUES ARE STILL AVAILABLE

This is a selection from the contents of the various issues:

number 1:

- tup-tun-dug-dus
- equa amplifier
- mos clock
- distortion meter
- tap sensor
- electronic loudspeaker
- steam whistle

number 2:

- minidrum
- universal display
- dil led probe
- tv sound
- big ben
- modulation systems
- how to gyrate

number 3:

- tap preamp
- pll systems
- fido
- time machine
- compressor
- disc preamp
- a/d converter
- led displays

number 4:

- tup-tun tester
- interference suppression in cars
- thief suppression in cars
- supplies for cars
- cybernetic beetle
- the moth
- quadro in practice

number 5:

'Summer Circuits' issue, with over 100 circuits: amplifiers, generators, dividers, universal frequency reference, improved 7-segment display, receivers, power supplies, rhythm generators, measuring equipment, etc.

number 6

- edwin amplifier
- versatile digital clock
- phasing
- disco lights
- ota
- dual slope dvm
- car clock

numbers 7 and 8

sold out

number 9

- feedback pll for fm
- function generator
- racing car control
- simple mw receiver
- digital master oscillator
- pll-ic stereo decoder

number 10

- call sign generator
- morse decoder
- speech processor
- morse typewriter
- digital wrist watch

number 11

- tv tennis extensions
- ssb receiver
- tv sound front-end adapter
- dynamic noise limiter
- integrated voltage regulators

number 12

- preco
- ic rhythm generator
- polaroid timer
- led meters
- stylus balance

number 13

- integrated indoor fm aerial
- equin (2)
- digisplay
- versatile logic probe

Prices for single copies:

	U.K. and overseas surface mail	overseas air mail
1 to 4 and 6 to 8	50 p	85 p
number 5	85 p	110 p
from number 9	55 p	90 p

(prices include p & p)



FND 500 JUMBO 0.5" CC LED now only £ 1.02

SINTEL for CMOS

CMOS from the leading manufacturers, RCA & Motorola

CD4000 0.17	CD4027 0.46	CD4052 0.77	CD4085 0.59	MCM14552 8.05
CD4001 0.17	CD4028 0.74	CD4053 0.77	CD4086 0.59	Clock Chips
CD4002 0.17	CD4029 0.94	CD4054 0.95	CD4089 1.27	MK50253 ... 5.60
CD4006 0.97	CD4030 0.46	CD4055 1.08	CD4093 0.66	MMS314 ... 4.44
CD4007 0.17	CD4031 1.82	CD4056 1.08	CD4094 1.53	AY51224 ... 3.66
CD4008 0.79	CD4032 0.88	CD4057 20.35	CD4095 0.86	AY51202 ... 4.76
CD4009 0.46	CD4033 1.14	CD4059 3.64	CD4096 0.86	MK50250 ... 5.00
CD4010 0.46	CD4034 1.56	CD4060 0.92	CD4097 2.95	Displays
CD4011 0.17	CD4035 0.97	CD4061 16.43	CD4099 1.50	5LT-01 ... 5.80
CD4012 0.17	CD4036 1.82	CD4062 7.33	CD4502 0.98	DL704E ... 6.75
CD4013 0.46	CD4037 1.78	CD4063 0.90	CD4510 1.12	FND500 ... 1.02
CD4014 0.83	CD4038 0.88	CD4066 0.58	CD4511 1.28	Flat Cable
CD4015 0.83	CD4039 2.86	CD4067 2.95	CD4514 2.56	20WAY 1M 1.00
CD4016 0.46	CD4040 0.88	CD4068 0.18	CD4515 2.56	10M for ... 8.50
CD4017 0.83	CD4041 0.69	CD4069 0.18	CD4516 1.12	10WAY 1M 0.60
CD4018 0.83	CD4042 0.69	CD4070 0.18	CD4518 1.03	10M for ... 2.80
CD4019 0.83	CD4043 0.83	CD4071 0.18	CD4520 1.30	Verocases
CD4020 0.92	CD4044 0.77	CD4072 0.18	CD4527 1.03	751410J ... 2.64
CD4021 0.83	CD4045 1.15	CD4073 0.18	CD4532 1.16	751411D ... 2.94
CD4022 0.79	CD4047 0.74	CD4075 1.27	CD4556 0.74	751412K ... 4.00
CD4023 0.17	CD4048 0.46	CD4077 0.18	MC14528 ... 0.86	
CD4024 0.64	CD4049 0.46	CD4078 0.18	MC1453 ... 6.04	
CD4025 0.17	CD4050 0.46	CD4081 0.18	MC14553 ... 4.07	
CD4026 1.42	CD4051 0.77	CD4082 0.18	MC14566 ... 1.21	

RCA 1975 CMOS Databook 400 pages of data sheets and 200 pages of circuits, applications and other useful information £ 2.67 (No VAT)
 New MOTOROLA CMOS Databook £ 2.77 (No VAT)

ADVANCED CLOCK KIT

Complete kit including attractive slim case for 6 digit alarm clock with bleep alarm, snooze, high brightness driving of Jumbo LED displays, automatic intensity control - with optional add-ons of touch switch snooze control and crystal control/battery back-up £ 26.80

P.E. CAR CLOCK with Journey Timer

6 digit clock for use in any car with 12 V battery, with an independent journey timer incorporated. Bright Jumbo LED display comes on with ignition - automatic intensity control. Complete kit of all parts needed including case, PCB's and all components. Full instructions £ 39.50

Easy to Build E.E. DIGITAL CLOCK (Jan. issue). Kit of all components, including case etc., for this attractive clock with 12 mm green display. Full instructions £ 15.70
 32,768 KHz Min. Xtal: High accuracy/stability for clock or watch £ 3.60
 50 cps Crystal Timebase Kit - will provide stable 50 cps for any clock IC giving time accurate to within a few seconds a month; contains small PCB, 32,768 KHz Xtal, 3 CMOS IC's, trimmer, zener, C's, R's, IC skts £ 6.28
 MK60300 CMOS watch IC for LED display with date and seconds £ 12.50
 Display PCB's are available for clocks & counters (up to 8 digits)

SOLDERCON IC PIN SOCKETS

The sensible method for lowest cost sockets for IC's, displays, CMOS, TTL
 Strip of 100 for 50p 400 for £ 2.00 1000 for £ 4.00 3000 for £ 10.50
 8-way Boss Switch: 8 ultra-min. toggle switches in 16 pin DIL £ 2.60

ADD VAT at 8% (higher rate does not apply to any of the above)
 15p p&p on orders under £ 3. Free p&p on books and orders over £ 3.
 Price List & Data sent free with any order, or on request (an sae helps)
 Official Orders welcomed, written, phoned or telexed, from Univs, Polys, Schools, Govt. Dep'ts, Nat. Ind's., Rated Cos., etc. Fastest delivery for R & D
 Export orders: no VAT, add 35% (Europe) £ 1 (overseas) for Airmail p&p.
 (No Export outside Europe for databooks and transformers).



SINTEL 53(K) Aston St.
 Oxford Tel. 0865 49791

SPRING MADNESS BARGAIN SALE!

F.M. Tuners, 8-transistor chassis with Stereo-decoder and L.E.D. indicator	£ 10.90
Aircraft-band receiver. Just place near any radio	£ 3.90
Echo-chamber. (Endless tape). Variable delay	£ 34.50
Field-strength indicators. 1-250 MHz	£ 3.30
Stereo Amplifiers complete, 3-watt, 8-ohm	£ 2.75
10-watt Amplifiers, 12 volt D.C. 3/8/15-ohm	£ 3.90
Cartridges, Acos GP 104, Ceramic/Diamond	£ 1.50
Cartridges, Acos GP 101, Crystal/Sapphire/Compatible	£ 0.50
Speakers, 2 1/2"-8-ohm	£ 0.35
Speakers, Car Stereo, 8-ohm, 5-watt. In cabinets	£ 2.50
Dynamic Tape Mikes with remote-control facility	£ 0.90
Crystal Tape Recorder Mikes	£ 0.60
Crystal Mike Inserts with bracket	£ 0.20
Indicators, 12-volt L.E.D. In Chrome Bezel	£ 0.35
Bargain Bags 4lbs Caps/Resistors/Transistors/Diodes	£ 4.00
Controls, Volume/Pre-set (Rotary & Slider) Assorted 100	£ 2.50
Transistors, 20 NPN/PNP, All new and marked	£ 1.00
Transistors, 100 NPN untested	£ 1.00
Diodes, 100 Germanium untested	£ 0.50
Diodes, 100 Silicon untested	£ 0.50
Diodes, 100 Zener untested	£ 0.50
Pack 1 100 resistors, 100 ceramics, 100 diodes	£ 1.00
Pack 2 100 resistors, 100 ceramics, 100 polystyrene	£ 1.00
Pack 3 100 resistors, 100 S/Mica/Ceramic, 100 Polyester	£ 1.00

ALL ABOVE ITEMS PLUS 12 1/2% VAT

Fluorescent 12-volt Camping Lights, 21" 13-watt	£ 4.90
12" 8-watt	£ 3.90
Disco type 3-Channel flashing light units, Built-in mike. No connection needed to amp	£ 17.50
Multimeters, AC 0-1000V, DC 0-1000V, 0-100 mA, 0-150 kohm	£ 3.50
Multimeters, AC 0-500V, (10 ranges) DC 0-500V, (12 ranges) DC Current 0-25 uA to 0-10 amps (10 ranges) Resistance 0-100 ohms to 0-16 Mohms, (4 ranges)	£ 11.30
Panel Meters, 0-50 uA, 2 3/4" x 1 1/4"	£ 2.50
Soldering Irons, 15-watt, Pencil Bit	£ 1.20
Servisol Switch Cleaner (with Snorkel)	£ 0.50
Copper-clad Fibre Glass Board, Single-sided, Square foot	£ 1.00
Double-sided	£ 1.25
Fotolok Light sensitive spray for printed circuit making	£ 1.30
Developer for same	£ 0.30
Ferric Chloride for etching	£ 0.40

ALL ABOVE ITEMS PLUS 8% VAT

G.F. MILWARD, 369 Alum Rock Road,
 Tel. 021-327 2339, Birmingham B8 3DR.

POSTAGE: Below £ 10 50p
 Above £ 10 Free

HB ELECTRONICS

54 Montagu Street Kettering Northants Phone Kettering 83922
 shop open Monday to Saturday 9.00 to 6.00 early closing Thursday 1.00 p.m.

SEMICONDUCTORS

AA 119	10	BC 517	POA	OA 200	10
AC 126	16	BC 547	12*	OA 202	10
AC 127	16	BC 548	12*	OC 28	75
AC 128	16	BC 549	12*	OC 35	50
AC 176	19	BC 557	15*	OC 42	40
AC 187	19	BC 558	15*	OC 44	18
AC 188	19	BC 559	15*	OC 45	16
AD 149	50	BCY 70	15	OC 70	15
AD 161	50	BCY 71	15	OC 71	15
AD 162	50	BCY 72	15	OC 171	30
AF 114	25	BD 131	40	OC 171	75
AF 115	25	BD 132	40	OR 12	70
AF 116	25	BD 139	65	TIL 209	20
AF 117	25	BD 140	75	TIP 31A	50
AF 118	45	BD 242	POA	TIP 32A	55
BA 145	16	BF 194	10*	TIP 41A	70
BA 148	16	BF 195	10*	TIP 42A	85
BA 154	16	BF 196	10*	TIS 43	30
BA 191	POA	BF 197	10*	ZTX 107	10
BB 103	30	BF 198	12*	ZTX 108	10
BB 104	70	BF 199	12*	ZTX 109	10
BB 105	35	BF 200	30	ZTX 300	20
BB 109	POA	BF 254	30	ZTX 500	20
BB 110	30	BF 255	30*	1N 914	5
BC 107	10	BF 494	POA	1N 4148	4
BC 108	10	BF 495	POA	1N 4001	4
BC 109	10	BFX 29	28	1N 4002	4
BC 139	25	BFX 30	28	1N 4003	4
BC 140	30	BFX 34	POA	1N 4004	5
BC 141	26	BFX 41	POA	1N 4005	5
BC 142	20	BFX 84	25	1N 4006	6
BC 143	24	BFX 85	25	1N 4007	6
BC 147	10*	BFX 86	25	2N 1613	20
BC 148	10*	BFX 87	35	2N 2646	45
BC 149	10*	BFX 88	25	2N 2926B	10*
BC 157	10*	BFX 89	60	R	10*
BC 158	10*	BFY 50	15	2N 2962	10*
BC 159	10*	BFY 51	15	2N 2962Y	10*
BC 160	35	BFY 52	15	2N 2926G	10*
BC 161	35	BR 100	30	2N 3053	16
BC 177	18	BR 101	30	2N 3054	45
BC 178	18	BRY 39	40	2N 3055	50
BC 179	18	BRY 56	50*	2N 3819	20
BC 182L	12*	BU 105/02 200*	40603	75	
BC 183L	12*	BU 108	250*	40673	75
BC 184L	12*	BY 100	25		
BC 212L	12*	BY 127	15		
BC 213L	12*	E 100	40		
BC 214L	12*	E 300	55		
BC 237	16*	MJE 340	50*		
BC 238	16*	MJE 341	80*		
BC 239	20*	MJE 345	120		
BC 261	20	MJE 3055	75		
BC 262	25	MPF 102	30		
BC 337	15*	OA 81	12		
BC 338	15*	OA 90	9		
BC 516	POA	OA 91	9		

DISCOTHEQUE EQUIPMENT

ULTRAVIOLET BULB: 75 w 'Balck Magic'. No control gear required, ES or BC fitting 240 v AC. £ 7.50

SOUND TO LIGHT
 Pulsar Zero 2250: £ 27.50
 3 channels of 750 w each. Connects to any amplifier and automatically compensates for any change in output level. No need to adjust anything to keep lights operating with different records or volume settings.

Pulsar Zero 3000: £ 69.50
 3 channels of 1 kw each. Connects to any amplifier and offers full control facilities: normal sound to light, variable speed sequence, manual, low/full brightness switch and special music sequence position-sequence speed on each channel is independently varied by the music input giving unique and constantly varying output which still relates to the sound input.

STROBE
 Pulsar Super Strobe £ 27.50
 Frequency variable, 4 to 20 Hz, 4 joule output, suitable for small and medium halls. Attractive case, free standing or wall mounting.

FITTINGS
 100 w BC or ES spot bulbs, red, yellow, green, blue, clear. £ 1.20
 Swivel spot bulb holders, Wall, ceiling or spot bank mounting, BC or ES £ 1.70
 Spot bank with three holders and cable, BC or ES. £ 17.50

74 Series TTL

7400 12	7404 12	7410 13	7442 55	7476 26	7491 55	74121 28	74174 83
7401 12	7405 15	7413 31	7445 71	7483 75	7492 45	74122 28	741771.00
7402 12	7406 30	7432 25	7447 79	7486 26	7493 40	74141 63	741961.34
7403 12	7408 15	7441 62	7474 26	7490 40	74100 89	74145 58	

OTHER COMPONENTS

Zener diode 1 w 3.3 v to 200 v E24 Series 30 p*
 Zener diode 400 mw 3.3 v to 47 v E12 Series 12 p*
 Resistors, Carbon Film 1/2 w 5% E12 Series 2 p*
 Capacitors C280 250 v dc, 0.1 uF to 2.2 uF E6 Series 6 p*
 Veroboard 0.1" and 0.15" 2 1/2" x 5" 40 p*
 Sub. miniatures presets. Fit 0.1" board 8 p*
 Resistors, wire wound, 2.5 w, 0.22 to 10 Ohms E24 20 p*
 Resistors, metal film, (MR 25 type) 1% 4R99 to 100 k E 96 25 p*
 Potentiometers: Single gang have nylon shaft

	5 k	10 k	25 k	50 k	100 k	250 k	500 k	1 m	2 m		
Single gang	log and lin								log	30 p*	
Single gang & DPST	log	log and lin				log	log & lin	log		50 p*	
Tandem	log and lin								log	80 p*	
Tandem & DPST	N/A								log	N/A	95 p*
	10	11	12	13	15	16	18	20	E 24 = whole series and multiples		
	22	24	27	30	33	36	39	43	E 12 = bold figures		
	47	51	56	62	68	75	82	91	E 6 = boxed figures		

BULK OFFERS

1N 4001/2	30 p/10
1N 4003/4/5	45 p/10
1N 4006/7	50 p/10
1N 4148	20 p/10
BC 107/8/9	75 p/10
7418 diil	£ 1.95/10
NE 555	£ 1.60/4
Red LED	£ 1.00/10
Yellow/Amber/Green LED	£ 1.50/10
BFY 50/1/2	£ 1.50/10
BC 212L	80 p/10*

SPECIALS

Few only left in stock: 8 track 12 V + or - earth car cartridge player. Used and untested, but complete £ 5.00*

LW MW & FM portable cassette radio, battery/mains, internal and remote microphones, carrying handle, used, untested, but complete £ 10.00

ORDERING INFORMATION

VAT add high rate to * items, standard rate to all others.

POST free on orders over £ 5.00, otherwise please add 30 p. Overseas please add freight costs and state method of despatch required (BFPO excepted).

DELIVERY by return 1st class post unless otherwise requested. Express delivery available by City Link or securitor if required. Phone for details.

PAYMENT Cash, Cheque or Postal order with order Access or Barclay card by phone or letter for orders over £ 2.00.

GUARANTEE All devices are brand new and full spec unless otherwise stated. Any faulty item returned unused and in good condition within seven days will be exchanged or refunded.

Build it yourself!

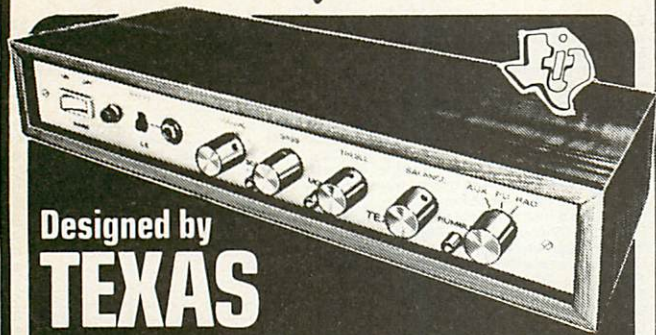

Designed by
TEXAS

Featured by **PRACTICAL WIRELESS**
SOLE U.K. DISTRIBUTORS - HENRY'S

Build the Texan stereo amplifier, then you can be doubly proud! For a start, you'll own a superb home entertainment unit. And have had all the pleasure of doing it yourself, with the Henry's kit.

Look at the Texan specification

Incorporating fully integrated stereo preamp and power amp, with 6 IC's, 10 transistors, 6 rectifiers and zener diodes. Plus stabilised, protected circuitry, glass fib pcb; Gardners low-field low-line mains transformer; all facilities and controls. Slim design, chassis 14 1/2" x 6" x 2" overall, 20 watts per channel RMS, less than 0.1% distortion at 1 kHz.

- ★ Can be built Stage by stage Ask for leaflet 20.
- ★ Everything necessary supplied. Full after sales service and guarantees.

KIT PRICE
£35.00
Inc. VAT + £1 p&p

Built and tested
£45.00 inc. VAT
+ £1.00 p&p.

THE NATURAL FOLLOW-ON - THE TEXAN FM TUNER KIT!

KIT PRICE
£25.95
Inc. VAT +
50p p&p.

Build the matching Texan stereo tuner! Features advanced varicap tuning. Phase lock loop decoder. Professionally designed circuit. Everything you need is in the kit. From the glass fibre pcb to the cabinet itself. Excellent spec: 2.5 uV aerial sensitivity. 500 mV output (adjustable). Tuning range 87-102 MHz. Mains powered.

Built and tested £30.95 inc. VAT + 50p p&p.

VIDEO SPORT

... all the electronic excitement you could wish for!

★ OVER 10,000 ALREADY SOLD ★ IDEAL GIFT

An up-to-the-minute game. Plugs into your own TV aerial socket. Switch on. And you're away! Choose your game - football, tennis or hole-in-the-wall. Absolutely safe. For you. Your children. And your TV. Mains powered. List Price £42.50

HENRY'S PRICE - ONLY £29.50 inc. VAT + 50p p&p.



WHATEVER YOU DO, DON'T FORGET YOUR LATEST HENRY'S CATALOGUE!



For this new edition, we have made hundreds of changes and additions. It has over 200 pages, containing virtually everything for amateurs and professionals. And you'll have no bother at all finding everything you want, because there's a complete alphabetical index as well as a section index. Together, they put you right on course for the items you need. From Sinclair projects to educational kits. Oscilloscopes to panel meters. Coils to capacitors. Transistors to valves. Loudspeakers to microphones - all at competitive prices. Over 200 pages of vital statistics - just for you! So send now for your copy.

ONLY 50p

- 25p cart./pack.

FREE to Educational Establishments when ordered on official headed notepaper.

- Over 5000 items inside!
- Every copy contains a free 50p voucher.
- Many new items.
- Over 200 pages.

HENRY'S

SELF-SERVICE CENTRES 404 and 309 EDGWARE ROAD, LONDON W2
Bargains galore - Call in and see for yourself!

404/6 EDGWARE ROAD, LONDON W2 01-402 8381

LOWER SALES FLOOR, 231. TOTTENHAM CT. RD., LONDON W1 01-636 6681

NEW MIDLANDS STORE 94/96 UPPER PARLIAMENT STREET, NOTTINGHAM. 0602-40403
All mail to Henry's Radio, 303 Edgware Road, London W2

Technology spoken here:

New this month are 520 MHz divide-by-ten ICs, the 11C90 at £14.00; a new extruded aluminium heatsink for the TDA2020 for 70p, when purchased with the IC, and a new series of cases, especially conceived for our range of tuner modules, for AM, FM, and now TV sound "off-air".

5600	Varicap Mosfet with 4 tuned RF ccts	10.00	Radio/MPX and linear ICs
EC3202	Varicap FET/Bipolar min. tunerhead	5.00	CA3089E 1.94
7252	Top quality tuner VHF to audio		CA3090AQ 3.75
	Varicap tuned with 3 meter outputs	24.00	MC1310P 2.20
7253	Tuner with built-in stereo decoder.		MC1350P 0.70
	Varicap tuned.	24.00	SN7660N 0.75
	Edgewise illuminated meters: 35uA, 35 x 14mm as used with Larsholt 7252/7253		TBA051 1.81
			uA720PC 1.40
9001	Frequency scale 88-108	2.50	TBA810AS 1.09
9002	Signal strength scale 0-10	2.50	TCA940E 1.80
9007	Tuning meter scale 3 - 0 - 3	2.50	(Prices for heatsinks, when purchased with ICs: 14p each 810/940).
AB47	Multiturn varicap control pot. 40 turn 100k 0.35		TDA2020 2.99
TV SOUND SYSTEM			
7700	"Off-air" UHF TV sound receiver		NE560 2.50
	Varicap tuned, with interstation muting, and sound detection at 38MHz	26.00	NE561 2.50
7701	Chassis and cabinet for above (available March 1976)	7.50	NE562 2.50
5700	UHF TV varicap tunerhead	5.50	NE565 2.50
5770	Tunerhead + 4 way pre-selector	8.60	
8011	6 station electronic station selector, incorporating a muting output, AFC lock and scan tuning. Built.	14.99	Toko filters for AM/FM/TV/MPX
8005	A kit of accessories for the 7252/3 tuner, to provide power stabilizer MPX filter and audio gain, meter drives.	4.99	MFA41T 1.65
Special Offer Packs			
SO7448	6 x 7448 + 6 x DL704	10.00*	CF7470C 0.55
SO7001	CT 7001 + 6 x DL704 + Socket	12.50*	SFE6.0MA 0.80
SOFM	KB4400 + KB4402 + 586 + 7BA220K	3.00	CFS10.7 0.40
			BBR3132 2.25
			BLR2007 1.60
			BLR3107 1.60
			OTHER AM/FM COILS IN OUR LISTS

Logic

11C90	14.00
Varicap Diodes	
MVAM 1	2.75
MVAM 2	1.05
EA102	0.30
BA121	0.30
MV104	0.45

Send an SAE for a free price and stock list - which has been revised extensively during March. There is a new Larsholt Signalmaster FM tuner - and a companion 25+25W audio amplifier kit, as well as further details on our broad range of specialist wireless and audio products.
PP 22p per order, VAT is generally at 25% - and the min. CWO charge is £1. Min. invoice £7.50, Catalogue 40p .

(* 8% VAT)

ambit INTERNATIONAL

25 High Street, Brentwood, Essex, CM14 4RG. Tel: 216029; Tlx: 995194.

printed circuit boards, name plates, labels and panels.....

Specialising in medium and short runs, backed up with full Art and Tooling services from:

G.M. TECHNICAL SERVICES,

130 Lancaster Rd., New Barnett, Herts. Tel: 01 440 0919

publishers announcement

The government has announced that as from Monday 12th of April the higher rate of VAT is reduced from 25 per cent to 12 1/2 per cent. Some of the advertisements in this issue of Elektor may still show VAT at 25 per cent due to lack of time for amendment. We recommend that readers should check with the advertiser regarding the rates quoted before ordering. The publishers can not be held responsible for any error in VAT rates quoted.



As our Editorial Staff will be at the HEDA and Sound and Vision exhibitions in Birmingham from May 23rd to 31st, the Technical Queries 'phone-in' will not operate on Monday May 24th and 31st. We shall, however, be pleased to talk with you in person and answer your queries at our exhibition stand:

Hall No. 3,
Stand No. 5015,
National Exhibition Centre,
Birmingham.

order a subscription to elektor

Look through this issue of ELEKTOR and you will find that ELEKTOR is not just one more electronics magazine. ELEKTOR is different

. different

- in its presentation
- in its style and content
- in its use of new techniques and components in practical circuits.

ELEKTOR is the magazine for your profession, study or hobby. ELEKTOR avoids long-winded theoretical discussions and the like. Instead, it gives practical applications.

If you order a subscription, you will be sure to receive ELEKTOR regularly*.

Fill in the form overleaf and send it today to ELEKTOR PUBLISHERS LTD.

* ELEKTOR is also on sale at leading component shops, newsagents and stationers throughout the UK.

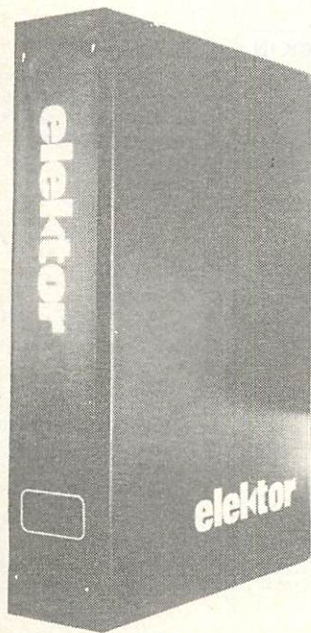

elektor binders

The dark green binder collects your loose copies of ELEKTOR into one handy volume.

Each copy is fastened simply and firmly with a metal pin, and any copy can easily be removed later without disturbing the others.

Matching self-adhesive labels are provided to show the year. ELEKTOR binders can be ordered from our Canterbury office using the form overleaf.

Price: £ 1.85 (incl. VAT and p&p).

i like elektor

- Subscription 1976 (11 issues*), no. 9 to 20,
 - UK and overseas surface mail: . . . £ 6.25
 - overseas airmail: £ 11.00
- Subscription 1976, UK and overseas surface mail,
 - from no. 10 (February 1976) £ 5.80
 - from no. 11 (March 1976) £ 5.25
 - from no. 12 (April 1976) £ 4.70
 - from no. 13 (May 1976) £ 4.15
 - from no. 14 (June 1976) £ 3.60
 - from no. 15/16 (July/August 1976) £ 3.05
 - from no. 17 (September 1976) . . . £ 2.15
 - from no. 18 (October 1976) £ 1.60
 - from no. 19 (November 1976) . . . £ 1.05
 - from no. 20 (December 1976) . . . £ 0.50
- Back issues 1975,
 - no. 1 to 4 and no. 6 to 8, each . . . £ 0.50
 - no. 5 (summer circuits) £ 0.85
- Single copies 1976,
 - no. 9 to 14 and no. 17 to 20, each . £ 0.55
 - no. 15/16* £ 0.95
- Elektor binders £ 1.85

*Please note that no. 15/16 (July/August) is a double issue: our 'Summer Circuits' issue, with more than 100 circuits.

All prices include postage and packing.

2. FOLD HERE

Postage will be paid by Elektor

Do not affix Postage Stamps if posted in Gt. Britain, Channel Islands or N. Ireland

BUSINESS REPLY SERVICE
Licence No. CU 203

ELEKTOR PUBLISHERS LTD.,
6, Stour Street,
CANTERBURY CT1 2BR



1. FOLD DOWN ALONG THE DOTTED LINE

3. FOLD HERE AND TUCK IN

I would like to receive a

- subscription to ELEKTOR for 1976 at £ 6.25
- subscription to ELEKTOR starting with no.
- subscription to ELEKTOR for 1976 (airmail) at £ 11,—
- back issue(s) of ELEKTOR 1975 at £ 0.50 per copy.
- dark green ELEKTOR binder at £ 1.85

I am not enclosing money, but await your invoice.
(please use capital letters and include your post code)

Name _____

Address _____

Post code _____

Cut out address and glue it on envelope; cut out order slip and enclose it in envelope.

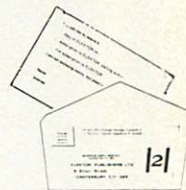

or:

Remove page then fold and tuck in as indicated.
No stamp is needed.

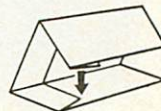

CHROMASONIC electronics

Dept. 9, 56, Fortis Green Road,
Muswell Hill, London, N10 3HN.
telephone: 01-883 3705

mix prices

C-MOS

	1-24	25-99	100up
CD4000AE	19p	17p	14p
CD4001AE	19p	17p	14p
CD4002AE	19p	17p	14p
CD4006AE	£1.59	£1.33	£1.06
CD4007AE	23p	19p	15p
CD4008AE	£1.75	£1.46	£1.17
CD4009AE	Use	CD4049*	
CD4010AE	Use	CD4050*	
CD4011AE	19p	17p	14p
CD4012AE	19p	17p	14p
CD4013AE	59p	50p	46p
CD4014AE	£1.75	£1.46	£1.17
CD4015AE	£1.75	£1.46	£1.17
CD4016AE	55p	48p	44p
CD4017AE	£1.29	£1.07	93p
CD4018AE	£1.89	£1.56	£1.25
CD4019AE	80p	66p	53p
CD4020AE	£1.97	£1.64	£1.31
CD4021AE	£1.75	£1.46	£1.17p
CD4023AE	19p	17p	14p
CD4022AE	£1.83	£1.53	£1.27
CD4024AE	£1.26	£1.05	84p
CD4025AE	19p	17p	14p
CD4026AE	£2.79	£2.32	£1.86
CD4027AE	98p	82p	65p
CD4028AE	£1.53	£1.28	£1.02
CD4029AE	£1.89	£1.56	£1.15
CD4030AE	71p	59p	47p
CD4035AE	£1.75	£1.46	£1.17
CD4040AE	£2.01	£1.69	£1.34
CD4042AE	£1.49	£1.24	99p
CD4046AE	£2.15	£1.79	£1.44
CD4050AE	69p	58p	46p
CD4051AE	£2.78	£2.32	£1.85
CD4052AE	£2.78	£2.32	£1.85
CD4056AE	£2.12	£1.76	£1.41
CD4060AE	£2.39	£1.99	£1.55
CD4066AE	£1.13	94p	75p
CD4068AE	28p	24p	19p
CD4069AE	28p	24p	19p
CD4070AE	28p	24p	19p
CD4071AE	28p	24p	19p
CD4077AE	71p	59p	47p
CD4081AE	28p	24p	19p
CD4082AE	28p	24p	19p
CD4085AE	£1.28	£1.06	85p
CD4086AE	£1.28	£1.06	85p
CD4093AE	£1.56	£1.20	£1.04
CD4099AE	£2.95	£2.46	£1.96
CD4511AE	£2.36	£1.79	£1.44
CD4528AE	£1.30	£1.08	87p

I.C. SOCKETS

Pin Sockets, pins in strips of 100. Just snip off what you need. 65p per strip.
Dual in line *
8 pin 13p. 24 pin 26p. 105
14 pin 15p. 28 pin 30p. 8 pin 31p.
16 pin 15p. 36 pin 39p. 10 pin 35p.

FREE CIRCUITS

Our 8 Page A4 Audio I.C. Booklet is supplied FREE with purchases of Linear I.C.'s worth £1. or more (35p. if sold alone). Contains circuits and pin connections
15 Amplifiers 250 mW to 20 watts
5 Audio Pre-Amplifiers
1 Tape Pre-Amplifier
1 Power Driver
1 Instrument Amplifier (Bifer)
1 General Purpose Mini Amplifier
1 D.C. Controlled Gain Control
1 Micro-mini Radio (2 I.C.'s)

PHOTO-DARLINGTON

V_{cc} 25v 2N5777
V_{be} 25v
V_{be} 8v
I_b 250 mA
P_d 200 mW
Hfe 2500

LINE-O-LIGHT



NEW LED Linear Cursors each device contains 10 light emitting diodes in a 20 pin dual in-line package. Ideal for solid state analogue meters or dials. Type 101 RED £2.26. * Complete with leaflet.

mix prices

74 TTL

	1-24	25-99	100*
7400	14p	12p	10p
7401	14p	12p	10p
7402	14p	12p	10p
7403	15p	13p	10p
7404	16p	13p	11p
7408	16p	13p	11p
7409	16p	13p	11p
7410	16p	13p	11p
7413	29p	24p	20p
7417	27p	22p	20p
7420	16p	13p	11p
7427	27p	22p	18p
7430	16p	13p	11p
7432	27p	22p	18p
7437	27p	22p	18p
7441	75p	62p	50p
7442	65p	55p	43p
7445	85p	71p	57p
7447	81p	75p	62p
7448	75p	62p	50p
7447A	95p	83p	67p
7470	30p	25p	20p
7472	25p	21p	17p
7473	30p	25p	20p
7474	32p	26p	21p
7475	47p	39p	31p
7476	32p	26p	21p
7482	75p	62p	50p
7485	£1.30	£1.09	87p
7486	32p	26p	21p
7489	£2.92	£2.80	£2.10
7490	49p	40p	32p
7491	65p	55p	45p
7492	57p	46p	36p
7493	45p	40p	32p
7495	67p	55p	45p
74100	£1.08	89p	72p
74107	35p	28p	22p
74121	34p	28p	23p
74122	47p	39p	31p
74141	78p	63p	53p
74145	68p	58p	48p
74154	£1.67	£1.48	86p
74174	£1.00	83p	67p
74180	£1.06	88p	71p
74181	£3.20	£2.50	£1.90
74192	£1.35	£1.14	90p
74193	£1.35	£1.14	90p
74196	£1.64	£1.34	99p

mix prices

3 1/2 DECADE DVM I.C.

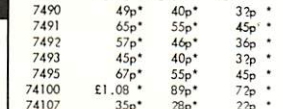

This state-of-the-art MOS LSI chip contains all the logic necessary for a 3 1/2 decade, dual slope integrating, automatic polarity detecting DVM. Supplied with free data and circuit booklet. AY-5-3507

OUR PRICE ONLY £6.59.*
(Data and Circuit Booklets alone 20p.)

The AY-5-1224 tick-tock

Another marvel from G.I. A 16 pin 12-24 hr. Clock I.C. with 25 pin capability and low external parts count. Supplied with manufacturers detailed leaflet £3.95p*(inc. VAT) (Leaflet alone 20p.). Full Kit (excluding case) available towards end of 1975. Phone Clive for details.

MULLARD MODULES

Still make the simplest, highly reliable F.M. tuner

LP1186	Varactor front end	£5.38
LP1185	I.F. Strip	£6.22
LP1400	Multiplex decoder	£5.62

LINEAR I.C.'s

555 (8 pin dip)	55p	AY-1-0212	£6.93	LM2111	£1.12	SN76001N (TAA611)	£1.82
555 (TO-99)	81p	AY-1-5051	£1.44	LM3900	69p	SN76003N	£3.30
556 (14 pin dip)	£1.29	AY-5-1224	£3.95	LM3909	66p	SN76013N	£1.98
703 (RF/IF Amp)	68p	AY-5-3500	£6.59	LP1186	£8.60	SN76023N	£1.98
709 (10-99)	45p	AY-5-3507	£6.59	LP1185	£6.95	SN76227N(MC1327)	£1.89
709 (14 pin dip)	39p	AY-5-4007	£7.94	LP1400	£9.02	SN76532N	£1.86
710 (10-99)	45p	BHA0002	£3.01	MC1303L	£1.94	SN76544N	£1.81
710 (14 pin dip)	44p	CA2111	£1.19	MC1306P	85p	SN76550-2(TAA550)	89p
711 (10-99)	51p	CA3045	£1.69	MC1310P	£2.10	SN76660N(TBA120)	75p
711 (14 pin dip)	44p	CA3046	88p	MC1312P	£2.52	SN76666N (CA3065)	£1.12
720 (A.M. Radio)	£1.76	CA3053	59p	MC1314P	£4.34	TAA263	£1.50
723 (10-99)	£1.09	CA3065	£1.60	MC1327P	£1.48	TAA300	£2.16
723 (14 pin dip)	55p	CA3075	£1.64	MC1330P	£1.60	TAA310A	£1.87
741 (8 pin dip)	30p	CA3078	£1.26	MC1339P	£1.60	TAA320	£1.44
741 (10-99)	43p	CA3080	59p	MC1350	68p	TAA350	£2.43
741 (14 pin dip)	36p	CA3081	£1.86	MC1351	92p	TAA370	£3.45
747 (14 pin dip)	£1.04	CA3082	£1.86	MC1352	92p	TAA550	75
748 (8 pin dip)	42p	CA3089E (TDA1200)	£2.43	MC1357	£1.60	TAA570	£2.75
748 (10-99)	46p	CA3097E	£1.67	MC1358	£1.23	TAA700	£5.03
748 (14 pin dip)	49p	CA3123E	£1.76	(CA3095)	£1.56	TBA1205	£1.25
753 (F.M. 1st I.F)	£1.08	CA3130	84p	MC1455(555T)	65p	TBA231	£1.02
75491	88p	CA3401E (LM3900)	68p	MC1456CPC1	£1.77	TBA281 (723)	£2.59
75492	£1.10	CA3600E	£1.44	MC1468G	£2.30	TBA500Q	£3.16
Regulators 100mA		L005T1 (TO-3)	£1.46	MC1495L	£4.48	TBA520Q	£3.85
78105WC (TO-92)	60p	L036T1 (TO-3)	£1.46	MC1496G	£1.01	TBA530Q	£3.27
7812WC (TO-92)	60p	L037T1 (TO-3)	£1.46	MC3302P	£1.65	TBA540Q	£3.72
7815WC (TO-92)	60p	L129 (SOT-32)	85p	MC3401P	81p	TBA550Q	£5.29
Regulators 100mA		L130 (SOT-32)	85p	MFC4000B	87p	TBA560CQ	£5.29
78105AWC (TBA625A)	90p	L131 (SOT-32)	85p	MFC4006A	85p	TBA625A	£1.03
7812AWC (TBA625B)	90p	LM301T (TO-99)	65p	MFC6030A	85p	TBA625B	£1.03
7815AWC (TBA625C)	90p	LM301A (TO-99)	67p	MFC6040	£1.01	TBA625C	£1.03
Regulators 500mA		LM301A (S/B pin dip)	59p	MM5314	£4.80	TBA651	£1.87
78M05HC	£1.35	LM307 T (TO-99)	59p	MM5316	£9.99	TBA720Q	£2.79
78M12HC	£1.35	LM307 S (8 pin dip)	57p	MVR5V (TO3)	£1.45	TBA750Q	£2.79
78M15HC	£1.35	LM308 T (TO-99)	£1.96	MVR15V(TO3)	£1.45	TBA800	£1.11
78M18HC	£1.35	LM308 S (8 pin dip)	98p	NE5401	£1.25	TBA8105	£1.24
78M24HC	£1.35	LM308A T (TO-99)	£7.92	NE546A	£1.16	TBA810AS	£1.24
Regulators 1A		LM308A S (8 pin dip)	£6.90	NE555V	59p	TBA820	86p
7805KC (TO-3)	£2.09	LM309K	£2.34	NE555	£1.29	TBA920Q	£4.71
7817KC (TO-3)	£2.09	LM339	£2.25	NE560B	£5.06	TBA990Q	£4.71
7815KC (TO-3)	£2.09	LM370N	£2.85	NE561B	£5.06	TC3470Q	£5.24
7818KC (TO-3)	£2.09	LM371	£2.08	NE562B	£5.06	TC3476	£2.16
7824KC (TO-3)	£2.09	LM372N	£1.99	NE563	£2.96	TC3800Q	£7.24
Regulators 1A		LM373N	£2.99	NE565N	£1.83	TC38305	£1.04
7805UC (TO-220)	£1.72	LM377N	£2.71	NE566V	£1.87	TC3940	£2.25
7812UC (TO-220)	£1.72	LM380	£1.25	NE567V	£2.63	TDA1054	£1.50
7815UC (TO-220)	£1.72	LM381	£1.85	SD6000	£1.22	TDA1205	£2.43
7818UC (TO-220)	£1.72	LM382	£1.66	SL414A	£2.09	TDA1405	80p
7824UC (TO-220)	£1.72	LM383	£1.66	SL415A	£2.75	TDA1412	80p
ICL8030	£3.52	LM703	68p	SL437D	£7.50	TDA1415	80p
		LM8120	£1.03	SL440	£2.85	TDA2010	£3.00
				SN75491N	88p	TDA2020	£3.75
				SN75492N	£1.10	ULN2111A	£1.52
						ZN414	£1.26

ZN414 Leaflet free with devices (10p alone)

MC1310; 2, 4 & 5 Leaflet free with devices (10p alone)

LED DISPLAYS

Litronix Double Digit Displays
0.5" Common Anode; 2 R/H
Decimal Points
DL721 ± 1.9
DL727 0.0 to 9.9
Suitable for Clocks, Meters,
Instruments, Channel Indicators
Our price £4.75 * each

Low cost Red GaAsP	0.33" Litronix DL 707 Series	0.33" Monsanto MAN 50/70/80/3600	0.33" Xciton XAN 70 Series	0.43" Monsanto MAN 4000 Series	0.63" Litronix DL747 'Jumbo' Series
15p*					

DIGITAL SWITCH

BCD encoded digital switch
Reading 0 to 9. Suitable for
digital clock alarm setting
DVM input Scaling etc.

all £1.82* each (Red only)	all £1.82* Each (Red, green, yellow, Orange)	all £1.49* Each (Red, Green, yellow)	all £2.33* Each (Red, Green, Yellow, Orange)	all £2.42* Each (Red only)

LIGHT EMITTING DIODES

Free snap-on plastic retainer

0.125" dia. lens (TIL 209)	0.16" dia. lens	0.2" dia. lens (MLED 650)							
1+ 10+ 100+	1+ 10+ 100+	1+ 10+ 100+							
Red	16p	15p	13p	27p	24p	22p	18p	16p	14p
Green	27p	24p	22p	33p	30p	27p	30p	27p	25p
Orange	27p	24p	22p	33p	30p	27p	30p	27p	25p
Yellow	34p	31p	29p	35p	32p	29p	35p	33p	30p

Our Bulk Buying Power enables a repeat of our Special Offer:
0.33" (LIT 707) 90p. (inc. VAT)
0.63" (LIT 747) £1.99. (inc. VAT)

OPTO-ISOLATORS

ILL 4N25 or ILL116
6 pin industry standard package
2.5KV isolation £1.00.*

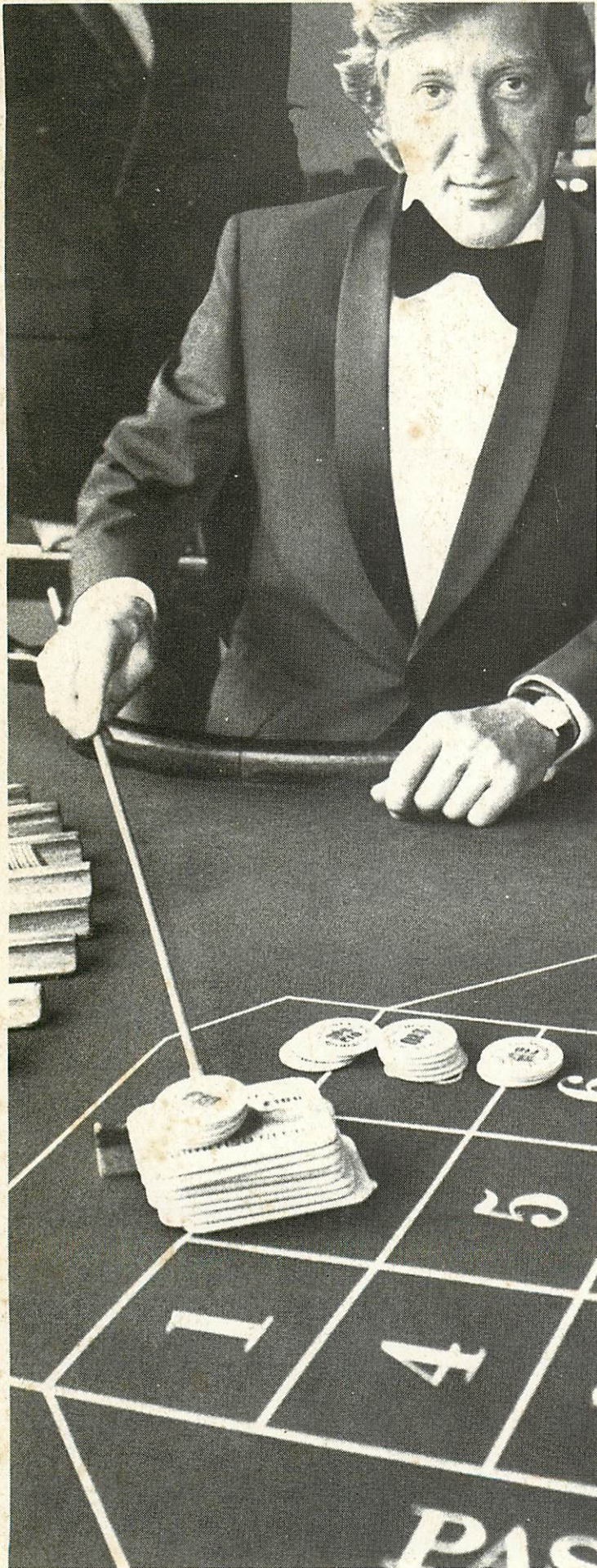

M6800 has taken the gamble out of microprocessors

Seven reasons why you'll always win with M6800.

1. **Programming language.**
So easily learned that it makes your transition to MPU's that much easier.
2. **Unlike competitive ranges, the M6800 family is capable of further development** while still maintaining upward compatibility.
Example: The M6900 series is now being defined to meet defined customers' requirements.
3. **Very efficient programme code.**
Wide instruction repertoire, including seven addressing modes.
4. **Sub-function devices already available.**
5. **Single power rail, 5 volt.**
6. **Interfaces easily with TTL and CMOS.**
7. **Second sourced by AMI across Europe.**

Here's the M6800 family today: —

MC6800	Microprocessor.
MC6820	Peripheral Interface Adapter.
MCM6810	Static RAM.
MCM6830	ROM.
MC6850	Asynchronous Communications Interface Adapter.
MC6860	Low Speed Modem.

Alternative N-Channel Si Gate RAMs for large systems: —

MCM68102	1K x 1	Static	16-pin.
MCM6814	4K x 1	Dynamic	16-pin.
MCM6815	4K x 1	Dynamic	22-pin.

Recent new devices include: —

Dynamic Memory Refresh Controller.

MCM68112A	256 x 4	Static RAM.	16-pin.
MCM68317	16K	Static ROM.	24-pin.

An 8K x 1 erasable and electrically reprogrammable ROM (MCM68708) was introduced in the first quarter of 1976. And there's more to come!



MOTOROLA
Semiconductors

Motorola Ltd. Semiconductor Products Division
York House, Empire Way, Wembley. Tel: 01-902 8836.