

elektor

up-to-date electronics for lab and leisure

D 71683

102

October 1983

85 p.

IR 123p. (incl. VAT)

\$ 2.75

AIR-MAIL COPY

Simple Self

- **simple anemometer**

- **music quantizer**

- **Basicode 2: BASIC for all computers**

READERSHIP SURVEY RESULTS



CONTENTS

readership survey results	10-21
selektor	10-24
Basicode-2	10-27
The fact that not all BASICs are created equal can cause some problems when you try to run a BASIC program written on one machine onto another. Basicode-2 is a standard devised to get around this problem.	
music quantizer	10-30
This music quantizer produces discrete voltage steps from a continuously variable input and should interest most 'electronic' musicians.	
solid-state dark room lighting	10-36
A new way of obtaining correct colour light for your dark room is the use of high-output LEDs.	
high-voltage regulator	10-38
This regulator tolerates an input/output voltage differential of more than 3 times the usual 40 V.	
anemometer	10-40
With the circuit described, the instantaneous windspeed can be measured, while the maximum and minimum windspeeds measured over a period of time can be stored.	
PCB pages	10-45
missing links	10-46
programmable power supply	10-49
We hook up a D/A converter to the input of a 723 and obtain a very precise output voltage.	
Basicode-2 interface for the Junior Computer	10-51
This article describes how the Junior Computer may be adapted for Basicode-2.	
electronic voltage regulator	10-57
This design will enable people with older cars to enjoy the advantages of electronic ignition.	
battery eliminator	10-60
This unit provides a stabilized output which is variable around $\pm 25\%$ from nominal at an output current of 250...300 mA and low ripple voltage.	
transistor selector	10-62
This selector will enable you to determine the class, as defined by the d.c. current gain, into which a particular transistor falls.	
FSKleaner	10-64
A useful device for processing 'messy' FSK signals.	
useful tip ... 2N3055 super Darlington pair	10-67
EPRoMmer using the Junior Computer	10-68
There are many benefits in being able to program your own EPROMs. We have made this job easier by combining the Junior Computer with our previously published EPROM programmer.	
aplikator	10-70
A new AM receiver IC from Ferranti, the ZN415, requires only a small number of external components to make a complete radio.	
market	10-73
switchboard	10-77
EPS service	10-88
advertisers index	10-90



A windspeed meter for all who want to know a little more about the weather than shown by the barometer which can be built by any electronic hobbyist. It measures the instantaneous windspeed and at the same time stores data relating to maximum and minimum windspeeds measured over a certain period of time.

Sumok Singh

A selection from next month's issue:

- doorbell-operated flashing light
- electronic metronome
- CPU card
- speed controller for model railway
- pseudo stereo
- decimal-to-binary converter for programmable pocket calculators
- outside thermostat for central heating system

The Plug says 'No' to dirty power.

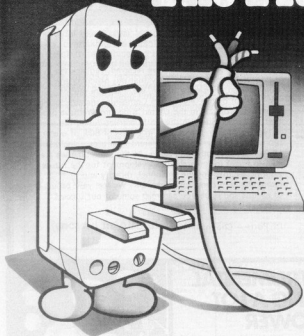

WHY

Because dirty power is the most likely cause of the unexplained errors and circuit malfunctions which can upset all micro based products and their users.

HOW

The Plug with its own built in filter and transient suppressor reduces the effect of electrical noise and spikes and increases the reliability of both hardware and software.

Protect your computer from unnecessary power problems, say 'No' to dirty power.

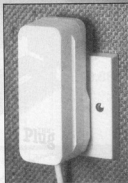

R.R.P. £15.50 including p.p.
Dealer enquiries welcome.

The Plug is available from dealers or direct from the manufacturer

FOR FURTHER INFORMATION CONTACT:

Power International Limited

Dept. EK, 2A Isambard Brunel Road,
Portsmouth, Hampshire PO1 2DU. Tel. (0705) 756715

WARNING: Unfiltered power can damage your computer's health.

ELEKTRONIC COMPONENTS

★ ELECTRONICS ★ COMMUNICATIONS ★ COMPUTING ★ VIDEO ★ AUDIO

★ 3 x £1 DISCOUNT Vouchers as usual

★ PRICE-ON-THE-PAGE

ambit
INTERNATIONAL

Adaptors	Copper Clad PCB	Generators	Screwdrivers
Aerosols	Coils	Helical Filter	SCRs
Ameters	Converters	High Pass Filter	Semiconductors
Amplifiers	Crystals	ICs	Silicon Compound
Audio Leads	Data Books	IF Transformers	Silicon Diodes
Auto Modulation Meter	Die Cast Boxes	Keyboard Switches	Silver Plated Wire
Batteries	Displays	Keypad	Soldering
Beads - Ferrite	Diodes	Keyswitch Caps	Stereo Decoders
Books - Technical	Dot Matrix LCD Module	LCD Displays	Switches
Bridge - Rectifiers	Double Balanced Mixer	LCD Modules	Type Mechanism
Bulbs	Drawing Aids	Lever Switches	Terminal Blocks
Cable	Drills	Linear ICs	Thermometer
Cable Accessories	Dress Cord	Linear Phase Filters	Transformers
Cabinet Feet	Earpieces	Low Pass Filters	Transformers Mains
Cage Locks	Enamelled Copper Wire	Mechanical Filters	Trim Tools
Capacitors	EPROM Eraser	Miniature Loudspeakers	Trimmers
Cases	Eching Kit	Miniature Relays	TV Filters
Cassette Mechanisms	Etch Resist Pen	Mixer Diodes	TV Modulators
Caps - Keypote	Ferrite Chloride	Ni-Cad Batteries	Variable Inductors
Ceramic	FET Dip Oscillator	Noise Measuring Equipment	Varicap Diodes
Cermet Preset	File Set	Ocilloscopes	Video Adaptors
Chassis Punches	Fixed Inductors	Opticalscope Probes	Video Leads
Chargers - Battery	Fluorescent Displays	PCB Aids	Volmeters
Chokes - Min Fixed	Function Generators	PCB	Voltage Regulators
CINEMASCOPE		Potentiometers	VU Meters
Clocking Blocks		Presets	Zener Diodes
Clocks - LCD		Quartz Crystals	Zero Insert Force Socket
CMOS ICs		Resistors	Z-8 Development Systems
Computer Leads		Resonators	
Connectors		Rotary Switches	
Coax Relay			
Contact Cleaner Aerosol			

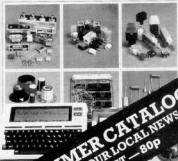

NEW SUMMER CATALOGUE!
AVAILABLE AT YOUR LOCAL NEWSAGENT
OR DIRECT - 80p

ambit INTERNATIONAL

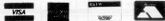

200 North Service Road, Brentwood, Essex CM14 4SG
Telephone (Consumer Sales/Enquiries) 0277-230909 — Telephone (Industrial Sales/Enquiries) 0277-231616 — Telex 995194 AMBIT G — Data 24 hrs (RS232/300 baud) 0277-232628; REWTEL

95194 Ambit G
Brentwood, Essex CM14 4SG

microprocessor HARDWARE



Elektor Publishers Ltd.
Canterbury
ISBN 0 856705 15 7

Are you looking for a terminal for your micro-processor . . . ? Or maybe a memory extension? Is your cassette interface too slow or just not good enough? Computer capacity underestimated? How do you program your (E)PROMs? All these and many other questions are answered in this micro-processor hardware book in clear and easy-to-understand language.

The heart of every personal computer is the micro-processor and only a limited number of these are in common use. This book describes a range of peripheral equipment which can be used with an assortment of personal computers using the 6502, 6809, Z80, or 8080 microprocessor. This is obviously not an easy matter, but the book explains all that is necessary to enable the systems to be applied with the minimum number of circuit modifications.

Price £7.50 + p & p: U.K. 50p/outside U.K. £1.00

To order please use the order card in this issue.

ELECTROVALUE

THE ELEKTOR
ENTHUSIAST'S
A-Z
BUYING GUIDE

It's amazing what you'll find in the pages of our current price list, be you beginner, expert or professional. The list below gives some indication of the enormous stocks we carry and our service is just about as good as meticulous care can make it. WRITE, PHONE OR CALL FOR OUR LATEST PRICE LIST NOW!

IT'S
FREE!

Please mention this journal when applying

Good Bargains
Good Service
Good Choice

- Access facilities
- Aerosols
- Batteries
- Boxes
- Boards
- Computers & Equipment
- Capacitors
- Connectors
- Discounts
- Electrolytics
- Ferrites
- Grommets
- Hardware
- I.C.s
- Knobs
- Lamps
- Meters
- Op-to-electronics
- Potentiometers
- Pot Cores
- Quantity prices
- Resistors
- Relays
- Semi-conductors
- Switches
- Solder tools
- Tools
- Transformers
- Vero products
- Via facilities
- Zener diodes

ELECTROVALUE LTD 28 St. Jude's Rd., Englefield Green, Egham, Surrey TW20 0HB. Egham 33603 (London 87: STD 0784) Telex 254475 (Northern Shop) (Callers only) 680 Burnage Lane Mchstr. (061 432 4945) Computing Shop 700 Burnage Lane Manchester 1061 431 4866

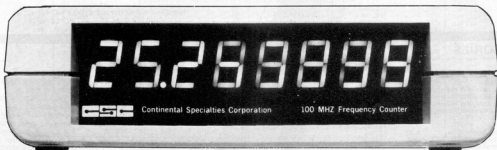

5 Hz TO 100 MHz

TOMORROW'S TOOLS TODAY

GLOBAL SPECIALTIES CORPORATION



G.S.C. (UK) Limited Dept. 2D
Unit 1, Shire Hill Industrial Estate,
Saffron Walden, Essex. CB11 3AQ
Telephone: Saffron Walden (0799) 21682
Telex: 817477

Instant frequency indication from 5 Hz to 100 MHz; no range selection problems; a brilliant 8-digit LED display; mains or battery operation; an accuracy of 4 parts per million \pm 1 count; and totally automatic operation — all this for only £ 105.00* with GSC's new Max-100 frequency counter.

Just take a look at our spec. Where else could you find anything similar at the price? *Frequency range 5Hz - 100 MHz *Input impedance 1M shunted by 10pF *Sensitivity 30mV from 1KHz up to 50MHz; 120mV r.m.s. over full frequency range *Timebase accuracy \pm 4 parts in 10⁶ (from 5 to 45°C) *Maximum aging rate 10 parts in 10⁶ per year *Over-frequency indication *Low-battery-power alarm *Operates from dry or rechargeable cells, an external 7.5 to 10VDC supply, or a car battery (via an adaptor) *Dimensions: 45 x 187 x 143mm *Options: 12V adaptor; battery eliminator; r.f. antenna, low-loss r.f. tap, carrying case.

Fill in the coupon for further details . . .

*price excludes post, packing and VAT

G.S.C. (UK) Limited, Dept. 2D, Unit 1, Shire Hill Industrial Estate, Saffron Walden, Essex CB11 3AQ

MAX 100	FREQ. COUNTER	Unit price inc. P & P 15% VAT £ 124.20	On-Hand
---------	---------------	--	---------

Name _____
Address _____

I enclose cheque/P.O. for £ _____ or debit my Barclaycard/Access/
American Express card no. _____ exp. date _____

FOR IMMEDIATE ACTION — The G.S.C. 24 hour, 5 day a week service.
Telephone (0799) 21682 and give us your Barclaycard, Access, American
Express number and your order will be in the post immediately.

For Free catalogue tick box

AN OSCILLOSCOPE & FUNCTION GENERATOR IN ONE PRECISION INSTRUMENT FOR JUST £295 plus VAT



Made in Britain

You can now buy a dual trace oscilloscope and function generator and have it delivered anywhere in the UK mainland for less than £300.

Or, if you have a Scopex dual trace scope, the function generator can be supplied separately for you to fit.

Only Scopex offers this total add-on compatibility.

SCOPEX FG Combined oscilloscope and function generator £295 plus VAT.

FG4, FG14/25 Function generator for mounting on Scopex dual trace scopes £69 plus VAT.

FG1 stand-alone function generator in instrument case £79 plus VAT.

SCOPEX

the oscilloscope people

Scopex Instruments Limited, Pixmore House,
Pixmore Avenue, Letchworth, Herts SG6 1HZ
Telephone (04626) 72771

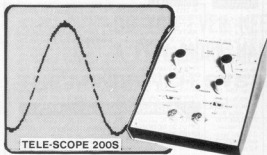

Digitise at up to 10 MHz. Store, then display on a UHF TELEVISION. Single shot Capture up to 250 KHz. Storage Facility for less than £100.

The Tele-Scope is a new concept in data capture utilising the latest Digitising techniques. The Tele-Scope acts — controls — displays much like a conventional scope but does much much more.

A kit version is available for £89 and a Built unit for £109. A manual is included and specialist parts are available separately.

Prices exclude V.A.T. at 15% with postage and packing at £2.95 inc. The manual is available separately for £1.50 inc. which is refundable on subsequent purchase of a unit.



NAME & ADDRESS

Cheques P.O. made payable, I enclose Cash £ p

HAWK ELECTRONIC TEST EQUIPMENT

Bircholt Road, Parkwood Industrial Estate, Maidstone, Kent ME15 9XT. 0622 686811

The VIA 6522 reveals its secrets



This new book is an indispensable addition to the four books already devoted to the Junior Computer, but it is not aimed

solely at Junior users but at anybody who has a system with one or more 6522s.

Make the most of your Junior: use every possible aspect of it. This VIA 6522 book will help you.

It will acquaint you with:

- the two bi-directional Input/Output ports of this Versatile Interface Adapter
- the operation of the two 16-bit Timer/Counters
- how the integrated Shift Register allows you to convert data from serial to parallel and vice versa
- the various handshake possibilities
- the detailed operation and programming of the VIA 6522 through numerous illustrations and tables

the practical introduction to a powerful system



VIA 6522



Elektor

Elektor Publishers Ltd.
Canbury
ISBN 0 905705 16 5

Price £3.25 + 50p U.K./£1.00 outside U.K. To order please use the pre-paid order card at the end of this issue.

Readership survey results

By and large, Elektor readers are male, in the 18-40 age group, and employed. More importantly, they are actively interested in practical projects they can build themselves. There's a 50/50 split between computer owners and computer-free households — but in the latter group there appears to be an even split between 'I wish I had one' and 'I'm glad I haven't'. Furthermore, the vast majority are curious to know what other readers think. So, here we go . . .

For those of you who don't know: we included a 'Readership Survey' in our July/August issue. The first question was: 'Are you interested in the results?' Some 80 per cent said 'Yes', and only 2 per cent said 'No, it's a waste of paper' (the rest didn't answer this question). To keep that 2 per cent happy, we'll try to keep it short . . .

"It took me exactly 20 min. 27 sec. to fill out this survey."

So far, we have had a response equal to 5 per cent of our readership. The replies are still pouring in, but the basic trends seem sufficiently clear. To avoid prejudice, we will first list the results obtained so far; then we will give our comments.

"I could do with more computer peripherals."

Likes and dislikes

Throughout Europe, the trend is similar; in the U.K., the various areas of electronics rank as follows:

- | | |
|-------------------------------------|-------|
| 1. Computer interfaces, peripherals | (58%) |
| 2. Digital (other than computers) | (55%) |
| 3. Measuring equipment | (51%) |
| 4. Audio/Hi-fi | (51%) |
| 5. Microcomputer construction | (50%) |
| 6. Microcomputer software | (40%) |
| 7. Domestic applications | (38%) |
| 8. Radio/HF | (33%) |
| 9. For other hobbies | (28%) |
| 10. For use in cars | (28%) |
| 11. Electronic music | (24%) |
| 12. Video | (20%) |

Noteworthy exception abroad: 'Domestic applications' rates first place in France (our French editorial staff have a simple explanation: 'You should know French women! How

else can you justify your hobby?'). The 'other hobbies' are mainly photography (10%) and trains, boats, cars, remote control, and so on (7%). The Germans add tropical fish, and the Dutch aren't into robotics yet.

"There should be more audio" . . . "More RF, please" . . . "More digital and video" . . . "How about radio control?"

Elektor contents

In general, practical information scores highest and 'practical news' takes second place. The survey ranked each feature from 'wouldn't read Elektor without it' through to 'waste of paper', and — to make things difficult — asked how many pages should be allowed for each. The results are revealing . . . The vast majority vote for 'nothing but' or 'more' practical projects (over 90%); practical information (85%); application notes (70%), info-cards (65%), and theoretical information (60%). Neutral ranked from positive to negative bias: Market, Selektor, Technical Answers, Ejelector, Editorial introduction/opinion, computer programs, readers' letters, book reviews, circuits for fun, and tests of commercial equipment. No feature is completely negative: even 'tests' scores 19% 'more', 37% 'neutral', and 43% 'less'.

"Include more computer hardware for other computers than the Junior."

However, the 'page rating' is significant; on average, our readers prefer the following content:

■ Selektor	3½ pages
■ Projects	27 pages
■ Practical information and theory	12 pages
■ Market	3 pages
■ All other features (!)	4½ pages

"There must be some great wits on your team. After all, what else is an engineer but a comedian with a soldering iron?"

Projects

Thank you very much — we're flattered! Seventy-five per cent of our readers build more than two projects per year — 30 per cent 'as described', and 60 per cent 'with a few modifications' (mainly to use

available components, fit a case, or tie in to other equipment). Component availability is 'no problem' (21%), or 'usually fairly easy' (54%) — only 3 per cent rate it as 'hopeless'. The projects usually 'work first time' (60%), or 'after some trouble-shooting' (40%) — 0.9 per cent say they 'rarely work at all'. If there is a problem, 88 per cent can 'usually', and 11 per cent 'sometimes', solve it themselves. Otherwise, they 'ask a friend for help'.

To our surprise, the vast majority own (and/or have access to) a wide range of measuring equipment: multimeter (110%), lab power supply (92%), oscilloscope (87%), tone generator (77%), and even frequency counter (70%).

"The PCBs are rather expensive, so I make copies."

Our p.c. boards are widely appreciated! In fact, 50 per cent claim that they prefer to buy them! (Would that it were so . . . but this is nonsense! We know how many we sell — nowhere near that many! Are you really buying our boards? You know, the ones on blue material, with black and white component and track screen, and solder mask? Not green epoxy, surely — we don't make those!)

Then, reliability 'compared to the competition'. We hesitate to say — 55 per cent consider our circuits 'more reliable', while 25 per cent say 'about the same'. We've got one per cent 'less reliable', and 19% 'don't know'. No comment.

"Your balance is very good. Don't change it!"

Buying habits

Since this section is primarily of interest to advertisers and our own commercial department, we'll be brief!

In general, complete kits are not in demand — only 16 per cent of our U.K. readers prefer this option. The other two options, 'components and PCBs separately' and 'only components' rate 43% and 45% respectively.

Roughly half our readers spend up to £ 100 per year on their hobby, the other half spend more; 25 per cent spend 'more than £ 200'. Abroad, the trend is similar — the

Table 1.

Magazine	Elektor (%)	'C' (%)	'G' (%)	'J' (%)	'H' (%)	'F' (%)	No. 1 Germany (%)	Joint Nos 1 France		No. 1 Holland (%)
								(%)	(%)	
Subscribers	55%	8	5	8	2	12	14	14	12	11
Regular readers	37	25	17	20	8	7	14	27	26	17
Occasional readers	7	37	46	36	37	26	43	47	50	44
Total	99	70	68	64	47	45	71	88	88	72
Very good	63	20	7	30	4	11	8	8	5	8
Good	31	34	31	37	27	27	32	35	18	39
Average	3	33	45	24	47	37	36	33	42	38
Poor	0.6	10	12	7	16	18	20	19	25	12
Very poor	—	3	5	2	5	7	4	5	9	3
Contents biased towards	You know!	Projects	Projects	News & Descriptive articles	Projects	Projects	Projects	Projects	Projects	Projects

Table 2

Other reading	U.K.	Germany	Holland	France
Specialist magazines	3.2	2.3	2.8	1.1
General periodicals	1.0	1.0	1.4	1.1
Daily newspapers	0.9	0.8	1.2	0.4

French and Dutch spend slightly less (60% less than £ 100). 'Professionally', we seem to spend (or authorize) astronomical budgets: 'more than £ 5000' rates 18 per cent in the U.K., and about ten per cent in France, Germany, and Holland. Even the most conservative estimate, based on these results, would be that we are spending at least £ 250 million per year!

What do you look for in advertisements? Components! (90%). Then microprocessors (43%), books (41%), measuring equipment (33%), tools (31%), and commercial equipment (20%).

"PS. The paper is good, too, and your ink is the only one that's black enough to photograph."

'All' (29%) or 'most' (60%) of the articles are read, and on average this takes 4½ hours — first time round. With all the reading and re-reading, we have found estimates of more than 100 hours! It surprised our editorial staff — and pleased our advertising manager! — to find that a similar trend applies to the advertising section. 'I check all adverts' rates 12 per cent, and 'I look through most of them' scores 45 per cent. On average this takes 1½ hours.

The questions relating to 'subscription' versus 'newsagent', 'since when are you a subscriber?' and so on, were intended as a check, to ensure that we were evaluating a representative cross-section of our readership. In practice, some correction proved necessary (subscribers were over-represented); the percentages given

in this article were modified accordingly. (Perhaps this was poor commercial policy; subscribers are slightly more 'pro Elektor', so the results would look even better if we hadn't corrected them . . .).

"What happens to your copy — do you 'pass it on, keep it, or throw it away?' Just as we thought: 97% keep it, two per cent pass it on, and only one per cent throw it away. More on this under 'comments' — both yours and ours.

"Corrections to previous issues should be given a prominent place. This is the acid test for a magazine. You pass . . ."

Reading habits

We asked how many other magazines you read, and how the electronics magazines score. The idea was to discover what kind of readers we have (as opposed to *electronic hobbyists*), and at the same time to evaluate your preferences — after all, we read those other magazines, too!

"Keep up the good work!"

We were pleased to find that 63 per cent of our U.K. readership consider Elektor 'very good', and 31 per cent 'good'. This gives us a reference for the others. It should not come as a surprise that the more practical-project oriented magazines are read more often. Furthermore, third place (out of fifteen) goes to a magazine

which is known for its high editorial standard. The actual percentages are given in table 1.

The reasons given for buying and reading Elektor follow the same trend. 'Interesting articles' and 'hobby' take first and second place throughout Europe. The 'professional appearance' comes third in the U.K. — but it ranks far lower abroad, where other magazines have a similar appearance. 'For want of something better' scores last-but-one in the U.K., but it takes third place in France — which says a lot about the other magazines in these two countries!

"Yes, computers have a future — but don't RAM them down our throats every month."

Readership profile

Just as we thought: the 'typical Elektor reader' doesn't exist! In the U.K., electronics is 'a hobby' for 34% and both hobby and profession for 58 per cent. All age groups are represented, although there is a slight bias towards the 20-30 group. At the extreme ends, 'under 17s' are slightly under-represented in the U.K. (three per cent as opposed to eight per cent throughout Europe); 'over 60s' account for 5% in the U.K. and 3% overall.

The question 'male or female' turns out to be redundant . . . we seem to be 99.9% male! In fact, we have received replies from only about half-a-dozen women — out of a total of close to ten thousand replies tallied so far!

About one third of our readers have no formal qualifications in electronics. At the other end of the scale, there are some 12 per cent 'corporate engineers'. There is a broad sweep in 'other education', through to 28 per cent with a university degree. Sixteen per cent are students — and 57% are employed ('not employed' rates three per cent in the U.K.). 'Do you own a computer?' 'Yes' scores 53% with over eleven per cent owning more than one. Of the devices listed, just over 40% are 6502-based and nearly 40% are Z80 machines. Sinclair wins hands-down, as you might expect; then there are quite a few Apples (mainly Apple II), BBCs (mainly model B), TRS80s (mainly model I), VIC 20s, Acorn Atoms, and NASCOMs.

"Keep computer programs and HiFi reviews to their own specialist mags."

Your comments (and ours)

Microprocessors in Elektor?

There are two noteworthy trends: 'Please, keep Elektor free from these pests — if I want programs, I'll buy a specialist magazine!', and 'Microprocessor hardware, OK, provided you don't waste too many pages on it and provided it's suitable for commercial machines'. Points taken — as regular readers may have noticed, your editor has already been doing his utmost to move that way: less on microprocessors, and what there is aimed at practical value for a maximum number of readers!

"I don't mind a bit of computer, but please mix it with some RF, audio, and digital."

Circuits and contents

Several comments were made by a significant number of readers (more than one per cent, that is):

- Please specify suppliers for awkward components, or use more standard components (BC 107, etc.) or list alternatives.
- Include test-points, etc., as an aid to trouble-shooting.
- Some indication of construction cost would be useful; also, more information on the type of case to use.

General comments

Apart from the pleasingly large group of 'I like Elektor' and 'Your p.c. boards are best', several other general comments scored over 1%:

"PPS. This paper is b awful to read in artificial light. Can't you go back to the pre-'76 stuff?"

- The printing and general appearance are far superior to other mags, but the older paper (pre-1977) was even better.
- A several-year cumulative index would be very welcome (that fits, given the fact that nearly everyone keeps his copies!).
- Please don't adopt the revolting trend of including adverts in the editorial section.

"Your PCBs are of superb quality and at reasonable prices. Don't ever do away with them!"

- Those special p.c. board layout pages are a great help (this scored 37% in the relevant question!), but don't use them as an excuse to delete the layout from the article proper. Lots of other comments didn't score so high, but they seem valid for everyone. For instance, just one reader so far has suggested that 'Missing Links' could be included on the p.c. board layout pages. That way, they can be cut out and pasted in the original article. Great idea! While on the subject of 'Missing Links', we received several further requests 'please, repeat them over several months', 'please, publish them sooner', 'please, print a year's index at regular intervals', 'please, include them on the contents page' . . . Also: 'Elektor circuits are error-prone — just look at all those Missing Links! That one appears at least as often as the more positive 'To err is human, but to admit it is noble'.

"Postage stamps cost more than transistors!"

One other comment ranks almost top of the list in the U.K. (but nowhere else!): 'This survey should be reply-paid'. Yes, we considered it — but when we did a few sums, we got cold feet! People with some experience in this field warned us that we could then expect upwards of 25% response. That would let us in for a postage bill for over £10,000! So, reluctantly, we politely asked each reader for a 12½p stamp.

Final note

We are often told that component availability is a problem, but the survey fails to confirm this. We

have a total response, for all countries, of 78% 'no problem', or 'usually fairly easy'. The U.K. figures are even more favourable than the overall picture: 21% 'no problem' as opposed to 17% overall. So where's the fire? After all, there's plenty of smoke! While reading through all the comments, we noticed several possible explanations:

- We have used a few awkward ones (the WD 55 is an often-quoted example), and these tend to stick in the mind.
- Many readers seem reluctant (partly for sound financial reasons) to order components by mail. In the local shops, however, a typical dialogue seems to run like this: 'A TCA 440, sir? Never heard of that. Who makes it? You don't know! Oh, I see, it's a circuit you found in Elektor . . . well, then, it'll only be available in Germany'. (This conversation was overheard by a reader, who notes that TCA 440s are readily available from Technomatic at £2.20).

"Do you intend to produce back issues of INFOcards or a repeat series?" (Answer: Yes!)

- Often, a special device will be available off the shelf in only a few shops. You can spend a small fortune in telephone bills trying to locate them.
- Readers often build circuits from four or five years back. In some cases, the components are then no longer available. So, what can we do about it? After all, we still have a good 20 per cent of our readers in the 'often a problem' category — and they're not all from Canada, New Zealand, or Taiwan. In future, we'll try to remember to add the manufacturer's name. Also, we'll try to work out a satisfactory way of giving a list of suggested suppliers, without playing favourites if we can avoid it.

"I live in Brazil and some components are not available here."

Finally, we wish to thank all those readers who participated in this survey. We have learnt a lot, and gathered several new ideas for improving the magazine. Now, let's see how soon we can put them into practice! ■

"Isn't it boring, going through all these comments? Merry Xmas!"

Discovering the infra-red universe

From an orbit 900 km above Earth, where it is unhampered by the atmosphere, the new infra-red astronomical satellite IRAS is revealing an exciting universe of previously unknown objects. Its 57-cm primary mirror is in the process of detecting important astronomical sources of infra-red radiation. It will increase a thousandfold the number of such sources known to us.

Infra-red radiation is a big part of the energy budget of the universe. Astronomers want to know its full significance in order to tackle a whole range of fundamental astronomical questions. But the problem is that water vapour and other gases in the atmosphere absorb infra-red radiation from space and emit it, too. It reaches the Earth's surface in only a few, narrow bands or 'windows'.

IRAS is now helping to solve this problem with an all-sky survey in the infra-red part of the spectrum. And it is detecting infra-red sources with up to a thousand times greater sensitivity than could be obtained by earlier observations from rockets, aircraft, balloons and ground-based observatories.

The infra-red spectrum stretches from the edge of red light, at a wavelength of one micrometre, to the beginning of radio waves at one millimetre; the

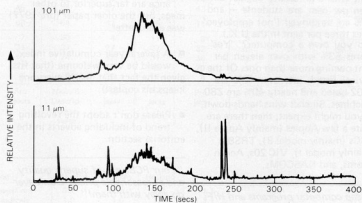

Scans of the Milky Way taken by the telescope on its first day of operation. The data came from a single 400-second sweep from South to North, 25 degrees long at an angle of about 45 degrees across the galactic plane in the constellation Crux, the Southern Cross. The upper trace is dominated by emission at a wavelength of 100 μm from cold dust within the clouds of gas that collapse to form the stars in the Milky Way; its jagged profile represents an integration of emissions from individual clouds of dust and gas hundreds of light-years across. The power trace shows intensity at a wavelength of 11 μm and is mainly due to emission from billions of stars; narrow spikes are caused by single stars that are bright or nearby. A bulge at the centre shows the most dense concentration of stars, while a slow rise at the right of the trace comes from warm dust in the plane of the solar system.

IRAS telescope is designed to detect infra-red wavelengths from eight to 119 μm . There are 62 rectangular detectors at the focal plane of the telescope; their composition and the way in which they are deployed enables astronomers to observe ob-

jects in four separate wavebands simultaneously.

IRAS has come into being through close collaboration by the UK, the Netherlands and the USA. The mission operations organization is the Rutherford Appleton Laboratory (RAL), near Oxford, where a 12-metre steerable dish sends commands to the satellite and receives observational and engineering data twice daily when it passes within receiving range.

Data stores

IRAS has a computer that controls the satellite and handles observation data. Two tape recorders on board can store up to 900 million bits of observational information for the RAL to receive at one million bits per second. All the satellite's systems are powered by solar panels, which supply 250 W.

Dutch scientists and engineers designed and manufactured the spacecraft, which weighs 266 kg. The 810-kg telescope was designed and built in the USA.

Observations and engineering data, as they come in from the satellite, pass through two computer systems to provide a constant supply of information on which control of the mission is based.

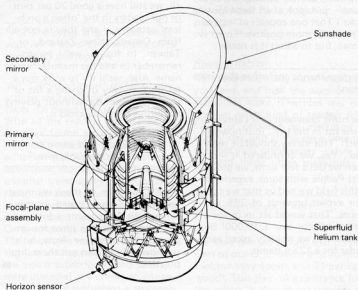

The IRAS telescope, a modified Cassegrain design. It has primary and secondary mirrors to reflect radiation on to detectors in the focal plane.

Frequency gap

Astronomers need IRAS to fill the gap between optical and radio astronomy. So far, infra-red astronomy has been used mainly to look at objects already observed at light and radio frequencies but which also emit in the infra-red region.

The frequency at which the radiation from any object reaches a peak depends upon the temperature. The higher the temperature the further the peak shifts towards shorter wavelengths, that is, higher frequencies. Most bodies that can be seen through an optical telescope have temperatures above 6000 K, which is about the surface temperature of the Sun. But while billions of objects, chiefly stars and galaxies, radiate strongly at the frequencies of light, there may be just as many cooler objects at temperatures from a few tens to a few hundred kelvin that radiate in the infra-red region. Without infra-red telescopes they could never be observed and studied.

For example, besides cool bodies there are hot, bright stars hidden from us by clouds of dust. Their light is absorbed by cloud particles

and re-radiated at infra-red wavelengths. Light cannot penetrate the dust clouds because the dust particles, about the size of particles of smoke, are larger than the wavelengths of light. But radiation at the much longer, infra-red wavelengths can pass through.

For this reason, the IRAS telescope can see to the centre of our galaxy, the Milky Way, which dust clouds hide from optical view. The galactic centre is a big astronomical mystery: although it occupies only about a millionth of the galaxy's volume, it radiates one tenth of the galaxy's energy. IRAS data should lead astronomers to a better understanding of what is happening there.

Other galaxies

Astronomers will also be able to compare our galaxy in infra-red with others. There are, for example, certain ordinary-looking galaxies whose radiation in the infra-red is about ten thousand times that coming from the centre of the Milky Way. How energy in this form is produced in

such vast amounts is at present unknown.

The very massive and hot stars that ionize vast clouds of hydrogen by their radiation are well known to astronomers. Only very intense radiation from massive stars could break apart the hydrogen of such clouds into protons and electrons. Because of their great mass, such stars last only for some millions of years, so their presence indicates that stars are being formed or that formation has recently taken place. Indeed, there are dust clouds of heavy elements in these regions where stars are being born.

The energy from the gravitational collapse of dust clouds is radiated as infra-red waves. The clouds become denser and hotter and proto-stars form which eventually begin thermonuclear reactions and blaze forth as new stars in the visible part of the spectrum. But, before this happens, astronomers can investigate star formation by observing the infra-red radiation produced. IRAS can detect proto-stellar objects with the mass of the Sun over a substantial part of our galaxy, so enabling astronomers to calculate the rate of star formation.

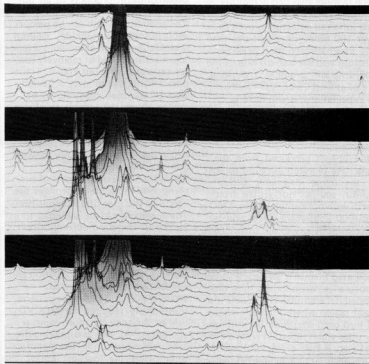

Three scans across the large Magellanic Cloud, the nearest galaxy to ours, taken by IRAS. Each scan records outputs over 75 seconds from 15 detectors on a wavelength of 60 μm during the first day the telescope was exposed. Dozens of sources of radiation are revealed, many invisible to optical telescope. Most are probably newly-forming stars. The intense emission left to centre may be from a star thousands of times more massive than the Sun.

Synthesized elements

The more massive a star, the shorter its life. A star more than three times the mass of the Sun, for instance, consumes its substance in nuclear reactions at a rate proportional to the cube of its mass. But, during their life-cycles, stars synthesize all elements heavier than helium; and in its old age a star ejects its synthesized elements as a shell of dust which absorbs light from the star and re-radiates in the infra-red region. In this way stars give back to the interstellar medium matter that they have transformed, which in turn forms into new stars and any planets they may have.

So IRAS will contribute to our understanding of how interstellar dust is consumed in the processes of star formation, and resupplied by very old stars. Astronomers plan to find out what proportion of matter stars lose at the end of their lives and to calculate the rate of ejection of new matter into space. For example, recent research shows that silicates are a dominant constituent of interstellar dust, so that by observing at appropriate infra-red wavelengths astronomers can map the distribution of silicates in our galaxy.



IRAS control centre at RAL, responsible for monitoring the status of the satellite and collecting data from its primary telescope and other experiments. The satellite passes over the centre at least twice daily. Incoming data gives scientists a brief check on objects that have been observed and controllers can make checks on the spacecraft itself. Data is sent to the Jet Propulsion Laboratory for complete processing.

Cooling

The main technical problem in observing the infra-red universe, quite apart from the need to rise above the atmosphere, is the need to keep the telescope cool. All objects more than just a few degrees above absolute zero radiate some energy in the infra-red range (and that of course includes the satellite, the telescope and everything associated with them), so the big engineering problem was to keep the telescope as cool as possible in order to detect the faintest infra-red sources. Obviously, anything fainter than the infra-red radiation from the telescope itself cannot be detected.

The detector package at the focal plane of the telescope, with its 62 rectangular detectors, is kept at about two degrees above absolute zero by surrounding the telescope with a tank containing 475 litres of superfluid helium. It is the run-down time of the cooling system that limits the working life of IRAS.

Data received

Following the launch by NASA from the Vandenberg base in California on 26 January, the satellite was placed in its nearpolar orbit to circle Earth 14 times a day. Engineering tests confirmed that all systems on board worked correctly and, on 31 January, the protective cover of the telescope was ejected. Within an hour the first infra-red images from outer

space were received, and during the first day over 4000 infra-red sources were detected, about the same as the total number that had previously been seen at such wavelengths.

The infra-red detectors proved to be over 100 times more sensitive than any that had been used in earlier missions and the boil-off rate of the liquid helium promises a working life of at least 250 days — well up to expectations. It will be long enough for astronomers to obtain a detailed all-sky catalogue of infra-red sources and to make their special observations.

First images produced from the data have revealed infra-red sources in the Large Magellanic Cloud (LMC), sources not visible from Earth with optical telescopes. LMC is 155 000 light-years away, and is the closest galaxy to our own. From a nebula of gas and dust within the LMC known as 30 *Doradus*, an image has appeared of a cloud with long, separated filaments giving it a spidery appearance: astronomers have nicknamed it Tarantula. The nebula is a giant region where there are clouds of hydrogen that have been ionized by ultra-violet radiation from a very hot star. A new cluster of massive stars, each 10 to 100 times as heavy as the Sun, has probably been born there recently; some astronomers have suggested that the nebula contains a monster star, thousands of times more massive than the Sun.

Edward Ashpole SPECTRUM 183

Better way of depositing semiconductor compounds

The metallo-organic chemical vapour deposition (MOCVD) process, used for depositing very thin ultra-pure layers of semiconductor compounds on to substrates, has been made very much safer and less expensive by the development in Britain of a range of completely new compounds which do not have the toxic, explosive and reactive-with-the-ambient characteristics of existing compounds. Moreover, these improvements have enabled the manufacturer to develop greatly simplified deposition equipment, which is said to be substantially lower in cost than existing equipment.

Key to the improved process is the use of solid adducts which are much more stable than the metal alkyls traditionally used for MOCVD. This is of particular significance to the electronics industry where the current use of highly reactive materials involves hazards in preparation, purification and handling. Side reactions when using conventional alkyls also present problems and can yield decomposition products in an uncontrolled way.

The adducts — which can be precursors for indium phosphide, gallium arsenide or gallium aluminium arsenide — are vaporised at relatively low temperatures of about 100°C. Transport of the vapour over a heated slice of the bulk substrate to be coated allows the organic enveloper to decompose leaving the inorganic constituents as an epitaxial deposit. Two or more compounds may be decomposed simultaneously to yield a third compound.

Selection of the organic part of the compound molecule determines the volatility and ease of decomposition. The molecule can be designed to yield pure metal on decomposition or to form a carbide nitrate, oxide, sulphide or other required derivative. Hence applications in protective coatings, and electrical insulation and conduction are also expected.

The complex and expensive systems traditionally required for MOCVD can be replaced by much simpler equipment. As well as supplying the precursor compounds, the manufacturer offers the low-cost Epitor 01/1S deposition system. Further savings are possible because the adduct precursors can be purified more simply and effectively as a result of their diminished reactivity.

Made in Britain.

The majority of modern hobby computers use the programming language BASIC. However, that does not mean that a BASIC program can be exchanged between two different types of computers, either directly or via a cassette. The BASIC commands may well be the same but the way in which the computer deals with them and how they are put on cassette are often completely different. Basicode was developed to solve this problem. It is a sort of universal communication standard to allow BASIC programmes to be interchangeable between different types of computers.

basicode-2

a code to
make BASIC
programmes
exchangeable

It is about two years since NOS, the Dutch broadcasting company, came up with the idea of developing a standardised code to make it possible to exchange BASIC programs between two different types of computers. As with most things that Murphy gets a hand in, this is not entirely straightforward. First of all there is the problem of storage on cassette. Most hobby computers use cassette recorders as a means of storing programmes. The method of registering data on tape and the frequencies used are different for each type of computer. A second difficulty is the BASIC language used. Even though a standard BASIC exists, each computer uses a different 'dialect' with its own peculiarities. There is also a problem as regards how programs are stored and processed within a computer, as there is no international agreement on this. Because of these factors BASIC, even though it is widespread, is not at all interchangeable between two computers that 'think' differently.

The Basicode standard is a fixed audio code by means of which BASIC programs can be stored on cassette. Through this standardisation, programs can be written onto cassette from any type of computer and read back to any type of computer. That is not to say that Basicode is simply a translation programme to store BASIC programs on tape in a specific manner. Just as important are the agreement on the BASIC commands used, the arrangement of line numbers, the names of variables and the screen format.

At present there is already a second version of Basicode available that uses a series of standard subroutines. At the same time a few other points have been changed from the original version with the aim of making Basicode even more universal. This Basicode-2 is the subject of this article.

Basicode on tape

Basicode uses frequencies of 1200 and

2400 Hz. A logic '0' corresponds to one whole period of 1200 Hz while a logic '1' is two full periods of 2400 Hz. Each byte is transmitted serially at a rate of 1200 baud, and every byte is built up as follows (see also figure 1):

- 1 start bit (logic zero)
- 8 data bits, least significant bit first
- 2 stop bits (logic one)

The BASIC programme is coded character by character in the form seen when a LIST command is given. No internal computer notation is used. All letters and figures are simply represented in ASCII code. Every BASIC instruction must be followed by a space, and each BASIC line must be finished with CR (carriage return, 8D_{hex}). The most significant bit of every ASCII sign is made '1'.

A complete programme on tape consists of the following sections:

- a leader consisting of a 5 second tone of 2400 Hz
- the ASCII sign 'start text' (82_{hex})
- the BASIC programme in ASCII code
- the ASCII sign 'end of text' (83_{hex})
- a 'checksum'
- a trailer, consisting of a 5 second tone of 2400 Hz.

The checksum, which is used for error detection, consists of a bit-by-bit exclusive OR function of all previous bytes (including the 'start text' sign). This checksum is 8 bits long (1 byte).

The Basicode-2 protocol

General agreements

The only BASIC statements allowed are those which are known by all computers. These statements are listed in table 1, and we will return to this later. A number of line numbers are reserved for special defined subroutines. This ensures that certain operations are possible that cannot easily be achieved in standard BASIC. These routines are not transmitted with the pro-

gram, so they must either be a part of the Basicode translation programme or they must be written in separately before RUNNING a BASIC programme.
 The screen dimensions are fixed at 24 lines of 40 characters. Because some computers have less than 24 lines on the screen or less than 40 characters per line, it is recommended that no more than 16 screen lines be used and that the lines should be kept as short as possible.
 A program line, including line number, spaces and carriage return, can have a maximum of 60 signs.

How a program is built up

The following groups of line numbers are reserved in Basicode-2:
 0-999: standard routines. These are specially developed for the computer in question and are supplied through the translation programme or are read in separately.
 1000: the first line of the program. It must have this form:
 1000 A= (value): GOTO 20: REM program name (value) is the maximum number of characters that are used together in all strings. By jumping to line 20, the computers that need it reserve some memory space for the strings.
 1010: the first line that can be used for the program.
 1010-32767: space for the program.
 There is no compulsory system within the programme, but the developers of Basicode recommend the following groupings:
 1000-19999: main program
 20000-24999: subroutines for the programme, in which statements exist that are not permitted in Basicode-2
 25000-29999: data statements
 30000-32767: REM statements. These can be a description of the program, references or the name and address of the programmer.

It is recommended that the line numbers are increased in steps of 10. As regards the subroutines at lines 20000-24999, these should be avoided as much as possible. If this is not possible, it should be made perfectly clear what each subroutine does.

Standard subroutines in Basicode-2

These subroutines are very much dependent upon each particular computer so this is just a general description of the function of the subroutines with no examples given.

GOSUB 100: This clears the screen and places the cursor at position 0.0 (upper left corner of the screen).

GOSUB 110: Set the cursor at a specific place on the screen. The desired location must be stored in variables HO and VE. HO is the position in a line (0 is completely left) and VE gives a line number (uppermost line is number 0). As the screen format in Basicode-2 is 40 characters on 24 lines, HO cannot be greater than 39 and VE no bigger than 23. The values of HO and VE do not change by calling this subroutine.

GOSUB 120: The position of the cursor on the screen is set in the variables HO and VE. With this system HO = 0 is the first position in a line and VE = 0 is the top line. This routine can be used with the previous one to, for example, move the cursor one or more lines higher or lower.

GOSUB 200: See if a button is pressed and store the value of this key in IN\$. If no key is pressed at that moment, IN\$ is empty. In principle, control characters could also be stored but this requires caution as these have different meanings for different computers. One exception is RETURN, which is ASCII code 13 in all computers.

GOSUB 210: This routine waits until a key is pressed and stores the value in IN\$. This routine actually waits for a key to be pressed, whereas in the previous one a value was only stored if a key was pressed at the actual instant when the routine was running.

GOSUB 250: This subroutine gives a bleep in computers that have this facility. The frequency and duration of the bleep are not specified here.

GOSUB 260: An arbitrary number between 0 and 1 is generated and stored in variable RV.

GOSUB 270: The whole variable space is cleared up and the routine finds out how much memory space remains (the variables are not cleared!). The number of free bytes is stored in variable FR.

Figure 1. This is how the transfer format is built up in Basicode. Note that transfer begins with the least significant byte.



Byte build up:
 Example: D9_{hex} (ASCII 58 with "1" as the eighth bit)

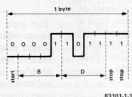

83101-1-1

GOSUB 300: The value of variable SR is stored as a string in SR\$. The string cannot contain a space at the beginning or end of a number. This is in contrast to STR\$ which does this sometimes. STR\$ is not permitted as a Basicode-2 statement in any case.

GOSUB 310: This routine supplies a string SR\$ built up as follows. The value of SR\$ is equal to the contents of variable SR and is always in fixed-point notation. The total length of SR\$ contains CT characters and the number of characters after the decimal point is defined by CN. If the number does not fit in the stated format SR\$ consists of CT asterisks. CT, CN and SR are not changed by calling this routine. An example of this routine is: CT = 7, CN = 3 and SR = 0.6666, then SR\$ = ' 0.6667'.

GOSUB 350: Prints SR\$ on the printer but does not finish the line yet. This makes it possible to print different strings one after another on the same line.

GOSUB 360: Closes a print line with a carriage return and new line command.

Variables

To ensure that the interchangeability of programs is maintained, there are some limitations as regards the variables used in any program:

- Numeric variables are always real and with single precision.
- The name of a variable can only have a maximum of two characters, and the first must be a letter. The second may, depending on use, be a letter or number. String variables have a \$ after the name. Lower case letters are not permitted in a variable.
- Logic variables can only be either true or not true. Any value that could be confused with something else by the computer may not be used, for example +1 for true and 0 for not true.
- It must not be assumed that all variables are reset to zero at the start of a programme.
- String variables can be no longer than 255 characters.
- Variables may not begin with the letter Q, as this is reserved for the standard subroutines.

- Variables AS, AT, FN, GR, IF, PI, ST, TI, TIS, and TO may not be used.
- The variables HO, VE, FR, SR, CN, CT, RV, IN\$ and SR\$ are used for communication between the BASIC programme and the standard subroutines.

BASIC limitations

Table 1 gives a summary of all the permitted BASIC commands and operators. Here some basic agreements are necessary. There are some variants in the BASIC language but usually the meanings of commands are much the same as in the official BASIC, so we will not discuss the variations here.

There are, however, a few points about BASIC commands that do require clarification. A variable name may not be used directly after a GOSUB or GOTO; so A = 1000 : GOTO A is not permitted. The command IF must always be followed by THEN. For example: IF ... THEN A = 5, IF ... THEN 1000 and IF ... THEN GOSUB 20000. The form IF ... THEN ... ELSE is not allowed. Comments or multiple variables are not permitted after an INPUT; so INPUT 'The value is'; A\$ is forbidden. A line number may not be given after RUN. If using the TAB statement, remember that some computers start counting at zero and others begin at one.

In practice

Those are the most important points about Basicode-2. Apart from these, a translation program and the 'permitted' subroutines are needed but we will not give them here because they are different for each computer. The translation program is in machine code and sometimes has a BASIC part, depending on the type of computer. There are already programs available for various different types of computer, and generally a specialized computer club can help here. If everything went according to plan, the Basicode-2 book is already available, giving the complete Basicode-2 protocol and several different translation programmes for common types of computer. Further information can be obtained from Hans G. Janssen, Hobbycoop, Postbus 1200, 1200 BE Hilversum, The Netherlands. The Basicode-2 book itself, which is printed with English and Dutch in the same book, is also available from Hobbycoop. Basicode programs are also broadcast during the Hobbycoop programme on Sundays from 17.10 ... 17.45 GMT (summer) or 18.10 ... 18.45 (winter) on 747 kHz. Finally, to return to our own Junior Computer. Elsewhere in this issue we have an article giving the translation programme and various subroutines for the BASIC Junior Computer. Translation programmes for both the expanded Junior and the DOS junior are available and this article has both of them!

Table 1. These are the permitted BASIC commands and operations.

ABS	DIM	INPUT	NOT	RETURN	STOP
AND	END	LEFT\$	ON	RIGHT\$	TAB
ASC	FOR	LEN	OR	RUN	TAN
ATN	GOSUB	LET	PRINT	SGN	THEN
CHR\$	GOTO	LOG	READ	SIN	TO
COS	INT	MID\$	REM	SQR	VAL
DATA	IF	NEXT	RESTORE	STEP	
+	↑	<>			
-	=	<=			
*	<	>=			
/	>				

The theory of electronic music synthesis is largely based on the characteristic of 1 V/octave, which has been used so much over the years that it is now almost universally accepted as the standard. This characteristic defines the relationship between a musical unit (the octave, which is the interval between two frequencies, one of which is twice as large as the other) and an electrical unit (the volt). Because the octave is composed of twelve equal semitones, the volt is also divided into 12 equal fractions. In this way a specific voltage always exists for each note in every octave. This control voltage then feeds various synthesizer modules (principally VCO and VCF) in steps of 83.33 mV, or multiples of this 'step'. The quantizer described here is used to produce control signals which agree with this characteristic given a signal that is not broken up into steps of 83.33 mV, no matter what its origin! That means that the tonal range which can be generated is almost infinitely variable.

music quantizer



analogue/digital converter +
transcoder + digital/analogue converter = control of
musical scales

This quantizer is not a generator, it is more like an interface between two other synthesizer modules; in fact, it could be better called a converter or transcoder. That means that it is supplied with one signal and it outputs a different one. There is, of course, a relationship between the two signals, the output is a quantized version of the input; this output, then, is 'chopped up' into the famous V/octave characteristic so that it produces the different steps of a musical scale defined by the user.

Figure 2 shows the relationship between the input and output signals of the quantizer. Here we see the curve of the input signal (in this example it is an envelope, but it could originate from a LFO, a sequencer, a pedal . . . or whatever), and two examples of output signals from the quantizer (QOV = quantizer output voltage). One of these contains all the notes in the musical scale and follows the input quite closely. The other signal, however, contains only the three notes of the major chord.

'Quantized! What does that mean?

The word 'quantizer' comes from the combination of 'quantizer' and 'synthesizer'. Quantizing is a process by which a physical size is divided into discrete values which are multiples of a fixed, non-reducible unit. In our case this unit is the musical semitone or the corresponding 1/12 of a volt (83.33 mV). The circuit described here has two fundamental modes of operation (with numerous variants that we do not have the space to

deal with here): one with transcoding or range-changing, and the other without. In this latter case, the quantizer is no more than a precision analogue/digital converter. A voltage applied at the input is converted into a digital value, which is immediately reconverted into an analogue value.

This procedure allows a curve to be modified to the usual V/octave characteristic, or alternatively a characteristic of $Y \times 1 V/octave$ could be converted to the standard 1 V/octave, always assuming, of course, that the input signal has the correct degree of accuracy ($\pm \frac{1}{2}$ LSB). Possibly more interesting for μP owners is the fact that the quantizer without transcoding provides two good quality, independently addressable converters on the same board.

The other mode of operation is far more spectacular, in so far as it permits some sort of musical order to be assigned to even the least musical of control signals.

Figure 1 shows the block diagram of the quantizer, consisting of six successive stages for processing the signal. An input amplifier for weak signals also ensures that the alternating signals have d.c. offset compensation. This is followed by the analogue/digital (A/D) converter, which has its own clock. Every 63 μs this converter provides an 8-bit digital code whose magnitude is proportional to the amplitude of the input signal. This data is then stored in a latch (ideally an addressable latch as this would enable the A/D converter to be used with a microprocessor independently of the rest

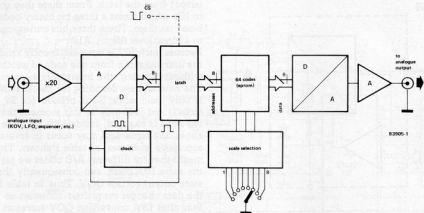

of the circuit). This same eight bit code is applied to an EPROM as the low byte of an address. Each address contains some specific data that is input to the D/A converter, the output of which is proportional to the magnitude of the digital code. The whole significance of the quantizer lies in the choice of these codes. The high order bits for addressing the static memory are supplied by a musical scale selection circuit that is accessible by the user. The memory area is divided into eight zones, allowing trans-coding to 8 musical scales.

Converting to digital form

Part of the circuit for the quantizer is shown in figure 4. This shows input amplifier IC1, A/D converter IC3, latch IC4 and clock IC2. The signal is input to R4 and thereafter to the non-inverting input of IC1, after being offset by a d.c. voltage set by P1. The A/D converter can only deal with positive voltages. Of course, many of the signals in a synthesizer are alternating voltages (from an LFO for example). The gain of this amplifier is set by means of P2 and can be between twenty and unity. Thus, with this input circuit, the quantizer is truly universal.

The amplitude of the signal is limited by P3 before the ZN 427 (figure 3a shows the simplified internal diagram of this IC) converts it to digital form. As the internal reference voltage of IC3 is 2.5 V, the maximum possible value of input signal is the same. This IC also needs a clock signal (to pin 3) and a start conversion signal SC (pin 4). The clock generator circuit (N1) provides a signal of 140 kHz. The start conversion signal is a combination of the clock signal and the end of conversion signal, provided by the ZN 427 itself and inverted by N4 before being applied to flipflop N2/N3. With this configuration, the end of each conversion causes the next one to begin, as the diagram of figure 3b shows.

At the start of the conversion, the highest order output bit, 7, (note: contrary to our normal designation the manufacturer of the ZN 427 calls it bit 1) is set to logic high and all other bits are set logic low. The voltage to be converted, V_{IN} , is compared with a voltage equal to $\frac{1}{2} V_{REF}$ output from the D/A stage of the ZN 427. The logic level of

bit 7 is established definitely at the next successive falling edge of the clock signal. It is high if $\frac{1}{2} V_{REF} < V_{IN}$ and low if $\frac{1}{2} V_{REF} > V_{IN}$. At the same time the following bit (bit 6) is set logic high and its logic value is determined on the next trailing edge as a function of a comparison between the output of the D/A converter and the voltage to be converted.

This procedure is repeated until the logic levels of all eight bits have been set. Immediately after the value of the lowest order bit is established, the EOC output of the IC goes logic high and the digital data appears as the output at the buffers of the converter and it remains there until the new start of conversion signal arrives. This whole sequence takes nine clock pulses. Because the clock cycle is $7.1 \mu s$ duration (the frequency is 140 kHz as we said), the total conversion time is $63 \mu s$, which means that the frequency of the sampling signal is 15 kHz. That is more than enough for VLF (Very Low Frequency) and non-periodic signals. But . . . it is a bit low for audio signals (the sampling frequency should be at least twice the highest frequency of the signal to be converted). However, with the minimum conversion time guaranteed by the manufacturer of the ZN 427, $15 \mu s$ (with a clock signal of 600 kHz), the sampling frequency is about 60 kHz! Admittedly this has little to do with the quantizer but the qualities of the circuit merit their being brought to your attention, possibly for future experimentation.

Figure 1. The quantizer consists of a chain of elements for processing synthesizer control signals. It is of interest not only because of the accuracy of its V/octave characteristic but also its ability to generate control voltages calibrated according to musical scales or chords. As far as the ear is concerned it is like a type of 'sequencer-arpeggiator'. Both the A/D and D/A converters can be used independently.

Figure 2. For any given input voltage the quantizer can deliver eight different output curves, each of which follows a certain musical scale. In the example shown here the light dotted QOV follows the chromatic scale, and the heavy dotted QOV voltage only gives the notes of the major chord.

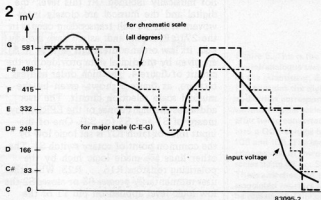

Figure 3a. This is the simplified internal structure of the ZN 427-E8 analogue/digital converter IC from Ferranti. The two important stages are the digital/analogue converter controlled by an external clock and the comparator whose inputs are the output voltage of the D/A converter and the voltage to be converted, V_{IN} .

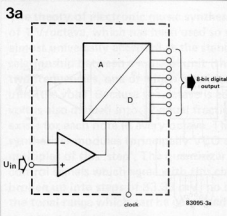
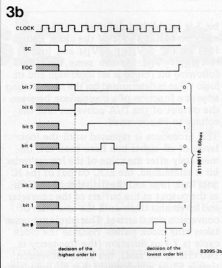

Figure 3b. This is a diagram of the signals during a conversion cycle of the ZN 427. The conversion time is always the same (nine clock cycles) no matter what the value of the voltage to be converted. In our example, the end of conversion pulse emitted by the converter itself produces a new start-conversion pulse.



We intentionally chose an addressable latch with high impedance outputs for IC4. When pin 1 of a 74LS374 is logic high its outputs are 'invisible' to a μP bus to which they are connected. An input has also been provided for an address decoding signal (AD) so that this first section of the quantizer is autonomous and could even be connected directly to a computer bus. In this case the jumper marked with a * must be removed.

Transcoding

Now that we have the digital code things are starting to become a bit more musical... and a bit more involved for those who are not musically inclined. At this level, the digital and the musical are closely interwoven. What we call transcoding occurs in the 2716 EPROM, and, as we have already said, its low order address bits (bits 0...8) are given by the digital data provided by the circuit of figure 4. The high order address bits are, as figure 5 shows, given by the musical scale selection circuit. The user addresses the eight zones of the EPROM by means of S1 and S3 (or S2). One of the input lines of latch IC7 is set logic low by the common point of rotary switch S1. The other lines are made logic high by the polarising resistors R16...R23. When the user momentarily presses S3 or closes S2 the low logic level applied on pin 11 of the 74LS373 causes these logic levels to be

output from the latch. From there they go to IC6 which forms a three bit binary code based on them. These three bits correspond to address lines A8...A10.

Because latch IC7 is not permanently valid, the user can jump from one code to another without 'hearing' the intermediate codes. The new address decoding for the EPROM is only valid while S3 is pressed (or S2 closed) and it is only at this moment that the zone is changed. Inside each of these zones, the same data may occur in several successive addresses, as table 1 shows. This means that for different A/D codes we get the same D/A code, and consequently the same output voltage QOV. Thus, in table 1a the data changes every four addresses so that after D/A conversion QOV increases by 83.33 mV. With this code all the degrees of the chromatic scale are present.

This is the first zone of the 2716, and is accessed by switching S1 to position 0. If we switch to position 1, we are in a different zone in which not all the chromatic degrees appear (table 1b). In fact it is the major scale, or if you prefer, only the white keys on a piano keyboard. Now the QOV voltage no longer changes by 83.33 mV, but by multiples of this value: first there are two full tones, then a semitone, etc.

It is also clear that there is an order of precedence between the various degrees. In the example of table 1a (the chromatic scale) there were four addresses per note, whereas in table 1b note D has six addresses, while note F has seven and notes C and E each have eight. This implies that the voltages producing these last two notes have statistically more chance of appearing as the QOV output than the former two.

If switch S1 is turned to position 2 (and S3 is pressed) the QOV output is the voltage corresponding to the scale of black notes on the piano (the pentatonic scale). Table 1c is a summary of the organisation of the zones of the EPROM and shows the other scales and musical ratios available.

For the same input signal there are various outputs available from the quantizer, as is shown in figure 6. Here we see that for the same LFO triangular signal input, the musical phrase output depends on the position of S1.

So we have: tonic C major (S1 = 3), dominant G major (S1 = 5), sub-dominant F major (S1 = 6), the complete major scale (S1 = 1), the chromatic scale (S1 = 0), the pentatonic scale (S1 = 2), and to finish this example, the relative minor chord (S1 = 4). This diagram also indicates when S3 has to be pressed after changing the position of S1. The data appearing at the output of the EPROM are applied directly to D/A converter (IC8) and this is straightforward, so it requires no further comment. The output stage is a buffer with offset compensation, using P5, and with a 10 turn pot (P6) for controlling the 1 V/octave characteristic.

Options

We have already mentioned that the transcoder does not have to be used, so if this is the case, EPROM IC5 should be removed. If the aim is to construct a precision A/D-

Figure 6. If S3 is pressed at the lowest point of the control signal (triangular output of an LFO) and the position of S1 is switched between two hollows, you change smoothly from one scale or chord to another. It is obvious that the musical phrase follows the contours of the control signal but the degrees are different and occur in greater or lesser numbers for each scale. This, of course, has an effect on the rhythm which is slower if there are less degrees present.

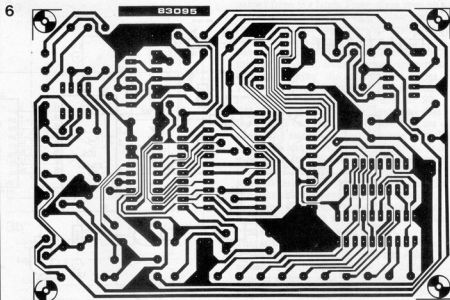

Parts list

Resistors:

R1, R2, R5, R6, R8 = 5k6
R3, R4 = 100 k
R7, R24 = 680 Ω
R9 = 680 k
R10, R14 = 6k8
R11, R13 = 390 Ω
R12 = 180 k
R15 ... R23 = 10 k
P1 = 4k7 lin.
P2 = 100 k lin.
P3 = 25 k 10 turn pot
P4 = 1 M 10 turn pot
P5 = 10 k 10 turn pot
P6 = 10 k 10 turn pot

Capacitors:

C1 = 10 n
C2, C5 = 1 μ (MKT)
C3, C4, C6, C7 = 100 n

Semiconductors:

D1 = 1N4148
IC1, IC9 = 741
IC2 = 4093
IC3 = ZN 427-E8
(Ferranti)
IC4 = 74LS377 (74LS374;
see text)
IC5 = 2716 (pre-
programmed, see text)
IC6 = 74LS148
IC7 = 74LS373
IC8 = ZN 426-E8
(Ferranti)

Miscellaneous:

S1 = single pole 8-way
rotary switch
S2 = single pole single
throw switch
S3 = pushbutton (push to
make)

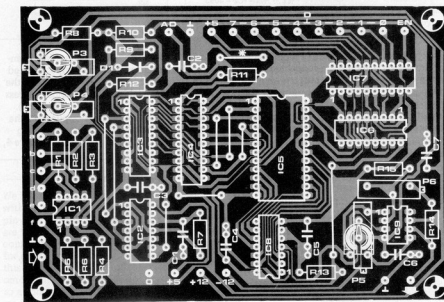

pin 1 of IC4 = 74LS374).

There is a further option: leave out S1 ... S3 and R16 ... R24 and control the musical scale selection circuit via the output port of a micro computer!

Construction and adjustment

There should be no problems with constructing this circuit, particularly if the printed circuit board design shown here is used. One important point to note, however, is that resistors R16 ... R24 are soldered directly to the pins of rotary switch S1. The 2716 EPROM is available pre-programmed from Technomatic Ltd.

Adjusting this circuit begins with setting the output buffer (after the usual checks, of course). IC5 is removed from its socket and pins 1 ... 3 and 9 ... 13 of IC8 are connected to earth. The output of the IC should be zero. The output of IC9 (pin 6)

should also be zero. If this is not the case, then adjust P5 until it is. Then pins 13 and 1 of IC8 are connected to +5 V and P6 is adjusted until the output of IC9 is 1.00 V. Now pin 13 of IC8 is connected to ground and pin 2 to +5 V (as well as pin 1) and the output from IC9 should be 2.00 V. Any deviation can be corrected using P6. After this adjustment, the 1 V/octave characteristic of the QOV voltage is set. The output of IC9 should be 3.00 V when pins 3 and 13 of IC8 are connected to +5 V and pins 1, 2 and 9 ... 12 are earthed. Before inserting the EPROM, IC5 should be checked to ensure that the high order address bits are present on pins 19, 22 and 23. These should, of course, also agree with the position of S1, not forgetting to press S3 after S1 is changed each time.

Now the same adjustment must be carried out on the A/D conversion circuit. IC1 is removed from its socket and pin 6 (or the

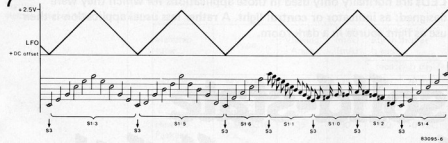

music quantizer
elektor october 1983

Figure 7. This is the component overlay for the printed circuit board, with all the components from figures 4 and 5, except for resistors R16...R24 and S1...S3.

zones	notes	number of addresses	addresses: zone 0	notes	data (hex)			
1	major chord		XX = 00		00			
	C	8	XX = 01	do - C				
	D	6	XX = 02					
	E	5	XX = 03					
	F	7	XX = 04					
	G	6	XX = 05	do# - C#				
	A	5	XX = 06					
2	pentatonic chord		XX = 07		04			
	C#	10	XX = 08	ré - D				
	D#	9	XX = 0A					
	F#	10	XX = 0B					
	G#	9	XX = 0C					
	A#	10	XX = 0D	ré# - D#				
	3	C major		XX = 0E			0C	
C		16	XX = 0F					
E		16	XX = 10					
G		16	XX = 11					
4		A minor		XX = 12	mi - E	10		
		C	16	XX = 13				
		E	16	XX = 14				
	A	16	XX = 15	fa - F				
	5	G major		XX = 16			14	
		D	16	XX = 17				
		G	16	XX = 18				
B		16	XX = 19	fa# - F#				
6		F major		XX = 1A		18		
		C	16	XX = 1B				
		F	16	XX = 1C				
	A	16	XX = 1D	sol - G				
	7	D major		XX = 1E			1C	
		F#	16	XX = 1F				
		A	16	XX = 20				
8		for the next 4 octaves, add 30hex per octave		XX = 21	sol# - G#	20		
		9			XX = 22			
					XX = 23			
					XX = 24			la - A
			XX = 25					
			XX = 26					
			XX = 27					
			XX = 28	la# - A#				
		XX = 29						
		XX = 2A						
		XX = 2B						
		XX = 2C						
		XX = 2D	si - B					
		XX = 2E						
		XX = 2F						

wiper of P3) is connected to ground. Then adjust P4 so that pins 11...18 of IC3 are logic low.

Potentiometer P3 could be adjusted by ear as a function of the control signal applied to the quantizer. The aim is to set this pot until the musical phrase generated by a VCO to which the QOV voltage is fed follows the contours of the control signal without clipping.

Having done that, the quantizer is almost ready for use. All that remains is to find a suitable supply, whether that is from the host synthesizer or a separate circuit with regulator ICs just for this purpose. The current consumption is about 120 mA at 5 V and much less at ± 12 V.

Elsewhere in this issue we have an article about an 'EPROMmer' using the main board of the Junior Computer. Need we say more about exclusive, custom-made transcoder EPROMs?!

Table 1a

		EPROM (zone 0)		D/A
Address	hex	Data	QOV	
0000	00	00000000	0 mV	}
0001	00	00000000		
0002	00	00000000		
0003	00	00000000		
0004	04	00000100		
0005	04	00000100		
0006	04	00000100		
0007	04	00000100	83 mV	}
0008	08	00000100		
0009	08	00000100		
000A	08	00000100		
000B	08	00000100		
000C	0C	00000100		
000D	0C	00000100		
000E	0C	00000100	167 mV	}
000F	0C	00000100		
0010	10	00000100		
0011	10	00000100		
0012	10	00000100		
0013	10	00000100		
0014	14	00000100		
0015	14	00000100	250 mV	}
0016	14	00000100		
0017	14	00000100		
0018	18	00000100		
0019	18	00000100		
001A	18	00000100		
001B	18	00000100		
001C	1C	00000100	333 mV	}
001D	1C	00000100		
001E	1C	00000100		
001F	1C	00000100		
0020	1C	00000100		
0021	1C	00000100		
0022	1C	00000100		

Table 1b

		EPROM (zone 1)		D/A
Address	hex	Data	QOV	
0100	00	00000000	0 mV	}
0101	00	00000000		
0102	00	00000000		
0103	00	00000000		
0104	00	00000000		
0105	00	00000000		
0106	00	00000000		
0107	00	00000000	1 tone	}
0108	00	00000000		
0109	00	00000000		
010A	00	00000000		
010B	00	00000000		
010C	00	00000000		
010D	00	00000000		
010E	10	00000000	167 mV	}
010F	10	00000000		
0110	10	00000000		
0111	10	00000000		
0112	10	00000000		
0113	10	00000000		
0114	10	00000000		
0115	10	00000000	333 mV	}
0116	14	00000000		
0117	14	00000000		
0118	14	00000000		
0119	14	00000000		
011A	14	00000000		
011B	14	00000000		
011C	14	00000000	417 mV	}
011D	14	00000000		
011E	14	00000000		
011F	14	00000000		
0120	14	00000000		
0121	14	00000000		
0122	14	00000000		

Table 1c

ADDRESSES	SCALES*
0000...00FF	chromatic scale
0100...01FF	major chord
0200...02FF	pentatonic scale
0300...03FF	major chord C-E-G
0400...04FF	minor chord A-C-E
0500...05FF	major chord G-B-D
0600...06FF	major chord F-A-C
0700...07FF	major chord D-F-A

* every scale covers 5 octaves

Table 1a. This is an extract from the contents of zone 0 of the EPROM. All the degrees of the chromatic scale are present and the addressing is equally divided among them (4 addresses per note). Obviously, the probability of occurrence of each of the twelve notes is the same.

Table 1b. This is part of the contents of zone 1 of the EPROM. Only the seven degrees of the major scale are present. The addressing is not divided equally among them as some notes have more 'musical weight' than others. This means that some notes occur more often and last longer than others.

Table 1c. The eight zones of the EPROM with the scales and chords obtained in each of them. No matter how many notes per octave are present, the range of QOV produced by each zone is five octaves.

LEDs are normally only used in those applications for which they were designed: as indicator or control light. A rather less usual application is their use as light source in a dark room.

solid-state dark room lighting

LEDs
as light source

Using one or more LEDs for dark room lighting is not as odd as may appear at first sight. Particularly not when you consider the advantages over conventional lighting.

- Because of the well-defined spectral colours of LEDs, filters are not necessary.
- LEDs are usable when work is carried out on black and white paper, multi-grade paper, colour negative paper, and orthochromatic materials.
- The life of LEDs is not shortened by continuous on/off switching.
- LEDs do not produce heat.
- LEDs do not radiate infra-red rays.

Of course, a standard LED does not give as much light as a conventional lamp, but this problem could be overcome by the use of more than one LED. This article describes dark room lighting with LEDs which give many times more light than standard LEDs, so that you don't need to hang whole arrays of LEDs from the wall. If required, the viewing angle can be increased by placing the LEDs further apart. Furthermore, a length of transparent, corrugated perspex may be placed in front of the LEDs. To ensure that different types of paper can be processed (each type of paper is sensitive

to different colours), the circuit is divided into three parts. Each part has a different colour LED so that three colours are catered for: red, green, yellow.

The circuit

As shown in figure 1, the circuit is quite simple, making a compact construction easy to attain. The different colour LEDs are each connected to an adjustable voltage supply. The required light intensity can be set between low and maximum with presets P1, P2 and P3 respectively. At nominal intensity each LED draws a current of 20 mA, so that the total current consumption is about 120 mA maximum. Bear in mind, however, that the maximum LED current should not be exceeded: as shown in table 1, the maximum current for some LEDs is only 35 mA. When such LEDs are used, resistors R2...R7 should be 220 Ω . It is, of course, not necessary to build all three stages: according to requirement and personal preference, one or two stages may be sufficient. On the other hand, the number of stages may be more than three. In these cases only the value of R1 needs to be modified to the new layout: if only one

Figure 1. The circuit diagram shows that the dark room lighting can be built in almost no time at all.

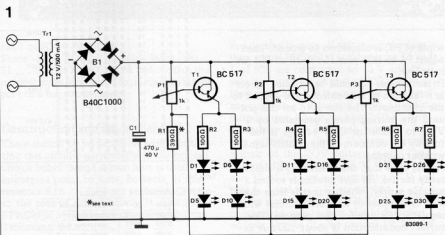

D1 ... D10 = MV 5752; HLMP 3316; HLMP 3750 (red)
D11 ... D20 = MV 5352; HLMP 3416; HLMP 3850 (yellow)
D21 ... D30 = MV 5252; HLMP 3519; HLMP 3950 (green)

Table 1

Manufacturer	Type	Viewing Angle	LED (max) (mA)	Luminous Intensity in mcd at		Wavelength (nm)		
				LED	LED	red	yellow	green
General Instruments	MV 5252	28°	35	15	20 mA			565
- do -	MV 5352	28°	35	45	20 mA		585	
- do -	MV 5752	28°	35	40	20 mA	635		
Hewlett-Packard	HLMP 3316	35°	90	30	10 mA	626		
- do -	HLMP 3416	35°	60	30	10 mA		585	
- do -	HLMP 3519	24°	90	50	20 mA			569
- do -	HLMP 3750	24°	90	125	20 mA	635		
- do -	HLMP 3850	24°	60	140	20 mA		583	
- do -	HLMP 3950	24°	90	120	20 mA			565
Stanley	H 500	10°	300	500	20 mA	660		
- do -	H2K		300	2000	20 mA	660		

This table shows various types of LED which meet the requirements laid down in this article.

stage is required, R1 should be 1.2 k Ω ; with two stages, 680 Ω . As mentioned earlier, the LEDs must have a high light output: table 1 gives a number of suitable types. Other high-efficiency types may, of course, be used provided that their spectral colours are in line with requirements.

Selecting the right colour LED

The type of paper being processed is the determining factor when selecting the correct LEDs. Generally, there is a 'safe' colour for each type of photographic paper to which the paper is not sensitive and this is the only colour light you should use during processing.

Normal black and white paper

When this type of paper is being processed, all three colours may be used simultaneously. None the less, some care is advisable with the colour green as the wavelength of this colour lies close to the

sensitivity curve of this paper (see figure 2). Light intensity is not critical for this paper so that the dark room lighting may be adjusted to maximum. The minimum distance between paper and lighting must be determined by trial and error.

Multi-grade paper

Multi-grade paper is processed in layers which are particularly sensitive to the colours blue and green. Only red and yellow LEDs should therefore be used in this case. None the less, if you use the 'prohibited' green LED interesting effects are obtained.

Colour negative paper

Because of the special composition and high sensitivity of this paper, use only the yellow LEDs with reduced light output. Better still, use indirect diffused light by pointing the light source at maximum intensity towards the wall or ceiling. If these are dark, use a sheet of white paper as a reflector.

Colour reversal paper

As this type of paper is sensitive to all colours, it can only be processed in total darkness.

Orthochromatic material

When working with these materials, use only red LEDs. Intensity is best determined by means of test strips. Such strips should really be used with the other types of paper as well to determine for how long, at what minimum distance, and at what intensity the LED lighting can be used. The graphs in figure 2 should prove useful for this purpose, although they are, of course, well-known to experienced photographers. M

Figure 2. The sensitivity graphs of various types of photographic paper are given in dotted lines. The graphs in solid lines show the operating wavelengths of the different colour LEDs.

2

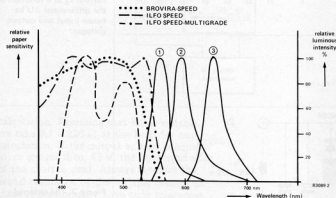

No, this article does not deal with a regulator for 10,000+ volts, but for all that, 125 V is 'high' voltage when it concerns an integrated circuit. The type TL 783 IC does not only give an output of 125 V (maximum), but also allows a differential between its input and output voltages of 125 V. That is more than three times the usual 40 volts!

high-voltage regulator

An integrated, presettable voltage regulator with only three connections is not likely to hit the headlines these days. The news about the TL 783 is that it tolerates a voltage differential between its input and output of 125 V, and is capable of delivering an output of 125 V (maximum). On top of that, it equals or exceeds the parameters, with the exception of output current, of 'improved' types like the LMX 17, LM 117, LM 217, and LM 317. The high voltage differential is made possible by the use of a DMOS (double-diffusion metal oxide semiconductor) output transistor. At the same time, this transistor limits the maximum output current of the circuit to 700 mA. Figure 1 shows the correlation between output current and voltage differential.

The TL 783 contains a protection circuit consisting of a current and a temperature limiter. The temperature limiter switches the output off as soon as the chip temperature reaches 165°C, and automatically switches it on again when the temperature drops below 165°C. Current limiter is, strictly speaking, a misnomer, as this stage is really a load limiter: it prevents the IC dissipating more than 20 W.

Figure 2 shows a typical circuit using a

TL 783: the function of D1 and D2, as well as that of C1 . . . C4, is virtually the same as if a LMX 17 were used. Briefly, C1 is not to be confused with a smoothing capacitor (not shown) which follows the rectifier. It is necessary to prevent voltage peaks and

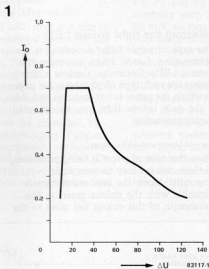

Figure 1. Maximum output current I_O as a function of the differential ΔU between input and output voltages.

2

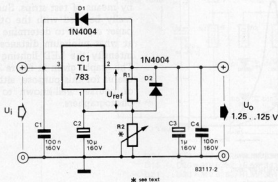

Figure 2. The external circuit diagram of the TL 783 voltage regulator. Values of R1 and R2 for a given output voltage are calculated according to the chart in figure 3.

other noise from reaching the regulator, there by reducing the possibility of this device to oscillate. Use is thereby made of the property of capacitors to act as frequency-dependent resistors, and of the characteristics of metallized polystyrene or polyester capacitors at high frequencies. Capacitor C4 serves virtually the same function at the output as C1 at the input. Capacitor C2 suppresses any ripple present on the input to the IC; for a value of 10 μF , the suppression is not less than 80 dB across the total range of output voltages. Capacitor C3 is the usual smoothing electrolytic at the output. The two diodes are necessary because of the capacitors: when the circuit is switched off, polarity reversal may take place owing to the slow discharge of the capacitors and this could cause damage to parts of the IC. The diodes prevent this by short-circuiting the voltages.

Figure 3 shows a chart for the computation of R1 and R2. Both these resistors should not be less than 0.25 W. Starting point of the chart is the maximum output voltage, U_{Omax} . If U_O is smaller than 43 V, the left-hand side of the chart is used for the

Table 1. Examples of the use of figure 3.

R2 variable

U_{Omax}	R1	R2
100 V	595 Ω (560 + 33)	47 k Ω
75 V	373 Ω (270 + 100)	22 k Ω
50 V	256 Ω (220 + 33)	10 k Ω

R2 fixed

U_{Omax}	R1	R2
100 V	493 Ω (470 + 22)	39 k Ω
75 V	369 Ω (330 + 39)	21.76 k Ω (15k + 6k8)
50 V	244 Ω (220 + 22)	9.506 k Ω (6k8 + 2k7)
24 V	220 Ω	4.004 k Ω (2k2 + 1k8)
12 V	220 Ω	1892 Ω (1k5 + 390)
5 V	220 Ω	660 Ω (330 + 330)

high-voltage regulator
elektor oktober 1983

3

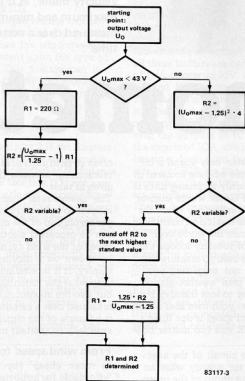

83117-3

Table 1. Some values of R1 and R2 calculated with the aid of figure 3 for various values of required output voltages.

calculation. Assuming that R2 is variable, we take $R1 = 220 \Omega$ as the basis for our calculation. If the output voltage is equal to, or greater than, 43 V, the right-hand side of the chart is used. Always measure the actual resistance of the variable resistor as these types normally have wide tolerances. Table 1 shows some typical values for the resistances at various output voltages.

4

TL 783



83117-4

Figure 4. Pin connections of the TL 783.

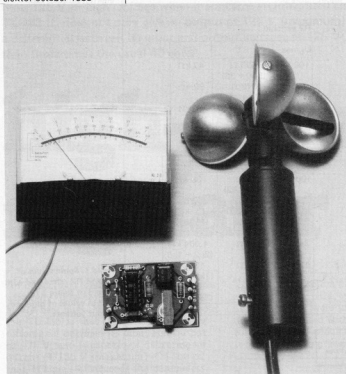

Not even meteorology is safe from electronics any more, it seems. While it is true that the rotating mechanical element is still an essential part of this 'instrument', the bulk of the work is now done by electronic components. The anemometer described here is more than an instantaneous wind velocity meter, as it also stores the maximum and minimum values measured over a certain period of time.

anemometer

wind speed
on a
moving-coil
meter

The word 'anemometer' may sound a bit unusual to most people who are involved in electronics. This is hardly surprising since it comes from two old Greek words *anemos* (wind) and *meter* (to measure). When the two are combined, the result is an instrument familiar to weather men the world over. It contains a number of rotating scoops that catch the wind and is used to measure the wind speed. We are not suggesting you should set up your own weather station (that is one quick way to lose friends), but it is certainly nice to get your own idea of the weather, and the wind speed is one thing a barometer cannot tell you (no matter how hard you 'tap' it!).

Before we get to the circuit of the anemometer, let us first see exactly what an anemometer is. As the photo of the prototype at the heading of this article clearly shows, it consists of a rotating (wind)mill mounted in a holder. The actual mill consists of three or four hemispheres, or something similar, which turn when caught by the wind. The speed of rotation depends, of course, on the speed of the wind. Wind speed is generally stated according to the Beaufort scale. This is a system devised in 1808 by Sir Francis Beaufort, an English admiral, to relate the strength of the wind with the advisability of going to sea. He defined a twelve-way scale ranging from calm to hurricane force. Nowadays wind speed is

often given in units of m/s or in knots and the relationship between the various scales is given in table 1.

The anemometer described here uses a magnet to open and close a reed switch once per revolution of the mill. This information can be processed electronically so that the speed of the wind causing this rotation can be shown on a moving coil meter or a display. It is interesting to be able to see not only what the instantaneous wind speed is, but also the maximum and minimum values measured over a certain period of time. This is a feature of the circuit that should appeal especially to amateur meteorologists.

From wind speed to analogue voltage

In most 'cheap' (by which we mean 'affordable for hobbyists') anemometers, the revolutions of the mill are converted into a number of pulses. That can, for example, be done with a reed switch and a magnet. The magnet is fixed to the axle of the mill and the reed switch is mounted firmly in the case of the anemometer. Once every revolution the magnet comes close to the reed switch and this causes the contact to close. The number of times the switch closes is therefore equal to the number of revolutions of the mill per second. In other words, the number of pulses per second given by the reed switch is directly proportional to the wind speed.

It would be much easier to work with an analogue voltage instead of a frequency for further processing of the signal. Therefore the pulse frequency of the reed switch is first converted to a voltage with a small converter circuit. This is the circuit shown in figure 1. The reed switch of the anemometer is connected between ground and the inputs of schmitt triggers N1...N3. Resistor R1 ensures that the inputs of these gates are '1' when the reed switch is open. Zener diode D1 protects the inputs against noise that could be set up at the sensor or in long leads. Together with P1, R2 and C1, N1...N3 make up a monostable multivibrator. At every rising edge of schmitt triggers N1...N3 a logic zero is present at the inputs of N4...N6. Because of the time constant $C1/R2 + P1$ it takes a certain time before N4...N6 reach their upper triggering threshold. The pulse output from these gates always lasts the same length of time and this pulse is produced every time the reed switch opens. Three schmitt triggers in parallel are used here to ensure that enough output current is produced. The pulse output from N4...N6 is subsequently converted to an analogue voltage by means of integrator R3/C2, and this voltage is buffered by IC2.

The level of the analogue voltage can be adjusted using P1 so that the circuit gives, for example, 1 V when the wind speed is 30 m/s (this is dependent upon the type of anemometer used). This voltage can in principle be applied directly to a moving coil meter (1 V full scale deflection) or a digital meter.

The memory section

The circuit shown in figure 2 is the diagram of the memory section of the anemometer. It may seem a bit complicated at first glance but this is due to the fact that it is not easy to store an analogue value in memory for a long period of time. In this case, the analogue value is first converted to its digital equivalent which is stored in a counter. To find the maximum and minimum values, the instantaneous wind speed must constantly be compared with the previous maximum and minimum values stored in memory. For this comparison the digital value is first converted to analogue form by means of a D/A converter. The 'memories' for the maximum and

Table 1.

Beaufort scale	Description	Wind speed		
		m/s	mph	knots
0	calm	0.0 ... 0.2	0 ... 1	0 ... 1
1	light air	0.3 ... 1.5	1 ... 3	1 ... 3
2	light breeze	1.6 ... 3.3	4 ... 7	4 ... 6
3	gentle breeze	3.4 ... 5.4	8 ... 12	7 ... 10
4	moderate breeze	5.5 ... 7.9	13 ... 18	11 ... 16
5	fresh breeze	8.0 ... 10.7	19 ... 24	17 ... 21
6	strong breeze	10.8 ... 13.8	25 ... 31	22 ... 27
7	moderate gale	13.9 ... 17.1	32 ... 38	28 ... 33
8	fresh gale	17.2 ... 20.7	39 ... 46	34 ... 40
9	strong gale	20.8 ... 24.4	47 ... 54	41 ... 47
10	whole gale	24.5 ... 28.4	55 ... 63	48 ... 55
11	storm	28.5 ... 32.6	64 ... 75	56 ... 65
12	hurricane	32.6 +	75 +	65 +

anemometer
elektor october 1983

minimum values of wind speed are IC7 and IC8. These are dual four-bit binary counters, which can be reset by pressing push button S2. The clock input of each counter is provided by a square-wave generator (N1 for IC7 and N2 for IC8) supplying a frequency of about 200 Hz. Each generator can be switched on or off via opamps A2 and A4. Diodes D1 and D2 and resistors R9 and R10 protect the inputs of N1 and N2 from negative voltages (as the opamps have a symmetrical supply). The outputs of IC7 are connected to three-state buffers, whereas IC8 uses the inverting type. The outputs of all these buffers are connected to the inputs of D/A converter IC9. The oscillator around N3 and N4 (whose frequency is about 100 Hz) defines which of the two counters is connected to the inputs of the D/A converter. If the output of N3 becomes logic zero the outputs of IC7 are connected to the inputs of IC9, and if the output of N4 becomes logic zero the inverted output signals of IC8 are connected to the D/A converter. The buffers of the unused counter are switched to high impedance. The D/A converter gives an output of between 0 and 1 V, depending on the digital input signal it receives. This analogue voltage is available at the output of opamp A5. The maximum output voltage can be set with potentiometer P2. The comparator section is built up around ES1, ES2 and A1...A4. The two electronic switches are driven by ES3 and T1. These latter two are needed to adapt the output signal from oscillator N3/N4 to the sym-

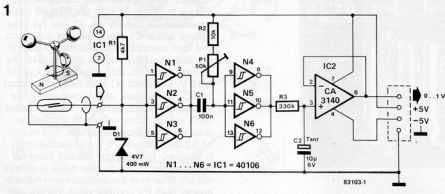

Figure 1. The measuring section which converts the pulses generated by the wind mill into an analogue voltage. The circuit consists of a monostable multivibrator followed by an integrator and buffer.

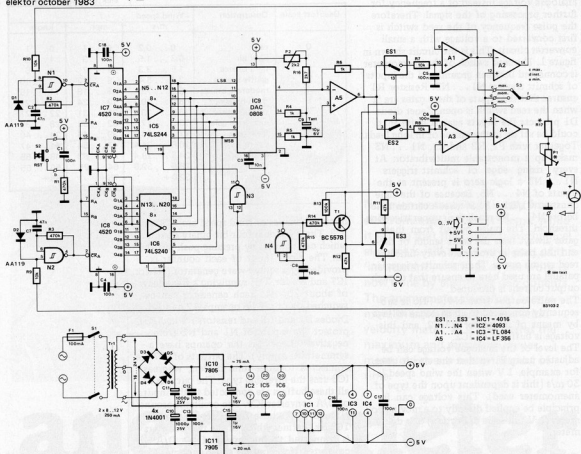

Figure 2. The memory section. Counters IC7 and IC8 store the maximum and minimum values of the wind speed respectively. The contents of the counters are continuously compared with the instantaneous wind speed by the D/A converter and the circuitry around A1...A4. Whenever it is necessary, the counters are adjusted to the new situation.

3

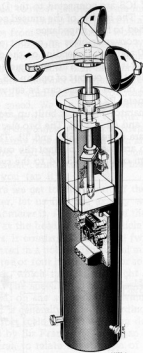

Figure 3. This is an example of how a wind mill for the anemometer can be made.

metrical supply voltage used in the comparator section. At the moment IC7 is connected to IC9, ES1 is simultaneously closed. Capacitor C5 is then charged to the voltage supplied by A5. Opamp A1 serves as a buffer for this capacitor and the voltage across C5 is compared with the instantaneous 'wind voltage' via A2. In the other case (IC8 connected to IC9) ES2 is closed. Now C6 is charged and the output of buffer A3 is compared with the instantaneous wind voltage via A4.

The output signal from the converter circuit goes to A2, A4 and switch S3. If S3 is in mid position the meter indicates the instantaneous wind speed. The corresponding voltage is compared with the voltages across capacitors C5 and C6 via A2 and A4. The voltage across C5 represents the maximum and that across C6 the minimum value. If the instantaneous value is greater than the voltage across C5, the output voltage of A2 is +5 V. Oscillator N1 then causes the count on IC7 to increase, and consequently the voltage across C5 increases. This continues until the capacitor voltage is just greater than the instantaneous voltage. The output of A2 then falls to -5 V and oscillator N1 is blocked. Because the counter can only count upwards, the highest value is always stored. Whenever the instantaneous value is greater than the counter value, the counter

is adjusted to the new value.

The minimum value is stored in much the same way. In this case the voltage across C6 is compared with the instantaneous value. Now, however, the output of A4 is +5 V if the instantaneous voltage is lower than the capacitor voltage. Then N2 oscillates and IC8 counts up. Because N13...N20 are inverters, the output voltage of the D/A converter is actually lower, so that the voltage across C6 decreases. This means that the voltage across C6 drops as the content of the counter increases. Whenever the instantaneous voltage is lower than the minimum value in the counter, the counter is adjusted accordingly.

The reason for continually switching between the two counters is to avoid the need for a second D/A converter, as these are not cheap.

The 'memories' are reset to zero by pressing push button S2. In this way the maximum and minimum values can be read from the meter, by switching S3, once a day, for example, and the circuit can then be reset ready for the next day. The values of R17

**Parts list,
memory board**

Resistors:

- R1...R4, R14,
- R15 = 470 k
- R4, R5 = 1 k
- R6 = 1 k 1%
- R7...R10 = 10 k
- R11, R12 = 47 k
- R13 = 100 k
- R16 = 2k7
- R17 = see text
- P1 = see text
- P2 = 2k2 ten turn preset

Capacitors:

- C1, C4...C6, C8, C12, C13,
- C16...C18 = 100 n
- C2, C7 = 47 n
- C3 = 10 n
- C9 = 10 μ /6 V tantalum
- C10, C11 = 1000 μ /25 V
- C14, C15 = 1 μ /16 V

Semiconductors:

- D1, D2 = AA 119
- D3...D6 = 1N4001
- T1 = BC557B
- IC1 = 4016
- IC2 = 4093
- IC3 = TL 084
- IC4 = LF 356
- IC5 = 74LS244
- IC6 = 74LS240
- IC7, IC8 = 4520
- IC9 = DAC0808
- (Technomatic)
- IC10 = 7805
- IC11 = 7905

Miscellaneous:

- S1 = double pole mains switch
- S2 = single make push button
- S3 = single pole, 3-way rotary switch
- F1 = 100 mA slow blow fuse
- Tr1 = 2 x 8...10 V/250 mA transformer

anemometer
elektor oktober 1983

Figure 4. The printed circuit board shown here contains the memory circuit and the power supply for the whole circuit.

4

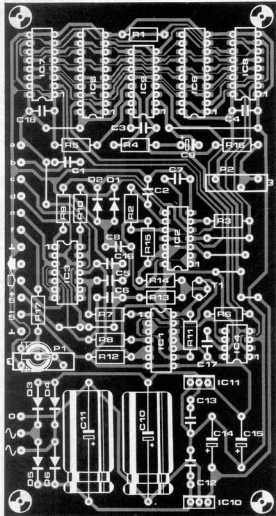
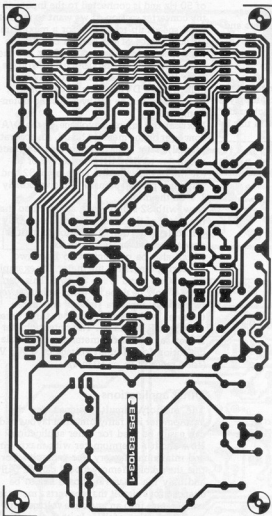

Parts list, measuring board

Resistors:

R1 = 4k7
R2 = 10 k
R3 = 330 k
P1 = 50 k preset.

Capacitors:

C1 = 100 n
C2 = 10 μ /6 V tantalum

Semiconductors:

D1 = 4V7/400 mW
zener diode
IC1 = 40106
IC2 = CA 3140

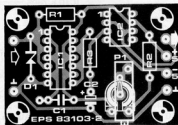
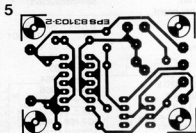

Figure 5. The printed circuit board layout for the measuring/converter board.

and P1 depend on the sensitivity of the moving coil meter used; for a 100 μ A meter R17 is 6k8 and P1 is 5 k.

The power supply is straightforward. It simply contains two voltage stabilizers and a few other components to give a symmetrical supply of ± 5 V.

The anemometer

Various manufacturers supply anemometers, but they are generally reluctant to supply the mechanical part without the electronics. These are not cheap in any case. With this in

mind we set out to see whether we could build the mechanical part of the anemometer ourselves. The design we came up with is shown in figure 5. This sort of 'd.i.y. windmill' has the disadvantage that it is not calibrated so that it is not possible to get an accurate reading of the wind speed. However, it could be improved by comparing it with a 'real' anemometer, but that comes very close to being another 'catch 22'! The only comment about mounting the windmill is that it should be located where it will not be affected by 'false' winds. Calibrating the mounting stand should not be any problem.

Constructing the electronics

The measuring/converter and memory sections of the anemometer can be built on the printed circuit boards shown in figures 4 and 5. After assembling the boards, the whole circuit, complete with switches, transformer, meter and so on, can be placed in a suitable case. The scale for the meter is shown in figure 6.

The converter section must now be adjusted. To do this, the auxiliary circuit shown in figure 6 is needed. This produces a frequency of 50 Hz and is connected to the input of the converter section. If we want to measure wind speeds up to 30 m/s for a maximum output voltage of the section of 1 V, the wind speed corresponding to 50 Hz and the corresponding theoretical output voltage from IC2 can be calculated for any windmill. Using a DVM at the output of IC2, this voltage can be set by adjusting potentiometer P1.

Next set the reference voltage of the D/A converter on the memory board. An accurate (digital) meter is needed here also. Connect the meter to the MIN connection of S3 (or the output of A3). Then press S2 and while it is pressed adjust P2 to give exactly 1 V on the meter.

Now, with S2 still pressed, adjust P1 so that the meter of the anemometer gives exactly full scale deflection. The whole circuit is now calibrated and ready for use.

It can also be convenient to have two measuring ranges for the meter, for example, 0... 10 m/s and 0... 30 m/s. This can quite simply be done by using a changeover switch and an extra resistor and potentiometer, with resistances about three times as large as R17 and P1. The potentiometer is then set so that the meter gives full scale deflection for an input voltage of 0.333 V (for a range of 0... 10 m/s).

Other applications

The memory circuit designed for this anemometer is a fairly universal layout and can easily be used for other applications. How about a thermometer with maximum and minimum memory, for example? For this the whole memory board can be built and only the measuring board has to be changed for a circuit that converts a measured temperature into an analogue voltage with a maximum value of 1 V. In that case, the meter has of course to be given a temperature scale.

Figure 6. This is a scale which could be used for the meter.

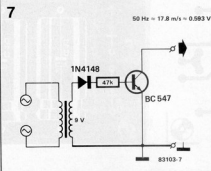
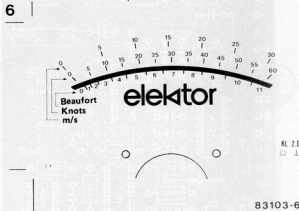

Figure 7. This is a calibration circuit giving a frequency of 50 Hz to adjust the measuring section.

PC board pages

The following pages contain the mirror images of the track layout of the printed circuit boards (excluding double-plated ones as these are very tricky to make at home) relating to projects featured in this issue to enable you to etch your own boards.

- To do this, you require: an aerosol of 'ISODraft' transparentizer (available from your local drawing office suppliers; distributors for the UK: Cannon & Wrin), an ultraviolet lamp, etching sodium, ferric chloride, positive photo-sensitive board material (which can be either bought or home made by applying a film of photo-copying lacquer to normal board material).
- Wet the photo-sensitive (track) side of the board thoroughly with the transparent spray.
- Lay the layout cut from the relevant page of this magazine with its printed side onto the wet board. Remove any air bubbles by carefully 'ironing' the cut-out with some tissue paper.
- The whole can now be exposed to ultra-violet light. Use a glass plate for holding the layout in place only for long exposure times, as normally the spray ensures that the paper sticks to the board. Bear in mind that normal plate glass (but not crystal glass or perspex) absorbs some of the ultra-violet light so that the exposure time has to be increased slightly.
- The exposure time is dependent upon the ultra-violet lamp used, the distance of the lamp from the board, and the photo-sensitive board. If you use a 300 watt

UV lamp at a distance of about 40 cm from the board and a sheet of perspex, an exposure time of 4...8 minutes should normally be sufficient.

- After exposure, remove the layout sheet (which can be used again), and rinse the board thoroughly under running water.
- After the photo-sensitive film has been developed in sodium lye (about 9 grammes of etching sodium to one litre of water), the board can be etched in ferric chloride (500 grammes of Fe_3Cl_{12} to one litre of water). Then rinse the board (and your hands!) thoroughly under running water.
- Remove the photo-sensitive film from the copper tracks with wire wool and drill the holes.

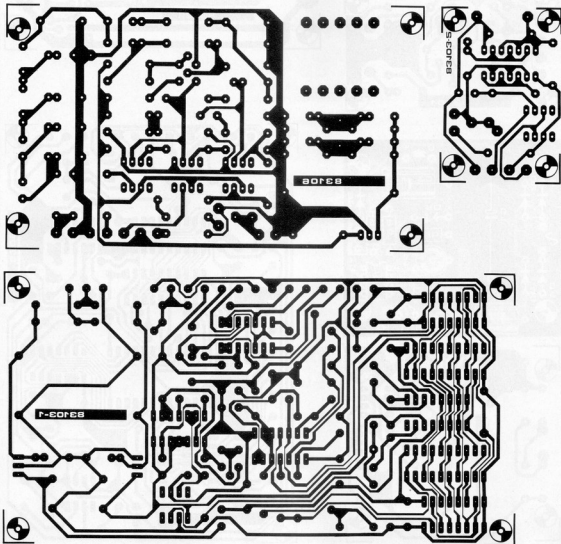

missing link

Parallel-serial keyboard converter (May 1983, page 5-50)

If this circuit is used with the ASCII keyboard also published in May 1983 the value of C5 can be critical. It is given as 220 n in the parts list but

- for 1200 baud C5 = 47 n is better
- between 200 and 900 baud C5 = 120 n is suitable.

Acoustic telephone modem (February 1983, page 2-42)

The formulae on page 2-50 may be misleading as no units have been stated. In formulae a and b R is in $k\Omega$ and C in μF , but for all other formulae R is in Ω and C in F. In all cases f_1 and f_h are in Hz.

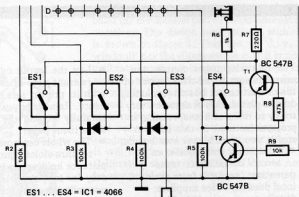

Morse decoding with the Z80A (May 1983, page 5-60)

We have discovered that two lines in the hex dump listing for this article were interchanged. The data on line 200 should be on line 220, and the contents of line 220 should be on line 200.

Low cost CMOS lock
 (Summer circuits 1983,
 page 7-75)

PC board pages

Unfortunately some Summer gremlins crept into this circuit, removing components and changing values, so that the lock will open when the first number of the combination is pressed. To correct this two diodes and one resistor must be added, and the value of R7 must be changed to 220 Ω. The correct layout, minus gremlins, is shown in the diagram here.

200:	00	00	00	00	00	00	00	00	00	00	00	00	00	00	00
210:	00	00	00	00	00	00	00	00	00	00	00	00	00	00	00
220:	41	42	43	44	45	46	47	48	49	4A	4B	4C	4D	4E	4F
230:	51	52	53	54	55	56	57	58	59	5A	5B	5C	5D	5E	5F
240:	36	37	38	39	2E	2C	3A	3F	27	2D	2F	2D	2D	55	41
250:	4F	4B	FF												

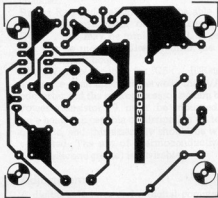
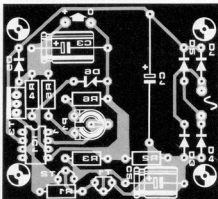
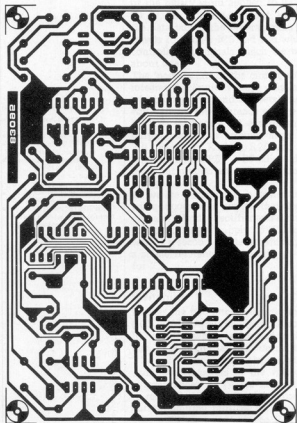
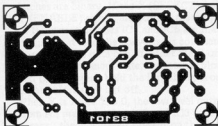
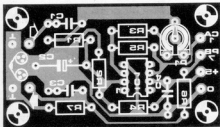
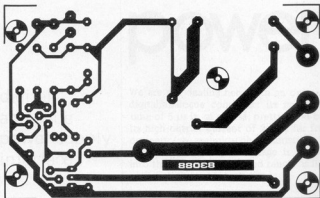

E. Stöhr

digital/
analogue
power supply
interface

Many integrated circuits are now so familiar to most of us that we tend to overlook some of their remarkable characteristics. Here we take a well-known voltage regulator, the 723, and hook up a digital/analogue converter to its input and the result is that we can program the output voltage very precisely and can also select the maximum output current (with a digital command, no less!). This circuit should interest anybody who wants to use the 'digital' accuracy of a microprocessor system to meet stringent analogue requirements.

programmable power supply

We are not dealing here with an ordinary digital/analogue converter: its conversion time of 5 μ s is, of course, pretty good but its high output current of 2 A is far from ordinary (see technical characteristics). The programmable output voltage is divided into three digitally switched ranges as is the case with the output current.

Circuit description

The heart of the circuit is the 8-bit digital/analogue converter, IC1. The output of this IC, E_O , supplies a high impedance analogue signal which is proportional to the value of the binary word applied to its inputs B1...B8. This binary word, supplied via the data bus of the programming system, travels to latches IC5 and IC6 which are controlled by signals which we will talk about later.

The 'power part' of the circuit consists of integrated circuit voltage regulator IC3 which compares (and corrects) the output voltage with the reference voltage supplied by IC2. Darlington T9 ensures that the output current is usefully large: about 2 A. Resistors R18...R20 and preset potentiometers P3...P5 adjust the maximum output current and maximum output voltage.

As we are dealing with a power supply, it will not come as a surprise that the circuit contains a bridge rectifier and a smoothing capacitor for the supply of IC3 and T9 as well as a second regulator which provides a stable reference voltage ($U_{ref} = 10.0$ V) for IC1.

Switching

Besides the two latches already mentioned (IC5, IC6), there is an identical second pair, IC7 and IC8 which is also tied to the data bus. These latter latches control transistors T1...T8 which switch the various resistors and potentiometers in the voltage and current ranges. As T4 and T5 are connected to relays Re4 and Re5 (which connect the current-limiting resistors in parallel), and T1...T3 are connected to Re1...Re3

(which switch the voltage ranges), there are three unused outputs left which may be used for additional low power relays.

The control signals for the two sets of latches are binary. If the X (SELECT) and Y (ENABLE) signals are both 1, the output of N1 is zero; latches IC5 and IC6 are then 'transparent' and the converter is connected directly to the data bus. If either the X or the Y signal changes state, the latches block and their outputs hold the last binary word input before they cut off.

When X is 1 and Y is 0, the low level output from N3 makes latches IC7 and IC8 'transparent': the logic levels present on the data bus are then transferred directly to the bases of switching transistors T1...T8. If neither of the situations outlined above pertains, the circuit is completely isolated from the system controlling it.

Summarising, in the first situation mentioned, the microprocessor controls the output voltage, while in the second situation, the voltage and current ranges are switched.

Construction

Depending on the programming system used, the circuit described may have to be changed to meet individual requirements. The bus configuration, the voltages corresponding to the different logic levels and the address decoding needed to obtain signals X and Y are the elements which may have to be changed.

Relays Re4 and Re5 must each be able to handle the maximum output current; Re1...Re3 may be miniature DIL types and can be mounted directly onto the printed circuit board.

The 5 V supply section for IC5...IC8 can also serve as an interface between the D/A converter and the microprocessor system bus. Power transistor T9 must be mounted on a heat sink capable of dissipating up to 60 watts, and this assembly should be well ventilated. The use of thermoconductive paste (silicone grease) is advisable.

Adjustment

A digital voltmeter and a digital command

technical characteristics

- input voltage: 5 V DC (TTL); 12 V DC (ICMOS)
- resolution: 8 bits
- output voltage: 0...30 V programmable in three ranges
- programmable ranges:
 - 0...5 V (1 bit = 19.5 mV)
 - 0...13 V (1 bit = 90 mV)
 - 0...30 V (1 bit = 117 mV)
- switchable output current: 2 A; 0.5 A; 50 mA
- drive: via signals SELECT and ENABLE (these can be obtained by address decoding)

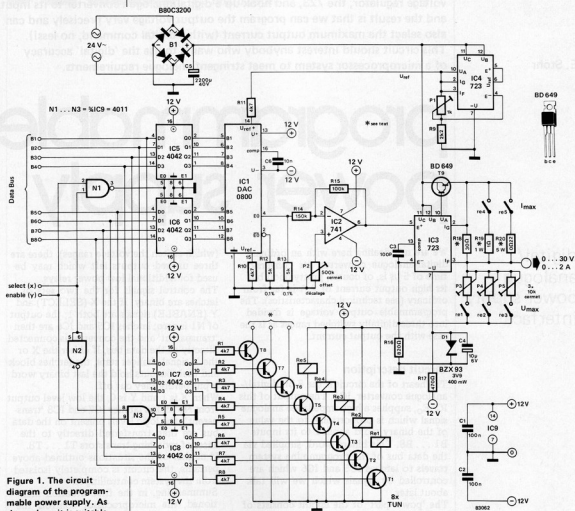

Figure 1. The circuit diagram of the programmable power supply. As shown here it is suitable for CMOS input levels but can be made TTL compatible by changing the supply voltage to IC5 ... IC8 to 5 V.

decoding

X	Y	Function
1	1	D/A conversion
1	0	range switching
0	1	—
0	0	—

The signals for X and Y are obtained by using a suitable combination of address lines of whatever computer is used.

system (preferably a microprocessor) to program the voltage supply are required for adjusting the circuit.

First, apply eight logic 0 levels to inputs B1 ... B8 and a logic 1 to the SELECT (X) and ENABLE (Y) lines. Adjust P1 such that the output voltage (U_{ref}) from IC4 is exactly 10.000 V on the digital voltmeter. Next, set the ENABLE (Y) line to logic 0 and data lines B4 and B8 to 1. Relays Re1 and Re5 should make. Reset the ENABLE line to 1 and all data lines B1 ... B8 to 0. The output voltage (U_{output}) should be zero volts. If not, adjust P2 to compensate for the offset. Set all lines B1 ... B8 to logic 1 and adjust U_{output} with P3 until it is 5.000 V. Check the output current which should be about 2 A. Then, set B5 and B7 to logic 1 and all other B lines and the ENABLE line to 0; relays Re2 and Re4 should now make. Reset the ENABLE and B1 ... B8 lines to 1 and

adjust U_{output} to 13.000 V with P4; the output current should now be about 500 mA.

Finally, set line B6 to logic 1, and all other B lines to 0. When a logic 0 is applied to the ENABLE line, and this line and the B1 ... B8 lines are immediately reset to 1, relay Re3 makes and Re4 breaks. Adjust the output voltage to 30.000 V with P5; the output current should not exceed 50 mA. The programmable power supply is now ready for use. It will be very useful in applications requiring great precision and flexibility. All that remains is to write the necessary software to control this power interface: a small computer system such as the Elektor Junior Computer is eminently suitable. If you have written any interesting programs for using this interface and you think others might benefit from them, we should be pleased to hear from you.

Elsewhere in this issue we described the theory behind Basicode-2 so it is only natural that we should show how the Junior Computer can use it. Here we give the Basicode software and everything else that is necessary to allow the Junior Computer to use Basicode-2. This means that the Junior Computer can now easily exchange BASIC programs stored on cassette tape with other computers. Moreover, 'received' programs can run directly on the JC, so that BASIC in combination with Basicode is a universal, completely exchangeable computer language.

basicode-2

interface for the Junior Computer

As we have already described all the various facets of Basicode, we will simply begin here by talking about the Junior with Basicode. The Basicode translation programs for the expanded Junior and the DOS Junior are not the same as they use different BASICs and handle their memory in different ways. To use Basicode, either an expanded Junior with KB-9-BASIC and Elekterminal or a DOS Junior and Elekterminal are needed.

The translation programs

The translation programs for both Junior versions are written in machine code. The complete source listing is given in table 1, complete with explanatory text. This is for the expanded Junior with KB-9-BASIC. The source listing for the DOS Junior is not given as it is almost the same as this listing, only a few of the addresses are different. The hexdumps are shown in table 2 (Junior with KB-9-BASIC) and table 3 (DOS Junior).

In the expanded Junior with KB-9-BASIC the translation program is at addresses \$0200...\$059B, and in the DOS Junior it is at \$E000...\$E39B. These ranges are selected because there is generally RAM there, and the programs really have to be in RAM to work properly (so they cannot be placed in an EPROM). Once the program is typed in, it can simply be written to a cassette or floppy disk, so that the next time it is to be used it can easily be read in. The program consists of a write and a read section. We will concentrate on the expanded Junior in order to describe how the program is used, but at any point where the DOS Junior differs, this is indicated by the comments in brackets.

Reading

First the Basicode translation program is typed in (or read in, if it is already stored on cassette). Both read and write programs can be stored in one file on cassette: SA = 0200, EA = 059C (DOS Junior: SA = E000, EA =

E39C). Next the KB-9-BASIC is read in from cassette (see Elektor April 1982), or from a floppy in the case of the DOS Junior. Then the BASIC can be started in the usual way. At this stage a Basicode program can be loaded. This requires the small interface described at the end of this article. A program is loaded as follows:

First type NEW to erase any old programs. Then type:
POKE 8256,0 : POKE 8257,4 : X =USR(X)
(POKE 574,0 : POKE 575,226 : X =
USR(X))

followed by a (carriage) return.

The sign \equiv now appears on the hex display of the Junior and indicates that there is no synchronization. The cassette recorder can then be started. If the program receives any signals the \equiv sign jumps back and forth on the two right-hand displays. If the 2400 Hz header is now received, a slowly jumping sign appears on the right-hand displays. This shows that the program is working on synchronizing. This jumping display lasts about 2 seconds, then the sign is stationary on both displays for the rest of the leader. At the end of the leader when the actual program begins, both displays show //, and as long as the data is properly received this sign lights evenly on both displays. When the complete program is received, the computer automatically gives a listing of it on the screen or printer. After doing this, the computer gives an 'OK'.

If an error has appeared while reading in the program, the message 'CHECKSUM ERROR' is given after the listing. In this case the program must be checked or it could be read in again in the hope of a better result. On no account must the listing be interrupted by pressing a key. If this is done, there is a chance that both BASIC and Basicode programs will have to be read again (or retyped!). Even if faults are seen in the listing, such as lines being written over one another (that can happen if there is sudden interference on the tape), you must still wait until the

Junior
communicates
with other
computers

Table 1

0010:	BASIC02 WRITE PROGRAM FOR JUNIOR COMPUTER	1140:	0279 A9 03	LDAXM ST0
0012:	WITH 80-9 BASIC	1150:	0281 28 42 02	JSR TABL END OF TEXT TO TABLE
0014:		1155:	0282 0A 01 03	LDAXM TABL
0016:	DATE:14-6-'83	1160:	0287 28 42 02	JSR STTABL CHECKSUM TO TABLE (WITHOUT SETTING)
0018:	0070: 0000	1165:	0290 0A 01 03	LDAXM ST0
0020:	POINTERS IN PAGE ZERO (BASIC)	1170:	029C 0E 0E 18	STA IEND SET INTERRUPT DISABLE MODE
0022:		1200:	029F A9 C0	LDAXM SC0
0024:		1210:	029E 00 10	STA ACTV SET SQUARE WAVE OUTPUT (PW)
0026:		1220:	0294 A9 01	LDAXM SE0
0028:	INT0 * 0000A	1230:	0298 00 18	STA T0C0 START TIMER ONE
0030:	INT0P * 0007E BEGINNING OF FREE SPACE POINTER	1240:	0299 20 40 03	JSR READER
0032:	INT0PD * 0002D	1250:	029C 20 10 03	JSR TEST STARTBIT+0
0034:	INT0M * 0004E END OF RAM POINTER	1260:	029F AD FF	LDAXM LSA SFFFF
0036:	INT0MD * 00005	1270:	02A2 AD 00	LDAXM S00
0038:		1280:	02A4 AA	OUTCMA L00A ONE BIT TO CARRY
0040:	0100: 0000	1290:	02A5 00 00	P0A
0042:	0120: 0200	1300:	02A6 00 05	B0C
0044:	0140: 0200	1310:	02A8 20 03	JSR ZERO ONE PERIOD OF 1200HZ (+0)
0046:	0160: 0200	1320:	02A0 28 46 03	HIGH J0R ONE TWO PERIODS OF 2400HZ (1-1)
0048:	0180: 0200	1330:	02B8 00 00	PLA
0050:	0200: 0200	1340:	02B1 00	DEY
0052:	0220: 0200	1350:	02B2 00 FF	LDAXM INT0P INTERRUPT NOT ZERO? THEN BRANCH
0054:	0240: 0200	1370:	02B4 28 46 03	JSR ONE STOPBIT+1
0056:	0260: 0200	1380:	02B5 28 46 03	JSR ONE STOPBIT+0
0058:	0280: 0200	1390:	02B6 5A 02	INC L0TABL +01 INCREMENT TABLE POINTER
0060:	0300: 0200	1400:	02B7 5A 02	LOW L0TABL +02
0062:	0320: 0200	1410:	02C5 5A 02	LDX L0TABL +01
0064:	0340: 0200	1420:	02C6 00 00	CFP
0066:	0360: 0200	1430:	02C8 00 00	ONE CARRY NOT END OF RAM? THEN BRANCH
0068:	0380: 0200	1440:	02CC 00 00	CFP
0070:	0400: 0200	1450:	02D0 00 00	ONE CARRY
0072:	0420: 0200	1460:	02D8 05 70	LDX 0000
0074:	0440: 0200	1470:	02D2 00 00	STA L0TABL +01 GO ON AT BEGINNING OF BASIC WORKSPACE
0076:	0460: 0200	1480:	02D5 A5 70	LDX 0070
0078:	0480: 0200	1490:	02D7 80 A1 02	STA L0TABL +02
0080:	0500: 0200	1500:	02D0 CC AA 02	CHPARE CFP STARTING NOT END OF TABLE? THEN BRANCH
0082:	0520: 0200	1510:	02D2 80 A1 02	CHPARE CFP STARTING NOT END OF TABLE? THEN BRANCH
0084:	0540: 0200	1520:	02D0 CC AA 02	CHPARE CFP STARTING NOT END OF TABLE? THEN BRANCH
0086:	0560: 0200	1530:	02D2 80 A1 02	CHPARE CFP STARTING NOT END OF TABLE? THEN BRANCH
0088:	0580: 0200	1540:	02D0 CC AA 02	CHPARE CFP STARTING NOT END OF TABLE? THEN BRANCH
0090:	0600: 0200	1550:	02D2 80 A1 02	CHPARE CFP STARTING NOT END OF TABLE? THEN BRANCH
0092:	0620: 0200	1560:	02D0 CC AA 02	CHPARE CFP STARTING NOT END OF TABLE? THEN BRANCH
0094:	0640: 0200	1570:	02D2 80 A1 02	CHPARE CFP STARTING NOT END OF TABLE? THEN BRANCH
0096:	0660: 0200	1580:	02D0 CC AA 02	CHPARE CFP STARTING NOT END OF TABLE? THEN BRANCH
0098:	0680: 0200	1590:	02D2 80 A1 02	CHPARE CFP STARTING NOT END OF TABLE? THEN BRANCH
0100:	0700: 0200	1600:	02D0 CC AA 02	CHPARE CFP STARTING NOT END OF TABLE? THEN BRANCH
0102:	0720: 0200	1610:	02D2 80 A1 02	CHPARE CFP STARTING NOT END OF TABLE? THEN BRANCH
0104:	0740: 0200	1620:	02D0 CC AA 02	CHPARE CFP STARTING NOT END OF TABLE? THEN BRANCH
0106:	0760: 0200	1630:	02D2 80 A1 02	CHPARE CFP STARTING NOT END OF TABLE? THEN BRANCH
0108:	0780: 0200	1640:	02D0 CC AA 02	CHPARE CFP STARTING NOT END OF TABLE? THEN BRANCH
0110:	0800: 0200	1650:	02D2 80 A1 02	CHPARE CFP STARTING NOT END OF TABLE? THEN BRANCH
0112:	0820: 0200	1660:	02D0 CC AA 02	CHPARE CFP STARTING NOT END OF TABLE? THEN BRANCH
0114:	0840: 0200	1670:	02D2 80 A1 02	CHPARE CFP STARTING NOT END OF TABLE? THEN BRANCH
0116:	0860: 0200	1680:	02D0 CC AA 02	CHPARE CFP STARTING NOT END OF TABLE? THEN BRANCH
0118:	0880: 0200	1690:	02D2 80 A1 02	CHPARE CFP STARTING NOT END OF TABLE? THEN BRANCH
0120:	0900: 0200	1700:	02D0 CC AA 02	CHPARE CFP STARTING NOT END OF TABLE? THEN BRANCH
0122:	0920: 0200	1710:	02D2 80 A1 02	CHPARE CFP STARTING NOT END OF TABLE? THEN BRANCH
0124:	0940: 0200	1720:	02D0 CC AA 02	CHPARE CFP STARTING NOT END OF TABLE? THEN BRANCH
0126:	0960: 0200	1730:	02D2 80 A1 02	CHPARE CFP STARTING NOT END OF TABLE? THEN BRANCH
0128:	0980: 0200	1740:	02D0 CC AA 02	CHPARE CFP STARTING NOT END OF TABLE? THEN BRANCH
0130:	1000: 0200	1750:	02D2 80 A1 02	CHPARE CFP STARTING NOT END OF TABLE? THEN BRANCH
0132:	1020: 0200	1760:	02D0 CC AA 02	CHPARE CFP STARTING NOT END OF TABLE? THEN BRANCH
0134:	1040: 0200	1770:	02D2 80 A1 02	CHPARE CFP STARTING NOT END OF TABLE? THEN BRANCH
0136:	1060: 0200	1780:	02D0 CC AA 02	CHPARE CFP STARTING NOT END OF TABLE? THEN BRANCH
0138:	1080: 0200	1790:	02D2 80 A1 02	CHPARE CFP STARTING NOT END OF TABLE? THEN BRANCH
0140:	1100: 0200	1800:	02D0 CC AA 02	CHPARE CFP STARTING NOT END OF TABLE? THEN BRANCH
0142:	1120: 0200	1810:	02D2 80 A1 02	CHPARE CFP STARTING NOT END OF TABLE? THEN BRANCH
0144:	1140: 0200	1820:	02D0 CC AA 02	CHPARE CFP STARTING NOT END OF TABLE? THEN BRANCH
0146:	1160: 0200	1830:	02D2 80 A1 02	CHPARE CFP STARTING NOT END OF TABLE? THEN BRANCH
0148:	1180: 0200	1840:	02D0 CC AA 02	CHPARE CFP STARTING NOT END OF TABLE? THEN BRANCH
0150:	1200: 0200	1850:	02D2 80 A1 02	CHPARE CFP STARTING NOT END OF TABLE? THEN BRANCH
0152:	1220: 0200	1860:	02D0 CC AA 02	CHPARE CFP STARTING NOT END OF TABLE? THEN BRANCH
0154:	1240: 0200	1870:	02D2 80 A1 02	CHPARE CFP STARTING NOT END OF TABLE? THEN BRANCH
0156:	1260: 0200	1880:	02D0 CC AA 02	CHPARE CFP STARTING NOT END OF TABLE? THEN BRANCH
0158:	1280: 0200	1890:	02D2 80 A1 02	CHPARE CFP STARTING NOT END OF TABLE? THEN BRANCH
0160:	1300: 0200	1900:	02D0 CC AA 02	CHPARE CFP STARTING NOT END OF TABLE? THEN BRANCH
0162:	1320: 0200	1910:	02D2 80 A1 02	CHPARE CFP STARTING NOT END OF TABLE? THEN BRANCH
0164:	1340: 0200	1920:	02D0 CC AA 02	CHPARE CFP STARTING NOT END OF TABLE? THEN BRANCH
0166:	1360: 0200	1930:	02D2 80 A1 02	CHPARE CFP STARTING NOT END OF TABLE? THEN BRANCH
0168:	1380: 0200	1940:	02D0 CC AA 02	CHPARE CFP STARTING NOT END OF TABLE? THEN BRANCH
0170:	1400: 0200	1950:	02D2 80 A1 02	CHPARE CFP STARTING NOT END OF TABLE? THEN BRANCH
0172:	1420: 0200	1960:	02D0 CC AA 02	CHPARE CFP STARTING NOT END OF TABLE? THEN BRANCH
0174:	1440: 0200	1970:	02D2 80 A1 02	CHPARE CFP STARTING NOT END OF TABLE? THEN BRANCH
0176:	1460: 0200	1980:	02D0 CC AA 02	CHPARE CFP STARTING NOT END OF TABLE? THEN BRANCH
0178:	1480: 0200	1990:	02D2 80 A1 02	CHPARE CFP STARTING NOT END OF TABLE? THEN BRANCH
0180:	1500: 0200	2000:	02D0 CC AA 02	CHPARE CFP STARTING NOT END OF TABLE? THEN BRANCH
0182:	1520: 0200	2010:	02D2 80 A1 02	CHPARE CFP STARTING NOT END OF TABLE? THEN BRANCH
0184:	1540: 0200	2020:	02D0 CC AA 02	CHPARE CFP STARTING NOT END OF TABLE? THEN BRANCH
0186:	1560: 0200	2030:	02D2 80 A1 02	CHPARE CFP STARTING NOT END OF TABLE? THEN BRANCH
0188:	1580: 0200	2040:	02D0 CC AA 02	CHPARE CFP STARTING NOT END OF TABLE? THEN BRANCH
0190:	1600: 0200	2050:	02D2 80 A1 02	CHPARE CFP STARTING NOT END OF TABLE? THEN BRANCH
0192:	1620: 0200	2060:	02D0 CC AA 02	CHPARE CFP STARTING NOT END OF TABLE? THEN BRANCH
0194:	1640: 0200	2070:	02D2 80 A1 02	CHPARE CFP STARTING NOT END OF TABLE? THEN BRANCH
0196:	1660: 0200	2080:	02D0 CC AA 02	CHPARE CFP STARTING NOT END OF TABLE? THEN BRANCH
0198:	1680: 0200	2090:	02D2 80 A1 02	CHPARE CFP STARTING NOT END OF TABLE? THEN BRANCH
0200:	1700: 0200	2100:	02D0 CC AA 02	CHPARE CFP STARTING NOT END OF TABLE? THEN BRANCH
0202:	1720: 0200	2110:	02D2 80 A1 02	CHPARE CFP STARTING NOT END OF TABLE? THEN BRANCH
0204:	1740: 0200	2120:	02D0 CC AA 02	CHPARE CFP STARTING NOT END OF TABLE? THEN BRANCH
0206:	1760: 0200	2130:	02D2 80 A1 02	CHPARE CFP STARTING NOT END OF TABLE? THEN BRANCH
0208:	1780: 0200	2140:	02D0 CC AA 02	CHPARE CFP STARTING NOT END OF TABLE? THEN BRANCH
0210:	1800: 0200	2150:	02D2 80 A1 02	CHPARE CFP STARTING NOT END OF TABLE? THEN BRANCH
0212:	1820: 0200	2160:	02D0 CC AA 02	CHPARE CFP STARTING NOT END OF TABLE? THEN BRANCH
0214:	1840: 0200	2170:	02D2 80 A1 02	CHPARE CFP STARTING NOT END OF TABLE? THEN BRANCH
0216:	1860: 0200	2180:	02D0 CC AA 02	CHPARE CFP STARTING NOT END OF TABLE? THEN BRANCH
0218:	1880: 0200	2190:	02D2 80 A1 02	CHPARE CFP STARTING NOT END OF TABLE? THEN BRANCH
0220:	1900: 0200	2200:	02D0 CC AA 02	CHPARE CFP STARTING NOT END OF TABLE? THEN BRANCH
0222:	1920: 0200	2210:	02D2 80 A1 02	CHPARE CFP STARTING NOT END OF TABLE? THEN BRANCH
0224:	1940: 0200	2220:	02D0 CC AA 02	CHPARE CFP STARTING NOT END OF TABLE? THEN BRANCH
0226:	1960: 0200	2230:	02D2 80 A1 02	CHPARE CFP STARTING NOT END OF TABLE? THEN BRANCH
0228:	1980: 0200	2240:	02D0 CC AA 02	CHPARE CFP STARTING NOT END OF TABLE? THEN BRANCH
0230:	2000: 0200	2250:	02D2 80 A1 02	CHPARE CFP STARTING NOT END OF TABLE? THEN BRANCH
0232:	2020: 0200	2260:	02D0 CC AA 02	CHPARE CFP STARTING NOT END OF TABLE? THEN BRANCH
0234:	2040: 0200	2270:	02D2 80 A1 02	CHPARE CFP STARTING NOT END OF TABLE? THEN BRANCH
0236:	2060: 0200	2280:	02D0 CC AA 02	CHPARE CFP STARTING NOT END OF TABLE? THEN BRANCH
0238:	2080: 0200	2290:	02D2 80 A1 02	CHPARE CFP STARTING NOT END OF TABLE? THEN BRANCH
0240:	2100: 0200	2300:	02D0 CC AA 02	CHPARE CFP STARTING NOT END OF TABLE? THEN BRANCH
0242:	2120: 0200	2310:	02D2 80 A1 02	CHPARE CFP STARTING NOT END OF TABLE? THEN BRANCH
0244:	2140: 0200	2320:	02D0 CC AA 02	CHPARE CFP STARTING NOT END OF TABLE? THEN BRANCH
0246:	2160: 0200	2330:	02D2 80 A1 02	CHPARE CFP STARTING NOT END OF TABLE? THEN BRANCH
0248:	2180: 0200	2340:	02D0 CC AA 02	CHPARE CFP STARTING NOT END OF TABLE? THEN BRANCH
0250:	2200: 0200	2350:	02D2 80 A1 02	CHPARE CFP STARTING NOT END OF TABLE? THEN BRANCH
0252:	2220: 0200	2360:	02D0 CC AA 02	CHPARE CFP STARTING NOT END OF TABLE? THEN BRANCH
0254:	2240: 0200	2370:	02D2 80 A1 02	CHPARE CFP STARTING NOT END OF TABLE? THEN BRANCH
0256:	2260: 0200	2380:	02D0 CC AA 02	CHPARE CFP STARTING NOT END OF TABLE? THEN BRANCH
0258:	2280: 0200	2390:	02D2 80 A1 02	CHPARE CFP STARTING NOT END OF TABLE? THEN BRANCH
0260:	2300: 0200	2400:	02D0 CC AA 02	CHPARE CFP STARTING NOT END OF TABLE? THEN BRANCH
0262:	2320: 0200	2410:	02D2 80 A1 02	CHPARE CFP STARTING NOT END OF TABLE? THEN BRANCH
0264:	2340: 0200	2420:	02D0 CC AA 02	CHPARE CFP STARTING NOT END OF TABLE? THEN BRANCH
0266:	2360: 0200	2430:	02D2 80 A1 02	CHPARE CFP STARTING NOT END OF TABLE? THEN BRANCH
0268:	2380: 0200	2440:	02D0 CC AA 02	CHPARE CFP STARTING NOT END OF TABLE? THEN BRANCH
0270:	2400: 0200	2450:	02D2 80 A1 02	CHPARE CFP STARTING NOT END OF TABLE? THEN BRANCH
0272:	2420: 0200	2460:	02D0 CC AA 02	CHPARE CFP STARTING NOT END OF TABLE? THEN BRANCH
0274:	2440: 0200	2470:	02D2 80 A1 02	CHPARE CFP STARTING NOT END OF TABLE? THEN BRANCH
0276:	2460: 0200	2480:	02D0 CC AA 02	CHPARE CFP STARTING NOT END OF TABLE? THEN BRANCH
0278:	2480: 0200	2490:	02D2 80 A1 02	CHPARE CFP STARTING NOT END OF TABLE? THEN BRANCH
0280:	2500: 0200	2500:	02D0 CC AA 02	CHPARE CFP STARTING NOT END OF TABLE? THEN BRANCH

computer is finished with the listing and gives the 'OK' or 'CHECKSUM ERROR' message. Then by simply working in BASIC, you can check the program and correct it. There is also a possibility that the computer may not recognize the end of the program and carries on as if it were reading the program, and the hex display remains lighting. In this case the RST key could be pressed, but then the BASIC would have to be read in again. That is not the ideal situation. A better solution is to look for the end of another Basicode program on the tape and play this out. The computer will then recognize this end and will report back on the screen. Of course, the last part of the program read in will no longer be correct but at least you can examine the

part of the program that is correct and in this case the BASIC does not have to be read in again. If the program that must be read in is too large for the available memory space, the computer returns with 'OUT OF MEMORY', and no listing appears. If a listing of the part that is written in is required it can be obtained as follows:
POKE 8256,156 : POKE 8257,4 : X = USR(X)
(POKE 574,156 : POKE 575,226 : X = USR(X))
followed by a (carriage) return.
Writing
A BASIC program is written out in the following manner using Basicode:

0020:	MARCOE READ PROGRAM FOR JUNIOR COMPUTER	1474:	MACD AD 06 04	INCRPT	LDA	STAIN0 #02
0021:	WITH KB-9 BASIC	1480:	MACD AD C8 04	CMF	LDIND	#02
0022:		1490:	MDI D8 26	AND	RETNAS	NOT END OF TABLE THEN BRANCH
0023:	DATE:14-6-'83	1500:	MDIS AD C8 04	LDW	STAIN0 #01	
0024:		1510:	MDID AD 0F 04	CMF	LDIND	#01
0025:		1520:	MDIS AD 0F 04	AND	RETNAS	
0026:	ORG 0000H	1530:	MDID AD F0 03	LDA	SIVL	
0027:	ORG 0000H	1540:	MDIS AD 57 24	STA	INVEL	RESSET INPUT VECTOR
0028:	POINTERS IN PAGE ZERO (BASIC)	1550:	MDIC AD 5A 03	LDA	INVEL	
0029:		1560:	MDIS AD 56 24	STA	INVEL	
0030:	INPDEL = 0007E BEGINNING OF FREE SPACE POINTER	1570:	MDIC AD F4 03	LDA	CRUM	
0031:	00000H	1580:	MDIC F0 05	REQ	RETURN	NO CHECKSUM ERROR? THEN BRANCH
0032:	00000H	1590:	MDIC F0 05	LDW	SIZ	
0033:	00000H	1600:	MDIC F0 05	REQ	MESDY	"CHECKSUM ERROR" MESSAGE
0034:	4652-IC REGISTER	1610:	MDIC F0 05	LDW	LYN0	SIZ
0035:		1620:	MDIC F0 05	REQ	MESDY	"OK" MESSAGE
0036:	PCR = 01000 PERIPHERAL CONTROL REGISTER	1630:	MDIC F0 05	LDW	LYN0	SIZ
0037:	IFR = 01000 INTERRUPT FLAG REGISTER	1640:	MDIC F0 05	REQ	RTS	CARRIAGE RETURN
0038:	IER = 01000 INTERRUPT ENABLE REGISTER	1650:	MDIC F0 05	REQ	RTS	
0039:		1660:	MDIC F0 05	REQ	RTS	
0040:	4532-IC REGISTER	1670:	MDIC F0 05	REQ	RTS	
0041:		1680:	MDIC F0 05	REQ	RTS	
0042:		1690:	MDIC F0 05	REQ	RTS	
0043:	4532-IC REGISTER	1700:	MDIC F0 05	REQ	RTS	
0044:		1710:	MDIC F0 05	REQ	RTS	
0045:	PAD = 51000 DATA REGISTER OF PORT A	1720:	MDIC F0 05	REQ	RTS	
0046:	00000H	1730:	MDIC F0 05	REQ	RTS	
0047:	CNT0 = 51005 CLRAT (INTERUPT DISABLE)	1740:	MDIC F0 05	REQ	RTS	
0048:		1750:	MDIC F0 05	REQ	RTS	
0049:	INPUT VECTOR (BASIC)	1760:	MDIC F0 05	REQ	RTS	
0050:		1770:	MDIC F0 05	REQ	RTS	
0051:	INVELC = 52057 INPUT VECTOR	1780:	MDIC F0 05	REQ	RTS	
0052:	INVELC = 52058	1790:	MDIC F0 05	REQ	RTS	
0053:	TEMPORARY DATA BUFFERS	1800:	MDIC F0 05	REQ	RTS	
0054:		1810:	MDIC F0 05	REQ	RTS	
0055:	CRDUM = 50034 CHECKSUM	1820:	MDIC F0 05	REQ	RTS	
0056:	CRDEL = 50035 PERIOD COUNTER	1830:	MDIC F0 05	REQ	RTS	
0057:	PCWTE = 50036	1840:	MDIC F0 05	REQ	RTS	
0058:	CRDUM = 50037 PERIODICS	1850:	MDIC F0 05	REQ	RTS	
0059:	CRDUM = 50038 HALF PERIODICS	1860:	MDIC F0 05	REQ	RTS	
0060:	CRDUM = 50039	1870:	MDIC F0 05	REQ	RTS	
0061:	CRDUM = 50040	1880:	MDIC F0 05	REQ	RTS	
0062:	CRDUM = 50041	1890:	MDIC F0 05	REQ	RTS	
0063:	CRDUM = 50042	1900:	MDIC F0 05	REQ	RTS	
0064:	CRDUM = 50043	1910:	MDIC F0 05	REQ	RTS	
0065:	CRDUM = 50044	1920:	MDIC F0 05	REQ	RTS	
0066:	CRDUM = 50045	1930:	MDIC F0 05	REQ	RTS	
0067:	CRDUM = 50046	1940:	MDIC F0 05	REQ	RTS	
0068:	CRDUM = 50047	1950:	MDIC F0 05	REQ	RTS	
0069:	CRDUM = 50048	1960:	MDIC F0 05	REQ	RTS	
0070:	CRDUM = 50049	1970:	MDIC F0 05	REQ	RTS	
0071:	CRDUM = 50050	1980:	MDIC F0 05	REQ	RTS	
0072:	CRDUM = 50051	1990:	MDIC F0 05	REQ	RTS	
0073:	CRDUM = 50052	2000:	MDIC F0 05	REQ	RTS	
0074:	CRDUM = 50053	2010:	MDIC F0 05	REQ	RTS	
0075:	CRDUM = 50054	2020:	MDIC F0 05	REQ	RTS	
0076:	CRDUM = 50055	2030:	MDIC F0 05	REQ	RTS	
0077:	CRDUM = 50056	2040:	MDIC F0 05	REQ	RTS	
0078:	CRDUM = 50057	2050:	MDIC F0 05	REQ	RTS	
0079:	CRDUM = 50058	2060:	MDIC F0 05	REQ	RTS	
0080:	CRDUM = 50059	2070:	MDIC F0 05	REQ	RTS	
0081:	CRDUM = 50060	2080:	MDIC F0 05	REQ	RTS	
0082:	CRDUM = 50061	2090:	MDIC F0 05	REQ	RTS	
0083:	CRDUM = 50062	2100:	MDIC F0 05	REQ	RTS	
0084:	CRDUM = 50063	2110:	MDIC F0 05	REQ	RTS	
0085:	CRDUM = 50064	2120:	MDIC F0 05	REQ	RTS	
0086:	CRDUM = 50065	2130:	MDIC F0 05	REQ	RTS	
0087:	CRDUM = 50066	2140:	MDIC F0 05	REQ	RTS	
0088:	CRDUM = 50067	2150:	MDIC F0 05	REQ	RTS	
0089:	CRDUM = 50068	2160:	MDIC F0 05	REQ	RTS	
0090:	CRDUM = 50069	2170:	MDIC F0 05	REQ	RTS	
0091:	CRDUM = 50070	2180:	MDIC F0 05	REQ	RTS	
0092:	CRDUM = 50071	2190:	MDIC F0 05	REQ	RTS	
0093:	CRDUM = 50072	2200:	MDIC F0 05	REQ	RTS	
0094:	CRDUM = 50073	2210:	MDIC F0 05	REQ	RTS	
0095:	CRDUM = 50074	2220:	MDIC F0 05	REQ	RTS	
0096:	CRDUM = 50075	2230:	MDIC F0 05	REQ	RTS	
0097:	CRDUM = 50076	2240:	MDIC F0 05	REQ	RTS	
0098:	CRDUM = 50077	2250:	MDIC F0 05	REQ	RTS	
0099:	CRDUM = 50078	2260:	MDIC F0 05	REQ	RTS	
0100:	CRDUM = 50079	2270:	MDIC F0 05	REQ	RTS	
0101:	CRDUM = 50080	2280:	MDIC F0 05	REQ	RTS	
0102:	CRDUM = 50081	2290:	MDIC F0 05	REQ	RTS	
0103:	CRDUM = 50082	2300:	MDIC F0 05	REQ	RTS	
0104:	CRDUM = 50083	2310:	MDIC F0 05	REQ	RTS	
0105:	CRDUM = 50084	2320:	MDIC F0 05	REQ	RTS	
0106:	CRDUM = 50085	2330:	MDIC F0 05	REQ	RTS	
0107:	CRDUM = 50086	2340:	MDIC F0 05	REQ	RTS	
0108:	CRDUM = 50087	2350:	MDIC F0 05	REQ	RTS	
0109:	CRDUM = 50088	2360:	MDIC F0 05	REQ	RTS	
0110:	CRDUM = 50089	2370:	MDIC F0 05	REQ	RTS	
0111:	CRDUM = 50090	2380:	MDIC F0 05	REQ	RTS	
0112:	CRDUM = 50091	2390:	MDIC F0 05	REQ	RTS	
0113:	CRDUM = 50092	2400:	MDIC F0 05	REQ	RTS	
0114:	CRDUM = 50093	2410:	MDIC F0 05	REQ	RTS	
0115:	CRDUM = 50094	2420:	MDIC F0 05	REQ	RTS	
0116:	CRDUM = 50095	2430:	MDIC F0 05	REQ	RTS	
0117:	CRDUM = 50096	2440:	MDIC F0 05	REQ	RTS	
0118:	CRDUM = 50097	2450:	MDIC F0 05	REQ	RTS	
0119:	CRDUM = 50098	2460:	MDIC F0 05	REQ	RTS	
0120:	CRDUM = 50099	2470:	MDIC F0 05	REQ	RTS	
0121:	CRDUM = 50100	2480:	MDIC F0 05	REQ	RTS	
0122:	CRDUM = 50101	2490:	MDIC F0 05	REQ	RTS	
0123:	CRDUM = 50102	2500:	MDIC F0 05	REQ	RTS	
0124:	CRDUM = 50103	2510:	MDIC F0 05	REQ	RTS	
0125:	CRDUM = 50104	2520:	MDIC F0 05	REQ	RTS	
0126:	CRDUM = 50105	2530:	MDIC F0 05	REQ	RTS	
0127:	CRDUM = 50106	2540:	MDIC F0 05	REQ	RTS	
0128:	CRDUM = 50107	2550:	MDIC F0 05	REQ	RTS	
0129:	CRDUM = 50108	2560:	MDIC F0 05	REQ	RTS	
0130:	CRDUM = 50109	2570:	MDIC F0 05	REQ	RTS	
0131:	CRDUM = 50110	2580:	MDIC F0 05	REQ	RTS	
0132:	CRDUM = 50111	2590:	MDIC F0 05	REQ	RTS	
0133:	CRDUM = 50112	2600:	MDIC F0 05	REQ	RTS	
0134:	CRDUM = 50113	2610:	MDIC F0 05	REQ	RTS	
0135:	CRDUM = 50114	2620:	MDIC F0 05	REQ	RTS	
0136:	CRDUM = 50115	2630:	MDIC F0 05	REQ	RTS	
0137:	CRDUM = 50116	2640:	MDIC F0 05	REQ	RTS	
0138:	CRDUM = 50117	2650:	MDIC F0 05	REQ	RTS	
0139:	CRDUM = 50118	2660:	MDIC F0 05	REQ	RTS	
0140:	CRDUM = 50119	2670:	MDIC F0 05	REQ	RTS	
0141:	CRDUM = 50120	2680:	MDIC F0 05	REQ	RTS	
0142:	CRDUM = 50121	2690:	MDIC F0 05	REQ	RTS	
0143:	CRDUM = 50122	2700:	MDIC F0 05	REQ	RTS	
0144:	CRDUM = 50123	2710:	MDIC F0 05	REQ	RTS	
0145:	CRDUM = 50124	2720:	MDIC F0 05	REQ	RTS	
0146:	CRDUM = 50125	2730:	MDIC F0 05	REQ	RTS	
0147:	CRDUM = 50126	2740:	MDIC F0 05	REQ	RTS	
0148:	CRDUM = 50127	2750:	MDIC F0 05	REQ	RTS	
0149:	CRDUM = 50128	2760:	MDIC F0 05	REQ	RTS	
0150:	CRDUM = 50129	2770:	MDIC F0 05	REQ	RTS	
0151:	CRDUM = 50130	2780:	MDIC F0 05	REQ	RTS	
0152:	CRDUM = 50131	2790:	MDIC F0 05	REQ	RTS	
0153:	CRDUM = 50132	2800:	MDIC F0 05	REQ	RTS	
0154:	CRDUM = 50133	2810:	MDIC F0 05	REQ	RTS	
0155:	CRDUM = 50134	2820:	MDIC F0 05	REQ	RTS	
0156:	CRDUM = 50135	2830:	MDIC F0 05	REQ	RTS	
0157:	CRDUM = 50136	2840:	MDIC F0 05	REQ	RTS	
0158:	CRDUM = 50137	2850:	MDIC F0 05	REQ	RTS	
0159:	CRDUM = 50138	2860:	MDIC F0 05	REQ	RTS	
0160:	CRDUM = 50139	2870:	MDIC F0 05	REQ	RTS	
0161:	CRDUM = 50140	2880:	MDIC F0 05	REQ	RTS	
0162:	CRDUM = 50141	2890:	MDIC F0 05	REQ	RTS	
0163:	CRDUM = 50142	2900:	MDIC F0 05	REQ	RTS	
0164:	CRDUM = 50143	2910:	MDIC F0 05	REQ	RTS	
0165:	CRDUM = 50144	2920:	MDIC F0 05	REQ	RTS	
0166:	CRDUM = 50145	2930:	MDIC F0 05	REQ	RTS	
0167:	CRDUM = 50146	2940:	MDIC F0 05	REQ	RTS	
0168:	CRDUM = 50147	2950:	MDIC F0 05	REQ	RTS	
0169:	CRDUM = 50148	2960:	MDIC F0 05	REQ	RTS	
0170:	CRDUM = 50149	2970:	MDIC F0 05	REQ	RTS	
0171:	CRDUM = 50150	2980:	MDIC F0 05	REQ	RTS	
0172:	CRDUM = 50151	2990:	MDIC F0 05	REQ	RTS	
0173:	CRDUM = 50152	3000:	MDIC F0 05	REQ	RTS	
0174:	CRDUM = 50153	3010:	MDIC F0 05	REQ	RTS	
0175:	CRDUM = 50154	3020:	MDIC F0 05	REQ	RTS	
0176:	CRDUM = 50155	3030:	MDIC F0 05	REQ	RTS	
0177:	CRDUM = 50156	3040:	MDIC F0 05	REQ	RTS	
0178:	CRDUM = 50157	3050:	MDIC F0 05	REQ	RTS	
0179:	CRDUM = 50158	3060:	MDIC F0 05	REQ	RTS	
0180:	CRDUM = 50159	3070:	MDIC F0 05	REQ	RTS	
0181:	CRDUM = 50160	3080:	MDIC F0 05	REQ	RTS	
0182:	CRDUM = 50161	3090				

Table 2

M	HEXDUMP: 0200,0363
0	1 2 3 4 5 6 7 8 9 A B C D E F
0200:	AD 52 2A AC 53 2A 8D F0 03 8C F1 83 A9 42 AB 02
0210:	8D 52 2A AC 53 2A A5 84 A4 85 8D F2 83 8C F3 03
0220:	A5 77 AB 82 85 84 A5 85 7E A1 79 8D 8B 8E 8C 84
0230:	4A 82 8D AB 82 8C A1 82 A9 8D 8D F4 83 8D FB 03
0240:	A9 82 C9 8A F8 3B 89 8B 8D FF F4 84 83 8D F4
0250:	83 8E 49 82 83 8E 82 A5 85 8D 4A 82 8D 86 8E
0260:	A5 84 CD 49 82 D0 8F A9 FF 8D FB 83 85 78 8D 49
0270:	82 A5 79 8D 4A 82 68 48 98 48 A9 8D 28 42 82 A9
0280:	83 28 42 AD F4 83 28 42 82 A9 8D 28 42 82 A9
0290:	CD 8D 8B 18 A9 81 8D 85 18 28 2B 83 28 39 83 AD
02A0:	8F FF A8 08 4A 48 8B 85 28 39 83 78 83 28 46 93
02B0:	88 88 D8 FF 28 46 83 28 46 83 1E A8 82 D8 83 8E
02C0:	A1 82 AC A1 82 AE 82 C4 85 D8 8E 84 84 D8 8A
02D0:	A5 78 8D AB 82 A5 79 8D A3 82 CC 4A 82 D8 8D 8C
02E0:	49 82 D8 8E 28 2B 83 8C 8B 18 AD F2 83 AC F3 83
02F0:	85 84 84 8A AD F0 83 AC F1 83 85 5D 2A 8C 53 2A
0300:	AD FB 83 F8 20 A5 79 85 78 85 7D 85 7F 84 78 C8
0310:	8C 8B 8A 7A 8A 7C 8A 7E 8A 7E 8C 8D 86 18 A9 78
0320:	AD 2C 20 59 85 68 A8 68 4C 83 8D 80 27 AB 17 20
0330:	46 83 CD 8A DA FA 88 D8 F7 68 A5 9F 8D 86 18 A9 81
0340:	8D 87 18 AC 53 83 28 49 83 A9 CD 86 18 A9 81
0350:	8D 87 18 AD 8A 18 2C 8D 18 58 FB AD 04 18 2C 8D
0360:	18 58 FB 68

JUNIOR

M	HEXDUMP: 0400,0598
0	1 2 3 4 5 6 7 8 9 A B C D E F
0400:	A9 7F 8D 8C 18 5D 8D F4 83 8C F1 83 A9 73 8D
0410:	82 1A A5 7E 8D 85 84 A6 7F 8E 84 85 8B 63 8E 66
0420:	84 A9 10 8D F6 83 A9 26 2D 4D 85 28 FD 84 C9 22
0430:	90 8F C9 4E 28 8E 85 F5 83 D1 F8 28 48 98
0440:	CE F6 81 D8 E6 8A 38 89 8C 8D F7 83 8D 83 28
0450:	88 05 8D F7 83 90 7F 8B 88 28 88 05 C8 F7 83 98
0460:	F8 28 24 85 8D 8E 85 85 CD 66 84 D8 DF A5 8D
0470:	8E 86 84 A5 85 CD 66 84 D8 DF A5 8D CD 65 84 8D
0480:	D8 AB 28 28 59 85 A9 67 8D 82 1A 68 28 88 85 CD
0490:	87 83 98 F8 28 24 85 A9 67 8D 82 1A 68 28 88 85 CD
04A0:	84 8E 84 A5 85 CD 66 84 D8 DF A5 8D CD 65 84 8D
04B0:	8C F8 A3 83 A8 8E 84 8D 57 24 AC 58 24 68 F9 83
04C0:	FF AB 28 34 13 8E 8F 84 D8 1E CE 84 AD 66 84
04D0:	CD 8E 84 8E 28 65 84 CD BF 84 D8 1E CE 84 AD 66 84
04E0:	8D 57 24 AD FA 83 8D 58 24 AD F4 83 F8 85 AD 12
04F0:	28 59 85 8D 25 28 59 85 A9 8D 68 28 88 85
0500:	A9 82 2C 8D 1B F8 FB 8D 8D 18 A9 A1 4D 8C 18 8D
0510:	8C 18 A9 FF AA 4D F6 1A 8E F5 1A A9 18 6D F8 83
0520:	8E F8 68 A9 A9 55 2D 4D 85 A8 88 28 FD 84 CD
0530:	87 83 8D 8B 28 FD 84 38 8B 81 18 68 A 88 D8 8E
0540:	48 83 F4 83 8D F4 83 68 28 7F 68 A9 69 8D 8A 1A
0550:	AD 82 1A 49 82 8D 82 1A 68 89 85 C9 83 87 87
0560:	28 34 13 CD AC 59 85 68 8D 8A 4F 55 24 48 46
0570:	28 4D 45 4D 4D 4F 52 59 8A 8D 83 8D 8A 43 48 45 4F
0580:	48 53 55 4D 4F 52 52 4F 52 8A 8D 83 8D 8A 4F
0590:	48 53 55 4D 4F 52 4E 45 57 8A 8D 83

Table 2. The hexdump for the translation program for the Junior with KB-9-BASIC.

JUNIOR

Table 3

M	HEXDUMP: E000,E163
0	1 2 3 4 5 6 7 8 9 A B C D E F
E000:	AD 11 23 8C 12 23 8D F8 81 9A A B C A9 41 A8 8E
E010:	8D 11 23 8C 12 23 A5 84 A4 85 8D F2 83 8C F3 E1
E020:	A9 7F AB 82 85 84 A5 85 7E A1 79 8D 8B 8E 8C 84
E030:	4A 82 8D AB 82 8C A1 82 A9 8D 8D F4 83 8D FB E1
E040:	A9 82 C9 8A F8 3B 89 8B 8D FF F4 84 83 8D F4
E050:	E1 4E 49 82 83 8E 82 A5 85 8D 4A 82 8D 86 8E
E060:	A5 84 CD 49 82 D0 8F A9 FF 8D FB 83 85 78 8D 49
E070:	82 A5 79 8D 4A 82 68 48 98 48 A9 8D 28 42 82 A9
E080:	83 28 42 AD F4 83 28 42 82 A9 8D 28 42 82 A9
E090:	CD 8D 8B 18 A9 81 8D 85 18 28 2B 83 28 39 83 AD
E0A0:	8F FF A8 08 4A 48 8B 85 28 39 83 78 83 28 46 93
E0B0:	88 88 D8 FF 28 46 83 28 46 83 1E A8 82 D8 83 8E
E0C0:	A1 82 AC A1 82 AE 82 C4 85 D8 8E 84 84 D8 8A
E0D0:	A5 78 8D AB 82 A5 79 8D A3 82 CC 4A 82 D8 8D 8C
E0E0:	49 82 D8 8E 28 2B 83 8C 8B 18 AD F2 83 AC F3 E1
E0F0:	85 84 84 8A AD F0 83 AC F1 83 85 5D 2A 8C 53 2A
E100:	AD FB 83 F8 20 A5 79 85 78 85 7D 85 7F A4 78 C8
E110:	8C 8B 8A 7A 8A 7C 8A 7E 8A 7E 8C 8D 86 18 A9 78
E120:	AD 2C 20 59 85 68 A8 68 4C 83 8D 80 27 AB 17 20
E130:	46 83 CD 8A DA FA 88 D8 F7 68 A5 9F 8D 86 18 A9 81
E140:	8D 87 F8 AC 53 E1 38 49 E1 A9 CE 8D 86 18 A9 81
E150:	8D 87 F8 AD 84 F8 2C 8D F8 58 FB AD 04 18 2C 8D
E160:	F8 58 FB 68

JUNIOR

M	HEXDUMP: E200,E398
0	1 2 3 4 5 6 7 8 9 A B C D E F
E200:	A9 7F 8D 8C 18 5D 8D F4 83 8C F1 83 A9 73 8D 8E
E210:	82 1A A5 7E 8D 85 84 A6 7F 8E 84 85 8B 63 8E 66
E220:	84 A9 10 8D F6 83 A9 26 2D 4D 85 28 FD 84 C9 22
E230:	90 8F C9 4E 28 8E 85 F5 83 D1 F8 28 48 98
E240:	CE F6 81 D8 E6 8A 38 89 8C 8D F7 83 8D 83 28
E250:	88 05 8D F7 83 90 7F 8B 88 28 88 05 C8 F7 83 98
E260:	F8 28 24 85 8D 8E 85 85 CD 66 84 D8 DF A5 8D
E270:	8E 86 84 A5 85 CD 66 84 D8 DF A5 8D CD 65 84 8D
E280:	D8 AB 28 28 59 85 A9 67 8D 82 1A 68 28 88 85 CD
E290:	87 83 98 F8 28 24 85 A9 67 8D 82 1A 68 28 88 85 CD
E2A0:	84 8E 84 A5 85 CD 66 84 D8 DF A5 8D CD 65 84 8D
E2B0:	8C F8 A3 83 A8 8E 84 8D 57 24 AC 58 24 68 F9 83
E2C0:	FF AB 28 34 13 8E 8F 84 D8 1E CE 84 AD 66 84
E2D0:	CD 8E 84 8E 28 65 84 CD BF 84 D8 1E CE 84 AD 66 84
E2E0:	8D 57 24 AD FA 83 8D 58 24 AD F4 83 F8 85 AD 12
E2F0:	28 59 85 8D 25 28 59 85 A9 8D 68 28 88 85
E300:	A9 82 2C 8D 1B F8 FB 8D 8D 18 A9 A1 4D 8C 18 8D
E310:	8C 18 A9 FF AA 4D F6 1A 8E F5 1A A9 18 6D F8 83
E320:	8E F8 68 A9 A9 55 2D 4D 85 A8 88 28 FD 84 CD
E330:	87 83 8D 8B 28 FD 84 38 8B 81 18 68 A 88 D8 8E
E340:	48 83 F4 83 8D F4 83 68 28 7F 68 A9 69 8D 8A 1A
E350:	AD 82 1A 49 82 8D 82 1A 68 89 85 C9 83 87 87
E360:	28 34 13 CD AC 59 85 68 8D 8A 4F 55 24 48 46
E370:	28 4D 45 4D 4D 4F 52 59 8A 8D 83 8D 8A 43 48 45 4F
E380:	48 53 55 4D 4F 52 52 4F 52 8A 8D 83 8D 8A 43 48 45 4F
E390:	48 53 55 4D 4F 52 4E 45 57 8A 8D 83

Table 3. Hexdump for the translation program for the DOS Junior.

JUNIOR

POKE 8256,0 : POKE 8257,2 : X = USR(X) : LIST (POKE 574,0 : POKE 575,224 : X = USR(X) : LIST)

The recorder is then set to record and started. Only then is the (carriage) return given. The whole program is then saved on the tape in Basicode form. After the computer gives the 'OK' signal the recorder can be stopped. It is also possible to save only a part of the program on tape (for example, lines 1000-1090):

POKE 8256,0 : POKE 8257,2 : X = USR(X) : LIST 1000-1090 (POKE 574,0 : POKE 575,224 : X = USR(X) : LIST 1000-1090).

Before the BASIC program is stored on tape, the computer 'translates' the program first into 'LIST' format and places that in a table which appears above the BASIC program in the RAM range. With large programs, the RAM range may not be big enough to store both of these so after the program is stored on tape the computer returns the 'NEW' message. This means that the original BASIC program is erased from the memory. As it is in Basicode form on the tape anyway, it can also be read in again.

Details of the translation program

This next section is a description of the write and read routines (more details are given in the listing of table 1).

The write program

When this routine is called with means of X = USR(X), the OUTPUT vector (of the BASIC Junior) is changed for the start address of a machine code routine (TABLE in the write program). This routine stores an ASCII character from ACCU into RAM. After giving a LOKE command (with POKE . . . : POKE . . . : X = USR(X) : LIST), the computer will list the program on the screen (or on the printer). Because the OUTPUT vector is changed (it normally points to the 'print character' routine), the TABLE routine is used to store the listing in RAM above the original BASIC program. The program is then stored in this table in LIST format.

After the BASIC Junior notes the end of the program and is therefore finished listing, it jumps via the JMP command at addresses 0003 . . . 0005 to SVECAS. This routine sets the whole table onto cassette with 1200 and 2400 Hz tones. When that is done the OUTPUT vector and the JMP at address 0003 are reset and the computer returns to BASIC.

The read program

After this program is called by X = USR(X), the Basicode program is read from cassette and stored in the form of a table in RAM. Again the program is in LIST format. When the 'end of text' character and the checksum are read in, the whole program is located in this table, the INPUT vector (in the BASIC Junior) is changed for the start address of the LDIND routine, and the computer returns to normal BASIC.

The computer should now really wait for an input from the terminal (the INPUT vector normally points to the receive character routine), but because the INPUT vector points to the LDIND routine the characters are called one by one from the table by the BASIC Junior (and printed at the same time). This makes it seem as if a program is being typed in at high speed. The program thus read out of the table is then processed and stored in the normal way. Finally, the INPUT vector is reset and the computer returns with 'OK'. The user can then work with the program as usual.

BASIC subroutines

Apart from the translation program there is also a need for some subroutines, written in Basicode-2 protocol. These are dealt with in depth in the descriptive article, 'Basicode-2', in this issue.

Three of these subroutines are not usable with the Junior/Elekterminal combination. These are routines 120, 200 and 250. Subroutine 120 relates to the position of the cursor on the screen and subroutine 200 checks whether at a specific moment a key is pressed. Neither is possible because of the arrangement of the Elekterminal. Subroutine 250 just gives a bleep, but the Elekterminal is mute.

If the main BASIC program calls subroutine 120 or 250 nothing happens because in the Junior these subroutines consist of the 'RETURN' command. For subroutine 200 IN\$ is an empty string so that it seems as if no key is pressed at that moment.

The standard subroutines for the expanded Junior and the DOS Junior, both with the Elekterminal, are given in tables 4 and 5 respectively. Subroutines 350 and 360 should really refer to a printer but in our case they refer to the terminal.

The subroutines can be read in either before or after the Basicode program. That makes no difference as long as they are present when the program is RUN. If, for example, the Basicode program has already been read in, the subroutines can simply be added by reading them in using POKE . . . : POKE . . . : X =USR(X).

Two program sections can be added to form one program by reading them both in separately. The only prerequisite is that the two parts have no identical line numbers.

Practical points

After reading in a Basicode programme it is only common sense to check it through carefully. Often there are some details that have a different meaning on your computer to what they meant to the computer on which the program was developed. This is a common reason for programs not to work.

Consider this case, for example: we have a Basicode program that draws a maze, and it contains the necessary PRINT statements. If part of the maze is now drawn on the screen and the program wants to PRINT something in the middle of the maze, a carriage return and line feed are automatically generated after the print statement. With the Elekterminal a carriage return

Table 4

```

LIST
10 GOTO 1000
20 GOTO 1010
100 PRINT
101 POKE6745,200:PRINT CHR$(12);
102 POKE6745,3
103 RETURN
110 IF NO=63 THEN RETURN
111 IF VE=15 THEN RETURN
112 POKE6745,200:PRINT CHR$(20);
113 POKE6745,3
114 PRINT
115 IF NO=0 GOTO 117
116 FOR OD=1 TO HO:PRINT CHR$(9);:NEXT
117 FOR OF=-1 TO 15-VE:PRINT CHR$(11);:NEXT
118 RETURN
120 RETURN
200 IN$="":RETURN
210 OS=PEEK(8256):OT=PEEK(8257)
211 POKER256,(10*16+14):POKER257,(1*16+2)
212 O=USR(O)
213 POKER256,OS:POKER257,OT
214 OX=(PEEK(6754) AND 127)
215 IN$=CHR$(OX)
216 RETURN
250 RETURN
260 RV=RND(1):RETURN
270 FR=PRE(0):RETURN
300 IF SR<0 AND SR>=-01 THEN SR=0
301 IF SCN(SR)=1 THEN SR=STR$(SR):RETURN
302 SR=MID$(STR$(SR),2):RETURN
310 OS=ABS(SR)*.5*10^-CN:OI=INT(OS):OD=OS-OI+1
311 SR$=""
312 IF OD=1E9 THEN 321
313 IF CN=0 THEN ODS="":GOTO 317
314 IF OD=1 THEN ODS="":GOTO 316
315 ODS=MID$(STR$(OD),3,CN+1)
316 IF LEN(ODS)<CN+1 THEN ODS=ODS+"0":GOTO 316
317 SR$=MID$(STR$(OI),2)+ODS
318 IF SR<0 AND VAL(SR$)<0 THEN SR$="-"+SR$
319 IF LEN(SR$)<CT THEN SR$=" "+SR$:GOTO 319
320 IF LEN(SR$)>CT THEN SR$=""
321 IF LEN(SR$)<CT THEN SR$=SR$+"":GOTO 321
322 RETURN
350 PRINT SR$:RETURN
360 PRINT :RETURN
OK

```

Basicode-2 interface for the Junior Computer
elektor oktober 1983

Table 4. The standard subroutines for the expanded Junior with KB-9-BASIC.

Table 5

```

LIST
10 GOTO 1000
20 GOTO 1010
100 PRINT
101 POKE64089,200:PRINT CHR$(12);
102 POKE64089,3
103 RETURN
110 IF NO=63 THEN RETURN
111 IF VE=15 THEN RETURN
112 POKE64089,200:PRINT CHR$(20);
113 POKE64089,3
114 PRINT
115 IF NO=0 GOTO 117
116 FOR OD=1 TO HO:PRINT CHR$(9);:NEXT
117 FOR OF=-1 TO 15-VE:PRINT CHR$(11);:NEXT
118 RETURN
120 RETURN
200 IN$="":RETURN
210 OS=PEEK(574):OT=PEEK(575)
211 POKER574,(1*16+11):POKER575,(15*16+14)
212 O=USR(O)
213 POKER574,OS:POKER575,OT
214 OX=PEEK(9059)
215 IN$=CHR$(OX)
216 RETURN
250 RETURN
260 RV=RND(1):RETURN
270 FR=PRE(0):RETURN
300 IF SR<0 AND SR>=-01 THEN SR=0
301 IF SCN(SR)=1 THEN SR=STR$(SR):RETURN
302 SR=MID$(STR$(SR),2):RETURN
310 OS=ABS(SR)*.5*10^-CN:OI=INT(OS):OD=OS-OI+1
311 SR$=""
312 IF OD=1E9 THEN 321
313 IF CN=0 THEN ODS="":GOTO 317
314 IF OD=1 THEN ODS="":GOTO 316
315 ODS=MID$(STR$(OD),3,CN+1)
316 IF LEN(ODS)<CN+1 THEN ODS=ODS+"0":GOTO 316
317 SR$=MID$(STR$(OI),2)+ODS
318 IF SR<0 AND VAL(SR$)<0 THEN SR$="-"+SR$
319 IF LEN(SR$)<CT THEN SR$=" "+SR$:GOTO 319
320 IF LEN(SR$)>CT THEN SR$=""
321 IF LEN(SR$)<CT THEN SR$=SR$+"":GOTO 321
322 RETURN
350 PRINT SR$:RETURN
360 PRINT :RETURN
OK

```

Table 5. The standard subroutines for the DOS Junior.

Figure 1. The circuit diagram for the interface circuit that must be connected between a cassette recorder and the Junior Computer.

Parts list

Resistors:

- R1 = 4k7
- R2,R4,R7 = 1 k
- R3 = 10 k
- R5 = 1 M
- R6 = 56 k
- P1 = 25 k preset

Capacitors:

- C1 = 220 n
- C2 = 10 µ/10 V
- C3 = 56 n
- C4 = 100 n

Semiconductors:

- IC1 = 3140

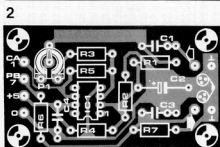
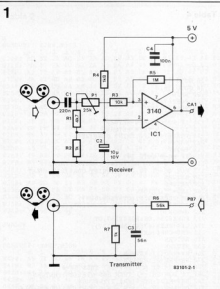
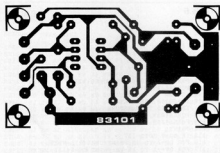

Figure 2. The printed circuit board layout for the interface circuit.

Figure 3. This shows the wiring layout that must be used if both the normal Junior cassette interface and the Basicode interface are to be used together.



means that everything after the print statement on this line is erased. In this example the program can easily be adapted by following the PRINTs in question with a ;. The CR and LF are not produced then and the program runs properly.

A program could, of course, also call a subroutine that the Junior/Elekterminal does not recognize (120, 200 and 250). Subroutines 200 and 250 are no real problem and can easily be avoided, but it is sometimes more difficult to do without routine 120. If sub 120 is used, for example, in a game to define the position of the cursor on the screen, it can be very difficult to adapt the program. Subroutine 120 is also quite often used to define the screen size. This can also be done by leaving out the appropriate lines and stating on the free lines how large the screen is (16 lines of 64 characters on the Elekterminal). In the case where, for example, the screen format is defined for a section of a program, and after leaving this section, variables VV and HH must contain the height and width of the screen. In our case this program section is simply changed by VV = 15 : HH = 63 (remember that the first position has always number zero).

A final note about the @ sign in KB-9-BASIC. If the computer sees this sign the whole line is erased and CR and LF are given.

The hardware

The hardware for the Basicode interface consists of a small adapter circuit which is connected between the cassette recorder and the Junior Computer. The circuit diagram is shown in figure 1. It consists of a transmitter and a receiver section. The receiver contains only one IC (3140) which is connected as a schmitt trigger/level adapter. Using P1, the trigger level can be set between certain limits, but normally the circuit works correctly if the pot is roughly in mid position. The transmitter section simply reduces the output signal from the Junior and filters out the higher harmonics from the signal.

The printed circuit board for the interface (figure 2) is designed so that two phono plugs (for input and output) can be soldered directly onto the board using some wire links. Points CA1 and PB7 are connected to the corresponding points on the VIA connector on the interface board.

If the normal Junior cassette interface and the Basicode interface are to be connected at the same time (the former is needed to read in machine code programs), care must be taken when wiring the interfaces. The wiring diagram for connecting both interfaces is given in figure 3. Any deviation from this layout is likely to result in earth losses occurring and the possibility of oscillation is greater. This same diagram also shows a block called signal cleaner! This circuit, which is also described in this issue, is only needed if the signal from the recorder (or radio) is of very poor quality. It is easy to try without this interface first and if this does not work, the circuit could always be added.

3

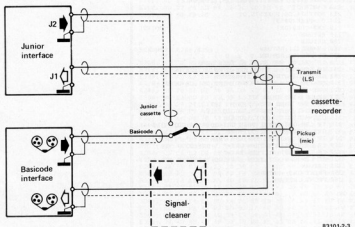

83101-2-3

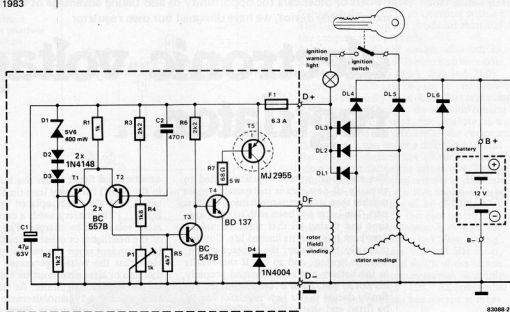

Figure 2. The circuit of the electronic voltage regulator. To clarify the set-up, the alternator, battery, ignition switch, and ignition warning light have been included.

pattern may vary from vehicle to vehicle. The output from the alternator is smoothed to an acceptable level. Diodes D2 and D3 and zener D1 provide a reference voltage of 6.9 V. Transistors T1...T3 form a differential amplifier, with the base of T1 functioning as the inverting input and the base of T2 as the non-inverting input. The collector of T3 is the output. As soon as the ignition is switched on, a current flows from the battery to the base of T4 via the ignition warning light and resistor R6. Transistor T4 conducts and drives T5, which ensures that a current flows through the rotor winding via terminal Df.

When the engine starts, the alternator will produce some output. Once the engine speed reaches about 1500 RPM, the stator windings generate a rapidly rising voltage. Because of the constant voltage across D1...D3, the base potential of T1 will rise in unison with the alternator output. However, because of the voltage divider R3, R4, P1, the base voltage of T2 will rise less rapidly. Consequently, the base of T1 will become more positive than that of T2, so that the latter conducts harder. The consequent base voltage applied to T3 causes this transistor to conduct also and this in turn makes the base potential of T4 fall. The rotor current, and therefore the alternator output, decreases and causes the base potential of T2 to rise above that of T1. Transistor T2, and therefore T3, conducts less which makes T4 and T5 conduct harder. This results in an increase in rotor current and, consequently, alternator output. The base of T2 will then become less positive than that of T1 and

Capacitor C2 serves as a by-pass for any noise emanating from the car's electrical system. Diode D4 short-circuits the back-e.m.f. induced in the rotor winding at the moment the ignition is switched off. In the introduction it was stated that new cars are invariably fitted with an electronic voltage regulator. This regulator is normally built into the alternator housing which has, of course, advantages, but also a disadvantage: if the regulator goes faulty, you invariably will have to buy a complete new alternator. This expense you will not have with the one described in this article.

Construction and calibration

All components of the regulator are fitted on the printed circuit board shown in figure 3. Note, however, that transistor T5 must be provided with a suitable heatsink. Some care is required when adjusting the circuit for use: calibration must be carried out before the regulator is fitted in the car. You need a high-performance (preferably digital) voltmeter, preferably two independent power supplies, and an ordinary 12 V/18 W car bulb.

The set-up for the calibration is shown in figure 4. Power supply 1 should be able to deliver at least 100 mA with a variable, stabilized output voltage of between 0 V and 15 V. Supply 2 represents the load (battery and car electrics) and should provide 12 V at 1.5 A. It could, of course, be replaced by a well-charged car battery. The calibration should be carried out at an ambient temperature of about 20°C. Once everything has been arranged as shown in figure 4, set supply 1 to its lowest output voltage and then increase the output slowly,

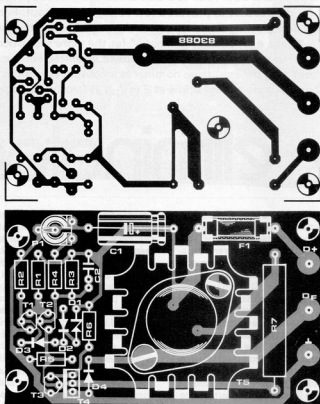

electronic voltage
regulator ...
elektor october 1983

Part list

Resistors:

R1 = 1 k
R2 = 1k2
R3, R6 = 2k2
R4 = 1k8
R5 = 4k7
R7 = 68 Ω/9 W

Capacitors:

C1 = 47 μ/63 V,
electrolytic
C2 = 470 n

Semiconductors:

T1, T2 = BC 557B
T3 = BC 547B
T4 = BD 137/139
T5 = MJ 2955
D1 = zener diode 5V6/
400 mW
D2, D3 = 1N4148
D4 = 1N4004

Miscellaneous:

F1 = fuse 6.3 A,
delayed action
Heatsink for T5:
45 x 45 x 25 mm

Figure 3. The printed
circuit board for the
regulator.

watching the reading on the digital voltmeter (the reading on the built-in voltmeter of the supply is of no use here). When the voltmeter reads 3...5 V, the lamp should light. When the voltage is increased further, the lamp will burn brighter and brighter, but extinguish when 14.3 V is reached. This 'turn-over' voltage is set by P1 on the regulator. It is advisable to repeat this procedure by first lowering and then increasing the voltage again.

Once P1 has been set, gradually reduce the output of supply 1 from 15 V. When 13.9...14.0 V is reached, the lamp should light again. The hysteresis of about 0.3 V is largely dependent upon R3.

Fitting the regulator in the car should generally not present a problem: the three terminals on the printed circuit board are designated as per DIN-norm which is also used by most car (and generator) manufacturers. None the less, if the terminals on the dynamo/alternator in your car are not marked D+, D-, and DF, it should not be very difficult to determine the correct connections (to which the existing regulator is, of course, fitted). ■

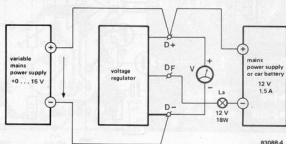

Figure 4. Before the
regulator is fitted in the
car, it must be very care-
fully calibrated. This
figure shows how the regu-
lator and test equipment
should be set up.

Battery eliminator or mains adapter? The names can be confusing as they're interchangeable freely and both refer to a unit which plugs directly into a standard 13 A mains socket to provide a low-voltage d.c. output. Fortunately, there seems to be a growing tendency to use the name 'mains adapter' for unregulated supplies, and 'battery eliminator' for the more sophisticated, stabilized ones. The unit presented here provides a stabilized voltage which is variable about ± 25 per cent from nominal at an output current of 250 . . . 300 mA. Ripple voltage is low at 2 mV_{pp} at maximum output.

battery eliminator

stabilized,
variable-
voltage power
supply

It is not too difficult to convert a bought-out mains adapter to a battery eliminator by simply adding a voltage regulator. As, however, the results were not very satisfactory, we decided to start from scratch and also provide current limiting.

The unit is built in a small standard case which is connected to the mains by a short lead, resulting in a neat, practical unit. The output voltage range is determined by a fixed voltage divider, the precise output voltage by a preset. We have intentionally designed the unit around common components which virtually every electronics hobbyist is likely to have lying around. A 78XX regulator IC could, of course, have been used, but this might have meant purchasing one to many of you. Our design offers you the chance to make use of some of those components which have been lying idle for too long.

The circuit diagram

Transistors T1 and T2 form the current limiter which will be described later. The 'work horse' of the circuit - see figure 1 - is T3, a high-power, low-frequency transistor type BD 139. Its base is driven by a voltage regulator formed by a standard 741 opamp

(IC1). The supply for the regulator is taken directly from C1+ to ensure that regulation can take place over the largest possible range. Capacitor C3 is included to provide further stabilization of the output voltage. We now come to the heart of the matter: the voltage regulation. Voltage divider R4-D6 provides a stable reference voltage which is applied to the non-inverting input of the 741. The wiper of preset P1 is connected to the inverting input. If the output voltage rises, the potential at the inverting input also rises via the voltage divider consisting of R5, P1, and R6. The output of IC1 then becomes more negative and the current through T3 decreases. When the output voltage drops, for instance, because of a higher load, the reference voltage at pin 3 of the 741 is higher than that at pin 2. The output of the opamp becomes more positive and the current through T3 increases. In both cases, a new, stable equilibrium is reached quickly between the output voltage of the circuit as a whole and that of IC1.

This does not take the current limiter into consideration. If the voltage across R2, the current sensor, exceeds 0.6 . . . 0.7 V, T1 conducts. A current then flows from the output of IC1 to earth via R1 and the collector-emitter junction of T1. Transistor

Figure 1. The circuit diagram of the battery eliminator which provides both voltage stabilization and current limiting at a reasonable cost.

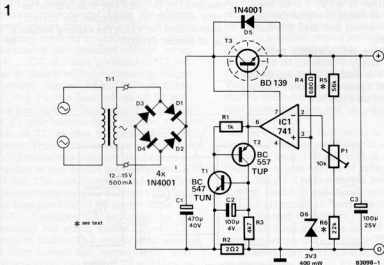

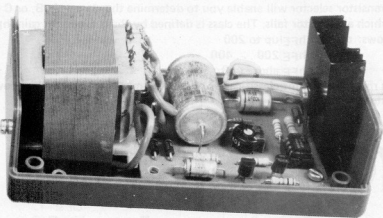

T2, a p-n-p type, conducts because its base, due to the voltage drop across R1, is more negative than its emitter. A further current flows therefore into the base of T1 from the collector of T2 and both transistors continue conducting. That is the reason why this particular limiter has been called 'pseudo thyristor'.

What happens to T3 in this case? As its base current - which flows to earth via the pseudo thyristor - is pinched off, it changes state and the output voltage drops to zero. The output current of IC1 then becomes small and the current-limiter transistors remain in the conducting state. The eliminator is therefore adequately protected against overload and short-circuit conditions. To be sure, this simple circuit has neither an indicator to show that the current limiter has come into operation nor a reset to switch off this protection device. Therefore, if the output voltage 'dies', you have to pull the plug from the mains socket and reinsert it to make the eliminator operational again. The current limiter also provides protection against thermal overload, because the base-emitter voltage at which T1 starts to conduct decreases with rising temperature ($U_{BE} = -2 \text{ mV}/^{\circ}\text{C}$). This means that the limiter may also come into operation if

at relatively high current the temperature inside the housing rises.

Table 1

secondary voltage	R5 (k Ω)	P1 (k Ω)	R6 (k Ω)	Output voltage range (V)	
				calculated	measured
10	15	10	22	4.8 ... 7.0	4.3 ... 6.7
12	22	10	15	6.2 ... 10.3	6.0 ... 10.6
15	56	10	22	9.1 ... 13.2	9.0 ... 14.6

All measurements at $I_{out} = 250 \text{ mA}$

Construction

As most of the components are mounted on a printed circuit board, construction is fairly simple. We have not made provision on the board for the transformer, so that the choice of this item remains reasonably flexible. Preset P1 can be replaced by a potentiometer to enable external adjustment of the output voltage.

Table 1 gives the values for R5, R6 and P1 for various transformer secondary voltages, and the corresponding output voltage ranges (both calculated and measured on our prototype). The maximum output current is about 250 ... 300 mA but somewhat lower with rising temperatures as explained before.

Table 1. The resistance values given here cover a total range of 4.3 ... 14.6 V which should meet most demands.

Parts list

Resistors:

- R1 = 1 k
- R2 = 2 Ω , 0.5 W
- R3 = 4k7
- R4 = 680 Ω
- R5 = 56 k see table 1
- R6 = 22 k
- P1 = preset 10 k linear

Capacitors:

- (all electrolytic)
- C1 = 470 μ /40 V
- C2 = 100 μ /4 V
- C3 = 100 μ /25 V

Semiconductors:

- T1 = BC547
- T2 = BC557
- T3 = BD139
- D1 ... D5 = 1N4001
- D6 = zener diode 3V3, 400 mW
- IC1 = 741

Miscellaneous:

- Heat sink for T3: about 37 mm high, 8.6 $^{\circ}$ C/W
- Mains transformer: secondary 10 ... 15 V/500 mA
- Case, plastic 120 x 65 x 65 mm

2

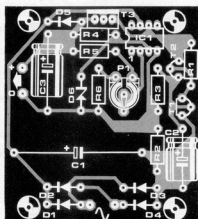
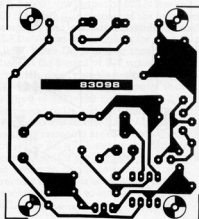

Figure 2. The printed circuit board of the battery eliminator is designed to receive all components, except the mains transformer. The mirror image of the track layout is contained in the PC pages.

This transistor selector will enable you to determine the class – A, B, or C – into which a transistor falls. The class is defined by the d.c. current gain, h_{FE} , as follows: class A: h_{FE} up to 200
 class B: h_{FE} 200 . . . 400
 class C: h_{FE} above 400

This is roughly the same classification as used by manufacturers on low-power transistors.

transistor selector

The classification A, B, or C, given by manufacturers in their data books does not always indicate exact values. Normally, the three classes are given minimum, maximum, and typical values, and therefore they overlap to some extent. It may sometimes be necessary to check the class printed on the transistor. Or it may be that you want to find a replacement in the 2N . . . series for a BC . . . type with an equivalent d.c. current gain. In such cases you will find this selector a very useful tool.

The circuit diagrams

The selector can, of course, be used for both n-p-n and p-n-p transistors. For clarity, we have split the complete circuit diagram shown in figure 3 into two parts: figure 1 for n-p-n transistors and figure 2 for p-n-p types.

n-p-n transistors

If a PP3 battery is used as power supply, the base current in the transistor under test amounts to about $10 \mu A$. The collector voltage is then given by
 $U_C = U_b - U_{R2} = U_b - I_C R_2 = U_b - h_{FE} I_B R_2$

where U_C = d.c. collector voltage
 U_b = supply voltage = 9 V
 U_{R2} = voltage drop across resistor R_2
 I_C = d.c. collector current
 I_B = d.c. base current = $10 \mu A$
 h_{FE} = d.c. current gain

Substituting the known values into this formula, we obtain:

$U_C = 9 - 0.015 h_{FE}$ volts
 If we now substitute the 'turn over' values

Figure 1. The circuit for checking n-p-n transistors. The coding of the LEDs corresponds to the usual classification of the d.c. current gain.

Figure 2. Compared with figure 1, the circuit for p-n-p transistors appears up-ended. The differences between the two are explained in the text.

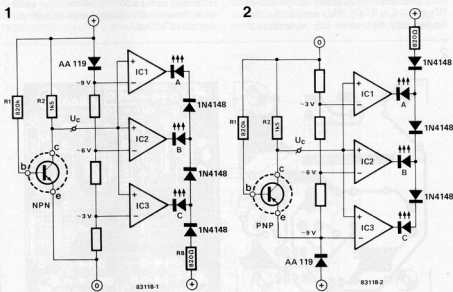

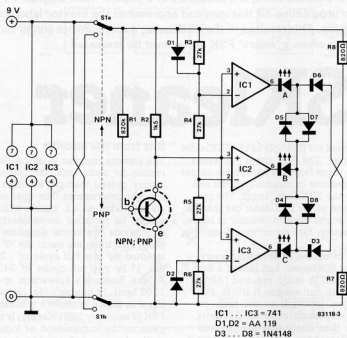

Figure 3. Combining the circuits of figures 1 and 2 yields that for the complete transistor selector. The only addition is switch S1.

of h_{FE} , we obtain values for U_C of 6 V when $h_{FE} = 200$ and 3 V when $h_{FE} = 400$. In other words, the greater the d.c. current gain, the smaller the collector voltage. A moment's reflection will show why: the greater the d.c. current gain, the greater the collector current and resulting voltage drop across R2, and the smaller the voltage across the collector-emitter junction of the transistor being checked.

The collector voltage is applied to the non-inverting inputs of three comparators: opamps IC1 ... IC3. The inverting inputs of these opamps are derived from a voltage divider, R4 ... R6, across the supply voltage (R3 is, of course, short-circuited by diode D1). When U_C is smaller than 3 V ($h_{FE} > 400$), the output of IC3 is low and LED 'C' lights. The outputs of the other two opamps are also low, but the anode voltage of LEDs 'A' and 'B' is too low for the LEDs to light. When U_C is greater than 3 V, the voltage at the output of IC3 is nearly 9 V. No current then flows through LED 'C' and LED 'B' lights. When U_C is greater than 6 V ($h_{FE} < 200$), the output of IC2 is nearly equal to U_b and only the output of IC1 remains low so that LED 'A' lights. The above reasoning depends upon a voltage drop across R8 which ensures just sufficient anode voltage for the lighted LED. It may be that owing to circuit tolerances in your particular case this is not entirely possible: the solution is then to increase R8 to, say, 1 k Ω .

p-n-p transistors is shown in figure 2. The arrangement of the LEDs for classes A, B, and C, remains as before. Now, however, because the supply voltage polarity has been reversed, a higher d.c. current gain will cause a higher collector voltage. The voltage applied to the comparators is, therefore, in this case not that across the collector-emitter junction, but that across R2. Otherwise the operation of the circuit is identical to that for n-p-n transistors.

The complete circuit ...

... is not so difficult to follow now. The sections for n-p-n and p-n-p transistors have been combined. The polarity of the supply voltage is reversed by means of a double-pole switch, S1. Diodes D1 ... D3 and D4 ... D6 ensure that the circuit operates satisfactorily whatever the position of S1. We have used germanium diodes in the D1 and D2 positions, as these have a smaller voltage drop than silicon types. The selector may be constructed on a piece of VERO or other prototyping board: it is not critical. This board may then be fitted in a small case, together with the battery. The case should, of course, be provided with three connecting clips for the transistor to be checked.

p-n-p transistors

The corresponding diagram for selecting

Although a cassette recorder remains one of the best value-for-money systems available, an audio cassette is a far from ideal memory for computers. Like many others before them, the producers of a popular West German TV computer programme hit this snag and approached the Elektor laboratories for a solution. This resulted in the FSKleaner, a useful device for all applications where a 'messy' FSK signal must be processed.

FSKleaner

cosmetics for FSK signals

Basicode is a standard audio code which enables BASIC programs written on one micro-computer to be used on another, provided this has a Basicode interface. It is transmitted as a TV or radio signal.

Programs are broadcast (at the time of going to press) every Sunday from 17.10... 17.45 GMT (summers) or 18.10... 18.45 GMT (winters) on 747 kHz by NOS (Nederlandse Omroep Stichting = Dutch Broadcasting Foundation)

Photo 1. Example of an FSK signal in Basicode. At the top: the distorted signal. At the bottom: the output signal of the FSKleaner. Coordinates: horizontal 500 μ s/division; vertical - top - 100 mV/division, bottom 2 V/division.

Photo 2. The operation of the compressor is shown very clearly. The amplitude of the 1800 Hz input signal increases with time (top). The compressor controls the input to the final amplifier so that the output of the FSKleaner is nearly constant (bottom). Coordinates: top and bottom, 2 V/division (vertical), 1 s/division (horizontal).

Figure 1 shows the principle of the FSKleaner in block form. The FSK signal containing the data is taken from the headphone output of a radio receiver or cassette recorder and applied to the FSKleaner input. The processed output of the FSKleaner can then be fed into a second cassette recorder or loaded into a computer directly or via a Basicode interface.

You may, of course, at first sight query whether an FSKleaner, and indeed a Basicode interface, is really required. All we can say is: 'In our opinion it is!' If, for instance, you record from the radio or from the umpteenth copy of a cassette, it is more than likely that the received data are affected by white noise. The signal then looks something like that shown in photo 1 (top) or even worse. Our FSKleaner will, in these cases, ensure a 'clean' signal as shown in photo 1 (bottom).

Another problem is the varying level of the FSK signal. We have assumed that the output of the radio receiver or recorder, depending upon the setting of the volume control, may vary between 450 mV_{eff} and 4 V_{eff}. The level of the FSK signal must, of course, be sufficient to be compatible with the input requirements of the computer. Both problems are taken care of in the FSKleaner: a band-pass filter removes most of the white noise, while a compressor ensures that the output remains reasonably constant for variations in input level of about 20 dB.

Yet other problems may arise, however: if the FSK signal output of the FSKleaner is still not 100 per cent compatible with the computer, a Basicode interface (see article elsewhere in this issue) between the FSKleaner and the computer will put matters right.

Bits from the recorder

The cassette recorder is, and is likely to remain for some time, the best-value-for-money general memory available to the amateur programmer. The ones and zeros are converted to a.f. signals which can readily be recorded on magnetic tape. In Basicode (see article elsewhere in this issue) two tones are used: the '0' is represented by one full cycle of 1200 Hz, the '1' by two full cycles of 2400 Hz. At the Basicode's conversion speed of 1200 baud (= bits/sec), for instance, a signal as shown in photo 1 is obtained. FSK (Frequency Shift Keying) is the name given to the transmission of logic information by means of switching between two distinct, different frequencies representing the zeros and ones respectively. Unfortunately, neither the 'logic' frequencies nor the baud rate have been standardized, so that this information has to be gleaned from your own computer handbook. This is of little consequence here as we merely want to explain what the FSK signal is all about.

The circuit (figure 2)

The input resistance of the FSKleaner is determined by resistor R2. A low value has been chosen for this component to ensure good matching with a low-ohmic headphone output. Then follows a band-pass filter, L1... L3/C1... C5, which has an insertion loss of about 6 dB. The signal is then applied to amplifier A1 which has an amplification of some 40 dB, sufficient to raise even small signals to an acceptable level. In case the output of A1 is too high, it can be attenuated by preset P1 to match the input level requirement of the computer

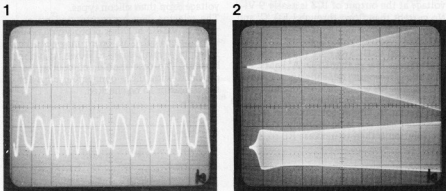

1

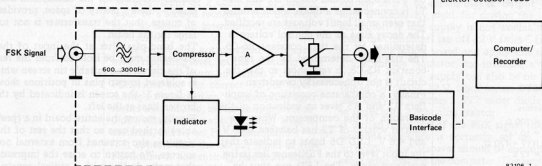
cosmetics for FSK signals
elektor october 1983

83106 1

2

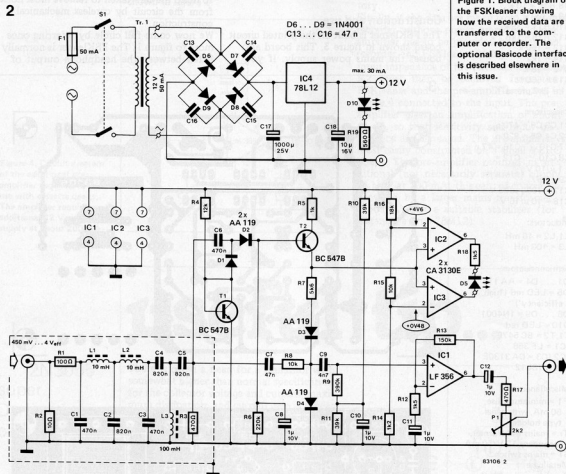

83106 2

or cassette recorder. The non-inverting (+) input of A1 is biased by R9/R11/C10, so that an asymmetrical 12 V power supply will suffice. So much for the direct signal path.

The compressor

A vital part of the circuit is formed by the compressor which, in a manner of speaking, indirectly passes part of the signal and yet affects it directly. How? This can be seen from photo 2: the triangle at the top shows a sinusoidal 1800 Hz tone the amplitude of which increases gradually with time. The effect of the compressor can be seen at the

bottom of photo 2: above a certain level of input signal, the compressor ensures that the output of the FSKleaner remains virtually constant.

The input to the compressor section is taken from across R3 via C6 to diode D2 where it is rectified. In this way a control voltage is obtained for transistor T2. The collector current of T2, and consequently the and D4 to earth, is therefore dependent upon the signal strength. The higher the current, the smaller the impedance of the input voltage to A1. Simple but effective!

Figure 1. Block diagram of the FSKleaner showing how the received data are transferred to the computer or recorder. The optional Basicode interface is described elsewhere in this issue.

Figure 2. The circuit diagram of the FSKleaner consists essentially of a band-pass filter, compressor and indicator stage, and output amplifier A1. When the input level lies between 0.45 and 4.0 V, an LED, D5, lights to indicate that the FSKleaner output is fully compatible with the input requirements of the computer.

Parts list

Resistors:

R1 = 100 Ω
R2 = 10 Ω
R3, R17 = 470 Ω
R4 = 12 k
R5 = 1 k
R6 = 220 k
R7 = 5k6
R8, R15 = 10 k
R9 = 390 k
R10, R11 = 39 k
R12, R18 = 1k5
R13 = 150 k
R14 = 1k2
R16 = 18 k
R19 = 560 Ω
P1 = 2k2 preset

Capacitors:

C1, C3, C6 = 470 n
C2, C4, C5 = 820 n
C7, C13 ... C16 = 47 n
C8, C10 ... C12 =
1 μ /10 V
C9 = 4n7
C17 = 1000 μ /25 V
C18 = 10 μ /16 V

Inductors:

L1, L2 = 10 mH
L3 = 100 mH

Semiconductors:

D1 ... D4 = AA 119
D5 = LED red ('high
efficiency')
D6 ... D9 = 1N4001
D10 = LED red
T1, T2 = BC 547B
IC1 = LF 356
IC2, IC3 = CA 3130E
IC4 = 78L12

Miscellaneous:

F1 = miniature fuse,
50 mA, with panel
type holder
Tr = mains transformer,
secondary 12 V/50 mA
S1 = mains switch
Metal case
Panel type input and
output terminals

Figure 3. Layout and track pattern of the printed circuit board for the FSKleaner. The band-pass filter is screened with a thin housing of tin. The connections to and from the mains transformer must be wired at the foil side of the board.

The voltage developed across R4 and transistor T1 is used to bias diodes D1 and D2. T1 is connected as a diode which ensures that even small input voltages are rectified. The decay time of the control voltage is determined by the time constant R6-C8. The rise time, determined by the time constant R3-C8, is very short so that the circuit is not unnecessarily overdriven. Finally, a comparator consisting of amplifiers A2 and A3 gives an indication of the operation of the compressor. When the emitter voltage of T2 lies between 0.48 V and 4.6 V, LED D5 lights to indicate that the input level to the FSKleaner lies in the preferred range. The LED can thus be considered an 'all systems go' indicator.

Construction and use

The FSKleaner is built on the printed circuit board shown in figure 3. This board also houses the mains power supply. If you

don't have a transformer with correctly spaced terminals for the board, drill new holes - there's plenty of space, provided, of course, that the transformer is not too large for the board.

The band-pass filter at the input of the FSKleaner must be isolated from the rest of the circuit by a suitable tin screen which is soldered to two pins in positions shown in figure 3: the screen is indicated by the broken lines at the left.

Finally, mount the entire board in a (preferably) earthed case so that the rest of the circuit is also screened from external noise sources. We hasten to erase the impression that we're dealing with a critical construction: we merely feel that it would be a pity to undo the care taken to remove most noise from the circuit by careless mechanical construction.

We now come full circle by referring once more to figure 1. The FSKleaner is normally fitted between the headphone output of

3

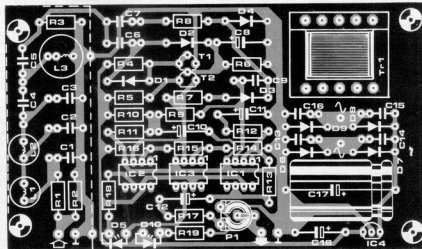
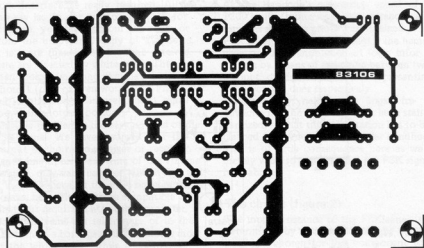

a radio receiver or tape recorder and the 'cassette' input of a computer or 'line' input of a second recorder. You therefore have to make up interconnecting cables as required.

If the recorder is not provided with automatic recording level, set the recording level control to maximum and adjust P1 on the FSKleaner for the correct output level during a test recording. If appropriate instruments are available, set the output level to 0 dB. Where automatic recording level is available, merely set P1 to maximum.

If it appears that the output signal of the FSKleaner is not entirely free from noise, a Basicode interface should be used between the FSKleaner and computer or recorder as shown in figure 1.

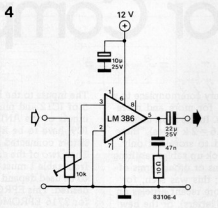

Figure 4. Circuit diagram of the additional pre-amplifier required for use with cassette decks. The amplifier requires an additional 12 V stabilized supply at about 200 mA.

The Basicode interface needs a supply voltage of 5 V to ensure that its output level is absolutely right for driving the computer. If this supply is not available from the computer, tap off 12 V from C18 on the FSKleaner board and apply this to a 5 V voltage regulator, for instance, a 78LS05. The 5 V supply can also be obtained by taking 12 V from across C18 and applying it across a 4V7 zener diode in series with a dropping resistor.

If during reception of the FSK signal the Basicode interface is correctly set up, no problems whatsoever should be encountered with loading the computer. The set-up was tested in our own computer laboratory for long periods and proved highly satisfactory.

Finally, if the data are taken from a cassette recorder without power amplifier, a pre-amplifier has to be provided between the recorder and FSKleaner owing to the low input impedance of the FSKleaner. Resistor R2 must then be removed from the FSKleaner and the pre-amplifier shown in figure 4 connected to the input. The pre-amplifier gives an amplification of about 26 dB, so that sensitivity and input impedance are increased. The pre-amplifier is most easily constructed on a small VERO board. The pre-amplifier requires an additional (not necessarily separate) supply of 12 V at 200 mA: this can, of course, be provided by a larger mains transformer (250 mA) and a suitable stabilizer (for instance, a type 78M12).

useful tip...

... 2N3055
 super
 Darlington
 pair

There is often a need for a transistor with somewhat higher than normal specifications for the collector voltage and current, maximum dissipation, and current gain. This can successfully be achieved by using a combination of complementary transistors connected to work as a single n-p-n or p-n-p transistor.

In the circuits shown here four transistors are used. By carefully choosing the values of R1, R3, and R4, the overall current gain will be of the order of one and a half million! The circuit characteristics are virtually the same as those of a 2N3055, so that a maximum of 115 W can be dissipated at 25°C, while the maximum collector voltage and current are 60 V and 15 A respectively. The saturation voltage of the n-p-n combination is about 2 V, that of the p-n-p combination around 3 V.

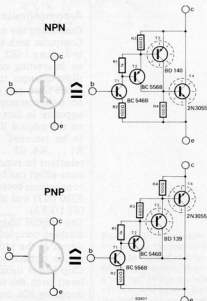

M. Seiler and
R. Kisse

programming
2716 EPROMs
with the
Junior
Computer

Many readers have asked in their letters how the main board of the Junior Computer can be used without an interface to program EPROMs, or how the JC can be used as a simple independent EPROMmer. Two readers, in particular, sent in a proposal about how this could be done, and, with their contributions, we reveal yet another facet of the 'Junior' Computer.

EPROMmer using the Junior Computer

It is now becoming very commonplace to see EPROMs being used for more and more different applications. In the most common current format (2716 = 2 k bytes), these components are used to store not only programs but also look-up tables resulting from code conversions or other forms of character generation; this was seen, for example, in some more recent articles on ator with lower case letters), or the new ASCII keyboard (code version), and, of course, there are many more examples. For really convenient use it is indispensable to have a programmer which makes it easy to transfer data stored in RAM into the EPROM.

A compromise

Combining the main board of the Junior Computer with the programmer published in January 1982, page 1-26, appears to offer an interesting compromise needing only slight changes to the address decoding. Apart from two extra resistors, there are no new components needed. Quite the opposite, in fact, some of the components on the original EPROM programmer have to be removed! Those in question are R1...R4, S3...S6 and IC5. If you are reluctant to remove this IC (74LS85), the same effect can be achieved by breaking the connections between its pin 6 and pin 5 of IC10 (N7) and also pins 2 and 12 of IC8 (FF1/FF2).

The original address decoding circuitry is disabled completely and replaced by the circuit at the top of figure 1. This combination of two logic gates supplies a single Chip Select signal (active with a high logic level) from the two input signals (K) produced by IC6 on the main board of the Junior Computer.

The inputs to the EXOR gate are pins 4 and 5 of IC12 and pin 6 is the output. Both inputs of the AND gate, pins 1 and 2 of IC9, have to be fitted with polarizing resistors connected to the positive supply. Then two of the eight possible connections from table 1 must be made; the actual ones to be used depend on the address decoding desired. This EPROMmer can only be used for 2716 EPROMs as programming 2732s is something quite different.

Figure 2 suggests how the two cards could be connected using two 64-pin female connectors. As this sketch indicates, it is strongly recommended that the connecting wires be insulated.

Any further information required in connection with this project can be found in the article mentioned before or in the Junior Computer books. **M**

Table 1

Address	Decoding	
0800 - 0FFF	K2-28c	K3-18c
0C00 - 13FF	K3-18c	K4-17a
1000 - 17FF	K4-17a	K5-15a
1400 - 1BFF	K5-15a	K6-15c

Table 1. Two K signals are needed to address a 2 k EPROM. The links used will depend on each individual user's requirements.

aplikator

A (re)new(ed) eight bitter: the 65C02

Even though it belongs to the same family, the 65C02 from Rockwell (and Synertek) is in some ways completely different to its older, popular brother, the 6502, which is used in many personal computers, our own Junior Computer among them. However the new IC is based on the old one and part of the reason why it is so long in coming is that the designers wanted not only to achieve some new features, but also to avoid losing any of the capabilities of the old chip. As yet none of these 65C02s have become available so we have not been able to experiment on further expanding the Junior but that is no reason not to describe the IC as we hope it will soon become available.

We will start by describing the most important characteristics of the 65C02 in brief.

One. The 65C02 is a CMOS chip. This means that the current consumption and the power dissipation are considerably less than in the case of the 6502. The reduction is from 575 mW (6502) to 20 mW (1 MHz version) power dissipation! In the 2 MHz version the dissipation doubles to 40 mW, while for the 3 and 4 MHz versions which will also be available the figures are 60 mW and 80 mW respectively. The minimum clock frequency is 100 kHz for the 6502 and 0 Hz for the 65C02 and, in this 'stand by mode', the 65C02 dissipates just 10 μ W. Other, CMOS related, advantages are the appropriately high tolerance in the supply voltage (5 V \pm 20% versus 5 V \pm 10%) and the improved noise margin (logic zero: 0.8 V instead of 0.4 V). Furthermore the inputs and outputs are still completely TTL compatible.

Two. There are versions (Rockwell: 65C102 and 65C112) with interesting signal connections for applications in systems requiring more than one microprocessor. If the BE (Bus Enable) input is made '0' the μ P is decoupled (three state) from the data bus, the address bus and the R/W line. It is therefore possible to use the related memory (temporarily) for another intelligent chip. However, DMA (Direct Memory Addressing) is undesirable while an instruction is being processed whereby memory is read, data is processed and rewritten (read-modify-write). These instructions are: ROR, ROL, ASL and LSR (with the

exception of accumulator addressing), DEC, INC, and the new instructions RMB, SMB, TRB, and TSB. While these instructions are being carried out the ML (Memory Lock) output is '0' and some gates could be used to make BE '0'.

Three. The reset input RES is equipped with a schmitt trigger. This makes it completely straightforward to use an RC network to automatically start a system with a 65C02 (power on reset). Another novelty is that the D flag is also reset when the reset instruction is used, so the CLD instruction occurs in the reset routine.

Up till now we have been describing the more important hardware orientated improvements. It is also good to see that, through improved 'bus management', the memory in the 2 MHz version can be 30 ns slower than in the case of the 6502 (maximum access time is 340 ns instead of 310 ns), but that is a software improvement, of course.

Four. All the software improvements are given in table 1, which has the same format as Appendix 2 of the Junior Computer book 1. This table shows that there are some new instructions, and thus new mnemonics, and there are also some existing instructions that can be carried out by more addressing modes (including some new ones).

Five. The INA and DEA instructions are a handy alternative for: CLC and ADCIM 01 (INA), and SEC and SBCIM 01 (DEA). There is also something similar for making a memory location 00. Formerly that was done with LDAMI

00 followed by STA; now all that is needed is STZ.

Six. The BRA instruction (BRanch Always) can be used instead of a JMP, as long as the jump is not too large. In relocatable programs we can do without (absolute) JMPs completely.

Seven. Suppose A, X and Y have to be saved on the stack at the beginning of a subroutine or interrupt routine. A look at table 2 will quickly show the advantages to be gained by enabling X and Y to be directly pulled and pushed. This saves both bytes and time.

Eight. A JMP (IND) instruction already existed, but now there is also a JMP (IND,X). The difference between both instructions is illustrated in figure 1. It sometimes happens that at a particular point in a program a choice has to be made from a number of jump addresses. Think of an assembler or disassembler, where the jump address is tied up with the addressing mode (thirteen possibilities for the 6502). Assuming the choice depends on the value of X, figure 1a shows everything that must happen in the case of the JMP (IND). First the operand address INAD of the JMP (IND) must be loaded (in RAM!) via X-indexed addressing from the 'jump table' TAB. Only then is the jump carried out. Comparing this with figure 1b shows that the indirect jump to TAB occurs immediately, based on the same value of X.

Nine. The instructions ADC, SBC, CMP, AND, OR, EOR, LDA and STA can now be executed in indirect addressing mode on condition that

PART NUMBER	DIP PINS	ADDRESSABLE MEMORY (BYTES)	ON BOARD CLOCK OSCILLATOR	SERIAL CLOCK FOR MEMORY ACCESS	ADVANCED MEMORY ACCESS
65C02-01	40	1K			
65C02-02	28	1K			
65C02-03	28	1K			
65C02-04	28	1K			
65C02-05	28	1K			
65C02-06	28	1K			
65C02-07	28	1K			
65C02-08	40	1K			
65C02-09	28	1K			
65C02-10	28	1K			
65C02-11	28	1K			
65C02-12	28	1K			
65C02-13	28	1K			
65C02-14	28	1K			
65C02-15	28	4K			
65C02-16	40	65K			
65C02-17	28	4K			
65C02-18	28	8K			
65C02-19	28	16K			
65C02-20	28	32K			
65C02-21	28	64K			
65C02-22	40	128K			
65C02-23	28	256K			

the operand address (= indirect address) lies in page zero. This means that no Y index ((IND), Y) is now needed to specify page 0 for an effective address.

Table 1

memonics and description	addressing mode(s)	hex opcode	number of clock pulses (N)	number of bytes	flags affected
ORA "OR" memory with accumulator A \cup M \rightarrow A	(IND) (5)	12	5	2	N---Z-
SBC subtract memory from accumulator with borrow A-M-C \rightarrow A (3)	(IND) (5)	F2	5 (4)	2	N---ZC
STA store accumulator in memory A \rightarrow M	(IND) (5)	92	5	2	-----
BIT test bits in memory: A \cap M M7 \rightarrow N; M6 \rightarrow V	IMM Z, X ABS, X	89 34 3C	2 4 4 (1)	2 2 3	M7M6---Z-
JMP jump to new location	(IND), X (6)	7C	6	3	-----
TRB test & reset memory bits with accumulator A \cap M \rightarrow M M7 \rightarrow N; M6 \rightarrow V	ABS Z	1C 14	6 5	3 2	M7M6---Z-
TSB test & set memory bits with accumulator A \cup M \rightarrow M M7 \rightarrow N; M6 \rightarrow V	ABS Z	0C 04	6 5	3 2	M7M6---Z-
BBR (7) (8) branch on: bit M0 = 0 (BBR0) bit M1 = 0 (BBR1) bit M2 = 0 (BBR2) bit M3 = 0 (BBR3) bit M4 = 0 (BBR4) bit M5 = 0 (BBR5) bit M6 = 0 (BBR6) bit M7 = 0 (BBR7)	Z & REL Z & REL Z & REL Z & REL Z & REL Z & REL Z & REL Z & REL	0F 1F 2F 3F 4F 5F 6F 7F	5 (2) 5 (2) 5 (2) 5 (2) 5 (2) 5 (2) 5 (2) 5 (2)	3 3 3 3 3 3 3 3	-----
BBS (7) (8) branch on: bit M0 = 1 (BBS0) bit M1 = 1 (BBS1) bit M2 = 1 (BBS2) bit M3 = 1 (BBS3) bit M4 = 1 (BBS4) bit M5 = 1 (BBS5) bit M6 = 1 (BBS6) bit M7 = 1 (BBS7)	Z & REL Z & REL Z & REL Z & REL Z & REL Z & REL Z & REL Z & REL	8F 9F AF BF CF DF EF FF	5 (2) 5 (2) 5 (2) 5 (2) 5 (2) 5 (2) 5 (2) 5 (2)	3 3 3 3 3 3 3 3	-----
RMB (7) reset memory bit: M0 (RMB0) M1 (RMB1) M2 (RMB2) M3 (RMB3) M4 (RMB4) M5 (RMB5) M6 (RMB6) M7 (RMB7)	Z Z Z Z Z Z Z Z	07 17 27 37 47 57 67 77	5 5 5 5 5 5 5 5	2 2 2 2 2 2 2 2	-----

Notes

- Add to N1 if a page size is exceeded.
- Add to N1 if the jump is to a location on the same page; add to N2 if the jump is to a location on another page.
- Borrow = not-carry (C).
- Add to N1 for decimal calculations. This applies also for existing addressing modes.
- (IND): for an address on page 0 in which the right hand byte consists of the effective address, the second byte = ADL; the left byte of the effective address is located in the next highest address on page 0.
- (IND,X): for the 16-bit number, formed from the second (L) and third (H) bytes of the instruction, the contents of the X register is summed. This sum is the address containing the right hand byte of the effective address; the left hand byte of the effective address is in the next highest address.
- Rockwell types R65C02, R65C102 and R65C112.
- First byte: opcode;
second byte: ADL of address on page 0;
third byte: offset.

Literature

Rockwell R 65C00 CMOS Microprocessor System data sheet.

Note: There is also a revised version with 'debugging'.

Synertek SY 65C00 CMOS 8-bit Microprocessor Family data sheet.

GTE data sheet G 65CXX series and G65SC1XX series

Junior Computer book 1.

SMB (7)					
set memory bit:					
M0 (SMB0)	Z	B7	5	2	
M1 (SMB1)	Z	97	5	2	
M2 (SMB2)	Z	A7	5	2	
M3 (SMB3)	Z	B7	5	2	
M4 (SMB4)	Z	C7	5	2	
M5 (SMB5)	Z	D7	5	2	
M6 (SMB6)	Z	E7	5	2	
M7 (SMB7)	Z	F7	5	2	
PHX push X-register on stack X↓ S-1→S	IMP	DA	3	1	
PHY push Y-register on stack Y↓ S-1→S	IMP	5A	3	1	
PLX pull X-register from stack X↑ S+1→S	IMP	FA	4	1	
PLY pull Y-register from stack Y↑ S+1→S	IMP	7A	4	1	
STZ store zero in memory 0→M	ABS Z Z, X ABS, X	9C 64 74 9E	4 3 4 5	3 2 2 3	
DEC (DEA) decrement accumulator by one A-1→A	A	3A	2	1	N---Z-
INC (INA) increment accumulator by one A+1→A	A	1A	2	1	N---Z-
BRA branch relative always (2)	REL	80	2	2	
ADC add memory to accumulator with carry A+M+C→A	(IND) (5)	72	5 (4)	2	NV---ZC
AND "AND" memory with accumulator A∩M→A	(IND) (5)	32	5	2	N---Z-
CMP compare memory and accumulator A-M	(IND) (5)	D2	5	2	N---ZC
EOR "EExclusive OR" memory with accumulator A∪	(IND) (5)	52	5	2	N---Z-
EOR "EExclusive OR" memory with accumulator A∪ M→A	(IND) (5)	52	5	2	N---Z-
LDA load accumulator with memory M→A	(IND) (5)	B2	5	2	N---Z-

Table 2

old 6502		number of bytes	N	new 65C02		number of bytes	N
PHA	A↓	1	3	PHA	A↓	1	3
TXA	X↓	2	3	PHX	X↓	1	3
PHA	X↓	1	3	PHY	Y↓	1	3
TYA	Y↓	1	2				
PHA	Y↓	1	3				
PLA		1	4				
TAY	Y↑	1	2	PLY	Y↑	1	4
PLA	X↑	1	2	PLX	X↑	1	4
PLA	A↑	1	4	PLA	A↑	1	4

10 29

6 21

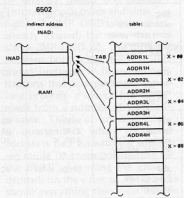
 bytes: 10→6 = -40%
 time: 29→21 = -27.6%

program:



LDA TAB,X
 STA INAD
 LDA TAB+1,X
 STA INAD+1

65C02

program:



table:

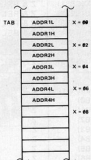

83125

Large alphanumeric LED displays

Regisbrook Ltd have added another new line to their impressive range of specialist opto-electronic components by acquiring the marketing rights to the German-built Elcos MA 35 large-scale alphanumeric character displays.

The highly flexible LED displays have a character height of 31 mm, making them ideal for large public signs or point-of-sale advertising applications. MA 35 displays feature a 5 x 7 dot matrix, and are designed for tight side-to-side stacking to provide an uninterrupted message, visible through a wide viewing angle of 140 degrees.

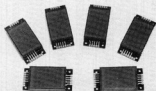

The devices are available in red, yellow or green and are fully compatible with a wide range of drivers and power supplies. They are designed for simple solder connection, and are drilled for mounting.

By adding the MA 35 large-scale displays to their existing stock lines, Regisbrook complete a product portfolio which can effectively cater for any display application from micro-circuit indicators up to massive public information systems.

*Regisbrook Limited,
Studio House,
215 Kings Road,
Reading RG1 4LS
Berkshire.
Telephone: 0734 665955*

(2768 M)

'The smartmouth speech synthesiser'

Smartmouth is a small, self-contained unit that sits alongside the computer. It has its own loudspeaker, as well as an auxiliary audio output socket. No specialist installation is required and it does not require soldering. A single connection to the 'User Port' gives the unit all its data and power requirements. It comes complete with 'demo' and development programs on cassette and full software instructions.

Low memory requirements

Due to its unusually low memory requirements, typically using only 4 - 8 bytes per word, it is now possible to incorporate speech into existing pro-

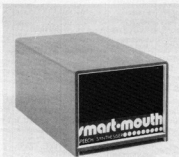

grams without using up massive amounts of memory. Alternatively, a dedicated 'speech' program is able to contain several thousand words.

Infinite vocabulary

Being unlimited in its vocabulary, Smartmouth allows the easy creation of any English word. Regardless of whether your interest lies in the Scientific, Technical, Educational or Recreational field, Smartmouth can say the words you need.

Ease of use

The instructions supplied explain how to string together individual speech sounds, (Allophones) to produce your words. As there are only 64 Allophones to choose from, words can be assembled with both ease and speed. (Examples chosen from a wide variety of words are listed.)

The Smartmouth is available exclusively from Technomatic, at £37.00 + £2.00 p&p + VAT and has a full year guarantee.

*Technomatic Ltd.,
17 Burnley Road,
London, NW10 1ED.
Telephone: 01452 1500*

(2773 M)

Desk-top cases

A new, lightweight case primarily intended for desk-top applications such as intercoms and controls is now available from West Hyde.

Attractively styled with smooth contours, the Empress case is manufactured from 2mm aluminium and has a black and natural anodised finish. It has a sloping top surface at the front which places

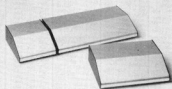

switches, knobs and meters at an ideal angle.

The case is available in four sizes, all with a common profile, so that two or more can be placed side by side on a worktop to form attractive 'suites'.

The Empress case is supplied complete with self-adhesive feet and is available ex-stock from West Hyde.

*West Hyde Developments Ltd.,
Unit 9 Park Street Industrial Estate,
Aylesbury,
Bucks. HP20 1ET.
Telephone: 0296 20441*

(2776 M)

LCD thermometer

A hand-held LCD thermometer which costs under £25 including VAT, delivery, battery and post and packing, is being marketed by Hero Electronics.

The price of £24.95 in one off quantities means this precision thermometer can be used in many domestic as well as industrial applications and represents a major breakthrough in pricing.

The thermometer incorporates a high definition LCD display with a measuring range of 0°C to 99.9°C which can be read to an accuracy 0.1°C. The sensor and lead clip neatly into the case and can be easily



detached. A hinge support, and fixing recess enable the portable instrument to be converted for wall, or table top mounting.

The thermometer is currently being used by the electronics industry to measure component temperatures. It has a wide range of Industrial uses wherever temperature measurement of air, liquids or body surfaces is required. In the domestic field uses envisaged are in: photography, greenhouses, wine and beer making and in checking the flow and return temperatures in domestic heating.

*Hero Electronics Limited,
Dunstable Street,
Amphill,
Bedfordshire MK45 2JS.
Telephone: 0525 405015*

(2775 M)

Junior-Paperware

(in 2 vols.)

The floppy disk is probably the most significant mass storage medium for microcomputers. It seems incredible that so much data can be stored on a simple plastic disk at such speed and with such precision.

Unfortunately, it is not enough to just connect a floppy disk drive to a microcomputer. Without software the hardware is useless! Where can you get all the necessary source listings, hex-dumps, and EPROM modifications? In the Elektor Junior paperware, of course!

Junior paperware 1 contains the modifications of the PM/PM EPROM and the source listings and hex-dump of the software cruncher and puncher; Junior paperware 2 gives the source listing of the bootstrap loader for Ohio Scientific Floppys and the hex-dump of the EPROM.

Elektor
Publishers Ltd
Canterbury

Price £2.00 + 50p postage & packing per volume (outside U.K. £1.00).

To order, please use the prepaid order card at the end of this issue.



MARCO TRADING

MULTIMETER SPECIAL

Russian type U4324 20,000 ovp

d.c. Voltage: 0.6, 1.2, 3, 12, 30, 60, 120, 600, 1200.

a.c. Voltage: 3, 6, 15, 60, 150, 300, 600, 900.

d.c. intensity m/a: 0.06, 0.6, 6, 60, 600, 3000.

a.c. intensity m/a: 0.3, 3, 30, 300, 3000.

d.c. resistance: 0.2, 5, 50, 500, 5000 kOhm.

g.e. level dB: 10 + 12.

PHILIPS VIDEO PROJECTION SCREENS - 60"

Also improves effect of cine film. Only 14 available. Price £50 each (incl. VAT)

2N5495 - RCA	p	£	each	50p	C
BC308A	10 for 50/100 for 3/1000 for 20				
BC170	10 for 50/100 for 3/1000 for 20				
TIS90	10 for 50/100 for 3/1000 for 20				

TRIAC - 10 A 400V mounted on 60 x 50 mm Heatsink each

	65p	(p/8p 35p)
10 for	£5	(p/8p £150)

RESISTOR KITS

1/2W - 10 each value 10R to 1Meg. E12 range, 510 Resistors £5.00 per pack

1/4W - as above but only 5 each value 305 Resistors £3.00 per pack

1/8W - 10 each value 2R2 to 2M2. E12 range, 730 Resistors £6.00 per pack

LINEAR SMOOTHING CAPACITORS? 7

200 µF + 200 µF @ 300 V. Tag ended. Dimensions: 4 x 1 1/2"

Price: each 50p (p/8p 30p per capacitor)

10 for	£4.00	(p/8p £3.00)
--------	-------	--------------

BUY NOW WHILE STOCKS LAST!

TRANSFORMERS

British made transformers at very attractive prices.



Primary	Secondary	Current	1+	10+	100+
240 V	4.5-0-4.5 V	400 mA	50p	45p	35p
240 V	6.0-6 V	100 mA	58p	52p	43p
240 V	6.0-6 V	500 mA	65p	60p	48p

(Postage & Packing: 45p per transformer or £1.60 per 10, £4.50 per 100)

These very high quality British made two pin European adaptors are ideal for driving Radios, cassette recorders, TV games, calculators etc. The adaptor fits in the UK 3 pin socket.

EUROPEAN ADAPTORS



REF	D.C. Voltage	Current	1+	10+	100+
EOB	4.5 V	200 mA	50p	45p	32p
EM3	6 V	200 mA	£1.00	80p	55p
EO9	6 V	400 mA	£1.50	£1.25	85p

(Postage & Packing: 45p per adaptor or £1.60 per 10, £4.50 per 100)

Send now for our latest catalogue, 35p plus 30p P+P.

Over 72 pages packed with complete range of components. Includes Special Offer list, order form and pre-paid envelope. Please add 15% VAT to the above prices.

MARCO TRADING, DEPT. KK10

THE MALTINGS, HIGH STREET, WEM, SHROPSHIRE, SY4 5EN. Tel: (0939) 32763

All orders despatched by return of mail.

ROADRUNNER WIRING SYSTEM



Using this low cost, simple technique, you will speed up your wiring times and produce a very professional result!

Please take advantage of our special offers and order now!

Used extensively in industry this is a truly professional system ideal for the home engineer.

EXCLUSIVE OFFERS TO ELEKTOR READERS

EUROINTROKIT



ONLY
£16.99
20% SAVING!
NORMAL PRICE
£21.24

Consists: S/Eurocard, wiring pencil, 4 diff. coloured enamelled wire bobbins, TCW bobbins, 10 glue strips, 30 press strips, 100 solder pins.



ONLY
£5.99
20% SAVING!
NORMAL PRICE
£7.60

Spec - 240V 17W High temp iron, suitable for soldering enamelled wire.

Full instructions with kit

These offers are fully inclusive of carriage, packing and VAT.



VISA

We welcome orders using Access & Barclaycard.

Roadrunner Electronic Products Ltd.
UNIT 3 THE HASLEMERE INDUSTRIAL ESTATE
WEYDOWN ROAD, HASLEMERE, SURREY,
ENGLAND. GU27 1BT.
TEL: 0428 53850

Post Code

ELEKTOR ORDER FORM

Please send me kit(s) and/or Iron(s)

I enclose PO/Cheque for £

or debit my Barclay Card/Access No.

Signature (please print) _____

Name (please print) _____

Address _____

The name to remember in electronics.

Road Runner

MAKE ALL THE RIGHT CONNECTIONS

with a MAPLIN MODEM KIT

Exchange programs with friends, leave or read messages from the various Billboard services, talk to computer bureaux, or place orders and check stock levels on Maplin's Cashtel service. A Maplin Modem will bring a whole new world to your computer and vastly increase its potential.

Now you can exchange data with any other computer using a 300 baud European standard (CCITT) modem and because the Maplin Modem uses this standard, you could talk to any one of tens of thousands of existing users.

Some computers need an interface and we have kits for the ZX81, VIC20/Commodore 64, Dragon and shortly Spectrum and Atari, whilst the BBC needs only a short program which is listed in Projects Book 8.

A Maplin Modem will add a new dimension to your hobby.

Order As LW99H (Modem Kit) excluding case. Price £39.95.
YK62S (Modem Case). Price £9.95.

Full construction details in Projects Book 5.



See us at the
**ELECTRONIC
HOBBIES FAIR**
OCT. 27-30 1983

Maplin's Fantastic Projects



Full details in our project books. Price 70p each.

In Book 1 (XA01B) 120W rms MOSFET Combo-Amplifier ● Universal Timer with 18 program times and 4 outputs ● Temperature Gauge ● Six Vero Projects.

In Book 2 (XA02C) Home Security System ● Train Controller for 14 trains on one circuit ● Stopwatch with multiple modes ● Miles-per-Gallon Meter.

In Book 3 (XA03D) ZX81 Keyboard with electronics ● Stereo 25W MOSFET Amplifier ● Doppler Radar Intruder Detector ● Remote Control for Train Controller.

In Book 4 (XA04E) Telephone Exchange for 16 extensions ● Frequency Counter 10Hz to 600 MHz ● Ultrasonic Intruder Detector ● I/O Port for ZX81 ● Car Burglar Alarm ●

Remote Control for 25W Stereo Amp.

In Book 5 (XA05F) Modem to European standard ● 100W 240V AC Inverter ● Sounds Generator for ZX81 ● Central Heating Controller ● Panic Button for Home Security System ● Model Train Projects ● Timer for External Sounder.

In Book 6 (XA06G) Speech Synthesiser for ZX81 & VIC20 ● Module to Bridge two of our MOSFET amps to make a 350W Amp ● ZX81 Sound on your TV ● Scratch Filter ● Amp Meter ● Four Simple Projects.

In Book 7 (XA07H) Modem (RS232) Interface for ZX81/VIC20 ● Digital Enlarger Timer/Controller ● DXers Audio Processor ● Sweep Oscillator ● CMOS Crystal Calibrator.

In Book 8* (XA08J) Modem (RS232) Interface for Dragon ● VIC Extendboard ● Synchro ● Electronic Lock ● Minilab Power Supply ● Logic Probe ● Doorbell for the Deaf.

*Projects for Book 8 were in an advanced state at the time of writing, but contents may change prior to publication (due 13th August 1983).

NEW MAPLIN STORE OPENS IN MANCHESTER

Our new Manchester store offering the full range of Maplin's electronic components, computers and software will be opening 16th August, 1983. Part of the new store will be a self-service area where you can browse around and choose the parts you want. Counter service will be available as well. Upstairs you will find our computer demonstration area with displays of hundreds and hundreds of different software packages for Atari, BBC, Commodore 64, Dragon, Sord M5, Spectrum and VIC20.

You will find us at 8, Oxford Road opposite the BBC, between Piccadilly and the University complex. We're just a few steps from



Manchester's Oxford Road station and about five minutes walk from the city centre. There is excellent parking on meters in the adjacent sideroads and we're about five minutes drive straight in from junction 10 on the M63 at the start of the M56.

Call in and see us soon!

Great Projects From E&MM

Our new book "Best of E&MM Projects Vol. 1" brings together 21 fascinating and novel projects from E&MM's first year.

Projects include Harmony Generator, Guitar Tuner, Hexadrum, Synptom, Auto Swell, Partlyte, Car Aerial Booster, MOS-FET Amp and other musical, hi-fi and car projects.
Order As XH61R. Price £1.

★ 1983 CATALOGUE ★

Over 390 pages packed with data and pictures and all completely revised and including over 1000 new items. On sale in all branches of W.H. Smith. Price £1.25. Or send £1.50 (including p&p) to our mail-order address.



LEARN ROBOTICS

- with Hero 1; the new robot who sees, hears, speaks and detects movement!

This remarkable microprocessor-controlled robot is the perfect robotics training system for industry, home and schools. Hero 1 can see, hear, speak, detect moving and stationary objects and determine their distance, pick up small objects, move in any direction and can learn from your instructions.

Hero 1 is a superbly documented Heathkit kit.

Order As HK20W (Robot Kit) Price £1,599.95.



MAPLIN
ELECTRONIC SUPPLIES LTD

Mail Order: P.O. Box 3, Rayleigh, Essex SS6 8LR. Tel: Southend-on-Sea (0702) 552911.
Shops at: 159-161 King Street, Hammasmith, London W6. Tel: 01-748 0926.

284 London Road, Westcliff-on-Sea, Essex. Tel: (0702) 554000.

Lynton Square, Perry Barr, Birmingham. Tel: 021-356 7252

8 Oxford Road, Manchester. Tel: 061-236 0281. (Opens 16th Aug. 1983)

All shops closed Mondays.

All prices include VAT & carriage. Please add 50p handling charge if total order value is under £5.