

elektor

up-to-date electronics for lab and leisure

D 71683

98

June 1983

85 p.

IR 123p. (incl. VAT)

\$2.75

AIR-MAIL COPY

Spectrum Display
the ultimate Hi-Fi accessory!

Teletype decoder

Kilowatt-hour meter

Aerial switch

Sunshine Surf

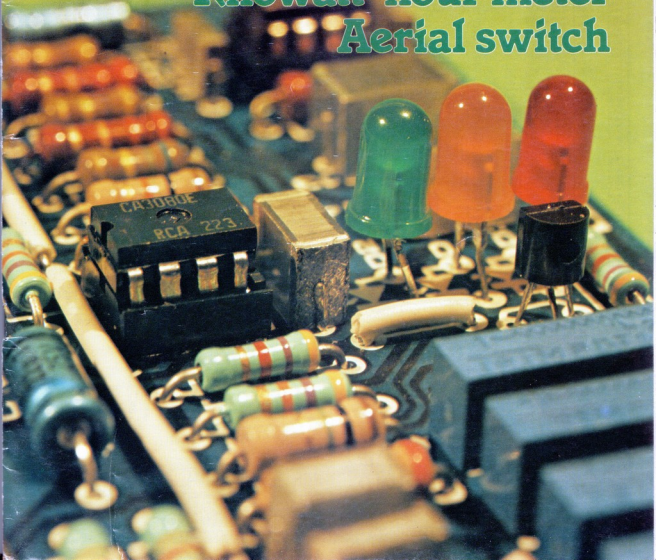

contents

selektor	6-21
energy meter	6-24
Our follow-up to last month's watt-meter, which enables you to keep an eye on the energy used by one or more appliances and on the effect of your energy-saving measures.	
switching channel for radio control	6-28
Proportional radio control systems are readily available to modellers today. This article describes a switch which offers the possibility of controlling five non-proportional functions over one channel.	
RTTY decoder	6-30
Last month we published an article on a morse decoder; now we turn to an instrument for converting teletype signals to logic 1s and 0s which can be fed to a microprocessor and displayed on a screen. An EPROM with the required program is available.	
electronic aerial switch	6-36
A simple but effective method, using PIN diodes, to switch from one to another of a number of aerial inputs without introducing losses in the signal paths.	
spectrum display	6-38
An interesting instrument which offers Hi-Fi enthusiasts (and other listeners) the opportunity to see what is really coming out of their amplifiers on a 10-column, 140 pixel fluorescent display. The audio range of 16 ... 23,000 Hz is displayed in 10 octaves. The spectrum display can be used with any existing audio installation.	
maestro (part 2)	6-46
The conclusion of this versatile infra-red remote control originally developed for our Prelude project but which can be used with a variety of other equipment.	
video effect generator	6-50
This article describes ways and means of obtaining images on your television screen which are strongly reminiscent of trick photography.	
morse and radio teletype (RTTY)	6-52
This article describes the principles of morse telegraphy and RTTY operation in some detail. Not only advanced radio amateurs and listeners but a host of others interested in the captivating hobby of listening to morse and RTTY messages on short wave radio should find many points of interest.	
applicator	6-58
Fluorescent display system which can be driven directly by a computer and yet uses only one integrated circuit.	
market	6-62
switchboard	6-67
EPS service	6-80
advertisers index	6-82

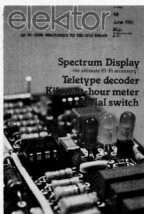

As LEDs have now been commercially available in red, green and orange/yellow for some time, they are found in many electronic applications. None the less, our front cover does not mean that we have gone into the miniature traffic light business. What is shown are the 'signal trafficators' used in the Radio Teletype decoder featured in this issue.

Standa Engel

From the world's largest manufacturer of scientific instruments



Beckman instruments are used worldwide in medicine and science, in industry and environmental technology, where precision and reliability are vital: from the Beckman photo-spectrometer in a space probe scanning for signs of life to a Beckman clinical electrolyte analyser.

World's widest range of hand-held multimeters

This same perfection in design and manufacture goes into Beckman digital multimeters, themselves widely used in testing, measurement, research and engineering because of their accuracy and their intelligent features.

Now the electronics enthusiast has access to the same standard of reliability in the T90, T100 and T110 models.

Digital performance at analogue cost

All models undergo 100% factory testing. Their accuracy is guaranteed to be held over a long period and reliability is outstanding, thanks to fewer components and interconnections. All components are of the highest quality and include a CMOS integrated circuit and gold inlaid switch contacts.

The digital display can be read at a glance, and all functions are selected with a single rotary switch, rather than with confusing rows of push buttons.

Battery life is exceptional - 200 hours at continuous operation.

The T90 gives an accuracy of 0.8% Vac and is remarkable value for money at £43.45 (+VAT).

The T100 is a full range function meter with 0.5% accuracy at £49.00 (+VAT), while the T110 offers even greater accuracy of 0.25% plus an audible continuity indicator at £59.00 (+VAT).

To feel like a professional you can order your Beckman straight off the coupon, or send for full technical data.

BECKMAN

World leaders in multimeters

Beckman Instruments Ltd
Electronic Components UK Sales and Marketing Organisation
Mylen House, 11 Wagon Lane, Sheldon, Birmingham B26 3DU.
Tel: 021-742 7921 Telex: 336659

I want to go digital!

Please send me:

- T90 meters at £50.60 (inc. VAT, p&p)
 T100 meters at £57.00 (inc. VAT, p&p)
 T110 meters at £68.50 (inc. VAT, p&p)

I enclose a cheque/P.O. payable to:
Beckman Instruments Ltd for £

Please send me full data on the Beckman enthusiast's multimeter range. (Tick box if required)

NAME _____

ADDRESS _____

Please allow 14 days for delivery

NEW SLIMLINE MITSUBISHI

Disc Drive double sided double density, 80 tracks in a specially designed case for the BBC Microcomputer complete with cables and utility disc (400K capacity).

Price £239 + VAT = £274.85

Switchable between 40 and 80 track

Price £249 + VAT = £286.85

PLEASE PHONE FOR
FURTHER INFORMATION

Double sided/double density Double Tracks 5 1/4" Disk Drives

This is the latest addition to our range of disk drives. The capacity is 1 MEGA BYTES (unformatted) per drive, the track density is 96TPI. Track to track access time is 3 msec. These are compatible with Shugart SA460 (ANSI standard interface). Compatible with BBC COMPUTER, ATOM, NASCOM and lots of other computers.

One disk drive only..... £239 - VAT = £279.85
Two disk drives..... £469 + VAT = £539.35
Single boxed with power supply..... £274 + VAT = £319.10
Dual boxed with power supply..... £509 + VAT = £595.35
DS/DQ 5 1/4" disk drives..... £395 + VAT = £454.85 each
Two drive cable..... £15 + VAT = £17.25

PROFESSIONAL MONITORS

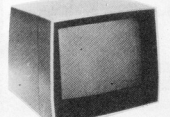

• **GREEN MONITOR** 12" green monitors with composite and sync input. Suitable for most computers.
Hiach MM1215..... £89 + VAT = £102.35
SM12H 18MHz monitor..... £89 + VAT = £102.35
SM12N 15MHz monitor..... £89 + VAT = £79.35

• **COLOUR MONITORS** 14" colour monitors, RGB or composite and sync input.
SCM14N Normal-res 400 dots..... £239 + VAT
SCM14M Medium-res 600 dots..... £339 + VAT
SCM14H High-res 800 dots..... £499 + VAT

KDS 7362 VDU

80 charac. x 24 lines
25x status line, RS
232C/20mA current loop interfaces,
128 displayable characters, reverse video, blink, blank underline, high intensity,
detachable keyboard with 101 keys.



AS USED WITH ICL PERSONAL COMPUTER
Our Price..... £449 + VAT = £513.35

ATARI HOME COMPUTERS

ATARI 400 - £159
ATARI 800
£399
Prices include VAT



BBC MICROCOMPUTER

• "OFFICIAL BBC DEALER"

BBC Microcomputer Model B..... £348 + VAT = £399
Model B + Econet interface..... £389 + VAT = £446
Model B + Disk Interface..... £409 + VAT = £469
Model B + Econet + Disk interfaces..... £450 + VAT = £516
Single disk drive (100K)..... £230 + VAT = £264
Torch Dual Disc Drive (800K) with Z80 processor 64K of RAM and Parallel printer cable..... £775 + VAT = £896
CPN operating system..... £775 + VAT = £896
Games Paddles (per pair)..... £11 + VAT = £12.65
Second Processor Z80..... £195 + VAT = £224.25

SOFTWARE FOR BBC COMPUTER
Desk Diary (Two programmes)..... £8.65 + VAT = £9.95
Algebraic manipulation package..... £8.65 + VAT = £9.95
BBC Peeko Computer..... £8.65 + VAT = £9.95
BBC FORTH language..... £14.50 + VAT = £16.67
BBC LISP language..... £14.50 + VAT = £16.67
BBC word processing package (view)..... £52 + VAT = £59.80
Printer Driver Cass..... £8.65 + VAT = £9.95

TEXAS INSTRUMENTS HOME COMPUTER SYSTEM



T199/4A 16 BIT MICROPROCESSOR
FREE CASSETTE LEAD SUPPLIED

This microcomputer is based on TMS9900 16 bit microprocessor. It includes 16K RAM, 16 colour high resolution graphics (192x256). The screen display is 32 characters, 24 lines TI-BASIC. Full size keyboard. For Software there are about 1000 Programs to choose from. There are a lot of peripherals available e.g. Disk Drives, Disk Interface, Speech Synthesiser, Extra RAM, Additional Languages (PASCAL, TI-LOGO, ASSEMBLER). Prices: TI Home Computer £149.95; Peripheral Expansion System £149.95; Disk Controller Card £144.95; Disk Drive £199.95; Speech Synthesiser £41.95. All prices inclusive of VAT. Please send large SAE for full price list.

GUARANTEED LOWEST PRICES

We guarantee that our prices are the lowest on the market. If you can find any item advertised and in stock at less than our price we will match that price.

NEW EPSON TYPE 3 PRINTERS



NEW FX 80 80 column, 160 CPS

£379 + VAT = £435.85

MX 100-3

136 columns, 100 CPS, all other features of MX80 plus true descenders, adjustable paper width up to 15 inches, friction or tractor feed, centronic parallel interface.
Price: £429 + VAT = £493.35

DRAGON 32

£169 + VAT = £194.35
INCLUDING A FREE CASS LEAD

This is a powerful new microcomputer specially designed for the family and small business use. It has 32K Bytes of Ram (expandable to 64K), 16K Byte MicroSoft Colour Basic. High-res. colour graphic and very good sound features. It has full size professional keyboard and comes complete with power supply and a built-in centronic parallel printer interface. Send SAE for lists.

CASIO CALCULATORS



*FX-702P the casio pocket computer/calculator, basic programmer, 55 scientific functions, up to 1680 program steps.

Special Price..... £61 + VAT = £69.95
*FX-602P programmable calculator, 50 scientific functions and 612 program steps..... £27 + VAT = £42.55

Price..... £46 + VAT = £52.90
*TA-2 cassette interface for FX-702 and FX-602..... £16 + VAT = £18.40

*FX-10 Mini printer for FX-702 and FX-602..... £27 + VAT = £42.55
*PB-100 pocket computer with query keyboard..... £39 + VAT = £44.85

Price..... £47 + VAT = £54.05
*FX700 Scientific pocket computer..... £47 + VAT = £54.05

SEIKOSHA GP SERIES GRAPHIC AND TEXT PRINTERS

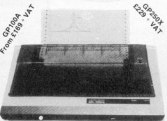

GP-100A 50CPS, 80 column Hi-res graphic, line repeat function, adjustable up to 17" page width, tractor feed, 5 x 7 dot matrix, GP-100A centronic, parallel interface, 50 CPS..... £189 + VAT = £217.35
GP100A 30 CPS..... £159 + VAT = £194.35

GP-250X New 80 CPS, 80 column tractor feed true descenders, 64 user defined characters, double height and/or double width characters, 5 x 8 dot matrix, parallel and serial (RS232C) interface..... £229 + VAT = £263.35
GP-250X..... £229 + VAT = £263.35

STAR DP PRINTERS

The most cost effective quality matrix printers to be launched this year. DP510 and DP515 features include friction and tractor feed and roll holders as standard, 100 CPS print speed bi-directional logic seeking 9 x 9 matrix gives true descenders, 2.3K buffer as standard. Hi-res bit image plus block graphics, sub and super script, italic printing, auto underlining, 2K user definable memory, vertical and horizontal tabulation, left and right margins set, skip over perforation, back space and self test.

Star DP510 17" carriage 80 columns
Price £279 + VAT = £320.85

Star DP515 15" carriage 136 columns
Price £379 + VAT = £435.85

FAST 100 CPS NEC 8023 PRINTER NEC 8023B-C



This is a high speed printer using bi-directional logic seeking operation, 7x9 matrix for alphanumerics, 8x8 for graphics and bit image printing. Programmable paper feed, original plus three copies, Greek characters and high resolution graphics. The print quality is exceptional, and the price is affordable.
Price..... £299 + VAT = £343.85

AKHTER INSTRUMENTS LTD.

DEPT EK, UNIT 19, ARLINGHYDE ESTATE, SOUTH ROAD, HARLOW, ESSEX, U.K. CM20 2BZ
TEL: HARLOW (0279) 412639 TEL: 995801 - A18

ORDERING INFORMATION All orders which accompany a cheque or cash are CARRIAGE FREE (UK only). On all other orders a carriage charge of 3% of invoice total is applicable.
OPENING HOURS: Mon-Fri 9am-5.30pm, Sat 10am-2pm

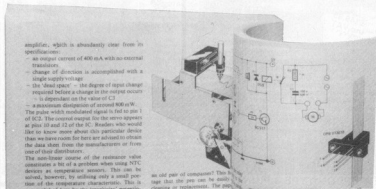
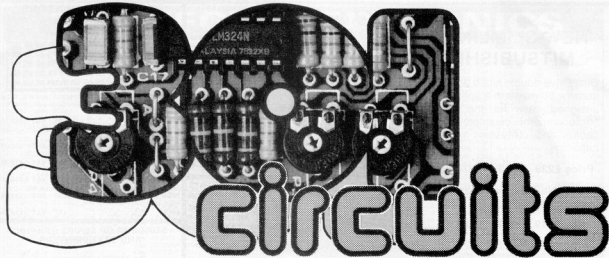

price £ 5.50
+ 50p P&P U.K. and overseas

Please use the Order Card in this issue.

amplifier, which is already clear from its specifications:

- an output current of 400 mA with no external transformer
- change of direction is accomplished with a single supply voltage
- the "dead space" - the degree of repair change required before a change in the output occurs - is dependent on the value of C2
- a maximum distortion of around 90 mV.

The pulse width modulated signal is fed to pin 1 of IC2. The control signal for the servo system is at pin 10 and 12 of the IC. Readers who would like to know more about this particular design than we have room for here are advised to obtain the data sheet from the manufacturer or from one of their distributors.

The non-linear nature of the resistance value necessitates a bit of probing when using NTC devices as temperature sensors. This can be solved, however, by providing only a small portion of the temperature characteristic. This is accomplished here by the "resistivity" characteristic P2 and P3, which effectively set the amount of differential output per degree of temperature change and the lower limit of the range respectively. This achieves a reasonable degree of accuracy, but of course, we are not striving to produce a piece of laboratory equipment. In reality, the circuit is only intended to record a change in temperature over a period of time rather than measure actual temperature.

The constructional points can be constructed quite simply. The servo can be mounted on a slip over the end of paper. The holder for the resistor pin can be glued or screwed to the end of the slip. As a holder for the pins, what better than part of

an old pair of compasses? The bearing that the pins can be easily changed or replaced. The pin type used in printing calculations should more as a form and contain the equipment in its operation. It can be made with the aid of most, but are generally used for model kit, general course, for a variety of quality available from surplus or Precision 2 Ball.

To prevent the NTC system from so on, wire should be taken when and P3 to keep the voltage accuracy 0.1%. If the voltage ratio allows that they will suffer considerably.

The circuit is completely TTL and the power supply can be a battery, 5 V type. When the it is used with a tape recorder, an external clock as possible in place of tape get wrapped into the wheels before the track is

246 End of tape detect.

This design incorporates a new type of photo-detector which has a large number of applications such as detecting breaks in magnetic tapes. Before the output of the detector reaches the control board, the signal passes through the following internal stages. The photo diode is followed by a linear amplifier which feeds a Schmitt trigger. In turn, the Schmitt trigger controls a second "tamper-proof" trigger. Specifically, its function is to prevent signals to be reduced considerably by the use of the Schmitt trigger. (2).

The sensor pulse output enables the a general photo-detectors in parallel also to have the circuit works with have a frequency 100 instead, detection give low and transistor T1 so that the relay is disconnected. The output of the relay keeps in the relay driver (forming a common) using power supply of the board. Even this Co-Au (cathode diode) reaches that the low output of the device can

CMOS pulse ge

are included. Furthermore, a comparison of the generation and the current drain on the circuit is generated. IC1. This IC is a 4-bit counter used by frequency range 2.20 and 7 MHz (also voltage) the pre-amplifier. If the output of the detector is 0.1 V or less, it should not be to the "0" level or continuously, with the signal can be used to trigger the counter. Similarly, the can meet the maximum frequency of the the other external inputs.

The output signals of the circuit are pin 10 and 11 of IC1. IC1 is a 5V CMOS. The trigger input is used as a pulse detector to prevent false output for external input of output of IC1 is also that

301 circuits

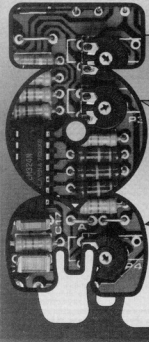

Elektor Publishers Ltd.

The book follows the theme, and is a continuation of our popular and very successful 300 circuits publication. It is composed of 301 assorted circuits ranging from the simple to the more complex designs described and explained in straightforward language. An ideal basis for constructional projects and a comprehensive source of ideas for anyone interested in electronics. In a nutshell something to please everybody.

ELECTRONIC KITS

ALL
NEW
to the
VELLEMAN
RANGE

Velleman electronic kits have gained respect for their high quality and the varied range which covers many applications in the vast field of electronics. All kits are designed and developed using the latest technology, giving them appeal, not only to the hobbyist and enthusiast but also to the experienced engineer.

The fully illustrated Velleman Kit Journal is available free of charge upon request and has full technical specification on each kit in the range. All kits are graded by difficulty from 1 to 3 and can be purchased direct or from the stockists listed below.

... and remember, we have a 'rescue service' for instances where enthusiasm exceeds ability!



K2584 - Precision timer
Timing from 7 sec.
to 99 mins 59 secs.
Actual size: 235 x 110mm

K2586 - Serial Controller/ Emulator
(designed primarily for use with
K2578 Velleman Eprom programmer)
Actual size: 100 x 160mm.

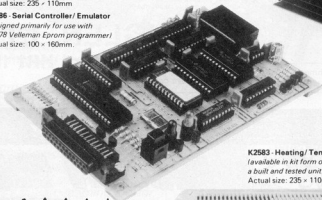

K2583 - Heating/ Temperature Controller
(available in kit form or as
a built and tested unit)
Actual size: 235 x 110mm

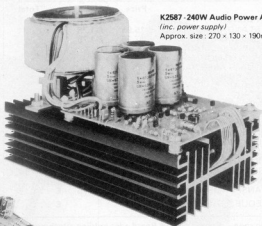

K2587 - 240W Audio Power Amplifier
(inc. power supply)
Approx. size: 270 x 130 x 190mm high

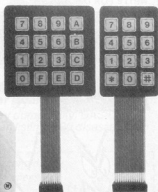

**KBS16 and KBS12 -
Membrane Keypads**
(available with
or without legend)
Actual size:
65 x 100mm
100 x 100mm

OTHER NEW KITS recently introduced

- K2580 Electronic powerswitch dimmer
- K2581 Stereo volume and tone control
- K2582 Stereo audio input selector
- K2585 Codeclock
- K2588 3 Channel sound to light unit

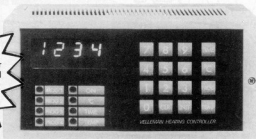

VELLEMAN UK Ltd

P.O. Box 30, St. Leonards-on-Sea,
East Sussex TN37 7NL, England.
Telephone: (0424) 753246



VELLEMAN STOCKISTS

Baxol Tele Exports Ltd., Ballinacash, Post Rathdrum,
Co. Wicklow, Rep. of Ireland.
Bradley Marshall Ltd., 325 Edgware Road, London W2 1BN.
S & R Brewster Ltd., 86-88 Union Street, Plymouth, Devon.
Marshalls Electronics, 85 West Regent Street, Glasgow, Scotland.
Retail outlets are required in most major towns and cities.
Write for full details, including retail discounts.

FREE

SOLDERING IRON
with orders of
£25.00 and over
when accompanied
by this
voucher.



Please send me your free catalogue of Velleman electronic kits:

Name.....

Address.....

EK



**DO YOU EVER NEED
A FEW MORE HANDS?**

**THE MINIBENCH[®] SYSTEM
puts YOU in control**

Post coupon today:

Name

Address

Please supply:

	Price	postage & packing	Total
MINIBENCH			
- STANDARD	£ 15.95	£ 1.75	£
- DE LUXE	£ 17.95	£ 1.75	£
- SUPER DE LUXE ON PLINTH-MOUNTED TURNABLE BASE	£ 32.50	£ 3.—	£
FLEXI-ARMS			
- SHORT	£ 4.75	£ 0.15	£
- LONG	£ 5.50	£ 0.15	£
LENS ATTACHMENT			
- 50 mm	£ 2.50	£ 0.15	£
- 75 mm	£ 3.25	£ 0.15	£
- 100 mm	£ 5.—	£ 0.30	£
CLIP ATTACHMENT			
- LARGE	£ 2.50	—	£
- SMALL	£ 1.50	—	£
LIGHT FITTING (ON F/ARM)	£ 7.50	£ 0.20	£
TRANSFORMER UNIT	£ 15.—	£ 0.75	£
CHEQUE/P.O. ENCLOSED FOR			£

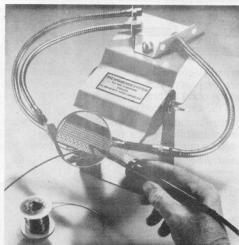

- ★ Just a squeeze to clamp or release circuit board.
- ★ Adjustable minimum jaw aperture
- ★ Jaws flip over for work on either side of circuit board
- ★ Rubber lined jaws for circuit board protection & maximum grip
- ★ Single wing nut controls jaw attitude and friction setting
- ★ Crocodile clips mounted on flexi-arms hold components exactly where needed
- ★ Crocodile clip can be used as a heat shunt
- ★ Lens similarly mounted is ideal for close work and spotting those solder bridges
- ★ Flexi-arms keep station with circuit board
- ★ Attractive stove enamel two-tone finish
- ★ Built to last a lifetime!

ABSONGLEN LTD.
P.O. Box 13 Hereford HR1 1EA

•Trade mark. Patent pending

Coming soon — Printed Circuit Board edge holding attachment — WRITE FOR DETAILS

THE FIRST ELECTRONIC COMIC-BOOK

RESI & TRANSI BANISH THE

MYSTERIES

OF ELECTRONICS

Excitement, entertainment, circuits.
Complete with printed circuit board and Resimeter.

Further adventures and circuits coming soon — starring Resi & Transi, of course!

Elektor Publishers Ltd., Elektor House,
10 Longport, Canterbury CT1 1PE,
Kent, U.K.
Tel.: Canterbury (0227) 54430.
Telex: 965504.
Office hours:
8.30 - 12.30 and 13.30 - 16.30.
6-16

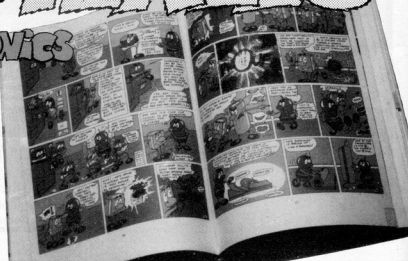

THE COMPLETE PACKAGE! MICROPROFESSOR PLUS THE STUDENT WORK BOOK



A low cost tool for learning, teaching and prototyping.

Micro-professor is a low-cost Z80 based micro computer which provides you with an interesting and inexpensive way to understand the world of microprocessors.

Micro-Professor is a complete hardware and software system and is a superb learning tool for students, hobbyists and microprocessor enthusiasts, as well as an excellent teaching aid for instructors of electrical engineering and computer science courses.

Micro-Professor **£99.50**
(+£4.00 p&p)

Now with the Student Work Book available Flight offer you the complete package. An easy to follow manual that will help further your understanding of microprocessors.

Student Work Book **£16.00**

FLIGHT
Electronics Ltd.

Micro-Professor is a trade mark of Multitech Industrial Corporation. Z80 is a trade mark of Zilog inc.

SGB-MPF Sound Generation Board

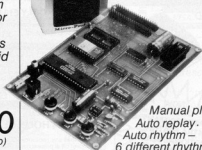

Manual play,
Auto replay.
Auto rhythm -
6 different rhythms,
Sound Synthesizer
and Hi-Fi speaker.



EPB-MPF EPROM Programming Board

For all +5V 1KB/2KB/4KB EPROMS
Read/Write/List/Verify Capability.

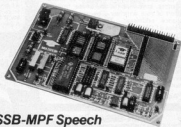

SSB-MPF Speech Synthesizer Board

A vocabulary of up to 400 words based on the TMS 5200 chip.

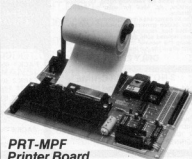

PRT-MPF Printer Board

Memory dump utility. BASIC program listing. Z80 disassembler.

Please send me	Qty
Micro-Professor	£99.50
	(+£4.00 p&p)
Student Work Book	£16.00
SGB-MPF board	£79.50
EPB-MPF board	£99.50
SSB-MPF board	£99.50
PRT-MPF board	£86.25

I enclose cheque/P.O. for £.....

Name

Address

.....

.....

Mail Order only

Prices include VAT. Please allow 28 days for delivery.

FLIGHT ELECTRONICS LTD.
Quayside Rd. Southampton,
Hants SO24AD. Telex. 477793.
Tel. (0703) 34003/27721.

EKR 6



By phone or post

HOME LIGHTING KITS

These kits contain all necessary components and full instructions & are designed to replace a standard wall switch to control up to six of the following:

- TD300K Remote Control **£14.30**
- MKB Dimmer Transmitter for above **£4.20**
- TD300K Touchdimmer **£7.00**
- TDEK Extension kit for 2-way switching for above **£2.00**
- LD300K Rotary Controlled Dimmer **£3.50**



HOME CONTROL CENTRE

This kit enables you to control up to 16 different appliances anywhere in the house from the comfort of your armchair. The transmitter... programme addressed. The transmitter also includes a COMPTON interface so you can programme your favourite micro (e.g. ZX81) to switch lights, heating, electric blanket, make your morning coffee, etc., automatically without leaving your house. JUST THINK OF THE POSSIBILITIES. The kit includes all PCBs and components for one transmitter and two receivers, plus a pre-drilled box for the transmitter. Order as XK112 **£42.00**

Additional Receivers XK111 £10.00

"OPEN-SESAME"

The XK103 is a general purpose infra-red transmitter/receiver with one transmitter (normally optional relay contact) and two receiver outputs. Designed primarily for controlling motorised garage doors, two auxiliary outputs for drive/lights etc. at a range of up to 40 ft. The unit also has numerous applications in the home for switching lights, TV, closing curtains, etc. ideal for aged or disabled persons. The kit comprises a mains powered receiver, a 2-bay button transmitter, complete with pre-drilled box, requiring a 9V battery and one 500-ohm resistor plus a switch kit for inter-facing the receiver to mains appliances. As with all our kits, full instructions are supplied.

ONLY £23.75

3-NOTE DOOR CHIME

Based on the SAB000 IC the kit is supplied with all components, including loudspeaker, printed circuit board, a pre-drilled box (95 x 71 x 35mm) and full instructions. Requires only a PP3 9V battery and push-switch to complete. **£5.00**

AN IDEAL PROJECT FOR BEGINNERS. Order as XK102

THE MULTI-PURPOSE TIMER HAS ARRIVED

Now you can run your central heating, lighting, hi-fi system and lots more with just one programmable timer. At any selection it is designed to control four mains outputs independently, switching on and off at pre-set times over a 7 day cycle, e.g. to control your central heating (including different switching times for weekends), just connect it to your system programmer and set it and forget it—the clock will do the rest.

- FEATURES INCLUDE—**
- LED 12 hour display.
 - Day of week, am/pm and output status indicators.
 - 4 battery voltage switched mains outputs.
 - 800Hz mains powered programmes and continues time keeping during power failures. (Battery not supplied).
 - Display blanking during power failure to conserve battery power.
 - 18 programme time sets.
 - Powerful "Everyday" function enabling output to switch every day but use only one time set.
 - Useful "sleep" function—turns on output for one hour.
 - Direct switch control enabling output to be turned on immediately or after a specified time interval.
 - 30 minute keypad for programme entry.
 - Programme verification at the touch of a button.

(Kit includes all components, PCB, assembly and programming instructions). ORDER AS CT5000

Have you got your **FREE ORANGE CATALOGUE** yet?

NO? Send S.A.E. 16" x 9" TODAY!
It's packed with details of all our KITS plus large range of SEMICONDUCTORS including CMOS, LS TTL, linear, microprocessors and memories, full range of LEDs, capacitors, resistors, hardware, relays, switches etc. We also stock VERO and Antex products as well as books from Texas Instruments, Babani and Elektro.

ALL AT VERY COMPETITIVE PRICES.
ORDERING IS EVEN EASIER — JUST RING THE NUMBER YOU CAN'T FORGET FOR PRICES YOU CAN'T RESIST.

5-67 8-9-10 Answering service evngs & weekends

REMOTE CONTROL KITS

- FOR A DETAILED BOOKLET ON REMOTE CONTROL — send 30p + 6" x 8" S.A.E.
- MKS6 SIMPLE INFRA RED TRANSMITTER Supplied with hand-held plastic box. Requires 9V (PP3) battery. **£4.20**
 - MK7 INFRA RED RECEIVER Mains powered with special output to switch up to 500W at 240V ac. Range approx. 20 ft. on/off or 200mA d.c. **£12.50**
 - IRC 900K — price output for MK6/MK7 **£12.50**
 - MKS4 4 WAY KEYBOARD MK7 4 way keyboard transmitter where only 4 channels are required. **£1.90**
 - MKS10 16 WAY KEYBOARD MK11 16 channel 2 analogue dip receiver. A mains powered LR receiver providing control signals to 10 on/off and 3 analogue outputs. May be used for controlling the volume of an amplifier, brightness of a lamp, etc. **£12.90**
 - MK12 16 CHANNEL LR RECEIVER A mains powered LR Receiver providing up to 16 outputs for switching.

THE JUPITER ACE MICROCOMPUTER

Now available in stock

uses FORTH which executes about 10 times faster and requires less program memory than a comparable program using basic. Features 8K ROM, 32K RAM, built in speaker, 40 key keyboard and a 32 x 24 line-flicker free display on TV. Comes supplied complete with leads, mains adaptor, a comprehensive easy-to-follow manual on FORTH programming + FREE cassette containing 5 sample programs.

ONLY £75.00

(+ £2.00 carriage + VAT)

ASIC SOFTWARE

- J3 SPACE INVADERS
- J4 SWAMP MONSTERS

J5 DOT MAN

- J7 ZAP 'EM (ASTEROIDS) DUCK SHOOT & MINEFIELD (3 programs)

WHY NOT COME IN AND SEE IT FOR YOURSELF!

COMPONENT PACKS

- PACK 1 600 Resistors 47 ohm to 10 Mohm — 10 per value £4.00
- PACK 2 40 x 10V Electrolytic Capacitors 10µF to 1000µF — 5 per value £2.25
- PACK 3 80 Polyester Capacitors 0.01 to 1µF 25V — 15 per value £5.55
- PACK 4 45 50V-miniature Presets 100 ohm to 1 Mohm — 5 per value £2.90
- PACK 5 30 Low Profile IC Sockets 8, 14 and 16 pin — 10 of each £2.40
- PACK 6 25 Red LEDs (5mm dia.) £1.25

ELECTRONIC LOCK KIT XK101

This kit contains a purpose designed lock IC, 10-way keyboard, PCBs and all components to construct a Digital Lock, requiring a 4-kk sequence to open and providing over 5000 different combinations. The open sequence may be easily changed by means of a pre-wired plug. Size: 7 x 6 x 3 cms. Supply: 5V to 18 V d.c. at 40uA. Output: 750mA max. Hundreds of uses for doors and garages, car anti-theft device, electronic equipment, etc. Will drive most relays direct. Full instructions supplied.

ONLY £10.50

Electric lock mechanism for use with latch locks and above kit **£13.50**

XK113 MW RADIO KIT

Based on 2N414 IC, kit includes PCB, wound aerial and control electronics and all components to make a sensitive miniature radio. Size: 5.5 x 2.7 x 2cms. Requires PP3 9V battery. IDEAL FOR BEGINNERS. **£5.00**

24 HOUR CLOCK/APPLIANCE TIMER KIT

Switches any appliance up to 1kW on and off at present times once per day. Kit contains: AY-5129 IC, 0.5" LED display, mains supply, display drivers, switches, LEDs, tracks, PCBs and full instructions.

DVM/ULTRA SENSITIVE THERMOMETER KIT

This new design is based on the ICL7218 in lower power version of the ICL7106 chip and a 3 1/2 digit liquid crystal display. This kit will measure on the basis of a digital multimeter (only a few additional resistors and switches are required) a stable supply of a sensitive digital thermometer -10°C to +150°C reading to 0.1°C. The basic kit has a sensitive 200µV for a full scale reading, automatic polarity indication and an ultra low power requirement—giving a 2 year typical battery life from standard 9V PP3 when used 8 hours a day, 7 days a week.

Price £15.50

DISCO LIGHTING KITS

DL1000K This value for money kit features a 3-dimensional sequencer, control of speed of sequence and frequency of direction change. It is controlled by means of potentiometers and incorporates a mass driver circuit. **£14.60**

DL120K A lower cost version of the above, featuring unidirectional channel sequencing, automatic level control and built in mic. No features to speaker or lamp required. 150kinds to adjust — simply connect to mains supply and lamps. (15k channel)

Only £11.95

MINI KITS

MK1 ELECTRONIC THERMISTAT Uses LM301C IC to sense temperature (0°C) and track to switch heater (1kW). Mains powered.

MK2 SOLID STATE RELAY Switches 240V AC lights, heaters from logic/computer circuits. Zero voltage switching, opto-isolated. **£2.60**

MK4 PROPORTIONAL TEMPERATURE CONTROLLER Uses "burnt free" technique to maintain temperature within 0.5°C. Ideal for photography, horticulture, wine making, etc. Max. load 30W (240V ac). Temp. range up to 90°C. **£5.90**

MK5 MAINS TIMER Mains powered timer enabling a load up to 1kW at 240V ac to be switched on (or off) for a variable time from 20 mins. to 28 hrs. Longer or shorter periods possible with minor modifications. **£5.90**

MK18 DUAL LATCHED STATE RELAY Complete two MK2s with latch circuit enabling the MK12 IC to control two mains loads independently. Full output tracks not supplied. (See remote control kit.) **£5.50**

NEW MK15 DC CONTROLLED AUDIO AMPLIFIER

Controlled with virtually any stereo audio amplifier to control bass, volume, treble and balance remotely, either using a wire link or the MK11 infra red receiver. A 7 of 10 decoder with LEDs is also included to give input selection/display. (See remote control kits.) **£10.70**

CT1000K Basic Kit **£14.90**
CT1000K with white box (56x131 x 71mm) (Ready Built) **£17.40**
£22.50

CT1000K with white box (56x131 x 71mm) (Ready Built) **£17.40**
£22.50

Add 65p postage & packing + 15% VAT to total Overseas Customers. Add £2.50 (Europe), £6.00 (elsewhere) for p&p Send S.A.E. for LITERS STOCK DETAILS. Goods by return subject to availability.

OPEN 8am to 5pm (Mon to Fri)
10am to 4pm (Sat)

ALINGS NORTH CIRCULAR RD
CLOCK TOWER 8C

For a detailed booklet on remote control send us 30p and S.A.E. (16" x 9") today. **EXCLUDE VAT**

LCD 3 1/2 DIGIT MULTIMETER
16 ranges including DC voltage 200m-1000 and AC voltage, DC current 100mA-10A and resistance (0-2M) + NPN & PNP transistor gain and diode check. Input impedance 10M. Size 155x82x31mm. Requires PP3 9V battery. Test leads included. **ONLY £29.50**

FAST SERVICE - TOP QUALITY LOW LOW PRICES

No circuit is complete without a call to -

ELECTRONICS EK

11 Boston Road London W7 3SU

ACCESS BARCLAYCARD

TEL. 01-567-8910 ORDERS
01-579 9794 ENQUIRIES
01-579 2842 TECHNICAL AFTER 5PM



Raindrops and radar

A new type of radar is able to probe rain to measure the drop-size distribution and rate of rainfall and to distinguish rain from ice cloud. It is an important research tool for the study of climate and of the effect rain may have on high-speed aircraft and radio communication.

Radar has proved a remarkable tool to tell us, rapidly, how rain is distributed over large areas. It also enables us to examine what rain there is well above ground level. While the data it provides is good enough for general weather forecasting, it contains too much ambiguity to be used in estimating the rainfall rates in areas of heavy rain. Such information is important to research into flash flooding, crop damage and the attenuation of signals along paths of radio communication.

Ambiguity is there because the rainfall rate, and the amount of radar signal reflected by the rain, may represent a heavy concentration of small drops on the one hand or relatively few but large drops on the other; it is the statistical distribution of drop sizes that governs the relationship between the rainfall rate (or attenuation of a radio wave) and the reflectivity, or echo of the radar signal.

Dual polarisation

To overcome these problems a unique, dual-polarisation radar has been built at Chilbolton, in the South of England, and it is now in use there to map rainfall rates rapidly and accurately in three dimensions. It has a high spatial resolution, that is, an ability to separate reflections by angle and range, and clearly distinguishes between regions of ice clouds and rain. It has a pencil beam only a quarter of a degree wide,

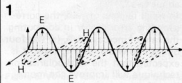

Figure 1. An electromagnetic wave has an electric field E and a magnetic field H, at right angles to each other and to the direction of propagation. In this representation the wave is travelling from left to right. All the E vectors lie in the vertical plane and all the H vectors in the horizontal plane. The plane in which the E vector moves is called the plane of polarisation.

2



Figure 2. Because large raindrops become distorted as they fall, they give a lot more back-scatter from horizontally polarised waves than they do from waves with vertical polarisation, whereas small drops, remaining almost spherical, back-scatter both types of wave in sensibly equal amounts.

made possible by its fully-steerable antenna, 25 metres in diameter. Because radio waves at the very short wavelengths normally used for radar are heavily attenuated by rain, a relatively long operating wavelength of 10 cm has been chosen so that distant rain can be measured accurately without the signal being attenuated by other rain between it and the radar.

All radio waves comprise an electric field and a magnetic field, oscillating in planes at right angles to each other and to the direction of propagation of the wave. This is shown in figure 1, where E is the electric field and H the magnetic one.

The plane in which E oscillates is called the plane of polarisation of the wave. If it is vertical, the wave is said to be vertically polarised, and if horizontal, it is said to be horizontally polarised. The polarisation can be selected at the aerial system which transmits (and receives) the wave.

The basis of the dual-polarisation technique is that the balance between aerodynamic and surface tension forces on the raindrops causes them to flatten as they fall, whereas small drops tend to remain spherical, as shown in Figure 2. When a region of mainly big drops is illuminated by radar pulses consisting alternately of horizontally and vertically polarised waves, the power back-scattered by the horizontally polarised wave is larger than that when using vertical polarisation. Conversely, for a region of mainly small drops, the back-scattered power is similar for both polarisations.

Research in the USA, suggested that the differential reflectivity, which is the ratio of the powers in the back-scattered and vertically polarised waves, is directly related to the mean of the statistical distribution of drop sizes in rain. Being able to measure this differential reflectivity accurately is the big advance which has been made.

Typical data

Figure 3 shows data the radar gave when scanning vertically through rain. In (a) we see a measure of the radar reflectivity of the rain, termed the absolute reflectivity factor Z, measured with horizontal polarisation only. This is precisely what a conventional radar (using single polarisation) would show, assuming that it operated on a 10-cm wavelength and had an antenna 25 metres in diameter, similar to ours. Prominent is the region of high reflectivity extending to a height of 6 km at a range of 35 km.

In (b) we see the spatial distribution of the additional differential reflectivity Z_{DR} data (using dual polarisation), the rain being sampled at the same time as in (a). The column of high reflectivity at a range of 35 km has a high Z_{DR} (it is greater than 2 dB) up to 2 km above ground, but Z_{DR} is low (the mean value is only 0.13 dB and the standard error 0.27 dB) at heights between 2 and 4.5 km. Such an abrupt change in Z_{DR} is often found close to the 0°C isotherm, and marks the transition from ice particles to water drops. Icy particles that have a low density, for example mixtures of ice and air such as snow, have a low refractive index; unless they are very asymmetric, they show a low Z_{DR} . Furthermore, compact ice particles which have a high density inevitably give low values of Z_{DR} if they are nearly spherical; but if they have an irregular shape they are likely to tumble at random and also show low Z_{DR} .

Polarisation switch

Our fast switching system to polarise the radar pulses in the appropriate

3

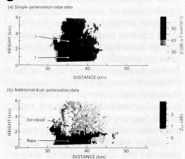

Figure 3. These vertical scans of the radar beam give a comparison of (a) data obtained using single polarisation and (b) data from dual polarisation. The information about ice cloud and rain below it was not resolved in (a).

way is based on a rapidly-rotating chopping vane, as shown in figure 4. Pulses from the transmitter arrive at a T-junction in the waveguide, from which they are passed alternately by open windows in the vane to one or other of two discrete pathways shown as vertical and horizontal polarisation arms; the windows open in synchronism with the generation of the pulses.

The paths merge again at a turnstile polariser, which is a sort of waveguide 'cross-roads'. Two of the four 'roads' are short stubs of waveguide, one of which is half-a-wavelength long and the other only a quarter-wavelength. The ends of the stubs are closed, so energy seeking to travel along them is reflected back to the junction. But, because of the difference in stub lengths, the waves arrive back in such a way that, when the energy recombines, all of it becomes directed into a circular waveguide leading to the aerial system, one pulse being vertically polarised and the next one horizontally polarised, and so on. Finally, the pulsed wave is 'fired' into the aerial's paraboloid reflector by a scalar feed, which is shaped to distribute the energy into the reflector. The pattern of the pencil beam formed by the reflector, with its diameter of 25 m, is identical for both polarisations. Waves returning to the receiver follow precisely the same path as for transmission, but in the reverse direction. The mechanical vane was used because no available solid-state device was capable of switching the 500-kW pulses at a pulse repetition rate of 610 pulses/second. Switching has to be that fast, for the raindrops are continuously in motion relative to one another and interference between the reflections contributed from individual drops gives rise to rapid fading of the returned wave; the data samples for both polarisation have to be obtained in a short enough time for such fluctuations to have no effect.

The technique requires Z_{DR} to be measured precisely; the measured standard deviation of the random errors lies between 0.05 and 0.1 dB, depending on the mean value, with a corresponding fixed error (inherent to such a measuring system) of less than 0.1 dB. Corresponding errors for Z are 0.75 and 1.0 dB, respectively. This means that estimated errors in measured rainfall are less than 40 per cent, and only about 10 per cent in the measured rate at which a radio wave is attenuated along its path by the rain.

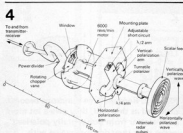

Figure 4. Dual polarisation switch and feed assembly. Windows in the rotating chopper vane pass the radar pulses from the transmitter alternately to the vertical polarisation and horizontal polarisation arms. When the energy reaches the turnstile polariser, some of it passes into the quarter-wave arm and some into the half-wave arm. Energy reflected from the terminations of the arms recombines in such a way that the pulses fed to the aerial via the scalar feed are polarised alternately in the vertical and horizontal planes.

Satellite communications

The aim in building the radar was to examine the way that small zones in intense rain affected radio links, particularly links between ground stations and satellites, so that theoretical models could be produced for use in planning communications systems. The ability to observe rain over large areas and up to considerable altitudes gives radar an immediate advantage over rain gauges on the ground. Attempting to predict attenuation by rain along the communications path from reflectivity data obtained by conventional radar means making an assumption about the distribution of the raindrop sizes. Furthermore, such data are likely to be misinterpreted when hydrometeors other than rain, for example snow or hail, are present. Dual-polarisation radar overcomes these problems. Only rain within a few tens of metres from the direct path of communication contributes to attenuation, so relatively small but intense features in the structure of the rain may produce short but deep fades. Knowing the drop size distribution is particularly important, because it changes quite rapidly within the rain zone.

Verification

To test the technique, data from the radar was compared with those from a satellite-to-ground radio link operated at a frequency of 12 GHz (gigahertz) by the UK Independent Broadcasting Authority at a station five kilometres from the radar site. Figure 6 shows how Z and Z_{DR}

varied during one set of measurements. The two ordinate scales show the slant range r along the communication path and the corresponding altitudes.

$A_C(r)$ is the summation of attenuation caused by rain along the path, progressively from the ground station. It is seen that the rate of increase in $A_C(r)$ is highest at slant ranges between two and four kilometres from the station, where the rain is most intense. In that region, both Z and Z_{DR} are high. At an altitude of three kilometres and a slant range of six kilometres there is a region of high Z and apparently high Z_{DR} . This is the altitude at which falling ice crystals or snow melt to become raindrops. The large, wet snowflakes are sometimes more easy to recognise from their differential reflectivity than from their absolute reflectivity. In this instance, rain below this altitude contributes 2 dB of attenuation, whereas the attenuation caused by wet snow has to be evaluated by other means because we are no longer dealing with drops of water. Tests have been done for light rain on only a few occasions the drop sizes are generally small; and in such conditions the technique is least accurate, but almost all values of radar-derived attenuation computed so far have been within 0.5 dB of direct measurements, the standard deviation being only 0.3 dB.

In the small, intense cells of rain which accompany thunderstorms and which cause the highest attenuation, drop sizes are usually larger and the accuracy may be expected to be greater. For rain examined, the estimation of the attenuation using the absolute reflectivity alone (all that is available from a conventional radar), and assuming a constant statistical distribution for the drop sizes, produced an error factor of about two.

In small regions of rain, the corresponding error factor in computing the rate of increase in $A_C(r)$ was four. Subject to wider-ranging tests, it is expected that the dual-polarisation technique will improve the modelling of attenuation by rain over a range of radio frequencies, and enable several studies to be made of how to keep the effects of rain on future communications systems to a minimum.

Other applications

The technique should be important to other work, too. Measurements have shown that the largest drops in intense rain have a diameter

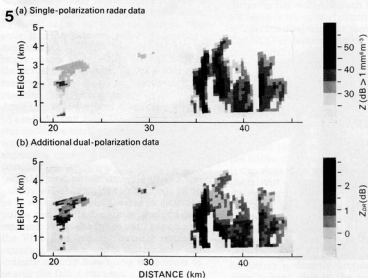

Figure 5. Here a pillar of supercooled water is seen so extend up through the melting layer (at an altitude of 1.9 km) to a height of 3.5 km. Such phenomena are a hazard to aircraft, causing ice to form.

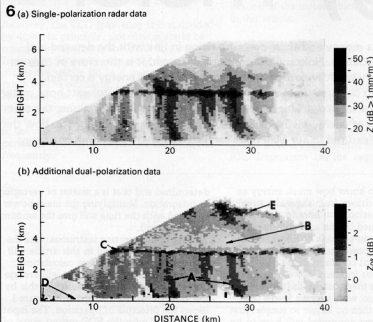

Figure 6. Vertical scan of the radar beam showing rain (A), ice cloud (B), the melting layer (bright band), echoes from ground (D), and zones of high Z_{DR} (E) well above the melting layer.

of more than 0.8 cm. In the particular conditions investigated, if we assume an exponential distribution of drop sizes, one drop in the rate of 0.55 to 0.65 cm diameter would occur per 2.4 m^3 volume of rain, and one in the range of 0.65 to 0.75 cm would occur per 7.0 m^3 . This sort of information is useful to scientists

interested in the effect that raindrops have on high-speed aircraft and to others seeking to assess what heavy rain might do to crops. Detecting regions of supercooled water is potentially valuable in aeronautics, for they can cause ice to accumulate rapidly and disastrously on aircraft. Figure 6 contains an

example of high Z_{DR} values extending to the top of the region of high Z . This indicates a convective column of supercooled drops up to an altitude of 3.5 km, nearly twice the height of the melting layer. Without dual-polarisation measurements, it would not be clear whether such regions of high Z represented ice cloud or drops of water.

We are also thinking about how the technique could be used to avoid certain problems met with when using radars to forecast how rain is likely to travel in the following hour or two. Although it is not essential to know the drop size distribution in rain accurately if we want to estimate average rainfall over a large area, the dual-polarisation technique is likely to help us automatically distinguish rain from non-precipitating ice clouds (and from ground echoes, too, because they are characterised by the large variance of their Z_{DR} . The variance includes quite large negative values not found in echoes from other sources).

There is also a great deal in the technique to interest cloud physicists. Figure 6 shows vertical sections through rain, ice cloud, the melting layer (bright band) and echoes from ground. It also shows, well above the melting layer, zones of high Z_{DR} which probably contain horizontally-orientated plates of ice crystals; later, the crystals aggregate and tumble as they fall, giving near-zero Z_{DR} . Basic studies of drop sizes in rain are being made on the ground with the aid of a drop-sizing device known as a Joss distrometer and a rain gauge, while measurements of drop sizes in the air are being made with a 2-D Knollenberg distrometer carried in a research aircraft of the UK Meteorological Office. Data collected directly in that way, when combined with data from the radar, are revealing how well we may expect a simple model to behave when used to describe the statistical distribution of drop sizes in various kinds of rain. Another promising application lies in providing reference data with which to compare the remote-sensing of clouds by satellites. Observations from the satellites may cover the whole of the Earth's atmosphere, but where they fall within the range of the radar, the radar data can be used to calibrate those from the satellite in terms of rainfall below the cloud and, perhaps, the type of hydrometeor within the cloud.

Martin Hall, *Spectrum*

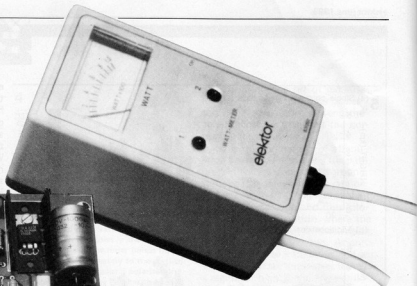
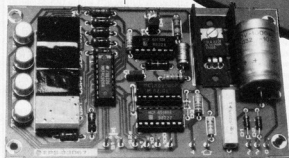

energy meter

from watt to
kilowatt-hour
meter

Energy costs money and these costs are rising in line with the demand and shrinking resources. Nobody escapes these costs and it is therefore of interest to all but very wealthy consumers to know how much energy a certain appliance has consumed over a certain period of time. A (kilo)watt-hour meter will tell you accurately. This knowledge will also help in determining the cost-effectiveness of energy-saving measures. In this article we will tell you how the watt-meter featured in our May issue can be expanded to become an energy meter.

If you want to know how much energy an appliance has drawn from the mains supply over a given period, you have to multiply the power consumed by the appliance in watts with the time in seconds or hours. Unfortunately, the power consumed by many appliances is not constant; in the case of a refrigerator, for instance, the motor only runs when the thermostat tells it to and even then it does so with varying loads. The calculation is then no longer so simple: first the mean power consumed will have to be

determined and that is a matter of averaging or integration. Multiplying the mean power so found with the time will give the amount of energy used.

The use of a measuring instrument like the energy meter described in this article will obviate the need for these calculations: fairly simple electronic circuits will average the power consumed and multiply this by the time. The block diagram in figure 1 shows the principle of operation. The input circuit is fed with the VCO output signal of

Figure 1. Block schematic diagram of the circuit necessary to expand the watt-meter published in our May issue into an energy meter. The extension consists of a digital counter which counts pulses produced by a VCO in the watt-meter. The number of pulses is directly proportional to the measured power and time.

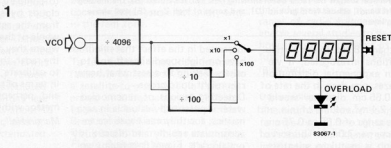

the watt-meter. The frequency of the VCO signal is in direct proportion to the power measured by the watt-meter: the higher the power, the higher the frequency. To convert the watt-meter to an energy meter only the addition of a fairly simple digital counter is needed. The VCO frequency is first divided by 4096; dependent upon the desired meter-scale, it is then divided by 10 or 100 (this increases the measuring range by 10 and 100 respectively). The dividers are followed by the actual counter which gives a four-digit read-out. Finally, there is a reset switch for resetting the circuit to zero.

Assuming that the watt-meter is connected to a refrigerator, the moment the motor of this appliance starts to run, the VCO in the watt-meter will provide countpulses to the expansion circuit which are directly proportional to the power consumed by the fridge. If that power varies, the VCO frequency will change. When the fridge motor switches off, the VCO ceases to generate pulses and the last counter position is retained. When the fridge switches on again, the VCO fires and the counter resumes counting. After a while the counter will indicate exactly how many watt-hours of energy the fridge has used.

The counter has a maximum capacity; the overload indicator gives warning that the counter has gone through this maximum and started again: if there were no such indicator, the displayed count could be misleading.

As stated, the VCO frequency is first divided by 4096. In principle, this divider could be omitted by operating the VCO at a lower frequency. However, not only does the higher frequency lie in a more suitable range for the oscillator, but it also has the advantage that the switch-on periods of an appliance can be averaged out much more accurately. This is of particular importance in the case of appliances which, within the period of measuring, switch on and off quite frequently.

The VCO

A description of the operation of the VCO was not included in the article on the watt-meter in the May issue, and this follows now. The circuit diagram of the VCO is shown in figure 2. Although in fact it is not a voltage but a current controlled oscillator, its operation remains the same.

The VCO is designed round an operational transconductance amplifier (OTA), A6, and operational amplifier A4 which is connected as a comparator. Dependent upon the measured power, transistor T1 provides the OTA with drive current. The current from T1 also charges capacitor C1 in a time which is again dependent upon the measured power. The resulting voltage level across C1 is applied to the input of comparator A4 via the buffer stage contained in the OTA stage. If this voltage exceeds the upper threshold, the output of the comparator goes negative. At the same instant the input current (pin 3) of the OTA also becomes negative, which causes C1 to discharge at a speed which is dependent upon the drive current at pin 1. In this way the VCO provides a square-wave at its output of which the frequency is directly proportional to its drive current, that is, the measured power. The hysteresis of the comparator, and consequently the frequency of the VCO, can be adjusted by means of potentiometer P4. This is of importance during the calibration of the meter which is discussed later in this article.

Energy meter extension

The circuit shown in figure 3 enables the watt-meter to be converted to a kilowatt-hour or energy meter. As stated, the input of the circuit is connected to the output of the VCO in the watt-meter. The VCO signal is applied to the input of 1 : 4096 divider IC2 via voltage divider R2-R3. The divided square wave is again divided by 10 or 100 in IC3. Dependent on the required scale,

energy meter
elektor june 1983

2

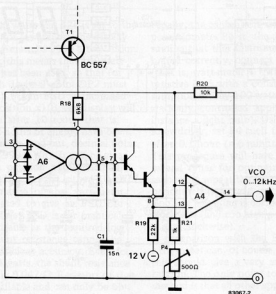

Figure 2. The VCO which is located on the printed circuit board of the watt-meter consists of an OTA (A6) and an op-amp (A4) which is connected as a comparator with hysteresis. Dependent on the power consumed, the OTA is fed with a certain drive current and arranges, in combination with the comparator, for the successive charging and discharging of capacitor C1. The output of the comparator therefore consists of a square wave of which the frequency is dependent upon the measured power.

switch S2a can apply the output of IC2 to counter IC5 either directly or via IC3. The integrated counter drives a four-digit 7-segment display. The decimal points of the display are determined by the position of S2b (the meter range switch).

The counter is reset by pressing push-button switch S1; at the same time the two dividers IC2 and IC3 are reset to the zero-position. To get an indication when the counter has reached its maximum capacity, use is made of its 'carry out' terminal (pin 14). At the moment the counter changes from 9999 to 0000, the logic bit at pin 14 changes from 1 to 0, which causes capacitor C3 to charge via resistor R5. When the resulting voltage at the clock-input (pin 3) of bi-stable IC4 reaches logic 1, its output Q also becomes 1 (+5 V). Transistor T1 is then fired and LED D4 lights, indicating that the counter has gone past its maximum at least once. It should be noted here that when the counter and dividers are reset, the bi-stable should also be reset to zero.

Although highly desirable, the reset facility is not fitted on electro-mechanical kilowatt-hour meters provided by Electricity Boards, for obvious reasons. On the meter described, the facility is not just useful, it is essential: at the onset of each measurement, the meter is reset so that noting down the reading at the start becomes unnecessary.

As far as meter ranges are concerned, switch S2 makes possible the selection of three. The scale factor is a somewhat more difficult problem, as this is dependent upon the divide factor and the shunt resistance in the watt-meter. This problem will be returned to later in this article.

The watt-meter and kWh extension can be fed from one 2 x 15 V, minimum 0.7 A, transformer. The voltage stabiliser, IC1, of the kWh section reduces the voltage rectified by diodes D1 and D3 to 5 V. The stabiliser is protected against overload by resistor R1. This resistor is replaced by a wire-bridge if the kWh extension is fed by a separate transformer of 2 x 8 V or 2 x 9 V (minimum 700 mA) transformer.

Construction and adjustment

Readers who took our advice of delaying the fitting of the watt-meter in a box, can now house it together with the kWh extension in one case, which, from a safety point of view, should be made from a material that is a good insulator.

If the kWh section gets its own case, the connection between it and the watt-meter needs special attention. As the zero potential of the watt-meter circuit is connected electrically with the mains supply during measurements, the cable between the two cases must be capable of carrying 220 V AC. If a plug and socket connection is desired, these *must not* be of the ordinary household variety. There are many good quality 220 V handling types available which can be used and in effect prevent the units being inadvertently connected to the mains supply. When a plug and socket connection is chosen, the extension must, of course, have its own power supply.

To revert to the scale factor of the meter and the way S2b should be connected to the decimal points of the display, see figure 3. When the watt-meter gives full-scale deflec-

Figure 3. With this circuit the watt-meter is converted to an energy meter. The pulses generated by the VCO are applied to the input. The meter range is increased by connecting a further divider (IC3) between the input and counter IC5 by means of range switch S2. LED D4 lights up when the counter has reached its maximum capacity. Switch S1 is included to reset the circuit to zero.

3

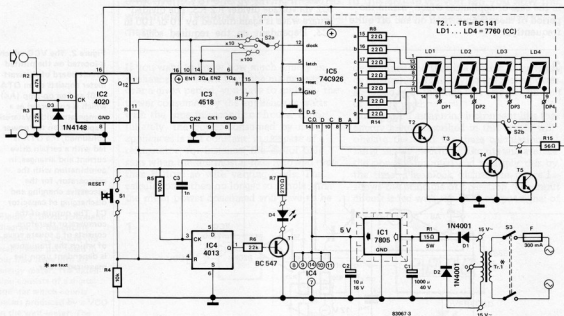

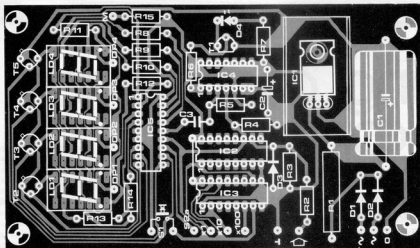
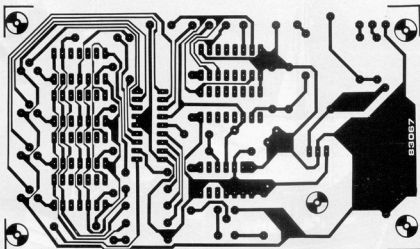

Parts list

Resistors:

- R1 = 15 Ω /3 W (see text)
 R2 = 47 k
 R3,R6 = 22 k
 R4 = 10 k
 R5 = 100 k
 R7 = 270 Ω
 R8 ... R14 = 22 Ω
 R15 = 56 Ω

Capacitors:

- C1 = 1000 μ /40 V
 C2 = 10 μ /16 V
 C3 = 1 n

Semiconductors:

- T1 = BC 547
 T2 ... T5 = BC 141
 IC1 = 7805
 IC2 = 4020
 IC3 = 4518
 IC4 = 4013
 IC5 = 74C926
 D1,D2 = 1N4001
 D3 = 1N4148
 D4 = LED (red)
 LD1 ... LD4 = 7760,
 7-segment display
 (comm. cath.)

Miscellaneous:

- S1 = push-button switch,
 1 make
 S2 = range switch,
 2-pole, 3-way

Tr = mains transformer

- a) 2x15 V, minimum
 0,7 A
 b) 2x15 V, minimum
 0,7 A, with taps at
 8 V or 9 V
 c) 2x9 V, minimum
 0,7 A (kWh extension
 only) see text
 heat sink for IC1
 equipment case (watt-
 meter only) = BOC440
 (watt-meter + kWh
 extension = BOC445)
 (available from West Hyde
 Developments Ltd)

tion (FSD) at 100 watts and S2b is set to the lowest divide factor (as drawn), the display will read the maximum of 9999 after 1 hour. In round figures, this means that 100 watt-hours of energy has been used, so that for a read-out in Wh decimal point DP2 must light (99.99 Wh). When FSD is increased tenfold (S2 in position x10), the display will reach maximum after 10 hours, that is, when 1000 watt-hours of energy has been used. If Wh are to be read out, decimal point DP3 must light (999.9 Wh). It will be clear that with S2 in position x100, decimal point DP4 should light; FSD is then 10 kWh. The shunt resistance of the watt-meter has been calculated to give an FSD of 1000 watts: a larger FSD is for practical reasons not advisable as the required low value of the shunt resistance cannot be realised with sufficient accuracy. Even for an FSD of 1000 watts, the shunt resistance has a value of only 0.047 Ω . Resistors of that value are not available and can only be obtained by three 0.15 Ω resistors in parallel or by using resistance wire.

Finally, the calibration, which only concerns potentiometer P4 in the watt-meter. Assuming that that instrument has been calibrated correctly, connect the energy meter (that is, watt-meter + kWh extension) to a resistive load with a constant power consumption of, say 100 watts (NOT a thermostatically controlled appliance, but for instance a light bulb). Using an insulated screwdriver, set P4 such that the display after 0.1 hour (= 6 minutes) reads 10Wh. This procedure will have to be repeated several times for optimum results. Subsequently, repeat the adjustment for 1-hour periods when the read-out should be 100 Wh. Too low a reading is corrected by turning P4 clockwise (and too high a reading by turning it anti-clockwise).

A comparison with the Electricity Board kWh meter can, of course, also be made and this should give a very satisfactory calibration. The only point to remember in this method is that all other appliances connected to the mains supply must be switched off.

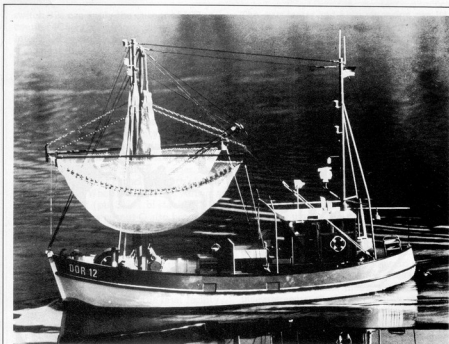

switching channel for radio control

The proportional radio control systems which are available to modellers today are ideal where it concerns the control of speed and steering mechanisms. Many models, particularly model ships, have, however, a number of non-proportional on/off functions which modellers would like to control remotely: interior lighting, search lights, sirens, water cannon, and many more. The switch described in this article offers the possibility to control five such functions over one channel without the need for servo-mechanisms and micro-switches.

pulse-width controlled switch

Proportional remote control systems operate by pulse-width detection. The position of the joystick results in a certain width of the transmitted pulses (between 1 and 2 milliseconds). The width of the pulse is translated in the receiver to a certain position of the servo control.

This type of proportional servo-control lends itself eminently to the continuously variable regulation of speed and steering, but the control of switching functions is somewhat more difficult, unless the use of a channel for every one or two such functions is acceptable. Fortunately, a small electronic circuit can improve the situation considerably; it consists of a one-gate oscillator, a decimal counter and a few buffers. Its principle is simple: when a pulse is received, a counter with five outputs operates; at the end of the pulse, one of the five outputs is active - which one depends on the width of the pulse.

The circuit diagram of the pulse-width controlled switch is shown in figure 1. The transmitted pulses have, as already stated, a width varying between 1 and 2 ms and

are repeated at intervals of about 20 ms. As soon as such a pulse arrives at the input of the circuit, two things happen in quick succession. The positive edge of the pulse (that is, the very start) switches on counter IC2 via gate N4. Almost immediately afterwards, when the pulse reaches logic 1, the clock oscillator around N3 starts and IC2 commences counting. The clock oscillator provides a 5 kHz square-wave, which can be adjusted by means of P1. As long as the oscillator is working, therefore, IC2 is clocked every 0.2 ms.

IC2 is a decimal counter working as a shift register, which, in principle, can provide up to ten switched outputs; only five are used in the present circuit (because the pulse-width lies between 1 and 2 ms). Starting from zero, IC2 switches every 0.2 ms to the next successive output. After 1 ms, therefore, output 5 will be logic 1, after 1.2 ms output 6, and so on. It is seen, therefore that on the command of the pulses produced by clock oscillator N3, all outputs of IC2 become logic 1 in succession. The sequential switching of the outputs

Figure 1. Circuit of the pulse-width controlled switch. As soon as a pulse arrives at the input, outputs 5 . . . 9 become active (logic 1) sequentially. When the pulse ceases, the output which was active at that moment, retains logic 1. This particular output is determined by the width of the incoming pulse.

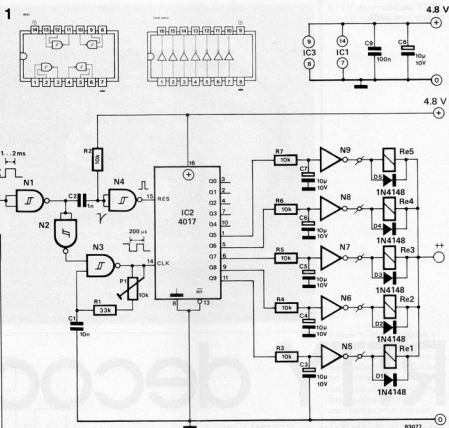

N1 . . . N4 = IC1 = 4093
N5 . . . N9 = $\frac{1}{2}$ IC3 = ULN2003

Figure 2. This picture shows that reality differs somewhat from theory: the input pulse (upper trace) fires the oscillator (second trace). The first period is a little longer than normal because C1 was fully discharged at that moment. This additional delay is compensated partly by the positive edge caused by the stopping of the oscillator and partly by the fact that the first positive edge occurs already after half the period. Trace 3 shows the signal at output 8 and trace 4 that at output 9. The latter was active (logic 1) and becomes 0 because IC2 resets at the rising edge of the input pulse; during the ninth positive edge of the oscillator, output 9 becomes 1 again and remains so until the next input pulse.

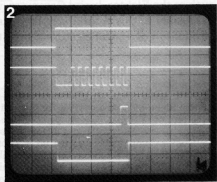

continues only for as long as the pulse lasts: when it ceases (and therefore the logic 1 disappears from the input), the counter output which was logic 1 at that moment, retains that state until the next pulse arrives after 20 ms. If this pulse, and the next, and the next, have the same width, the same counter output remains 'active' with only a short break every 20 ms when a new count procedure is initiated. However, by means of R3/C3 . . . R7/C7, the output signal is integrated over a few periods, so that the effects of the short break are obviated. At the open-collector output of gates N5 . . . N9 a logic 0 is therefore available at all times. The switching of small lamps (drawing less than 400 mA) can be effected by connecting them between one of the outputs of these gates and the positive supply line. Other switching functions are possible by the use of a relay: the relay coil, which should

preferably be more than 100 Ω and on no account less than 20 Ω , is then connected between one of the outputs and the positive supply line.

Operation

The circuit works very well in practice, not in the least due to the impossibility of short interfering signals or the effects of missing pulses reaching the output. Also, the current consumption of only a few mA is hardly a drain on the battery. Connecting the circuit to the receiver should pose no problems as it is connected in exactly the same way as a normal servo.

Adjusting the circuit is also a straightforward affair. Preset potentiometer P1 is adjusted such that all channels switch correctly when the joystick is moved from one extreme to the other. It would be useful to draw some lines beside the joystick to mark the position where the switch-over from one channel to the next occurs. During operation all that has to be done then is to set the joystick between two of the lines to ensure correct operation.

A final remark: output gates N5 . . . N9 must not switch more than 400 mA and preferably considerably less; this prevents unnecessary problems and premature repairs. It is, however, possible to utilize the two unused buffers of IC3 to either treble the permitted output current of one of the outputs or double that of two of the outputs. All that is required to do so is to connect the appropriate output(s) to the relevant buffer input.

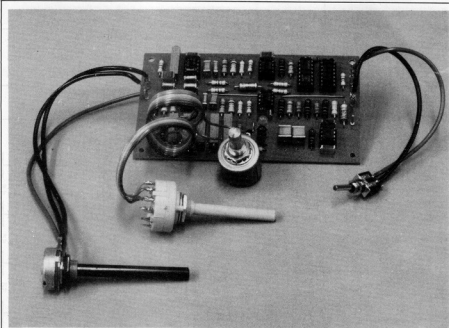

RTTY decoder

Interest in Radio Teletype (RTTY) traffic has grown appreciably over the past few years. One of the reasons for this is that micro-computers, such as the Elektor Junior Computer, which find their way into more and more homes, lend themselves readily to this absorbing hobby. Such a computer can become an effective RTTY Decoder by the addition of a small electronic circuit and a suitable program.

teletype reception by computer

Our last issue contained articles on the decoding of morse signals by means of the Junior Computer and the Elektor Z80A card. In this issue it is the turn of teletype enthusiasts.

Owners of an expanded Junior Computer can save themselves the purchase of a costly teleprinter and RTTY converter. A simple interface and an EPROM with the right program will translate the teletype gibberish on short waves into a clear text on the screen.

The principle of transmission and decoding in teletype is not much different from that in morse. Digital coded information is transmitted by interrupting a radio carrier wave: this is called CW (keyed Continuous Waves). In morse transmissions, the interruptions are in accordance with the by today's standards somewhat cumbersome morse code; in teletype, with the logically constructed 5-unit CCITT Code No. 2, better known as the Baudot code. A more detailed treatment of this subject can be found elsewhere in this issue.

Apart from the codes, there is another fundamental difference between morse and teletype operation. In morse, only one carrier is transmitted which is interrupted in the rhythm of the dots and dashes of the morse code. In teletype operation two

carriers are used, of which one is used for the transmission of the logic 1s and the other for the 0s. It is as if two transmitters are operating side by side, but each working on a different frequency. When the transmitted bit is 1, one of the transmitters is switched on, while the other is off; when the transmitted bit is 0, the first transmitter is off and the second is on. In reality only one transmitter is used of which the output frequency is shifted, according to whether a 1 or a 0 is transmitted. This method of operation is therefore called Frequency Shift Keying (FSK).

In teletype, logic 1 is called 'mark' and logic 0, 'space'. The transmission containing all the bits 1 is called the 'mark signal' and that containing only 0's, the 'space signal'. The mark and space signals are very close to one another: the frequency separation is called the 'shift'.

The output of the receiver therefore contains two different audio frequencies: one represents logic 1 (mark), the other logic 0 (space). When both are present simultaneously, there is a fault in the transmission.

The RTTY interface

The signals emanating from the short-wave receiver are not suitable for driving the

computer as this, as a norm, requires square-wave inputs. To modify the receiver output signals to the required shape, an interface is needed. This interface must be capable of differentiating between the two received frequencies and of transforming them into a digital signal. For this purpose use is made of a tone decoder followed by an integrator and Schmitt trigger. Two such set-ups are required in the RTTY interface because it has to cope with two different audio signals. With reference to figure 2, the level of the incoming audio signals is set as required by means of potentiometer P7 at the input of the circuit. Then follows a level indicator stage consisting of transistor T1 and a red LED, D1. The input signal is fed to two decoders, IC1 and IC2. Whereas tone decoder IC1 is aligned to one audio frequency, by means of potentiometer P8, decoder IC2 can be aligned to six different frequencies. This enables it to be switched to teletype transmissions with differing frequency shifts. Tone decoder IC1 is aligned to a nominal frequency of 1275 Hz. The frequency of decoder IC2 is then 1275 Hz \pm the shift frequency. Table 1 gives the shift- and

Table 1. Most frequently used audio and shift frequencies in RTTY traffic.

signal	set with:	frequency (audio) Hz	shift-frequency (Hz)
mark	P8	1275	0
space 1	P1	var.	var.
space 2	P2	1445	170
space 3	P3	1575	300
space 4	P4	1700	425
space 5	P5	2125	850
space 6	P6	2275	1000

audio-frequencies normally encountered in RTTY traffic.

The output circuit of the tone decoders contains three indicator LEDs: D2 (green) for the mark signal (IC1), D3 (red) for the space signal (IC2) and D4 (yellow) for the situation when a mark and space occur simultaneously. Because the frequency is shifted between mark and space, the overlap between the two signals during good reception is very small and D4 therefore lights rarely if at all. Bright lighting of D4 indicates a faulty adjustment or bad reception.

1

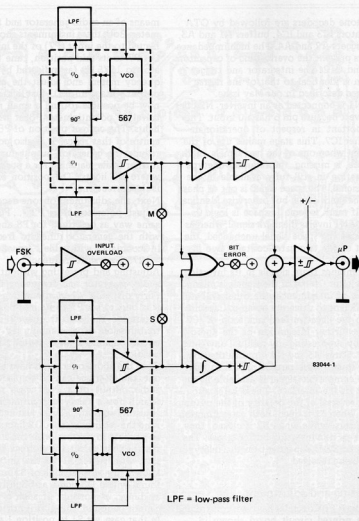

Figure 1. Block diagram of the RTTY interface. The interface consists of two tone decoders with follow-on integrators and triggers for noise and interference suppression. Its output contains an adder circuit which will deliver a usable signal even when one of the two audio signals (mark or space) is missing. The NOR connection of the tone decoder signals ensures an indication of transmission failure. With correct settings, the LED indicators for mark and space light alternately at maximum brightness, whereas the error LED lights only dimly.

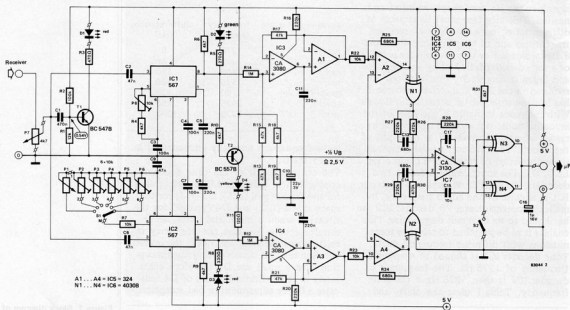

Figure 2. The interface circuit for teletype reception via the Junior Computer. It contains two tone decoders because in teletype operation two audio frequencies are keyed.

Both tone decoders are followed by OTA integrators IC3 and IC4, buffers A1 and A3, and triggers A2 and A4. The high-impedance buffers prevent the overloading of capacitors C11 and C12. The integrator and trigger section is identical to that of the morse interface described in our May issue.

Gate N1 is connected as an inverter; N2 does not invert because pin 6 has a 0 input. This is important in respect of operational amplifier IC7. This stage makes use of the fact that when one of the two signals, mark or space, is missing, the required teletype information is still fully available in the other signal. The space signal is out of phase with the mark signal but otherwise identical to it. If mark is logic 1, space is logic 0. Because N1 inverts the mark signal, whereas N2 passes the space signal unchanged, the output of the two gates contains two in-phase signals.

IC7 combines these signals in its inverting input circuit. If one of the signals is missing because of interference, the other will still be sufficient to drive the op-amp. Capacitor C15 in the negative feedback loop of IC7 ensures further integration of the audio signal by suppressing any residual unwanted signals. Gates N3 and N4 improve the slope of the square-wave output of IC7 so that a TTL compatible signal is available at the output of the interface. These gates also enable reversal of the polarity of the output signal. When S2 is open, both gates function as inverters, while when S2 is closed, they operate as non-inverting buffer stages. The setting of S2 is dependent on the teletype signal being received.

Presetting and adjustment

Once the RTTY decoder has been constructed on the printed circuit board shown in figure 3, it can be preset and adjusted by

means of an audio generator and frequency meter. Both these instruments should be connected to the input (P7) of the interface.

Set P7 to its mid-position, tune the generator to 1275 Hz (as indicated by the frequency meter) and adjust the generator output voltage until D1 just lights. It should now be possible to find a small range of travel of potentiometer P8 at which D2 lights. The correct position of P8 is in the centre of that range. It is also possible to reduce the generator output further and further while searching for a position of P8 where D2 lights. The position so found is the correct one.

Next, the adjustment of tone decoder IC2. Adjust potentiometers P2...P6 in the same way as described for P8 above, but with the generator tuned to frequencies in accordance with table 1 (space frequency = 1275 Hz \pm shift frequency).

Adjusting and presetting without using an audio generator and frequency meter is fairly difficult. When attempting to do so, it is best to set P7 to its mid-position and determine the shift-frequency of each transmission experimentally by adjusting potentiometer P1 with switch S1 set to position 1.

Once the above operations have been carried out, the interface can be connected to the audio output of a short-wave receiver. Search for a teletype transmission and adjust P7 so that LED D1 just lights. Then tune the receiver so that D2 lights as brightly as possible in rhythm with the incoming signal. Then select the correct frequency shift with switch S1. If the shift is not known, try all positions of S1 until one is found where D3 lights as brightly, and D4 as dimly, as possible. If such a position cannot be found, the shift is non-standard. In that case, set S1 to position 1 and adjust P1 to the shift of the incoming signal. When



Parts list

Resistors:

- R1 = 12 k
- R2 = 100 k
- R3 = 470 Ω
- R4, R5, R9, R10, R18,
R19, R31 = 4k7
- R5 = 270 Ω
- R7, R22, R23 = 10 k
- R8 = 330 Ω
- R11 = 120 Ω
- R12, R14 = 1 M
- R13, R15, R17, R21 = 47 k
- R16, R20,
R27 . . . R29 = 220 k
- R24, R25 = 680 k
- R26, R30 = 470 k
- P1 = 10 k 10-turn
potentiometer
- P2 . . . P6, P8 = 10 k
10-turn preset potentiometer
- P7 = 4k7 (5 k)
potentiometer

Capacitors:

- C1 = 470 n
- C2, C6, C9 = 47 n
- C3, C4, C7 = 100 n
- C5, C8, C11, C12 = 220 n
- C10 = 22 μ /3 V
- C13, C14 = 680 n
- C15 = 10 n
- C16 = 1 μ /6 V
- C17 = 1 n

Semiconductors:

- D1, D3 = LED red
- D2 = LED green
- D4 = LED yellow
- T1 = BC547B
- T2 = BC557B
- IC1, IC2 = LM 567
- IC3, IC4 = CA 3080
- IC5 = LM 324
- IC6 = 4030B
- IC7 = CA 3130

Miscellaneous:

- S1 = rotary switch,
1 pole, 6 way
- S2 = single-pole switch
toggle

Figure 3. The RTTY interface is constructed on this printed circuit board. The preset potentiometers are used for the setting of the various audio frequencies.

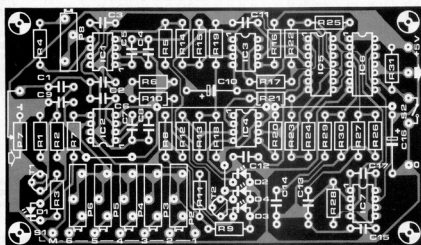
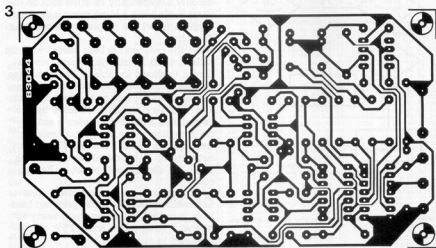

4

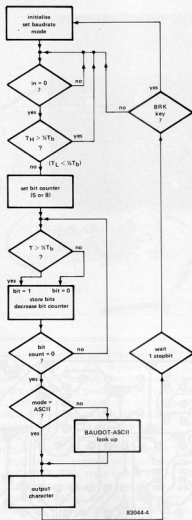

Figure 4. Simplified flow chart of the RTTY program. The 'heart' of the program is the bit counter. In contrast to an UAR/T which only scans the (calculated) centre of a pulse (unit of teletype signal), the counter determines whether the input signal during the pulse is longer than half the pulse duration for logic 1. If that is the case, it is taken to be 1, otherwise as 0. This system gives an appreciably lower susceptibility to interference, and therefore error rate, than is the case with UAR/T's.

reception is satisfactory and the interface is working correctly, the LEDs will flicker in rhythm with the incoming signal. All that remains is the presetting of the baud rate (at the computer) and the polarity of the incoming signal (set by S2). Both are a matter of trial and error as firm rules cannot be given.

The RTTY decoder program

The program of the RTTY decoder can be contained in an EPROM type 2716. This EPROM is then suitable for use with the expanded Junior Computer as well as the DOS Junior.

The RTTY interface is connected to pin PB7 of the Junior Computer. The RTTY program is so arranged that both 5-unit Baudot and 7-unit ASCII codes can be received. Moreover, the program allows up to six baud-rates. The received data are stored in a file buffer. When the buffer is full, an error signal is given. The contents of the buffer can, of course, be read out.

A further useful feature is the Auto-Letter-Mode: when receiving Baudot code, the letter sign is often lost. This results in letters being erroneously translated as numerals. In the Auto-Letter-Mode, the decoder automatically switches back to the letter mode when a blank space is received. Figure 4 shows the program structure in a flow chart.

When the program has been started with the address 4000, possible baud rates are displayed as shown in table 2. The computer will ask some questions which should be answered by Y (Yes) or N (No = Return). The baud-rate setting is effected by the keying in of a number between 0 and 5. On reception of an ASCII transmission, the question 'ASCII Receiver?' must be answered by Y, because if the answer N is given, the decoder will be set to Baudot code.

After questions as to file buffer, Auto-Letter-Mode, and file buffer print out have been answered, the computer is ready to receive a serial signal across PB7; this is indicated by the display ': :'. If the first question 'Do you like to change it?' is answered by N, the start procedure will be shortened. The decoder will then proceed in the Baudot mode with a baud rate of 50, indicated by the disappearance of the symbol ': : ' from the screen.

If you want to find out the mode of operation after the program has started, simply press the Break key on the ASCII keyboard. Reset or Change of Mode of Operation is effected with the NMI key.

Operating instructions for the RTTY program

The program requires a storage capacity from 4000 up to 7FFF (RAM). A (dynamic) 16K RAM card on the Junior bus will be suitable.

The starting address is 4000.

As the DOS Junior has a storage capacity which differs from that of the expanded Junior, the program for it has been put

Table 2. Print-out after starting the RTTY-program

```

BAUDRATE:
0=45.45 BAUD
1=50
2=57
3=75
4=100
5=110
DO YOU LIKE TO CHANGE IT? <Y/N>Y
SELECT THE BAUDRATE: 1
ASCII RECEIVER? <Y/N>N
FILE BUFFER? <Y/N>Y
AUTO LETTER MODE? <Y/N>
LIST THE FILE BUFFER? <Y/N>
: :
    
```

Table 3. Starting addresses for the copy procedures.

Junior versions	starting address	copied from	to address
expanded	0E88	0800	4000
DOS	EE72	E800	4000

electronic aerial switch

simple and
loss-free

from an idea by
C. Abegg

Many radio- and TV-amateurs have often wished they had a simple means of switching from one aerial to another. The normal solution is to do this by means of plug and socket arrangements, because a loss-free switch for changing aeriels is not as simple as it sounds. This article shows that aerial switching is possible without introducing losses into the signal paths.

The problem revolves around the losses caused by a mechanical switch. At relatively low frequencies (medium- and short-wave) such losses are not serious, but in the VHF and UHF bands they become a nasty problem. Even so, the most obvious and by far easiest way of selecting one of a number of aeriels is by means of a mechanical switch as shown in figure 1.

There is, however, a means of obviating the disadvantages of a mechanical switch at high frequencies and that is by using PIN diodes which are ideal for this purpose.

PIN diodes

What are PIN diodes? Briefly, they are special switching diodes of which the most important property is a very low self-capacitance while at high frequencies they are virtually purely resistive. The resistance can be varied between 1 and 10,000 Ω by means of a direct current, the so-called forward bias current, as shown in figure 2. It is clear from this figure that the resistance of such a diode changes linearly over a wide range of values of current. This characteristic is ideal for a number of applications: by varying the forward bias current, the PIN diode can be used for the attenuation, equalisation or even amplitude modulation of high frequency signals; by switching the forward bias current, pulse modulation and phase-shifting of high frequency signals becomes feasible.

In the aerial switch described here, the PIN diodes are used in a simple way: as a high frequency switch. The forward bias current is set relatively high and, apart from this current, the only requirement is a switch. Figure 3 shows how this works: when the switch is closed, the diode conducts; when the switch is open, the diode is cut off.

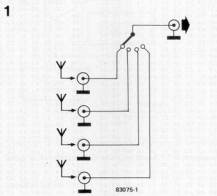

Figure 1. At medium- and short-wave frequencies, a normal switch can be used, but this would not be satisfactory at VHF and UHF.

Circuit description

Using PIN diodes, the switching between four aeriels does not, therefore, present a real problem. All that is required is a current supply, a 4-position switch and four PIN diodes (see figure 4).

In practice, there is, of course, a little more to it, but not much, as can be seen from the complete circuit diagram in figure 5. The required forward bias current can be obtained from a normal +12 V supply (mains transformer, bridge rectifier and stabiliser IC, for instance). LEDs D5...D8 are connected in series with the supply to give a ready indication which aerial has been switched in.

Depending upon the position of switch S1, the forward bias current first passes through one of the LEDs, subsequently through one of the chokes L1...L4, then through the relevant PIN diode (D1...D4) and finally to earth via choke L5 and resistor R1. This latter resistor determines the value of the current; at 680 Ω , as in figure 5, the current is 15 mA which is sufficient to ensure reliable switching of the diodes and satisfactory lighting of the LEDs.

Capacitors C1...C4 and C9 are necessary

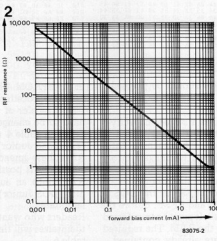

Figure 2. Characteristic of RF resistance vs forward bias current of a typical PIN diode.

to prevent DC appearing at the input and output of the circuit. Chokes L1...L5 prevent the HF signal leaking to earth via the power supply line. Capacitors C5...C8 decouple the power supply line for HF. Resistors R2...R5 ensure that the anodes of the diodes not in use are earthed so that mixing of the various aerial signals is impossible.

Construction

In view of the small number of parts, the construction of the electronic aerial switch is a fairly simple matter. The only point which needs watching is that all wiring must be kept as short as possible to ensure satisfactory operation.

Chokes L1...L5 can be wound on a ferrite bead: using enamelled copper wire of 0.3 mm diameter, two turns will suffice for UHF and five for VHF inputs. It is, of course, possible to buy them ready-made: 1 μ H is required for UHF and about 5 μ H for VHF.

The circuit has been designed for aerial input impedances of 50...75 ohms. Isolation between the various inputs is not less than 30 dB. Although the loss caused by switch S1 is minimal, the PIN diodes will deteriorate the noise factor of the receiver a little, but this will not be more than 1 dB.

3



83075-3

electronic aerial switch
elektor june 1983

Figure 3. Principle of PIN diode switch.

4

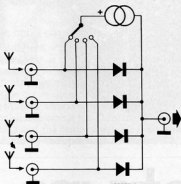

83075-4

Figure 4. Aerial switch using PIN diodes. With the use of a 4-position switch and a power supply, one of the diodes can be switched on as required.

5

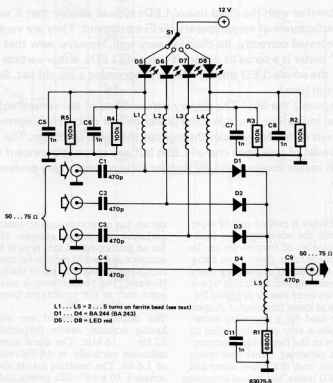

L1...L5 = 2...5 turns on ferrite bead (see text)
D1...D4 = BA 244 (BA 243)
D5...D8 = LED red

83075-5

parts list

Resistors:
R1 = 680 Ω
R2...R4 = 100 k

Capacitors:
C1...C4,
C9 = 470 p ceramic
C5...C8,
C11 = 1 n ceramic

Semiconductors:
D1...D4 = PIN diode
BA 244
D5...D8 = LED,
red, 5 mm

Chokes:
L1...L5 = see text

Miscellaneous:
S1 = switch, 1-pole,
4-way
aerial input and
output connectors

Figure 5. Complete circuit of the electronic aerial switch. LEDs D5...D8 indicate which aerial has been switched in.

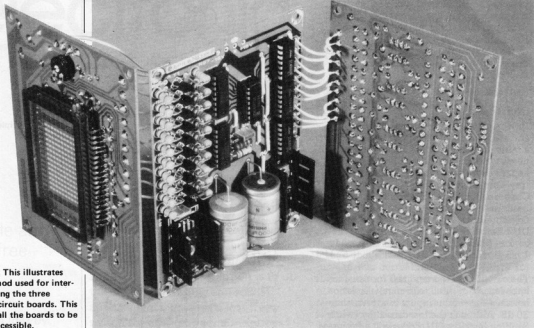

Photo 1. This illustrates the method used for interconnecting the three printed circuit boards. This enables all the boards to be freely accessible.

spectrum display

a graphical
frequency
spectrum
display

We are all familiar with the usual line-o'-LEDs type of display that is so beloved by the manufacturers of contemporary Hi-Fi equipment. They are very pretty and, if interpreted correctly, do their job very well. However now that every 'solid state' meter is a series of different-coloured LEDs, either vertical or horizontal, the whole 'LED display' theme is becoming a bit old hat. But where do we go from here?

This article points the way! The display here consists of ten vertical columns providing an indication of not just the power output of the Hi-Fi system but the peak levels of ten frequencies throughout the audio spectrum. The display does not consist of row upon row of LEDs but one special fluorescent display matrix. This makes construction far simpler and provides a very professional appearance.

A spectrum display is really a sort of super VU meter with the advantage that peak values for a number of frequencies can be seen in a graphical form. Apart from being aesthetically appealing it can be very useful. A problem with magnetic recording tape is that it saturates more readily at higher frequencies than at lower frequencies. A spectrum display used for a recording meter would thus give a very good indication of exactly where in the frequency spectrum the peaks are occurring. Other uses spring readily to mind, such as a power meter and, of course, a VU meter, but its real attraction will be... what is it... a fairly useful something to look at!

At this point it must be stated that the

circuit has no pretensions to being a high performance spectrum analyser. The circuit for an instrument of this type is far more complex and would require far more critical components than are used in the design here. However, the performance is surprisingly good and, as the prototypes proved, is accurate to about 5%.

The display consists of ten columns having nominal centre frequencies of 32 Hz... 16 kHz. The signal strength is indicated vertically in 14 discrete steps of 1.4 dB. The resulting matrix therefore contains $10 \times 14 = 140$ points and could be constructed using 140 LEDs. However, the current consumption of a display matrix of this size using LEDs would be fairly

10 frequencies:
32-63-125-25-500-1 k-2 k-
4 k-8 k-16 kHz
Amplitude read-out in
14 discrete steps of 1.4 dB
Input sensitivity:
90 mV... 1.8 V
Input impedance:
47 k

high. Construction would be fraught with a few problems and the overall finished appearance would leave a lot to be desired. All these disadvantages are overcome by the use of a fluorescent display that contains the correct number of picture dots (or pixels) and, of course, one such 'animal' does actually exist - the DM4Z from Futaba. With 10 vertical columns of 14 pixels, it could almost have been made to order ...!

Design fundamentals

The block schematic of figure 1 illustrates the basic sections of the circuit. The incoming signal is divided into 10 frequency bands by the 10 band-pass filters with the centre frequencies mentioned earlier. The output of each filter is followed by a simple rectifying circuit consisting of a diode and a capacitor and then fed to a 10 into 1 multiplexer. The multiplexed output signal is fed to 14 comparator stages which also act as the driver stages for the 14 horizontal lines of the display matrix. A 1 into 10 multiplexer drives the 10 columns of the matrix. Both the multiplexers are clocked with a common clock signal to ensure that they are always exactly in step with each other. This means that the 10 into 1 multiplexer always

connects that filter to the comparator stages that correspond to the column selected by the 1 into 10 multiplexer. Therefore a number of pixels in each column will light depending on the conditions of the 14 outputs of the comparator stages. In essence, the number of pixels lit in a column will depend on the voltage level across the capacitor in the rectifier stage following the filter corresponding to that column.

So far so good, but the circuit itself is not quite that simple because we now require 10 band-pass filters, 10 rectifier circuits, 2 multiplexers and their clock oscillator, 14 comparator stages, a power supply and, of course, the display itself. However, before despair sets in, construction is vastly simplified by the use of printed circuit boards.

The band-pass filters

As only ten centre frequencies are to be displayed it is not necessary for the band-pass filters to have very steep slopes. This is definitely an advantage because only the simple active filter circuit shown in figure 2 is required. This is a filter with multiple path feedback in which the Q factor, the amplification and the centre frequency can each be selected by the choice of 3 resistors R₁, R₂

Figure 1. The block schematic diagram of the Spectrum Display. The input signal is divided into ten frequencies by means of band-pass filters, rectified and taken to a multiplexer which feeds the ten voltage levels sequentially to a comparator. The comparator drives the lines of the display while the columns are controlled by a second multiplexer.

1

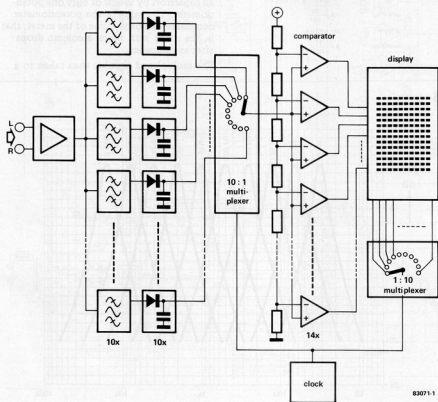

83071-1

and R3, and capacitor C. The formulae for the filter are given in figure 2. The amplification of the filter is set at 7 dB and the Q factor at about 3. No special components are used in the circuit and therefore some small deviation of the centre frequency and the Q factor can be expected but this can be ignored. The frequency response curves for the filters are shown in figure 3.

The circuit diagram

The complete circuit diagram for the spectrum display will be found in figure 4. At first sight it may appear to be rather complex but, as we already know, most of it is just repetition.

The input circuit is formed by op-amp A1

2

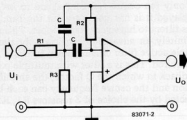

Figure 2. This shows the circuit of the active band-pass filter. The centre frequency, the amplification and the Q-factor can all be set separately by the correct values of resistors R1 . . . R3 and capacitor C.

$$\begin{aligned} \text{centre frequency: } f_0 &= \frac{1}{2\pi C} \sqrt{\frac{R1 \cdot R3}{R1 R2 R3}} \\ \text{gain at } f_0 &= -A_0 \frac{R2}{2R1} \\ \text{Q factor: } Q &= R2 C f_0 \\ \text{bandwidth: } B &= \frac{1}{R2 C} \end{aligned}$$

which is arranged as a mixer-amplifier. Both the left-hand and the right-hand signal are connected to the related input terminals: the output of the op-amp then contains the sum of these two signals. It is, of course, possible to connect a mono-signal to one of the two input terminals; the other terminal can remain 'open'. The amplification of A1 can be adjusted between 0 dB and 13.5 dB. At maximum amplification, the input sensitivity of the stage is 90 mV.

The output of A1 is connected to the inputs of the ten band-pass filters, A2 . . . A11. The centre frequency of filter A11 is about 32 Hz, that of A10 around 63 Hz, and so on, until that of A2 is around 16 kHz. The output signals of the filters are rectified and smoothed by diodes D1 . . . D10, resistors R34 . . . R43 and capacitors C23 . . . C32 respectively.

The 10-to-1 multiplexer which follows is a 'discrete' design consisting of ten analogue switches ES1 . . . ES10. These are driven by the output of counter IC13, of which more later. The outputs of all analogue switches are connected together and terminated in R45 and potentiometer P2. The total value of R45 plus P2 determines the discharge time of the capacitor which at any one moment is connected to R45 and P2 via one of the switches. Each of these capacitors could have been given its own discharge resistor, but in this way a saving of nine resistors is made and, in addition, it has become possible to see the discharge time of all capacitors by means of only one potentiometer. The value of the potentiometer determines the decay time of the meter, that is, the speed with which a column drops after an indication.

The multiplexed signal is then taken to a

3

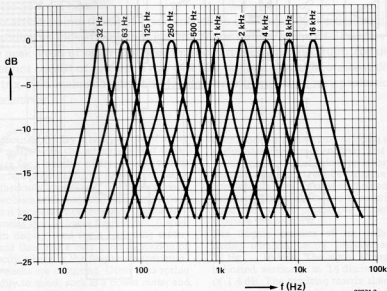
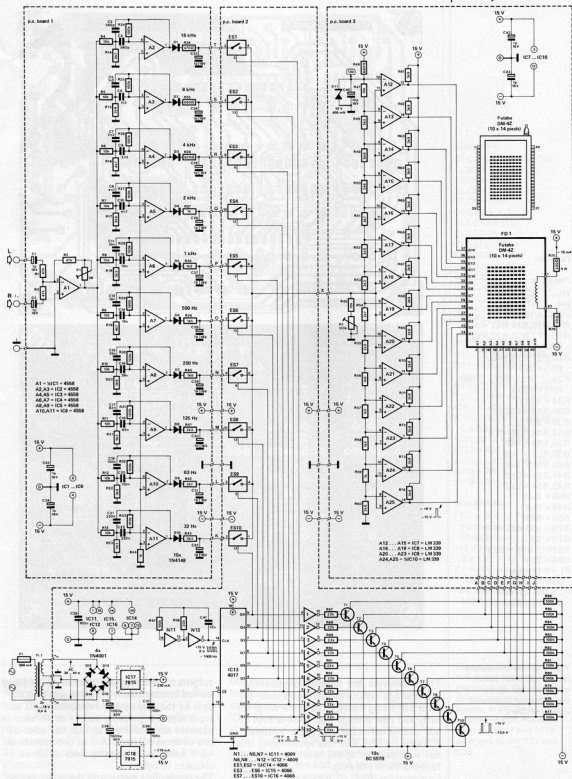

Figure 3. The frequency characteristics of the ten band-pass filters.



14-stage comparator, A12 ... A25. The voltage at the non-inverting input of each op-amp, that is the multiplexed signal, is compared with a reference voltage at the inverting input of the amplifier. The reference volt-

ages are derived from 10 V DC which in turn is derived from the 15 V supply by means of R46 and zener diode D11. The reference voltages for the op-amps are obtained from a voltage divider consisting of R47 ... R60.

Figure 4. The complete circuit diagram of the Spectrum Display. Which parts of the meter are located on each of the three boards is indicated by the hatched line.

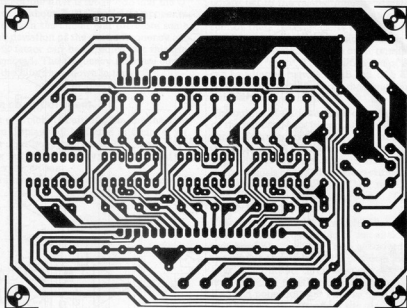

Parts list

Resistors:

- R1 ... R3 = 47 k
- R4 ... R13, R45, R47 = 10 k
- R14, R16, R19, R51 = 4k7
- R15, R17, R20, R22, R52, R60 ... R74 = 3k9
- R18, R21, R23, R43, R53 = 3k3
- R24 ... R33, R77 ... R86, R97 = 100 k
- R34 = 470 Ω
- R35, R46 = 680 Ω
- R36 = 820 Ω
- R37, R44, R59 = 1 k
- R38, R58 = 1k2
- R39, R57 = 1k5
- R40, R56 = 1k8
- R41, R55 = 2k2
- R42, R54 = 2k7
- R48 = 8k2
- R49 = 6k8
- R50 = 5k6
- R75 = 330 Ω /5 W
- R76 = 33 Ω
- R87 ... R96 = 22 k
- R98 = 33 k
- P1 = 1 M preset potentiometer
- P2 = 100 k preset potentiometer

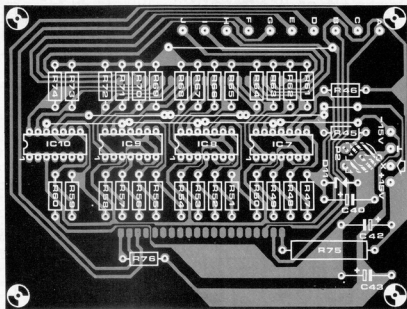

Figure 5. The component layout and track pattern of the printed circuit board for the filters and signal rectifiers.

These resistors are normal, commercial types which results in the logarithmic division not being exactly the same value for each step (the average step value is 1.44 dB, but individual steps may vary between 1.3 and 1.8 dB). For this application, it is not necessary to spend more money on high-precision resistors.

Comparators A12 ... A25 have an open-collector output which is why each of these outputs is connected to the positive supply line via one of the resistors R61 ... R74. These resistors should be 1/4 W types as their dissipation amounts to .23 W if the output voltage of the op-amp is -15 V. When no input signal is present (0 V at point X), the

outputs of all comparators are at -15 V (they are fed symmetrically). This means that all dots of the display are extinguished. If an input signal is present, one or more comparators are inhibited, so that the grids of one or more columns of dots become about +8 V causing the relative dots of those columns to light.

The controlling element in the multiplexing process is IC13 which is wired as a 'ring' counter. This means that a logic 1 travels continuously along its Q0 ... Q9 outputs at the frequency of the clock counter formed by gates N11 and N12. The '1' appearing at the counter outputs is used to select (or switch on) each of the vertical

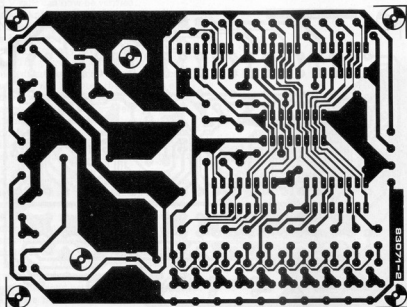

Capacitors:

C1, C2, C23 ... C34, C42,
C43 = 1 μ /16 V
C3, C4 = 560 p
C5, C6 = 1n2
C7, C8 = 2n2
C9, C10 = 4n7
C11, C12 = 10 n
C13, C14 = 18 n
C15, C16 = 39 n
C17, C18 = 82 n
C19, C20 = 150 n
C21, C22 = 330 n
C35, C36 = 1000 μ /40 V
C37 ... C39 = 100 n
C40 = 10 μ /16 V
C41 = 12 n

Semiconductors:

D1 ... D10 = 1N4148
D11 = 10 V/400 mW
zener
D12 ... D15 = 1N4001
T1 ... T10 = BC 557B
IC1 ... IC6 = 4558
IC7 ... IC10 = LM 339,
CA 339, μ A 339
IC11, IC12 = 4009
IC13 = 4017
IC14 ... IC16 = 4066
IC17 = 7815
IC18 = 7915

Miscellaneous:

FD1 = DM-4Z Futaba
fluorescent display
(Regisbrook)
Tr1 = mains transformer
2 x 15 ... 18 V/400 mA
F1 = 500 mA slow-blow
fuse
heat sink for IC17 and
IC18 (35 x 20 x 15 mm)

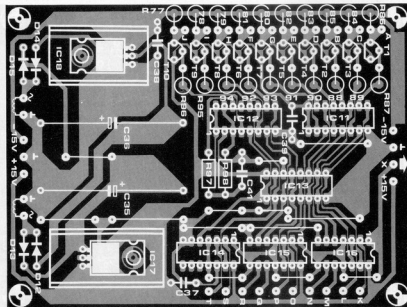

columns of the display. However, it can't do it directly since the fluorescent display is in fact switched between 0 and -15 V and some sort of interface is therefore required. This is conveniently taken care of by inverters N1 ... N10 and transistors T1 ... T10 which act as drivers and level translators.

The ring counter also drives the analogue switches ES1 ... ES10. As already explained in the description of the block schematic diagram, these connections are arranged such that at all times only the band-pass filter corresponding to a driven column is connected to a comparator circuit. Readers may remember the article on

fluorescent displays in our March issue in which it was explained that this type of display operates by means of a filament. The filament current is provided by the symmetrical power supply and limited by R75. Resistor R76 ensures a small positive potential difference between cathode filament and anode and grid which prevents unwanted lighting of the pixels.

A simple power supply is required for the +15 V and -15 V levels and for this the usual voltage regulator ICs are used, IC17 and IC18. The supply is capable of providing a current of at best 250 mA.

Figure 6. This printed circuit board contains the multiplexers, the column drivers and the power supply. It should be remembered that the heat sinks for IC17 and IC18 must not touch C37 and C38.

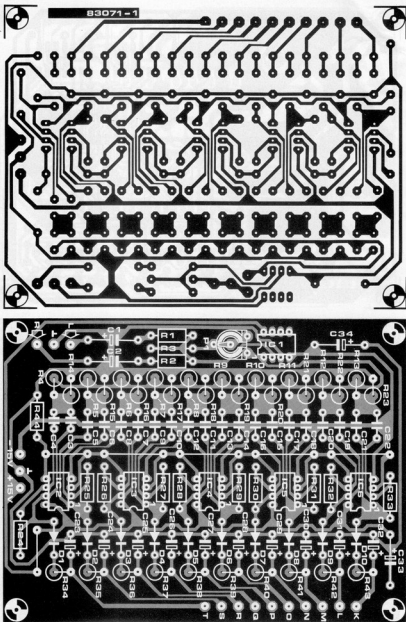

Figure 7. The ten comparators and the fluorescent display are located on this printed circuit board. Both the display and preset P2 are mounted on the foil side of the board.

Construction

The spectrum meter is constructed on three printed circuit boards as illustrated in figure 4. One board contains the filters and rectifier circuits, the second contains the power supply, the multiplexers and the level translators for the column drives, the final board carries the comparators and the display itself. Three boards were decided on in order to keep overall size down to convenient proportions. It also enables separate sections of the circuit to be used for other purposes, or indeed, further additions such as higher performance band-pass filters if desired.

Construction can be started with the com-

ponents of the power supply circuit on printed circuit board 2. ICs 17 and 18 must be fitted with heatsinks and care must be taken in their choice with regard to physical dimensions. Too large a size will find capacitors C37 and C38 hanging off the board! With just the power supply components mounted on the board, the transformer can be wired up and a check carried out.

The first point to note is that if a transformer with two secondary windings is used it is obviously important that they are wired to the board correctly. This is very easy to check by measuring the voltage across the (total) secondary winding. If the reading is about zero volts then

simply reverse the connections of one of the secondary windings. The +15 V and -15 V rails can now be verified.

The remaining components on the board and those on printed circuit board 3 can now be fitted. Resistors R77 . . . R96 are mounted vertically saving a great deal of space. The preset P2 and the display are mounted on the foil side of printed circuit board 3. It will be noted that no holes exist in the board for the display and this is quite deliberate. It effectively prevents the pins of the display from protruding through to the component side of the board and causing all sorts of untoward happenings! Even so, mounting the display will present no problem.

The small nipple (via which the display is evacuated during manufacture) must be located at the side of potentiometer P2. The display is then held in position and one or two pins are soldered to the relative positions on the boards. If the display appears to be sited correctly, all other pins can be soldered. After that, the connections between boards 2 and 3 can be made. The interconnections between A . . . J on both boards are made with short lengths of flexible wire; those between 15 V, -15 V, I and X can be made with somewhat longer pieces of wire (6 . . . 7 cm). The boards can then be folded apart to give good accessibility (see photo 1).

The time has now come to check whether the display will light correctly. First, P2 is set to maximum (100 k) and then a 10 k potentiometer is connected between +15 V and 0 V. The slider of the potentiometer is connected in turn with terminals K . . . T (in that order). With the slider connected to K, the left-hand column of the display should begin to light when the potentiometer is adjusted for a higher voltage; once the voltage is high enough, all 14 dots of the column should light. When this is found to be working correctly, the other columns should be checked in a similar fashion. When all columns are found to be functioning correctly, it indicates that the display-drive, the multiplexers, the clock and the comparators are in good working order.

The remaining board, PCB1, can now be completed. The capacitors C23 . . . C32 and resistors R4 . . . R23 and R34 . . . R43 are mounted vertically. Then terminals K . . . T, +15 V, I and -15 V are interconnected: the last three preferably by somewhat longer pieces of wire to enable to boards to be 'opened' as in photo 1.

The complete set of boards can now be fitted together like a double sandwich by means of 4BA threaded rods, nuts and spacers as shown in photo 2.

Finally . . .

. . . some further points to note. The circuit contains two preset potentiometers, aptly labelled P1 and P2! The first is used to adjust the input sensitivity while P2 controls the decay time of the display. Preset P2 was deliberately positioned just above the display (and on the foil side of the board) to enable the decay time to be

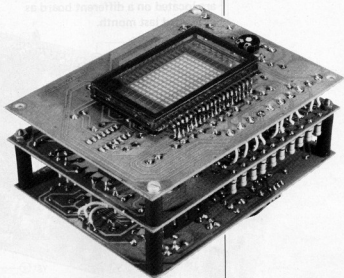

Photo 2. The final construction of the Spectrum Display is illustrated here. It is also possible to mount the display remotely if desired.

adjusted through a small hole in the front panel above the display window. It is also, of course, possible to use full size potentiometers in place of the presets and mount them on the front panel. It is strongly advised that a screen of some sort is used for the display window. A piece of green perspex for this would probably present the best appearance. In the event that the completed Spectrum Display is too large to be fitted into a desired space, it is possible to mount the display remotely from the circuit boards. An appropriate length of 26 way ribbon cable would be ideal for the interconnection between the boards and the display.

Where is the input connected to? If possible it would be best to use the tape - record - monitor output of the preamplifier where the output level remains fairly constant and is independent of the various controls of the preamplifier. This has the advantage that the input sensitivity of the Spectrum Display need only be set once. If the signal is taken from the preamplifier outputs to the power amplifier stage (the so-called pre-power link) it will be necessary to adjust P1 every time the volume level is altered. Not a happy situation!

It is, of course, possible to build a 'stereo' Spectrum Display. This simply consists of two independent Spectrum Displays and uprating the transformer to an 800 mA type. The two circuits are then fed from the two channels of the tape record output of the preamplifier.

Now for Quadrophonic . . . but that's going a bit too far!

Following the description of the complete Maestro remote control and the construction of the transmitter in our May issue, we continue with the construction, fitting and adjustment of the receiver. Virtually the complete receiver is contained on a double-sided printed circuit board; only the two displays and associated drive circuits are located on a different board as explained last month.

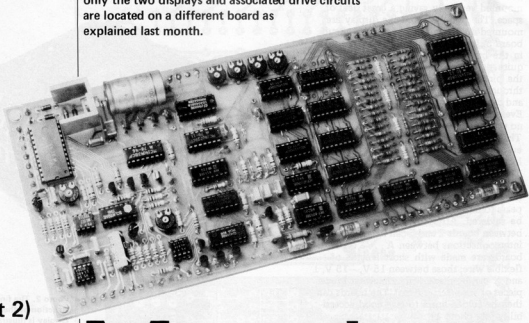

(part 2)

Maestro

the
receiver board

The receiver board is not small, but in view of the complexity of the circuit that is not unexpected: after all, it contains 29 IC's, 15 transistors, 9 diodes and a fair number of resistors and capacitors. The board is shown in figure 1. It is advisable to check the through-plating of the holes (with a resistance meter) before any other work is commenced, because any faults are virtually impossible to find once the board has been soldered.

Construction

After the board has been checked thoroughly, the components can be mounted. All IC's should be fitted in good-quality sockets.

Capacitors C22 and C23 are mounted vertically. The two 7-segment displays and associated driver circuits, resistors and decoupling capacitors are located on the display printed circuit board, the design of which was dealt with in last month's issue. As explained last month, IC14 can be omitted if the 'extra' functions are not required. If this is the case, IC15, T7... T10, T15, R42, R44... R50, D8... D11, and half of the keyboard for the transmitter (or the 'function select' key) can also be left out. Where T15 would have been located a jump wire must be soldered between the emitter and collector connections.

In part 1 it was described how the display

board should be fitted behind the front panel. This board can be connected to the receiver board by an 11-way ribbon cable. The LEDs are connected to the printed circuit board by ordinary single-core insulated wire; D4... D7 have a common cathode connection, D8... D11 a common cathode connection to the + line, and D12... D15 have a common anode connection. The volume counter on the receiver board should be pre-programmed by four jump wires. Note that as this is a CMOS device, none of its inputs should be left floating as this might cause the device to burn out. The receiver diode, which is located behind the receiver window, is connected to the board by two short pieces of wire.

If the power outputs to other equipment are to be used, three relays, Re1... Re3 are needed to switch the mains supply. Diodes D_x , D_y and D_z should be connected directly to the coils of the relays. The relays can be fitted in the case of the Maestro or in the equipment to be powered (where they continue to be driven by the low power signals from the Maestro). The maximum permitted current per relay is 100 mA.

As regards the tape recorder connections, Q1... Q7, there is no cut-and-dried universal layout that will suit every tape recorder. Some tape recorders work by setting some lines to ground, while others connect the relevant lines to +24 V. So there is only one

A word to Prelude constructors:
Printed circuit board designs for the buffer stages described in our May issue will be published in the July/August 'Summer circuits' issue.

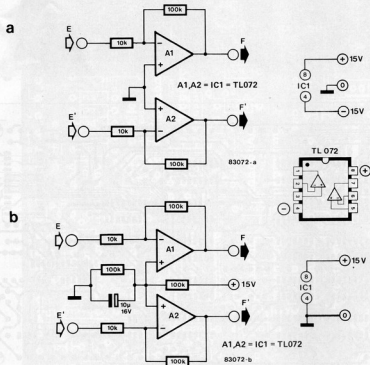

Figure 1. If the Interlude is used without the Prelude, an extra stage of amplification is required. The circuit of such a stage for use with a 15 V symmetrical supply is shown in 1a; in all other cases the circuit of 1b should be used.

answer to this problem: have a look at the circuit diagram of the tape recorder which is to be controlled and see how each particular function (play, fast forward, record, and so on) is controlled. It may be necessary to design a small interface between the Maestro and the tape recorder. Note that the Q outputs are all logic 1 (+15 V) when the corresponding key is pressed and that these outputs can only deliver a few milliamperes. Finally, a connector is needed for linking the receiver with the Interlude pre-amplifier. This connector must have at least 9 pins and the sensible thing to do is to use the same kind as is used for the Prelude. The connector is fitted at the rear of the Maestro case and a 9-way ribbon cable used to link the Prelude and Maestro.

Adjustment

Before the Maestro can be used, a few potentiometers must be preset. After switching on the mains, press the 'on' button to make sure that the unit is not on stand-by. To tune the receiver to the transmitter frequency first set potentiometers P1 and P2 to their mid-positions. Use the remote control to increase and reduce the volume. Turn P1 slowly until a position is found where the display correctly follows the operations of the push buttons (that is, the count on the display increases or decreases immediately the volume up or down

button is pressed). Then, watch LED D9 and while pressing the 'power 1 on' and 'power 1 off' buttons alternately, adjust P2 such that the LED reacts properly to which button is pressed.

Next, the output voltages of the D/A converters must be set. Connect the Maestro to the Prelude/Interlude and set potentiometers P3...P6 to their minimum positions. Then set all counters - volume, balance (tone) high and low - to 99 after which the remote control should not be touched until the adjustments have been completed. Connect a voltmeter between test point TP on the Interlude board and output H of the Maestro. Adjust volume control P3 slowly until the potential difference between TP and H is 0 V. Similar adjustments are made with the voltmeter between TP and outputs K, M and L and adjusting balance control P4, (tone) low control P5 and (tone) high control P6 respectively. Once these adjustments have been made, the voltages between each of these outputs and ground should be about 5.4 V. The Maestro can then be boxed up.

Interlude and Maestro

Some readers may want to use the Maestro and Interlude, but not the Prelude, which is, of course, possible but a small circuit will then have to be added on the Interlude

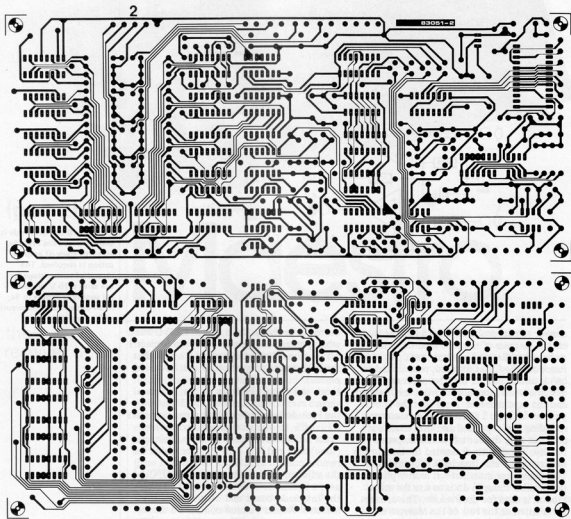
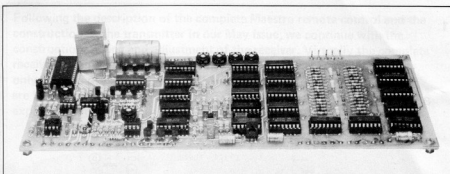

Figure 2. The printed circuit board for the receiver is double-sided with plated-through holes. Its size is an unavoidable consequence of the large number of components used.

printed circuit board, provided that the power supply can additionally deliver 15 V at 100 mA.

As the Interlude is a unity gain amplifier, an additional voltage gain of 10 is required to obtain an output of 1 V for an input of 100 mV. A suitable circuit for use with a symmetrical supply of ± 15 V is shown in figure 1a; if such a supply is not available, the circuit of figure 1b must be used.

The additional amplifier stage is connected between points E and F and E' and F' on the printed circuit board after resistors R23 and R23' have been removed and resistors R17,

R17', R24 and R24' have been replaced by jump wires. The op-amps can be type TL 072, TL 082, RC 1458, RC 4558.

The inputs for tuner, tape and auxiliary can be connected directly to the input bus. Points D1 . . . D4, H, K, L and M are connected to the Maestro by a suitable ribbon cable.

The Interlude and Maestro can be built into one common case but that is a matter of personal choice.

That finishes the construction and pre-setting of the Maestro; all that remains is to enjoy it!

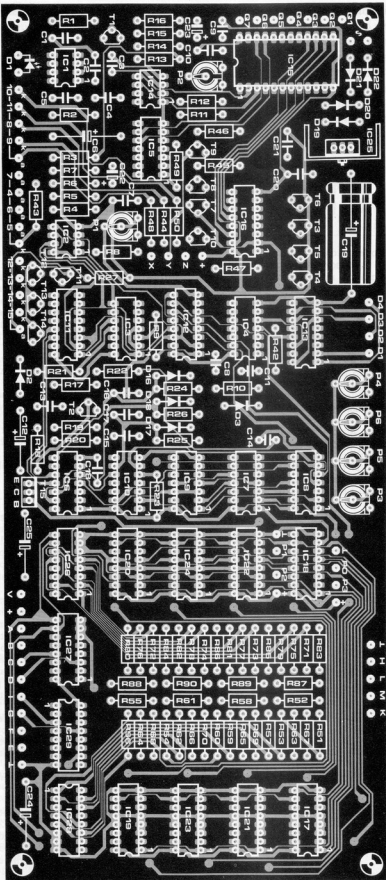

Parts list: Receiver

Resistors:

- R1, R9, R10, R11, R17,
R19, R22, R23 = 100 k
R2 = 82 k
R3 = 560 Ω
R4 ... R7, R13 ... R16,
R27, R43, R44,
R48 ... R50 = 1 k
R8, R12 = 47 k
R18 = 560 k
R20 = 1 M
R21 = 4k7
R24 ... R26 = 10 M
R42 = 22 k
R45 ... R47 = 10 k
R51 ... R62 = 1 M/1%
R63 ... R66 = 499 k/1%
R67 ... R70 = 249 k/1%
R71 ... R74 = 200 k/1%
R75 ... R78 = 100 k/1%
R79 ... R82 = 49k9/1%
R83 ... R86 = 24k9/1%
R87 ... R90 = 15 k
P1, P2 = 100 k preset
potentiometer
P3 ... P6 = 5 k (4k7)
preset potentiometer

Capacitors:

- C1 = 47 n
C2, C4, C15, C21 = 100 n
C3 = 82 p
C5 = 2n2
C6 = 47 μ /25 V
C7, C10 = 22 n
C8, C14 = 22 p
C9, C11 = 100 p
C12, C24, C25 = 10 μ /16 V
C13 = 470 n
C16 ... C18 = 220 n
C19 = 1000 μ /40 V
C20 = 330 n
C22, C23 = 1 p/16 V

Semiconductors:

- D1 = BP 104
D2, D3,
D16 ... D18 = 1N4148
D4 ... D15 = LED red
D19 ... D22,
D_x, D_y, D_z = 1N4001
T1 = BC 560
T2 ... T6,
T8 ... T10 = BC 547B
T7, T11 ... T14 = BC 557B
T15 = 8D 679
IC1 = SL 480
IC2 = ML 926
IC3 = 4011
IC4 = 4072
IC5 = 4002
IC6 = 4093
IC7 = 4001
IC8, IC9 = 4025
IC10 = 40106
IC11 = 4556
IC12 = 4555
IC13 = 4042
IC14 = ML 927
IC15 = 4514
IC16 = 4043
IC17 ... IC24 = 4510
IC25 = 7815
IC26 ... IC29 = 4052

Miscellaneous:

- Tr1 = transformer,
15 V/0.8 A secondary
Heatsink for IC25
3 x relays, 12 ... 15 V,
100 mA max.

from an idea by
L. Heylen

video effect generator

box of tricks
for video
enthusiasts

The rapidly growing popularity of Video has resulted in an ever increasing string of requests to provide articles for the new band of Video enthusiasts. It is an even more interesting area now that the price of a good video camera is reaching more affordable levels. However, it is a relatively new field and good ideas and circuits take time to formulate.

The article here is pointed in the right direction and is aimed at readers who find an interest in making their own video recordings. The circuit enables certain video tricks or special effects to be used in a video recording and provide an extra dimension that can make a lot of difference.

It is not easy to describe the effects which can be obtained with this generator. It gives the pictures a more 'graphic' character as it were. But that is not the only thing. Depending upon how the generator is adjusted, the effects achieved are reminiscent of trick photography.

What is the idea behind this box of tricks? Well, mainly the dividing of the normally continuously variable brightness of the screen into four fixed values of brightness. The result is, therefore, not just a black and white picture, but additionally two grades of grey, analogous to a digitalisation of the brightness and contrast.

A second feature, which is virtually forced as shall be seen later in the article, is the separate adjustment of brightness and colour saturation. The brightness and colour information are split in the early stages and combined again in the later stages of the circuit; the combining can be achieved in a proportion which is under the control of the operator. By choosing deliberate proportions, grotesque effects are obtained. An important remark before technical details are gone into; the input and output of the generator are tuned to standard video signals and it is therefore possible to insert it anywhere in the video chain.

Operation

As usual, the principle of the circuit is best explained with the aid of a block diagram as shown in figure 1.

The video input signal is split into two parts:

Figure 1. Block schematic diagram of the video effect generator. The information contained in a video signal is dissected into information regarding the brightness, information as to colour and information about the synchronisation. After the brightness information has been processed, the three bits of information are re-combined in two mixer stages.

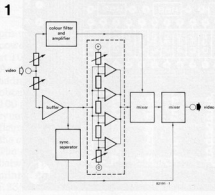

one part is passed to a colour filter and amplifier, which will be dealt with a little further on, and the other to a four-stage comparator via a buffer. The comparator arranges the (pre-settable) splitting of the brightness into four levels. The processed signal is then passed to a mixer which re-combines the colour and brightness information.

At first sight it may appear unnecessary to filter out the colour information, only to add it again at a later stage, but there is a good reason for this. If the colour were not filtered, the four-stage comparator would also affect the colour information. The sync signal is protected likewise for the same reason: a sync separator takes the sync signal from the buffer and applies it to a second mixer stage where it is re-combined with the rest of the signal.

Circuit description

The blocks shown in figure 1 can be recognised in the circuit diagram of figure 2: A1 is the buffer with input derived via LEVEL control P1 and its output applied to comparators K1...K4. The comparators divide the originally continuously variable brightness into four fixed levels.

The sync separator is formed by comparator K5. Clamping diode D1 ensures that the output of A1 is always positive with respect to the reference voltage of comparator K5. The sync signal lies roughly in the bottom quarter of the video signal and is separated from it by K5. Diodes D2...D5 and potentiometers P3 and P5 form the preset reference voltage supply for the four-stage comparator.

Transistor stage T3 is the colour filter and amplifier; its input level is set by potentiometer P2 and its output is taken to the inverting input of mixer A2. This stage filters and amplifies frequencies in the range 4.43 ± 1 MHz. The amplification is necessary to ensure retention of the information of the original signal.

The four-level output of comparators K1...K4 is also applied to mixer A2 and there mixed with the colour signal from T3. The output of A2 is applied to a second mixer, T2, together with the sync signal from comparator K5.

The output of the generator is best connected

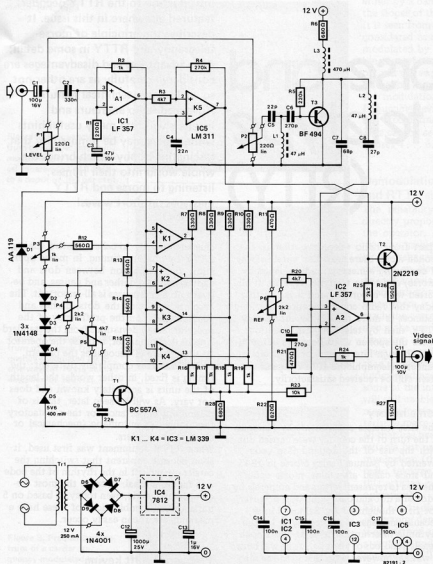

Fig. 2. Circuit diagram of the video effect generator. The change of continuously variable to (four) fixed level brightness control takes place in comparators K1 . . . K4. Synchronisation signals are separated by K5, while T3 separates and amplifies the colour information. The complete video signal is reconstituted in mixers A2 and T2.

to the video input of a television receiver, but if such an input is not available, it can be fed to the aerial input via a VHF/UHF modulator.

Adjustment

The functions of the various potentiometers are;

- P1 = setting of the input level (sensitivity);
 P2 = setting of the colour saturation;
 P3 and P5 = setting of the reference voltage for comparators K1 . . . K4;
 P4 = setting of the reference voltage for comparator K5;
 P6 = setting of operating point of mixer A2.

1. Set all potentiometers to their mid position.
2. Connect the generator to the television receiver and switch on the mains supply. The input signal should preferably be a test card.
3. Adjust P4 until the picture on the

television screen is still.

4. Set the reference voltage for K1 . . . K4.

If four levels are not attainable, the input signal is too weak and the input sensitivity should be increased by P1. If the picture quality is poor, this may be due to overloading: the input level should then be reduced by P1.

5. Increase the input signal by means of P1 and adjust P6 to that position where the largest possible input signal can be processed without undue distortion.

6. Finally, set the required colour saturation with P2.

NOTE: After every change of input sensitivity, it is recommended to readjust the sync level with P4.

morse and radio teletype (RTTY)

all about
those dots,
dashes
and pulses

Apart from radio telephony, that is, the spoken word, there are other 'wireless' ways of conveying a message: radio telegraphy (morse) and radio teletype (RTTY). It all started with telegraphy and it is still true today that radio communication over long distances is more reliable by morse and RTTY than by telephony: in situations where the spoken word becomes unintelligible through interference or other circumstances, telegraphic or RTTY signals can often still be received satisfactorily.

Some history

The first wireless experiments by Marconi at the turn of the century were carried out with the use of the dot-and-dash code invented by Samuel Finlay Morse in 1843 and since called after him, morse code. The idea to represent letters and numerals by a dot or a dot-and-dash code was, however, not first thought of by Samuel Morse, because messages were conveyed by the rhythmic interruption of light and smoke signals hundreds of years before he was born. It was he, however, who first used the idea in telegraphy by wire and it was also he who devised a usable alphabet and number system in morse code (see figure 12). Radio teletype was born from the need for greater speed in the conveying of messages and that for decoding and typing of received message automatically; morse was not really suitable to meet these needs. But then, morse was intended for hand-operation, easy recognition and to be learnt fairly quickly by operators; clearly, Samuel Morse did not consider automation. In teleprinter codes, unlike the Morse code, each combination of characters forming a letter, numeral, punctuation mark and so on, is of the same length as measured in units (often called bits but this can give rise to confusion with the binary digit) or in milliseconds of time.

The difference between morse telegraphy and RTTY

The main difference between morse telegraphy and RTTY lies in the timing: morse is

This article gives a theoretical introduction to the RTTY decoder featured elsewhere in this issue. It describes the principle of morse-telegraphy and RTTY in some detail; their advantages and disadvantages are considered carefully as are other not so well-known technical features. Advanced radio amateurs and listeners will find many useful hints while others may be tempted by that fascinating hobby which brings the whole world into their homes: listening to morse and RTTY messages on short waves!

characterized by so-called relative timing, RTTY by absolute timing. In morse operation, the proportion between dots and dashes, between dashes and pauses, and between dots and pauses is all-important. The absolute length of the dots, dashes and pauses depend on the proficiency of the operator. Small deviations from the standard lengths do not matter, because the operator 'at the other end' recognises the pattern. In RTTY this is completely different: the timing is fixed, in other words, the length of the units is accurately known and does not vary. As will be seen later, this is of paramount importance for the satisfactory functioning of automatic (mechanical or electronic) decoders.

When RTTY equipment was first used, it soon became apparent that switching the carrier on and off in the rhythm of the code was far from ideal. Because the most frequently used code, even today, is based on 5 units and all combinations of these have a meaning, errors can easily occur.

Frequency shift keying

To eliminate as many of these errors as possible, frequency shift keying (FSK) was introduced. In this system the carrier frequency has two values: the first (normally higher) frequency is called a mark and represents logic 1; the second (normally lower) frequency is called a space and represents logic 0. The difference between the two frequencies is called the frequency shift.

Frequency shift keying can be considered as amplitude modulation of a carrier, where the modulating signal is a square wave and the depth of modulation is 100 per cent. A square wave consists of a sinusoidal fundamental and harmonics, in which the ratio of the harmonics depends upon the duty cycle of the square wave. A symmetrical square wave has only odd harmonics. The frequency spectrum of a carrier amplitude modulated by a symmetrical square wave to a depth of 100 per cent is shown in figure 1. It is immediately clear that steps have to be taken to limit the bandwidth. In practice this is achieved by connecting an

Figure 1. Frequency spectrum of a carrier amplitude-modulated by a symmetrical square wave of 1 kHz to a depth of 100 per cent.

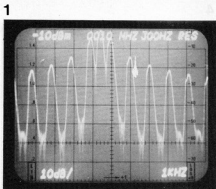

Figure 2. Frequency spectrum of a carrier frequency-modulated by a sine wave of 10 Hz at a deviation of 100 Hz.

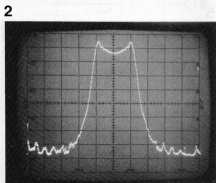
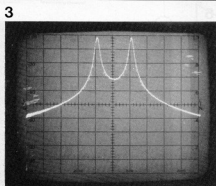

Figure 3. Frequency spectrum of a carrier frequency-modulated by a square wave of 10 Hz at a deviation of 100 Hz.



RC-filter between the key and transmitter. Transmitters with too broad a spectrum are recognisable by the key-clicks, in the rhythm of the code, just off-tune.

The spectrum of a frequency-modulated carrier is shown in figure 2. The modulating signal is a sine wave of 10 Hz and the deviation is about 100 Hz. It is evident that the greater part of the energy lies between $f_c - f_d$ and $f_c + f_d$, where f_c is the carrier frequency and f_d is the deviation. The frequency shift is twice the deviation.

What happens when the modulating signal is changed from a sine wave to a square wave can be seen in figure 3, from which it is clear that the peaks are much better defined than in figure 2. The reason for this is that the transit time from logic 1 to 0 or vice versa is very short, so that little energy is transferred in the region $f_c \pm f_d$. The slopes of the signal are, however, less steep than with sine-wave modulation, so that steps need to be taken to make the bandwidth

acceptable. This can be done in two ways: either by a band-pass filter or by rounding the slopes of the modulating signal. It is seen from the above that FSK can be considered as a carrier which is frequency modulated by a square wave or as a combination of two carriers which are switched on and off sequentially. The second consideration is perfectly acceptable as long as the modulation index (the ratio of the frequency deviation to the frequency of the modulating signal) is greater than 1. This can be seen from the illustration in figures 4... 6.

Demodulation of morse telegraphy and RTTY signals

The reliability of morse telegraphy is directly proportional to the proficiency of the operator. An experienced person can 'copy' a garbled message which would be incomprehensible to a novice, and in this respect an electronic circuit can be considered a novice. The human brain, with its enormous store of information, can, even when there is doubt, more often than not reach the correct conclusion. Human beings also make use of an important property of language: redundancy, which means that there is normally more information available than is necessary to come to a decision or understanding. In other words, even when some of the information is missing, the rest will still enable us to understand the original message perfectly. These human characteristics make morse telegraphy, in spite of all that has been said, the cheapest and most reliable but one method of wireless communication (the repeat request - RRQ - radio teletype system described later in this article is more reliable than morse operation).

The block diagram of a typical morse telegraphy demodulator is shown in figure 7; it consists of a band-pass filter, an amplifier, a rectifier and a trigger. Automatic gain control (AGC) is also often incorporated. The circuit of such a demodulator presents certain difficulties. The filter should have a pass band of the order of 100 Hz and filters with such steep-sloped characteristics are fairly complicated and thus costly. The most suitable filters are built from delay elements. The delay, that is the time taken by the signal to pass through the element, is frequency dependent. At the centre frequency of such a filter each element delays the signal by one half cycle. After passing through two elements, the signal at that point is in phase with the input signal and if these are added together, there is effective amplification of the original signal. At frequencies where the two signals are 180° out of phase, adding them together would cause effective attenuation. Thus, by careful choice of the delay elements, any desired selectivity can be achieved. The great advantage of this technique is the ability of the delay elements to block spurious signals effectively; the signal is gradually 'built up' in the filter, whereas unwanted signals are too short for any build up to take place. As the signal takes a finite

time to pass through the filter, its frequency should not change during this time, otherwise the aimed-for phase relationship will not be achieved. These filters will soon be available in digital form as integrated circuits.

For the detector a diode circuit will suffice if the filter has good selectivity, although synchronous demodulation is better because of its greater immunity to interference. Such demodulation is normally effected by a phase-locked loop (PLL) which has a dynamic characteristic of not less than 30 dB: this makes AGC superfluous.

The trigger circuit must differentiate between signals of high and low logic levels. To reduce the effects of spurious signals, the detector output should be integrated. The circuit will only trigger if the signal lasts long enough to cause a logic 1. The use of a voltage or current controlled integrator enables the integration constant to be defined by a microprocessor on the basis of the speed of the received signal.

Frequency or amplitude modulation?

RTTY was initially taken as consisting of frequency-modulated (FM) signals and was therefore demodulated in a discriminator. It was argued that this would result in an improvement of the output signal exactly as FM broadcast reception sounds much better, in general, than AM. Nowadays, this argument is accepted by only a small minority.

In the high-frequency bands (1.6... 30 MHz), propagation phenomena occur which affect the path times of a transmission (one path, for instance, is reflected by the E layer of the ionosphere, another by the higher F layer). One of the effects of two waves of the same signal traveling by two different paths to the receiver is interference fading. Another effect is that of selective fading which occurs when some frequencies are more attenuated than others due to phase-shifting.

FM signals suffer quite badly from these effects and this is worsened by increasing the frequency deviation, which is often done because FM theory is that the gain in signal to noise ratio is directly proportional to the frequency deviation/ baud rate ratio.

Photographs taken from a spectrum analyzer show that, in most cases, it is more correct to treat FSK as a combination of two keyed carriers. The narrow bandwidth then depends only on the baud rate and no longer on the frequency deviation; at the same time it ensures greater rejection of spurious signals.

4

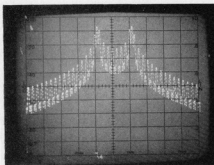

5

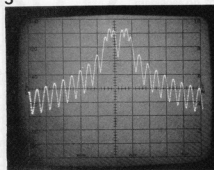

6

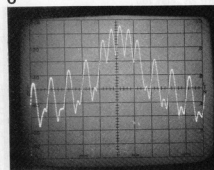

morse and radio
teletype (RTTY)
elektor june 1983

Figure 4. Frequency spectrum of a carrier frequency-modulated by a square wave of 25 Hz at a deviation of 100 Hz.

Figure 5. Frequency spectrum of a carrier frequency-modulated by a square wave of 50 Hz at a deviation of 50 Hz.

Figure 6. Frequency spectrum of a carrier frequency-modulated by a square wave of 100 Hz at a deviation of 50 Hz.

An RTTY demodulator (normally called a TU - terminal unit) continues to function satisfactorily even if one of the carriers, each of which contains the same information, disappears, due to fading, for instance. The block diagram of a typical TU for FM operation is shown in figure 8. The signal is

7

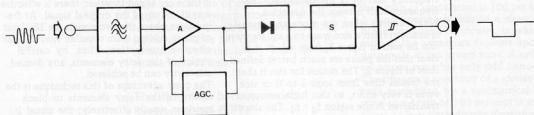
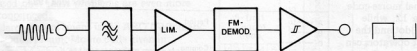

Figure 7. Block schematic diagram of a typical morse telegraphy demodulator.

8



morse and radio teletype (RTTY) elektror june 1983

Figure 8. Block schematic diagram of a typical FSK demodulator for FM operation.

9

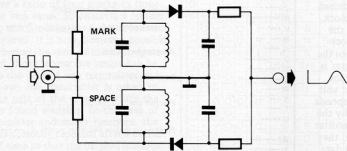

Figure 9. Circuit diagram of a frequency modulation discriminator often encountered in terminal units.

10

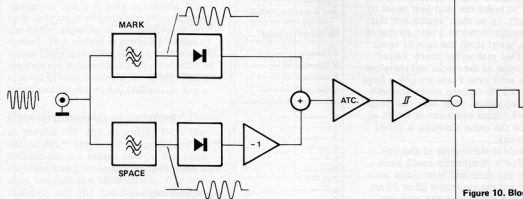
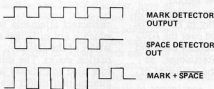

Figure 10. Block schematic diagram of a terminal unit operating as an amplitude modulation detector.

filtered, limited and then applied to a discriminator which is often of the 'true FM' type as shown in figure 9. A PLL would not be suitable because often there is no reliable relationship between marks and spaces, and the loop would then, of course, frequently be out of lock. A PLL is really only suitable if there is a guarantee that it will not get out of lock, for instance, when the frequency shift is small (85 Hz and 170 Hz are frequently used values on HF) or if operation is on VHF (30 . . . 220 MHz) where propagation is predictable.

The block schematic diagram of a TU operating as an AM detector is shown in figure 10. Separate filters are used for marks and spaces and are followed by the detectors proper. The outputs of the detectors are complementary, because when a mark is present, spaces are absent, and vice versa (see figure 11). If one of the signals disappears temporarily, the output of the adder circuit will be only half the normal value. This is, however, sufficient to drive the automatic threshold corrector (ATC) which restores the input to the trigger circuit to its correct value. The temporary absence of a mark or

11



space is therefore unnoticeable at the trigger output. As the ATC is such a simple but effective circuit (a couple of diodes, resistors and capacitors) there are few terminal units in use today without one.

Influence of the code on transmission

A code is nothing more than an agreement to process information in a certain way before conveying such information. Language is therefore a sort of code for the exchange of ideas and feelings. An important aspect of any code is redundancy. The simplest way of ensuring redundancy is

Figure 11. Idealised marks, spaces and combinations of them.

repetition. This can, however, only be used if it is possible to detect whether an error has occurred. The international morse-code characters are given in figure 12, while figure 14 shows the 5-unit Baudot and the 7-unit Moore codes. Proficient operators can often detect, and rectify, errors in the received morse-coded signals, but this is not possible with the Baudot code.

The Baudot code is the first developed RTTY code; it is an asynchronous code which means that the receiver is not synchronized with the transmitter by means of a clock. To make synchronization possible, the transmitter sends an additional, clock-controlled unit which is used to control the receiver clock. The onset of a character is indicated by a start unit which is of the same duration as a data unit. The start unit is always logic 0 and therefore corresponds to a space. The start unit is followed by the 5 data units. As the receiver and transmitter may not have kept in perfect unison, they must be re-synchronized after the last data unit: this is done by means of a stop unit. Older RTTY equipment worked at much lower speeds than their modern electronic counterpart and it was therefore perfectly acceptable to make the stop unit equal to 1.5 data unit. In modern equipment this has been brought down to 1 unit, so that all units (data, start, stop) are now of equal duration. This makes for much better synchronization of the clocks and therefore reduces the error rate. There are now a large number of RTTY stations which transmit Baudot-coded signals with only one stop unit. Asynchronous operation in which all units are of the same duration is called isosynchronous.

The baud rate is the inverse of the unit duration. For a (frequently used) baud rate of 50, the data and start units are then 20 ms and the stop units 20 or 30 ms. The baud rate itself does not give any indication of the speed with which the data are being sent. Of the 7.5 units used in Baudot (see figure 13), only five carry data and the data/unit rate is therefore $(5 \div 7.5) \times 50 = 33$ units per second.

As the possibility of an error increases with every unit, this explains why in HF traffic the Baudot code is preferred over the ARQ Moore code or ASCII (American Standard Code for Information Interchange; an 8-unit standard code for the exchange of data between machines).

One source of errors in the Baudot code lies in the so-called shift function, which is analogous to the typewriter shift from lower to upper case. The maximum number of

A ---	Period.....
B ----	Comma.....
C -----	Colon.....
D ----	Question mark, or request for repetition of a transmission.....
E ---	not understood.....?
F ----	Apostrophe.....
G -----	Dash or hyphen.....
H ----	Fraction bar...../.....
I ---	Parenthesis (before and after words)...()
J ----	Quotation marks (before and after words)....."
K -----	Equal sign.....=
L ----	Understood.....
M ----	Error.....
N ---	Cross or end-of-telegram or end-of-transmission signal.....
O -----	Invitation to transmit.....
P ----	Wait.....
Q -----	End of work.....
R ----	Starting signal (beginning every transmission).....
S ---	
T ---	
U ----	
V ----	
W ----	
X ----	
Y ----	
Z ----	
Ä (German) ----	
Á or À (Spanish-Scandinavian) ----	
CH (German-Spanish) ----	
É (French) ----	
Ñ (Spanish) ----	
Ö (German) ----	
Ü (German) ----	
1 ----	
2 ----	
3 ----	
4 ----	
5 ----	
6 ----	
7 ----	
8 ----	
9 ----	
0 ----	

characters attainable with 5 units is 32, which is not sufficient to cope with all the letters of the alphabet, numerals and punctuation marks. The shift function is therefore used to indicate when numerals and punctuation marks are coming in; when letters are coming in again, the shift has to be reset. The troubles encountered with this method are such that press agencies process all text in letters only: five for '5',

Figure 12. The International Morse code.

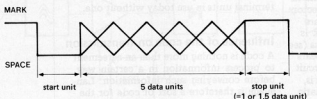

Figure 13. The composition of a Baudot character consisting of a start unit, five data units and a stop unit.

hyphen for '-', and so on. Where the alphabet in use is more extensive than our Latin-based one, these problems are even more pronounced.

A large improvement is the ARQ (Automatic ReQuest) 7-unit Moore code given in figure 14 which makes possible error detection (and eventual correction). This code which is fully synchronous (no start and stop units) gives 128 possible characters. If only those combinations are considered which give a ratio of four marks to three spaces, or vice versa, 35 characters remain available, which means that the shift function is still required. It is now, however, possible to test whether the ratio of marks to spaces is 3:4 and, if not, corrective action can be taken. In the case of one transmitter and one receiver, the transmitter is asked to repeat the part of the message where the ratio was found wanting. In the case of one transmitter and many receivers, the message is normally repeated after a certain period of time so that the original message can be compared with the repeat.

These forms of RTTY are used more and more frequently. The system where a repeat is requested is more reliable than morse operation, and it is fully automatic. The only indication of poor reception is when the buffer capacity of the receiver is exceeded. This system is gradually replacing morse communication. The system whereby message are automatically repeated after an interval of time is slowly but surely taking over from Baudot-coded traffic.

General principles of decoding

In general, the bits emanating from the demodulator are far from perfect. The deficiencies are caused by: (a) the pulse duration does not correspond to the reference time because the transmission rate has changed, and (b) spurious signals have distorted the data. The decoding algorithm must be capable of 'ignoring' these shortcomings, which is particularly difficult in morse decoders, because the unit duration in morse operation varies. The method used is to measure the bit duration, that is, to count it, and compare it with the reference time. If the measured time is greater than half the reference time, the bit is accepted as 1, if not, as 0. This method is used in the RTTY decoder described elsewhere in this issue, and also in the Elektor Baudot receiver program where it yields very good results. This further illustrates the importance of constant unit duration.

A further problem with Baudot traffic is that the start unit must be demodulated correctly. After switch-on, the receiver is ready for the transition from 1 to 0. As soon as this happens, the counting procedure starts. If during the counting procedure it should appear that for whatever reason the start unit has been 1 for more than half the reference time, a false start is assumed and the terminal reverts to stand-by. In this way, a computer will detect a false start before the start unit is finished. In morse decoding, the microprocessor must determine and memorise the shortest bit duration at the onset of the message and

14					FIGURES							ARQ 7-Unit Moore Code																		
					LETTERS																									
5-Unit Baudot Code					International	W.U.	Military	TWX	Weather																					
1	2	3	4	5	A	B	C	D	E	F	G	H	I	J	K	L	M	N	O	P	Q	R	S	T	U	V	W	X	Y	Z
0	0	-	-	-	-	-	-	-	-	-	-	-	-	-	-	-	-	-	-	-	-	-	-	-	-	-	-	-	-	-
0	-	0	0	-	-	?	?	?	3/8	⊕	-	-	-	-	-	-	-	-	-	-	-	-	-	-	-	-	-	-	-	-
-	0	0	0	-	-	:	:	:	1/8	⊖	-	-	-	-	-	-	-	-	-	-	-	-	-	-	-	-	-	-	-	-
0	-	0	0	-	-	Idf.	\$	\$	\$	3	-	-	-	-	-	-	-	-	-	-	-	-	-	-	-	-	-	-	-	-
-	0	0	0	-	-	E	3	3	3	3	3	3	3	3	3	3	3	3	3	3	3	3	3	3	3	3	3	3	3	3
0	-	0	0	-	-	Opt.			!	1/4	-	-	-	-	-	-	-	-	-	-	-	-	-	-	-	-	-	-	-	-
-	0	-	0	0	-	Opt.	&	&	&	-	-	-	-	-	-	-	-	-	-	-	-	-	-	-	-	-	-	-	-	-
-	0	-	0	0	-	Opt.	#	Stop	Stop	↓	-	-	-	-	-	-	-	-	-	-	-	-	-	-	-	-	-	-	-	-
0	-	0	0	-	-	I	8	8	8	8	8	8	8	8	8	8	8	8	8	8	8	8	8	8	8	8	8	8	8	8
0	0	0	-	0	-	J	Bell	Bell	'	✓	-	-	-	-	-	-	-	-	-	-	-	-	-	-	-	-	-	-	-	-
0	0	0	-	0	-	K	(((1/2	-	-	-	-	-	-	-	-	-	-	-	-	-	-	-	-	-	-	-	-
-	0	-	0	0	-	L)))	3/4	-	-	-	-	-	-	-	-	-	-	-	-	-	-	-	-	-	-	-	-
-	0	0	0	-	-	M	.	.	.	-	-	-	-	-	-	-	-	-	-	-	-	-	-	-	-	-	-	-	-	-
-	0	0	0	-	-	N	.	.	.	1/8	⊕	-	-	-	-	-	-	-	-	-	-	-	-	-	-	-	-	-	-	-
-	-	0	0	0	-	O	9	9	9	9	9	9	9	9	9	9	9	9	9	9	9	9	9	9	9	9	9	9	9	9
-	0	-	0	0	-	P	0	0	ø	0	ø	-	-	-	-	-	-	-	-	-	-	-	-	-	-	-	-	-	-	-
0	0	-	0	-	-	Q	1	1	1	1	1	1	1	1	1	1	1	1	1	1	1	1	1	1	1	1	1	1	1	1
-	0	-	0	-	-	R	4	4	4	4	4	4	4	4	4	4	4	4	4	4	4	4	4	4	4	4	4	4	4	4
0	-	0	-	-	-	S	'	'	Bell	Bell	Bell	-	-	-	-	-	-	-	-	-	-	-	-	-	-	-	-	-	-	-
0	-	0	-	-	-	T	5	5	5	5	5	5	5	5	5	5	5	5	5	5	5	5	5	5	5	5	5	5	5	5
0	0	0	-	-	-	U	7	7	7	7	7	7	7	7	7	7	7	7	7	7	7	7	7	7	7	7	7	7	7	7
-	0	0	0	-	-	V	=	;	;	3/8	⊕	-	-	-	-	-	-	-	-	-	-	-	-	-	-	-	-	-	-	-
0	0	-	0	-	-	W	2	2	2	2	2	2	2	2	2	2	2	2	2	2	2	2	2	2	2	2	2	2	2	2
0	-	0	0	-	-	X	/	/	/	/	/	/	/	/	/	/	/	/	/	/	/	/	/	/	/	/	/	/	/	/
-	0	-	0	-	-	Y	6	6	6	6	6	6	6	6	6	6	6	6	6	6	6	6	6	6	6	6	6	6	6	6
0	-	-	0	-	-	Z	+	"	"	"	+	-	-	-	-	-	-	-	-	-	-	-	-	-	-	-	-	-	-	-
-	-	-	-	-	Carriage Return																	0	-	-	-	0	0			
-	-	-	-	-	Line Feed																	0	-	-	0	0	-			
0	0	0	0	-	Letters																	-	-	-	-	0	0	0		
0	0	0	0	-	Figures																	-	0	-	-	0	0	-		
-	-	0	-	-	Word Space																	0	0	-	0	-	-			
-	-	-	-	-	Blank																	0	-	-	-	0	0	0		
-	-	-	-	-																		0	-	-	-	0	0	-		
-	-	-	-	-																		0	-	-	-	0	0	-		
-	-	-	-	-																		0	-	-	-	0	0	-		
-	-	-	-	-																		0	-	-	-	0	0	-		
-	-	-	-	-																		0	-	-	-	0	0	-		

Opt. = Optional

Idf. = Identification Answer Back Who Are You

Figure 14. Teleprinter codes and typical character assignments.

then ignore, or compensate for, smaller durations. The Elektor morse decoder, as well as the RTTY decoder, have an integrator which determines the integration constant by means of an adjustable current. The setting of the current value determines the width of pulses which are to be rejected. Synchronous systems depend on clocks for reliable operation: synchronisation is effected by means of special signals in accordance with internationally accepted regulations. The clock at both terminals is controlled by a stable, highly accurate quartz oscillator which is either thermostatically controlled or connected in a temperature-compensated circuit. Once synchronisation has been established, the two clocks are locked for a considerable time. The decoding of RTTY signals assumes a knowledge of the baud rate: the increasing popularity of morse-telegraphy and RTTY receivers on the market is prompting many stations to use non-standard baud rates. Commonly encountered rates in the HF bands are 45/50/57/100 bauds per second.

applicator

Mass produced digits, numbers and characters

While searching for a display for the Morse Decoder featured in the May issue, we came across an elegant display system that can be driven directly by a computer and yet uses just one IC.

The display consists of 16 characters each having 16 segments and is fluorescent — a change from the usual LED display. It is controlled by an 'Alphanumeric Display Controller' from Rockwell, the 10937. The fluorescent display and the ADC together form an ideal 16 digit display with the very minimum of components, a fact well illustrated by the circuit diagram in figure 1. In comparison, a similar circuit using discrete components would require 34 transistors and 68 resistors (or 4... 8 buffer ICs).

An even greater disadvantage would be the 34 I/O lines needed between the circuit and the controlling computer — a vast difference from the two (yes, just two) required with the circuit here! One line is required for Clock and the other for Data, what could be more simple? Even with the most basic host computer system (say a 6502, 6532 and 2716), digits and other characters can be displayed with the greatest of ease. Data is transferred from the host computer in serial format. It is initiated by a few control words followed by the ASCII data. Each bit must be clocked in. In order to obtain a 'running' display, all 16 characters must be stepped along by the microprocessor. The layout of the segments of each character is shown in figure 1. As an example, the letter K is displayed when segments h, g, o, j and l are

switched on. The 10937 ADC controls the 16 segments of each of the 16 characters (plus the decimal points and comma tails when needed) by means of Time Division Multiplexing (TDM). Driver stages for all of the segments are included in the IC and the only external components to be added are the pull-down resistors R1 to R34.

Data (8 bit format) at the input of the IC (pin 21) is loaded into an internal display buffer. The segment decoder then translates the contents of the buffer into the segment code for the display. Each data-byte (8 bits) starts with a control bit. If this is logic '0' the remaining seven bits correspond to the ASCII code as shown. If the control bit is logic '1' the remaining bits will be control data.

When in use, the sequence of events

1

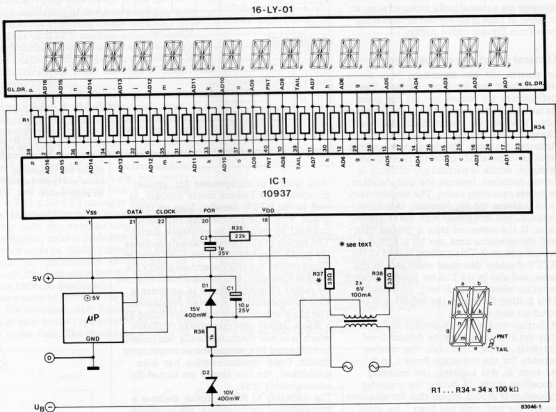

Figure 1. Only one IC is needed to control the display of 16 characters with 16 segments. The ASCII data is entered in serial format from the host computer system. There are only three interconnecting lines, the clock, data and +5 V. It is important that the computer earth is not connected to the circuit.

applicator

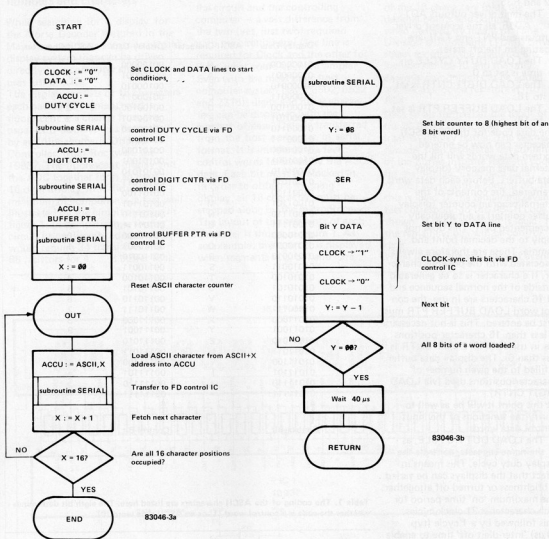

Table 3. With the aid of this flow chart programs can be written to enable ASCII characters to be displayed.

character 1 of the display because $1 - 2 = -1!$ In this case, a further calculation is required: 16 (the total number of characters) minus 1 (the -1 of the previous calculation) equals 15. So, in order to point to character 1 the value 15 (hex F) must be entered.

If it is desired, when programming the ASCII characters, to deviate from the normal 'power on reset' conditions, it will be necessary to enter data in the following manner.

Enter LOAD DUTY CYCLE
Enter LOAD DIGIT CNTR
Enter LOAD BUFFER PTR
Enter the ASCII characters in succession.
Control words can be entered in any sequence. The order of entry is of no concern to the 10937. The coding of the control words will be found in table 2.

A word about timing. Between the end of one data word and the beginning of the next there must be

a delay of at least $40 \mu\text{s}$. The total time period for entering each data must be at least $120 \mu\text{s}$. The timing relationship between signals at the data input and the clock is shown in figure 2.

A point to bear in mind about the hardware. Only the data, clock and +5 V lines are fed from the computer. It is important that the earth connection of the host computer is not connected to the display circuit. The values of resistors R37 and R38

2

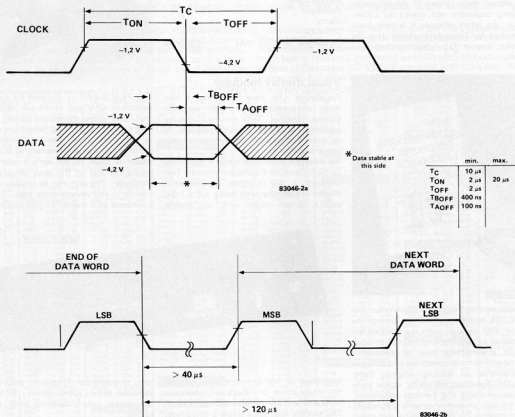

Figure 2. The timing relationship between pins 21 and 22 of the 10937 are illustrated in the waveforms here.

can be found in the following manner. Before the display is wired in, a 100 Ω 1 watt resistor is connected between the two wires leading to the GL DR points of the display.. The voltage across this resistor is measured and should be about 7.2 V_{rms}. This should result in a value of 33 Ω for resistors R37 and R38 when a 2 x 6 V transformer is used. Variations in the transformer secondary voltage can be taken care of by altering the values of R37 and R38.

If desired a manual reset can be incorporated in the circuit by a push button in series with a 100 Ω resistor across capacitor C2.

To finalise, a few points of note about the software. With the aid of the flow chart in table 3, a program can be written that will transfer the ASCII characters of table 1 onto the display. Remember that the first character entered

will be at the right hand end of the display and the last entered will be at the left. Any spaces that occur (if less than 16 digits are used) will be on the left of the display.

IC1	driver-voltage	U _B
10937P-20	20 V	-15 V
10937P-30	30 V	-25 V
10937P-35	35 V	-30 V
10937P-40	40 V	-35 V

Input voltage

(relative to +5 V)

	min.	max.
"1"	+0.3 V	-1.2 V
"0"	-4.2 V	U _B

Current consumption: 40 mA max.

Table 4. Supply voltages and the logic levels for the variations of the 10937 IC. These are measured with respect to the +5 V provided by the host computer.

Literature:
 Rockwell data sheet — 10937 Alpha
 Numeric Display Controller.
 Futaba 16-LY-01 display and
 Rockwell 10937 available from:
 Regisbrook Limited, 215 Kings Road,
 Reading RG1 4LS.
 Telephone 0734 665955.

market

Understand telephones

Telephone communication, a century old, is now — with digitisation — moving into its second major phase of development. Helping engineers and others to understand the latest changes is a new book published by Texas Instruments. It is the twelfth title in TI's 'Understanding . . . series.

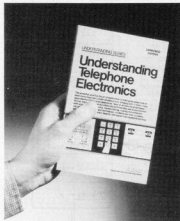

'Understanding Telephone Electronics' follows the series' practice by taking the reader step by step from the simplest explanation of telephonic principles through to an intermediate level of telecomms learning. The book covers the technologies incorporated in dialling, ringing, transmission, signalling, switching, digital techniques, modems and cordless telephones. At the end of each chapter is a summary quiz, making the book ideal for self-paced individual learning. It is available at £3.95 per copy (plus £1.50 per order to cover p+p).

Texas Instruments Limited,
PO Box 50,
Market Harborough,
Leicestershire.

(2699 M)

Antistatic desolder pump

OK Industries' 'desolder' pump has a tip made of a special bronze alloy composition designed for long life. Moreover, static discharges automatically through the hand of an earthed operator making the DP-2 suitable for removing sensitive CMOS components. Suction is precisely regulated to prevent damage to delicate circuitry and the tool, which is self cleaning on each



stroke, offers full industrial performance and reliability.

OK Industries UK Ltd.,
Dutton Lane,
Eastleigh,
Hants,
SO5 4AA
Telephone: 0703 610944

(2697 M)

Visual display modules

Regisbrook Ltd. have announced a new range of products from their exclusive Futaba franchise. They are visual display modules — a single board package of vacuum fluorescent display, driver and power supply.

An example from the range is the VFM 40-S02A vacuum fluorescent module. This provides a 40 character alphanumeric display — each character being a 5 x 7 dot matrix, 5 mm high, with an average

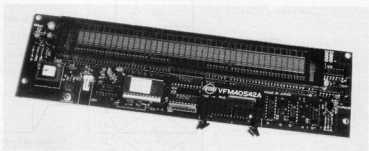

brightness of 180 foot/lamberts. Also on the single board is a Rockwell intelligent controller and a Mitsubishi microprocessor. The module requires a single 5 volt power supply and offers a serial or parallel interface.

Regisbrook Limited,
Studio House,
215 Kings Road,
Reading RG1 4LS,
Berkshire.
Telephone: 0734 665955

(2693 M)

Acoustic resonators

The PKM29-3A0 piezo-acoustic transducer can justifiably claim to be nuisance, delivering over 85 dBA at 3 metres, at a frequency of 3.4 kHz. In fact, we defy anyone reading this with 'normal' hearing to remain in an 'average' room of 200 cubic metres volume with one of these compact transducers sounding an alarm.

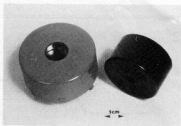

The PKM29-3A0 is designed for external excitation (9 V p-p at 15 mA to deliver that rated output mentioned above).

The smaller of the two resonators shown in the photograph, the PKB8-4A0 is a self-excited sounder, resonant at 2.7 kHz: which is close to the ear's fundamental resonance, and at the peak of perceived 'loudness'. The unit can be powered from 3 to 20 V, and delivers more than 75 dB at a distance of 1 metre. To put this in con-

text, it would be difficult to hold a conversation within approximately 10 feet of the alerter, when powered from a 9 V source.

Ambit International,
200 North Service Road,
Brentwood,
Essex CM14, 4SG.

(2695 M)

next month...

Our Bumper July/August issue

Over 100 circuits including some for Crescendo, Prelude, J.C. and many more.

Not to be missed . . . !

BENCH THERMOMETERS

SERIES 199 £189

6 inputs, Analogue Output, LED

SERIES 299 £149

Single input, Analogue Output LED

Accuracy 0.1% ± 1 digit

FROM
£149



MODELS

199 JC or 299 JC Iron/Constantan - 180 to 760°C × 1°C
199 KC or 299 KC Chromel/Alumel - 50 to 1250°C × 1°C
199 TC or 299 TC Copper/Constantan - 150 to 400°C × 1°C

SERIES 399 PT100 £299 with BCD option £349 Accuracy 0.05% of full scale ± 0.1°C

PT100 £249 with BCD option £299

PT100 3 or 4 wire, 6 inputs, Analogue & BCD Output, Hold Function

399C -99.9°C to 199.9°C × 0.1°C LED

THERMOCOUPLE & PT100 SENSORS

A wide selection of sensor available to suit all applications

THERMOCOUPLE PLUGS & SOCKETS

Plug	J,K,T & CU	£1.35 each
Socket	J,K,T & CU	£1.60 each
Panel Mounting Socket	J,K,T & CU	£1.85 each

THERMOCOUPLE WIRE/CABLE & COMPENSATING CABLE

Please phone for a quotation on your requirements - wide selection available

ACCUREX THERMOMETERS

NEW

9000 SERIES

FROM
£64

Features

- All solid state design
- Liquid crystal display readable under bright ambient conditions
- High stability
- Wide temperature range
- One 9V conventional battery
- 240 volt AC adaptor (optional)
- Battery low indicator
- Long life battery
- Rugged carrying case (optional)

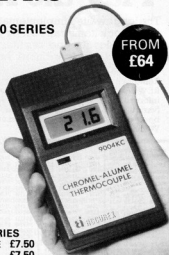

OPTIONAL ACCESSORIES

RUGGED CARRYING CASE £7.50
240V AC ADAPTOR £7.50

9002C (PT100) -200°C to 200°C × 1.0°C to 850°C × 1°C
9003KC (Type K) -50°C to 1200°C × 1°C
9004KC (Type K) -50°C to 200°C × 1.0°C to 1350°C × 1°C
9005KC (Type K) -50°C to 800°C × 1°C

£96
ONLY £64
£99
£76

THERMOCOUPLE SELECTOR UNITS

PORTABLE/BENCH TYPES



Available in Thermocouple Calibrations J,K,T & CU

6 Way - £49
12 Way - £79

DVM - THERMOCOUPLE INTERFACE

RANGE

-50 to 1100°C

ONLY
£35

TYPE K THERMOCOUPLE

400 Hour Battery Life

OUTPUT 1mV/°C
110 × 68 × 33mm



AUTOMATIC COLD JUNCTION COMPENSATION. DESIGNED FOR USE WITH PORTABLE AND BENCH MOUNTED DIGITAL VOLTMETERS TO READ TEMPERATURE OVER A WIDE RANGE.

PANEL THERMOMETERS

96 × 48mm LED

Accuracy 0.2% ± 1 digit

767KC -50 to 1250°C × 1°C

767JC -180 to 780°C × 1°C

767TC -150 to 400°C × 1°C

Model M1018 PT100 £249

Range -99.9°C to 199.9°C × 0.1°C

Accuracy 0.05% of full scale 0.1°C, BCD Output

Recorder Output 10mV/°C



FROM
£89

METERTECH MODEL 3T MULTIMETER

ONLY
£43.50

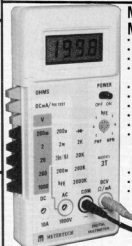

- 12.5mm display
- 10M Ω input impedance
- Automatic zero adjustment
- Automatic polarity switching
- Over range indication
- Fuse circuit protection
- Battery low indication
- HF measurement
- Diode Continuity check
- Accessories included TEST LEADS, BATTERIES & INSTRUCTION MANUAL
- Size 180 × 90 × 35mm
- Weight 300g
- Sampling time 0.25 sec.

OPTIONAL ACCESSORIES
DELUXE PROTECTIVE CASE £6
10AC CURRENT SHUNT £6.50
THERMOCOUPLE INTERFACE
-50°C to 1100°C × 1°C £35.00

DC VOLTAGE (5 ranges) 0.8% accuracy 100uV to 1000V
AC VOLTAGE (2 ranges) 1.2% accuracy 100mV to 1000V
DC CURRENT (5 ranges) 1.2% accuracy 100nA to 10A
RESISTANCE (4 ranges) 1% accuracy 1Ω to 2MΩ

METERTECH MODEL DCMT 301 DIGITAL CAPACITANCE METER

ONLY
£69

- Wide Test Range
- 0.1pF - 2000uF
- 8 Ranges
- LCD Display
- Portable Type
- 0.5% Accuracy
- Accessories Included

INSTRUCTION MANUAL, ALLIGATOR TEST CLIPS, BATTERY + SPARE FUSE

OPTIONAL ACCESSORIES
DELUXE PROTECTIVE CASE £6



data sheet book

Here at last is the book that designers have been waiting for: the Elektor Data Sheet Book. In 240 pages it gives you a CMOS, a Linear, Special Function and Audio Data Book: extensive information on 269 of the most important IC's. A very useful and economical reference book!
£ 8.00 net (+ 50p P&P)

When ordering please use the pre-paid order card in this issue.



RESI & TRANSI BANISH THE MYSTERIES OF ELECTRONICS

Excitement, entertainment, circuits. Complete with printed circuit board and Resimeter. Further adventures and circuits coming soon — starring Resi & Transi, of course!
Price — £ 5.75



TV GAMES COMPUTER

This book, provides a different — and, in many ways, easier — approach to microprocessors. The TV games computer is dedicated to one specific task, as the name suggests. This provides an almost unique opportunity to have fun while learning!
Price — £ 6.75



DIGIBOOK

Provides a simple step-by-step introduction to the basic theory and application of digital electronics and gives clear explanations of the fundamentals of digital circuitry, backed up by experiments designed to reinforce this newly acquired knowledge. Supplied with an experimenter's PCB.
Price — £ 6.00



JUNIOR COMPUTER BOOK 1

For anyone wishing to become familiar with (micro)computers, this book gives the opportunity to build and program a personal computer at a very reasonable cost.
Price — £ 6.50

JUNIOR COMPUTER BOOK 2

Follows in a logical continuation of Book 1, and contains a detailed appraisal of the software. Three major programming tools, the monitor, an assembler and an editor, are discussed together with practical proposals for input and peripherals.
Price — £ 6.50

JUNIOR COMPUTER BOOK 3

The next, transforming the basic, single-board Junior Computer into a complete personal computer system.
Price — £ 6.50

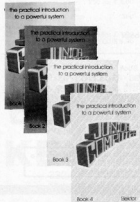

JUNIOR COMPUTER BOOK 4

Book 4, the last in the series, describes all the software required to operate the complete system. A number of peripheral devices, such as a printer and a video terminal, may be 'hooked up' to the computer. During the final stage in its 'growth', the machine is able to extend its linguistic skills, for a special version of BASIC is now available on cassette. As a result, the Junior Computer is well and truly 'launched' as a fully fledged personal computer.
Price £ 6.50

SC/MPUTER (1)

Describes how to build and operate your own microprocessor system — the first book of a series — further books will show how the system may be extended to meet various requirements.
Price — £ 5.50



SC/MPUTER (2)

The second book in series. An updated version of the monitor program (Elbug II) is introduced together with a number of expansion possibilities. By adding the Elektorterminal to the system described in Book 1 the microcomputer becomes even more versatile.
Price — £ 5.50

elektor book service



FORMANT

Complete constructional details of the Elektor Formant Synthesiser — comes with a FREE cassette of sounds that the Formant is capable of producing together with advice on how to achieve them.
Price — £ 6.00

BOOK 75

A selection of some of the most interesting and popular construction projects that were originally published in Elektor issue 1 to 8.
Price — £ 5.00

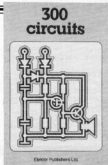

300 CIRCUITS

For the home constructor — 300 projects ranging from the basic to the very sophisticated.
Price — £ 5.50

When ordering please use the Elektor Reader's Order Card in this issue
ADD 50p P&P U.K. AND OVERSEAS

No Compromise



Microdoctor

£295
+VAT

is an alternative to AUTOMATIC TEST EQUIPMENT which can be very expensive. MICRODOCTOR is perfectly adequate for diagnosing faults in microprocessor boards or computers in the REPAIR SHOP or on the PRODUCTION LINE. Reports are PRINTED on the integral thermal printer. Tests supported are CHECKSUM, RAMTEST, WAIT, READ, WRITE, I/O READ, I/O WRITE, DUMP in HEX, DUMP in ASCII, TEST DATA LINES (for shorts between data, address and rails), SEARCH (for two specified bytes), MAP (print a memory map of ROM, RAM, I/O and EMPTY SPACE). Supports both multiplexed and non-multiplexed address data. Standard software will also DISASSEMBLE in Z80 mnemonics — other disassemblers cost extra. Programs for board-testing can be written in MINUTES — and retained for MONTHS even if the power is switched off (CMOS RAM is backed-up with rechargeable battery). Capacity is 15 different programs of 12 tests each. Included are two PROBE CONFIGURATION CARDS (One Z80, other uncommitted), PROBE with 24 inch cable and 40-pin DIL plug — and POWER SUPPLY.

OPTIONAL EXTRAS	
8502 Disassembler Card	£35.00
6800 Disassembler Card	£35.00
8085 Disassembler Card	£35.00
Clip-over PROBE (only needed if up is soldered-in)	£35.00
Thermal Paper (10 Rolls)	£9.00
Spare configuration cards	£6.50

£99
+VAT

The Menta Z80 Development System

uses the MOST POWERFUL LANGUAGE OF ALL — direct ASSEMBLER MNEMONICS. MENTA has VISUAL AIDS to program development which the big systems lack: a TV display of PROGRAM, REGISTERS and STACK, single-step operation (watch the cursor move from instruction to instruction, see the register-contents change, observe stack operations, etc.) BRUGS can be fixed immediately without reassembling. Full speed operation is supported too — with or without BREAKPOINTS. Designed originally for the Schools' Council to teach microprogramming, MENTA is a complex CONTROLLER in its own right, like any other Z80 system, with practical, COMMERCIAL applications in ROBOTICS. Features include CASSETTE INTERFACE, ASSEMBLER/EDITOR, SERIAL DISASSEMBLER, 24 bits of I/O — also TV FLYLEAD, POWER SUPPLY and COMPREHENSIVE MANUAL with SOURCE CODE LISTING.

MODULES AVAILABLE	
Universal Input/Output Device	£21.00
Analogue to Digital Converter	£18.00
Digital to Analogue Converter	£14.00
D.C. Motor and Current Buffer	£12.00
Switching Input Module Analogue/Digital	£10.00
Pupil Reader	£3.00
Teacher's Guide	£2.50

£1950
+VAT

Thandar 7A 2080 20mhz Logic Analyser

Dataman Designs Retrofit for 7A2080

Gives R.S. 232 output facility for printed STATE and TIMING diagrams. Also DISASSEMBLES in Z80, 6502 or 6800 mnemonics on-screen or to printer.

£295.00

Olivetti Typewriter Interfaces

for ET121 and ET221 machines which permit the typewriter to be used as a DAISY WHEEL PRINTER for computers implementing the RS232, IEEE 488 (PET) or CENTRONICS PARALLEL buses, almost all computers in fact. Great for word processing and letter-writing! Same price, fitting free if requested (you pay carriage on typewriter if we fit).

£195.00

Ultra-Violet Eprom Erasers from

£33.00

£169
+VAT

Softy Eprom Programmer/Emulator

SOFTY has functions equal, at least, to equipment which sells for over £500. SOFTY EMULATES AND PROGRAMS 2716, 2732, 2532 EPROMS. (The type is selected by a personality switch. SOFTY will copy any of these EPROMS to any other). SOFTY has a HEX KEYPAD, a fast CASSETTE INTERFACE, a MEMORY MAP TV DISPLAY with powerful editing — such as INSERT, DELETE, SHIFT-BLOCK and many other facilities — too many to list here. RS232 SERIAL and CENTRONICS PARALLEL routines for INPUT and OUTPUT are standard. The price includes TV FLYLEAD, POWER SUPPLY and ROM EMULATOR CABLE WITH 24 PIN DIL PLUG. SOFTY is used as a DEVELOPMENT SYSTEM for new products or just as a STAND-ALONE EPROM PROGRAMMER.

Adequate performance
at sensible prices

LOMBARD HOUSE,
CORNWALL ROAD,
DORCHESTER, DORSET DT1 1RX.
Telephone: Dorchester (0305) 68066
Telex 418442 DATAMAN

Dataman
Designs

Prepaid orders normally shipped by return.
Prices include first-class recorded post in UK.
Securion, Red Star, etc. at extra cost.
VAT should be added at current rates.

Carriage Free on Orders in excess of £50.00
Add £2.50 if less

Send now for an application form — then buy it with MAPCARD.

MAPCARD gives you real spending power — up to 24 times your monthly payments — instantly!

Maplin News

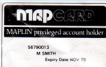

Sole UK Agents for Heathkit

NOW THE world-famous Heathkit range of superb electronic kits is available from Maplin — the newly appointed exclusive UK distributor. Kits range from a simple clock for beginners to a unique Robot (see pic) with which you can learn about robotics.

There is a range of training courses covering electronics and computing topics, many containing constructional projects. For full details, pick up a copy of the latest Maplin magazine or write for a free copy of our Heathkit catalogue. Order As XH625.



GREAT PROJECTS FROM E&MM



OUR NEW book "Best of E&MM Projects Vol. 1" brings together 21 fascinating and novel projects from E&MM's first year.

Projects include Harmony Generator, Guitar Tuner, Hexadrum, Synptom, Auto Swell, Partylite, Car Aerial Booster, MOS-FET Amp and other musical, hi-fi and car projects. ORDER AS XH61R. PRICE £1.

Computer Shopping Arrives

AS FROM June 1st you can place orders directly with our computer for your personal computer. The computer shopping revolution has arrived! To communicate, you'll need a modem (our RS232 compatible modem kit is LW99H price £39.95) and an interface (our ZX81 interface LK08J) price £24.95 is available already with many more for most popular micros coming soon).

Just dial us on 0702 552941 and you'll be able to interrogate our stock file then place your order, type in your credit card number and a few minutes after you hang up your order will print out in our warehouse ready for packing. And all without saying a word.

Try out the future way of shopping now! You'll see immediately what stock we've got available and you'll discover how easy it is to ensure your order is exactly right. And you'll see precisely what the current price is for each item and what total amount will be charged to your credit card. It all helps to make buying easier. So give us a ring now!

Maplin's Fantastic Projects

FULL DETAILS in our project books. Price 79p each.

In Book 1 (XA01B) 120W rms MOSFET Combo-Amplifier • Universal Timer with 18 program times and 4 outputs • Temperature Gauge • Six Vero Projects.

In Book 2 (XA02C) Home Security System • Train Controller for 14 trains on one circuit • Stopwatch with multiple modes • Miles-per-Gallon Meter.

In Book 3 (XA03D) ZX81 Keyboard with electronics • Stereo 25W MOSFET Amplifier • Doppler Radar Intruder Detector • Remote Control for Train Controller.

In Book 4 (XA04E) Telephone Exchange for 16 extensions • Frequency Counter 10Hz to



600MHz • Ultrasonic Intruder Detector • I/O Port for ZX81 • Car Burglar Alarm • Remote Control for 25W Stereo Amp.

In Book 5 (XA05F) Modem to European standard • 100W 240V AC Inverter • Sounds Generator for ZX81 • Central Heating Controller • Panic Button for Home Security System • Model Train Projects • Timer for External Sounder.

In Book 6 (XA06G) Speech Synthesiser for ZX81 & VIC 20 •

Module to Bridge two of our MOSFET Amps to make a 350W Amp • ZX81 Sound on your TV • Scratch Filter • Damp Meter • Four Simple Projects.

In Book 7 (XA07H) • Modem Interface for ZX81/VIC20 • Digital Enlarger Timer/Controller • DXers Audio Processor • Sweep Oscillator • Minilab Power Supply • Electronic Lock • and others.

*Projects for Book 7 were in an advanced state at the time of writing, but contents may change prior to publication (due 14th May 1983).

MATINEE ORGAN

EASY-TO-BUILD, superb specification. Comparable with organs selling for up to £1000.

Full construction details in our book (XH55K). Price £2.50. Complete kits available. Electronics (XY91Y) £299.95*. Cabinet (XY93B) £99.50*. Demo cassette (XX43W) £1.99. *Carriage extra



25W Stereo MOSFET Amplifier



- Over 26W/channel into 8Ω at 1kHz both channels driven.
- Frequency response 20Hz to 40kHz ± 1dB.
- Low distortion, low noise and high reliability power MOSFET output stage.
- Extremely easy to build. Almost everything fits on main pcb, cutting interwiring to just 7

wires (plus toroidal transformer and mains lead terminations). • Complete kit contains everything you need including pre-drilled and printed chassis and wooden cabinet.

Full details in Projects Book 3. Price 79p (XA03D). Complete kit only £55.20 incl. VAT and carriage (LW71N).

Maplin's New 1983 Catalogue

Over 390 pages packed with data and pictures and all completely revised and including over 1000 new items. On sale in all branches of WH SMITH. Price £1.25.



MAPLIN ELECTRONIC SUPPLIES LIMITED, P.O. Box 3, Rayleigh, Essex SS6 8LR. Telephone: Sales (0702) 552911 General (0702) 554155.

Shops at: 159 King St., Hammersmith, London W6. Tel: 01-748 0926. 284 London Rd., Westcliff-on-Sea, Essex. Tel: (0702) 554000. Lynton Square, Perry Barr, Birmingham. Tel: (021) 356 7292.

Shops closed Mondays. All prices include VAT & carriage. Please add 50p handling charge to orders under £5 total value.

POST THIS COUPON NOW!

Please send me a copy of your 1983 catalogue. I enclose £1.50 (incl. P&P). If I am not completely satisfied I may return the catalogue to you and have my money refunded. If you live outside the UK send £1.90 or 10 International Reply Coupons.

Name

Address

Post Code

E683