

elektor

up-to-date electronics for lab and leisure

D 71683

93

January 1983

75 p.

FR 112 p. (incl. VAT)

\$2.50

AIR-MAIL COPY

Sunder Singh

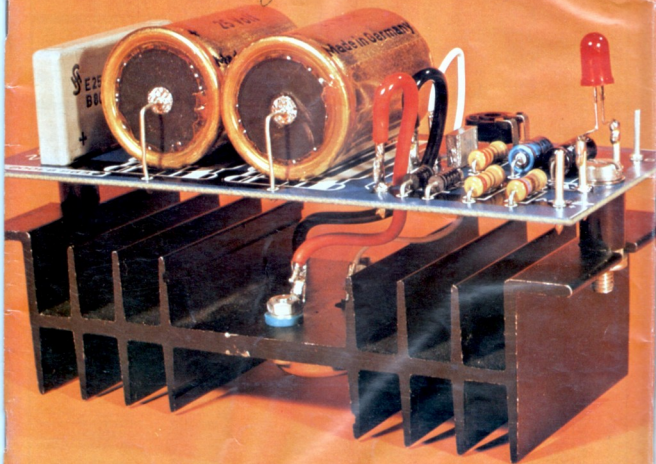

countdown and d.c. protection for the **CRESCENDO** ◊
3A computer supply ◊ mate the darkroom computer
to the **PCS 2000** ◊ **improve your connections with a**
milli-ohmmeter ◊ **digital audio - a giant step, or a**
small leap?

contents

Smile Sign

selektor	12-17
coming soon?	12-19
There is something fascinating about predictions. Journalism in general and magazine editors in particular love to look into a crystal ball at the beginning of every year. This article is one of those ...	
milliohmmeter	12-24
A more precise method to measure the resistances of loudspeakers, coils, conductors (printed circuit board copper tracks) and the like. The lowest measuring range is $0.5 \Omega \pm 1\%$ (full scale deflection), which really gives us something to work with.	
the accessories for the Crescendo power amplifier	12-28
The second part of the XL system, containing the protection circuits for the Crescendo power amplifiers. The d.c. detection and power-up circuits in this article are a must for any good quality power amplifier.	
darkroom computer tips	12-33
with contributions from H. Fietta. As a result of the many enquiries received from readers, we describe the manner in which our darkroom computer can be connected to the well known Philips enlargers; PCS 2000 and PCS 130/150. A new method of obtaining better linearity of the thermometer is also shown.	
chips for digital audio	12-36
So far digital audio has restricted itself to the studios. But, let's face it: there is no doubt that it will soon be in the living room. Before going out and throwing away your existing system it is better to find out a little about this new development.	
3 A computer supply	12-43
This 5 V/3 A power supply is ideal for powering additional memories, peripheral equipment and the like. Internal protective circuits against excessive load currents and temperature rise ensure that the power supply can survive considerable mistreatment.	
traffic-light control system	12-46
D. Herzberg. Apply the Junior for a classical task; a control function which can otherwise only be implemented with considerable amounts of hardware.	
technical answers	12-48
The home telephone help article last month started our new section. This month we continue with further useful hints, ideas and tips.	
ejektor	12-50
from an idea of E. Muller. An invitation to investigate, improve and implement imperfect but interesting ideas: the 'Fourier' synthesis.	
tomorrow's music	12-53
Factors affecting the change in 'hi-fi' techniques are: the market, current and future legislation and last, but, not least, the electronic components industry. The article takes a look at 'hi-fi' up to the end of the century.	
upper and lower case on the Elekterminal	12-56
D. Paulsen. The ELEKTERMINAL becomes an elekterminal. Continuing with the series of extensions, lower case and special characters are introduced.	
market	12-60
switchboard	12-61
EPS service	12-72
advertisers index	12-74

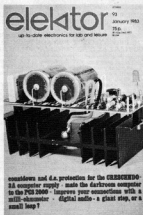

resistors and d.c. protection for the CRESCENDO-3A computer supply - make the darkroom computer to the PCS 2000 - improve your connections with a milliohmmeter - digital audio - a giant step, or a small leap?

Here we are; 1983! A continuation of projects started during last year, new ones to wet the appetite for the coming months and certain subtle changes to the look of our inside pages. These changes which could be termed as our winter clean look very nice to us, but it would be very much appreciated if readers could supply their views. Next time you send us a technical question, why not include your comments?

MARKETED BY

precious[®]

ELECTRONICS CORPORATION

HEAD OFFICE: BRANCH,
S. CHENNAM LANE, S. ATHAPPATTAN ST., MOUNT ROAD,
DR. SHANMUGAN NARAYAN, MADRAS 600007.
BOMBAY 400001. PHONE 842718.
PHONE'S 388479/387433

Thandar's unbeatable price/performance combination means every engineer, serviceman and technician can enjoy the benefits of full performance portable test instruments.

Quality and reliability has been brought to a wide range of low cost instrumentation. From multi-

meters through to logic analysers Thandar have applied the knowledge gained through a history of innovative electronics to give you robust instruments with professional specifications versatile enough for bench or field use at prices that are hard to beat. Most of the products in the range

can be combined with accessories which expand applications beyond the realms of low cost testing. Mains or battery operation and low weight make them truly the most portable instruments available today. All Thandar instruments carry a one-year warranty.

PUTTING THE BEST WITHIN YOUR GRASP

- MULTIMETERS
- FREQUENCY METERS
- PRE-SCALERS
- FUNCTION GENERATORS
- PULSE GENERATORS

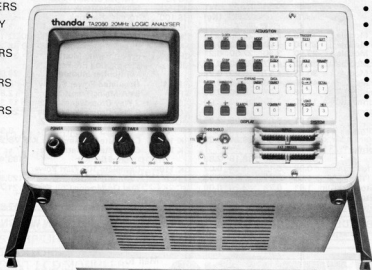

- THERMOMETERS
- OSCILLOSCOPES
- LOGIC ANALYSERS
- DATA PODS
- VIDEO PRINTER
- VIDEO MONITORS
- ACCESSORIES

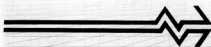

thandar
ELECTRONICS LIMITED

London Road, St. Ives, Huntingdon,
Cambridgeshire PE17 4HJ England.
Tel: (0480) 64646. Telex: 32250.

TH04

**3 x £1
DISCOUNT
VOUCHERS**

**ambit's new
autumn/winter
catalogue
is
OUT
NOW!**



**128
PAGES**

70p

**ALL THE 'USUAL' BITS
(Rs, Cs, Tr's, ICs etc)
+ ALL THE
TRICKY BITS**

**at all good
newsagents
or direct**

- * TOKO COILS, INDUCTORS, LC FILTERS
- * PCM FILTERS, VHF/UHF HELICAL FILTERS
- * UNELCO CAPACITORS
- * PCI INTELLIGENT LCD MODULES
- * TOKO SWITCHES : F SERIES/R7000 SERIES
- * ALPS POTENTIOMETERS AND KEYSWITCHES
- * TOYO-TSUSHO COAX RELAYS FOR TX/RX
- * CRYSTAL FILTERS, CERAMIC FILTERS
- * WELER SOLDERING IRONS
- * COOPER TOOLS
- * TEST EQUIPMENT
- * BOOKS, MANUFACTURERS' HANDBOOKS
- * HARDWARE, CASES, PANELWARE, ETC.
- * MODULES, R&E W KITS
- * RF POWER DEVICES

**ORDERS SUBMITTED USING STOCKCODES
DESPATCHED WITHIN 8 WORKING HOURS**

*** PHONE ORDER SERVICE — (NO MACHINES!)**

PLEASE NOTE OUR NEW PHONE SYSTEM AUTOMATICALLY STACKS CALLS
IN ORDER OF ARRIVAL SO PLEASE WAIT IF NOT ANSWERED IMMEDIATELY

**8 AM — 7 PM MON — SAT
0277 230909**

*** COMPUTER ORDER SERVICE — 'REWTEL'**

**6 PM — 9 AM 300 BAUD/RS232
(IT MAY BE 24 HRS BY THE TIME YOU READ THIS)
0277 230959**

ambit INTERNATIONAL

206, NORTH SERVICE ROAD
BRENTWOOD, ESSEX
CM14 4SG
Telephone: (0277) 230909
Telex: 995134 AMBIT G



**7 HUGHENDEN
ROAD, HASTINGS,
SUSSEX, TN34 3TG
Telephone:
HASTINGS (0424)
436004**

ELECTRONIC KITS

Post & Packing 50p for KS kits, 75p for UK kits, £1.00 for Cabinets. Send 20p S.A.E. for catalogue of our extensive range of Kits & Cabinets. Trade, Educational & Export enquiries welcome.

<p>KS 100</p> <p>MINI VHF SUPER REGENERATIVE RECEIVER 88-108 MHz 9V D.C. £ 5.27 inc V.A.T.</p>	<p>KS 200</p> <p>Mini FM Transmitter 88-108 MHz 9 V d.c. (Not licensable in UK) £ 7.37 inc V.A.T.</p>	<p>UK 108</p> <p>MINIATURE F.M. TRANSMITTER NOT LICENSABLE IN U.K. £ 9.46 inc V.A.T.</p>
<p>KS 238</p> <p>3 CHANNEL MICRO PHONE OPERATED SOUND TO LIGHT 300W PER CHANNEL, 240V A.C. £ 11.98 inc V.A.T.</p>	<p>KS 240</p> <p>3 CHANNEL SOUND TO LIGHT, OUTPUT 3 x 1 KW 240V £ 13.70 inc V.A.T.</p>	<p>KS 260</p> <p>3 CHANNEL CHOSE LIGHT, 1 KW PER CHANNEL, 240V A.C. £ 10.52 inc V.A.T.</p>
<p>KS 262</p> <p>10 CHANNEL CHOSE LIGHT, 300W PER CHANNEL, 240V A.C. £ 14.73 inc V.A.T.</p>	<p>UK 716</p> <p>THREE-WAY STEREO MIXER, PHONO, AUX, MICROPHONE £ 24.21 inc V.A.T.</p>	<p>UK 232</p> <p>ANTENNA AMPLI- FIER FOR AM/FM, A.M. GAIN 25dB FM 15 dB £ 5.27 inc V.A.T.</p>
<p>KS 272</p> <p>6 CHAN HIGH POWER VU DISPLAY, 300W PER CHAN, 240V A.C. £ 15.79 inc V.A.T.</p>	<p>UK 718</p> <p>STEREO STUDIO MIXER, INPUTS: 2 PHONO, 1 TAPE, 1 AUX, 2 MICRO PHONE £ 69.45 inc V.A.T.</p>	<p>KS 300</p> <p>WESTMINSTER CHIMES (BIG BEN) 6-10V D.C. £ 9.48 inc V.A.T.</p>
<p>UK 677/A</p> <p>REGULATED SUPPLY 0-20V, 2.5A £ 54.23 inc V.A.T.</p>	<p>UK 558</p> <p>600 MHz PRESCALER + 5 V D.C. £ 28.42 inc V.A.T.</p>	<p>UK 562</p> <p>TRANSISTOR AND DIODE TESTER £ 14.73 inc V.A.T.</p>
<p>UK 666</p> <p>0-30V, 2.5A REGULATED SUPPLY WITH DIGITAL DISPLAY £ 76.82 inc V.A.T.</p>	<p>UK 733/A</p> <p>PSYCHEDELIC LIGHTS CONTROL 1 KW PER CHANNEL BASS/MIDDLE/ TREBLE CONTROLS £ 23.15 inc V.A.T.</p>	<p>UK 875</p> <p>Capacitive Discharge Electronic Ignition £ 21.54 inc V.A.T.</p>
<p>UK 882</p> <p>CENTRALIZED ANTI-THEFT ALARM £ 33.67 inc V.A.T.</p>	<p>UK 406</p> <p>PORTABLE SIGNAL TEACHER, COMPLETE WITH R.F. PROBE £ 24.21 inc V.A.T.</p>	<p>KS 230</p> <p>15+15W R.M.S. STEREO AMPLIFIER 240V D.C. £ 16.84 inc V.A.T.</p>
<p>UK 271</p> <p>INTEGRATED CIRCUIT AMPLIFIER WITH TONE & VOLUME CONTROLS £ 8.42 inc V.A.T.</p>	<p>UK 823/W</p> <p>CAR BURGLAR ALARM, READY ASSEMBLED £ 11.98 inc V.A.T.</p>	<p>KS 470</p> <p>SOUND OPERATED SWITCH, 9-12V D.C. COMPLETE WITH MICROPHONE £ 8.42 inc V.A.T.</p>
<p>KS 420</p> <p>DIGITAL D.C. VOLT. METER 300mV, 999V, 0.5V D.C. £ 17.89 inc V.A.T.</p>	<p>KS 490</p> <p>NICAD BATTERY CHARGER 10-20-45-100-150 mA, 15V D.C. MAX. 240V A.C. £ 8.42 inc V.A.T.</p>	<p>KS 143</p> <p>L.E.D. VU DISPLAY, INPUT 1-100W 5-12V D.C. £ 9.48 inc V.A.T.</p>

Cutting costs with sparks

by R.A.J. Arthur

A new technique for machining hard metals is 50 times faster than the closest comparable process. It promises great benefits to the aircraft and motor industries and, because it can be used under water, will be a valuable aid for offshore work. Using sparks in liquids to drill holes in hard metals under the sea, though it sounds arcane enough to conjure up the ghost of Jules Verne, is a literal description of Aberdeen University's latest contribution to underwater technology. A reevaluation of existing methods has led a research team at the University to a novel way of removing metal 50 times faster.

One technique of spark erosion developed in recent years for drilling or cutting to shape some of the very tough, heat-resistant alloys needed in the aircraft, motor-vehicle and offshore oil industries is Electro-discharge machining (EDM). It offers an alternative to expensive high-energy beam processes such as laser and electron beam drilling. But EDM, though it can drill accurate holes, has the disadvantage of causing damage to surfaces. It cannot be used under water, and is slow in comparison with another recent technique, electrochemical machining (ECM), which removes metal by electrolysis.

ECM leaves a better surface than EDM, but the effect can be spoiled by accidental sparking, which often occurs in long holes of small diameter. The technique now developed combines the principles of EDM and ECM, is completely suitable for undersea application and brings a remarkable gain in speed and flexibility. Called Electrochemical Arc Machining (ECAM), it was evolved by the team at Aberdeen, led by Dr J. McGeough of the Department of Engineering.

Electrolysis and Sparks

Up to 50 times as fast as EDM, the new process depends, as does ECM, on the passage of direct current through an electrolyte, an ion-containing solution in which positively-charged ions move towards the cathode and negatively-charged ions towards the anode of an electric circuit, thereby releasing reaction products. In ECAM, this electrolysis is supplemented by spark erosion: a shower of tiny sparks (or, more precisely, arcs) cuts or drills metals to any desired shape.

There are lightweight tools for divers to use the process, complete with a power pack. Because the electrode never actually makes contact with the work surface and does not need to rotate like a drill, it can be of any shape, depending on the type of cut, and a soft metal can be used to machine a hard one. Other possible

ECAM applications include rapid removal of surplus material on car bodies, metal turning and wire cutting.

In the ordinary EDM process the workpiece acts as one electrode and the tool as the other. To remove metal, a shower of erosive sparks is discharged across a dielectric. Although most erosion occurs on the workpiece, there is also tool erosion, which, by well-chosen process conditions and tool materials, can be reduced to about one per cent of workpiece erosion.

In ECM the metal is removed from the anodic workpiece by electrolysis. The process is known as electro-polishing, which is electroplating in reverse, and here, too, the cathode is the shaping tool. A small gap between the two electrodes is filled by an electrolyte. Electrolytic dissolution from the anode removes metal at a higher rate than is possible with EDM.

Whereas sparking does the work in EDM, in ECM it is a defect to be eliminated, with measures to prevent short-circuiting. From this came the germ of an idea that the powerfully eroding sparks could be made to play a positive part in a process based on electrolysis.

Thermal action

The principle of ECAM is to augment the electrochemical action by thermal metal removal. The lifetime of the sparks is extended. In this technique a spark is regarded as a transient, noisy discharge between two electrodes and an arc as a stable thermionic phenomenon. Discharges with durations from about 1 μ s to about 1 ms are sparks, and those of 0.1 s are arcs. Discharges in ECAM, with their duration, energy and time of ignition completely under control, are not really sparks but short-duration arcs. Such arcs remove metal by intense heat; more metal is removed simultaneously by electroplating in reverse as a flow of electrolyte under pressure is maintained in the gap (typically 1 mm) between tool and anodic workpiece, which could be a large object such as a ship's hull or an underwater structure.

In some versions, the electrolyte is pumped out from the hollowed centre of a copper cathode tool, to flow between tool and workpiece where it also serves to flush out debris, gas and heat. The similarity between saline electrolytes and sea water makes the sea as natural an element for ECAM work as paraffin or light oil is for EDM.

One factor to do with the high rate

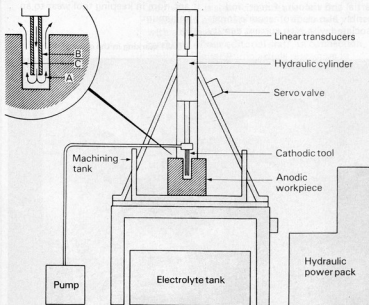

Schematic diagram of an ECAM drilling machine. Sparking in the electrolyte takes place at the leading edge (A). Along the side walls (B, C) electromechanical machining ensures a bright, smooth finish.

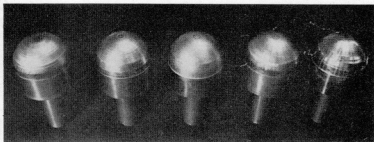
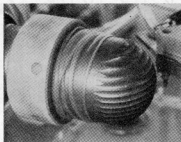

Left: A component milled under computer control. Its surface has been left with cusp-like irregularities, common in the manufacture of dies and moulds; the traditional way of producing a smooth surface is to finish it by hand. Right: Components similar to that on the left, after various stages of ECAM and ECM. ECAM rapidly removes the cusps and about half a minute of ECM leaves the surface bright and smooth.

of metal removal is the use of electrode vibration. In the basic experimental apparatus, the vibration is applied to the anodic workpiece by a hydraulic ram, which also feeds in the workpiece to the tool.

The apparatus comprises a system for controlling the movement of the electrode, an electrolyte flow system, a power supply and instrumentation to enable process conditions to be monitored. The ram which advances the anode to provide tool-feed, vibrating it at the same time, operates from a hydraulic cylinder. Motion of the ram is controlled by a differential amplifier that receives a ramp voltage from a function generator.

Ram feed-rate is preset by adjusting the frequency of the signal generator. Ram oscillation frequency is controlled by the output frequency of the generator and can be locked to that of the pulsed d.c. power supply. The amplitude of ram oscillation can be controlled by the amplitude of the output signal of the signal generator and also from the differential amplifier. Ram position can be adjusted from the differential amplifier.

Electrolyte

In some applications, the electrolyte is a 25 per cent (weight/volume) aqueous solution of sodium nitrate at a temperature of between 18 °C and 21 °C. It is drawn from a storage tank by a diaphragm pump, and a control valve in the flow line to the drill-electrode allows pressure to be present in the range from 13 bar to 120 bar. During drilling, electrolyte pressure is kept constant at 30 bar. With a one-millimetre gap between electrodes, the rate of flow is typically 6 l/min reducing to about 2.5 l/min with the deepening of the hole.

The cathodic drill electrode, a hollow copper tube 50 mm long and with an inside diameter of 1.325 mm and outside diameter 3.175 mm is soldered to a threaded bolt and screwed into a brass electrolyte manifold. Anodic workpieces used in experiments consisted of mild steel blocks mounted on a Perspex block.

The means for the formidable rate of metal removal in ECAM was provided by exploiting certain characteristics of sparks in an electrolyte. Increasing the electric field across the electrodes or decreasing the gap causes the neutral particles to become ionized by electrons emitted from the cathode and accelerated towards the anode; the positively-charged ions (cations) are accelerated towards the cathode. As more and more ionization takes place, a chain reaction builds up and creates an avalanche of ions in a region of complex interactions, that is, the plasma channel. Full development of a spark is very rapid and, once initiated, the spark can be maintained by a much lower voltage. Temperatures of many thousands of degrees Celcius in the plasma channel mean that any electrolyte or metal debris in the path of the discharge will be quickly evaporated, leading to the explosive expansion of a high-pressure bubble. Forces that oppose expansion include local pressure of the electrolyte, inertial and viscosity forces, and possibly also electromagnetic forces associated with high current density.

Power density

Power densities of the order of 10^6 to 10^{10} A mm⁻² may occur in the discharge channel, giving power densities that cause the electrode temperature to rise at a rate of 10^9 to 10^{10} °C s⁻¹, and even sparks of a few microseconds duration lead to melting of the electrodes.

It is only when the voltage drops and the spark declines that the sudden removal of pressure allows an explosive removal of evaporated metal, and some in a molten condition, from the superheated electrodes. Though other complex mechanisms are at work, this is how most of the thermal removal of metal takes place.

Once conclusion is that for the best results the spark should be stopped before expansion of the discharge channel causes loss of power density, cooling, and a slower rate of metal removal. The electron avalanche strikes the anode before the positive-ion avalanche, with its much higher energies, reaches the cathode, so early ending of the spark is important, too, in keeping tool wear to an minimum.

ECAM sparking in the electrolyte.

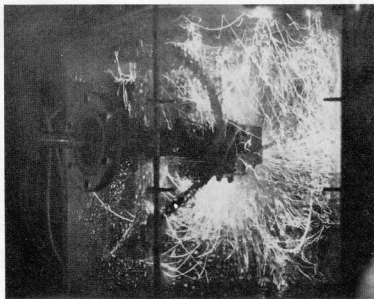

There is something fascinating about predictions. Soothsayers, tea-leaves and crystal balls have gone out of fashion: they don't seem to have a sufficiently solid scientific basis. In their stead, we now have the long-range weather forecast. That has facts, equipment and scientific study to back it up — and 'statistics' to blame its errors on. An unbeatable combination!

Something else is required to satisfy the craving for really long-term prophesy. The best solution so far seems to be science fiction. Best-selling authors often have a scientific background, and they do their utmost to get their facts right — or at least ensure that the 'facts' in the story are not at odds with current scientific certainty. Furthermore, they have two good escape routes from the danger of making incorrect predictions: they can situate the story so far in the future that they won't be around when the complaints arise, and they can claim that it was all just done 'in the interest of making a good story'.

Then there is a third category: journalism in general, and magazine editors in particular. Come January — certainly at the beginning of a decade — and the floodgates are opened. This article is one of those . . .

coming soon?

this year —
next year —
sometime —
never?

In this third category, the 'solid scientific foundation' is more tenuous than that of the weather forecast, but more solid than that of science fiction — at least, it ought to be. As in all three types of prediction, errors are possible — likely, even. Fortunately, there is an almost perfect escape: selective memory. Ten years from now, we may remind you of our correct predictions; but we will all have forgotten how wildly wrong we were on other points. Meanwhile, we can enjoy our phantasy game!

Actually, it is sheer coincidence that this article is in a January issue. It all started with a difference of opinion between two members of our editorial staff, in connection with the Digital Audio article elsewhere in this issue. When can we expect solid-state memories to replace records and tapes? 1990 or 2000? How fast are memories growing? The only way to find out is to check through our historical records, and attempt to evaluate the general trend. Along the way, we turned up quite a lot of dates that fascinated us. From that point, it was one small step: if we're intrigued, it's quite likely that our readers will be! Hence this survey: developments in electronics from 1870 to 2000.

Past history

Who made the first semiconductor diode? Mr. Braun, in 1874! It was known as the 'cat's whisker'. Who invented the tetrode? You'll never guess: Mr. Schottky! What were the first electronic computers like? Take ENIAC, in 1946: 18,000 valves, weighing 30 tons, power consumption 150 kW, clock frequency 100 kHz, filling a 30' x 50' room. It took nearly three seconds to multiply two ten-digit numbers.

Compare that with today's pocket calculators!

A few highlights over the past century-and-a-bit are given in table 1. It is by no means complete: it merely reflects a few dates that struck us in the course of our browsing. One striking fact is that some ideas are much older than we thought (for instance, Baird demonstrated colour TV in 1928). Furthermore, the technological revolution is remarkably rapid, and it is speeding up! This may not be immediately apparent — we have become used to rapid development — but just think how long it took to progress from the wheel to the steam engine! Then compare that with the progress from Edison's tin-foil-cylinder phonograph (1877) to Sony's flat-screen pocket TV in 1982 . . .

Even within the last century, accelerated development is apparent. It took about a decade from the triode (Lee de Forest, 1906) to the tetrode (Schottky, 1919), the pentode (1929, Holst and Tellegen), and the beam tetrode (1936). It took less than five years from the germanium diode (mid '40s) to the transistor (1948, Bardeen, Brittain and Schockley), the IC opamp (early '50s), and the thyristor, FET, tunnel diode and mesa transistor (1957/1958).

Initially, it took one year to halve the price of basic four-function pocket calculators: \$ 395 in 1970, \$ 199 in 1971, \$ 99 in 1972, through to \$ 5.99 in 1976. To put it another way: it took about thirty years to shrink a 30 ton monster (ENIAC) into a far superior pocket-sized machine (Hewlett-Packard's HP-65: the first programmable pocket calculator, introduced in 1974, for \$ 795). And it took less than twenty years to progress from the first mass-produced mini-computer costing less than \$ 20,000

Table 1. A few highlights over the last century-and-a-bit.

year	components	audio	radio/TV	computers
1870-1880	cat's whisker diode	telephone (Bell), phonograph (Edison)		
1880-1890		stereo PA	Nipkow 'Telescope'	
1890-1900		disk record	transmission (Marconi)	
1900-1910	triode		crystal receiver	
1910-1915				
1915-1920	tetrode	capacitor mike	superhet, SSB	flip-flop circuit
1920-1925		tone control		
1925-1930	pentode	negative feedback, crystal pickup	TV broadcast, colour, stereo TV, large screen	
1930-1935		hi-fi, vinyl disc, 33 $\frac{1}{3}$ RPM, juke box, moving coil mike	FM, UHF, PLL circuit	
1935-1940	beam tetrode J-FET theory			Boolean logic applied, Bell Model I relay comp. Model III relay comp. ENIAC
1940-1945		tape recorder		
1945-1950	Germanium diode, transistor, p.c.b. IC opamp	33 $\frac{1}{3}$ and 45 RPM commercial discs		
1950-1955	thyristor, FET, tunnel diode, mesa	stereo disc, 4-track tape	colour video tape deck	IBM 701, magnetic core FORTRAN
1955-1960				
1960-1963	planar, epitaxial, RTL, TTL, MOSFET, LED, MOS IC, Gunn diode			
1963-1966	DIP package, μ A 709			PDP-8
1966-1970	1 K ROM	cassette-recorder		PDP-11, hand-held calculator 8-bit CPU Josephson switch, programmable calculator
1970-1973	2 K EPROM			
1974	4 K dyn. RAM			
1975				
1976			video disc	16-bit CPU TRS-80
1977	16 K dyn. RAM			
1978				
1979	64 K dyn. RAM 64 K EPROM			
1980	64 K stat. RAM			
1981	256 K dyn. RAM		flat screen pocket TV	
1982				

Figure 1. The number of active elements on a chip is increasing by an order of magnitude every five years, and there is no sign that this is slowing down. Within a year or two, that should lead to the 1 Mbit dynamic RAM — or a 16-bit processor with 16 Kword on-chip RAM!

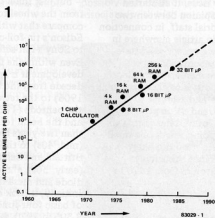

(the PDP-8, introduced by Digital Equipment Corp. in 1965) to today's TV games computers, hand-held chess sets and low-cost personal computers (like the ZX 81). Let's plot a few trends. Figure 1 shows the increase in the number of active elements per chip, from Fairchild's RTL flip-flop in

1961 to Hewlett-Packard's recent 750,000 transistor monstrosity. If this trend continues for a few years, we should hit 10^7 active devices by 1990. Given one device per memory cell, with a few spare for testing and internal organisation, this would mean 9 or 10 Mbit RAMs. WOW! In the year 2000, assuming the same trend, we'd be hitting 3 Gbit or so. Enough for 30 minutes of digital audio recording on one single chip! And that's not allowing for increasingly fast progress in technological development; a fair assumption on the short term, it would seem.

Talking about digital audio: what about playback-only? In current technical terms: what about ROMs? In some ways, ROM technology seems to be lagging. Given the same rate of progress as RAMs, EPROMs and such, we should have 1 Mbit ROMs by now (the 1 K ROM was introduced in 1968). In essence, a ROM cell needn't be larger than the area of two crossing minimum-width conductors on the chip; currently, that means approximately $1 \mu\text{m}$. Even allowing for insulation and sophistication, 1 Mbit shouldn't be a problem. And the 'big shrink'

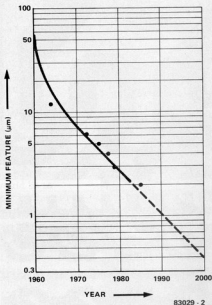

Figure 2. The big shrink. Despite the challenges associated with reducing the feature sizes in an integrated circuit, dimensions will continue to shrink. If minimum features follow the curve above, the 1 µm barrier for commercial devices will be broken within a decade.

is continuing: the prognosis given in figure 2 was released by IBM in 1980. This trend could mean that playback-only digital audio would be commercially viable in the 1990s.

Not to mention bubble memories.

Admittedly, Intel seem to be the only people who are still active in this field. But they have already got a 4 Mbit bubble device! Promising . . .

Another point of interest is the development time from first prototype to commercially viable product. Colour TV was proposed in 1928; NTSC dates from the late 40s. 33 1/3 RPM records were tried in 1931; the real start was in 1948. There is a distinct lag . . . The first Josephson switch was demonstrated in 1974; the switching time (80 picoseconds) was too fast to measure at the time. Add 10 or 15 years: an operational Josephson computer should be demonstrated sometime between 1984 and 1989 . . . Coming soon!

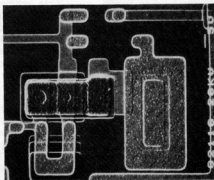

An experimental Josephson device.

Computer chronology

The rapid development of computers seems to have taken everyone by surprise – from scientists to science-fiction authors. This can be illustrated by means of a brief historical survey:

pre-1940: Mechanical computing machines existed; science fiction was more interested in robots, blandly assuming that they would be intelligent enough. In 1937, Shannon explained how Boolean logic could be applied to complex switching circuits, and in 1939 Bell labs built their Model I relay computer.

1944: The Bell labs Model III relay computer; it used 9000 relays, occupied 1000 sq.ft. and weighed approximately 10 tons. A 7-digit addition took 0.3 s.

1946: ENIAC, the Electronic Numerical Integrator And Computer, used 18,000 valves. It was a size bigger, filling a 30' x 50' room and weighing in at 30 tons. The power consumption was some 150 kW! It worked in decimal, adding 10-digit numbers in 0.2 ms (the clock frequency was 100 kHz). Multiplication took longer: 2.8 s.

Around this time, an extremely daring prophesy was made: it seemed conceivable that there might come a time when two computers would be needed in the United States for non-military use: one on the West coast and one on the East coast . . .

1952: The IBM 701 incorporated a few semiconductors: 12,000 Germanium diodes, to be precise. With its 3000 valves, 1 MHz clock, 36-bit words and 2 K word memory, it could add in 62.5 µs and multiply in 50 ms.

A few visionary SF authors were beginning to think in terms of Multivacs and Univacs. 1956: IBM discovered that some users were having difficulty with programming. They invented FORTRAN.

1961: By now there are some 5000 computers in use in the USA. Researchers postulate 'a possible future in which computational power will be available in a wall socket, like electrical power, or where every man who wants one can buy a small computer'.

Fairchild introduces the RTL flip-flop; TTL follows within the year.

1965: Digital Equipment Corporation launches the PDP-8: the first mass-produced mini-computer to sell for less than \$ 20,000. In the same year, Gordon R. Dickson put his finger on one of the distinctive features of artificial intelligence: 'Computers don't argue'.

1967: The 64-bit ROM.

1968: The 1 K-bit ROM.

1970: The PDP-11, the first CPU (Intel's 4-bit 4004) and hand-held pocket calculators.

1971: The first 8-bit CPU, Intel's 8008, costs \$ 200. The average instruction time is 30 µs.

1974: The Josephson switch operates with a switching time of 80 picoseconds, and 4 K dynamic RAMs are available. The simplest pocket calculators are going for about \$ 20, and Hewlett-Packard introduces the first

programmable calculator (the HP-65) for \$795.

1977: The TRS-80 is going for \$600. For that, you get a Z-80 based machine with 4 K RAM, 4 K ROM, keyboard, 12" screen, and cassette recorder.

now: We have 256 K RAMs and ROMs, powerful CPUs with up to 750,000 active devices on a single chip – and a flat-screen pocket TV. We have talking chips and the first steps towards speech recognition and artificial 'sight'. And we are still plagued with 'SF' films showing computers as massive cabinets and consoles, with a multitude of flashing lights and Lissajous patterns.

Coming . . . soon?

What can we expect in the next ten or twenty years? Based on past experience, it seems a fairly safe bet to start with a list of things that meet two requirements:

- available, or at least technically possible, now – even if the price is still astronomical;
- of great interest to a mass market, once the price drops far enough.

First, let's try to settle this digital audio question. Under the heading 'available now' we have ½ Mbit RAMs and ROMs; for audio recording and reproduction we would need to use some 20,000 of these ICs (assuming that we need a playing time of one hour, in stereo). This would mean about four cubic feet and a price tag that puts the whole thing out of court. Good! That satisfies our first requirement.

The second point is even more obvious: there is a huge market for this type of thing. Any mechanical system is bound to be fairly clumsy and prone to wear. Wax cylinder, vinyl LP or Compact Disc: they will all attract an equal measure of nostalgic amusement in the museums of the future.

The remaining question is: when can we expect plug-in audio cartridges? Given the trend shown in figure 1, it should take another 15 or 20 years to develop multigigabit ROMs and RAMs. Add another five years or so for the price to drop to a competitive level, and we've reached the year 2005. However, there are a few factors that may help to speed things up. In the first place, we can use a different type of memory architecture (since we don't need full random access) and this may well simplify matters for the chip designers. Furthermore, we can get things rolling with smaller ICs: we can use several in one cartridge and we can start by replacing the 45 RPM disc – with its shorter playing time. Even a 10 Mbit ROM would do, and that may well be available by 1990! Again, add at least five years for the necessary price drop.

All in all, the sequence of events could be like this:

1990: RCA creates a world-wide sensation with its solid-state juke-box, the 'Byte-ryder'. Within a month, one of Hitachi's audio-minded daughters counters with a prototype 'Rombus' player.

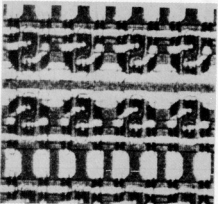
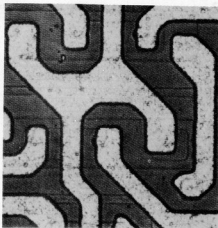

coming soon?
elektor january 1983

A decade of growth. Bipolar memories, like MOS ones, are on a track to higher density. One cell of Fairchild's 256-bit RAM (above), developed in 1970, occupies the same area as 16 cells of its 93470 4-K RAM (below). Scaled Isoplaner S will boost density another third.

1995: The first dust has settled. The leading manufacturers have reached agreement on the Compact Cartridge (although a few are still trying to perfect the Big Bubble).

Pocket players are under development. 2000: With the price now at an all-time low, Compact Cartridge players are commonplace and recorders are available. The playing-time is still on the increase.

2005: Just as everything is settling down nicely, someone comes up with a new idea . . .

Computers

Again, it is wise to start with a brief review of our current assets. Powerful CPUs are available, large memories and all kinds of interfacing devices to the human operator. For displaying data: high-resolution TV

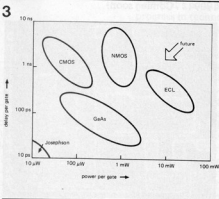

Gallium-Arsenide combines low power dissipation with a propagation delay that is an order of magnitude smaller than CMOS. The Josephson devices are that much faster again, and use only one-tenth of the power per gate!

screens on the one hand, and the pocket-sized type at the other end of the scale; printers in all shapes and sizes; and the first hesitant steps on the road to talking computers. Data entry by keyboard (mechanical or touch-pad); again, the first hesitant steps have been taken towards speech recognition and real-time entry by means of hand-written text. Communication with remote computers by telephone line – or by radio? Ultra-high-speed computers (using GaAs or Josephson devices), for applications that need them, are just over the horizon.

Let us assume that all these facilities are in full use within the next decade or so. What would that imply? Bearing in mind that human fingers are not likely to miniaturise in that period, things like a wrist-watch pocket calculator seem rather pointless. A more sensible approach would be to develop 'handy' machines that are easy to use – even without having to study a 200-page manual.

For undemanding general-purpose use: the pocket computer. Data entry by means of a simple keyboard (numerical plus a few functions); data display via a miniature TV screen. Keying and programming errors are indicated in plain language on the display. The cheap plastic case is misleading: the computing power is superior to that of a 1975 minicomputer.

Home computers. The simpler types all tend to look similar, since their shape is determined by the keyboard and display screen. 'Under the bonnet', so to speak, they differ; however, they all include outputs for telephone line and large-screen TV sets. Also, for gimmick value more than anything else, they all include a 'speech' output that can read off several dozen standard phrases. The de-luxe home computer is a different thing all together. It includes user-oriented features like speech input and output (in fact, the user will rarely feel the need to slide out the keyboard). The display screen has full-colour capability, and the speech output is extremely versatile. Furthermore, it is designed to deal with a host of 'domestic' matters on a continuing basis: light and heating control, routine cooking (and advice when you want to try something different), telephone answering and so on.

Computers for industrial and commercial use cover a wide range. Easy-to-use machines are available for routine work (speak-in typewriters, process controllers and industrial robots for mass production, answering machines for information services, etc.) At the other end of the scale, high-speed computers with dual memories (mass data store and associative) are becoming the back-bone of scientific research and development. In fact, they are being used quite extensively . . . to develop even more futuristic computers!

Microprocessors? What an out-dated phrase! Those devices are everywhere, controlling everything from ovens to sewing machines to UHF tuners, mowing machines, electric drills and children's toys. They are nothing more nor less than common-or-garden electronic devices.

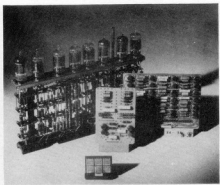

coming soon?
elektor january 1983

In the fifties, computers progressed from valves to transistors . . .

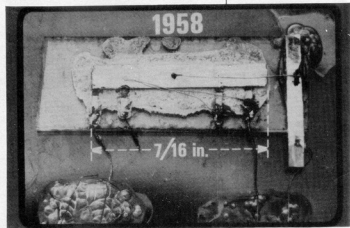

What else?

All kinds of things. Put it this way: fifteen years ago, the pocket calculator was undreamed-of. Fifteen years from now, the undreamed-of may well be commonplace. Take it from there . . .

Electronic diaries with a perpetual calendar function.

Talking encyclopedias, with an optional print-out.

One-year-ahead weather forecasts. Wrist-watch remote control units that double as car and front-door keys.

Elektor by telephone line.

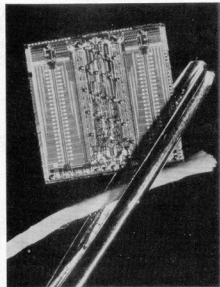

. . . then came the first integrated circuit. This has been shrinking, and the number of devices per chip has been increasing . . .

It is hard to believe that the first integrated circuit was only a few millimetres long and contained only a few dozen transistors. Today, a single chip can contain millions of transistors and other electronic components. This is the result of a process called 'shrinkage', which has allowed the number of devices per chip to increase steadily over the years. The result is a much smaller, more powerful chip that can do more things than ever before.

As the number of devices per chip increases, the size of the chip itself decreases. This is the result of a process called 'shrinkage', which has allowed the number of devices per chip to increase steadily over the years. The result is a much smaller, more powerful chip that can do more things than ever before.

. . . until we get fairly modern memory chips like this one. Note that even this is no longer 'state of the art'!

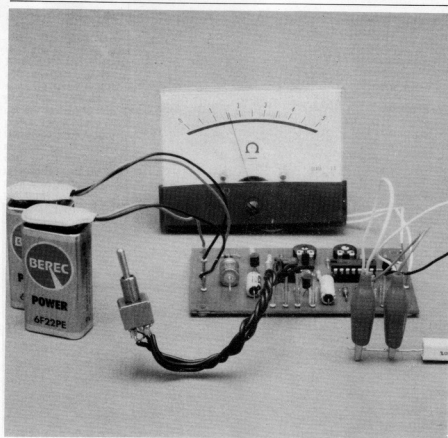

milliohmmeter

With many of the digital multimeters used nowadays, the measuring of very small resistances in the milliohm range presents certain problems. With a 'full scale deflection' of 199.9Ω , the display error after the decimal point can be 100%! This certainly leaves a lot to be desired.

For this reason, a more precise method must be applied when measuring the resistances of loudspeakers, coils, conductors (printed circuit board copper tracks) and the like. The lowest measuring range of the milliohmmeter is $0.5 \Omega \pm 1\%$ (full scale deflection), which gives us something to work with.

Let us assume that our digital multimeter has a lowest measuring range of $199.9 \Omega \pm 1\%$ deviation from the displayed value; the percentage with a displayed value of 0.1Ω can be discounted, but the specified precision of ± 1 digit means that the value read off can be 0.0 or 0.3Ω . This corresponds to an inaccuracy of 100% and becomes unacceptable. Moreover, if one takes into account the contact resistance of the plug-in connectors, the measured value becomes totally unrealistic.

Figure 1 shows how these contact resistances become part of the measurement. The sketch also indicates the manner in which a resistance measurement is nor-

a 'magnifier'
for small
resistances

1

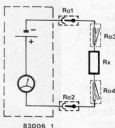

Figure 1. Using conventional resistance measurement, there are normally four contact resistances in series with the resistance to be measured.

mally performed. Resistance R_X to be measured is connected to the multimeter by means of two test leads. In series with R_X one therefore obtains four contact resistances: the plug-in connections to the instrument (R_{01} and R_{02}) and the two clip-on connections between the test leads and the resistance (R_{03} and R_{04}). Thus the value displayed by the instrument will be the sum of all contact resistances and R_X . No matter how precise the multimeter, if the value of R_X is very low than the displayed value bars no relation to the real value of R_X .

So what is the solution for obtaining reliable measurements? There is a well known measuring technique that can also be applied to measure very low resistances. The technique requires the use of a current source which provides a constant current that can flow through the resistance. The voltage over the resistance is measured with a voltmeter. Figure 2 shows a sketch of the principle. The voltmeter is connected directly across the resistance to be measured. The contact resistances R_{01} and R_{02} , the 'previous' plug-in connections between the resistance and the multimeter, no longer contribute to the measurement. Neither do these resistances affect the 'measuring current' because the latter is kept constant by the current source. All that remains are the contact resistances R_{03} and R_{04} . In relation to the internal resistance of the voltmeter, their values are so low that they can be ignored. We can therefore be satisfied that the contact resistances make practically no contribution to the resistance value measured using this technique.

Milliohm-meter adapter

Figure 3 shows a simple adapter based on the principle of the constant current source, which can be used to extend a standard multimeter into a milliohm-meter. One could call it a kind of 'magnifier'. From left to right, the circuit diagram contains a simple power supply, a voltage regulator IC 78L05 (IC1) which provides a stable supply voltage, and a current source which is based on IC2 and T1. The resistance to be measured R_X is connected in the collector line of T1. The multimeter (set to a d.c. voltage range) is connected in parallel with R_X (between the clips of the current source; see also figure 2). S1 is used to select one of two sensitivity ranges. When S1 is set to position C, the current source supplies a current of 100 mA. If a voltage of 10 mV can be read on the multimeter with sufficient accuracy, resistances down to 0.1 Ω can be measured. When S1 is set to position B the current through R is 10 mA. In this case, a reading of 10 mV on the multimeter corresponds to a resistance of 1 Ω .

This circuit can be assembled quite quickly on a piece of vero board. Precision resistors (1% tolerance) must be used for R3 and R4. T1 should be cooled on account of the high dissipation when 100 mA is drawn. Alignment is simple: set S1 to position B; substitute an ammeter for R_X and adjust P1 to obtain a current of exactly 10 mA.

2

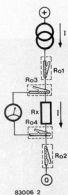

milliohm-meter
elektor january 1983

Figure 2. If a constant current flows through the resistance and the voltage across it is measured, the contact resistances have practically no effect.

De Luxe version

The only disadvantage with this method when measuring low resistances is that the set-up draws too much current. With a voltmeter sensitivity of 10 mV – or even better, 1 mV – resistances as low as 0.1 and 0.01 Ω respectively can be measured. The current required, however, is 100 mA which means that the circuit diagram of figure 3 is unsuitable for battery operation.

An efficient way of saving energy is to reduce the measuring time. Instead of passing a constant current through the resistance to be measured, short current pulses are applied. The disadvantage of this method is that inductive resistances, such as wire resistances, coils and transformer windings can no longer be measured accurately. Apart from this aspect, however, the pulse method offers considerable advantages when compared to the circuit of figure 3.

Figure 4 shows the block diagram for this method.

The current source is driven by an oscillator. Current flows through the resistance for 250 μ s, followed by an interval of 25 ms.

Although the measuring current during the pulse is 100 mA, this duty cycle results in an average current of only 1 mA.

The voltage peaks developed over the resistance are subsequently amplified by a factor of 100, so that their amplitude directly represents a measure of the value of the

Figure 3. Complete circuit diagram of the milliohm-meter using the constant current source method.

3

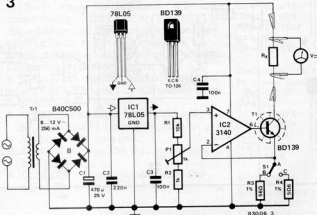

resistance. All that is now required is that the pulses be processed into a measurable d.c. voltage. A simple sample-and-hold circuit was chosen and is represented by a switch and a capacitor in the block diagram. The switch is driven by the same oscillator which switches the current source on and off. With each pulse the switch closes immediately, feeding a voltage sample to the capacitor. The capacitor C_{HOLD} is therefore charged to the same amplitude as that of the corresponding pulse. The voltage value (stored) in the capacitor is then applied to the voltmeter via a buffer stage. The observant reader will have noticed that the negative terminal of the voltmeter is not connected to ground, but to the output of the amplifier. The reason for this is that temperature deviations can cause variations in the offset voltage of the amplifier, with the result that the zero level at point A is shifted. If the voltmeter is connected between the output buffer and ground, such a shift would immediately cause a measurement error. In our case, however, any such change in the offset voltage is harmless because the level at point B is shifted to the same extent as that at point A. Strictly speaking, point A should not be taken as the reference because the pulses delivered by the current source are applied to that point for 2.5 μs . However, the resultant measurement error is only 1% and is considerably smaller than that caused by component tolerances

4

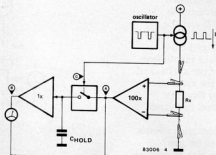

milliohmmeter
elektor january 1983

Figure 4. If the current source is switched by an oscillator, the current drawn by the circuit is restricted during the high measuring-current flow.

and lack of precision of the voltmeter. The measuring current can be increased by 1% in order to eliminate this error completely.

The circuit

Figure 5 shows the circuit diagram of the De Luxe milliohmmeter. The block diagram in figure 4 can easily be recognized here. A 7555 timer IC (IC3) with associated components serves as oscillator. The operating voltage for IC3 is stabilized by a

Figure 5. Complete circuit diagram of a milliohmmeter according to the principle sketched in figure 4.

5

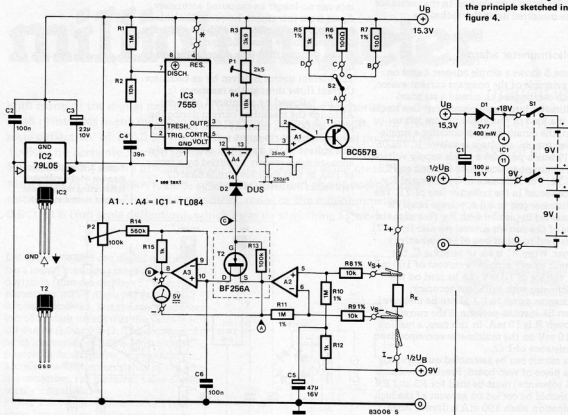

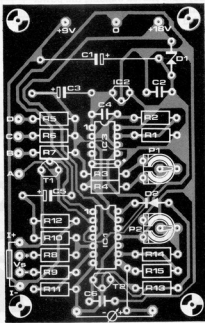
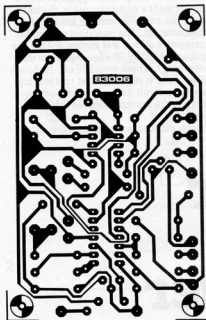

Figure 6. Track pattern and component layout for the circuit of figure 5. Terminal points I+, I-, U_{G+} and U_{G-} are connected by means of test leads to the resistance to be measured.

voltage regulator (IC2) to provide the necessary stability for the current source. The current supplied is proportional to the output voltage and is therefore also proportional to the operating voltage of IC3. The current source is composed of A1 and T1. Three different measuring currents can be selected with S2: 100 mA (position B), 10 mA (C) and 1 mA (D).

The voltage over the resistance to be measured R_X is picked off with two clips and applied to the amplifier A2 via R8 and R9. A BF 256A FET (T2) is the switch for the sampling circuit. This switch is driven by oscillator IC3 via A4. Capacitor C6 provides storage for the sample-and-hold circuit. The voltage at C6 is applied to the voltmeter via buffer A3.

Zener diode D1 ensures that the operating voltage of the operational amplifiers is somewhat higher than that of the rest of the circuit. In this way the outputs of the operational amplifiers can be fully driven to U_B , thus ensuring that the current source is switched off completely. The circuit is powered by two 9 V batteries, each supplying 10...15 mA. Variations in operating voltages have practically no effect on circuit operation. Even if the operating voltages drop to 6 V, the additional measurement error is only 0.3%. We are referring to 'operating voltages' here, because two fresh batteries must be used from the start. Incidentally, as the batteries become discharged the drop in voltages has a negative effect. The drive range becomes smaller. At an operating voltage of +6 V the value of the maximum resistance to be measured in

the 1 mA range is only 40 Ω instead of 50 Ω .

Construction and alignment

Construction of the circuit should present no problems using the printed circuit board of figure 6. Terminal points are marked, thus facilitating the connections between the board and the batteries, multimeter and so on.

Two points require particular attention. Switch S2 should be a type exhibiting the lowest possible contact resistances. A poor switch contact will cause an incorrect measuring current, particularly in the 100 mA range.

The second point concerns the test leads. To avoid confusion the four different leads should have different colours: for instance, red for I+, orange for U_{G+} , black for I- and brown for U_{G-} . The I-clips are connected to the resistance and the U_{G} -clips are also connected directly to the resistance, thus keeping contact resistances as low as possible. Calibration is relatively simple:

- Remove the wire link marked *; connect pin 4 of IC3 to pin 1 of IC3 and set S2 to position C (10 mA).
- Connect an ammeter between I+ and I- and adjust P1 for exactly 10 mA.
- Reconnect the wire link.
- Short-circuit U_{G+} and U_{G-} and connect to $U_B/2$ ($= U_{G-}$).
- Connect a voltmeter (multimeter) and adjust P2 for exactly 0 (mV). ■

Parts list

Resistors:

- R1 = 1M
- R2 = 10 k
- R3 = 3k9
- R4 = 18 k
- R5 = 1 k/1%
- R6 = 100 Ω /1%
- R7 = 10 Ω /1%
- R8, R9 = 10 k/1%
- R10, R11 = 1 M/1%
- R12, R15 = 1 k
- R13 = 100 k
- R14 = 560 k
- P1 = 2k5 preset
- P2 = 100 k preset

Capacitors:

- C1 = 100 μ /16 V
- C2, C6 = 100 n
- C3 = 22 μ /10 V
- C4 = 39 n
- C5 = 47 μ /16 V

Semiconductors:

- D1 = zener diode 2V7/0.4 W
- D2 = DUS
- T1 = BC 557B
- T2 = BF 256A
- IC1 = TL 084
- IC2 = 79L05
- IC3 = 7555

Miscellaneous:

- S1 = double-pole on/off switch
- S2 = rotary switch, 3 positions, 1 contact

Elektor readers who are hi-fi enthusiasts will no doubt have read the Crescendo article in the December 1982 edition. Some will already have started building the power amplifier. Once constructed, tested and installed in an attractive cabinet, the amplifier should operate reliably and with consistent quality for years. However, there is always a chance that a component will fail in the course of time or that some other malfunction will occur. In such cases, for example, it is possible for a d.c. voltage to reach the amplifier outputs and destroy the expensive loudspeakers.

The latter are simply not designed to cope

the amplifier outputs by means of a relay, exactly five seconds after switch-on. Secondly, it continuously monitors for an excessive d.c. voltage at the outputs. If this voltage exceeds a particular value, the links between the amplifier and the loudspeakers are disconnected. The operating voltage for the protective circuit was chosen so that the relay is immediately de-energized after the mains supply has been switched off. Although the Crescendo is still subjected to decaying voltages as a result of the large smoothing capacitors, the loudspeakers are safely disconnected.

The delay circuit also contains a special

accessories for the Crescendo power amplifier

The second part of the Elektor audio XL system contains the protection circuits for the Crescendo power amplifier. A good power amplifier must be capable of operating under all circumstances, and the Crescendo is no exception. There are some signals, however, which can damage the loudspeakers: these are mainly activation peaks (inrush surges) and d.c. voltages. To protect the loudspeakers from these hazards, every power amplifier should be equipped with d.c. protection with built-in power-up delay. These are the functions of the accessories for the Crescendo, which are also suitable for other amplifiers.

countdown and d.c. protection circuit

with this eventuality. Moreover, problems can occur when the amplifier is switched on and off. It is quite normal for a complicated circuit, such as that of a power amplifier, to require a certain time to settle down after the operating voltage has been switched on. Once all components have reached their operating temperatures, it can be assumed that the d.c. levels in the circuit are stable. When the operating voltage is switched off, there is no way of being certain how the circuit will respond. Finally, irritating sounds such as pops can be heard from the loudspeakers when the amplifier is switched on and off. These sounds are not necessarily hazardous to the loudspeakers but are usually unwanted! For this reason, high-quality commercial amplifiers almost always contain protection circuits to protect the expensive loudspeakers from power-up and turn-off peaks and unusually high d.c. voltages at the output. Obviously the Crescendo power amplifier also contains fuses, because an excess of a.c. can result in an excess of d.c.!

It is clear, therefore, that the Crescendo (and any other home-constructed amplifier without an output capacitor) should be equipped with such protective circuits. The circuit presented in this article performs two functions: firstly, it connects the loudspeakers to

feature: during the warm-up time of the amplifier the five-second countdown can be observed on an LED 7-segment display. One can therefore see when the loudspeakers are connected.

The circuits

Shown in figures 1 and 2 are the power-up delay and the protection circuits. In principle, both circuits can be incorporated separately. The only section which is common to both is the relay stage with Re1, D13, T5, T6 and R23.

The delay with its down-counter chiefly consists of ICs 1 . . . 4. IC2 is a programmable up/down counter with presettable parameters. The parameter is set to 5 by means of the J-inputs in this case. The device is also configured as a down-counter (pin 10 to ground). The clock input of this counter is driven by a square-wave generator consisting of N1, C1 and R1. When the operating voltage is switched on, IC2 is first provided with a preset pulse via network R2/C2. The value 5 is then 'present' in the counter. The square-wave generator then starts operating so that a clock pulse is applied to IC2 every second. When the counter contents become zero (5 seconds after activation), the carry-out output of the counter emits a logic 0, with

1

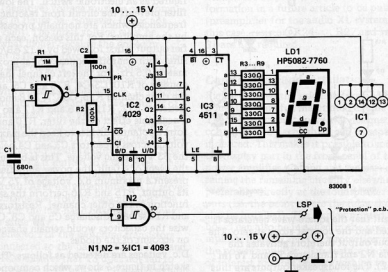

the accessories for the
Crescendo
elektor january 1983

Figure 1. This part of the circuit provides the power-up delay. The time remaining until switch-on is displayed as a count-down.

2

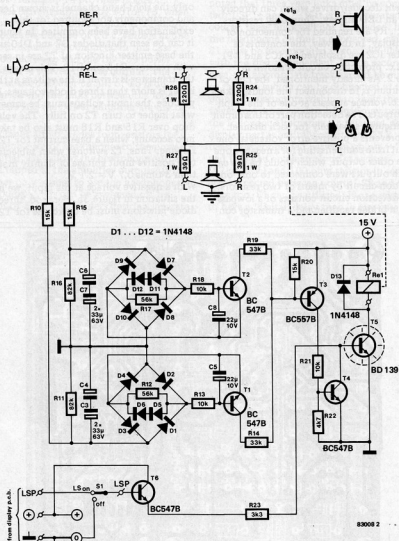
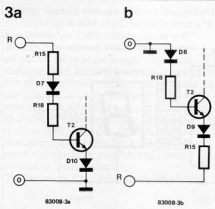

Figure 2. The d.c. protection circuit, protects the loudspeakers from hazardous d.c. voltages.

Figure 3. This figure shows the signal paths for positive d.c. voltages (figure 3a) and negative d.c. voltages (figure 3b) at the inputs of the circuit. Only the right-hand channel is shown here.



the result that the square-wave generator is inhibited and the counter stops at zero. The carry-out output therefore activates the relay via N2 and transistors T5 and T6 (in figure 2). The loudspeaker outputs are thus connected to the amplifier outputs.

The down-counting from 5 to 0 is visible on the LED display LD1. IC3 is a BCD-to-7-segment decoder/driver which can directly drive an LED display. Thus, only resistors R3 . . . R9 are required for connection of the display. In this way, the contents of counter IC2 are displayed by IC3 and DP1. The d.c. protection circuit is shown in figure 2. As already mentioned, the task of this circuit is to disconnect the loudspeakers if a d.c. voltage appears at one of the amplifier outputs. The detection point of this circuit is configured separately for each channel. This prevents a positive error voltage at one output from compensating for a negative one at the other output, which would be the case if both outputs were connected to only one detection circuit by means of two resistors. Each detection circuit consists of a lowpass filter, a bridge rectifier and a transistor con-

figured as an electronic switch. The lowpass filter prevents the circuit from reacting to frequencies which are normally processed by the amplifier. For this reason, each amplifier output is first followed by a 12 dB/octave filter with a cutoff frequency of approximately 0.5 Hz. For the left channel the filter consists of R10, C3/C4, R13 and C5, and for the right channel R15, C6/C7, R18 and C8. Resistors R11, R12, R16 and R17 also have a negligible effect on the filter. R10 and R11 form a potential divider to keep the maximum voltage across capacitors C3 and C4 below the 63 V working voltage. This is because in the event of a fault, the power amplifier can present a maximum d.c. voltage of 75 V at its output. R15 and R16 perform the same function in the other channel. Resistors R12 and R17 serve to discharge C5 and C8. Otherwise the capacitors would remain charged, on account of the diodes.

D.c. voltages are detected as follows. The sketch in figure 3 shows which components conduct in the event of an excessive positive d.c. voltage (3a) and an excessive negative d.c. voltage (3b). For the sake of clarity, only the right-hand channel is shown here and components not required for this explanation have been omitted. In figure 3a it can be seen that diodes D7 and D10 and the base-emitter junction of T2 are in series with resistors R15 and R18. This means that the transistor is driven if the voltage at the input is more than three diode voltages. In practice, the input voltage must be somewhat higher to turn T2 on fully. The voltage drop over R15 and R18 must also be taken into account, when a base current for T2 is flowing. Thus, T2 switches when subjected to a positive input voltage of slightly more than 3-times $0.7 \text{ V} = 2.1 \text{ V}$.

With a negative voltage at the input, we have the situation in figure 3b. Here too, three diode junctions must be overcome for T2

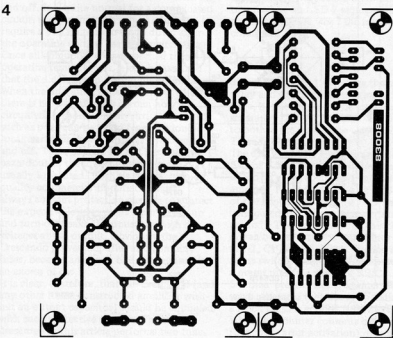

Figure 4. The printed circuit board consists of two parts: a display part and a protection part. The two can be separated if desired.

to conduct. One could assume that the same (negative) voltage must be overcome here as in figure 3a. However, this is not quite right. The input voltage must be somewhat higher because the collector current is flowing through R15 in addition to the base current. Thus the voltage drop over this resistor is somewhat higher than that with a positive input voltage. In practice, the circuit responds to negative voltages of approximately 2.6 V and higher.

The parallel circuit of D11/D12 and R17 is connected between D7/R18 and the emitter of T2. The two diodes ensure that the base current of T2 is limited to a safe level, when high d.c. voltages are applied to the input of the circuit. As already mentioned, R17 serves to discharge electrolytic capacitor C8. The circuit for the left-hand channel functions in the same way.

The collectors of the switching transistors are connected to the base of T3 via R14 and R19. R20 ensures that T3 does not fail to turn off, even if T1 and/or T2 should exhibit slight leakage current in the off-state. Transistor T4 is connected to the collector circuit of T3. Transistor T4 provides isolation for the base current supplied by T6 for T5, when the protective circuit responds. If T1 and/or T2 conducts because of a d.c. voltage at one or both inputs, T3 conducts. In this case, T4 conducts also and the BD 139 power transistor is starved of base current. The relay in the collector circuit of T5 is de-energized and the links between the loudspeakers and the power amplifier are disconnected.

The circuit also contains four resistors for matching a set of headphones to the power amplifier. This allows the headphone outputs to be tapped at the amplifier outputs. If the listener only wishes to use the headphones, the loudspeakers can be switched off by means of S1. Those readers desiring separate

headphone amplifiers will find relevant information in a future article to be published (preamplifier for the audio XL system). In this case, resistors R24...R27 and switch S1 are not required.

Construction and installation

Figure 4 shows the track pattern and component overlay for the printed circuit board. The printed circuit board was designed to consist of two parts which can be separated if desired. This makes it possible to mount the display part in the front panel of the power amplifier housing and the part containing the remaining circuitry elsewhere, preferably directly at the loudspeaker outputs (i.e. the point where the relay should also be installed). The display printed circuit board can also be installed in the pre-amplifier housing and the 'protection part' in the power amplifier. This feature should be of interest to those readers wishing to conceal their power amplifier (for example, immediately behind the loudspeaker boxes). When separating the board, it should be noted that three wire links must be connected: LSP, + and '1'. If it is not separated, of course, these links will not be needed. If the headphone output is connected, switch S1 must be incorporated in the LSP link with the first arrangement. In the second case, the appropriate track should be cut so that the switch can be connected at this point. Constructors wishing to limit themselves to a more modest budget may prefer the following alternative. In this case, the display part is entirely omitted; a 33 k resistor is connected between points '+' and LSP and an electrolytic capacitor (47 μ /16 V) and 100 ohm resistor in series are connected between points LSP and '1'. Here too, S1 can be utilized. If one wishes to have a 'digital' delay time in any case,

the accessories for the Crescendo
elektor january 1983

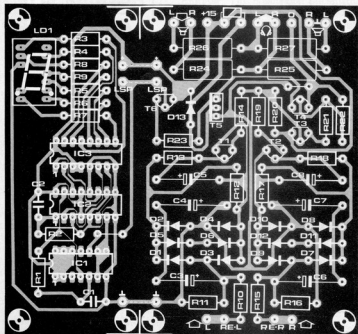

Parts list

Resistors:

R1 = 1 M
R2 = 100 k
R3...R9 = 330 Ω
R10, R15, R20 = 15 k
R11, R16 = 82 k
R12, R17 = 56 k
R13, R18, R21 = 10 k
R14, R19 = 33 k
R22 = 4k7
R23 = 3k3
R24, R26 = 220 Ω /1 W
R25, R27 = 39 Ω /1 W

Capacitors:

C1 = 680 n MKT
C2 = 100 n MKT
C3, C4, C6, C7 = 33 μ /63 V
C5, C8 = 22 μ /35 V

Semiconductors:

D1...D13 = 1N4148
T1, T2, T4, T6 = BC 547B
T3 = BC 557B
T5 = BD 139
LD1 = 7760 (common
cathode)
IC1 = 4093
IC2 = 4029
IC3 = 4511

Miscellaneous:

Re1 = relay 10...15 V/
50...100 mA,
2 normally-open contacts
10 A rms gold-plated

5

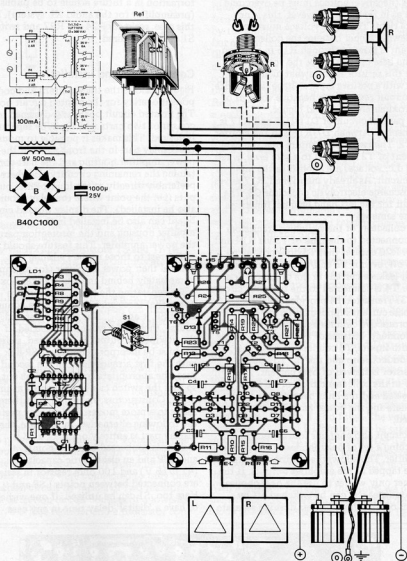

83008 3

Figure 5. This is the wiring diagram. The leads drawn with dashes relate to the headphone outputs.

only IC3, LD1 and R3 . . . R9 are omitted. The relay must be rated for a coil voltage of 12 V and must be capable of switching a *minimum* of 5 A per contact. It is well worth procuring a relay with goldplated contacts.

Connections are made in accordance with figure 5. In our example, we have assumed that the display section is separate from the main board and switch S1 is inserted.

The relay must be installed in the immediate vicinity of the loudspeaker outputs of the amplifier. This is also preferable with the protection circuit. The purpose of S1 is to switch off the loudspeakers by means of the relay, if the listener only wishes to use the headphones. The leads drawn with dashes can be omitted if the headphone output will not be installed. In this case, S1 and R24 . . . R27 are also omitted.

Under no circumstances should a large electrolytic capacitor be utilized.

After switching on the operating voltage the display shows the countdown from 5 to 0. Once the figure 0 appears on the display the relay will be energized and the display should continue to show 0. As a functional check, a 4.5 V flat battery is connected to the input for the left channel with positive to the input and negative to the circuit ground. The protection circuit should respond and the relay should be de-energized again. Remove the battery. After a short time the relay will be energized again because the fault at the input will have been eliminated. Now connect the battery with inverse polarity and the relay should be de-energized once again. This procedure should be repeated at the input for the right-hand channel. It can now be assumed that the loudspeakers are effectively protected against surges, peaks and d.c. voltages at the outputs of the power amplifier.

The many reactions to the darkroom computer described in the September and October 1982 issues are evidence of the great interest shown in this circuit. This article now describes the manner in which the darkroom computer can be connected to the well-known Philips enlargers PCS 2000 and PCS 130/150. Also shown is a method of obtaining better linearity of the thermometer, as well as an improvement to the operation of the darkroom computer by means of a small program modification.

with a contribution from H. Fietta

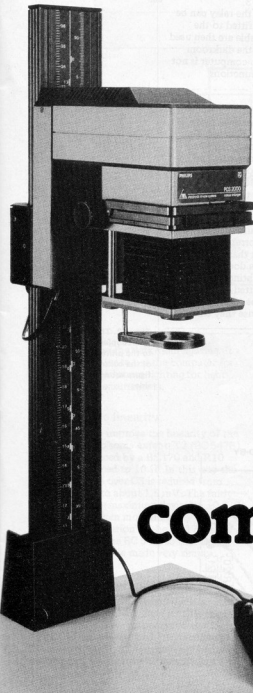

1

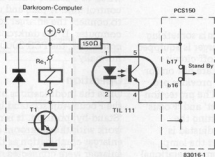

When connecting the darkroom computer to Philips enlargers PCS 130/150 and PCS 2000, the problem is that these units are equipped with built-in timers. There is therefore a risk that the built-in timer will affect functioning of the timer in the darkroom computer. Furthermore, these enlargers have a 'power-on reset'. This means that the enlarger lamp will not light up when the mains voltage is switched on. It is therefore not possible to activate the lamp using the darkroom computer via the mains plug or mains switch of the enlarger. The object of the exercise is to find some point on these units to which the darkroom computer can be connected.

Figure 1. This is how the darkroom computer is connected to the Philips enlarger/control unit PCS 130/PCS 150, using an optocoupler.

darkroom computer tips

PCS 130/150

With this type, the connection can be made very simply using an optocoupler. Figure 1 contains a sketch showing the connection between the darkroom computer and a PCS 150 enlarger using an optocoupler. Relay Re1 in the darkroom computer is replaced in this case by a 150 Ω resistor and the LED of the optocoupler. The photo-transistor of the optocoupler is now wired in parallel with the stand-by terminals of the Focus/Adjust/Stand-by switch in the enlarger. Shown in figure 2 is a section of the printed circuit board of the PCS 150, with connection points properly marked. The control unit of the enlarger contains sufficient space to accommodate the additional optocoupler. The LED terminals can be wired to a socket, thus allowing the connection to the darkroom computer to be made with a plug and cable.

PCS 2000

The PCS 2000 enlarger presents something more of a problem. This enlarger is equipped with an automatic lamp shutoff circuit which ensures that the bulbs are not on for more than 2.5 minutes. This provides protection against overheating. The protection is only required in the 'Adjust' and 'Focus' settings. In the 'Stand-by' setting the maximum time that can be adjusted is 40 seconds, which means that the lamp shutoff circuit does not become operational in this case. If one wishes to connect the darkroom computer to the enlarger, the connection must be made via the 'Stand-by' setting of the Focus/Adjust/Stand-by switch. In this case the connection must be made in such a way that the protection circuit also functions if an excessively long time is selected with the darkroom computer. The desired method of connection is made possible using a relay with two changeover contacts.

The relay must be wired according to figure 3. If one opens the housing of the control unit and views the component side of the printed circuit board, the section illustrated in figure 4 can be seen. The relay is wired in as shown in figure 4. One of the leads of R29 is snipped off and a normally-closed relay contact is wired between the two free ends. Two stranded wires are connected to pins 23 and 25 of switch SK-5 on the solder side of the p.c.b. These two wires are also routed to the relay and connected to the second (normally-open) contact as shown in figure 4 (see also figure 3).

The relay must be rated for a coil voltage of 5 V. It should also be as small as possible to facilitate installation in the control unit. A suitable relay, quoted here as an example, is RAPA type 08E-4.5-002/7, whose wiring diagram is shown in figure 3.

The two coil terminals for the relay can be wired to a socket which is fitted to the control unit. A plug and cable are then used to connect the enlarger to the darkroom computer. If the darkroom computer is not connected, the PCS 2000 functions normally.

Operation

Once the modifications have been made, set the Focus/Adjust/Stand-by switch to the 'Stand-by' position. It is now possible to work with the darkroom computer and enlarger combination as though a normal enlarger were connected. However, care must be taken not to press the timer-start button on the control unit, otherwise the times selected with the darkroom computer will not apply. The focus function can be activated either with the corresponding key on the control unit or with that of the darkroom computer. If one does not wish to switch the darkroom lighting with the computer, Rel can be omitted. In this case, however, some care must be taken with light measurements otherwise they can

2

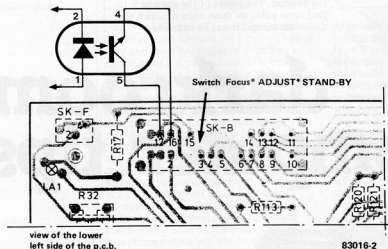

Figure 2. This is how the optocoupler is connected to the printed circuit board of the control unit. The figure shows the soldering side.

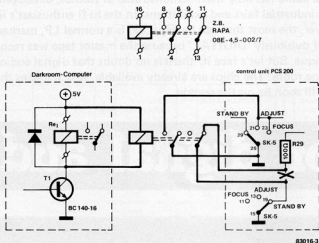

Figure 3. The PCS 2000 is connected to the darkroom computer by means of a relay with two changeover contacts.

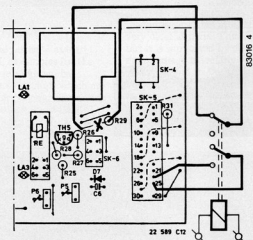

Figure 4. This is how the relay is connected to the printed circuit board of the control unit. The figure shows the component side of the board.

be influenced by the darkroom lighting. It is therefore better to use the computer for switching the darkroom lighting for light and contrast measurements.

Improving the linearity

It is possible to improve the linearity of the thermometer to some extent. T2 (BC 547B) should be replaced by a BS 170 and R10 should be reduced to 10 Ω . In this way the residual voltage over C3 is reduced from 10...15 mV to about 1.5 mV. The fairly linear response (maximum deviation +0.2°C) thus becomes even more linear.

The pin configuration of the BS 170 is the same as that of the BC 547, so that the modification can be made very simply.

Improving the second process timer

If the second process timer (which is visible on the display) is used, the fact that the first process time always reappears on the display when the timer is stopped immediately (with the START/ST button) may be inconvenient. It would be more practical for

the timer to return to the beginning of the current process time. This is made possible by a software modification which requires changing of the following addresses in the EPROM:

Address	Data
09A8	49 (previously: C9)
09AB	08 (previously: 04)
09B3	2E (previously: 5E)
09B5	5E (previously: 0A)
09B7	0A (previously: 5A)
09B9	5A (previously: 2E)

If the START/ST button is pressed whilst the timer is running it stops and the start of the current time is displayed. This is because one normally stops it when the preset time has elapsed and the buzzer is heard. If, for example, one stops the timer when the fourth time has elapsed, the start of the fifth time appears on the display. When the START/ST button is pressed again, timing continues from this point. Other controls remain unchanged.

The new program has been incorporated in the Elektor Software Service under number 514-N, thus providing the user with a choice of two different versions. ■

So far, digital audio has only been demonstrated in studios, development laboratories, industrial fairs and exhibitions. In the hi-fi enthusiast's living room, however, the most that can be expected is a normal LP, marked appealingly if dubiously 'DIGITAL' because the master tape was recorded using digital technique. But let's face it: there is no doubt that digital audio will soon be in the living room. The chips are already available, which means that the equipment will soon be on the market.

chips for digital audio

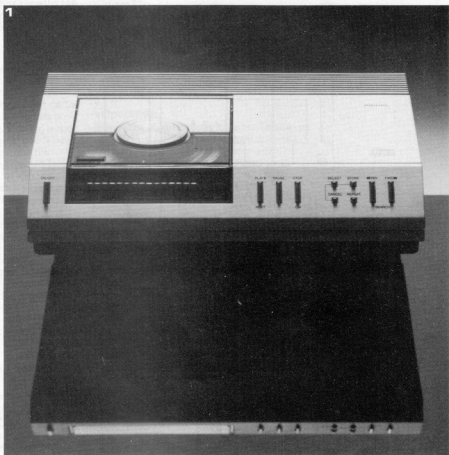

Photograph 1. The Philips CD 100 is one of the first CD players on the market.

Digital audio is not an end in itself. Until it becomes marketable, the technical advantages will be relatively unimportant. What do we mean by 'marketable'? To the semiconductor manufacturers this simply means that the technique must be suitable for applications in entertainment electronics. The marketability of digital audio is centered on one significant aspect: chips. Particularly in the field of consumer goods, it is important that the introduction of new techniques provides the equipment manufacturers with commercial advantages. For digital audio, this precondition can only be met through the use of LSI techniques. Even with the fastest microcomputers available at present, the digital processing of audio

signals can just about be executed. The demands made by digital audio techniques on signal processors are extremely high, both with respect to computing speed and complexity of the operations. This is also one of the reasons for the long wait for 'digital audio'. As far as the IC manufacturers are concerned, the demands are almost at the limit of what is economically feasible. There is no doubt, however, that this technique will soon be a vital part of entertainment electronics. Digital LSI circuits for the entire signal processing system can provide further rationalisation in production: fewer system components, automated component insertion, alignment and testing, as well as greater flexibility in adaptation

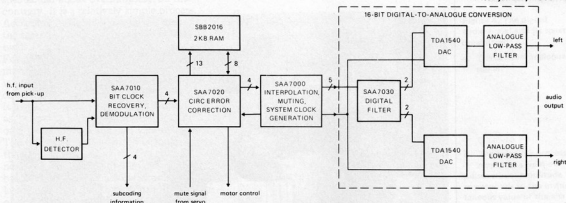

Figure 1. Block diagram of the compact disc decoder.

to the needs of the market. This last aspect is particularly fascinating. In future, model variants will require few circuit modifications, if any, and will be obtained by software changes.

The future is already here

Digital audio ICs already exist – at least from pilot production, as samples for the equipment manufacturers. As can be expected, some of these are chips which are utilised in compact disk players. Others, however, are from an unexpected field of application: the TV set!

Clearly, a digital disk player cannot be designed without digital audio ICs. Who needs a rack full of printed circuit boards under his record player, as was the case at an international electronics exhibition in 1981? In contrast, the very compact pilot-production equipment demonstrated at many international Hi-Fi-Video Exhibitions this year was already equipped with the LSI circuits developed for mass-production (see photographs 1 and 2). The block diagram of the signal processing in the CD player (figure 1) shows that a considerable number of chips on the decoder board (signal processing) are utilised for reconstitution of the digital audio information from the signal delivered by the laser pick-up. The chips in this section were specially developed for applications in the CD player and cater for high-frequency demodulation, clock recovery, extensive error correction and speed control of the drive motor. The digital audio signal played back from the disk and error-corrected is presented at the output of this CD-dedicated signal processing circuitry. Shown within the dashed lines is a two-channel, 16-bit digital-to-analogue converter, based on three ICs. This converter is one of the first, significant functional blocks for digital audio in a marketable form. This type of module is required in every digital audio system, to obtain a reconstituted, analogue audio signal at the end of the digital signal chain. Since there are no digital power amplifiers (nor digital loudspeakers!), there is no alternative to conversion back to an analogue signal. Moreover, converters for digital-to-analogue and vice versa will still be needed for a long

time, to be able to utilise digital audio components in existing, analogue hi-fi systems. One can say, therefore, that the fully digital audio system is still in the distant future.

However, digital signal processing in television sets, including the audio section, is very close at hand. This may appear strange, but it is supported by convincing economic arguments. Particularly with a colour television set and its fairly involved circuitry, the manufacturing costs can be considerably reduced through digitisation using a few LSI circuits. The advantage to the consumer is improved characteristics, such as higher reliability and a better picture and sound.

2

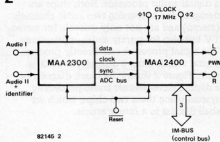

Figure 2. Block diagram of a digital preamplifier and control amplifier, consisting of a 2-channel A/D converter and an audio processor.

3

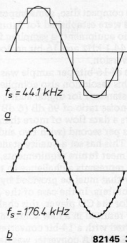
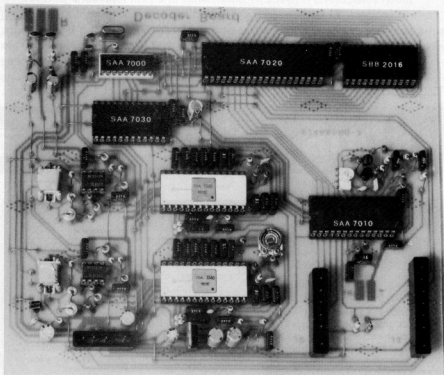

Figure 3. 4.41 kHz sinusoidal signal, sampled with 44.1 kHz in figure 3a and with four-times the frequency in figure 3b. The sampling process results in a staircase voltage which is an approximation of the original signal. The higher the sampling frequency, the closer the approximation. With the higher clock-frequency sampling rate, harmonics of the staircase signal can also be filtered out more easily.



Photograph 2. This is the most important p.c.b. of the digital recorder player. Four NMOS ICs perform most of the digital audio signal processing; this necessitates more than 4 million operations per second.

ITT-Intermetall have developed two interesting digital audio ICs for this 'digital TV set': an analogue-to-digital converter and a digital audio processor. Both chips are designed for processing two audio channels (stereo) and are not only suitable for stereo TV but also for purely audio applications. The signal processor can directly process digital signals from a disk player or tape unit. Figure 2 shows the block diagram of a digital, stereophonic audio-processing system using these two chips, which we shall discuss in a future article.

14-bit D/A converter with 16-bit characteristics

Within the compact disc, some important parameters were established for future digital audio equipment: a sampling frequency of 44.1 kHz and 16-bit analogue-to-digital conversion.

The choice of 16 bits per sample was a brave decision: this resolution also complies with the studio standard for digital audio, allows a signal-to-noise ratio of 96 dB (6 dB per bit) and delivers a data flow of more than 1.4 million bits per second (with two audio channels)! This has set a quality standard which will meet future requirements, but which also represents a challenge to the technology that must be provided by the IC manufacturers. In the case of the 16-bit converter for the CD player, this challenge apparently resulted in a new solution: 16 bits converted with a 14-bit converter. Since no 16-bit D/A converter was developed for the CD player, there is reason to

suppose that Philips originally intended to use 14 bits for the compact disc, but was 'obliged' to adopt a 16-bit system as development progressed. At any rate, the TDA 1540 14-bit D/A converter was presented in 1980. Thanks to a clever current division method, called 'dynamic element matching' by Philips, it exhibits outstanding linearity which allows a signal-to-noise ratio of 85 dB (according to the manufacturer). Dynamic element matching is a dynamic compensation method in which the errors of individual currents are eliminated by switching and mean value formation. This therefore dispenses with the very expensive laser trimming of the summing resistors with conventional D/A converters. In addition to the high linearity which corresponds to that of a 15-bit converter, the TDA 1540 also exhibits a very fast operating speed. It processes a maximum of 12 million bits per second, allowing its application in systems with sampling frequencies of up to 850 kHz, which corresponds to signal bandwidths of more than 400 kHz. This is certainly more than sufficient for digital audio!

Oversampling: greater bandwidth results in reduced noise

But let us get back to the 16-bit converter. Why develop a 16-bit D/A converter when an excellent 14-bit D/A device already exists? Maybe this was the train of thought at Philips. The fast operating speed of the TDA 1540 makes it possible to increase the signal-to-noise ratio above the 85 dB of the 14-bit converter, using a method known as

'oversampling'. There is nothing particularly spectacular about oversampling; on the contrary, it is a relatively simple process. According to Nyquist's sampling theorem, the sampling frequency must be at least twice as high as the highest signal frequency. For reasons of bit economy (why produce more bits than absolutely necessary according to Nyquist?), the sampling frequency chosen is not much higher in practice. If it is higher, however, the process is referred to as 'oversampling'. Oversampling does not only provide more bits, but also advantages. The transmission bandwidth becomes greater than the signal bandwidth. The quantisation noise is therefore distributed over a greater bandwidth and becomes correspondingly less within the signal bandwidth. In this case of the 16-bit converter in the CD player, oversampling with a factor of four is employed; the sampling frequency is increased from 44.1 kHz to 176.4 kHz. The quantisation noise is distributed over a bandwidth which is four times greater; the residual noise within the audio bandwidth is only one quarter of the original figure. Expressed in decibels, the gain in the signal-to-noise ratio is 6 dB. This brings the original 85 dB of the TDA 1540 up to 91 dB, which corresponds to the figure for a good 15-bit converter.

Oversampling provides yet another advantage. Figure 3 shows a sine wave of 4.41 kHz, sampled with 44.1 kHz in figure 3a and with four-times the frequency in figure 3b. The sampling results in a staircase approximation of the signal curve. At the higher sampling frequency this approximation is considerably closer, so that the 'staircase voltage' harmonics presented by the signal after D/A conversion can be filtered out much more simply.

This point is highly significant. Figure 4c shows the spectrum of an audio signal with a bandwidth of 20 kHz, sampled with 44.1 kHz. Theoretically, an infinite number of harmonics are produced which consist of integral multiples of the sampling frequency, with sidebands which are 20 kHz wide in each case. Of course, this wide and unfiltered spectrum must not be applied to the audio amplifier and loudspeakers. Although the frequencies above 20 kHz are beyond the audible range, they would cause amplifier blocking and would produce audible intermodulation products. For this reason, a digital audio system should attenuate all frequencies above 20 kHz by at least 50 dB at its analogue output. This task is normally performed by steep-sloped filters after the D/A converter; however, they are not a healthy business proposition because of the large number of components required and subsequent alignment. Furthermore, such steep-sloped filters do not exhibit a linear phase response in the pass band, thus resulting in impaired reproduction of pulse-type sound, according to the audio experts.

The heart of the module: SAA 7030 digital filter

In the 16-bit D/A converter of the CD player, this problem is solved with a digital module which also caters for the over-

chips for digital audio
elektor january 1983

Figure 4. The digital audio signal and its spectral breakdown:

a. The original analogue signal

b. The sampling process results in a train of pulses whose amplitude corresponds to the instantaneous value of the analogue signal (pulse amplitude modulation).

c. Frequency spectrum of such a pulse train. The sampling frequency is 44.1 kHz; the sampled signal (analogue signal) is within the audio range of 0-20 kHz.

d. Spectrum after oversampling with 176.4 kHz and digital filtering. This makes it considerable easier to filter out the frequencies above the audio range (about 20 kHz), because the sidebands with 44.1, 88.2 and 13.2 kHz are already attenuated.

e. The hold function of the digital-to-analogue converter results in further filtering with the $\sin x/x$ curve depicted; the first null point of this function is at 176.4 kHz.

f. The rest is handled by a simple analogue low-pass filter with a cutoff frequency between 30 and 40 kHz at the output of the D/A converter.

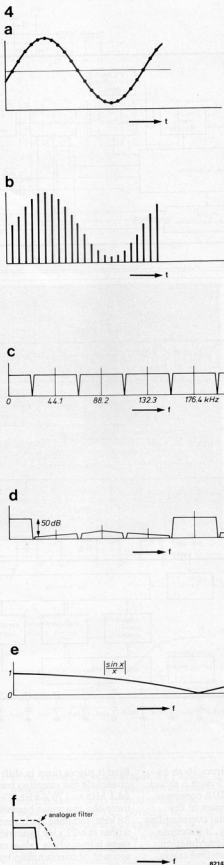

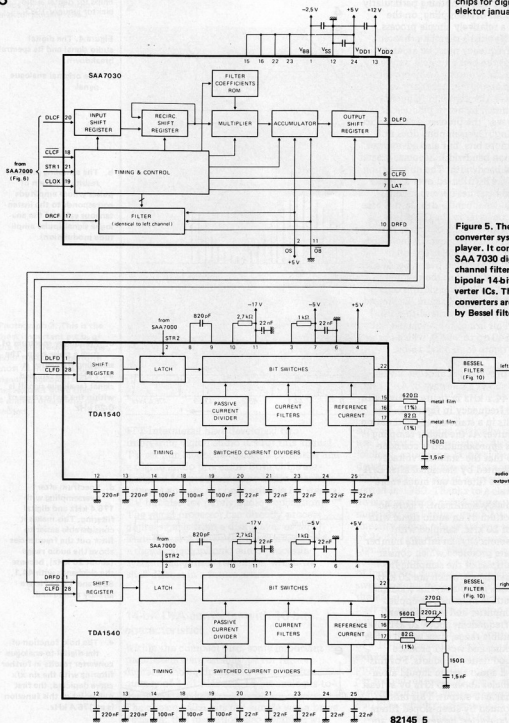
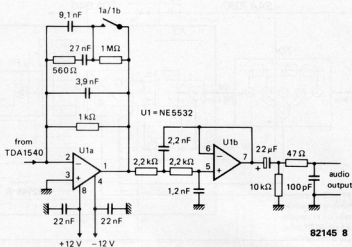

Figure 5. The 16-bit D/A converter system in the CD player. It consists of an SAA 7030 digital two-channel filter IC and two bipolar 14-bit D/A converter ICs. The D/A converters are followed by Bessel filters (figure 8).

sampling and 'rounding off' from 16 to 14 bits for the two TDA 1540s. Figure 5 shows the full circuit of the stereo D/A converter, based on the three ICs. The heart of the module is the SAA 7030 digital oversampling filter IC in NMOS technology. It processes both stereo channels. After demodulation and error-correction in the previous stages, the music is applied in 16-bit serial form to inputs DLFC and DRCF of the SAA 7030.

First it places them in shift registers which quadruple the sampling frequency from 44.1 kHz to 176.4 kHz. This also effectively increases the audio bandwidth from 22 to 88 kHz, reducing the quantisation noise within the 22 kHz bandwidth by 6 dB. The three intermediate values required on account of oversampling by a factor of four (a quadrupled sampling frequency means four samples instead of one in the same

82145 5



82145 8

Figure 8. Third order Bessel lowpass filter at the output of the TDA 1540 D/A converter. Switch 1a/1b switches a de-emphasis network into the circuit if required.

a maximum signal-to-noise ratio of 97 dB, which corresponds to that of a 16-bit D/A converter. It is therefore quite justifiable to describe the system as having a 16-bit converter, although the D/A circuit itself is only a 14-bit device. The actual task of the digital filter is to remove interfering harmonics from the spectrum of the PCM signal. The filter coefficients are selected so that the filter suppresses harmonics between the audio range and the two sidebands of the 176.4 kHz oversampling frequency. This residual spectrum around the oversampling frequency is attenuated by the hold function of the TDA 1540. The TDA converter does not present needle pulses at its output, whose amplitude corresponds to the sample value, but holds each sample until the next sample arrives. Thus the staircase voltage shown in figure 3 is produced, instead of a train of needle pulses. With regard to the effect on the spectrum of the signal, it is as though the spectrum of the PCM signal (figure 4) would be filtered with a filter with the $\sin x/x$ response in figure 4. This curve has a (first) null point at 176.4 kHz.

Prefiltering with the SAA 7030 digital filter and the hold function of the TDA 1540 allows the use of a simple third-order analogue filter to attenuate the remaining high-frequency interfering signals. In order to obtain a linear phase response, a Bessel lowpass filter with a cutoff frequency of 30 kHz and rolloff of 18 dB/octave is utilised. As shown in figure 8, the current output of the TDA 1540 D/A converter is connected to the virtual ground point at the inverting input of the first operational amplifier in the filter, so that the output filters also cater for conversion of the output current of the D/A converters to an output voltage. All the usual hi-fi equipment can be connected to the analogue audio output; the level corresponds to that of the line level of the auxiliary inputs of amplifiers.

Not only for the compact disc

This concept makes available for the first time a low-cost converter of professional 16-bit quality, based on ICs that can be mass-produced. For applications other than the compact disc, this D/A converter can also be operated with other sampling frequencies. The cutoff frequency of the digital filter remains at 0.45-times the sampling frequency and the $\sin x/x$ curve of the A/D hold function follows with its null point the sampling frequency. It may be necessary to redimension the analogue output filter only, in order to maintain the linear phase response in the passband.

Literature:

- J. Matull: 'ICs for Compact Disc Decoders', Electronic Components and Applications, Vol. 4, No. 3, May 1982, pp. 131-141.
- R.J. van de Plassche: 'Monolithic 14-bit DAC with 85 dB S/N ratio', Electronic Components and Applications, Vol. 2, No. 4, August 1980, pp. 234-241.
- D. Goedhart, R.J. van de Plassche and E.F. Stikvoort: 'Digital-to-analog conversion in playing a Compact Disc', Philips Technical Review, Vol. 40, No. 6, 1982, pp. 174-179.
- B.A. Blesser: 'Digitization of audio: a comprehensive examination of theory, implementation and current practice', JAES (Journal of the Audio Engineering Society), Vol. 26, Nr. 10, October 1978, pp. 739-771.

If one wishes to expand a fully built personal computer, the internal power supply is usually inadequate to power additional circuitry. The relatively new generation of memory chips (RAMs, EPROMs) only need a single operating voltage of 5 V. This 5 V/3 A power supply is therefore ideal for powering additional memories, peripheral devices and the like. The power supply can be built very simply using an LM 350 voltage regulator IC. Internal protective circuits against excessive load currents and temperature rise ensure that the power supply can survive considerable mistreatment.

3 A computer power supply
elektor january 1983

3 A computer power supply

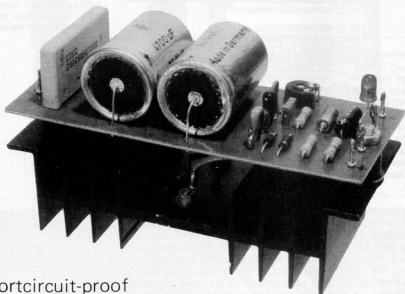

shortcircuit-proof
and protected against thermal overloads

The LM 350 voltage regulator used in this power supply has a particularly appealing characteristic: the 'common' terminal behaves as a real adjustment terminal. In contrast to the usual 3-terminal voltage regulators, the current flowing via this terminal is very low and almost independent of input voltage and load (I_{adj}). It is therefore possible to vary the output voltage by means of a simple voltage divider, without impairing the regulating characteristics.

Figure 1 shows the block diagram of such a configuration using a voltage divider. The voltage regulator develops a very stable reference voltage of 1.25 V between pins 3 and 1. This voltage produces a constant current through resistor R1 and, together with I_{adj} , a voltage is developed over R2. Thus the output voltage U_{out} is given by:

$$U_{out} = U_{ref} + (I_{adj} + U_{ref}/R1)R2 \\ = U_{ref} (1 + R2/R1) + I_{adj} R2$$

1

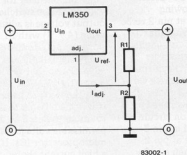

Technical data

- Output voltage: 4.7 ... 5.7 V (adjustable)
- Output current: 3 A max.
- Ripple: < 1 mV_{rms}
- Protected against shortcircuit and thermal overload

Figure 1. In contrast to the usual three-terminal types of voltage regulator, the LM 350 provides the advantage that the current I_{adj} is very low and almost independent of the input voltage and load. It is therefore possible to vary the output voltage by means of a simple voltage divider, without impairing the regulating characteristics.

As already mentioned, the (error) current I_{adj} is very low and almost independent of input voltage and load. One can therefore consider the output voltage as only being dependant on the very stable internal

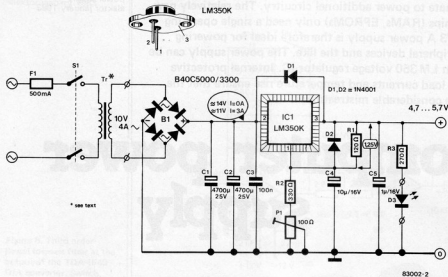

Figure 2. Thanks to the LM 350 voltage regulator, the 3 A power supply is shortcircuit-proof and protected against thermal overloads. Diodes D1 and D2 protect the regulator from voltages with inverted polarity, which could be produced by discharging capacitors.

reference voltage and the ratio between resistors R1 and R2. The value I_{adj} R2 can be discounted. The output voltage can therefore be adjusted as desired and can be made continuously variable by using a potentiometer instead of R2. In this 3A power supply a trimmer was utilized instead of R2 (P1 in figure 2). The output voltage can be set between 4.7 and 5.7 V by means of the trimmer. This arrangement allows the voltage drop over the leads to the computer to be compensated for.

The LM 350 voltage regulator is shortcircuit-proof and contains an internal protective circuit against thermal overload. The internal protection is rated to allow the regulator to deliver a current of at least 3A (shortcircuit current typically 4.5 A, depending on the device). However, the protective circuit against thermal overload does not render a heatsink superfluous: without a heatsink it would respond much too fast.

Bypass capacitors (C3 and C5) are wired at the input and output of the regulator. These capacitors also suppress any tendency of the circuit to oscillate. Capacitor C4 bypasses the regulating input (pin 1), allowing improved suppression of ripple at pin 2 to be achieved. Diodes D1 and D2 ensure that a voltage with inverted polarity is not applied to the regulator, and that the capacitors discharge through the device. If the output is shorted, diode D2 prevents capacitor C4 from discharging via pins 1 and 2 of the IC. Otherwise the latter would be destroyed before the onset of the protection circuit. Diode D1 prevents the potential at pin 3 from becoming higher than that at pin 2. This can occur, for example, when a hefty smoothing capacitor in a connected item of equipment retains a voltage for a longer period than capacitors C1 and C2, after the equipment has been switched off.

Component arrangement

The printed circuit board illustrated in

figure 3 is of the same dimensions as a 50 mm-long SK03 heatsink ($2.7^{\circ}\text{C}/\text{W}$). This facilitates construction of the power supply. The heatsink can be mounted externally at the rear of a housing, with the printed circuit board mounted internally; the same mounting holes are then used. In this case the soldering side of the printed circuit board faces the heatsink. The connecting leads to the regulator can be passed through the holes provided on it. Stranded wire with a cross-section of at least 1.5 mm^2 should be utilized for the leads to pins 2 and 3 of IC1. In any case, they must be capable of passing 3 A. Insulating mica washers and thermal paste must be used when assembling IC1 to the heatsink. The regulator must not make any electrical contact with the heatsink and/or the housing. Check this with an ohmmeter! If the power supply is to deliver a continuous current of more than 2.5 A, the bridge rectifier should also be fitted with a heatsink (bracket).

The mains transformer must be capable of supplying a current of 4 A at 10 V. Once the power supply has been built and checked for faults, the mains voltage can be switched on. The no-load output voltage is adjusted to its minimum value (4.7 V) with P1. Then connect the power supply to the computer. Switch on the power supply and the computer, and adjust P1 so that the voltage in the computer is exactly 5V. This allows the voltage drop over the leads to be easily compensated for. It is not advisable to set the no-load voltage to more than 5.5 V; as this is the maximum permissible voltage for TTL and microprocessor ICs. If a circuit which draws a high current should fail for some reason, the voltage drop over the leads will be reduced and the voltage then present on the leads may be too high for the electronic components. Should the no-load operating voltage required be higher than 5.5 V, thicker or (if possible) shorter leads have to be used and the power supply must obviously be readjusted.

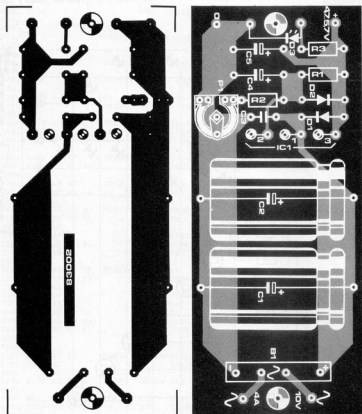

3 A computer power supply
elektor january 1983

Figure 3. The dimensions chosen for the printed circuit board are such that it can be assembled into one unit together with a 50 mm-long SK03 heatsink. The connecting leads for the regulator can be passed through the holes provided on the printed circuit board.

Parts list

Resistors:

R1 = 120 Ω
R2 = 330 Ω
R3 = 270 Ω
P1 = 100- Ω -trimmer

Capacitors:

C1, C2 = 4700 μ /25 V
C3 = 100 n
C4 = 10 μ /16 V
C5 = 1 μ /16 V

Semiconductors:

B1 = B40C5000/3300
D1, D2 = 1N4001
D3 = LED
IC1 = LM 350K TO-3 case
(National Semiconductor)

Miscellaneous:

F1 = fuse 0.5 A slow
Tr1 = mains transformer
10 V/4 A sec.
S1 = double-pole mains
switch
Heatsink 2.7°C/W,
50 mm long (e.g. SK 03)
Mica washer and heatsink
compound for IC1

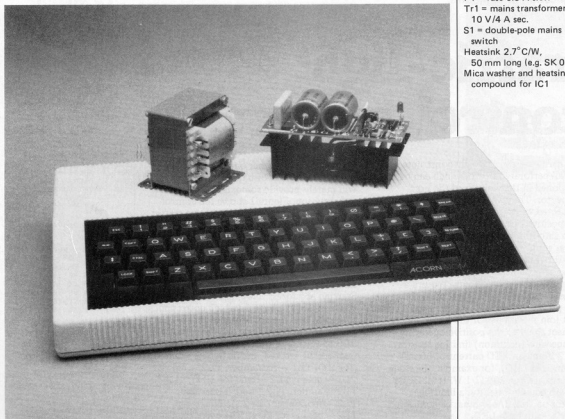

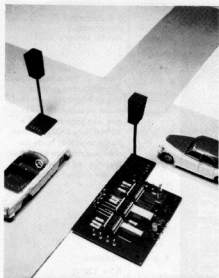

This classical task for a microcomputer, a control function which can otherwise only be implemented with a considerable amount of hardware, is executed by a program. Computers have been employed for fullscale versions of this technique for some time. This is now an opportunity to utilise the Junior Computer for the same application in miniature.

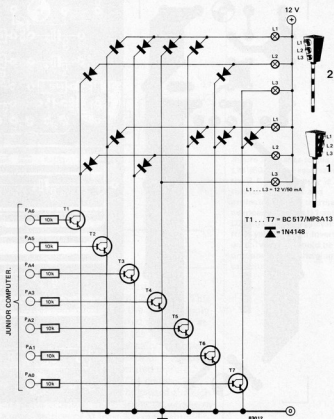

D. Herzberg

traffic - light control system...

The hardware can be easily constructed on a small perforated board, which can be positioned in the vicinity of the port connector. The two traffic lights are connected via two three-core control lines. The positive operating voltage can be taken from smoothing capacitor C5 of the basic power supply for the Junior Computer. Any other unregulated 12 V power supply is just as suitable. Bulbs with different voltage ratings will of course require a different operating voltage. Constructors who prefer to use LEDs for the traffic lights must join the anodes of the LEDs and connect them to the positive operating voltage via a (common) limiting resistor. At 12 V and an LED current of 60 mA (10 mA per LED), for example, the value of the resistor is 200 Ω /1 W. If all LEDs light up equally brightly, a limiting resistor of 1k2, 1/2 W must be connected in series with each LED.

As in the case of other circuits requiring a minimum amount of hardware, this article will merely provide some details regarding construction. Figure 1 shows the control stages for a total of six bulbs in two traffic lights, together with leads and a diode matrix which also provides a protective function. The two traffic lights are controlled by the program in table 1. The program can best be described on the basis of the Assembler listing in table 1. Starting at address 0200, the computer starts to 'shift' a logic 1 (which corresponds to a logic 0 at the collectors of the Darlington driver transistors) from PA1 via PA5 to PA0. The traffic light cycles are: traffic light 1 - red, traffic light 2 - amber (for 2 s); TL1 - red/amber, TL2 - red; TL1 - green, TL2 - red (for 10 s); TL1 - amber, TL2 - red; TL1 - red, TL2 - red/amber (for 2 s); TL1 - red, TL2 - green (for 10 s). The cycle then starts

... with the Junior Computer

```

0010: 0200          ORG 02000
0020:
0030:
0040:          TRAFFIC LIGHT SIMULATION WITH THE JUNIOR COMPUTER
0050:
0060:
0070:          WRITTEN BY DIETER HERZBERG BERLIN
0080:
0090:          DEFINITION OF ADDRESSES
0100:
0110: 0200          PA * $1A80 PORT A DATA REGISTER
0120: 0200          PADD * $1A81 PORT A DATA DIRECTION
0130:
0140: 0200          TIMERD * $1A97
0150: 0200          END * $1A85
0160:
0170:
0180: 0200 A9 7F    START LDAIM $7F  INITIALIZE PORT A
0190: 0202 8D 81 1A STA  PADD
0200:
0210: 0205 A0 02    LOOP  LDYIM $02  LOOP COUNTER
0220: 0207 8C 80 1A STY  PA        BEGIN WITH PHASE 1 =A1:RED/A2:AMBER
0230:
0240: 020A 20 2F 02 NEXT  JSR  SHORT  WAIT FOR 2 SECONDS (PHASE 1+2)
0250: 020D 0E 80 1A ASL  PA        PHASE 2+3
0260: 0210 88
0270: 0211 D0 F7    BNE  NEXT
0280: 0213 20 2C 02 JSR  LONG    WAIT FOR 10 SEC. AT PHASE 3
0290: 0216 A0 02    LDYIM $02  PHASE 4+5
0300:
0310: 0218 0E 80 1A NEXTA ASL  PA
0320: 021B 20 2F 02 JSR  SHORT  WAIT FOR 2 SEC. (PHASE 4+5)
0330: 021E 88
0340: 021F D0 F7    BNE  NEXTA
0350: 0221 A9 01    LDAIM $01  PHASE 6=PHASE 1
0360: 0223 8D 80 1A STA  PA
0370: 0226 20 2C 02 JSR  LONG    WAIT FOR 10 SEC. AT PHASE 1
0380: 0229 4C 05 02 JMP  LOOP
0390:
0400:
0410: 022C A2 20    LONG  LDXIM $20  DELAY FOR 10 SEC.
0420: 022E 2C      = $2C
0430:
0440: 022F A2 08    SHORT LDXIM $08  DELAY FOR 2 SEC.
0450:
0460: 0231 A9 F4    LOAD  LDAIM $F4  250 MS
0470: 0233 8D 97 1A STA  TIMERD    DIVISION FACTOR 1024 MS
0480:
0490: 0236 2C 85 1A TIMEND BIT  END  TIME OUT?
0500: 0239 10 FB    BPL  TIMEND  NO
0510: 023B CA      DEX
0520: 023C 10 F3    BPL  LOAD    YES LOAD TIMER WITH 2ND DELAY
0530: 023E 60      RTS
0540:
0550:
0560: 023F A9 7F    US  LDAIM $7F  ONLY IF LIGHTS ARE OUT OF ORDER
0570: 0241 8D 81 1A STA  PADD
0580: 0244 A9 40    LDAIM $40
0590:
0600: 0246 8D 80 1A PORT  STA  PA        BOTH AMBER LIGHTS FLASHING
0610: 0249 A2 04    LDXIM $04  1 SEC. ON/OFF
0620: 024B 20 31 02 JSR  LOAD
0630: 024E AD 80 1A LDA  PA
0640: 0251 49 40    EORIM $40  INVERT PORT
0650: 0253 4C 46 02 JMP  PORT
0660:

```

SYMBOL TABLE 3000 3054

```

END 1A85 LOAD 0231 LONG 022C LOOP 0205
NEXT 020A NEXTA 021B PA 1A80 PADD 1A81
PORT 0246 SHORT 022F START 0200 TIMEND 0236
TIMERD 1A97 US 023F

```

JUNIOR

M

HEXDUMP: 200,255

```

0 1 2 3 4 5 6 7 8 9 A B C D E F
0200: A9 7F 8D 81 1A A0 02 8C 80 1A 20 2F 02 0E 80 1A
0210: 88 D0 F7 20 2C 02 A0 02 0E 80 1A 20 2F 02 88 D0
0220: F7 A9 81 8D 80 1A 20 2C 02 4C 85 02 A2 28 2C A2
0230: 08 A9 F4 8D 97 1A 2C 85 1A 10 FB CA 10 F3 60 A9
0240: 7F 8D 81 1A A9 40 8D 80 1A A2 04 20 31 02 AD 80
0250: 1A 49 40 4C 46 02

```

JUNIOR

again from the beginning. Another traffic light cycle is simulated with start address 023F. In this case the two amber bulbs flash at a 1 s rate. PA6 is utilized for this. The hex dump listing shows a summary of the data

to be entered. In the event of a computer fault, the diodes ensure that at least one traffic light is at red, thus preventing a traffic jam. Accidents are also almost ruled out.

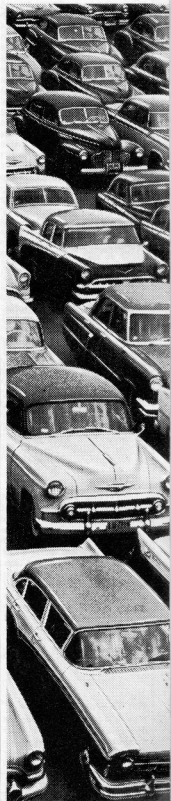

showing potentiometer P2, which is used to adjust the output voltage. The relationship between potentiometer value and output voltage in this case is very simple: 1 V output voltage per kilohm. To set the adjustment range to precisely 25 V, the resistance value of the potentiometer at its maximum must be as close to 25 kilohm as possible. Before going out to hunt for an extremely expensive, precision potentiometer, one should consider adapting P2 as follows: Use a 47 k potentiometer for P2 and connect a 100 k trimmer in parallel (see figure 2b); with the

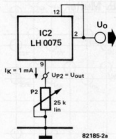

Figure 2a. Section of circuit of a precision power unit with an LH0075. The value of P1 determines the highest output voltage and should be as close to 25 k as possible.



Figure 2b. The value of the potentiometer can be set precisely by connecting a trimmer in parallel.

potentiometer set to its maximum, adjust the trimmer to obtain an output voltage of exactly 25 V. As usual, there are also disadvantages:

1. The relationship between wiper travel of the potentiometer and output voltage is no longer linear (no problem in this case, because the voltage is indicated by the integral voltmeter).
2. If the potentiometer is used as a voltage divider, a greater resistance value also signifies higher internal resistance (not applicable in this case, because the potentiometer is connected as a variable resistor).

If the resistor of the potentiometer is only slightly higher than its rated value (i.e., up to +20%), the exact value can be obtained by adjusting a trimmer of a considerably higher value (factor of 10-20) in parallel. The disadvantages mentioned no longer apply, because the linearity and internal resistance only vary slightly.

Operating life using a 9 V battery

Small circuits with a low current consumption are often powered by a 9 V battery (IEC6F22). In the descriptions of these circuits one sometimes encounters an approximate figure for the service life of the battery. How are these figures obtained?

This is a good question, considering that the capacity is not indicated on the battery not on its packaging. However, one can find the data in the manufacturers' technical literature, at least for alkali-manganese batteries; for example, in the very interesting 'Duracell guidelines' from Mallory. The rated capacity quoted is 500 mAh when discharged over a 750 Ω resistor, down to a terminal voltage of 4.8 V. The diagram shows the voltage curves for

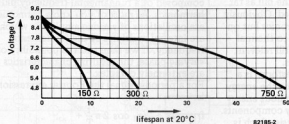

Figure 3. Typical discharge curves for a 9 V alkali-manganese battery (Mallory, IEC6LF22).

various loads. The capacity figures for 'normal' 9 V batteries, i.e. zinc-carbon systems, are not so clear. Their service life (available capacity) greatly depends on storage life, discharge current and type of discharge. However, in order to be able to make a qualitative statement, there are discharge tests specified by IEC, e.g. the illustrated 'pocket calculator test' which specifies a daily



discharge of 30 minutes over a 180 ohm load resistor. The standard 9 V battery tested here provides nearly 6 hours of operation with a terminal voltage of 5.4 V. The capacity of a 'super dry battery' is slightly more than 8 hours in this test. In a 'radio test' (4 hours daily into 900 ohms) the operating life is approximately 40 hours (standard) and 50 hours (super). As estimates of capacity in mAh one can take approximately 200 to 350 for the pocket calculator test and 300 to 400 mAh for the radio test. In the case of a continuous discharge with high currents (e.g. into 180 ohms) on the other hand, not much more than

50 mAh can be expected because the battery does not have an opportunity to regenerate during intervals.

Data and pin assignments, standard semiconductors

Elektor uses the same type designations in all editions for the standard semiconductors of the various manufacturers; for example, 741 instead of μ A 741, LM 741, RC 741 and so on. The manufacturers' identification letters are dropped. This can be found under the heading 'Decoder' in every edition of Elektor. Sometimes, however, there are deviating characteristics (data) in addition to the manufacturers' letters. Are these also dropped? The answer is yes. If we specify a 'neutral' type designation, it means that the circuit is designed for the version with the 'more modest' data (e.g. smallest supply voltage range). If one uses an IC with improved characteristics from another manufacturer, there are no problems. Obviously the pin assignments must be the same! A little care must be taken with the 'TUPs' and 'TUNs' (terms created by Elektor). Not all transistors of the BC family, whose data allow them to be used as TUP or TUN without any problems, have the same pin assignments. Those types indicated in 'Decoder' can be relied on. This only applies to cases in which the manufacturer keeps to the 'Pro-Electron' agreement, which is not always the case. We recently came across a BC516 with interchanged electrodes. Fortunately the manufacturer had marked the electrodes, so that one could at least identify them (during fault-finding, of course!).

Figure 4. Typical discharge curve for a standard 9 V zinc-carbon battery (IEC6F22) in the 'pocket calculator test' of IEC: daily discharge of 30 minutes over a 180 ohm load resistor.

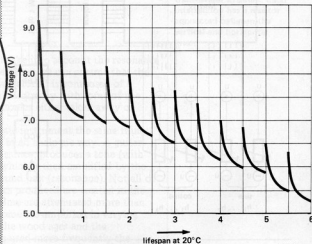
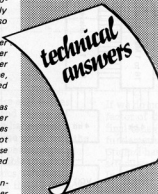

Fourier synthesis

In 1822 a french mathematician came forward with an interesting mathematical expression which seems to fit the bill as far as sine-wave forms are concerned. Obviously his thoughts were not on electronics but on the complex problems relating to thermal conduction. Even so they are still relevant today in the field of electronics. By definition the 'Fourier Transform' is a mathematical expression relating the energy in a transient to that in a continuous energy spectrum of adjacent frequency components. This gives us the Fourier Analysis which is termed as a method for determining the harmonic components of a complex periodic wave function. Conversely the principles can be applied to create wave-forms, ideal for music synthesizers. With the help of a few examples we will explain how to apply the theory to produce exactly the wave-form wanted. The article does not go so far as to show actual working circuits, but sticks to block diagrams which

should stimulate the urge to experiment. Complex sound waves (sine waves) are composed of a fundamental frequency plus harmonics. As most of you know harmonics are oscillations of varying amplitude which are integral multiples of the fundamental frequency. If we then add the possibility of varying phase, the resulting characteristics are extremely complex. For a periodic signal the Fourier expression is:

$$f(t) = a_0 + 2(a_1 \cos 2\pi \frac{t}{T} + a_2 \cos 2 \cdot 2\pi \frac{t}{T} \dots) + 2(b_1 \sin 2\pi \frac{t}{T} + b_2 \sin 2 \cdot 2\pi \frac{t}{T} + \dots)$$

In a more compact and simpler form:

$$f(t) = a_0 + 2 \sum_{h=1}^{\infty} [a_h \cos 2\pi \frac{t}{T} + b_h \sin 2\pi \frac{t}{T}]$$

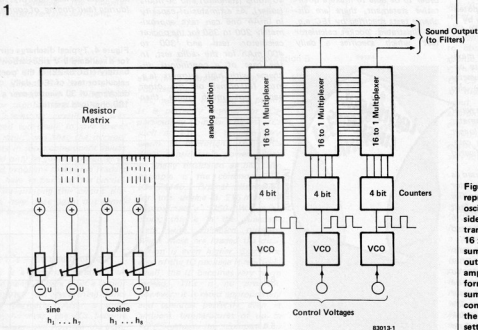

Figure 1. A block diagram representing a Fourier oscillator. On the left hand side is the Fourier transformer consisting of a 16 x 16 matrix and a summing amplifier. At the output of the summing amplifier appears a wave-form comprising of the sum of the sine and cosine components determined by the potentiometers settings. The multiplexer ensures the frequency is one determined by a VCO.

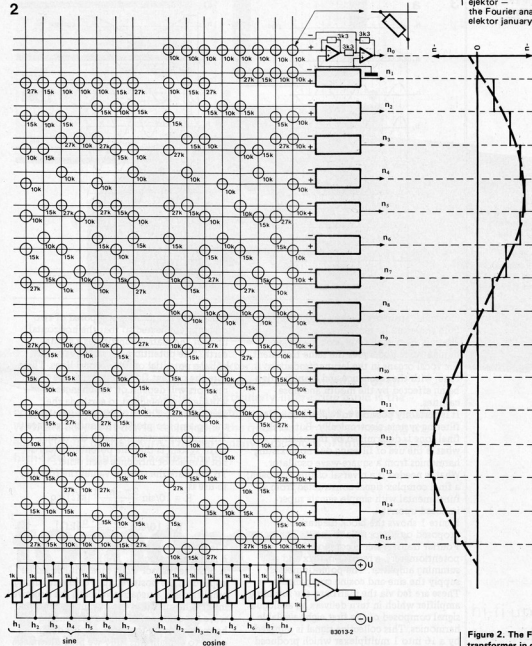

Figure 2. The Fourier transformer in detail. Each intersection has a resistor connected between the vertical and horizontal lines.

It is possible to extend these expressions infinitely in terms of sine and cosine components. In effect each harmonic conforms to a sine and cosine term, with the amplitude determining the phase relationship. It is theoretically possible to add an infinite number of harmonics, but that would need a piece of paper three miles long or more! In practice we have to restrict the situation using a more realistic number: eight or so.

Music synthesisers make good use of the Fourier principle; a sound source (oscillator) produces a signal with a certain number of harmonics, some of which are then taken out by a voltage controlled filter (VCF).

If we do not take into account the resonance factor of the filters we can assume that the final tone (waveform) is composed of a fundamental frequency with some of the original harmonics either taken away or attenuated.

In any acoustic instrument the same thing happens but in an analogue way. A guitar string, for instance, produces a tone (with harmonics) which is then amplified by the wood and sound box (resonance). Not all of the harmonics produced are treated in the same way; some are attenuated more than others and some are amplified in varying degrees. As the wood ages and the instrument is used more frequently the

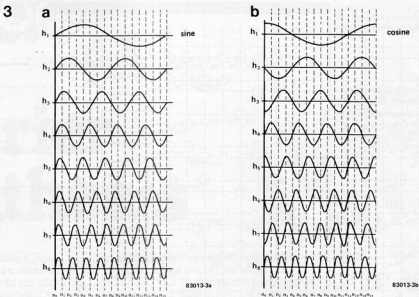

Figure 3. The sine (3a) and cosine (3b) components of the 16 outputs of the matrix. When the sine curve of the eighth harmonic (h_8) crosses the zero point there is no result produced at the outputs.

molecular structure of the wood changes (and therefore its resonance factor), in turn altering the overall tone produced. The human voice undergoes the same treatment; the vocal organs in the larynx produce a tone, with the resonance and amplification being effected by the mouth and nose cavities.

It is certainly possible to realise a complex filtering system electronically. But, as the final tone is determined by the original, what is the use of filtering out non existing harmonics from a square-wave oscillator. What is needed is a reversal of this approach; a final complex signal constructed from a fundamental with simple signals superimposed upon it.

Figure 1 shows the block diagram of a proposed oscillator 'a la' Fourier. The static Fourier transformer is composed of potentiometers, a resistor matrix and a summing amplifier. The potentiometers supply the sine and cosine components. These are fed via the matrix to the summing amplifier which in turn delivers an analogue signal composed of the first eight available harmonics. This collective signal is sampled by a 16 into 1 multiplexer which produced the definitive waveforms needed. The multiplexer is controlled by a square-wave signal generator (VCO). In other words the final signal is not determined by the Fourier transformer but by the frequency of the VCO. To obtain a chorus effect quite a few multiplexers and VCOs are required, the signals being further processed by voltage controlled filters (VCFs) and envelope generators (ADSRs).

Figure 2 shows the resistor matrix in greater detail. Each intersection has a resistor connected between the vertical and horizontal lines. The matrix is arranged so that 16 inputs results in 16 transformed outputs. This allows the possibility to create 8 harmonics of differing amplitude and phase, each being independent of the others. The sine and cosine functions (terms) are summed to produce a composite analogue

signal. The amplifier is composed of two op-amps connected so that the horizontal lines of the matrix constitutes a virtual earth. The potentiometers only vary the voltage potential on the vertical lines. Therefore the current flowing through the resistors will depend on the changes in voltage level being fed to earth via the vertical lines. The currents are summed by the op-amps to produce an output voltage. The great advantage of using the virtual earth system is that the potentiometers do not interact or influence each other. To calculate the resistor value the formula to use is:

$$R = 10/\sin \frac{2\pi \cdot h \cdot n}{16} \text{ [k}\Omega\text{] c.q.}$$

$$R = 10/\cos \frac{2\pi \cdot h \cdot n}{16} \text{ [k}\Omega\text{]}$$

n is the channel number (0 . . . 15).

h is the harmonic (1 . . . 8).

A positive resistor value means it should be applied to the positive input of the summing amplifier and a negative value to the negative input. The circuit at the output gives a sine-wave (or a cosine) of the corresponding harmonic having the same amplitude. In order to explain this fully we have drawn the sine component of the first harmonic at the output. By varying the setting of several potentiometers we produce the sum of a number of sine and cosine components. Figure 3a represents the sine, and 3b the cosine parts of a harmonic (h_1 . . . h_8). The potentiometer controlling the sine- h_8 can be omitted. The individual waveforms of the 16 channels will then intersect the zero point of the h_8 harmonic with no result being produced at the outputs.

How to use the Fourier oscillator is left to the readers discretion as this article is meant as an introduction to the theoretical aspects from which experimentation can grow. The potentiometers can be replaced by other types of voltage sources (fixed or variable). With this in mind we suggest the use of the graphic oscillator circuit from the Elektor summer circuits issue 1982 Nr. 7-48. ■



The January edition of Elektor traditionally examines future trends and is something of an 'Elektoracle'. A particularly interesting topic is the continuing change in the field of entertainment electronics, especially audio. With the advent of digital techniques, the question is raised concerning the audio system of the future. There are many indications of future trends in high-fidelity techniques and technology.

tomorrow's music

The main factors affecting the change in hi-fi equipment techniques are: the market, current and future legislation and, last but not least, the electronic components industry with its innovative attitude.

This last factor is obviously the one that interests us the most. The advances in semiconductor techniques allow us to progress from the existing, digital control of many audio components, such as cassette recorders and FM tuners, to digital signal processing. Apart from the hardware in the form of electronic circuitry, the software now plays a part for the first time. Thus, for example, it is now practically impossible to build an FM tuner without software because all present tuning systems (fre-

quency synthesisers) contain a micro-processor.

However, it is also true that the influence of the market and legislation on future audio techniques should not be underestimated. Experience shows us that the consumer by no means always accepts what the electronics specialist admires. The influence of legislation on technical developments becomes increasingly obvious. The future for video text, satellite reception, cable television and wideband communications largely depends on legislation, apart from the 'indirect' influencing factors such as standards and test requirements. This is therefore the framework for the future development of high-fidelity.

hi-fi up to
the end
of the century

Figure 1. As the track width decreases the use of the compact disk becomes possible.

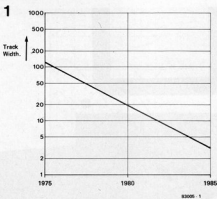

PCM — a basic innovation

The 80s are already the decade of digital audio techniques. Now that the microprocessor has extensively taken over the control of functions in equipment, it is tackling the processing of the 'useful signal'. With the digital encoding of analogue signals, known as pulse code modulation (PCM), music becomes digital information like any other as far as the microprocessor is concerned. This is made possible by analogue-to-digital converters. Fast and powerful microprocessors handle this information in various ways: computing, storage, shifting back and forth. Since, to put it simply, computers do not make mistakes, the quality that goes in has to come back out; and that means without defects and distortion. Faults created in other 'departments' such as signal transmission by radio and cable or during storage on tape or disk, can be corrected. These advantages which have been exploited for a long time in commercial telecommunications are now becoming accessible to audio systems. The final result will be a fully digital cascade: from the microphone in the recording studio, right up to the loudspeaker in the living room.

Figure 2. A stereo digital system.

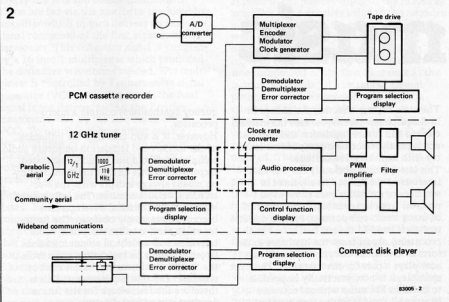

Tape and disk

It all started with the video recorder which evolved into a digital tape recorder, thanks to the PCM adapter. At present this is still the most widely used digital audio equipment available, but the scene is changing rapidly. The digital audio disk is now with us. The Compact Disc, which is a development of the 'Laservision' video disk, provides one hour of stereo with a signal-to-noise ratio of > 90 dB, channel separation > 90 dB, distortion factor < 0.01%; wow and rumble are zero. See table 1 for a comparison: Signal-to-noise ratios of the components involved in a VHF radio transmission, including studio equipment! The video recorder with PCM adapter as a recording and playback medium is only a temporary solution which is unlikely to survive for very long. One reason is that digital cassette recorders (both video and audio), are already in development and some Japanese manufacturers have already presented or announced their prototypes. In fact cigarette sized video recorders are already available in limited numbers. These PCM cassette decks use the well-proven compact cassette. In any case, vertical heads and longitudinal recording are employed, as with a normal cassette recorder. To begin with they will have up to 18 parallel tracks and a tape speed of 9.5 cm/s, which is twice the present standard. However, a study of the development of the head and tape technology used in video recorders (figure 1) allows one to draw the conclusion that it will be possible to record PCM signals in 'compact disc

Microphone	70 - 75 dB
Mixing console	60 - 70 dB
Studio tape unit	54 - 58 dB
Record player	up to 70 dB
Direct-recording disk	72 - 76 dB
Modulation line	60 - 66 dB
VHF transmitter	60 - 65 dB
Hi-fi stereo tuner	60 - 65 dB

quality' on a compact cassette at the standard tape speed of 4.75 cm/s. This will involve the use of special heads for so-called vertical magnetisation with only one, or possibly two, tracks per winding direction. Operation of digital cassette decks is considerably simpler than the analogue type. The many 'mimics' for recording level, premagnetisation, equalisation characteristics, noise suppression is dispensed with.

Digital stereo radio

The present FM transmission system in the VHF region as far as audio quality is concerned leaves a lot to be desired. Some thought has been given to the possibility of digital audio-signal transmission in the VHF region, without changing the standard bandwidth. A change in transmission standards for VHF transmitters seems very improbable, on account of the question of compatibility with the millions of existing VHF receivers. The first step will therefore be digitisation of the VHF tuner, as is already the case with digitisation of the signal processing in television sets. The only part of a receiver that will still use analogue techniques will be the tuner. Demodulation and stereo decoding will be performed by a digital processor. It can be expected that this technique will improve the receiver with respect to distortion factor, noise and channel separation. Digitisation also helps to eliminate interference caused by multipath reception. Quality problems, however, will still be found at the VHF transmitter and modulation lines. Stereo radio programs may soon be available via satellite transmission, community aerial systems or wideband cable networks (fibre-optic cables). A single 12 GHz satellite channel with TV bandwidth can carry up to 16 stereo radio programs, and a single TV satellite has five of these TV channels. The PCM tuner required for reception of these digital radio transmissions will then finally be the 'real' digital tuner, which will offer its owner the audio quality of the new digital era, together with every conceivable refinement (gimmick), such as voice-actuated command input.

Digital amplifiers

The digital amplifier of the future will consist of a fast signal processor which, with software support, will replace all classical controls such as volume, balance and tone, and a switching output stage. The latter will be in class D, better known as a PWM amplifier. The processor will perform the conversion from PCM to PWM. On account of the problem presented by spurious emission from switching output stages, it is likely that the amplifier will be installed in the loudspeaker box (active box). The future will also provide a solution for loudspeaker cables: fibre-optic cables. Of course, digital fans are not satisfied with the analogue PWM output stage (the information is contained in analogue form in the pulse width). They are

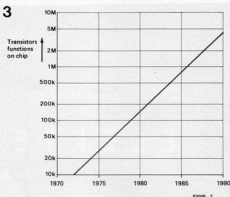

tomorrow's music
elektor january 1983

Figure 3. The ever increasing number of functions per chip.

dreaming of a digital-to-analogue power converter as an output stage.

The missing links: digital loudspeakers and microphones

The analogue technique still seems to be the only one available for the beginning and the end of the audio system: no digital principle has yet been presented for microphones and loudspeakers. What is even worse is that the microphone preamplifier is also analogue and decisively affects the signal-to-noise ratio of the digital audio signal. A consolation is that analogue amplifiers are available with a signal-to-noise ratio of 100 dB.



The weak points still remaining are the loudspeaker, the room and listening habits (and facilities) of the consumer in his own four walls which are more or less permeable as far as soundwaves are concerned. The dynamic range of 85, 90 or more dBs offered by the signal is defeated here. Perhaps dynamic compressors (digital, of course) will become popular because the maximum volume that is practical in a living room prevents the listener from hearing the quiet music passages!

The real future: music semiconductors

Almost all the components indicated in figure 2 can already be found in development laboratories. This includes, for example, the laser disk which can be used for recording and playback, and which could become a competitor to the digital cassette recorder. The real future lies in semiconductor music memories. RAM and ROM instead of disk and tape.



D. Paulsen

Page extension for the Elekterminal

Elekterminal width extender

High-speed readout for the Elekterminal

These are some of the extensions that were added to the Elekterminal since its introduction (1978). Now the ELEKTERMINAL becomes an elekterminal. Continuing with the series of extensions, this article presents lower-case, special characters and as a matter of interest, the umlauts for German and other languages (ä, ö, ü).

lower-case and special characters on the Elekterminal

The Elekterminal was originally developed as a refinement for the '78 BASIC computer. This SC/MP BASIC system has a Tiny BASIC interpreter which can only handle upper-case and is relatively slow. Recent computer systems, such as the Junior System with BASIC Version 3.3 make greater demands of a terminal.

Change of IC

The character set of the Elekterminal is located in ROM IC11 = RO-3-2513 CGR-001. A total of 64 ASCII characters can be displayed in a 5 x 7 matrix with this character generator. So far these 64 characters have only been upper-case, with a few ASCII special characters.

Conversion to upper-case and lower-case is mainly achieved by replacing IC11 by a type 2716 EPROM. This IC must be programmed according to the hex dump in table 3 in order to contain the codes for displaying a total of 96 ASCII characters.

+ 1 bit

In order to display 64 ASCII characters the screen memory merely requires a width of 6 bits ($2^6 = 64$). For 96 characters, however,

an additional bit is needed. Since this bit must also be stored, another 1024 x 1-bit memory IC must somehow be accommodated on the printed circuit board. Moreover, after readout from the RAM area, this seventh bit must be buffered. Since IC9 only has space for 6 bits, a TTL IC is required in order to solve the problem.

Thus three new ICs are needed to display 96 characters: a 2716 instead of the old IC11, an additional RAM IC of type 2102A4 and a flip-flop from a 74LS74.

Lack of space?

Where can the three ICs be accommodated? For the 2102 the answer is simple: this IC is simply soldered onto IC4 in piggy-back fashion, except for pins 11 and 12. Before soldering, these two pins are spread and later wired to the other ICs.

The best solution for the 2716 and the 7474 is to place them on a small perforated board. This additional board is soldered to the main board instead of the former IC11, using stiff wire.

Pin 12 of the additional RAM IC is connected to pin 2 of the 7474; pin 11 is connected to point B5 on the board (see circuit diagram in figure 1).

2

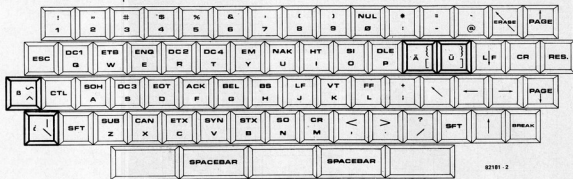

Figure 2. The ASCII keyboard of the Elektor terminal. Two keys must be added here.

3

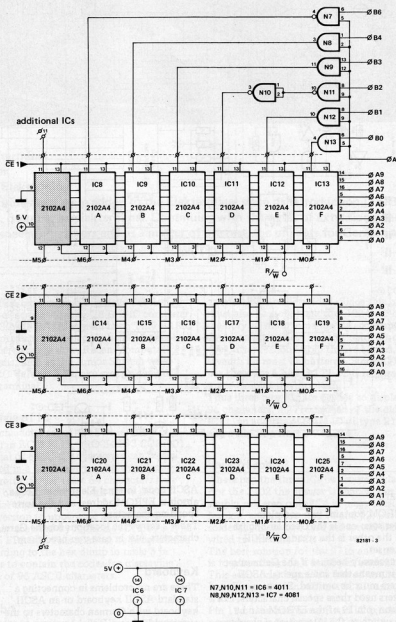
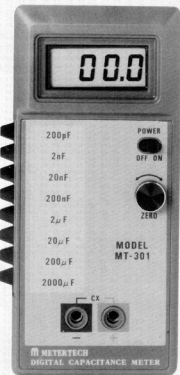

Figure 3. The circuit of the page extension with RAMs for the seventh bit.

LCD digital capacitance meter

The Metertech Model MT 301 is a low cost hand held digital capacitance meter. Battery operated with a bold 0.5" 3 1/2 digit liquid crystal display permitting a wide measurement range from 0.1 pF to 2000 µF across 8 ranges. Push button controls allow fast and easy operation whilst small size, robust construction and long battery life make the MT 301 truly port-



(2522 M)

Centemp Instrument Co.,
62, Curtis Road,
Hounslow,
Middlesex.
Telephone: 01.894.2723.

Microscribe

Terminal Technology, of Newport, Gwent, has launched what is probably the lowest cost and smallest general purpose computer terminal available on the market. Developed and manufactured in the UK, the Microscribe terminal is designed primarily as a desktop information retrieval tool. It can be used with any host computer, peripheral or network utilising the industry standard RS 232C serial interface at speeds up to 9600 Baud whilst supporting XON - XOFF protocol.

Weighing 500 gms and measuring only 190 x 140 x 26 mm, the Microscribe has an ergonomically designed full QWERTY keyboard with a single line alphanumeric LCD display of 16, 32 or 40 characters.

The 8.7 mm high characters are formed from a 5 x 11 dot matrix to give upper and lower case with true descenders. Special graphics with an underline cursor are standard features.

The basic onboard storage capability of 160 characters can easily be expanded to 32,000 by the simple population of internal RAM. A memory protect feature keeps all data stored in RAM intact for 1,000 hours even when the rechargeable batteries are fully discharged. A cassette port allows for the transfer of unlimited amounts of data to and from ordinary cassettes or indication mini-cassettes.

The terminal is microprocessor based, with an elegant software routine that enables a dual operating mode to be selected via the keyboard. These modes are application oriented and enable the terminal to be used in either 'engineering' or 'executive' type environments. The engineering mode allows the user to capture and view all 128 ASCII characters, including control codes, whilst in the executive mode the terminal functions as a standard VDU.

Both NMOS and true CMOS versions are available to offer the user low cost or portability, with a battery operated version giving typically three to four weeks use between charges. A fully automatic contrast control enables high legibility and wide viewing angles to be maintained despite variations in voltage levels.

The software controlled keyboard uses conductive elastomeric technology and features full travel switches with excellent tactile response and selectable audio feedback.

An unusual feature of the terminal is the

interactive set up procedure where the display prompts the user to set up the terminal's communication and operational parameters, and then accepts and retains the redefinition via keyboard commands.

The basic family of terminals will be followed in the very near future with an intelligent version containing a resident high level language, transforming the terminal into a powerful, portable computer, and a version dedicated to word processing.

Terminal Technology,
Clarence House,
Gwent, Newport,
Newport, Gwent NP7 7AA.
Telephone 0633.214128/9.

(2515 M)

Mini Buzzers

Suitable for fire alarm, gas and fire detector, measuring automatic controlling devices, radio communication and numerous consumer product applications, the Murata piezo electric buzzer features high sound pressure with low power level, clarity of sound, small size and, light weight, high reliability and no noise due to the absence of contacts plus low cost. A full technical manual giving comprehensive information on the Piezo Electric Buzzer and its various applications and benefits is available from HB Electronics.

HB Electronics,
Lever Street,
Bolton BL3 6BJ.
Telephone: 0204.386361.

(2518 M)

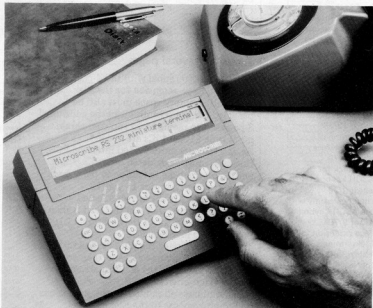

NEW

AVAILABLE NOW

Two**33
electronic games**

A selection of circuits which give as much enjoyment in building them as actually playing the games. The circuits are fascinating although the electronics involved are not complex and therefore anyone with a good soldering iron will find this book satisfying. These are electronic games that do not need a TV screen, and as a result can be played just about anywhere.

Please use the Order Card in this issue

elektor

**Elektor publishers Ltd.
Elektor house 10 Longport
Canterbury CT1 2BR**

new books from elektor



301 circuits

301 circuits

The book follows the theme, and is a continuation of our popular and very successful 300 circuits publication. It is composed of 301 assorted circuits ranging from the simple to the more complex designs described and explained in straightforward language. An ideal basis for constructional projects and a comprehensive source of ideas for anyone interested in electronics. In a nutshell something to please everybody.

Elektor
Publishers Ltd

Please use the Order Card in this issue





elektor book service

FORMANT

Complete constructional details of the Elektor Formant Synthesiser — comes with a FREE cassette of sounds that the Formant is capable of producing together with advice on how to achieve them.
 Price — UK £5.25 Overseas £5.50

SC/COMPUTER (1)

Describes how to build and operate your own microprocessor system — the first book of a series — further books will show how the system may be extended to meet various requirements.
 Price — UK £4.45 Overseas £4.70

SC/COMPUTER (2)

The second book in series. An updated version of the monitor program (Elbug II) is introduced together with a number of expansion possibilities. By adding the Elekterminal to the system described in Book 1 the microcomputer becomes even more versatile.
 Price — UK £4.75 Overseas £5.00

BOOK 75

A selection of some of the most interesting and popular construction projects that were originally published in Elektor issue 1 to 8.
 Price — UK £4.25 Overseas £4.50

TV GAMES COMPUTER

This book, provides a different — and, in many ways, easier — approach to microprocessors. The TV games computer is dedicated to one specific task, as the name suggests. This provides an almost unique opportunity to have fun while learning!
 Price — UK £5.50 Overseas £5.75

JUNIOR COMPUTER BOOK 1

For anyone wishing to become familiar with (micro)computers, this book gives the opportunity to build and program a personal computer at a very reasonable cost.
 Price — UK £5.00 Overseas £5.25

JUNIOR COMPUTER BOOK 2

Follows in a logical continuation of Book 1, and contains a detailed appraisal of the software. Three major programming tools, the monitor, an assembler and an editor, are discussed together with practical proposals for input and peripherals.
 Price — UK £5.25 Overseas £5.50

JUNIOR COMPUTER BOOK 3

The next, transforming the basic, single-board Junior Computer into a complete personal computer system.
 Price — UK £5.25 Overseas £5.50

BOOK 4 £5.25/£5.50

300 CIRCUITS

For the home constructor — 300 projects ranging from the basic to the very sophisticated.
 Price — UK £4.25 Overseas £4.50

DIGIBOOK

Provides a simple step-by-step introduction to the basic theory and application of digital electronics and gives clear explanations of the fundamentals of digital circuitry, backed up by experiments designed to reinforce this newly acquired knowledge. Supplied with an experimenter's PCB.
 Price — UK £5.50 Overseas £5.75

When ordering please use the Elektor Reader's Order Card in this issue (the above prices include p. & p.)

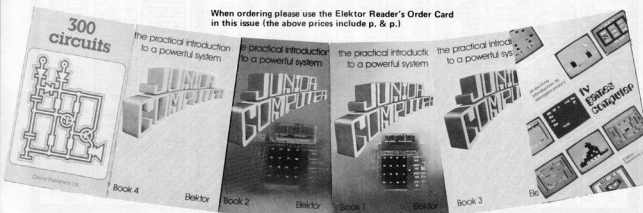



THE NEW MAPLIN CATALOGUE FOR 1983

BRINGS YOU RIGHT UP- TO-DATE IN ELECTRONICS & COMPUTING

Nearly 400 pages of all the most useful components and a whole big new section devoted to home computers and personal software. As always the catalogue keeps you up-to-date with the latest technology — even our ordinary miniature resistors are now superb quality 1% tolerance metal film, yet they're still only 2p each. As well as our usual quality products at low prices, now we're offering quantity discounts too. So pick up a copy of our catalogue now — it's the biggest *and* the best!

ON SALE IN ALL
BRANCHES OF WHSMITH
FROM 18th NOVEMBER 1982
PRICE £1.25

Send now for an application form — then buy it with MAPCARD. MAPCARD gives you real spending power — up to 24 times your monthly payments, instantly.



Post this coupon now for your copy of our 1983 catalogue, price £1.25 + 25p p&p. If you live outside the UK send £1.90 or 10 International Reply Coupons. I enclose £1.50.

Name

Address

.....

.....

E 1/83

MAPLIN

ELECTRONIC SUPPLIES LTD

P.O. Box 3, Rayleigh, Essex SS6 8LR.
Telephone: Southend (0702) 552911/554155

Shops at:
159-161 King Street, Hammersmith, London W6 Tel: (01) 748 0926
Lynton Square, Perry Barr, Birmingham. Telephone: (021) 356 7292
284 London Road, Westcliff-on-Sea, Essex. Tel: (0702) 554000
All shops closed Mondays