

elektor

up-to-date electronics for lab and leisure

82

February 1982

65p.

(R 85p. (incl. VAT))

**universal
nicad
charger**

**strobe light control
dark-room thermostat
10W/70cm amplifier
tolerance indicator**

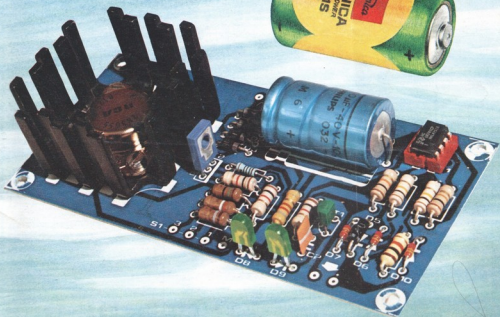

Sumner King

selektor	2-13
food for thought	2-15
10 W/70 cm amplifier	2-16
J. Oudelaar, PA&JOU	
This particular circuit is an extension to the 70cm transverter described recently and boosts its power output up to 10W on both SSB and FM bands. It is temperature-stabilised and is free from oscillation problems.	
teletext power supply	2-21
This particular supply can not only be used to power the decoder, but will also serve other low power applications requiring voltages of +60 V, +5 V and +12 V.	
simulated track extender	2-22
This circuit helps to emulate journeys from London to Edinburgh (or even from Paris to Peking) and is essential if your model railway track is only six feet long.	
dual ADSR and LFO/NOISE modules	2-24
The two modules described here complete the NEW Elektor synthesiser. The dual ADSR module is constructed around two (CEM 3310) envelope generators. The LFO module is combined with a straightforward NOISE generator.	
universal NiCad charger	2-30
The NiCad charger described in this article is able to charge all of the smaller series of cells. The idea being: all batteries in the home can now be replaced by NiCads, using only one charger!	
applikator	2-33
An overview of the Zilog Z 8 family.	
electronics in focus — the photo's	2-36
The first twenty-eight prize-winning entries to our competition — in colour!	
CX and DNR	2-41
The latest in noise reduction systems.	
strobe light control	2-46
The circuit described in this article is neither sophisticated nor complicated, but safe and capable of providing many strobe light patterns.	
tolerance indicator	2-50
H.P. Baumann	
This useful circuit helps to match resistors by comparing their values and indicating any difference between them. It enables tolerances as low as 0.25% to be calculated with accuracy.	
talking board interface	2-52
Using this interface, the data corresponding to one of the words uttered by the talking board can be stored in the microprocessor memory. The speech information can then be applied for other purposes and even modified, if necessary.	
dark-room thermostat	2-58
The circuit described in this article controls the bath temperature — a critical point in photography.	
missing link	2-61
market	2-61
advertisers index	2-74

contents

CONTENTS

EDITOR:

P. Holmes

UK EDITORIAL STAFF

T. Day E. Rogans

P. Williams

TECHNICAL EDITORIAL STAFF

J. Barendrecht

G.H.K. Dam

E. Krempelsauer

G. Nachbar

A. Nachtmann

K.S.M. Walraven



Sumit Singh



Step-by-step fully illustrated assembly and fitting instructions are included together with circuit descriptions. Highest quality components are used throughout.

Sparkrite

BRANDLEADING ELECTRONICS

NOW AVAILABLE IN KIT FORM

SX1000 Electronic Ignition

- Inductive Discharge
- Extended coil energy storage circuit
- Contact breaker driven
- Three position changeover switch
- Over 65 components to assemble
- Patented clip-to-coil fitting
- Fits all 12v neg. earth vehicles

SX2000 Electronic Ignition

- The brandleading system on the market today
- Unique Reactive Discharge
- Combined Inductive and Capacitive Discharge
- Contact breaker driven
- Three position changeover switch
- Over 130 components to assemble
- Patented clip-to-coil fitting
- Fits all 12v neg. earth vehicles

MAGIDICE Electronic Dice

- Not an auto item but great fun for the family
- Total random selection
- Triggered by waving of hand over dice
- Bleeps and flashes during a 4 second tumble sequence
- Throw displayed for 10 seconds
- Auto display of last throw 1 second in 5
- Muting and Off switch on base
- Hours of continuous use from PP7 battery
- Over 100 components to assemble
- Supplied in superb presentation gift box

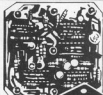

TX2002 Electronic Ignition

- The ultimate system ● Switchable contactless ● Three position switch with Auxiliary back-up inductive circuit
- Reactive Discharge. Combined capacitive and inductive ● Extended coil energy storage circuit ● Magnetic contactless distributor triggerhead ● Distributor triggerhead adaptors included
- Can also be triggered by existing contact breakers
- Die cast waterproof case with clip-to-coil fitting ● Fits majority of 4 and 6 cylinder 12v neg. earth vehicles
- Over 150 components to assemble

VOYAGER Car Drive Computer

- A most sophisticated accessory ● Utilises a single chip mask programmed microprocessor incorporating a unique programme designed by EDA Sparkrite Ltd ● Affords 12 functions centred on Fuel, Speed, Distance and Time ● Visual and Audible alarms warning of Excess Speed, Frost/Ice, Lights-left-on ● Facility to operate LOG and TRIP functions independently or synchronously
- Large 10mm high 400ft-L fluorescent display with auto intensity ● Unique speed and Fuel transducers giving a programmed accuracy of \pm or -1% ● Large LOG & TRIP memories, 2,000 miles, 180 gallons, 100 hours ● Full Imperial and Metric calibrations ● Over 300 components to assemble. A real challenge for the electronics enthusiast!

AT-80 Electronic Car Security System

- Arms doors, boot, bonnet and has security loop to protect fog/sport lamps, radio/tape, CB equipment
- Programmable personal code entry system
- Armed and disarmed from outside vehicle using a special magnetic key fob against a windsensor pad adhered to the inside of the screen ● Fits all 12V neg earth vehicles
- Over 250 components to assemble

All EDA SPARKRITE products and designs are fully covered by one or more World Patents.

EDA SPARKRITE LIMITED 82 Bath Street, Walsall, West Midlands, WS1 3DE England. Tel: (0922) 614791

	SELF ASSEMBLY KIT	READY BUILT UNITS
SX 1000	£12.75	£27.95
SX 2000	£19.95	£43.75
TX 2002	£29.95	£62.95
AT. 80	£24.95	£49.75
VOYAGER	£49.95	£84.75
MAGIDICE	£12.95	£19.95

PRICES INC. VAT. POSTAGE & PACKING

NAME _____
 ADDRESS _____

 I ENCLOSE CHEQUE(S)/POSTAL ORDERS FOR

£282

£ _____ KIT REF _____

CHEQUE NO. _____
 24 hr. Answerphone
 PHONE YOUR ORDER WITH ACCESS/BARCLAYCARD
 SEND ONLY SAE IF BROCHURE IS REQUIRED
 Allow 28 days for delivery

BRANDLEADING BRITISH ELECTRONICS

CUT OUT THE COUPON NOW!

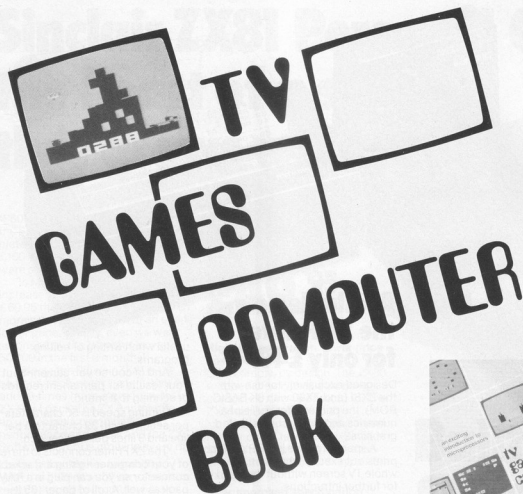

**TV
GAMES
COMPUTER
BOOK**



**an exciting
introduction to
microprocessors**

The first acquaintance with microprocessors can be rather frightening. You are not only confronted with a large and complex circuit, but also with a new language: 'bytes', 'CPU', 'RAM', 'peripherals' and so on. Worse still, the finished article is a miniature computer and so you have to think up some sufficiently challenging things for it to do! This book provides a different — and, in many ways, easier — approach.

The TV games computer is dedicated to one specific task: putting an interesting picture on a TV screen, and modifying it as required in the course of a game. Right from the outset, therefore, we know what the system is intended to do. Having built the unit, 'programs' can be run in from a tape: adventure games, brain teasers, invasion from outer space, car racing, jackpot and so on. This, in itself, makes it interesting to build and use the TV games computer.

There is more, however. When the urge to develop your own games becomes irresistible, this will prove surprisingly easy! This book describes all the component parts of the system, in progressively greater detail. It also contains hints on how to write programs, with several 'general-purpose routines' that can be included in games as required. This information, combined with 'hands-on experience' on the actual unit, will provide a relatively painless introduction into the fascinating world of microprocessors!

£ 5.00 — Overseas £ 5.25
ISBN 0-905705-08-4

selektorsselektorsselektorsselek

TV from outer space

European TV satellites have been in the news a great deal in recent months. This sudden enthusiasm may seem a little odd at first, considering that Europe has not launched a single satellite for television purposes yet. What with the vast networks in the United States, Canada and Japan, which have been operating at a profit for quite some time now, it is understandable that people in Europe are looking forward to the system's introduction on the 'old' continent.

But what really set tongues wagging was the news that the OTS (Orbital Test Satellite), a communication satellite that is already in orbit above Europe, is going to broadcast TV programmes starting in 1982.

Before discussing the proposed venture, it might be useful to find out how TV satellites came into being. TV satellites are communication satellites that transmit programmes directly to cable operators or private TV owners. Communication satellites have made terrific progress since the sixties when they

were first discovered to be an ideal means of linking up two distant locations. They enabled long-distance telephone, telex and data communications to take place without the need for expensive cables, or point-to-point ground stations.

Initially, the satellite transmitters provided relatively little power, so that enormous aerials had to be installed. Fortunately, the great advances in chip technology resulted in much more powerful transmitters and a series of experiments satellites were designed with a wide range of possibilities.

To start with, satellites were used for transmitting live television broadcasts from one point to another on special occasions, such as the American presidential elections or the Olympic Games. Once transmissions improved in quality and smaller aerials could be used, it seemed a good idea to literally broadcast all TV programmes, in other words make sure as many homes as possible would be able to receive them. This was obviously a very attractive proposition in large countries, where the conventional long-distance communication channels are very costly. People in the United States jumped at the idea and cable operators seized the opportunity by installing central aerial systems in towns and villages all over the country. Broadcasting companies can now beam their programmes from a specific

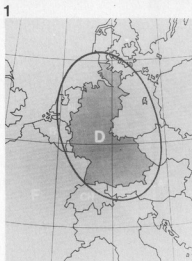

Figure 1. The German TV satellite spill-over range, as defined by the WARC in 1977.

point to a satellite, which then transmits them to millions of viewers. Using an aerial with a diameter of 4.5 metres, cable operators can pick up the signal and 'sell' it to their subscribers. Many Holiday Inn hotels, for instance, have such aerials supplying TV connections in each room. The vogue has also caught on in Canada and Japan.

Meanwhile, Europe is trying very hard to keep abreast with the new developments. The European Space Agency (ESA) which is responsible for the majority of the continent's current space projects and of which many countries are members, has launched fourteen satellites since 1968. The first satellites had the task of carrying out measurements in space and observing the earth (satellite weather charts, etc.). Research on communication satellites as such began in 1971. First of all it was important to draft the main parameters a European satellite should meet. The CEPT (a central European post-office association) and the European Broadcasting Organisation (EBU) made a substantial contribution to the investigation. For one thing, the EBU was eager to improve the Eurovision net-

work and allow TV programmes to be exchanged on a large scale.

The result was OTS (Orbital Test Satellite) which was launched in 1978 to see whether a communication satellite has a sufficient lifespan and adequate power for TV broadcasting purposes. The OTS provides 3000 telephone lines and two point-to-point TV connections. The satellite was destined to pave the way for ECS, the European Communication Satellite, which is due to be launched in 1982. The OTS experiment was completed towards the beginning of 1981 and not only were the results obtained excellent, but the satellite is likely to last for another two years at least. This is much longer than its designers had anticipated.

Five ECS satellites are to go into orbit between 1982 and 1992. These will provide international telephone 'lines', and the organisation also has plans for exchanging TV programmes, establishing links with oil rigs and data communication channels, to connect two large computer networks, for instance.

In 1980, Germany and France, both ESA members, decided to develop a

satellite of their own. This will be the TDF-1 for France and the TV-SAT-1 for Germany. The two countries plan to launch their test satellite in 1984. On the basis of the results, 'real' satellites will go into operation in 1986. The Franco-German satellite will include a 260 W transmitter. This means that a parabola aerial, 90 cm in diameter, will be able to receive an adequate signal, provided it is within the transmission range. Consequently, once aerials drop in price, as estimated, private TV owners outside Germany and France will be able to receive the satellite signal as well.

For obvious reasons, the transmission range of a satellite is almost impossible to delimit with any degree of accuracy. Nevertheless, several international agreements were made at the Geneva World Administration Radio Conference in 1977. One of the main objectives of this conference was to define the broadcasting range for satellites. The 11.7...12.5 GHz frequency range was divided into 40 channels, each country (including Andorra and Luxembourg) being allocated at least five.

The very high 12 GHz wave band clearly offers considerable advantages. In the first place, it provides plenty of channels for every country. Secondly, ultra short waves can be bundled fairly easily, so that, for example, a Belgian TV broadcast can be restricted to a certain area. All the same, there is no way in which a transmission can be prevented from 'crossing a national border'. All the conference could do, therefore, was to give a rough definition of the transmission range for every country. The resulting 'spill-over' range is shown in figure 1, where the West German satellite range covers most of East Germany and the Netherlands.

The UK, Italy, the Netherlands and a number of other countries have set up a team to produce the L-SAT (Large SATellite) under the auspices of ESA. The satellite is due to be launched in 1984. As its name suggests, the L-SAT will be a large satellite, capable of providing telephone and data communications as well as TV and radio broadcasts. The UK has promised to come up with a third of the total costs, about one hundred million pounds.

RTL in Luxembourg (famous for its 'Radio Luxembourg') is also interested in having its own satellite and so are several Scandinavian countries. From 1986, in other words, areas in the UK will be able to receive broadcasts from all over Europe. Readers might think this is still a long way off and at least plenty of time to get ready to welcome or repel, as the case may be, the impending invasion of foreign commercials, but events have already taken an unexpected turn.

As mentioned earlier, the OTS experiment ended last year with the satellite being fully operational for another two years. Engineers at ESA felt it would be

2

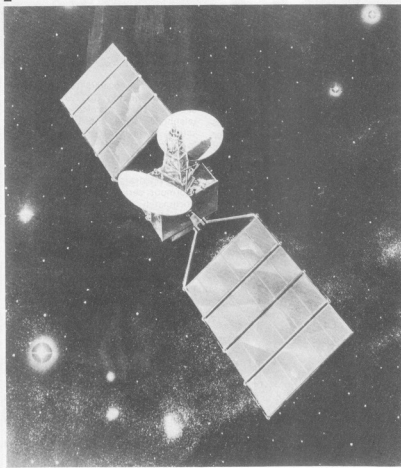

Figure 2. The TV-SAT, the German broadcasting satellite, is due to be launched in 1984.

3



Figure 3. A mobile satellite ground station.

a waste not to make any further use of the satellite and requested Eutelsat (a European telecommunications association with a vested interest in satellites and trustee of the OTS) to grant the satellite a two-year assignment.

During the experimental period, France had used the satellite to broadcast a TV programme to Algeria. The transmission provided a first-class picture and could be received throughout the continent, since the OTS was originally designed to be a communication satellite rather than a TV satellite. Not surprisingly, the French members of Eutelsat were eager to carry on broadcasting to Algeria for a few more years.

Last year, the GPO asked permission to use OTS to establish a point-to-point link between London and Malta. As soon as Eutelsat had agreed to this, the GPO rented the OTS channel to Satellite TV, a British commercial television company. This was totally unexpected and a source of irritation to the other European countries, since OTS was never meant for that purpose. However, it was too late to do anything about it and Satellite TV soon won advertising deals from quite a few multinationals. A number of banks have generously backed the project with ten million pounds' worth of funds. If everything goes as planned, Satellite TV will commence broadcasting in February (3 hours per evening to start with).

Thus, in spite of the Geneva WARC conference, the matter has got somewhat out of hand. Officially, Satellite TV is supposed to transmit on a channel reserved for a point-to-point connection to Malta, but due to the technical performance of the OTS the programmes will be received all over Europe! For

this reason, Eutelsat has ordered the GPO to transmit in code, so that any countries wishing to intercept the broadcasts may do so. A number of countries, however, such as Norway, Austria and Finland, are willing to receive the programmes. Their GPO equivalents will therefore ask Eutelsat to provide cable operators and private TV owners with a decoder and Eutelsat seems unlikely to refuse.

The situation in the UK with regard to satellite TV is far from clear. At the moment, cable operators are forbidden to transmit programmes that include commercials. It is hoped that the Home Office will soon decide what course to take.

Contrary to most people's expectations, the era of satellites is upon us, whether we like it or not. Still, it will take a few years before the man in the street is confronted with 40 channels to choose from every night. M

food for thought

"Europeans think that civilization started in Europe and will end with Europe - or with Western civilization, at any rate. Admittedly, 80% of all computers are in the so-called civilized world. Admittedly, all the radios in Asia 80% are in Japan. We're still building up our industry, and you're well into a post-industrial era. A huge gap!"

"We still have illiteracy to combat. That can be dealt with. The knowledge that we need for our culture can become wide-spread within a few years. But you, living in your computer world, are much worse off! You know everything required for our (in your eyes) backward civilization. But you know nothing at all about your own world! How many of you know anything about computers? How many of you know anything about the new communications media? After all, those are cornerstones of your society. Your knowledge is irrelevant: you know nothing about the important things in your world. Illiteracy in the computer and high-technology world is almost universal!" Wow! That sort of stuff makes you think! The above is not a literal quote, but it is the gist of a speech given by Mr. Madhi Elmandjira of Morocco at the recent International Film and Press Festival in Strassburg. Are we really 'worse than illiterate'? Maybe we are, in more ways than we would like to admit. What does the average Westerner know about the capabilities (or otherwise!) of computers? Or about satellite TV or Teletext?

The same speaker in Strassburg went on to say that "the whole Western world has gone mad . . . There is a yawning gap between the technological possibilities and the capabilities to use them. Television could have been a revolution, but it has turned out to be little more than a radio with pictures. . . You only think in terms of production, without considering the practical use."

Ouch! That hurts. We always thought that we were very practical. After all, that pushbutton telephone shaves several seconds off the time I need to get the 'engaged' tone. . .

OK, so we don't know how some of these modern gadgets work, but we'll continue to use them until they break down. Better still: we'll build our own modern gadgets, before they appear on the market. That's one of the advantages of being 'in electronics'! Meanwhile, Mr. Elmandjira's comments are certainly 'food for thought!' M

selektor
2010

10W/70 cm amplifier

for long-distance transmission

This particular circuit is an extension to the 70 cm transverter described in last year's June and October issues and boosts its power output up to 10 W. Under favourable conditions, the amplifier enables distances of thousands of miles to be bridged on the 70 cm band. The set provides enough power to carry out intercontinental communications using amateur satellites such as OSCAR 8, for instance.

Since the amplifier is linear (it is set for class AB operation, so it draws some quiescent current) it will boost both SSB and FM signals.

The circuit is temperature-stabilised and is free from oscillation problems. This means it is straightforward to construct; an ideal supplement for the transverter.

J. Oudelaar, PA0JOU

Although the circuit was originally intended for 28 V operation, only a few component values need to be changed for a 12 V version. Both sets of values are shown in figure 1: the amplifier circuit diagram.

The 28 V version is equipped with a BLX 92A (T1) in the driver and a BLX 93A (T2) in the output stage. At an output of 10 W the amplifier will consume about 850 mA. The 28 V version has an advantage in that it has a higher gain than the 12 V version. The circuit boosts an input signal of 50 mW to an output of 10 W, an increase of 23 dB. In practice, however, the exact amplification factor will depend on the transistors used, as these have a fairly wide tolerance range.

The 12 V ... 14 V version will appeal to mobile amateur radio enthusiasts as it will enable the 70 cm transverter to be used in the car. Although 12 V transistors are not usually capable of providing as much gain as 28 V types, the difference between the two Elektor prototypes was found to be negligible: 22 dB in the 12 V version as opposed to 23 dB in the 28 V set. Again, however, variations in transistor tolerances will have to be taken into account. The 'worst case' may lead to an output of only 5 W. By boosting the drive unit, the 12 V version can easily be made to achieve 10 W. Its total current consumption at 12 V is then about 2 A.

An in-detail view of the circuit

Let's take a closer look at the circuit diagram in figure 1. The input signal (from the transverter) is fed to the base of T1 by way of an impedance converter network around C1, C2 and L1. The base of T1 is biased with the aid of

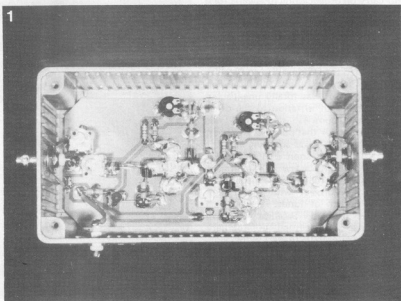

Photo 1. The amplifier is housed in a metal box which also acts as a heat sink.

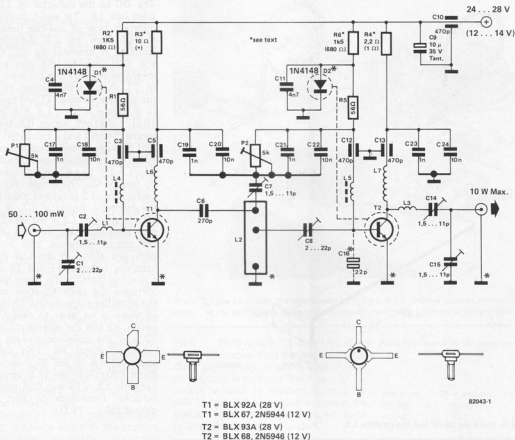

Figure 1. The circuit diagram of the two-stage amplifier, capable of producing 10 W on the 70 cm band.

the inductor choke L4. The choke makes sure the UHF voltage fed to the base does not reach the adjustment network.

The quiescent current through T1 (the collector current) should be about 20 mA in the 28 V circuit and about 35 mA in its 12 V counterpart.

The conducting diode D1 is under a voltage of about 0.7 V. The voltage is fed to the base of T1 and P1 by way of R1. Since the base/emitter voltage of T1 is slightly below 0.7 V, very little current will pass through the base emitter junction of T1. By setting P1 at a higher resistance level, less current will be allowed to flow through the potentiometer, so that much more will be available for the base of T1. The opposite is of course also true, in other words, P1 can be used to vary the base current of T1 and therefore the collector current too.

Amplifier circuits suffer from a temperature stabilisation problem. Often an emitter resistor is included, but this usually reduces the gain in the transistor stage. In this circuit, temperature

stabilisation is achieved by thermally coupling D1 to T1 and this is done by mounting the diode against the transistor. In order to cut down the thermal resistance between the two components a thin layer of thermally conductive paste should be applied as shown in photo 2. When T1 'warms up' its current gain will increase. The temperature of D1 also rises, causing the voltage across it to drop. Thus, the current through T1 will also go down. As a result, the increase in current due to a change in temperature is well compensated for.

Although L4 isolates the biasing network from any UHF, further precaution is necessary. C17 and C18 are connected in parallel to C3 and C4 which ground the UHF. These measures effectively prevent the two-stage amplifier from oscillating. This is an important aspect and has been treated with due consideration in the circuit. Several capacitors are connected in parallel to C3, C5, C12 and C13 to obtain the minimum impedance to earth. Furthermore, the power supply is decoupled by C9 and



Photo 2. The diode and the transistor are thermally coupled using thermally conductive paste. An even better method would be to connect the diode to the heat sink in the direct vicinity of the transistor, but this is very difficult to accomplish in practice.

2

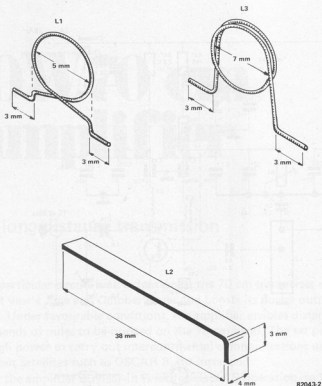

Figure 2. How to make the 'coils' and the stripline L2.

3

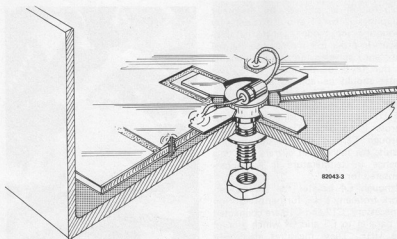

Figure 3. It is important that the transistors are mounted correctly to ensure that they are properly cooled.

C10. Although this involves a few more components, it is worth the extra expense, to prevent any tendency towards instability.

The DC to the collector of T1 is supplied via L6. To avoid oscillation, a different type of coil has been chosen for L6 than for L4. Additional decoupling is provided by C5, R3, C19 and C20. Resistor R3 also acts as a means to measure the collector current of T1. A quiescent current of 20 mA, for instance, through T1 will correspond to a voltage of $U = I \times R = 20 \text{ mA} \times 10 \Omega = 200 \text{ mV}$ across R3. Using this simple method and a voltmeter, the current through T1 can be calibrated.

After the voltage has been amplified by T1, it is fed to a 432 MHz tuned circuit by way of C6. The circuit consists of a Lecher line, L2 (a type of inductor) and the trimming capacitor C7. A tapping off the stripline L2 is fed via C8, to the next transistor stage, T2. This section of the circuit therefore kills two birds with one stone: it provides optimum matching between T1 and T2 and also a selective filter for the 70 cm band.

Virtually the same situation occurs in the amplifier stage around T2 as for T1, so there is no need to repeat all the details. P2 sets the quiescent current of T2 and the collector current can be measured across R4. This should be about 60 mA in the 28 V version and about 100 mA in the 12 V version. The network L3, C14 and C15 adjusts the collector impedance to that of the output (50 ... 75 Ω).

Construction

This is no problem if the printed circuit board in figure 4 is used. All the components are mounted on the board. The coils are positioned in such a manner that they do not require screening.

The board can be housed in an 'Electro-value 5005' diecast case. This aluminium case can also form the heat sink for T1 and T2, as shown in photo 1. Readers are of course welcome to select another type of case, providing the transistors are sufficiently cooled. If the amplifier is housed in the same case as the transverter, a screen must be fitted between the two circuits.

When mounting the components, make sure they are soldered onto the track side (not on the earth plane side). The connections to earth must be soldered to both sides of the board. Don't forget to do this with the earthed connection of L2 (with a short length of wire). The earthed connections for the input and output sockets must also be soldered on both sides.

L1 and L3 are wound, preferably using silver-plated copper wire, in the manner shown in figure 2. L2 is made of a piece of 0.5 mm thick copper or brass sheet (see figure 2). Solder one end of L2 to one side of C7 and one end of C6. The other end of L2 must be connected to

earth as mentioned above.

Capacitor C8 is mounted on top of L2, as indicated in figure 4. Photo 3 clearly shows the construction of this part of the circuit.

The feed-through capacitors C3, C5, C10, C12 and C13 receive a rather unusual treatment, as they are mounted 'flat on their backs' on the board. The connection wires of the other capacitors must be kept as short as possible to avoid self-inductance. Finally, the transistors can be mounted. Care should be taken to ensure that they are positioned correctly. The collector is indicated by a C or a little 'bump' on the package. Sometimes the shape of the collector differs from the other connections. Solder the transistors with considerable care, don't let them get overheated. Instead of soldering all the pins one after another, it is best to wait until the transistor has cooled down before proceeding with the next connection. Such patience could well save you money.

Once all the transistors are well and truly soldered, their body will protrude slightly from underneath the board (see figure 3). The body must either rest on the heat sink or on the bottom of the box. Since the body helps to dissipate heat from the transistor, it should be covered in a layer of thermal conductive paste. The earthed solder connections should not extend too far below the under side of the board, as otherwise the transistor body will be unable to reach the metal surface.

Once the entire circuit has been constructed, it can be fitted in the case (or on the heat sink) by carefully tightening the mounting nuts of the transistors. Be sure to drill the holes for this in the correct positions in the case or heat sink, to avoid having to use physical force when finally fitting the circuit (a most unhealthy situation for the transistors!).

Don't start experimenting until the transistors have cooled down! Now the input and output connectors can be fitted. Their earth connections are linked to the board in two places. Since the wires must be soldered at both sides of the board, this should of course be done before any screws are tightened. The power supply lead can be fed through a hole in the side of the case. An elegant solution is to use a feed-through capacitor with a screw fitting (aluminium is very difficult to solder). The ground connection of the power supply can be directly linked to that of the input or output connector.

Calibration

As mentioned earlier, UHF transmitter transistors are rather expensive, which is why the circuit must be calibrated and operated with due care. To avoid unnecessary mishaps, connect the power supply initially via a resistor to act as a current limiter. By using a car light bulb

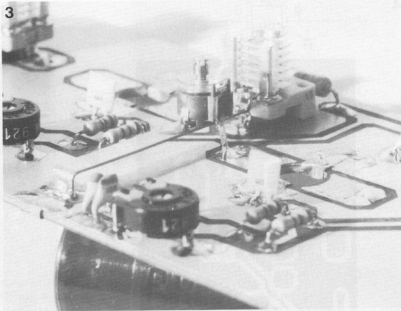

Photo 3. How to mount the components C7, C8 and L2. Several earthed connections are also shown. In the prototypes earthed connections were made underneath the transistors as well.

(500 . . . 1000 mA, 6 . . . 12 V) for this, it will be immediately noticeable if anything goes wrong. A power supply with an adjustable current limit would of course be ideal. In addition, T2 must be able to 'get rid' of its output power, so that an aerial or dummy load will have to be connected to the output.

Calibration is as follows:

- Turn P1 and P2 fully anti-clockwise.
- Connect the power supply (28 V or 12 . . . 14 V) via the light bulb or set a low current maximum.
- Calibrate the quiescent currents of the transistors: Use P1 to adjust the current passing through T1 to 20 mA (200 mV across 10 Ω) for a supply voltage of 28 V, or to 35 mA (350 mV across 10 Ω) for 12 V. Use P2 to adjust the current passing through T2 to 60 mA (132 mV across 2.2 Ω) for 28 V or to 100 mA (100 mV across 1 Ω) for 12 V.
- Either remove the current limiting resistor (the light bulb) or increase the power supply current limit.
- First connect up the transmitter with an output power of about 50 mW.
- Adjust C1 and C2 for a maximum current passing through T1 (measure this across R3). The current level should not, however, exceed 200 mA in the 28 V circuit and 400 mA in the 12 V version. Don't worry, in most cases it is bound to be much less.
- Next adjust C7 and C8 for a maximum current through T2 (measure this across R4). This should not exceed 1 A in the 28 V circuit and 2 A in the 12 V version. Don't let this current continue for too long, as T2 is as yet unable to transmit any power, since the

Parts list for the 70 cm amplifier

Resistors:	28 V version:	12 V version:
R1, R5	56 Ω	56 Ω
R2, R6	1k5	680 Ω
R3	10 Ω	10 Ω
R4	2.2 Ω	1 Ω

Capacitors:

C1, C8 = 2 . . . 22 p foil trimmer
C2, C7, C14, C15 = 1.5 . . . 11 p
C3, C5, C10, C12, C13 = 470 p feed-through (screw fitting)
C4, C11 = 4n7 ceramic
C6 = 270 p ceramic
C9 = 10 μ/35 V tantalum
C16 = 22 p ceramic
(only if Motorola transistors are used)
C17, C19, C21, C23 = 1 n ceramic
C18, C20, C22, C24 = 10 n ceramic

Transistors:	28 V version:	12 V version:
T1	BLX 92A	BLX 67 (Mullard)
	or BLW 90	or BLW 80
		2N5944
T2	BLX 93A	BLX 68 (Mullard)
	or BLW 91	or BLW 81
		2N5946

Coils:

- L1 = turn of 1 mm silver-plated copper wire, 5 mm in diameter
- L2 = strip line (see figure 2) made of brass or copper sheet, 0.5 mm thick
- L3 = 1.5 turns of 1 mm silver-plated copper wire, 7 mm in diameter
- L4, L5 = 2.5 turns of 0.2 mm enamelled copper wire on a ferrite bead
- L6, L7 = 6 turns of 0.5 mm of enamelled copper wire, 4 mm in diameter

Miscellaneous:

- 1 Electrovalue 5005 diecast case

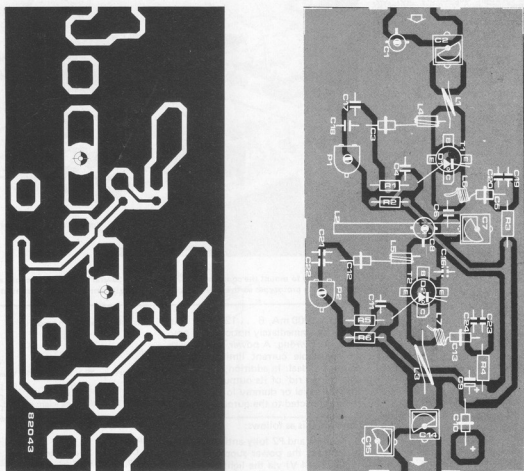

Figure 4. The track pattern and the component overlay for the 10 W/70 cm amplifier printed circuit board. Construction of the board is critical for this type of project and special care must be taken when mounting the components. Particular attention must be paid when making and fitting the stripline L2. It must be remembered that transistors T1 and T2 will not take kindly at all to being overheated during soldering.

output circuit still has to be calibrated.

- C14 and C15 set the output current to a maximum level. The output power can be measured by connecting a standing wave meter between the amplifier and the dummy load (or aerial).
- Finally, all the trimmer capacitors (starting with C1 and ending with C15) should be adjusted for a maximum output. Keep an eye on the collector current of T2 during this process and make sure it does not exceed its maximum value.

One for the road . . .

A good quality coaxial relay is needed

for aerial switching. Readers who don't own one should change the aerial leads by hand. It is not a good idea to use an ordinary relay, as it won't work very well and the loss is likely to be more than 3 dB.

During reception it is advisable to switch off the amplifier voltage. The 28 V version requires an additional contact on the transceiver relay.

If the quiescent current passing through T2 is too low, connect another diode in series with D2. This means of course that the two diodes will have to be thermally coupled to T2.

Last but not least, a word of warning. The transistors used here contain

poisonous beryllium oxide. Provided the transistors are not damaged, they are perfectly safe to work with. As soon as readers notice a crack in the transistor package, avoid touching the beryllium oxide at all costs. Even the fumes are poisonous! Take the offending transistor to the local chemist's or photography store, where it can be disposed of.

✻

teletext power supply

The series on the Teletext decoder failed to describe a suitable power supply. This particular supply can not only be used to power the decoder, but will also serve other low power applications requiring voltages of +60 V, +5 V and +12 V.

Thanks to the modern stabiliser ICs, DC voltages are no longer a problem. Here the 7805 and the 7812 regulate the +5 V and +12 V voltages. The two ICs can endure a maximum output current of 1 A, which is more than enough as far as the complete Teletext decoder is concerned, since this only requires 600 mA at 5 V and 400 mA at 12 V.

Choosing the right transformer is a little more complicated, since the circuit has to provide three different voltages. Things become even more complicated when one of the voltages is 5...10 times higher than the others. The stability of the Teletext tuning voltage (60 V) is of minor importance, as the tuner stabilises it and reduces it to an operational value. Furthermore, the voltage is under a very slight load, so that a straightforward cascade circuit will be sufficient to triple the input voltage. A 15 V transformer secondary will serve the purpose admirably.

The 12 V stabiliser IC requires an input voltage of at least 15 V from the transformer. A lower level than this would produce a considerable ripple across the buffer capacitor. Consequently, the stabiliser would not be able to do its job properly.

A transformer with a centre tap is used here, so that the voltage tripler and the rectification can be combined without running into problems. Two diodes will be sufficient to obtain a rough DC voltage across C3 (see figure 1). This voltage is relatively high for the 5 V stabiliser and for this reason the 10 Ω resistor R1 has been included. The resistor deals with most of the dissipation, which is a great help to the 7805. Nonetheless, both stabilisers have to be adequately cooled.

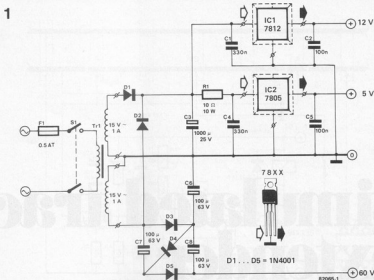

Figure 1. The circuit diagram of the Teletext power supply.

Parts list

Resistors:

R1 = 10 Ω /10 W

Capacitors:

C1, C4 = 330 n

C2, C5 = 100 n

C3 = 1000 μ /25 V

C6, C7, C8 = 100 μ /63 V

Semiconductors:

D1... D5 = 1N4001

IC1 = 7812

IC2 = 7805

Miscellaneous:

Tr1 = transformer 2 x 15 V/1 A

S1 = dpdt mains switch

F1 = 0.5 A fuse

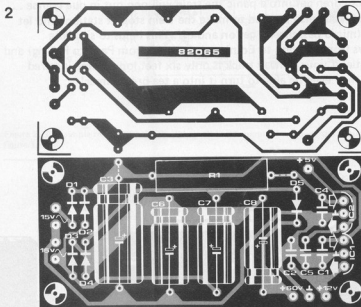

Figure 2. The track pattern and component overlay of the printed circuit board. The voltage regulators are mounted at the edge, with their cooling surfaces facing outward. This will enable a heat sink to be fitted without difficulty.

A word about transformers. Instead of centre tapped winding types, those that have two separate windings can be used. The two windings will have to be connected in series, but the trouble is that it is very difficult to know whether they are connected the right way around.

The total secondary voltage will have to be checked by measuring it with a multimeter (in the AC voltage range). If the connections are correct the value will be about 30 V. If, on the other hand, they are incorrectly connected, the meter reading will be 0 V.

simulated track extender

for model railways

This circuit literally stops the train 'in its tracks' for a certain preset period of time. This is especially effective when it happens in a tunnel, since the train can be made to disappear for a surprisingly long time. Before children get into a panic the train will pop out in due course . . . The circuit can also be used to make the train stop at stations and let the μ p (micro passengers) get on and off. This helps to simulate journeys from London to Edinburgh (or even from Paris to Peking) and is essential if your railway track is only six feet long. Some inspired readers may even be able to turn it into a tea-break timer!

The train leaves and stops automatically after a preset period of time when this circuit, which doesn't require considerable alterations to the track, is connected. If the connection is made at a point in the track where the train can't be seen (for example in a tunnel) it will seem that the train went much further than it actually did. The track seems longer than it really is. Moreover this circuit can also be used to make the train stop as soon as it reaches the station, so that the passengers can get on and off the train, without having to make a run for it.

Simple construction

Although these kind of circuits can be very useful, sometimes the constructor has to face insurmountable problems when operating it from the track. This circuit however is very moderate since it only requires a pulse to activate it. For this purpose ready made contact rails or magnets and reed relays are readily available. However, it looks better and certainly is less noticeable if you insulate two lengths of rail.

As soon as the metal wheels of the locomotive reach the insulated section, a connection is made to the rest of the circuit. The major drawback of this method is the fact that the contact fluctuates. This means that the voltage that arrives at the insulated section when the train reaches it, isn't very constant. The level varies between zero and driving voltage (positive or negative). The 555 timer will be switched on with the first negative edge of the track voltage and its output level (pin 3) will be equal to the supply voltage. LED D3 will light and the relay is pulled on via the transistor. This situation remains unchanged for a period of time, depending on the values of C1, P1 and R5. After this period a new pulse at the input will activate the 555 again.

If the track after the insulated section A is supplied with power via the relay, the train will stop as soon as it enters this area. It will stay there until the

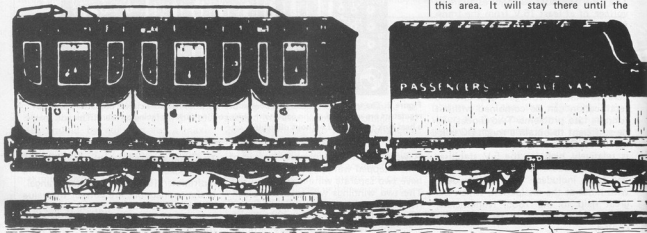

time period is over. A word of warning: make sure that this area is long enough to include the length of the longest locomotive. When moving on the train passes another A section and the 555 is switched on again. However, since area A is very short, a few millimeters are sufficient, the locomotive will just drive on because the next part of the track has the normal track supply connected.

The same holds good for trains coming from the opposite direction, so that this circuit can be used for two way traffic.

Practical details

First some advice that can make it easier for you, if you find yourself in trouble during construction. Instead of the well-known 555 you can also use the newer 7555, which certainly isn't inferior to the 555. Its major advantage is in its low current consumption. Beware that you don't power the circuit with the track supply for the locomotive. A separate supply of 10-15 V is a must. It is recommended that the supply voltage is equal to the coil voltage of the relay. A low current relay is preferred, since the current consumption of the complete circuit depends on it. A Siemens E printed circuit board relay serves the purpose perfectly well, since it can switch up to 8 A, whereas the coil only consumes 36 mA. It is wise not to use a relay having a current consumption of more than 1 A.

In fact, the input of the 555 reacts on the interference caused by the wheels of the locomotive, thus making the 'stay away' circuit suitable for an a.c. track supply (Märklin). The track extender time can be preset between 1 and 10 seconds by P1. If required the time can be changed by altering the value of C1, a larger capacitor extends the period of time.

It is possible that the circuit may be too sensitive, so that the LED lights at random. In that case the value of R1 should be lowered. When a slow moving train doesn't activate the 555, then R1 has to be increased.

The power supply circuit in figure 2 will be quite adequate for the simulated track extender. **M**

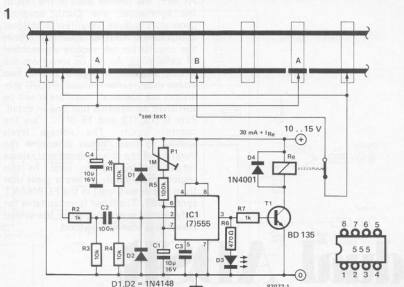

Figure 1. The complete circuit diagram. The insulated A sections in the track should be spaced the length of the longest locomotive apart.

2

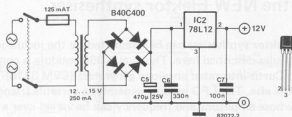
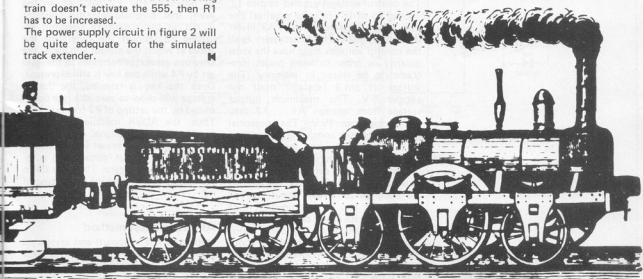

Figure 2. This simple regulated power supply is all that is required to power the circuit of figure 1.



As with the devices used in the rest of the synthesiser, the Curtis envelope generators require very few additional components. Another advantage is that the circuits do not require a great deal of calibration. As can be seen from the circuit diagram in figure 1, the two attack-decay-sustain-release (ADSR) generators are identical, therefore it will be sufficient to describe just one in detail. Pins 9, 12, 13 and 15 of IC1 are the control inputs. The voltage levels applied to these inputs determine the duration of the attack, decay and release times and the sustain level. In this respect the module differs a great deal from the circuit used in the FORMANT synthesiser. The latter is not suitable for polyphonic operation using the stored preset data scanning method.

dual ADSR and LFO/NOISE modules

... for the NEW Elektor synthesiser

The NEW Elektor synthesiser can be completed by the inclusion of the two modules described here. The dual ADSR module is constructed around two Curtis integrated envelope generators (CEM 3310) and very little else. The LFO module generates a versatile triangular waveform whose amplitude and frequency can be varied over a wide range. A straightforward NOISE generator has also been included on the LFO module. Together with the previously published VCF and VCA, the two modules described here are capable of producing a whole range of different sound effects similar to those described in the FORMANT books and articles.

The control voltages applied to pins 12, 13 and 15 of IC1 must be negative! For this reason, opamps A1...A3 invert the input signals. This is necessary as all the control voltages must have the same polarity in order to allow preset 'programs' to be stored in 'memory'. The voltage at pin 9 (sustain) must not exceed 5V. The maximum output voltage from opamps A1...A3 may be as high as 15V. The potential divider networks consisting of resistors R9...R14 reduce the incoming control voltages for the attack, decay and release times to provide the correct sensitivity for the IC inputs. The circuits are designed for a gate input level of between 5V and 15V (although it must be 0V when no key is depressed). When using the FORMANT keyboard, which supplies a gate pulse level of about 15V, the FORMANT interface receiver board can be connected between the gate output of the keyboard and the

ADSR (LFO) gate input. This will then provide a gate pulse level of between 0 and 5V. Control direct from the keyboard (without using the interface receiver) requires no modification to the ADSR circuit, since diode D2 (D2'), prevents any negative voltage from reaching pin 4 of IC1. In this case, however, the FM delay circuit on the LFO board requires a minor modification. A diode (shown dotted in figure 5) must be placed across capacitor C1 in order to protect it against negative voltage levels. It should be noted that a gate input level of 15V will cause C1 to charge more quickly than a 5V level and this should be taken into consideration during the calibration of P1. Sockets should be used for IC3 and IC4 and until these ICs are required, wire links should be installed between pins 1 and 2 and between pins 8 and 9. Consequently, all the wipers of the potentiometers will be connected directly to the circuit. These ICs are not required until the synthesiser is fully extended (details will be published in a future article).

Adjusting the envelope

The two gate inputs are connected together and linked to the gate output pulse of the FORMANT keyboard. When testing the circuit it is advisable to monitor the ADSR (1 and 2) outputs with the aid of an oscilloscope. The timebase frequency of the oscilloscope should be set to approximately 1 Hz. Set the sustain potentiometer (P4) to maximum (wiper towards 15V) and depress any key on the keyboard.

If the wiper of P1 (attack) is turned towards ground (minimum), the output of the envelope generator IC will immediately rise to its maximum level. As this potentiometer is turned up, the time taken for the output of IC1 to reach its maximum level will increase. By releasing the key, the reverse procedure can be carried out with the aid of potentiometer P2 (release). In the event that potentiometer P4 (sustain) is not in the maximum position, adjusting P3 (decay) will determine the speed at which the output voltage of the envelope generator decreases to the level set by P4 while the key is still depressed. Once the key is released, the output voltage will drop to zero at a rate determined by the setting of P2 (release).

Thus, the ADSR module produces a 'typical' envelope signal. If a key is released before the preset sustain level is reached, the output voltage will automatically drop to zero. The time taken for this is determined by the setting of P2.

Alternative test method

Instead of the keyboard and associated gate pulse, a low frequency oscillator (see figure 2) can be used to control the ADSR circuitry. By applying a square-

2

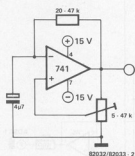

Figure 2. This squarewave oscillator can be used to test the envelope generators.

wave signal (± 15 V) to the gate input of the module, the envelope generator will produce an envelope similar to that shown in figure 3. It is essential that the attack, decay and release times are shorter than the duration of the applied squarewave input signal. (For example, with an input frequency of 20 Hz, the A, D and R times should not be greater than 1/80th of a second.) The various pin connections for the dual ADSR module are given in figure 4.

The LFO

Anyone familiar with the FORMANT circuitry will notice that the circuit of the low frequency oscillator in figure 5 does not possess a sawtooth or squarewave output. Although such waveforms are very handy for producing all sorts of

3

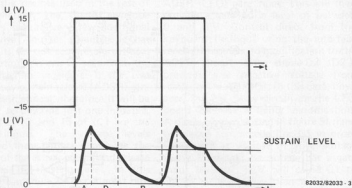

Figure 3. This is what the typical ADSR waveform looks like when the squarewave generator of figure 2 is connected to it.

4

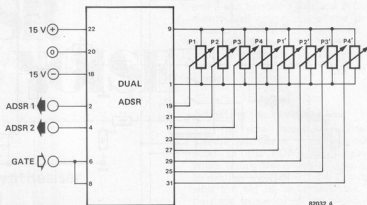

Figure 4. The wiring for the dual ADSR module. The board connection numbers correspond to those given in the component overlay of figure 8.

5

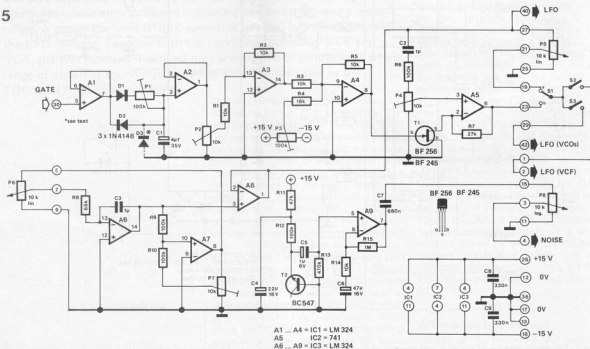

Figure 5. The circuit diagram of the LFO/NOISE module.

sound effects, the main requirement at the moment is to produce good quality music and for this all that is needed is a triangular signal. The frequency and amplitude of the LFO should not be too high, as then excessive VCO frequency shift will cause the original pitch to be distorted beyond recognition. In fact the synthesiser will probably end up sounding somewhat like an American Police siren!

If the frequency of the LFO signal exceeds 16 kHz, mixture products, similar to ring modulator effects, will become audible. The LFO module is also capable of producing the popular delayed and continuous vibrato effects. What happens is that the LFO signal is fed to a VCA which is triggered by the keyboard

gate pulse following a long attack time and a very short release time (100% sustain). The output waveform of the LFO module is shown in figure 6. A key has to be depressed for a relatively long time before any change occurs in the static sound spectrum. The effect is quite impressive and pleasant, but very difficult to describe. It will have to be heard to be fully appreciated!

The LFO and vibrato circuitry does not have to be elucidated at great length. An integrator (A6) with negative feedback applied produces a triangular output signal. The frequency of this signal can be varied over a wide range. The triangle signal is fed to the output of the LFO module via a voltage follower (A8). The vibrato circuit is basically a non-

6

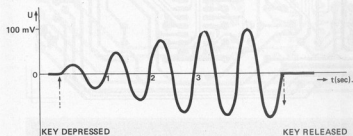

82032/82033 - 6

Figure 6. The waveshape of the output voltage of A5 in figure 5. After a key is depressed, the amplitude of the LFO signal increases gradually. This results in a delayed and gradual vibrato effect.

7

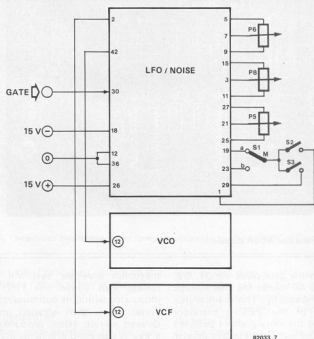

82033 7

Figure 7. The wiring details of the LFO/NOISE module.

Parts list LFO-NOISE

Resistors:

R1, R2, R3, R5, R14 = 10 k
R4 = 18 k
R6, R9, R10, R12 = 100 k
R7 = 27 k
R8 = 68 k
R11 = 47 k
R13 = 470 k
R15 = 1 M
P1, P3 = 100 k preset
P2, P4, P7 = 10 k preset
P5, P6 = 10 k linear
P8 = 10 k logarithmic

Capacitors:

C1 = 4 μ7/35 V
C2, C3 = 1 μ metal foil
C4 = 22 μ/16 V
C5 = 1 μ/6 V
C6 = 47 μ/16 V
C7 = 680 n
C8, C9 = 330 n

Semiconductors:

D1 ... D3 = 1N4148
T1 = BF 256 (BF 245)
T2 = TUN (BC 547)
IC1 (A1, A2, A3, A4) = LM 324
IC2 (A5) = 741
IC3 (A6, A7, A8, A9) = LM 324

Miscellaneous:

S1, S2, S3 = spst switch
21 pin connector

Parts list ADSR

Resistors:

R1, R1', R2, R2', R3, R3',
R6, R6', R7, R7', R8, R8' = 22 k
R4, R4' = 10 k
R5, R5' = 4k7
R9, R9', R10, R10', R11, R11' = 15 k
R12, R12', R13, R13', R14, R14' = 330 Ω
R15, R15' = 820 Ω
R16, R16' = 27 k
R17, R17' = 100 Ω
R18, R18' = 1 k
R20, R21 = 100 k
P1 ... P4, P1' ... P4' = 10 k linear

Capacitors:

C1, C1' = 10 n
C2, C2' = 22 n
C3, C3' = 33 n
C4, C4', C5, C5' = 330 n

Semiconductors:

D1, D1', D2, D2' = 1N4148
IC1, IC1' = CEM 3310
IC2, IC2', IC5 = TL 084
IC3, IC3', IC4, IC4' = 4066
(not required for simple version)

Miscellaneous:

21 pin connector

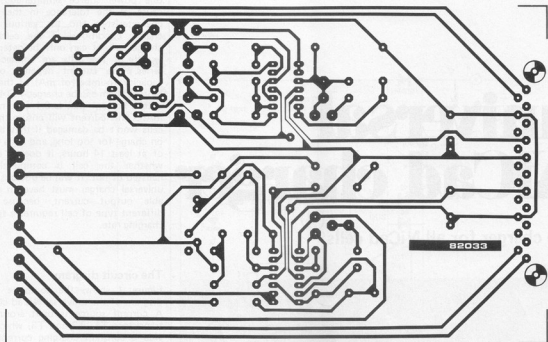

Figure 9. The printed circuit board and component overlay for the LFO/NOISE module.

quarter tone. The output voltage of the VCA should remain as low as possible.

Noise generator

The white noise produced by the base/emitter junction of an NPN transistor (with suitable gain) meets the requirements set for electronic music purposes

(see lower section of figure 5). The noise signal can be fed directly to the audio input of the VCF (near R3 on the VCF/VCA module) by way of potentiometer P8.

If the filter is in the 'tracking' mode, melodies featuring pink noise can be played. The sound of the wind can be imitated by changing the cut-off charac-

teristics of the filter. Figure 7 shows how to connect the LFO/NOISE module to the rest of the synthesiser. Steam engines, percussion effects and pistol shots can all be imitated by using various ADSR curves. ■

universal NiCad charger

one charger for all NiCad cells

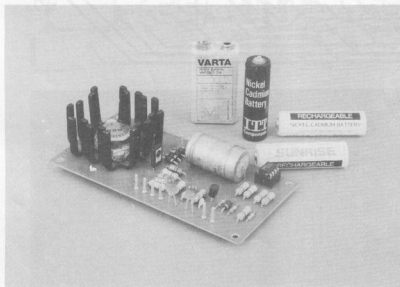

NiCad cells are an economic alternative to batteries, but if you have to buy a special charger for each type of cell, this cheap alternative turns into an expensive one. The solution to this problem is a charger that is able to charge the whole range of cells. As you may have suspected, this article deals with such a device. To prevent any damage to the cells, the charger is also protected in the event of an incorrect connection.

It is not possible to connect NiCad cells in parallel in order to charge them from one power source simultaneously because of the tolerance in the charge characteristics and the various initial charge conditions of the cells. The charge current can only be determined exactly if the cells are connected in series. The current depends on the capacity (number of mAh) of the cells. Most of them can be charged in 14 hours with a current that is $0.1 \times$ number of mAh. This current will ensure that the cells won't be damaged if they are left on charge for too long, and for a charge of at least 14 hours, it doesn't matter whether the cell is completely exhausted or not. It will be obvious that a universal charger must have an adjustable output current, because each different type of cell requires a specific charging rate.

The circuit diagram

Figure 1 shows the complete circuit diagram of the universal NiCad charger. A current source is built around the transistors T1, T2 and T3, which provide a constant charging current. The current source only comes into operation when the NiCad cells are connected the right way round (positive to + and negative to -). It is the task of IC1 to verify the connection by checking the polarity of the voltage at the output terminals. When the cells are connected correctly, pin 2 of IC1 won't be as positive as pin 3. Therefore the output of IC1 becomes positive and supplies a base current to T2, which switches on the current source. The desired level of the current source can be set with the aid of S1. A current of 50 mA, 180 mA and 400 mA can be preset when the values of R6, R7 and R8 are known. Putting S1 in position 1 means that the penlight cells will be charged, position 2 is for C cells and it is the D cells' turn in position 3.

The current source functions very simply. The circuit is a current feedback system. Suppose that S1 is in position 1 and IC1 output is positive. T2 and T3 are now supplied with a base current and start to conduct. The current through these transistors produces a voltage across R6, thus causing T1 to conduct. An increasing current across R6 means that T1 will conduct more thereby reducing the base drive current to transistors T2 and T3. The latter transistors will now conduct less and the original current increase is opposed. A fairly constant current through T3 and the connected NiCad cells is the logical result.

Two LED's that are mounted on the current source show whether and how the NiCad charger is working. IC1 supplies a positive voltage when the cells are connected correctly and DB will light. With an incorrect connection, pin 2 of IC1 will be more positive than

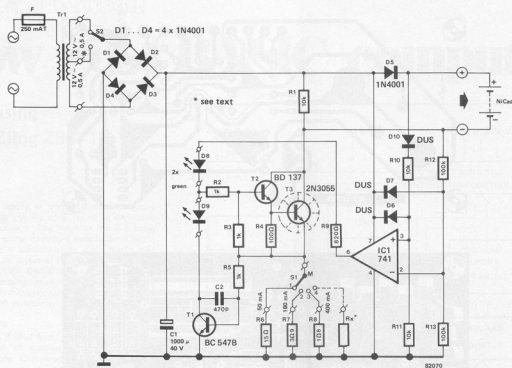





Figure 1. The universal NiCad charger consists of a switchable current source (T1, T2, T3) and a comparator (IC1) that checks the polarity of the cells. Two LED's (D8, D9) indicate whether the supply voltage is sufficient, whether the cells are charged with the correct current and last but not least, whether the cells are connected correctly.

Table 1.

	name and international type indication	IEC. nr. battery	IEC. nr. NiCad cell	Charge current for sintered cells	S1 in position
	penlight AA	R6 (1.5 V)	KR 15/51 (1.2 V)	45 ... 60 mA	1
	baby C	R14 (1.5 V)	KR 27/50 (1.2 V)	165 ... 200 mA	2
	mono D	R20 (1.5 V)	KR 35/62 (1.2 V)	350 ... 400 mA	3
	power-pack PP3	6F22 (9 V)	— (7.5 V) (8.4 V) (9 V)	7 ... 11 mA	4

Parts list

Resistors:

R1, R10, R11 = 10 k
 R2, R3, R5 = 1 k
 R4 = 100 Ω
 R6 = 15 Ω
 R7 = 3.9 Ω
 R8 = 1.8 Ω
 R9 = 820 Ω
 R12, R13 = 100 k

Capacitors:

C1 = 1000 μ/40 V
 C2 = 470 p

Semiconductors:

T1 = BC 547B
 T2 = BD 137
 T3 = 2N3055
 IC1 = 741
 D1 ... D5 = 1N4001
 D6, D7, D10 = DUS
 D8, D9 = LED (green)

Miscellaneous:

Tr1 = transformer 2 x 12 V/0.5 A
 S1 = 3 position switch
 S2 = 2 position switch
 heat sink for T3 (TO-3 housing)

The table illustrates which battery can be replaced by which NiCad cell (with sintered cells). The capacity of the cells differs with each manufacturer.

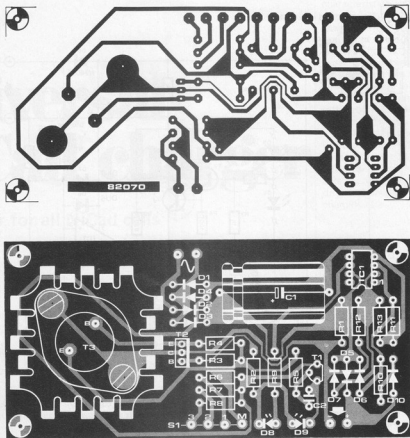

Figure 2. The track pattern and component overlay of the universal NiCad charger. Transistor T3 must be mounted on a heat sink.

pin 3, so that the opamp, which is wired as a comparator, has 0 V output. Now the current source isn't switched on and LED D8 will not light. The same holds good for the case when no cells are connected, since pin 2 will have a higher voltage than pin 3, caused by the voltage drop across D10. The charger will only work when a cell containing at least 1 V is connected.

LED D9 indicates that the current source is functioning as a current source. This may sound a little strange, but an input current produced by IC1 isn't sufficient, there also has to be a voltage level high enough to stabilise the current. This means that the supply must always be higher than the voltage across the NiCad cells. Only then will there be a high enough level for the current feedback T1 to function, causing D9 to light.

Practical points

Figure 2 illustrates the track pattern and

component overlay of the printed circuit board. Except for the transformer, all components can be mounted on the board. A heat sink for T3 is a must, since the transistor will run warm, especially when only a few cells are being charged. It is therefore recommended that a transformer with a centre tap is used, so that a lower supply voltage can be selected by means of S2. This centre tap not only prevents T3 from getting overheated, but it also saves a lot of energy. Diode D9 lights to indicate that there is sufficient supply voltage.

As stated before the penlight cells are charged with a current of 50 mA when S1 is in position 1. C and D type cells can be charged with 180 mA and 400 mA respectively (positions 2 and 3). The value of R6, R7 or R8 must be changed if other charging currents are required. The desired value can be found by dividing 0.7 V by the charging current. For example, for a charging current of 100 mA a resistor value of

$0.7 \text{ V} : 0.1 \text{ A} = 7 \Omega$ is required. Currents up to 1 A are possible, however it must be remembered that T3 will require a larger heat sink. We will not complain or object if you replace S1 by a switch with more than 3 positions.

Resistor Rx in figure 1 is shown in the position for one further current rate if desired.

Charging NiCad cells takes about 14 hours. It is wiser to use sintered cells, because they won't be damaged if this limit is passed. ■

aplikator
COMPUTER

low cost BASIC computer

... using
 the Zilog Z8671

The Z-8 family of microcomputers provides capabilities usually only found in dedicated microprocessors. The heart of the Z-8 Basic microcomputer described here is the Z8671. This chip is based on the Z-80, but it also contains 2K bytes of ROM (pre-programmed with a TINY BASIC interpreter), extensive I/O processing capabilities, 144 bytes of RAM, a full duplex UART and two counter/timers with prescalers.

Hardware

The Zilog Z8601 microcomputer introduces a new level of sophistication to single-chip architecture. Compared to earlier single-chip microcomputers, it offers faster execution; more efficient use of memory; more sophisticated interrupt, input/output and bit-manipulation capabilities; and easier system expansion. Furthermore, the device can be tailored to the needs of the user. The Z8671 is an example: it contains 2K bytes of internal ROM, pre-programmed as a BASIC interpreter and debugger.

In general, the Z8601 architecture is characterised by a flexible I/O scheme, an efficient register and address area structure and a number of ancillary features that are useful in many applications.

Three main address ranges are available: program memory (internal and external), data memory (external) and the register file (internal). The 144 byte random-access register file is composed of 124 general purpose registers, four I/O port registers and 16 control and status registers. To relieve the program from real-time problems such as serial data communication and counting/timing, an asynchronous receiver/transmitter (UART) and two counter/timers are offered on-chip. Hardware support of the UART is minimized because one of the on-chip timers supplies the bit rate.

A complete system

A complete system will consist of three sections: processing, memory and I/O. The processing section is based on a Z8671 microcomputer. As mentioned above, this contains a mask programmed 2K TINY BASIC interpreter and debugger. The memory section can be expanded to 62K of RAM or EPROM. The Z6132 is a 4K Quasi Static RAM which is pin-compatible to the 2732 EPROM. This device behaves like a static RAM, although it actually consists of a dynamic RAM with its own refresh on chip. This has two advantages: high speed and low power consumption. Possible access time ranges from 200 ns (version -3; cycle time is 350 ns) to 350 ns (version -6; cycle time

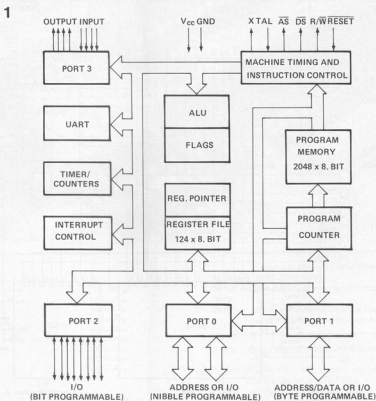

82075 1

Figure 1. Block diagram for the BASIC computer system.

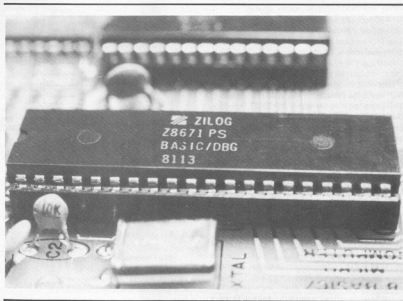

2

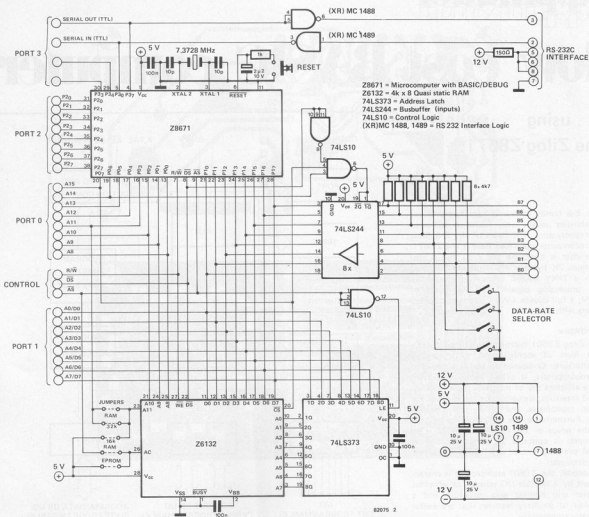
Figure 2. The circuit diagram for a μ P system using the Z8671.

is 450 ns). Power consumption is 250 mW active and 125 mW stand-by.

The I/O section can handle serial and parallel communication. Parallel ports are available directly on the Z8671. One port is used for input purposes while the other is bit programmable as input or output port. External I/O via a bus buffer (74LS244) is possible. The serial port is standard RS 232C interface (MC 1488 and 1489). Serial communications are also possible in TTL levels. Baudrates can be selected from 110 to 9600 baud via DIL switches.

A complete circuit is given in figure 2. The power supply requirements are: +5 V about 250 mA; +12 V 30 mA; -12 V 30 mA. The +12 V and -12 V are used for the RS 232C only. Data and address lines are multiplexed.

Features of the Z8671 MCU

- Complete microcomputer, 2K bytes of ROM, 128 bytes of RAM, 32 I/O lines, up to 62K bytes addressable external memory area for program and data.
- 144 Byte register file, including 124 general purpose registers, four I/O port

3

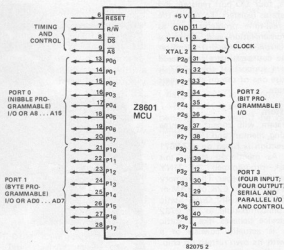
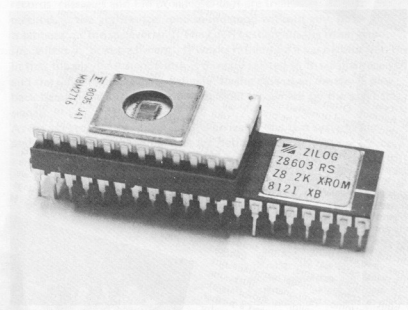
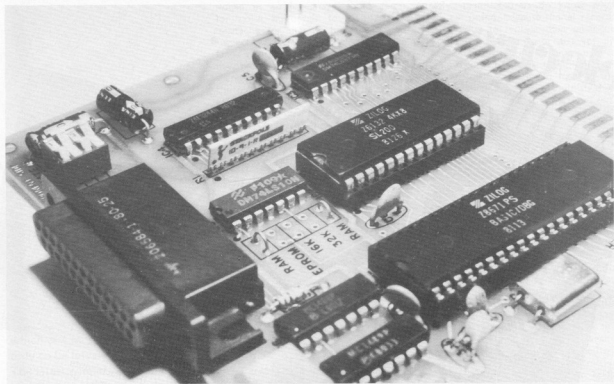

Figure 3. Pin assignment of the Z8601 MCU.



- registers and 16 status and control registers.
- Full duplex UART and two programmable 8-bit counter/timers, each with a 6-bit programmable prescaler.
 - On chip oscillator which accepts crystal or external clock drive.
 - Average instruction execution time of 2.2 μ s, maximum of 4.25 μ s.
 - Register pointer to enable fast instructions to, access any of nine working register groups in 1.5 μ s.
 - Vectored priority interrupts for I/O, counter/timers, and UART.
 - Low Power option which retains the contents of the general purpose registers

- [Z 8675 BASIC/DEBUG with power down option].
- Single +5 V power supply; all pins TTL compatible.

Literature:

- Zilog - Z 6132 4K x 8 Quasi Static RAM product specification (January 1981)
- Z 8 Family of Microcomputers Z 8601, Z 8602, Z 8603 product specification (December 1980)
- Z 8 BASIC/DEBUG Software Reference Manual (March 1980)
- Z 8 Microcomputer Preliminary

- Technical Manual (December 1978)
- 1981 Data Book
- Micro - Z 8 BASIC Computer/Controller
- Mint
- Byte - Build a Z 8 based Control Computer with BASIC July and August 1981.

Z - 8 Bird's eye view of the Z 8 family

- Z 8601 Single Chip Microcomputer with 2K mask programmable ROM.
- Z 8611 Identical to 8601 but with 4K mask programmable ROM.
- Z 8671 Single Chip Microcomputer with 2K ROM pre-programmed with BASIC/DEBUG.
- Z 8675 Same as the 8671 but with so-called power down mode operation (after power has been turned off the contents of the general purpose registers will be saved).
- Z 8681 ROMless version of Z 8601. Carries intelligence to use a port for I/O addressing of external ROMs with the systems monitor. Specifically fit for machine language applications. This one is the cheapest member of the Z-8 family.
- Z 8602, Development Devices. They are identical to 8601 and 8611 respectively, with the following exceptions:
 - The internal ROM has been removed.
 - The ROM address and data lines are buffered and brought out to external pins.
 - Control lines for the extra memory have been added.
- Z 8603 This is a ROMless version of the Z 8601 in a pin-compatible 40-pin package with a 24-pin IC-socket on its back ('piggy back' version).
- Z 8613 The 2732 version of the Z 8603.

electronics in focus...

... the photo's!

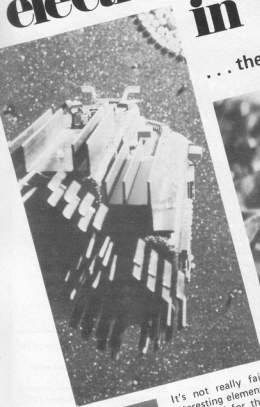

It's not really fair. One of the most interesting elements in any competition is reserved for the judges: they are the only people who get to see *all* entries! Good or bad, they all have something of interest — even if it is sometimes unintentional humour. Often an accidental juxtaposition of several unrelated entries can be 'read' as a short story. The photo of a circuit with the battery connected the wrong way round, say, together with an exploding electrolytic capacitor. For that matter, several entries bear witness to a destructive streak: exploding capacitors, broken valves, 'axed' TV sets, and so on.

On the more constructive side, the entries were even more varied. An IC-plus-LED leaf-eater was one of the simplest; at the other extreme, Mr. W. Lehrke built a complete model aeroplane out of electronic components (just one engine plus propeller is shown here). Several enthusiasts introduced a further element: electronics as a space-age (or even 'science fiction') technology. A beautiful example is the spaceship, entered by Mr. S. Folliot. The 'cooling fins' are very much in evidence! Not surprisingly, resistors were often used as photographic models. The varied colour-codes are very colourful! In fact, one wonders if happy little painters are really responsible for those decorative rings, as suggested by Mr. H.M. de Wijs.

It's unfortunate that the black/white reproduction on this page doesn't do it justice.

For that matter, the same applies to most entries. Mr. H.-J. Brede's cocktail looks much better in colour. He also entered a tin of 'pipe tobacco' (resistors, actually!), but that doesn't come out at all in black/white. However, the next four pages give some idea of the entries — in full colour! We only had room for the first twenty-eight, unfortunately. Even if we restricted ourselves to the most interesting entries, we could fill a book! Lots of not-quite-prize-winners are worth seeing: a painting with solder, an IC creeping up a girl's nose, a CB fanatic in the sauna. LEDs in the flowers, and so on . . . However, as we said at the outset: that's the advantage of judging a competition!

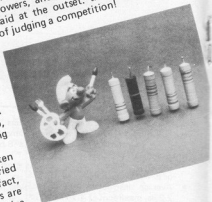

'Down with noise' could well be the slogan at an imaginary audio demo, for noise continues to be a major headache for manufacturers and consumers alike. Take records, for instance. Once digital recording technology and new record materials have come on the scene, just about every possibility using the old analogue system will have been exhausted, unless... Unless we all go digital and buy the Compact Disc (Philips, Sony) or the Mini Disc (Telefunken).

Cassettes, however, do still have room for improvement if the ever-increasing array of 'oxide buttons' on cassette decks is anything to go by. The noise

staked on the 'wrong horse'! Fortunately, manufacturers do know what they are doing, because digital records aren't going to replace their analogue counterparts, at least not just yet. In any case, it is by no means certain that digital records have a better noise factor than analogue records. In fact, as the article 'one-nil for audio' published in Elektor (September 1979) pointed out, digital noise sounds a lot worse than analogue noise, so the same signal-to-signal ratio problem exists here too.

Where noise cannot be filtered out easily, if at all, one remedy is to make it less audible using a noise reduction system. Such systems fall into two main categories.

First of all, there is the 'compansion' recipe. Treat the signal before transmitting it either 'on the air' or on record or cassette and make sure it is treated again afterwards during the playback phase, so that the signal returns to its original state. This involves compressing the audio signal in the transmitting stage to make it more powerful than the noise. Unfortunately, the audio signal risks being totally unacceptable at the receiver end, unless it is treated again. Thus, the best results are obtained by compressing the signal in the transmitter and expanding it in the receiver. Such systems are known as companders and the majority of noise reduction units come under this category. The most famous are, of course, Dolby, dbx, High Com (see Elektor 70 and 71) and now CX.

CX and DNR

the latest in noise reduction

The development of noise reduction systems is rather like a race in which one manufacturer overtakes the others on the road to perfection, only to be left behind by a new rival in the next round...

The latest winners are called CX and DNR and were recently introduced by CBS and National, respectively. CX stands for compatibility: records, cassettes and FM broadcasts that are treated, using this method, at the 'transmitter' end sound good without any 'post-treatment' at the receiver end. The DNR system, on the other hand, specializes in 'post-treatment'. It works rather like a bandwidth 'tap', in that the playback bandwidth is directly related to the signal received and the noise is reduced accordingly. In the case of an extensive playback bandwidth, the noise level is masked (drowned) by the playback signal.

As far as records are concerned, the arrival of the two systems may seem a little late, for digital discs are definitely on the way.

factor during FM broadcasts largely depends on the noise features of the tuner. Nowadays, excellent signal-to-noise ratios of 70...85 dB can be obtained at aerial input levels of roughly 2000 microvolts, but then such quality has its price. (Aerial amplifiers can easily produce 2000 μ V - but also plenty of noise into the bargain!)

The second category includes the DNR system. But before we deal with the noise reduction systems in detail, readers might like to know why all these efforts to improve a century-old sound reproduction system are necessary. Admittedly, CX is as compatible as CBS and the additional electronics it requires is straightforward and inexpensive. The fact remains, analogue, dust-collecting gramophone records are about to be superseded by digital records any minute now. Why then are manufacturers continuing to run this particular race, or are they all wearing blinkers and unable to see the finish line? For if digital records are all they promise to be, an awful lot of money is being

The dynamic noise filter: the bandwidth 'tap'

This method concentrates on filtering the audio signal in the receiver and is universal. Readers may wonder why this kind of system is not used instead of the various 'compansion' devices mentioned earlier, since that would surely solve the compatibility problem once and for all. The trouble is, it does not lead to a real improvement in the signal-to-noise ratio in terms of dB, and the audio signal is in danger of deteriorating as well.

What does a dynamic noise filter involve? Noise is quite a nuisance at frequencies between 1 and 10 kHz. Usually, however, the audio bandwidth above 1...2 kHz is not required, so that a low-pass filter can be used. If no audio signal is reproduced at all, the filter will be set at a minimum turnover frequency to achieve the maximum amount of noise reduction. For signals with frequencies above the minimum turnover point, the latter will automatically be modified to allow the signals to pass without virtually no attenuation. Although this means more noise will pass as well, it will have no detrimental effect on the result, since it will be 'masked' by the input signal. In other words, noise will be scarcely audible, provided it is accompanied by a strong

audio signal. The solution is therefore to limit the bandwidth to the 'bare necessities' and cut down the audible noise as much as possible.

One of the first manufacturers to base a noise reduction system upon the principle described above was Philips with its introduction of the DNL system in 1973. Then Burwen came up with its NR-2 system, the 'Dynamic Noise Limiter', followed by DNR from National.

Now that we know the whys and wherefores, let's get better acquainted with the two new noise limiters. First we'll find out the CBS 'news', only this time, not by listening to Walter Cronkite, but to the designers of CX, Gravereaux and Abbagnaro.

CX: Compatible eXpansion

CX was designed with a view to improving the dynamic range of record-players. The reason for this has already been discussed, but there is another important aspect to consider.

Modern recordings are made using digital multi-track tape recorders. This gives a dynamic range of 95 dB. By mixing a certain number of tracks (usually 24), additional noise is produced, resulting in a dynamic range of 81 dB. A modern record, on the other hand, has a maximum dynamic range of about 60 dB. The difference of 20 dB represents the dynamic improvement achieved by CX noise reduction.

The results involve compression during the recording and expansion during playback. As opposed to the other systems compression and expansion are frequency-dependent here. Since the CX system is compatible, CX recordings sound good even without expansion, although the 20 dB will have gone 'up the spout'. A CX 'decoder' costs about one hundred dollars, most of which goes towards the case and the power supply, which means the unit will be much cheaper once it is incorporated inside amplifiers (within the near future, we hope). In addition, the CX system provides an excellent transient response and the calibration required for the compression and expansion is not critical.

From figure 1 it can be seen that current controlled amplifiers are implemented during both compression and expansion. The control voltage for the amplifiers includes signal-dependent dynamics. The control current is derived from a left-hand and a right-hand audio signal by way of a peak detector and a set of 100 Hz high-pass filters. During the compression phase (figure 1a) these will be the two output signals, whereas the expansion phase (figure 1b) involves the two output signals. The control current for the left-hand current controlled amplifier is equal to that for the right-hand amplifier.

To find out how compression and expansion work, let's look at figure 2.

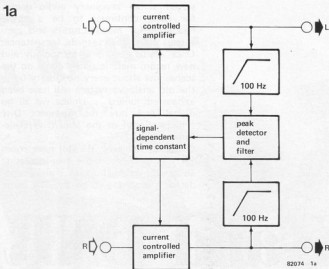

Figure 1a. Block diagram of the CX compressor.

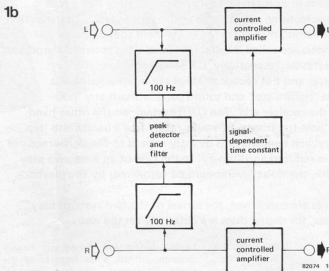

Figure 1b. Block diagram of the CX expander.

The graph related to compression is shown in figure 2a, where the levels of dB are indicated along the two axes. The input voltage of the compressor is situated on the horizontal axis and the cutting speed at which the signal is recorded can be seen on the vertical axis. Zero dB corresponds to a cutting speed of 3.54 cm per second. Without compression, there is a linear relationship between the cutting speed and the input level, as shown by the dotted line. At input levels above -40 dB, compression occurs in a ratio of 2:1. A change in input level of x dB results in a change in cutting speed of $\frac{1}{2}x$ dB. Below -40 dB, on the other hand, the 1:1 ratio is maintained, in other words, the signal is not compressed. Now for the expansion process illus-

trated in figure 2b. The input level of the expander is shown along the horizontal axis, which is related to the cutting speed of the record, or playback level. Again, zero dB corresponds to a cutting speed of 3.54 cm per second and the relationship between the cutting speed and the input level produces a straight dotted line at an angle of 45°. At recording levels above -20 dB expansion takes place in a ratio of 1:2. This means a change in recording level of 2x leads to a change in expander output level of 2x dB. No expansion occurs at levels below -20 dB.

The final result should be a 1:1 ratio between the input level of the compressor (horizontal axis in figure 2a) and the output level of the expander (vertical axis in figure 2b). As figure 2c

2a

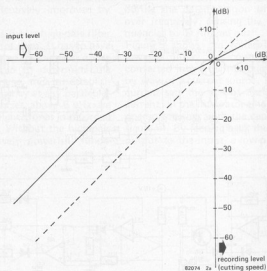

Figure 2a. The CX compression graph.

2b

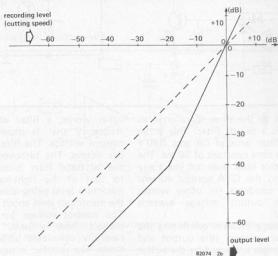

Figure 2b. The CX expansion graph.

2c

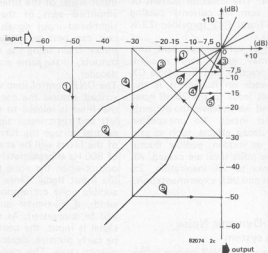

Figure 2c. The combined CX compression/expansion graph.

shows, this is exactly what happens. Input levels of -15 dB and -50 dB result in output levels of -15 dB and -50 dB, respectively. The two lines marked 3 refer to the transition from the vertical axis in figure 2a to the horizontal axis in figure 2b, both of which are related to the cutting speed. Thus, the signal returns well and truly to its original state after being compressed and expanded.

The break-points in the compression and expansion curves are symmetrical (mirrored) with respect to the total curve, this being the straight line in figure 2c at 45° to the axes. Should the break-point in one of the curves be slightly displaced due to the expander not being optimally calibrated, this will have no audible effect on the final product.

The CX 'decoder'

Figure 3 shows the circuit diagram for the CX expander. This may be included in the amplifier chain by connecting the circuit inputs to the tape outputs of the amplifier and the outputs to the tape 'play' inputs. By switching the recorder to 'monitor' and 'source' respectively, the situation including CX expansions may be compared to that without.

Both channels are provided with an input level control, P1 and P2. Both the L and R signals are amplified (up to 250 mVrms) by a factor of 2 (A1, A2) and are attenuated by way of R7/R9 and R8/R10 by a factor of 11, before being sent to the current controlled amplifier in IC4. IC4 incorporates two OTAs, amplifiers having a variable slope. The gain factor depends on the values of P5 + R17 and P6 + R18, respectively: P5 and P6 regulate the output level. The actual output voltage levels are produced by way of darlington-like buffers connected to the OTA outputs. The control current for the OTAs enters IC4 by way of pins 1 and 16. In both cases the control current is equal to half the collector current of T4. As it will soon be seen, the control current remains constant below a certain input level (-20 dB, see figure 2b). This means no expansion will occur.

A lot more happens in figure 3. By way of a high-pass filter with a turnover frequency of 100 Hz (C3/R21 and C4/R22) the left-hand and right-hand signals are fed to two full-wave rectifiers connected in series (A3...A6 and D1...D4). The voltage at the base of the emitter follower T2 is determined by whichever of the three following voltages is highest (a kind of analogue OR circuit):

1. a variable positive voltage produced by rectifying the left-hand channel;
2. as in 1. only now for the right-hand channel;
3. a DC voltage of a few tenths of a volt, determined by the supply voltage, R32, R33, T1, D5 and R31. In other

3

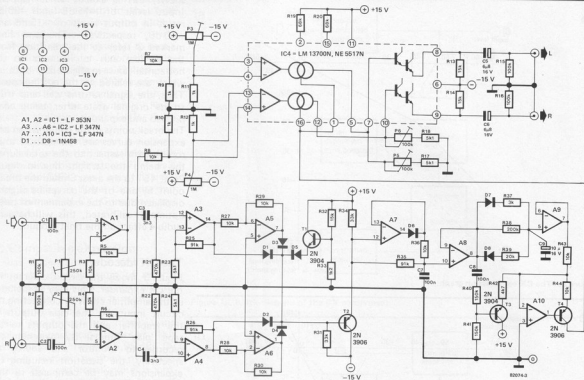

Figure 3. The CX expander ('decoder') circuit.

words, at expander input levels below a certain level (for L or R) the OTAs are provided with a constant control current, but if L or R exceeds that level the control current will be variable. This is due to the relationship between the collector current of T4 and the base voltage of T2.

After the signal has been buffered by T2, its positive peaks are rectified by A7 and D6, with the aid of C7, R36 and R35. Capacitor C7 is charged at a rate dependent on the time constant $R36 \cdot C7$. The product of C7 and R35 determines the rate at which C7 discharges (down to the input voltage of the peak rectifier at that moment, not down to 0 V). A second buffer A8 is followed by the section that provides the attack and decay times. These in turn depend on the signal level and that converts the control voltage into a control current for the OTAs.

The buffered output voltage of the peak rectifier is used to charge and discharge C9 at a certain rate. In the case of any slight voltage fluctuations, D7 and D8 are cut off (dead region). Both the attack and the decay times will then be determined by the product of R38 and C9, which will be 2 seconds. Significant changes in the positive level will cause D7 to conduct, producing an attack time of about 30 ms, which results from multiplying R37 and C9. D8 will conduct to instigate considerable changes in the negative level. As a result, the decay time will be related to the product of R39 and C9 = 200 ms.

In addition to the three mentioned so far, there is a fourth filter. This is the high-pass filter around C8 and R40 + R41 with a time constant of 30 ms. The output of this filter does not exert any influence on the OTA control current unless T3 conducts, in other words, unless the output voltage exceeds about 0.6 V.

The final stage involves converting the two control voltages (the output and emitter voltages produced by the buffer A9 and T3, respectively) into a corresponding OTA control current. This is done with the aid of A10, T4 and R42 ... R44. The collector current of T4 is the sum of currents passing through R43 and R42 (provided T3 is conducting!).

This system of voltage-dependent time constants may seem very straightforward in practice, but the whole CX system depends on it. For it is this principle that leads to the 20 dB noise reduction and which leaves the dynamic range almost intact. No unexpected attack and decay effects, such as gain modulation or sudden, audible fluctuations in the noise level are caused. All this is thanks to 2% inspiration, 2% transpiration and 96% experimentation.

The DNR: Dynamic Noise Reduction system

Figure 4 shows the DNR system in the form of a block diagram. The left-hand and the right-hand signals each pass a voltage controlled low-pass filter, in

other words, a filter with a turnover frequency that is dependent on the control voltage. The filter slope is 6 dB per octave. The turnover frequency of the left-hand filter is constantly equal to that of the right-hand filter, the minimum level being about 800 Hz and the maximum level about 30 kHz.

The control voltage for the filters is derived from a peak rectifier with carefully calculated attack and decay times. The rectifier is supplied with the amplified control voltage of a high-pass filter with a slope of 12 dB per octave and a turnover frequency of 6 kHz. The input signal of the filter consists of the amplified sum of the left-hand and right-hand input signals. The DNR circuit can best be included in the amplifier chain using the tape inputs and outputs, in the same manner as the CX decoder.

The DNR control loop we have just described ensures the control voltage for the filter is related to the level of the left and right input signals. At a zero control voltage the turnover frequency of the filters will be at a minimum level of 800 Hz approximately. This situation occurs when the noise predominates in the input signal. Since the amount of audible noise corresponds to the bandwidth, a maximum quantity of noise will be suppressed. As soon as a useful signal is input, the control voltage will be fairly positive, depending on the frequency range. This causes a higher turnover frequency in the filters and therefore less noise reduction. However, the useful signal is powerful enough to

drown the noise and so the signal-to-noise ratio is effectively improved by around 14 dB.

A word about the 6 kHz high-pass filter in the DNR control loop. It has to have this value because frequencies above 6 kHz are required to determine the filter control voltage, thus to establish the turnover frequency at any particular moment. Frequencies above 6 kHz are inherent to the higher tones in recorded music or speech. Without the high-pass filter, the (relatively powerful) funda-

mental frequencies would predominate during the determination of the turnover frequency, causing the higher frequencies to be filtered out!

Figure 5 shows the voltage controlled low-pass filter. The control voltage is converted into a control current, I_{ABC} , by way of a current source. The control current sets the size of the integration current i in the integrator (the right-hand opamp together with the capacitor C in figure 5). By feeding back the integrator output to the input, a low-pass filter is

obtained with a slope of 6 dB per octave and a turnover frequency ($f = 1 : 2\pi\tau$) that is dependent on the control current I_{ABC} . Readers who are interested can work out the formulae in figure 5 for themselves.

The circuit in figure 5 is part of an IC, type LM 1894, which National Semiconductor designed specially for the DNR system. Figure 6 shows the circuitry of the LM 1894. Together with a few external components it can be combined into a complete DNR unit. To the left of figure 6, inside the IC, readers will recognise the circuit illustrated in figure 5 and the summing amplifier which provides the amplified $L + R$ signal at pin 5. C_9 and R_1 , on the one hand, and C_{12} and the input resistor of the $26\times$ amplifier, on the other, create a high-pass filter with a turnover frequency of 6 kHz and a filter slope of 12 dB per octave. Pin 9 of the LM 1894 constitutes the input of the peak rectifier and pin 10 acts as the output, to which the storage capacitor C_{11} is connected. The rectifier output is internally linked to the V/I converter, the current source which provides the filters with the I_{ABC} control current. Pins 8 and 9 are linked by way of C_{10} . If the DNR circuit is to be used in an FM tuner, C_{10} will have to be replaced by a 19 kHz pilot frequency filter.

Figure 6 looks straightforward enough and readers are maybe already looking forward to constructing it for, say, £ 5. Unfortunately, the LM 1894 is only available to manufacturers once they have paid a considerable sum of money for the rights. It's not for the likes of us ordinary mortals...

Not to worry, there's bound to be an alternative and when we come up with one, our readers will be the first to know.

4

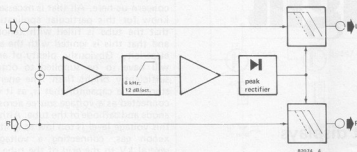

Figure 4. Block diagram of the DNR system.

5

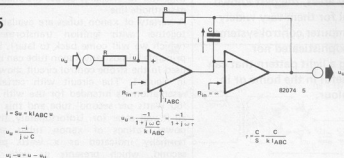

Figure 5. This is how a low-pass filter is constructed, in which the turnover frequency depends on a control current I_{ABC} .

6

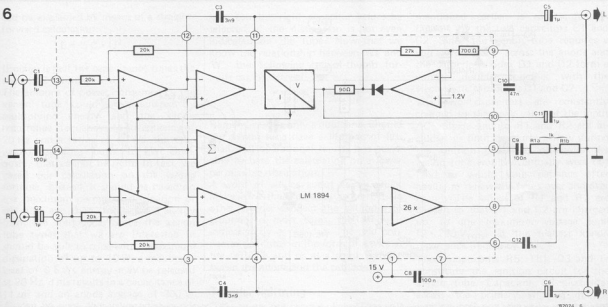

Figure 6. The DNR circuit diagram is straightforward thanks to its special IC. Unfortunately, the IC is not only special, it's rare...

strobe light control

an additional touch to light displays

Light displays feature on a grand scale in many areas, the best known probably being discos. The methods of control for them vary widely from audio sources to highly sophisticated computer control systems. The circuit described in this article is neither sophisticated nor complicated, but safe and capable of providing a light pattern that can be changed at will. It will probably be most useful in the home or in shop windows to add a little extra touch of colour.

Strictly speaking, a 'strobe' light is similar to the familiar neon light, since both involve a tube filled with inert gas. By connecting a voltage across the anode and cathode of the tube, a point will be reached at which the tube suddenly emits light. In other words the tube has 'ignited'. To put it quite simply: the tube is provided with energy in the form of a powerful electric field. The tube then reproduces this energy by emitting a bright flash of light. This sounds very straightforward, but in reality the process involved is far more complicated. However, that need not concern us here. All that is necessary to know for this particular application is that the tube is filled with xenon gas and that this is ignited with the aid of electricity. Obviously, plenty of energy will have to be supplied to obtain a sufficiently bright flash. The energy is stored in a capacitor that is, as it were, connected as a voltage source across the anode and cathode of the tube. Although this voltage level is too low to ignite the xenon gas, connecting a voltage of several kV to the grid of the tube (as a trigger in other words) will cause the capacitor to discharge across the anode-gas-cathode line.

A variety of xenon tubes are available together with ignition transformers (which we will come back to later). In principle, almost any xenon tube can be used in the strobe control circuit shown in figure 1. The circuit with certain reservations is intended for use with a '60 Watts per second' tube and this is all it will cater for. Unfortunately, the power ratings of xenon tubes are normally indicated as x watts per second, which presents us with a problem!

The reason for selecting the particular capacitor values and DC voltage level

1

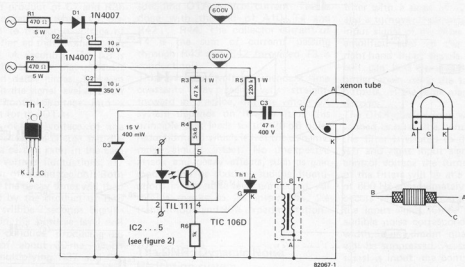

Figure 1. The strobe light control circuit. Electrolytic capacitors must have a high ripple rating. Tr is a special ignition coil for the xenon tubes (normally available from the same source).

2

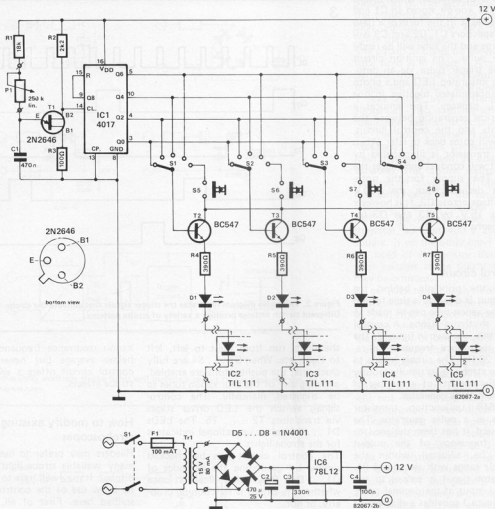

Figure 2. The control circuit can operate four strobe lights simultaneously. This section is electrically isolated from the rest of the circuit by means of an optocoupler.

can be explained by means of a straightforward calculation:

$$E = \frac{1}{2} C \cdot U^2$$

(Energy is half the capacitance times the squared DC voltage).

The amount of power consumed by the xenon tube could be calculated by multiplying energy and the xenon recurrence frequency. At a frequency of 20 Hz and a rating of 60 Ws, the tube would therefore 'burn' 1.2 kW! Obviously, that cannot be right. In fact, we based our calculation on the wrong formula. Instead, it should be based on the maximum permitted dissipation of the tube and then calculate the energy from the frequency. Since the xenon tube types that we are interested in should be able to cope with a maximum dissipation of up to 10 W, a maximum level of 0.5 Ws energy may be released at 20 Hz. This results in a capacitance of 11 μ F and an anode voltage of 300 V. As can be seen, this value corresponds reasonably well to C1 and C2 as indicated in figure 1. So far so good. But

how can the right capacitor values be selected, if the dissipation is not even indicated on the tube? Now that we know the relationship between 'Ws' and 'W', the following rule-of-thumb formula can be derived:

$$C1 = C2 = \frac{X \cdot Ws}{6} = \mu F$$

Remember it is only a guideline. Should the xenon tube have a lifespan of less than 250 operational hours, it is advisable to base the calculation on a lower permissible dissipation.

A word of advice about xenon tubes. Make sure their polarity is correct, in other words, connect the cathodes to ground. In most cases, the anode is indicated by a red dot. The grid connection is either in the form of a wire at the cathode end or as a third 'pin' between the anode and the cathode.

Tubular lightning

O.K., so gas can produce light. That still does not explain how the xenon tube is ignited. The energy storage capacitor

mentioned earlier is represented in figure 1 by the two capacitors C1 and C2. Since the xenon tube requires a voltage of 600 V across the anode and the cathode, diodes D1 and D2 form a voltage doubler together with the electrolytic capacitors C1 and C2.

The two capacitors are constantly charged to the peak value of the input AC voltage and so R1 and R2 are included to limit the current flow during the ignition phase, as otherwise the xenon tube would eventually wear out (and so would your patience after having to renew the fuses over and over again). The values of R1 and R2 are chosen so that C1 and C2 are charged up to the maximum voltage level ($2 \cdot 220 V_{rms}$) at the highest xenon recurrence frequency.

The components R5, Th1, C3 and Tr constitute the ignition circuit for the xenon tube. Capacitor C3 discharges across the primary winding of the ignition coil and the tube is provided with a grid voltage of several kV derived from the secondary winding. The tube

ignites, starts to conduct, which means it absorbs the energy stored in C1 and C2 and releases it in the form of a flash of light. Capacitors C1, C2 and C3 will then recharge and the tube will be ready for a new pulse. The ignition circuit receives the trigger pulse via an optocoupler, an integrated LED and a photo transistor encapsulated together in one plastic DIL package. This ensures a good electrical separation between the strobe lights and the control circuit, which we will come back to later. When the photo transistor is illuminated by the LED, it will conduct and trigger the thyristor. The supply for the optocoupler is derived from the 300 V ignition voltage across C2. It is however reduced to 15 V by R3 and D3 for obvious reasons.

The control circuit

Now that the principle behind the control circuit is clear, it is time to find out how the xenon tube can be made to generate a rhythmic strobe. A control circuit for this is shown in figure 2. The maximum recurrence frequency is restricted to 20 Hz. The circuit is able to control four strobe lights simultaneously and basically consists of a number of switches and a clock generator.

The 2N2646 unijunction transistor (UJT) acts as a pulse generator. The circuit around it has been designed to allow the frequency of the output signal to be adjusted within the 8...160 Hz range with the aid of P1. The oscillator signal is passed to the clock signal input of the decimal counter IC1. Figure 3 provides a diagram of the signal wave forms at the outputs of IC1 with relation to the clock signal. The signals have a frequency of 1...20 Hz and are fed to switches S1...S4. The setting of the switches determines the strobe pattern, whether

3

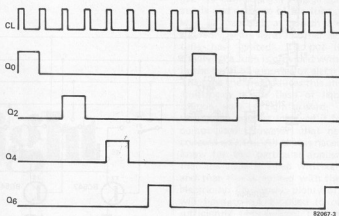

Figure 3. This pulse diagram illustrates the trigger signals that activate the strobe lights. Different switch settings produce a variety of strobe patterns.

the lights run from right to left, left to right, etc. When S1...S4 are fully clockwise, the pushbuttons are enabled, allowing any of the four xenon tubes to be triggered manually. The control signals switch the LED driver stages via transistors T2...T5. The LEDs D1...D4 act as operational indicators for the strobe lights.

The control circuit can be checked simply by grounding the cathodes of D1...D4. They will indicate at once whether the circuit is functioning properly, or not.

Figure 4 illustrates a suggested front panel layout. It shows a rather peculiar setting however; tubes A and B will light simultaneously, while tube D will not fire until two clock cycles later and tube C must be operated manually. The

xenon recurrence frequency is slightly below average but nevertheless, this control circuit offers a wide range of strobe effects.

How to modify existing stroboscopes

Readers may prefer to use one of the many available strobe light 'boxes' as a display. It may well have to be modified to allow use of the control circuit described here. First of all, be sure to unplug the strobe lights, to start with! Then take the device apart with a screw driver and examine its interior. Take care not to 'short' the capacitors because they can still be charged, a rather painful sensation. The higher voltage

4

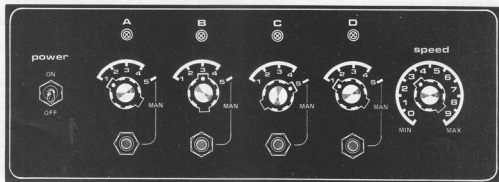

Figure 4. An idea for the front panel of the control circuit. The LEDs act as operational displays for the strobe lights. The strobe effect can be controlled manually by setting the switches in the 'MAN' position.

5

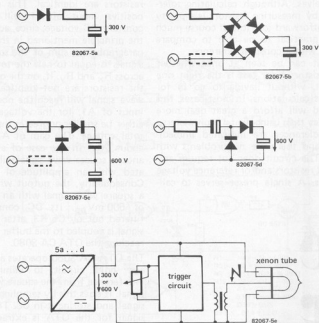

Figure 5. Commercially available strobe lights will include a circuit that is basically similar to one of those shown here.

6

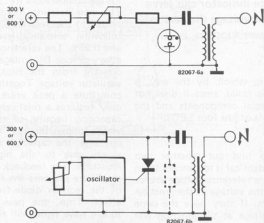

Figure 6. Two possible xenon tube ignition circuits. The more sophisticated version (b) has been used here.

should be produced in one of the manners indicated in figure 5. This is what the circuit should basically look like. It must supply a voltage of 300...600 V depending on the type of xenon tube used. The circuit may contain a few more resistors. The xenon electrolytic capacitor is usually a special type due to the powerful discharge current. Figure 6 illustrates the most frequently

used trigger circuit. Figure 6a shows a straightforward version containing a xenon tube. The capacitor is charged by means of an adjustable resistor. The internal resistance of the xenon tube drops to a low level and 'fires'. Strictly speaking, therefore, the capacitor is connected in parallel to the primary winding of the ignition transformer and the full amount of the stored energy is

passed to it. The secondary winding of the transformer provides the extremely high voltage (some kV) required to ignite the xenon gas.

The circuit in figure 6b shows the xenon tube fired as in figure 1. A control pulse derived from the oscillator can either trigger the thyristor as shown in figures 1 and 2, or by a different method altogether. This explains why only the 'oscillator' section is included in figure 6b. The potentiometer is not absolutely necessary. In this particular case, the flash frequency will of course not be variable. The dotted resistor is only required at a voltage of 600 V. It has the same value as the resistor in the anode lines of the thyristor. Thus, only half of the voltage passes through the thyristor, so that 400 V types are adequate. If on the other hand readers can get hold of a thyristor that can cope with voltages above 600 V, the resistor may be omitted.

To get back to our analysis of the strobe lights, the device must be reconstructed, so that the ignition circuit ends up looking like that shown in figure 1. If the majority of components are already available, only the optocoupler and the power supply including D3, R3 and R6 will have to be added. The ignition stage which consists of Th1, Tr, R5 and C3 will not need to be modified, even if the component values differ from those indicated here. If the ignition circuit is driven on 600 V, the value of R3 will have to be increased to a 100 k/1 W type. A resistor with the same value as R5 should be connected between the anode of Th1 and ground, unless such a resistor is already provided. Now the strobe lights will be able to be used with the control circuit.

Construction

The circuits in figures 1 and 2 can best be mounted on a piece of Veroboard. The stroboscope is constructed four times. Since the duration of the flash depends both on the value of the xenon capacitor and on the resistance of the wires, the connections to the xenon tube should be made with fairly heavy cable. C1 and C2 must be high quality electrolytic capacitors. 'Normal' electrolytic capacitors are bound to go into orbit. All capacitors should have a high ripple rating. The thyristor does not need to be cooled.

The ignition transformer is often sold together with the xenon tube. The circuit in figure 2 is quite straightforward to build, but one thing must be remembered: the ground line should be connected only to the LED cathodes of the optocouplers.

The reflector for the xenon tube can either be made of a piece of card covered in aluminium foil or from an old car headlight. Make absolutely sure the case does not come into contact with the power supply. This could be fatal!!!

The advantages of the circuit speak for themselves. Although calculating tolerances by measuring resistors is a pretty straightforward job, it is of course much more practical to be able to compare values with a constant reference.

Now it can be seen at once whether the resistor under test is the right one or not, without having to go in for tedious calculations. In most cases, this method will afford a great deal more accuracy than using digital multimeters. The tolerances are indicated immediately and there are no problems with drift. The circuit does not require any critical resistors and/or reference voltage sources. A single preset serves to cali-

Let us assume for the moment that the resistors are identical. This means the positive input of A1 will receive a constant DC voltage, since, according to the principle mentioned in the previous paragraph, the sum of the square wave signals is equal to half the total voltage across R_X and R_Y . If, on the other hand, the resistors are not identical, a square wave signal will reach the non-inverting input of A1, for the voltage here will either be smaller or greater than half the total voltage. The gain of A1 is set at about 20x. In the case of a 1% tolerance, a square wave signal will be generated with an amplitude of 25 mV_{pp}. Consequently, the output will produce a square wave signal with an amplitude of 500 mV_{pp}. Its DC constituent is filtered out by C5/R3, after which the signal is coupled to the buffer A2 before reaching the OTA CA 3080.

The OTA CA 3080 operates as a sample and hold circuit to eliminate any interference from the square wave input signal. It does this by sampling the input signal and storing it in C8. The control signal for the OTA is extracted from the 'normal' and the inverted oscillator signals. The control current for the OTA circuit is obtained by way of the integrators R28/C13 and R29/C14, the differentiator C16/R6 and the transistor T1. Gates N5...N7 act as buffers. N8 links the two input signals so that they form a control pulse lasting about 22 μ s. As a result, there will be a 'clean' square wave signal across the storage capacitor for the comparators B1...B3.

The non-inverting inputs can be connected to the 'reference voltage' for the following tolerance levels: 1%, 0.5% and 0.25%. The reference voltage is not a very precise DC voltage, but is derived directly from the peak value of the oscillator voltage. Together, A3 and A4 constitute a peak value rectifier. This only requires a relatively small storage capacitor, because of the buffer, A4, which follows the 'real' rectifier D1. In any case, the capacitor discharges very slowly due to the high 4M Ω input resistance. The feedback across the two amplifiers prevents the forward voltage of the rectifier diode from having any effect. Thus, the peak value of the square wave signal will always reach the rectifier output, irrespective of its absolute value.

Any change in the amplitude of the resistors under test, in other words, any change at the input of A3, will exert a direct influence on the level of the reference voltage. This means that the comparator voltages will always be in the same proportion to the input (test) voltage. The circuit therefore adjusts itself, so to speak. As a result, even fluctuations in the power supply voltage will have no effect whatsoever on the stability of the tolerance indicator, so that the circuit can make do with a non-stabilised ± 15 V power supply.

What about the display circuit? The reference voltage is divided by R8/R9

tolerance indicator

accurate matching to within 0.25%

This useful circuit helps to match resistors by comparing their values and indicating any difference between them. This enables tolerances as low as 0.25% to be calculated with accuracy. The circuit does not even need to be calibrated! The tolerance indicator can serve all sorts of purposes: it can measure resistances for voltage dividers in synthesisers and other electronic instruments, power supplies, measuring devices and D/A converter networks.

brate the unit, which, by the way, is very cheap to build, since it does not need any special components and the display consists of just four LEDs.

The circuit

One way to find out whether two resistors are identical is to connect them in series with a reference voltage source and measure the voltage at the junction between them. If they have the same value, the voltage at the junction will be half the reference voltage. A reference voltage of 10 V, for example, will give a result of 5.00 V. If the level measured does not coincide, the difference can be calculated by a straightforward subtraction, and we're left with the tolerance.

A far less complicated solution involves the circuit in figure 1.

A CMOS IC, type 4093 (IC1) acts as an oscillator and generates two square wave signals that are phase shifted by 180° with respect to each other and have a frequency of 4...5 kHz. These signals are passed to the two resistors under test, R_X and R_Y . The other ends of the two resistors are connected to the positive input of the opamp A1.

H.P. Baumann

1

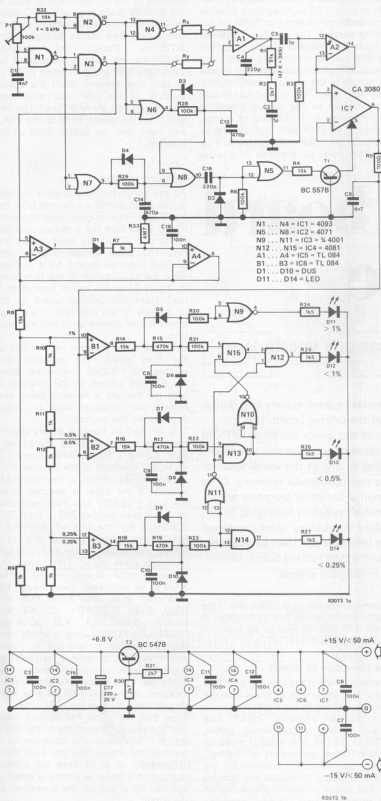
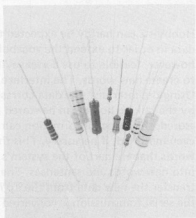

Figure 1. The tolerance indicator circuit does not contain any special or critical components, but can nonetheless measure tolerances as low as 0.25% with great accuracy.

and is fed to comparator B1 directly and to B2 and B3 via R10...R13. The comparators will switch as soon as the voltage at the inverting inputs reaches or exceeds the reference voltage levels at the non-inverting inputs. The integrating networks R15/C8, R17/C9 and R19/C10 shape the switching signals for the logic circuits following them. The latter makes sure only the LED that is 'valid' at any particular moment lights. Tolerances less than 0.25%, however, will continue to be indicated by the 0.25% LED. The other LEDs represent 0.5%, 1% and > 1%, respectively. The > 1% LED lights when the test terminals are open.

The circuit is very easy to calibrate. P1 is adjusted for an oscillator frequency of 5 kHz. An oscilloscope or frequency counter would, of course, be ideal here, but it can also be verified with a multimeter. Use two resistors with the same value, say, 10 k Ω , for R_X and R_Y. Set P1 in the centre position. Connect a multimeter in the 10 V range to the junction of the two resistors and check whether the voltage at this point is about 3.4 V. If not, turn P1 until the right value is reached. Readers who don't possess any of the meters mentioned should set P1 in the centre position. \blacksquare



82073 1b

The interface serves to transfer digital information from the talking board to the computer (RAM) memory. Since the talking board transmits bits at intervals of only 12.5 μ s, they can't possibly be transferred directly to RAM in the microprocessor. The interface, as shown in figure 1, consists of a buffer, in which the data can be temporarily stored, and several IC's which look after the necessary timing of the various control signals. Only four wires are needed to connect the interface to the talking board by way of points D, U, I/O and of course, ground. The EXP wire link should be removed from the talking board. Five I/O lines must be available in the μ p

while the I/O timing (to control the address counters in the speech ROM's) clocks a frame. As can be seen, data entering at the D input must be valid on the positive going edge of an I/O pulse. In addition, the figure shows that the actual data flow occurs during the first 3.125 ms. During the remaining 21.875 ms, no data is transferred between the VSP and the speech ROM. (It is true that samples reach the speech outputs of the VSP, but these have no relevance to the interface.) The data sent from the speech ROM to the VSP is also read into the buffer RAM of the interface.

talking board interface

... extends the microprocessor's vocabulary

Hobbyists can hardly be expected to translate speech signals into digital data in order to extend the vocabulary of the talking board. It is however, feasible to use certain syllables of the words stored in EPROM to create new words. The interface described here makes this possible. Using the interface, the data corresponding to one of the words uttered by the talking board can be stored in the microprocessor memory. Once stored, the speech information can be applied for other purposes and even modified, if necessary. This then enables syllables belonging to words that are part of the system's standard vocabulary to be combined into new words and sentences. The same interface can then be used to transfer the new data from the μ p memory to the talking board, where the serial transmission is converted into intelligible speech.

system: Three act as outputs, one is the output which leaves one to function as a real I/O line (it can be an input or an output, as required).

The structure of words

In order to understand how the interface works, it is important to know how the talking board words are structured.

Let's take an example: 'HELP' (see table 3 in the talking board article, E. '80, p. 12-04). The word is made up of 25 different parameters or 'frames'. After the 'TALK' command, the TMS5100 starts to read in and process the first frame. A new frame is read in and processed every 25 ms. Depending on the type of sound that is to be emitted, the number of bits belonging to a frame may vary between 4 and 49. Figure 2 shows the time sequence chart

Reading in data

All the signals required to store the data in the RAM buffer are derived from the I/O signal. The microprocessor merely has to make sure the interface counters (IC3a and IC3b) are reset before the first I/O pulse arrives. This is why CLEAR becomes logic 1 for a moment after the initialisation in the flow chart in figure 3, which shows how data is read from the talking board to the μ p by way of the interface. The talking board is not started until this has been done.

Let's see what happens in the rest of the flow chart. The program now reaches the FRAME subroutine. Since the FRAME output of the interface is high (to indicate a frame is being processed) the computer waits for about 4 ms during this routine.

The left-half of figure 4 shows exactly how the buffer RAM is loaded with data during a frame. After every I/O pulse, the contents of the counter IC3a is incremented by one, so the next RAM address in the series is selected. After the four ENERGY bits have been read in, it will take another $250 - 7 \times 6.25 = 206.25 \mu$ s for the bits of REPEAT + PITCH to arrive. During this time MMV2 will be deactivated and IC3b will receive a clock pulse. This causes the following byte (8 bits) in the buffer RAM to be addressed. Even though the data read in is only 3 bits (K8, K9, K10), 4 bits (ENERGY, K3, K4, K5, K6, K7), 5 bits (K1, K2) or 6 bits (REPEAT + PITCH) long, a whole byte (8 bits) location is reserved in RAM. This makes no difference, anyway, as there is plenty of memory space in the buffer (up to 12 blocks of eight memory locations are occupied for a frame, even though there is room for 1024 bits).

Now that we're on the subject, note that the address lines of the buffer RAM are not linked to the counters in a symmetrical order. This has been done deliberately so as to keep the printed circuit board design as simple as possible and has no effect on the operation of the circuit.

After the 4 ms interval mentioned earlier, the data transfer of that particular frame will be complete, as, after all, it only takes 3.125 ms to send a frame.

1

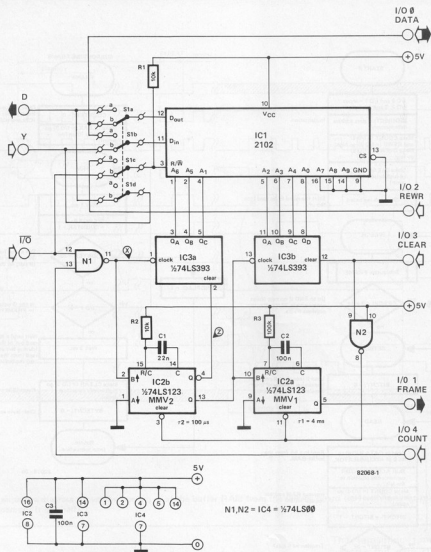

Figure 1. The circuit diagram of the talking board interface: a RAM, two counters and two mono stable multivibrators.

2

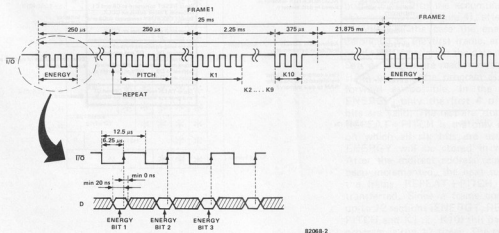

Figure 2. This time sequence diagram shows how a frame is constructed.

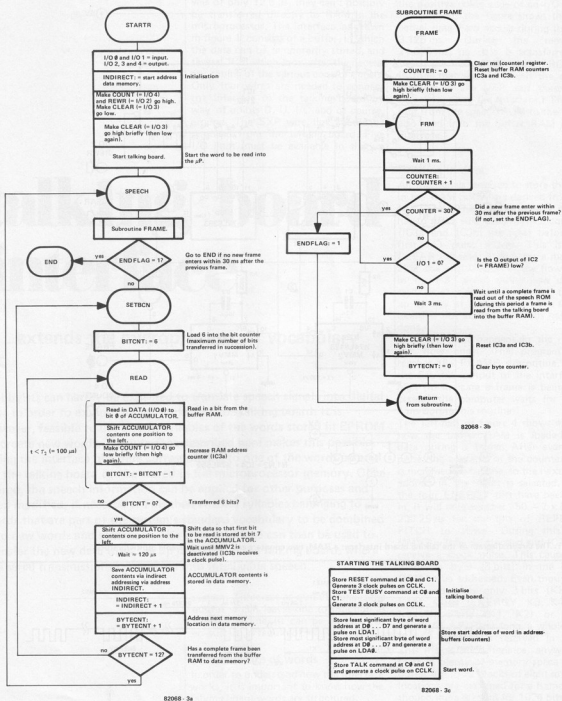
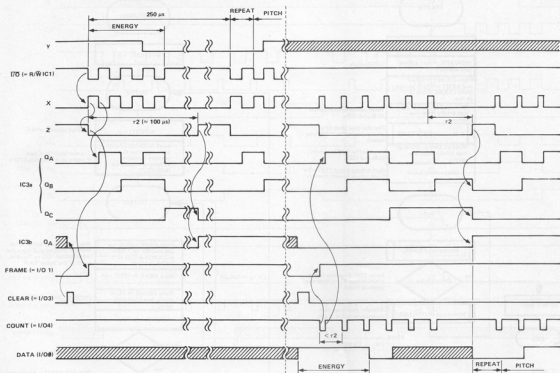

Figure 3. Flow chart for reading in the buffer RAM from the talking board and reading out from RAM to the microprocessor's memory.

4



82068-4

Figure 4. This time sequence diagram shows the reading in of the buffer RAM from the talking board (left-half) and the reading out from the buffer RAM to μ p memory (right-half).

5

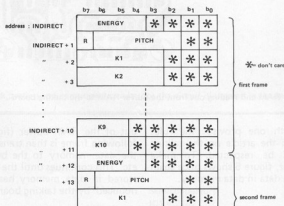

82068-5

Figure 5. The information is stored in the data memory of the microprocessor in this manner.

The remaining time can be used to transfer the data stored in the buffer RAM (the first frame) to the μ p RAM. First of all, the counters IC3a and IC3b are reset. Then the FRAME subroutine is left which brings us to READ. This section reads the first six bits of the buffer RAM into the accumulator (see the right-half of figure 4), after which the bits, in the case the energy bits belonging to the first frame, are stored at the first location in the data memory. Sets of six bits are read from the buffer RAM to keep the program as straight forward as possible. In the case of ENERGY, only the first 4 of the six bits are valid. The rest are 'don't care'. REPEAT + PITCH is the only occasion on which all six bits are used. Now ENERGY will be stored in memory. After the indirect address register has been incremented, the next section of the frame, REPEAT + PITCH, may be transferred. Since a frame consists of up to 12 sections (ENERGY, REPEAT + PITCH and K1 . . . K10) this part of the program is run 12 times. The computer then returns to the FRAME subroutine where it waits for the arrival of a new frame.

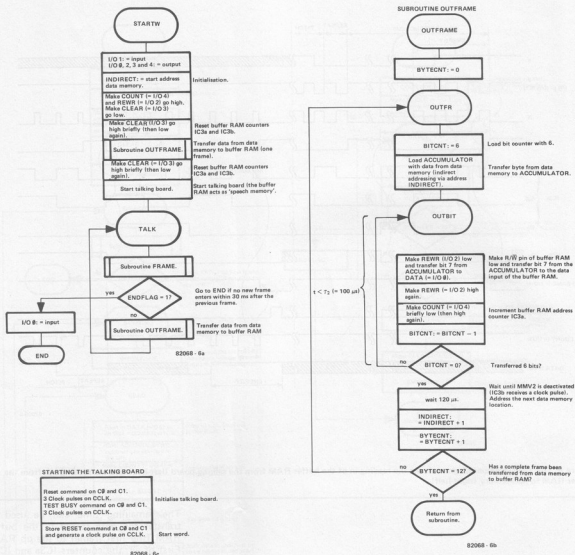

Figure 6. Flow chart for reading in the buffer RAM from the μP RAM and reading out from the buffer RAM to the talking board.

From the above, readers might think a frame always contains 12 elements. This is not always the case. If all the bits in ENERGY are low (0000), for instance, the frame will only contain one unit. But things would get far too complicated if the program were to be made such distinctions. This is why this particular method has been chosen, with the disadvantage that data memory is disposed of rather liberally.

At the end of the word, the ENDFLAG goes high and a jump is made to END. The uttered word will now be completely stored in μP RAM. The data it contains can be altered as much as

required with one proviso: the rules stipulated in the article on the talking board must be respected. To make things clearer, figure 5 shows once again how to store data in data memory.

Reading data from memory

Data is read from the data memory RAM as shown in the flow chart in figure 6 (the switch S1 will be in position a). Initially, the first frame in the buffer RAM is read by means of subroutine OUTFRAME (see left section in figure 7). The talking board is then activated and can read the first frame

out of the RAM buffer (figure 7). The following frame is then transferred from the data memory to the buffer RAM, etc. This continues until the entire word stored in data memory has been 'pronounced' by the talking board.

The printed circuit board

The printed circuit board design for the interface circuit in figure 1 is shown in figure 8. The board is highly compact, so there is bound to be room left to fit it in. Points 0 and + are connected to a power supply of 4 V. Points D, Y and I/O are linked to the corresponding pins

7

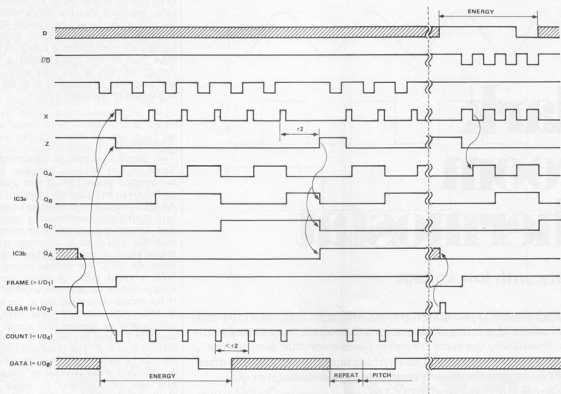

82068 7

Figure 7. Time sequence diagram for reading in the buffer RAM from the μ p RAM (left-half) and reading out from the buffer RAM to the talking board (right-half). Switch S1 has to be in position a.

8

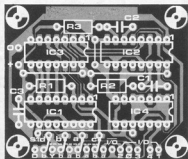
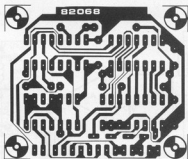

Figure 8. Track pattern and component overlay for the circuit illustrated in figure 1.

Parts list

Resistors:
R1, R2 = 10 k
R3 = 100 k

Capacitors:
C1 = 22 n
C2, C3 = 100 n

Semiconductors:
IC1 = 2102
IC2 = 74LS123
IC3 = 74LS393
IC4 = 74LS00

Miscellaneous:
S1 = 4 x way switch

on the talking board, whereas the five I/O connections are made to the microprocessor. Finally switch S1 must be wired. The position of this switch determines whether data is written into or read out of the RAM. In position a the data is transferred from RAM to the talking board and in position b it is transferred from the talking board to RAM.

Using the flow charts provided, a program can be written, according to the processor utilised, to write and read the pronounced word. **M**

dark room thermostat

safety with low voltage

The photographers amongst our readers will agree that one of the most critical points of printing photographs is the correct temperature of the baths. Specifically the paper developer needs a constant temperature, otherwise the photograph will be anything but brilliant. With the often used PE photographic paper it is strongly recommended that the temperature is maintained at 20°C. The circuit described in this article takes care of that.

It will be obvious that not too much extra energy is required in the developer bath, assuming that the temperature in the dark room doesn't drop below 16°C. This fact offers the possibility to use a heating element having a lower voltage than that of the mains. Such a low voltage element is not only safer, but also very easy to construct with the aid of a length of resistance wire.

The circuit

The circuit diagram is illustrated in figure 1 and consists basically of a temperature sensor (A1), a zero crossing switch (A2) and a Schmitt trigger (A3). An NTC (resistor with negative temperature coefficient) functions as a temperature sensor and it serves its purpose perfectly well since its non-linearity to temperature is only of minor importance. At 20°C the voltage across the NTC is about 0.5 V. A corresponding voltage can be set with the wiper of P1. If the temperature measured at the NTC is below the required level, then its voltage will be beyond that across the wiper of P1 and the output of A1 will therefore go low. The threshold level of A1 can be varied by R13. Without this resistor very small changes in temperature will be sufficient to make A1 change its output level. If a resistor of about 5M Ω is chosen for R13, then an

1

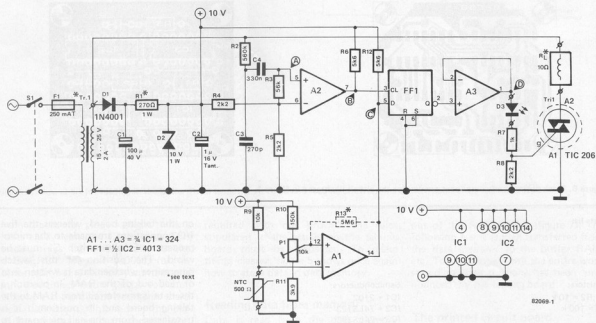

Figure 1. The circuit diagram of the safe dark-room thermostat. The upper section contains the zero crossing switch and the lower section contains the temperature sensor with a Schmitt trigger.

alteration of at least 1°C is required to change the output level. The smaller R_{13} , the greater the hysteresis will be.

The Q-output of the flip-flop will become logic 1 at the first positive edge of its clock input after the output of A1 goes low. The clock input of this flip-flop is a square wave voltage that changes its level with the zero crossing point of the transformer AC voltage. For this, comparator A2 is wired as a pulse shaper and converts the 50 Hz sine wave input signal into a square wave voltage. It will be seen from the various levels in figure 2 that the output only changes state at the positive going zero crossing point of the mains frequency. A3 forms a buffer between the flip-flop and the triac (TRI1) since the CMOS flip-flop is unable to supply enough current to operate the triac. LED D3 indicates when the circuit is in operation. In order to avoid any problems in the dark room it is very wise to use a red LED.

Construction

The construction of the circuit is simplified with the aid of the printed circuit board shown in figure 3. Making the heat element from a length of resistance wire takes some more time. The wire can be placed either in or under the bowl. However, experience

Parts list

Resistors:

$R1^* = 270 \Omega / 1 \text{ W}$
 $R2 = 560 \text{ k}$
 $R3 = 56 \text{ k}$
 $R4, R5, R8 = 2\text{k}2$
 $R6, R12 = 5\text{k}6$
 $R7 = 1 \text{ k}$
 $R9 = 10 \text{ k}$
 $R10 = 150 \text{ k}$
 $R11 = 3\text{k}9$
 $R13^* = 5\text{M}6$
 $\text{NTC} = 500 \Omega$
 $P1 = 10 \text{ k}$ (multiturn)

Capacitors:

$C1 = 100 \mu / 40 \text{ V}$
 $C2 = 1 \mu / 16 \text{ V}$ Tantalum
 $C3 = 270 \text{ p}$
 $C4 = 330 \text{ n}$

Semiconductors:

$D1 = 1\text{N}4001$
 $D2 = 10 \text{ V} / 1 \text{ W}$ zener
 $D3 = \text{LED}$ (red)
 $\text{Tr}1 = \text{TIC} 206$
 $\text{IC}1 = 324$
 $\text{IC}2 = 4013$

Miscellaneous:

$\text{Tr}1^* = 15 \dots 25 \text{ V} / 2 \text{ A}$ transformer
 $S1 = \text{dpdt}$ mains switch
 $F1 = 250 \text{ mA}$ slow
 $R_L = \text{resistance wire}$
 fuse holder
 heat sink for triac

*see text

2

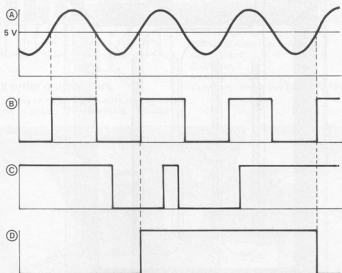

82069-2

Figure 2. This figure shows the voltage levels at various points of the zero crossing switch.

3

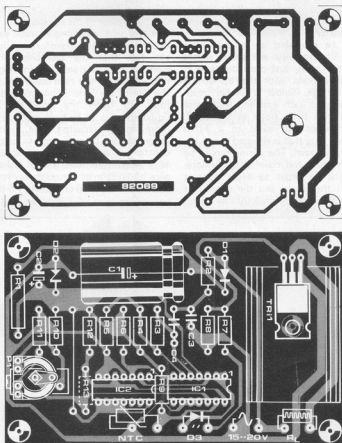

Figure 3. The copper track pattern and component overlay of the printed circuit board.

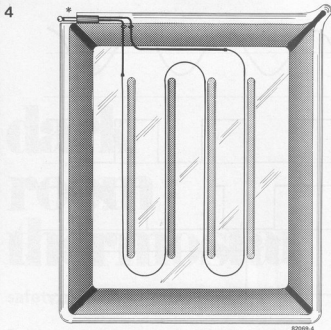

Figure 4. This figure illustrates how the resistance wire, which functions as a heating element, can be mounted inside the bowl.

has shown that the wire functions better inside the bath, because of the improved heat transfer.

It can be mounted as follows. First 'solder' it carefully at several places inside the bowl, just push the wire in the plastic bowl with the tip of the soldering iron. Solder a thicker, insulated wire at each end and lead these out via two little holes in the bowl. Then connect the wires to a 3 mm telephone plug that is situated under the edge of the bowl. The wiring should be fixed in place and covered by Araldite or similar in order to avoid contact between the liquid and the wire. This should be done carefully to avoid

electrolysis which may occur, due to the basic character of the developer.

The size of the heating element will be dependent on the transformer, due to the fact that the resistance of the element and the transformer voltage are responsible for the heat dissipated. Also the size of the bowl plays an important role. The larger the bath, the more liquid there is to be kept warm, so the more energy required. The following values should be sufficient to obtain a constant temperature: In a bowl of 18 x 24 cm (0.5 litres) 1 m of resistance wire of 10 Ω /m at a transformer voltage of 15 V. A 30 x 40 cm bowl (1.5 litres) needs 2 m wire of 5 Ω /m and a trans-

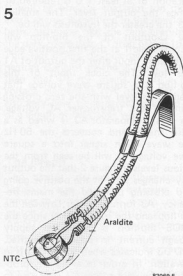

Figure 5. The NTC can be placed in the dish and covered with Araldite.

former voltage of 20 V. It is therefore wise to choose a transformer with several taps on the secondary winding. The NTC must be glued or suspended in the liquid as illustrated in figure 5. Where construction is concerned only one point remains, the value of R1 is dependent on the transformer voltage. The formula is as follows:

$$R1 = \frac{\sqrt{2} \cdot U_{tr} - 10}{0.04} = 25 \cdot (1.4 \cdot U_{tr} - 10) [\Omega]$$

Practical hints

The circuit must be calibrated before it can be put into operation. To do this the NTC is immersed in water having the correct temperature and P1 is adjusted until the voltage on the wiper reaches a minimum. Then turn P1 in the opposite direction until the LED is just about to go out. This completes the calibration.

Of course, it is possible to control the temperature of the fixer as well. There is a simple solution to that problem: supply both bowls with a heating element, using a transformer that is able to supply the current required. Furthermore the triac must be sufficiently cooled; a heat sink the size of the one drawn on the printed circuit board will take care of that. The maximum current of the triac is 3 A. If you want to heat both bowls, they should be the same size and contain equal amounts of liquid. The fixing solution will keep its temperature fairly well if it is heated first. It is evident that better results will be achieved with one dark room thermostat per bowl.

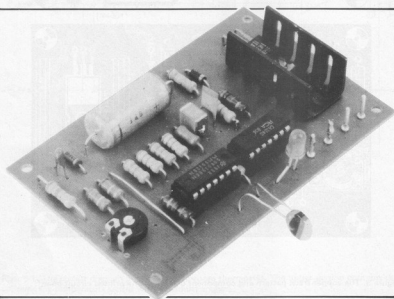

missing link

Junior Computer Book 3 Combining the Junior with the Elekterminal

Readers who added the Elekterminal extension to their Junior Computer may find that the PM program causes 'UNIOR' instead of 'JUNIOR' to appear on the TV screen. This usually happens at the beginning of a new line, in other words after the computer has executed the CR and LF instructions (Carriage Return and Line Feed). It takes the computer more time to carry out these two commands than to print characters. The maximum baud rate for the Elekterminal is 1200. A higher baud rate would lead to all sorts of problems and this is exactly what has happened to several readers because certain types of the 4024 IC (IC14 and IC15 of the Elekterminal) produce a baud rate that is too high. IC14 will then divide by 7 instead of 13. The only suitable 4024 types have a low minimum reset time specification, such as the ones manufactured by Fairchild, National, Philips and Toshiba. In any case, the preset baud rate can be checked by comparing the contents of memory locations S1A5A (CNTL) and S1A5B (CNTH) after the start of PM. At a baud rate of 200 CNTH and CNTL will contain 00 and 1B, respectively. Book 3 describes how to adjust the Elekterminal to a baud rate of 1200. The S2a/S2b switch must be omitted, Figure 10 on page 141 is misleading: the wiper connection of S2b ('MS2b') should be linked to ground. 'MS2b' is represented by the connection at the far left, whereas ground is at the far right.



Talking board (E80)

A printers error occurred in the listing for EPROM 2 (Table 4). The word 'seventeen' is shown stored at address 0864. This should be 086A.

The interface connections to the Junior Computer (see figure 8) mentioned in the article only refer to the JC in its extended version. In order to interface the talking board to the main JC board (without the extension) the following alternations have to be made to the left of the interface circuit diagram: A13 must be replaced by A12, A15 by K4 (and a 1 K pull-up resistor) and A12 by A13. The interface address range will then be: 1000... 1003 instead of 2000... 2003.



Revolution Counter (E77)

Unfortunately, the counter counts two pulses instead of one for every revolution. To rectify this, link pin 3 of Schmitt trigger N8 to the count inhibit input (pin 26) of IC1. Pin 26 is grounded on the board printed circuit board, so that some tracks will have to be broken.

market

Mail order multimeters

The Sanwa range of high quality multimeters is now available to electronics enthusiasts

(2238 M)



D.I.Y. Factory

This factory has been designed to fill the needs of many who require a little extra covered area. It is available in a variety of shapes and sizes and is complete down to the last nut and bolt. Parts are manufactured in ready coloured steel and concrete for maximum durability. Erection is fairly straightforward and can be completed in 10 to 12 months with the help of a friend.

A handy booklet containing step-by-step instructions and exploded diagrams for as-

sembly is given free when the D.I.Y. Factory is purchased as a complete kit. The manufacturers state that for best results some knowledge of site leveling, concrete mixing and crane driving are to be desired.

It is regretted that, for technical reasons, kits cannot be sent by post.
With apologies to:
*NEC Semiconductors (UK) Limited,
Livingston,
West Lothian.*

(2239 M)

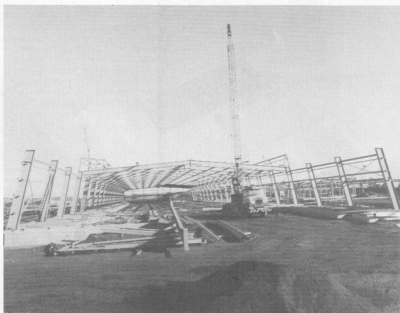

market

S40A EPROM programmer

Elan Digital Systems Ltd has announced a new economy model programmer, the S40A. All the important basic functions are included such as: Key selection and programming of single and three rail EPROMs up to 64 K sizes; full protection of these devices with English display of the exact failure conditions; extensive editing facilities; and key selection of RS 232 I/O interface.

Added features are:

1. All functions are key selectable without switches or personality modules, including device type, baud rates, formats and codes.
2. Programming time is shortened without altering the device manufacturers specifications. As little as a single byte may be programmed virtually instantly on a previously programmed EPROM.
3. Shorted data and address lines are isolated to allow immediate and exact knowledge of which lines are shorted together. The unit may be used for automatic bare pcb testing and goods inwards verification.
4. Independent selected areas of RAM and EPROM may be verified to give increased confidence after editing.
5. English ASCII code may be entered and scroll displayed directly. This will allow the new higher level language microprocessor to be programmed directly.
6. Byte strings may be searched and exchanged automatically, and after block moves, absolute and relative addresses may be adjusted to coincide automatically.
7. The principal programming and verifying functions may be fully controlled re-

motely. The unit has been designed to accept Data I/O or equivalent codes to allow direct replacement on computer or development systems.

8. The S40A may now be expanded to the S50A EPROM Debug Simulator (EDS) which offers extended facilities for automatic break points, single stepping, target system register and RAM control as well as multiple PROM simulation.

The new high quality all metal housing of the S40A gives added durability while still allowing portability with the battery back-up option.

*Elan Digital System Limited,
16-20 Kelvin Way,
Crawley,
West Sussex RH10 2TS
Telephone: 0293.510448/9*

(2241 M)

RFI filters

Available now in the UK from sole Agents MCP Electronics Limited, the new SK (Super K) series is designed to reduce conducted noise to acceptable limits and is ideal for equipment generating noise to the power

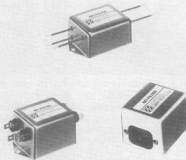

line or with high line to ground and line to line conducted emissions.

Electrically available in 3, 6 and 10 amp at 115 VAC, and 1.5, 4 and 6 amp at 250 VAC, the VSK version has a maximum leakage current of .5 mA at 115 VAC and 1.25 mA at 250 VAC. All offer a choice of termination styles; non rotating quick connect/solder, wire termination, or IEC connector.

*MCP Electronics Limited,
38 Rosemont Road,
Alperton,
Wembley,
Middlesex HA0 4PE,
Telephone: 01.902 6146*

(2245 M)

Fibre optics evaluation kit

An inexpensive fibre optics evaluation kit, incorporating infra red transmitter, infra red receiver, 5 metres of terminated glass fibre lead and a comprehensive instruction booklet, is now available from Barlec Limited. Design

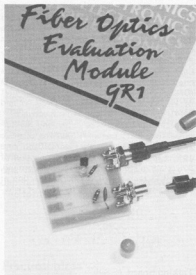

ated the GR1, the kit costs just £ 31.72, and needs only a 5 volt dc power supply to enable the user to transmit data at speeds up to 10 Mbits/second. The booklet not only provides working instruction, but a great deal of information on fibre optic principles and technology.

*Barlec Limited,
Foundry Lane,
Horsham,
West Sussex RH13 5PX,
Telephone: 0403.51881*

(2243 M)

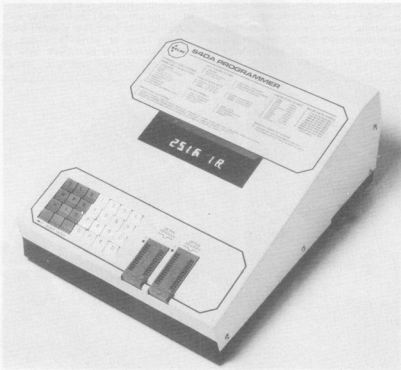

market

market

Temperature controller

The CAL 7200, two-term, proportional/derivative, electronic, temperature controller has a control accuracy of typically better than $\pm 0.5^\circ\text{C}$. Rapid warm-up and negligible overshoot of set temperature point are features. The front bezel measures only 48 x 96 mm. Temperature is set by means of a thumbwheel on the front panel. An analogue scale shows set point at a glance. To the left

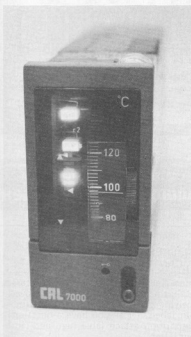

of the scale, a ten bar LED displays any deviation from set temperature point. Above this display, independent LEDs illuminate to show mains on/off and controller switching status. An internal 16 A 250 V AC switching relay is derated to 10 A to enhance switching life. A series of standard temperature ranges is available between 0 and 1600°C. A useful option is the solid state relay that employs opto-isolation techniques. It is protected, both internally and externally, for use with resistive and inductive loads.

Controls & Automation Ltd.,
Regal House,
55 Bancroft,
Hitchin,
Herts, SG5 1LL.

(2224 M)

available in an economical 'designer's kit' to facilitate engineering experimentation into the extended use of the system for science and industry. The kit contains a board similar to the one used in Polaroid's autofocus cameras, two wafer-thin Polapulse batteries, wiring assemblies, an LED (light emitting diode) readout and a technical manual.

Less than 4 cm in diameter, the electrostatic transducer is the key element in Polaroid's autofocus system. Distance is determined by electronically clocking the time required for high-frequency sound to travel from the transducer to an object and echo back to the transducer. The transducer consists of a thin gold-coated foil stretched over a concentrically-grooved aluminium plate. The foil is the moving element transforming electrical energy into sound waves and the returning echo into electrical energy.

The electronic circuitry supplied in the kit activates the transducer. The transducer then emits inaudible, high-frequency 'chirps' lasting only 1/1000 of a second at 60, 57, 53 and 50 kHz — the same frequencies used in Polaroid autofocus cameras. Included in the circuitry is a crystal oscillator clock which times the interval between sending and receiving, and an 'accumulator' which stores electronic pulses, translating time to distance. The entire 'electronic measurement' process takes only 1.5 milliseconds at a distance of 25 cm and 55 milliseconds at 9 m — accurate to within one percent.

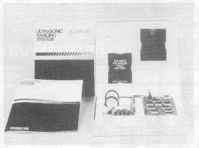

Polaroid's ultrasonic ranging system — pioneered for instant picture autofocus cameras — may easily be adapted or incorporated into areas where conventional measuring techniques are expensive, difficult, impractical or impossible; for instance, in fluid and bulk inventory control, in diagnostic medicine, machinery control, cybernetics, aviation and transportation. Early experiments have already resulted in prototypes of a 'touchless' cane for the blind, detecting distances and 'reporting' proximity to obstacles by varied frequency signals. The system may also be programmed as an 'electronic yardstick' to turn off machinery or vehicles when a distance is reached.

Business & Professional Publicity,
Polaroid (UK) Limited,
Ashley Road,
St. Albans,
Herts. AL1 5PR,
Telephone: St. Albans (0727) 59191

(2229 M)

Mobile CB antenna

With a height of 1.5 metres and an inductive matching unit at the base, the WHIPLASH totally conforms to the CB Licence requirements. In fact, this antenna was specifically designed to work efficiently over the legal 27 MHz frequency range. VSWR is a nominal 1.1 to 1 at band centre rising to no more than 1.5 to 1 at the band ends. Impedance is 50 ohms and power handling has been safety-tested up to 100 watts. The antenna is omnidirectional with vertical polarisation. The base internal winding is of large gauge double-enamelled wire. The base is fitted with the standard 3/8" screw fitting.

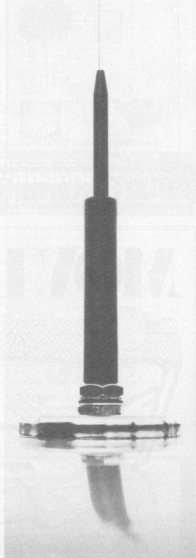

The WHIPLASH is now available from CB and electrical dealers nationally at about £ 11.95.
C. Brit Ltd,
Unit 3.5 Wembley Commercial Centre,
East Lane,
Wembley,
Midd. HA9 7XD.
Telephone: 01.908.2726

(2246 M)

Polaroid ultrasonic transducer

The electronics of Polaroid's unique ultrasonic automatic focusing system fitted to their Polasonic instant picture camera are now

market

WHO AND WHERE

A DIRECTORY OF ELECTRONIC COMPONENT SUPPLIERS TO ELEKTOR READERS
IF THERE IS A COMPONENT SHOP IN YOUR AREA NOT LISTED BELOW PLEASE LET US KNOW



AREA 1

AITKEN BROS. & CO.
35 High Bridge
Newcastle-upon-Tyne
NE1 1EW
Tel. 0632 26729

ALPHA SOUND SERVICES
50 Stuart Rd., Waterloo
Liverpool 22
Tel. 051 928 7862

N.R. BARDWELL LTD.
288 Abbeydale Road
Sheffield 7
Tel. Sheffield 52886

S. BELL TV SERVICES
190 Kings Road
Harrogate HG1 5JG
Tel. Harrogate 55885

CASEY BROTHERS
Palladium House
Boundary Road
St. Helens

Merseyside WA10 2LL
Tel. 0744 27873

DERWENT RADIO
5 Columbus Ravine
Scarborough, N. Yorkshire
Tel. 0732 63982

D.J.M.E.S. ELECTRONICS
Hobby Shop
1/3 Ellis Street
Peterhead
Grampian AB4 6JR
Tel. 0779 77515

ELECTRONIC ASSEMBLY SERVICES
Bright Street Works
Bury, Lancs. BL9 6AQ
Tel. 061 764 7634

ELECTROVALUE LTD.
680 Burnage Lane
Manchester M19 1NA
Tel. 061 432 4945

ELECTRO SUPPLIES
6A Todd Street
Manchester
Tel. 061 834 1185

GREENBANK ELECTRONICS
94 New Chester Road
New Ferry, Wirral
Merseyside L62 5AG
Tel. 051 645 3391

A. MARSHALL (London) LTD.
85 West Regent Street
Glasgow G2 2DD
Tel. 041 332 4133

PROGRESSIVE RADIO
93 Dale Street
Liverpool L2 2JD
Tel. 051 236 0982

SAPPHIRE ELECTRONICS
93 Domestic Street
Leeds LS11 9SG
Tel. Leeds 468017

SHUDEHILL SUPPLY CO. LTD
53 Shudehill
Manchester M4 4AW
Tel. 061 834 1449

SPECTRON ELECTRONICS
MANCHESTER LTD.
7 Oldfield Road
Greater Manchester
Tel. 061 834 4583

AREA 2

CARDIGAN ELECTRONICS
Chancery Lane
Cardigan
Dyfed
Tel. 0239 614483

CRYSTAL ELECTRONICS
40 Magdalene Road
Torquay, Devon
Tel. 22699

DURRANT RADIO
(COMPONENT SERVICE)
9 St. Mary's Street
Shrewsbury, Shropshire
Tel. 61239

G.M.T. ELECTRONICS
P.O. Box 290
8 Hampton Street
Birmingham B19 3JR
Tel. 021 233 2400

L.F. HANNEY
77 Lower Bristol Road
Bath BA2 3BS, Avon
Tel. 0225 24811

A. MARSHALL (London) LTD.
108A Stokes Croft
Bristol
Tel. 0272 426801

MONOLITH ELECTRONICS CO. LTD.
5/7 Church Street
Crewkerne
Somerset
Tel. 0460 74321

P.A.T.H. ELECTRONIC SERVICES
369 Alum Rock Road
Birmingham B8 3DR
Tel. 021 327 2339

RAMAR ELECTRONIC SERVICES LTD.
Masons Road
Stratford-on-Avon CV37 9NF
Tel. 4879

STEVE'S ELECTRONICS SUPPLY COMPANY
45 Castle Arcade
Cardiff CF1 2BU
Tel. 0222 41905

AREA 3

AMBIT INTERNATIONAL
200 North Service Road
Brentwood
Essex
Tel. 0277 230909
Telex 995194 Ambit G

ARROW ELECTRONICS
Coptfold Road
Brentwood
Essex
Tel. 0277 219435

AUDIO ELECTRONICS
301 Edgware Road
London W2 1BN
Tel. 01 724 3564

BI-PAK SEMICONDUCTORS
3 Baldoock Street
Ware, Herts.
Tel. 0920 61593

CAVERN ELECTRONICS
94 Stratford Road
Wolverton
Milton Keynes
Tel. Milton Keynes 314925

CHARLES TOWN
89 Carrington Street
Nottingham
Tel. 868933 & 55489

CHROMASONIC ELECTRONICS
56 Fortis Green Road
Muswell Hill
London N10 3HN
Tel. 01 883 3705/2289

CONTOUR ELECTRONICS
23 High Street
Stanstead Abbots
Ware, Herts.
Tel. 0279 415717

COSSOR ELECTRONICS
The Pinnacles
Elizabeth Way, Harlow
Essex CM19 5BB
Tel. 0279 28682

CRICKLEWOOD ELECTRONICS LTD.
40/42 Cricklewood Broadway
London NW2 3ET
Tel. 01 452 0161

C.T.S. LTD.
20 Chatham Street
Ramsgate
Kent CT11 7PP
Tel. Thanet 54072

D.P. HOBBS
11 King Street
Luton
Beds.
Tel. 0582 20907

ELECTROVALUE LTD.
28 St. Judes Road
Englefield Green
Egham
Surrey TW20 0HB
Tel. Egham 3603

ELEY ELECTRONICS
100/104 Beatrice Road
Leicester
Tel. 871522

J.T. FILMER
82 Dartford Road
Kent DA1 3ER
Tel. 0322 24057

FOREWAY SERVICES
19 Old High Street
Headington
Oxford
Tel. 0865

FRANK MOZER LTD.
5 Angel Corner Parade
Edmonton
London N18
Tel. 01 807 2784

G.B. GARLAND BROS. LTD.
Chesham House
Deptford Broadway
London SE8 4QN
Tel. 01 692 4412

GLOBAL SPECIALTIES CORP. (UK) LTD.
Shire Hill Industrial Estate
Saffron Walden
Essex CB11 3AQ
Tel. 0799 21682

GREENWELD ELECTRONICS
443E Milbrook Road
Southampton SO1 0HX
Tel. 0703 772501

HARRINGTON COLORVISION
9 Queen Street
Colchester
Essex
Tel. Colchester 47503

HENRY'S RADIO
404 Edgware Road
London W2
Tel. 01 723 5095

KAYS ELECTRONICS
195 Sheffield Road
Chesterville
Derbyshire
Tel. 0246 31696

MAPLIN ELECTRONIC SUPPLIES LTD.
P.O. Box 3
Rayleigh
Essex SS6 8LR
Tel. 0702 552911

Shops at:
159-161 King Street
Hammersmith
London W6
Tel. 01 748 0926
and
284 London Road
Westcliff-on-Sea
Essex
Tel. 0702 554000

A. MARSHALL (London) LTD.
325 Edgware Road
London W2
Tel. 01 723 4242

MAYDALE ELECTRONIC SERVICES
2 Wellesley Parade
Godstone Road
Whyteleafe
Surrey CR3 0BL
Tel. 08832 5169

MAYS OF CHURCH GATE
12/14 Church Gate
Leicester LE1 4AJ
Tel. 58662

NOBLE ELECTRONICS
26 Lloyd Street
Aldringham
Cheshire WA14 2DE
Tel. 061 941 4510

PHONOSONICS
22 High Street
Sidcup
Kent DA14 6EH
Tel. 01 302 6184

T. POWELL
Advance Works
44 Wallace Road
London N1
Tel. 01 226 1489

QC TRADING
21 Green Lanes
Palmer's Green
London N13 4TT
Tel. 01 889 7593

RB ELECTRICAL & ELECTRONICS
24 Springfield Park
Hollyport
Maidenhead
Berks.
Tel. 0628 39798

BRIAN J. REED
161 St. John's Hill
Battersea
London SW11
Tel. 01 223 5016

SERVIO RADIO LTD.
156 Merton Road
South Wimbledon
London SW19
Tel. 01 542 6525

SMITHS OF EDGWARE ROAD
287/289 Edgware Road
London W2 1BE
Tel. 01 723 5891

SWANLEY ELECTRONICS
P.O. Box 68
Swanley, Kent
Tel. 64851

TECHNOCRAFT
143 Tankerton Road
Whitstable, Kent
Tel. 0227 265097

TECHNOMATIC LTD.
17 Burnley Road
London NW10
Tel. 01 452 1500
Telex 922800

TK ELECTRONICS
11 Boston Road
London W7 3SJ
Tel. 01 579 9794

TRANSAM LTD.
59/61 Theobald's Road
London WC1
Tel. 01 405 5240/2113

VERO ELECTRONICS LTD.
Retail Dept.
Industrial Estate
Chandlers Ford
Hants. SO5 3ZR
Tel. Chandlers Ford 2956

AREA 4

CHIP ELECTRONIC SERVICES
37 Great William O'Brien Street
Cork
Ireland
Tel. 021 502428

THE ELECTRONIC CENTRE
16 College Square East
Belfast 1N
N. Ireland
Tel. Belfast 27357

WM. B. PEAT & CO. LTD.
25/26 Parnell Street
Dublin
Ireland
Tel. 749973/4

INTERNATIONAL

Australia Iceland

FRANK MATHIAS
715 George Street
(opp. Rawson Place)
Sydney 2000
Australia
Tel. 211-5003

SAMEIND HF
PO Box 7150
Grættisgata 46
127 Reykjavik
Iceland
Tel. 91-21366

Belgium

VADELEC ELECTRONICS
24 26 Avenue de l'Heleport
1000 Bruxelles
Tel. 02 218 26 40
Telex 26061

Denmark

DANSK MINI RADIO
Nr. Farimagsgade
57 59
1364 Copenhagen K

AAGE NIELSEN EFTF
1 Sortedam Dossingens
2200 Copenhagen

HOBBY ELECTRONICS
37 Nedergade
5000 Odense

**FREDERIKSHAVE HOBBY
ELEKTRONIK**
9 Havnegade
900 Frederikshavn

WK ELECTRONIC
6 Skoletorvet
8600 Silkeborg

HOLTE ELEKTRONIK
Holte Midpunkt
2840 Holte

LILLIE ELEKTRONIK
89 Sondergade
6500 Vejens

ROTEC
16 Jernbanegade
4800 Nykøbing Falster

Finland

AMERTRONICS OY
Vesijärvenkatu 33
SF-15140 Lahti 14
Finland

BEBEK ELECTRONIC KY
Rautatiénkatu 16
SF-15110 Lahti 11
Tel. 918-40666

BEBEK ELECTRONIC
Pui Jonkatu 26-28
SF-70100 Kuopio 10
Tel. 971-117667

METREX OY
PL 91
50101 Mikkeli 10
SF Finland

India

**PRECIOUS ELECTRONICS
CORPORATION**
3 Chunam Lane
Dadasaheb Bhadkamkar Marg
Bombay 400 007
Tel. 367459/369478
also at

9 Athipattan Street
Mount Road
Madras 600 002
Tel. 842718

RADIO & CRAFT PUBLICATIONS
376 Lajpat Rai Market
Delhi - 110006
Tel. 277147 / 224666

Indonesia

INEL CO
JL Veteran 71
Bandung
Indonesia

Israel

ZUR ELECTRONIC CENTER LTD.
1 Hagidim Street
Menora Square
Jerusalem

Italy

ELCOM
34170 Gorizia
Via Angiolina 23

Jordan

**GENERAL ELECTRONICS
CORP.**
United Insurance Building
King Hussein Street
P.O. Box 182099
Amman
Tel. 24347
Telex. 21262 NADERC — JO
Cable NADERCO Amman

Malaysia

DEVICE ELECTRONICS (PTE) LTD.
104 - 1st Floor
Singapore Electrical and
Electronics Hardware Centre
Maude Rd./Kitchener Rd.
Singapore 0820
Telex No. 33250

New Zealand

ORBIT ELECTRONICS
P.O. Box 7176
Auckland 1
New Zealand

Norway

ALFA ELEKTRONIKK
P.O. Box 118
N-4480 Kvinesdal

BLEKEN ELEKTRONIKK A/S
Raadyrvneien 32B
N-3160 Stokke
Tel. 033-36162

ELNOR
Haldensgt 5
7000 Trondheim

OSLO HOBBYSENTER A/S
Herslebsgt. 14-15
Oslo 5
Tel. (02) 679050

S. Africa

PHILTRON PTY. LTD.
P.O. Box 2749
Pretoria 0001

Sweden

COILTRONIC
Box 38
183 21 Taby
Tel. 08/768 32 61

DATA SELECT ELECTRONICS
Box 146
S-183 22 Taby
Tel. 46 762 514 16

INKO'X AB
Box 1057
721 27 Vasteras

KITEL DISTRIBUTION
Box 21149
S1 00 31 Stockholm

WHO
AND
WHERE

MAPLIN for ATARI

AUTHORISED DEALER



The World-beating ATARI PERSONAL COMPUTERS

3 consoles available

Atari 400 with 16K RAM (AF36P) £345

Atari 400 with 32K RAM (AF37S) £395

Atari 800 with 16K RAM (AFO2C) £645
(expandable to 48K)

All consoles when connected to a standard UK colour (or black and white) TV set can generate the most amazing graphics you've ever seen.

Look at what you get:

- * Background colour, plotting colour, text colour and border colour settable to any one of 16 colours with 8 levels of illumination!
- * Video display has upper and lower case characters with true descenders, double and quad size text and inverse video.
- * 57-Key keyboard (touch type on Atari 400) and four function keys.
- * Full screen editing and four-way cursor control.
- * 29 keystroke graphics and plottable points up to 320 x 192 (160 x 96 only with 8K RAM).
- * 40 character by 24 line display.
- * Extended graphics control and high speed action using a DMA chip with its own character set.
- * Player missile graphics.
- * Four programmable sound generators can be played individually or together and each has 1785 possible sounds playable at any one of eight volume settings, for game sounds or music.
- * Full software control of pitch, timbre and duration of notes in 4-octave range.
- * Four joystick or paddle ports, sounds output to TV.
- * BASIC cartridge and 10K ROM operating system and full documentation.



Atari 400 Console



Atari 800 Console

MORE HARDWARE

Atari 410 Cassette Recorder (AF28F)	£50
Atari 810 Disk Drive (AFD6G)	£345
Atari 822 40-column Thermal Printer (AFD4E)	£265
Atari 850 Interface (AF29G)	£135
Joystick Controllers (AC37S)	£13.95
Paddle Controllers (AC29G)	£13.95
16K RAM Memory Module (AF08L)	£65

MUCH MORE FOR ATARI COMING SOON

SOFTWARE

Lots and lots of amazing software for Atari available NOW

- ★ Word Processor ★ VISI-CALC
 - ★ ADVENTURE GAMES ★ Arcade Games
 - ★ Trek Games ★ ASSEMBLER & DISASSEMBLER ★ FORTH ★ Teaching
 - ★ 3D GRAPHICS ★ Character Set Generator
- SEND S.A.E. NOW FOR OUR LEAFLET (XH52G)

LE STICK

For Atari Computer or Video Game
Replaces standard joystick, but much easier to use. Internal motion detectors sense hand movements. Large pushbutton on top of Stick. Squeeze Stick to freeze motion. A MUST for SPACE INVADERS, STAR RAIDERS & ASTEROIDS.
ONLY £24.95 (AC45Y)

SPECIAL PACKAGE OFFER

Disk-based system for £725 with Le Stick
The Atari 400 Console
Special 32K RAM Module
Atari 810 Disk Drive
Disk Operating System
Documentation
Interconnecting Leads

Everything in "Look at what you get" list.

Can any other computer on the market offer all this at anything like this price?

VERSAWRITER

12½ x 8in. drawing board. Drawing on board is reproduced on TV via Atari with 32K RAM and Disk Drive. Closed areas may be filled in with one of 3 colours. Text may be added in any one of 4 fonts. Paint brush mode: select size of brush and paint away. Air brush mode: shade in your drawing - colour and density is up to you. Plus many more features. S.a.e. for price and further details.

Demonstrations at our shops NOW
See Atari at 284 London Road, Westcliff-on-Sea, Essex.
Tel: (0702) 554000 and at 159-161 King St., Hammersmith W6.
Tel: 01-748 0926

MAPLIN

Maplin Electronic Supplies Ltd
P.O. Box 3, Rayleigh, Essex.
Tel: Southend (0702) 552911/554155

Note: Order codes shown in brackets.
Prices firm until 14th November, 1981
and include VAT and Postage and Packing.
(Errors excluded).