

nr. 43  
november 1978

U.K. 50p.  
U.S.A. | Can. \$1.50

# elektor

up-to-date electronics for lab and leisure

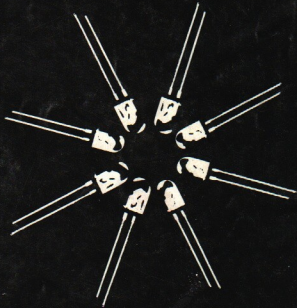
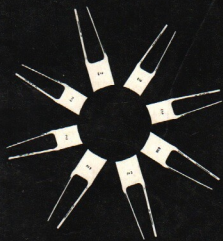
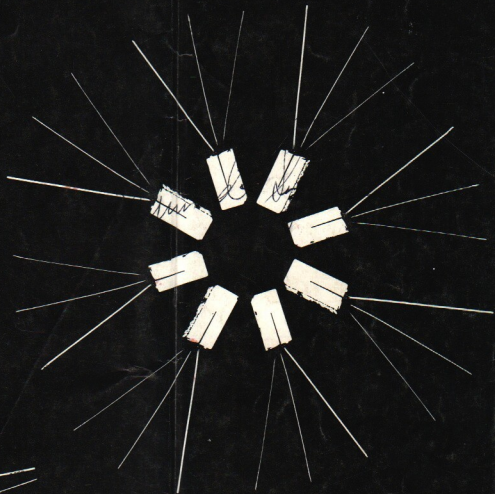

Austria S. 33  
Belgium F. 55  
Denmark Kr. 9

France F. 7  
Germany DM. 3.80  
Netherlands DFL. 3.25

Norway Kr. 9  
Sweden Kr. 9  
Switzerland F. 4.40





COMPUTERS LTD  
Electronic Components Division

22 Newland Street Kettering Northants.  
Technical enquires ring Kett 520910 sales & order enquires 83922.  
Shop open Monday to Saturday 9.30 to 6.00 p.m. Early closing Thursday.  
Answer phone order service after 6.00 p.m. 83922  
Back issues of Elekter & Elekter Boards normally available from stock.  
Quantity and trade enquires welcomed for all components.  
Quantity and trade enquires welcomed for all components.

A Member Firm of the Brikat Developments (Holdings) Group

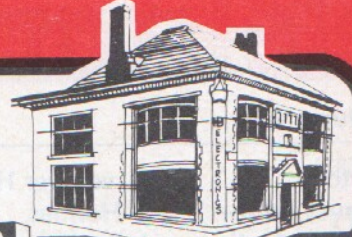

IC's

PRICE REDUCTIONS

Table listing various ICs such as CA3080 OTA, CA3084 decoder, CA3090A decoder, CA3130T opamp, CA3140T FET opamp, etc. with prices.

Table listing various ICs such as RM18129 ultra sonic transceiver, LM1899 VHS Mod, LM3908 quad Norton amp, etc. with prices.

Table titled 'LOW COST CMOS' listing various CMOS ICs like 4000, 4001, 4002, 4006, etc. with prices.

EXPERIMENTING WITH SC/MP

BUILD YOUR OWN MICROPROCESSOR DEVELOPMENT SYSTEM

The current Elekter series leads to the construction of a hexadecimal seven segment microcomputer with a cassette interface. Further development is planned, to produce a private computer system with visual display unit, cassette based programmes and an extended memory capacity.  
To enable you to reduce your costs we are preparing a kit order list for each part of the series to enable you to order just those parts you need and not to duplicate components you already have.  
Please send SAE for lists or phone Kettering 520910 for further details about the series.

Table listing components for the SC/MP system, including HB Announce new lower prices on many products, and a list of components like BC107/8/9, BC547/8/9, etc.

74 SERIES TTL

Table listing 74 Series TTL components such as 7400 12 7416 28, 7401 12 7417 28, 7402 14 7420 15, etc.

HARDWARE & EQUIPMENT

Table listing hardware and equipment items like Edge connectors 31 way (SC/MP), SWITCHES, ANTEX SOLDERING IRONS, etc.

CATALOGUE '78

Catalogue 78 available now.  
A must for serious constructors. Contains details of many unusual and difficult to obtain components for Elekter projects plus pages and pages of data information pin outs etc.  
Normal price 75p but as special introductory offer for Elekter readers for limited period 50p plus 18p P & P

CAPACITORS

Table listing various capacitors including MKM Metallised Polycarbonate, CERAMIC, and ELECTROLYTIC CAPACITORS.

CRYSTALS, FILTERS & INDUCTORS

Table listing crystals, filters, and inductors like 32.768 kHz KDT 3.30 CERAMIC, 32.768 kHz MTQ 32 12 6.00 FILTERS, etc.

TRANSISTORS & DIODES

Table listing various transistors and diodes such as BC107 10, BC108 10, BC109 10, BC140 42, etc.

Visit our new computer showroom. Where our sister company, HB computers will be demonstrating the PET 2001, now in stock.

MICROPROCESSORS & PERIF

Table listing microprocessors and peripherals like Micro's and Memories, 1103A-2, CDP1802 MPU, etc.

OPTOELECTRONICS

Table listing optoelectronics components like Display drive, DL704 CC RDP 0.3", DL707 CA LDP 0.3", etc.

ORDERING DETAILS

DISCOUNT: Mail order customers deduct 10% on orders over £20.00.  
VAT add high rate to items, standard rate to others.  
POST & PACKING 50p on orders under £7.50.  
Otherwise free. Overseas please add freight costs and state surface or Air DELIVERY. All orders processed on day of receipt.  
All goods offered subject to availability and our conditions of sale.  
PAYMENT: Cash, cheque or postal order with order.  
Access, Mastercard, Bank American visa or Barclaycard number by phone or letter for orders over £2.  
Official orders from Government bodies, accepted, but minimum invoice charge £2.  
GUARANTEE: All devices are brand new and full spec, unless otherwise stated. Any faulty item returned in good condition within fourteen days will be exchanged or refunded.  
BACK COPIES: Elekter and Elekter EPS circuit boards available at published prices.  
PRICES valid at the time of going to press.  
ENQUIRIES: Please enclose suitable s.a.w. E & O.E.



## elektor

## 43 decoder

Volume 4

Number 11

Editor : W. van der Horst  
 Deputy editor : P. Holmes  
 Technical editors : J. Barendrecht, G.H.K. Dam,  
 E. Krempelsauer, G.H. Nachbar  
 A. Nachtmann, K.S.M. Walraven  
 Subscriptions : Mrs. A. van Meyel

International head offices: Elektor Publishers Ltd.  
 Bourgognestr. 13a  
 Beek (L), Netherlands  
 Tel. 04402-4200  
 Telex: 56617 Elekt NL

U.K. editorial offices, administration and advertising:  
 Elektor Publishers Ltd., Elektor House,  
 10 Longport Street, Canterbury CT1 1PE, Kent. U.K.  
 Tel.: Canterbury (0227)54430. Telex: 965504.  
 Please make all cheques payable to Elektor Publishers Ltd.  
 at the above address.

Bank: 1. Midland Bank Ltd., Canterbury, A/C no. 11014587  
 Sorting code 40-16-11, Giro no. 3154254.  
 2. U.S.A. only: Bank of America, c/o World Way  
 Postal Center, P.O. Box 80689, Los Angeles,  
 CA 90080, A/C no. 12350-04207.  
 3. Canada only: The Royal Bank of Canada,  
 c/o Lockbox 1969, Postal Station A, Toronto,  
 Ontario, M5W 1W9. A/C no. 160-269-7.

Assistant Manager : R.G. Knapp  
 Advertising Manager : N.M. Willis

ELEKTOR IS PUBLISHED MONTHLY on the third Friday of each month.

- U.K. and all countries except the U.S.A. and Canada:  
 Cover price £ 0.50.  
 Number 39/40 (July/August), is a double issue, price £ 1.—.  
 Subscriptions for 1978, January to December incl.,  
 £ 6.75 (surface mail) or £ 12.00 (air mail).
- For the U.S.A. and Canada:  
 Cover price \$ 1.50.  
 Number 39/40 (July/August), is a double issue, price \$ 3.—.  
 Subscriptions for 1978, January to December incl.,  
 \$ 18.— (surface mail) or \$ 27.— (air mail).  
 All prices include post & packing.

CHANGE OF ADDRESS. Please allow at least six weeks for change of address. Include your old address, enclosing, if possible, an address label from a recent issue.

LETTERS SHOULD BE ADDRESSED TO the department concerned:  
 TQ = Technical Queries; ADV = Advertisements; SUB = Subscriptions;  
 ADM = Administration; ED = Editorial (articles submitted for  
 publication etc.); EPS = Elektor printed circuit board service.

For technical queries, please enclose a stamped, addressed envelope or a self-addressed envelope plus an IRC.

THE CIRCUITS PUBLISHED ARE FOR domestic use only. The submission of designs or articles to Elektor implies permission to the publishers to alter and translate the text and design, and to use the contents in other Elektor publications and activities. The publishers cannot guarantee to return any material submitted to them. All drawings, photographs, printed circuit boards and articles published in Elektor are copyright and may not be reproduced or imitated in whole or part without prior written permission of the publishers.

PATENT PROTECTION MAY EXIST in respect of circuits, devices, components etc. described in this magazine. The publishers do not accept responsibility for failing to identify such patent or other protection.

National ADVERTISING RATES for the English-language edition of Elektor and/or international advertising rates for advertising at the same time in the English, Dutch and German issues are available on request.

DISTRIBUTION in U.K.:  
 Seymour Press Ltd., 334 Brixton Road, London SW9 7AG.

DISTRIBUTION in CANADA: Gordon and Gotch (Can.) Ltd.,  
 55 York Street, Toronto, Ontario, M5J 1S4.

Copyright © 1978 Elektor publishers Ltd — Canterbury.

Printed in the UK by Thanet press.



MEMBER OF THE AUDIT  
 BUREAU OF CIRCULATIONS

What is a TUN?  
 What is 10 n?  
 What is the EPS service?  
 What is the TQ service?  
 What is a missing link?

## Semiconductor types

Very often, a large number of equivalent semiconductors exist with different type numbers. For this reason, 'abbreviated' type numbers are used in Elektor wherever possible:

- '741' stand for  $\mu$ A741, LM741, MC641, MIC741, RM741, SN72741, etc.
- 'TUP' or 'TUN' (Transistor, Universal, PNP or NPN respectively) stand for any low frequency silicon transistor that meets the following specifications:

UCEO, max	20V
IC, max	100 mA
hfe, min	100
Ptot, max	100 mW
fT, min	100 MHz

Some 'TUN's are: BC107, BC108 and BC109 families; 2N3856A, 2N3859, 2N3860, 2N3904, 2N3947, 2N4124. Some 'TUP's are: BC177 and BC178 families; BC179 family with the possible exception of BC159 and BC179; 2N2412, 2N3251, 2N3906, 2N4126, 2N4291.

- 'DUS' or 'DUG' (Diode Universal, Silicon or Germanium respectively) stands for any diode that meets the following specifications:

	DUS	DUG
UR, max	25V	20V
IF, max	100mA	35mA
IR, max	1 $\mu$ A	100 $\mu$ A
Ptot, max	250mW	250mW
CD, max	5pF	10pF

Some 'DUS's are: BA127, BA217, BA218, BA221, BA222, BA317, BA318, BAX13, BAY61, 1N914, 1N4148.

Some 'DUG's are: OA85, OA91, OA95, AA116.

- 'BC107B', 'BC237B', 'BC547B' all refer to the same 'family' of almost identical better-quality silicon transistors. In general, any other member of the same family can be used instead.

## BC107 (-8, -9) families:

BC107 (-8, -9), BC147 (-8, -9), BC207 (-8, -9), BC237 (-8, -9), BC317 (-8, -9), BC347 (-8, -9), BC547 (-8, -9), BC171 (-2, -3), BC182 (-3, -4), BC382 (-3, -4), BC437 (-8, -9), BC414

## BC177 (-8, -9) families:

BC177 (-8, -9), BC157 (-8, -9), BC204 (-5, -6), BC307 (-8, -9), BC320 (-1, -2), BC350 (-1, -2), BC557 (-8, -9), BC251 (-2, -3), BC212 (-3, -4), BC512 (-3, -4), BC261 (-2, -3), BC416.

## Resistor and capacitor values

When giving component values, decimal points and large numbers

of zeros are avoided wherever possible. The decimal point is usually replaced by one of the following abbreviations:

p (pico-) =  $10^{-12}$   
 n (nano-) =  $10^{-9}$   
 $\mu$  (micro-) =  $10^{-6}$   
 m (milli-) =  $10^{-3}$   
 k (kilo-) =  $10^3$   
 M (mega-) =  $10^6$   
 G (giga-) =  $10^9$

A few examples:

Resistance value 2k7: 2700  $\Omega$ .  
 Resistance value 470: 470  $\Omega$ .  
 Capacitance value 4p7: 4.7 pF, or 0.000 000 004 7 F...  
 Capacitance value 10n: this is the international way of writing 10,000 pF or .01  $\mu$ F, since 1 n is  $10^{-9}$  farads or 1000 pF.  
 Resistors are  $\frac{1}{4}$  Watt 5% carbon types, unless otherwise specified. The DC working voltage of capacitors (other than electrolytics) is normally assumed to be at least 60 V. As a rule of thumb, a safe value is usually approximately twice the DC supply voltage.

## Test voltages

The DC test voltages shown are measured with a 20 k $\Omega$ /V instrument, unless otherwise specified.

## U, not V

The international letter symbol 'U' for voltage is often used instead of the ambiguous 'V'. 'V' is normally reserved for 'volts'. For instance:  $U_b = 10$  V, not  $V_b = 10$  V.

## Mains voltages

No mains (power line) voltages are listed in Elektor circuits. It is assumed that our readers know what voltage is standard in their part of the world! Readers in countries that use 60 Hz should note that Elektor circuits are designed for 50 Hz operation. This will not normally be a problem; however, in cases where the mains frequency is used for synchronisation some modification may be required.

## Technical services to readers

• **EPS service.** Many Elektor articles include a lay-out for a printed circuit board. Some — but not all — of these boards are available ready-etched and predrilled. The 'EPS print service list' in the current issue always gives a complete list of available boards.

• **Technical queries.** Letters with technical queries should be addressed to: Dept. TQ. Please enclose a stamped, self addressed envelope; readers outside U.K. please enclose an IRC instead of stamps.

• **Missing link.** Any important modifications to, additions to, improvements on or corrections in Elektor circuits are generally listed under the heading 'Missing Link' at the earliest opportunity.





After several experiments, one of our designers succeeded in imitating the sound of a self satisfied hen — using a single CMOS IC. A simple timer completes the cackling egg-timer.

p. 11-02



The most common method of communicating with a micro-computer is via an alpha-numeric keyboard. The ASCII keyboard is principally intended for use with the 'Elekterminal', which will be described next month, however the standard design ensures that it can also be employed with other data terminals.

p. 11-06

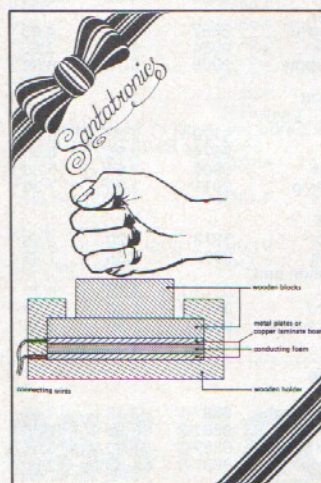

One of the favourite attractions at fair-grounds has always been some variation of 'ring the bell and win a prize'. Originally, this was a purely mechanical device. However, electronics have now progressed to the point where a portable version is possible — suitable for desk-top use.

p. 11-22

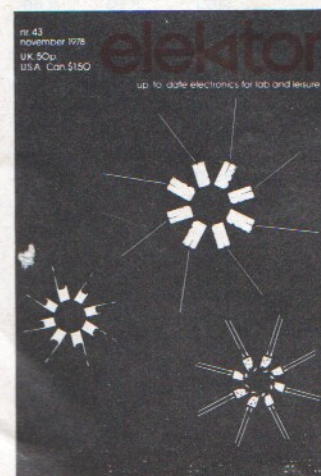

In this issue, several 'Santatronics' circuits are described: little projects that should prove suitable as Christmas gifts. November may seem rather soon for this, but the idea is to allow time for neat construction and 'gift-wrapping'! As to the cover, 'Santatronics' is associated both with electronics and with 'Dashing through the snow' . . .

# contents

selektor .....	UK-16
cackling egg-timer .....	11-02
ASCII keyboard .....	11-06
Tag! .....	11-12
This strenuous game can now be played without physical effort.	
joysticks — G. Wunsch .....	11-16
Joystick-type controls are becoming as popular in the electronic game field as they have always been for remote control of model aircraft and boats. Provided the appearance isn't considered too important, it is quite feasible to construct a joystick control that will be quite suitable for most applications.	
digiscope — E. Müller .....	11-17
For examining pulse trains in digital circuits an oscilloscope is an invaluable aid. However, oscilloscopes are expensive, and furthermore the analogue display capability of a conventional 'scope is rarely required in digital circuits. The Digiscope offers a low-cost alternative.	
ring the bell and win a prize .....	11-22
extending the TV scope .....	11-25
As explained last month, a normal TV set can be used as an oscilloscope. A simple converter for this purpose was described in detail: the 'TV scope-basic version'. In an introductory article it was explained that this basic version could be extended. Before discussing the details of the extension circuits, a fuller explanation of the underlying principles is in order.	
15 duty-cycles at the turn of a switch .....	11-30
hello, all you folks back home! .....	11-31
Instead of gathering around the fire as in the 'good old days', we tend to gather around the telephone. The circuit described will pick up the telephone conversation and reproduce it via a loudspeaker, so that several people can listen in.	
applikator .....	11-34
R.P.M. and dwell meter using a TCA 965.	
SC/MP 'Mastermind'™ programme .....	11-35
F. Schuldt Pit your wits against the computer with the aid of the 'Mastermind'™ programme, which is designed to run on the Elektor SC/MP system.	
pocket bagatelle .....	11-38
There are many electronic versions of popular games which can be played without recourse to a TV set. One of the more simple (but not necessarily easy!) games, which is ideally suited as a small Christmas present, is 'bagatelle'.	
market .....	11-41
advertiser's index .....	UK-28

## COMING SOON

In response to readers queries, the additional circuits required to extend the range of the electronic piano (Elektor, September 1978) to eight octaves (!) will be described next month.





# cackling egg-timer

Boiling eggs is one of the more delicate of culinary occupations, especially since the ideal consistency of a boiled egg can be the subject of quite heated discussions: the hard-boiled spurn soft hearts, and the difference is a matter of minutes. It is not surprising, therefore, that some fertile brain in the distant past came up with that highly practical invention: the egg-timer.

Of recent years, electronics engineers have devoted a surprising amount of their time, ingenuity and eggspertise into the quest for an electronic version, and circuits are published at regular intervals. However, to the best of our knowledge, the circuit presented here is the first to cackle loudly when the timing period has elapsed!

Electronics is invading the most unlikely fields. After several experiments, with sometimes highly comical results, a member of the Elektor design team has even succeeded in imitating the sound of a self-satisfied hen — using a single CMOS IC. A simple timer, consisting of two further ICs, completes the novel egg-timer.

The block diagram is shown in figure 1. The timer section is fairly conventional. A decade counter receives pulses from a clock generator. Since the period time of the clock generator is 1 minute, the decade counter effectively counts minutes. The counter is started by pressing the 'reset' button. When the time selected by the multi-position switch has elapsed, two things happen: the clock generator is blocked, stopping the count, and the electronic switch (S) is

closed. This switch applies power to the second part of the circuit, enclosed in dotted lines: the 'cackle circuit' that imitates the smugly complacent hen. This circuit consists of three square-wave generators, two of which are voltage-controlled (the VCOs).

The three generators are labelled according to the frequency they produce: 'L' for low, 'M' for mid-range and 'H' for high frequency — relatively, of course. The audio signal is derived from the third VCO ('H'). The other VCO, 'M', provides the basic modulation required for the 'bock-bock-bock' effect. The first generator adds two further effects: the repetition rate of the cackling and the duration of each cycle. These two effects, combined, also determine the number of clucks-per-cycle.

If one considers the characteristic

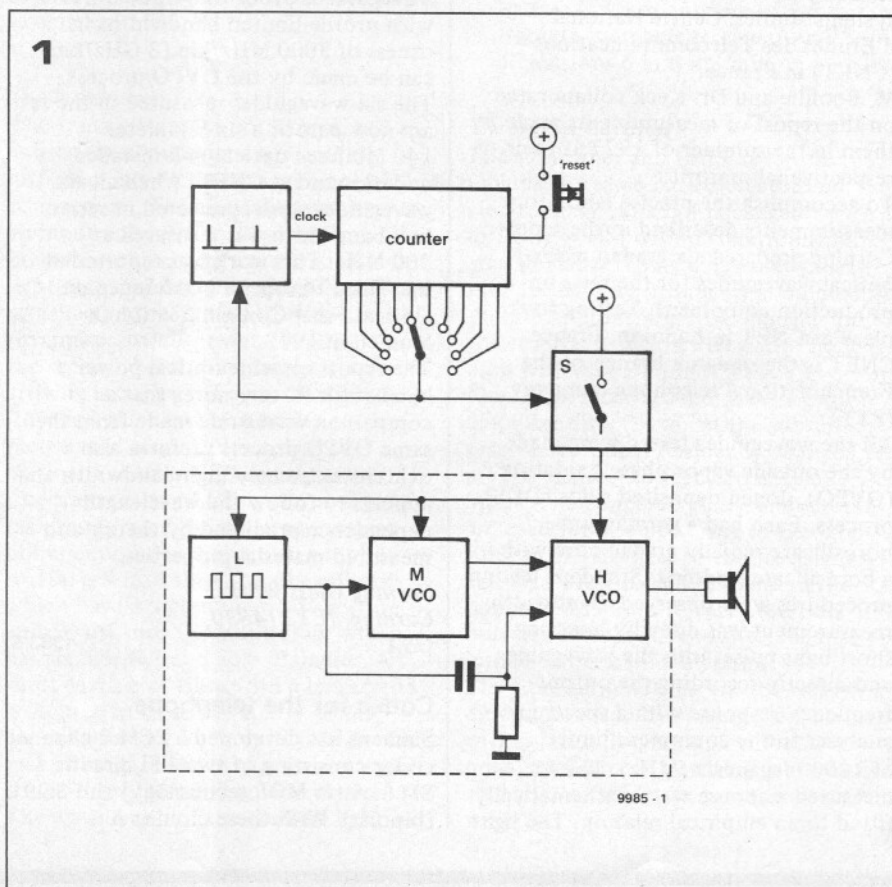

Figure 1. Block diagram of the cackling egg-timer. The section enclosed in dotted lines is the 'cackle generator'.

Figure 2. Output waveforms from the three oscillators in the cackle generator.

Figure 3. The complete circuit. The upper portion is the timer; the lower section is the cackle generator.



2

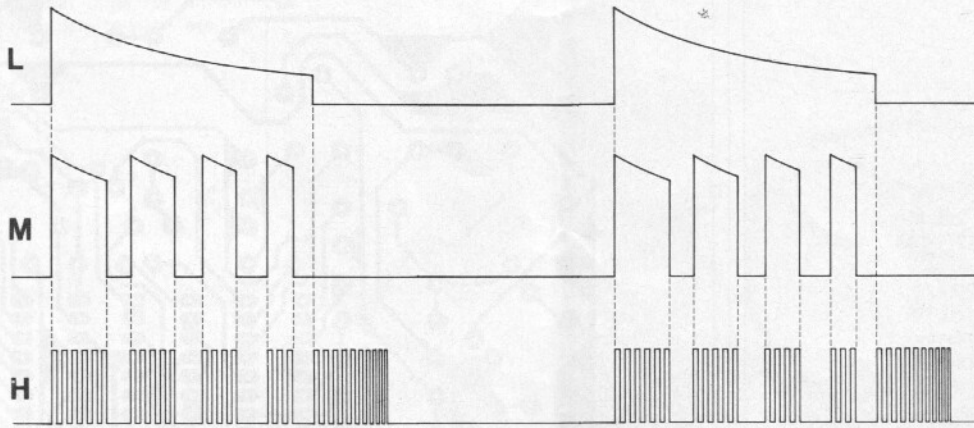

9985 - 2

3

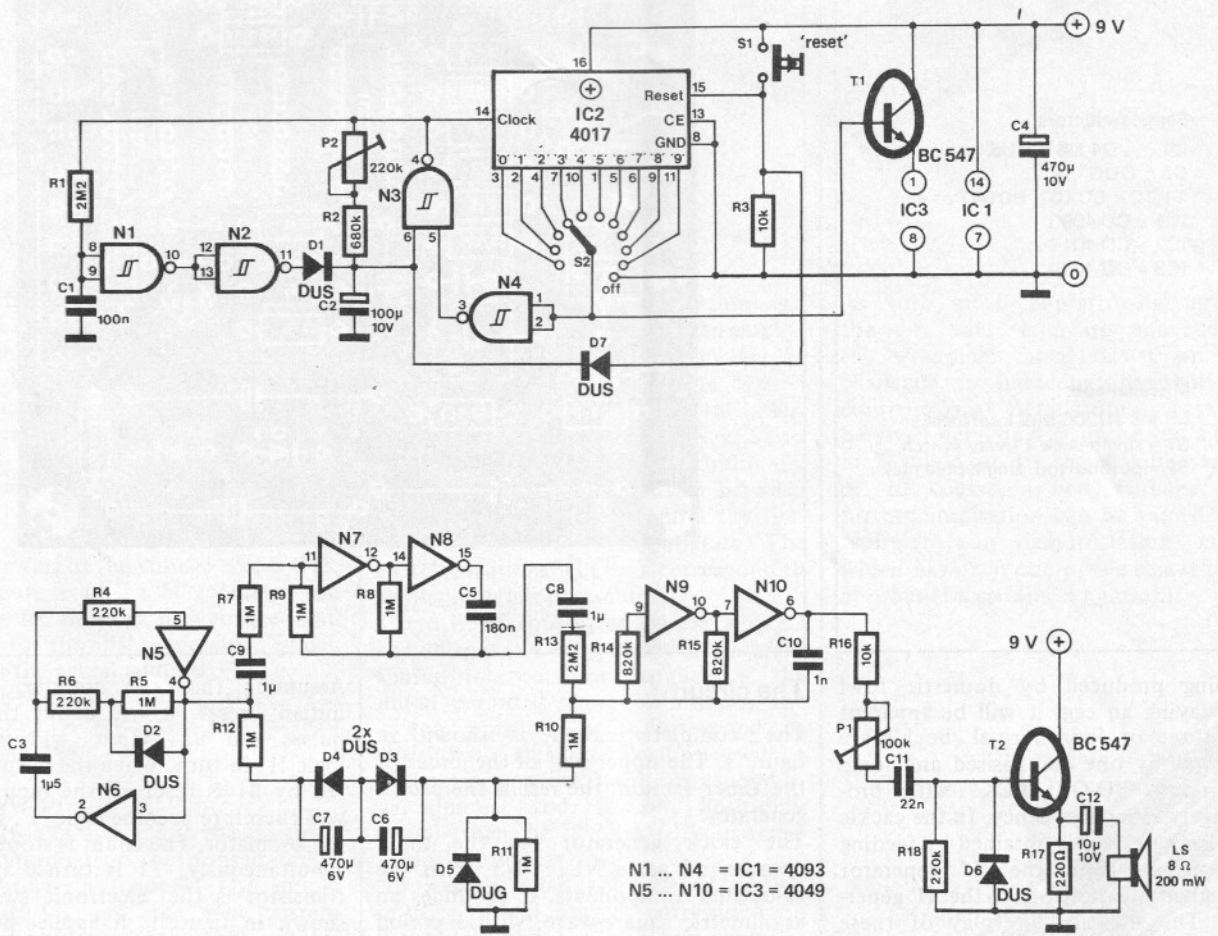

9985 - 3



## Parts list

## Resistors:

R1 = 100 k  
 R2 = 680 k  
 R3, R16 = 10 k  
 R4, R6, R18 = 220 k  
 R5, R7 . . . R12 = 1 M  
 R13 = 2M2  
 R14, R15 = 820 k  
 R17 = 220  $\Omega$   
 P1 = 100 k, preset  
 P2 = 220 k, preset

## Capacitors:

C1 = 10 n  
 C2 = 100  $\mu$ /10 V  
 C3 = 1  $\mu$ 5  
 C4 = 470  $\mu$ /10 V  
 C5 = 180 n  
 C6, C7 = 470  $\mu$ /6 V  
 C8, C9 = 1  $\mu$   
 C10 = 1 n  
 C11 = 22 n  
 C12 = 10  $\mu$ /10 V

## Semiconductors:

D1 . . . D4, D6 = DUS  
 D5 = DUG  
 T1, T2 = BC 107, BC 547 or equ.  
 IC1 = CD 4093  
 IC2 = CD 4017  
 IC3 = CD 4049

## Miscellaneous:

LS = 8  $\Omega$ /200 mW loudspeaker  
 S1 = single-deck 11-way switch  
 S2 = pushbutton, single-pole make

4

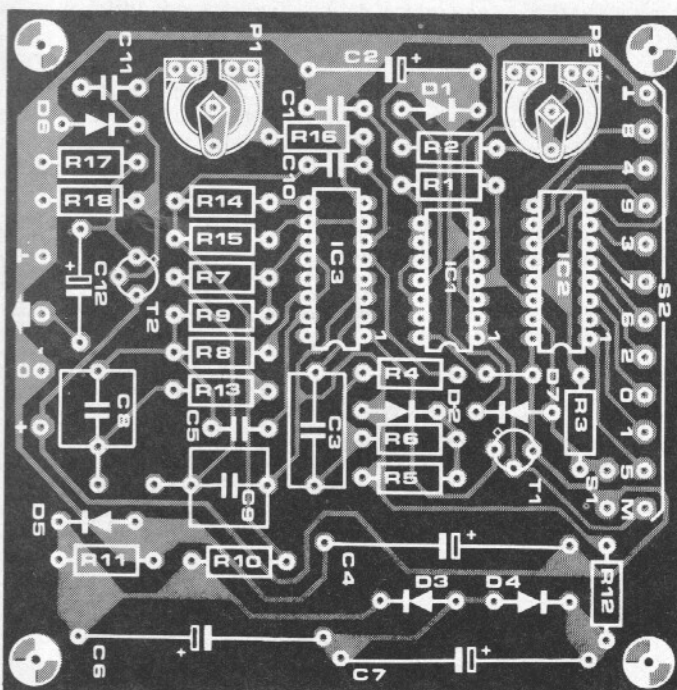
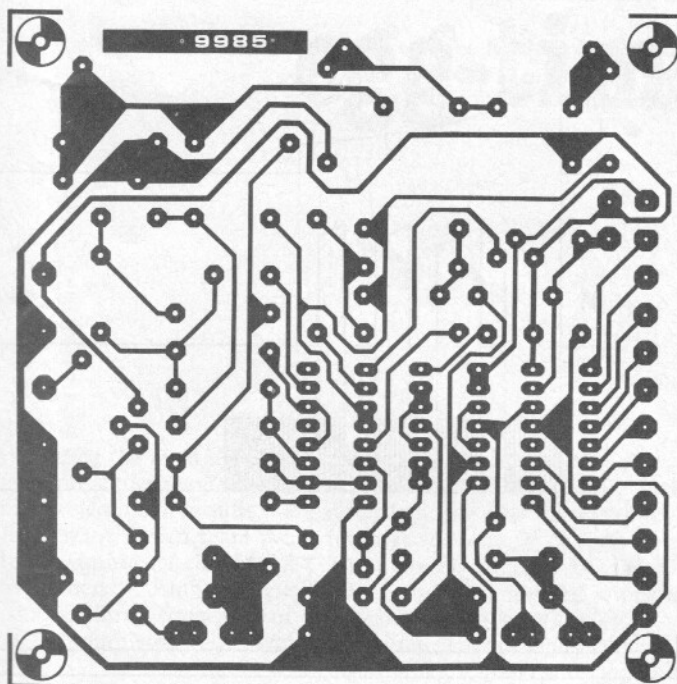

cackling produced by domestic fowl after laying an egg, it will be apparent that three or four normal 'bock's are followed by one emphasised and long-drawn-out 'BO-O-O-CK' with progressively rising frequency. In the cackle circuit, this effect is obtained by feeding the output from the 'L' generator through an RC-network to the 'H' generator. The delicate interplay of these three generators provides a surprisingly realistic imitation of a proud mother hen. Figure 2 illustrates the signals at various points in the cackle generator.

## The circuit

The complete circuit is shown in figure 3. The upper half of the circuit is the timer section; the rest is the cackle generator.

The clock generator for the timer consists of gates N1 . . . N3, with the associated components. It produces an asymmetric square-wave, with a period time (set by P2) of 1 minute. This oscillator can only produce an output signal when the output of N4 is at logic '1', i.e. when the input to N4 is logic '0'.

Assuming that the counter, IC2, is initially reset, it will count the clock pulses and its outputs will swing to logic '1' in turn. When the output selected by S1 is reached, the input to N4 will therefore become logic '1', stopping the oscillator. The count is stopped and, simultaneously, T1 is turned on. This transistor is the 'electronic switch', S, shown in figure 1: it applies power to IC3 in the cackle generator, causing the hen to give voice.

The lower half of the circuit, the cackle generator, may appear rather confusing



Figure 4. Printed circuit board and component layout for the cackling egg-timer (EPS 9985).

Figure 5. When it comes to 'Santatronics', the gift-wrapping is almost as important as the contents. The demonstration model shown here is perhaps somewhat large for normal domestic use, but it may help to stimulate the imagination.

at first sight. Reference to the block diagram may help to clarify matters. The free-running generator 'L' consists of N5 and N6; the 'M' and 'H' VCOs are similar circuits using N7/N8 and N9/N10, respectively.

A diode, D2, is included in the 'L' generator to obtain an asymmetrical output signal. This signal is fed, via C9 and R7, to the 'M' VCO. The output from the 'M' VCO now contains most of the information required for the 'bock-bock-bo-o-o-ock' effect. As illustrated in figure 2, the number and length of the 'bock's, the breathing space and the (rising) frequency shift are all determined, with one exception: the modulation for the final, long-drawn-out 'b-o-o-o-ck'. This signal is derived from the output of the 'L' generator via an RC network consisting of R10, R11, R12, C6, C7 and three diodes. Capacitors C6 and C7 and diodes D3 and D4 together are basically equivalent to a bipolar electrolytic. D5 limits the negative swing of the voltage across R11. The outputs from the 'M' generator and from the RC network are summed and applied to the 'H' generator, which produces the actual audio signal.

A single-transistor buffer stage, T2, drives the loudspeaker. The desired volume can be set with P1.

### Construction

The electronics involved in the egg-timer can be mounted on the printed circuit board shown in figure 4. The supply voltage (9 V) and the low current consumption make the circuit suitable for battery operation. If a mains supply is used, due care must be taken to reliably insulate the complete unit: it will



be used in decidedly damp surroundings, quite possibly beside the kitchen sink! There are only two adjustments. As mentioned earlier, P1 sets the desired volume. P2 is used to calibrate the timer. The easiest way to do this is to set S1 to position '1' and adjust P2 until the timing interval (i.e. the time between pressing the reset button and the first squawk) is exactly one minute. The switch positions will then correspond to timing intervals in minutes.

There is, of course, no reason why P2 should not be set to give a different timing interval. For instance, if the initial period is set at 1½ minutes, the switch positions will correspond to multiples of this time. Position 2 will be 3 minutes, position 3 will correspond to 4½ minutes, and so on. Position 9 would then be  $9 \times 1\frac{1}{2} = 13\frac{1}{2}$  minutes — ideal for 'bullet'-lovers.

No matter what the setting of P2, position 0 will always correspond to 0 minutes: the hen will give voice as soon as the reset button is operated. This option is included mainly for demonstration purposes.

As with most 'Santatronics' circuits, the 'gift' value is greatly enhanced by the wrapping. Since this is an ideal challenge to individual creativity, no constructional details for a case will be given here. Just a suggestion: a novel idea would be to shape it like an egg or, of course, a hen. Perhaps some further inspiration can be gained from figure 5: our demonstration model, which has been one of the center-pieces at otherwise serious exhibitions! **K**

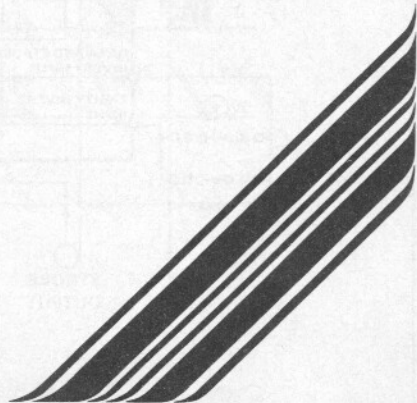



# ASCII keyboard

The most common method of communicating with a microcomputer is via an alphanumeric keyboard. The keyboard assembly described here is principally intended for use with the 'Elekterminal', which will be described next month, however the standard design ensures that it can also be employed with other data terminals.

As its name suggests, an alphanumeric keyboard is one which contains both alphabetic characters and (decimal) numerals as well as the usual punctuation marks. Obviously, for the computer and data terminal to be able to 'understand' one another, they have to speak the same language, and to this end, several standard formats have been devised, which allocate a particular binary code to each alphanumeric character. The most popular and widely-used format is the American Standard Code for Information Interchange, usually referred to by its acronym, ASCII. This is an 8-bit code, in which

the most significant bit (MSB) is used as a parity bit for error detection. Since 7 binary digits can be arranged in 128 different combinations, it is clear that a considerable number of the 7-bit codes are left over once all the decimal digits, alphabetic characters and punctuation symbols have been catered for. In the ASCII format the remaining codes are assigned control functions. A complete listing of the ASCII character set, with an explanation of the control characters, is shown in table 1.

### Keyboard circuit

Although, in principle, it would be

1a

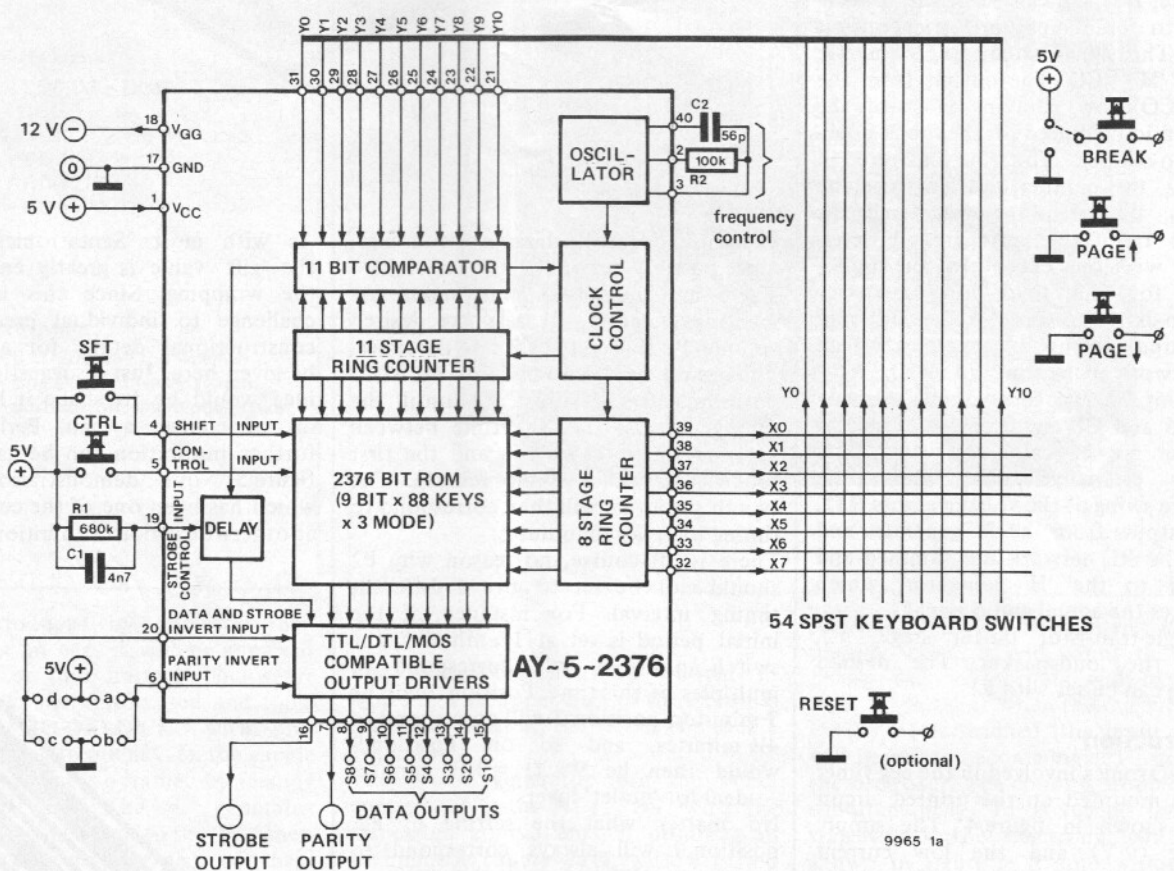



1b

### AY-5-2376

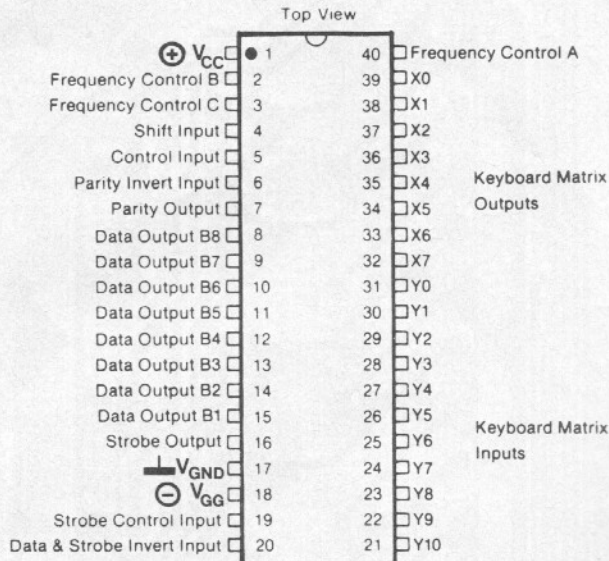

9965 - 1b

Figure 1. Pin configuration and block diagram of the AY-5-2376 amount to a circuit diagram of the keyboard.

Figure 2. This figure illustrates which elements of the matrix are occupied by keys.

2

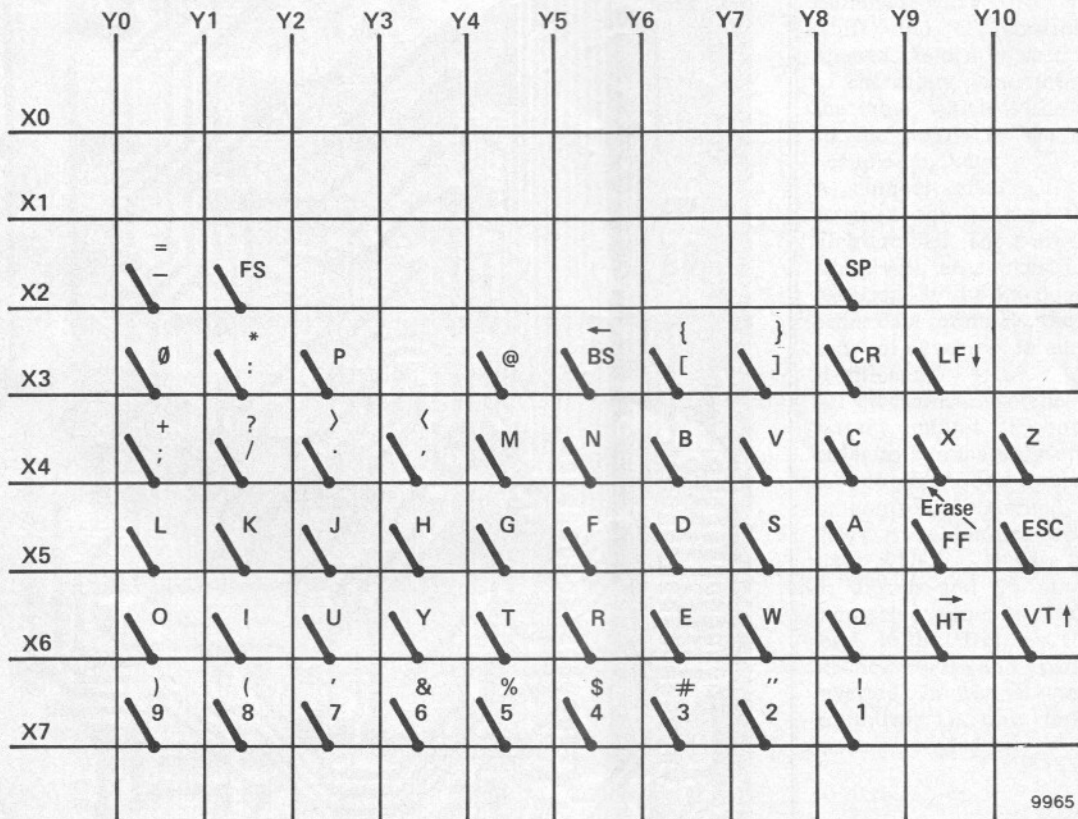

9965 2



parts list to figures 1, 3 and 4

Resistors:

R1 = 100 k  
R2 = 680 k

Capacitors:

C1 = 4n7  
C2 = 56 p

Semiconductors:

IC1 = AY-5-2376 (General Instru-  
ments)

Miscellaneous:

62 keyboard switches: TKC  
type MM9 — 2

*We have been informed that the TKC switches are to be supplied in the UK by the following companies (see advertisement section for further details): Astec Europe Ltd., Windsor De Boer Electronics, Eindhoven Marshall's Ltd., London*

Figure 3. Track pattern of the keyboard p.c.b. (EPS 9965).

Figure 4. Component overlay of the keyboard p.c.b.

*Note that the copper layout and component overlay are reproduced here at 90% of actual size.*

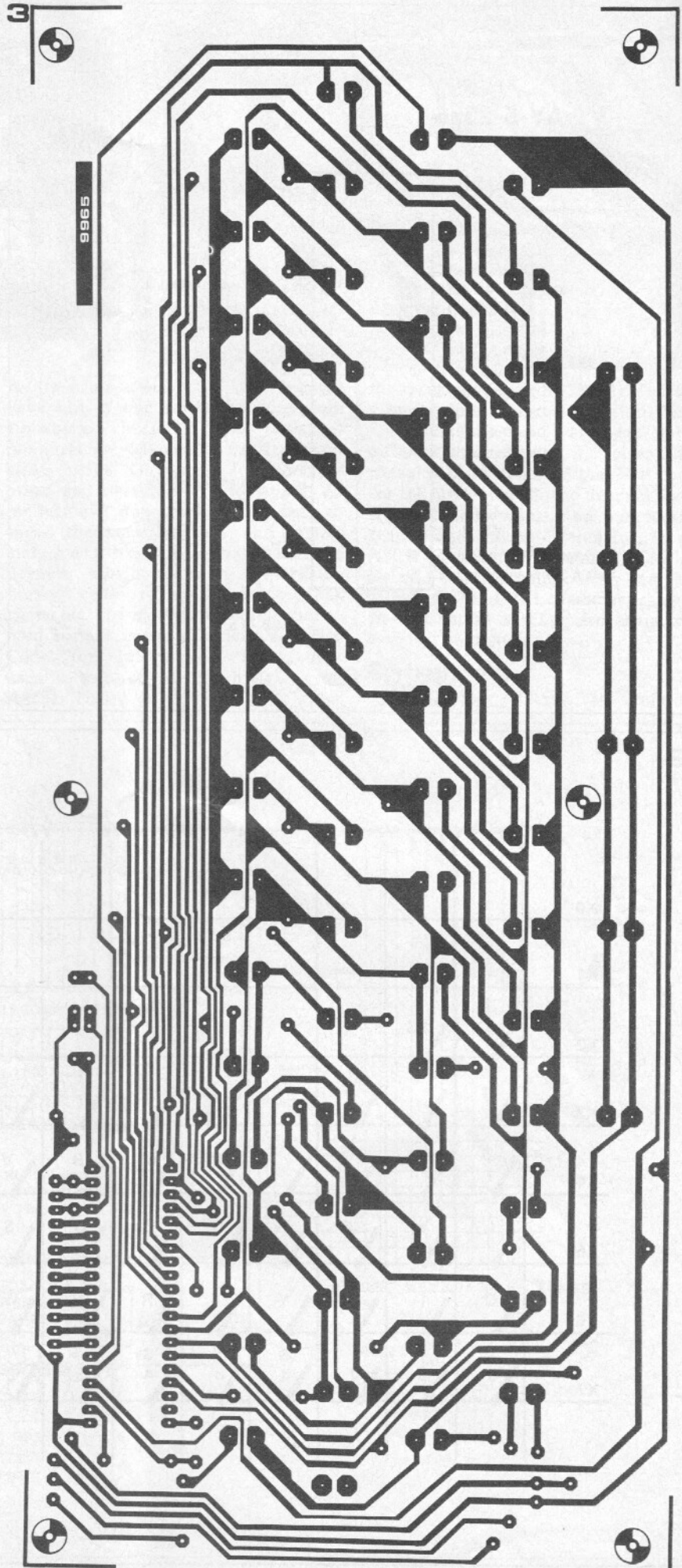



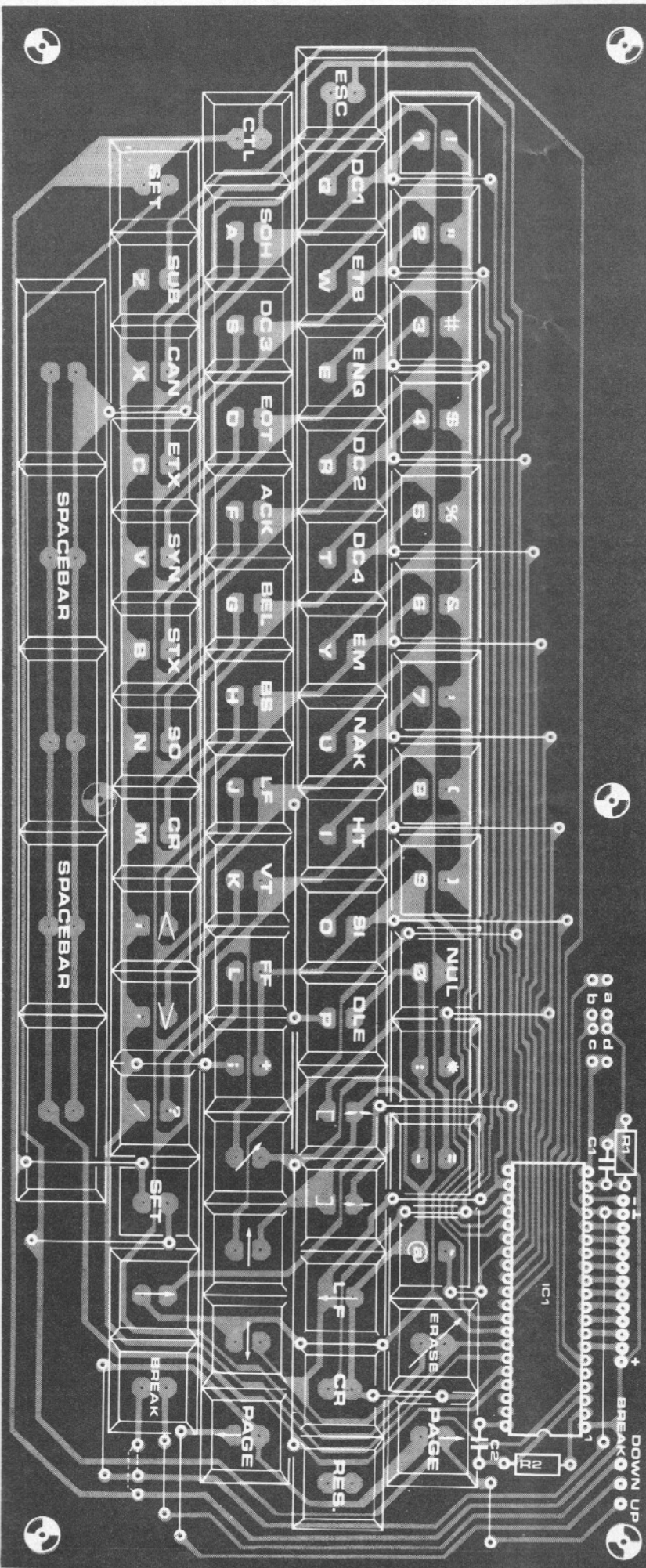

possible to design a keyboard which had a separate key for each of the 128 characters, it would obviously be not only extremely expensive, but rather unwieldy. Thus, as is the case with typewriters, each key is normally assigned a double (or triple) function, with a shift key to determine which of the codes which correspond to a particular key is in fact generated.

The key closures are converted into ASCII code by means of an encoder IC; this is basically little more than a ROM in which the complete ASCII code is stored, and which is addressed by the keyboard. There are several IC encoders currently available, the one used here is the AY-5-2376 from General Instruments. Pin-out details and internal block diagram of the IC - which constitutes virtually the entire circuit diagram of the keyboard - are shown in figure 1.

In order to keep the wiring of the keyboard as simple as possible, the keys are arranged in a matrix as shown in figure 2. For reasons which will become clear, not every point in the matrix requires a key. In addition to those keys in the matrix, several additional keys are shown in figure 1, namely a break key, two page keys, a reset key, a shift key and a control key. The break- and page keys are intended for the Elekterminal (to be described next month), whilst the reset key is optional. The shift- and control keys are used to select the different functions of each key in the keyboard matrix. This is illustrated in table 2, which lists the characters obtained when the 'N' (normal), 'S' (shift) and 'C' (control) keys are depressed. As can be seen, a large number of characters occur more than once in the table, which is the reason why not all the points in the matrix need be occupied by keys.

A number of ASCII characters are assigned non-standard functions in the Elekterminal. These are listed in table 3, along with an explanation of their new function. If the keyboard is used with other data terminals, then the characters can, of course, retain their original significance.

All mechanical switches are prone to a certain amount of contact bounce. In order to eliminate the effects of this the IC contains a delay network which can be controlled externally. The length of delay is determined by the time constant R1/C1. Via wire links a, b, c and d, pins 6 and 20 of the IC can be connected either to a '0' or '1' voltage level. In the latter case, the data outputs, strobe-output and parity output are inverted. In normal use these pins are grounded, i.e. only links c and b are made.

**Construction**

In order to facilitate construction of the keyboard a printed circuit board was designed, which is intended to accomo-



Table 1.

Character	Binary Bit 7 to Bit 0	Hexadecimal	Character	Binary Bit 7 to Bit 0	Hexadecimal
NUL	00000000	00	@	01000000	40
SOH	00000001	01	A	01000001	41
STX	00000010	02	B	01000010	42
ETX	00000011	03	C	01000011	43
EOT	00000100	04	D	01000100	44
ENQ	00000101	05	E	01000101	45
ACK	00000110	06	F	01000110	46
BEL	00000111	07	G	01000111	47
BS	00001000	08	H	01001000	48
HT	00001001	09	I	01001001	49
LF	00001010	0A	J	01001010	4A
VT	00001011	0B	K	01001011	4B
FF	00001100	0C	L	01001100	4C
CR	00001101	0D	M	01001101	4D
SO	00001110	0E	N	01001110	4E
SI	00001111	0F	O	01001111	4F
DLE	00010000	10	P	01010000	50
DC1	00010001	11	Q	01010001	51
DC2	00010010	12	R	01010010	52
DC3	00010011	13	S	01010011	53
DC4	00010100	14	T	01010100	54
NAK	00010101	15	U	01010101	55
SYN	00010110	16	V	01010110	56
ETB	00010111	17	W	01010111	57
CAN	00011000	18	X	01011000	58
EM	00011001	19	Y	01011001	59
SUB	00011010	1A	Z	01011010	5A
ESC	00011011	1B	[	01011011	5B
FS	00011100	1C	\	01011100	5C
GS	00011101	1D	]	01011101	5D
RS	00011110	1E	^	01011110	5E
US	00011111	1F	_	01011111	5F
SP	00100000	20	`	01100000	60
!	00100001	21	a	01100001	61
"	00100010	22	b	01100010	62
#	00100011	23	c	01100011	63
\$	00100100	24	d	01100100	64
%	00100101	25	e	01100101	65
&	00100110	26	f	01100110	66
'	00100111	27	g	01100111	67
(	00101000	28	h	01101000	68
)	00101001	29	i	01101001	69
*	00101010	2A	j	01101010	6A
+	00101011	2B	k	01101011	6B
,	00101100	2C	l	01101100	6C
-	00101101	2D	m	01101101	6D
.	00101110	2E	n	01101110	6E
/	00101111	2F	o	01101111	6F
0	00110000	30	p	01110000	70
1	00110001	31	q	01110001	71
2	00110010	32	r	01110010	72
3	00110011	33	s	01110011	73
4	00110100	34	t	01110100	74
5	00110101	35	u	01110101	75
6	00110110	36	v	01110110	76
7	00110111	37	w	01110111	77
8	00111000	38	x	01111000	78
9	00111001	39	y	01111001	79
:	00111010	3A	z	01111010	7A
:	00111011	3B	{	01111011	7B
<	00111100	3C		01111100	7C
=	00111101	3D	}	01111101	7D
>	00111110	3E	~	01111110	7E
?	00111111	3F	DEL	01111111	7F

- NUL — null, or all zeros
- SOH — start of heading
- STX — start of text
- ETX — end of text
- EOT — end of transmission
- ENQ — enquiry
- ACK — acknowledge
- BEL — bell
- BS — backspace
- HT — horizontal tabulation
- LF — line feed
- VT — vertical tabulation
- FF — form feed
- CR — carriage return
- SO — shift out
- SI — shift in
- DLE — data link escape
- DC1 — device control 1
- DC2 — device control 2
- DC3 — device control 3
- DC4 — device control 4
- NAK — negative acknowledge
- SYN — synchronous idle
- ETB — end of transmission block
- CAN — cancel
- EM — end of medium
- SUB — substitute
- ESC — escape
- FS — file separator
- GS — group separator
- RS — record separator
- US — unit separator
- SP — space
- DEL — delete

Table 1. This table lists the complete ASCII character set, along with the corresponding binary and hexadecimal values for each character.

Table 2. This table illustrates the relationship between the keyboard matrix and the corresponding set of characters. It is apparent that, since several characters appear more than once, a key is not required for every element of the matrix.

Table 3. A number of ASCII characters are assigned non-standard functions in the Elektor terminal. This table indicates which characters are involved and also their new significance.

Figure 5. Keyboard layout.



Table 2.

	C: control	S: shift	N: normal	y 0	y 1	y 2	y 3	y 4	y 5	y 6	y 7	y 8	y 9	y 10
x 0	C			NUL	SOH	STX	ETX	EOT	ENQ	ACK	BEL	DC1	DLE	SI
	S			NUL	SOH	STX	ETX	EOT	ENQ	ACK	BEL	DC1	@	←
	N			NUL	SOH	STX	ETX	EOT	ENQ	ACK	BEL	DC1	P	O
x 1	C			DLE	VT	FF	SO	CR	NAK	SYN	ETB	CAN	EM	SUB
	S			DLE	[	\	↑	]	NAK	SYN	ETB	CAN	EM	SUB
	N			DLE	K	L	N	M	NAK	SYN	ETB	CAN	EM	SUB
x 2	C				FS	GS	RS	US				SP		US
	S			=	FS	GS	RS	US	<	>	,	SP	.	←
	N			-	FS	GS	RS	US	<	>	,	SP	.	←
x 3	C				DLE	US		BS	ESC	GS	CR	LF		RUB
	S			*	P	DEL	'	BS	{	}	CR	LF		OUT
	N			0	:	p	←	@	BS	[	]	CR	LF	
x 4	C						CR	SO	STX	SYN	ETX	CAN		SUB
	S			+	?	>	<	M	N	B	V	C	X	Z
	N			:	/	.	,	m	n	b	v	c	x	z
x 5	C			FF	VT	LF	BS	BEL	ACK	EOT	DC3	SOH	FF	ESC
	S			L	K	J	H	G	F	D	S	A	FF	ESC
	N			l	k	j	h	g	f	d	s	a	FF	ESC
x 6	C			SI	HT	NAK	EM	DC4	DC2	ENQ	ETB	DC1	HT	VT
	S			O	I	U	Y	T	R	E	W	Q	HT	VT
	N			o	i	u	y	t	r	e	w	q	HT	VT
x 7	C												RS	FS
	S			)	(	'	&	%	\$	=	"	!	ESC	
	N			9	8	7	6	5	4	3	2	1	↑	\

date all the necessary hardware (i.e. including the keys). Figures 3 and 4 show the copper track pattern and component overlay respectively. The board layout is designed to take TKC type MM9 keyboard switches. The keyboard layout is illustrated in figure 5. A certain amount of care should be used when mounting the keys. Since they are only held in place by their terminal pins one must be careful to ensure that the keys are correctly positioned, otherwise there is the danger that the key tops may touch one another and a key will remain depressed after being hit. The best solution is to mount the keys row by row, using a jig or template to hold the keys in place.

The connections between the keyboard and receiver section of the terminal are best made using ribbon cable, via which the keyboard can simultaneously be provided with the necessary supply voltages of +5 and -12 V. The current consumption of both supplies is a maximum of 10 mA.

Table 3.

CTL	+	L	=	FF	(FORM FEED)	=	home cursor + page clear
CTL	+	J	=	LF	(LINE FEED)	=	LF + cursor ↓
CTL	+	I	=	HT	(HORIZONTAL TAB)	=	cursor →
CTL	+	K	=	VT	(VERTICAL TAB)	=	cursor ↑
CTL	+	M	=	CR	(CARRIAGE RETURN)	=	CR = erasure to end of line
CTL	+	H	=	BS	(BACK SPACE)	=	cursor ←
CTL	+	\	=	FS	(FILE SEPARATOR)	=	home cursor
SFT	+	↑	=	ESC	(ESCAPE)	=	scroll up
CTL	+	Z				=	erasure of current line

5

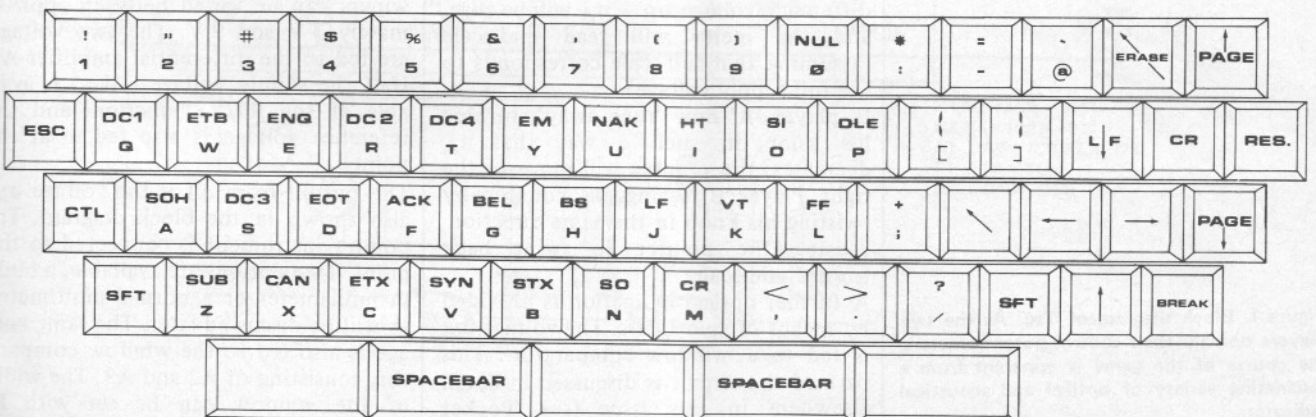



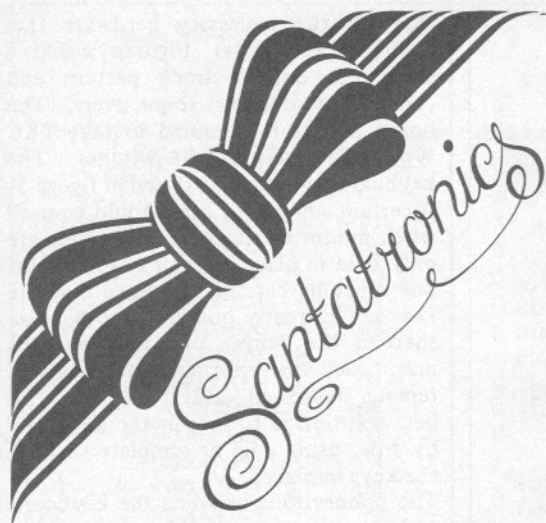

One of the simpler games known to man is 'Tag'. Variations of the game were probably played by cave-men. There are very few rules: it is simply a question of one person being 'him' or 'it', and running around trying to 'catch' or 'tag' the other player(s). What the game lacks in sophistication, it makes up for in sheer physical strenuousness. In its basic form it is not really a parlour game, either; the risk of toppling tables, falling flowers and the cat in the curtains is more than most parents are prepared to take. Since the main characteristics of the coming months are snow, sleet and Santa Claus, a safe, indoor version of the game should prove welcome.

Figure 1. Block diagram of Tag. As the two players operate their control potentiometers, the course of the game is apparent from a fascinating variety of optical and acoustical indicators.

Figure 2. The complete circuit.

Instead of running like mad, the two players of the electronic version of tag merely twist the knob of a potentiometer madly to and fro. The rules are as simple as in the original game: player 'A' attempts to manipulate his knob in such a way that the pointer of a multimeter moves out of a small area around mid-scale; player 'B' does his utmost with *his* knob to keep the pointer within the area. In other words, player 'A' tries to 'run away', and player 'B' tries to catch him. If 'B' is successful, in that he succeeds in tracking 'A' for a sufficient length of time, a LED lights to indicate that 'B' has 'caught' his opponent.

To increase the effect, sound effects are included: the player controls also sweep two oscillators up and down. The outputs from these oscillators can be fed to the two channels of a stereo amplifier, producing penetrating wails that sweep up and down through the audio range.

The block diagram (figure 1) illustrates the basic principles involved. The control potentiometers 'A' and 'B' provide voltages  $u_A$  and  $u_B$ . The difference voltage  $u_B - u_A$  is determined, and added to half the supply voltage  $U_b$ . The result is a voltage  $u_M$  which swings to and fro around  $\frac{1}{2}U_b$ , depending on the values of  $u_A$  and  $u_B$ . This voltage is displayed on the multimeter. Obviously, if the two potentiometers are in the same position the difference voltage  $u_B - u_A$  will be zero, and the meter will read mid-scale (assuming that full-scale corresponds to the full supply voltage).

If player 'A' now 'runs away', turning his knob in such a way that  $u_A$  decreases, the pointer will move to the right. Player 'B', seeing this, counters by twisting his knob in the same direction, causing the pointer to swing back toward mid-scale.

A further optical indication is provided by means of two LEDs. The voltage  $u_M$  is fed to a 'window comparator'. This part of the circuit is discussed in detail elsewhere in this issue (see 'Pocket Bagatelle'). For the present application it is sufficient to know that the

output voltage  $u_C$  from the window comparator is logic zero as long as the input voltage  $u_M$  remains within the voltage 'window', and becomes logic 'one' as soon as  $u_M$  is outside the 'window'. In other words, since the voltage window is a small range around half supply voltage,  $u_C$  is logic zero as long as the pointer reads approximately mid-scale, and becomes logic 1 if the pointer moves out of this area. As soon as this happens, a LED lights ('escaped'). If player 'A' succeeds in catching 'B' again, the LED will extinguish. If 'A' can now 'hold on to' player 'B' for a sufficient length of time (determined by an RC-network) a different LED will light: 'Gotcha!'

The two VCO's are driven direct from the player control voltages,  $u_A$  and  $u_B$ . If the outputs from these oscillators are fed to the two channels of a stereo amplifier, an audible indication is obtained of the positions of the two controls. If 'A' has caught 'B' — in other words, if the control voltages are equal — the tones produced by the two VCO's will also be (almost) the same.

### The circuit

Having understood the basic principles, the circuit itself (figure 2) is fairly straightforward. P1 and P2 are the player controls. The voltages at the wipers can be varied between approximately 3 V and 9 V. The two voltages are fed to the differential amplifier A1. Half the supply voltage ( $\frac{1}{2}U_b$ ) is available at the R7/R8 junction, and this reference voltage is also fed in at this point.

The output from A1 is the voltage  $u_M$ , also shown in the block diagram. The pointer instrument is connected to this point. Two options are available, a built-in millimeter or a normal multimeter, as will be discussed later. The same voltage is also fed to the window comparator, consisting of A2 and A3. The width of the window can be set with P3 ('handicap'). Obviously, a wide window makes it easier to catch the opponent,

# Tag!

a strenuous game  
can be played  
without physical effort



1

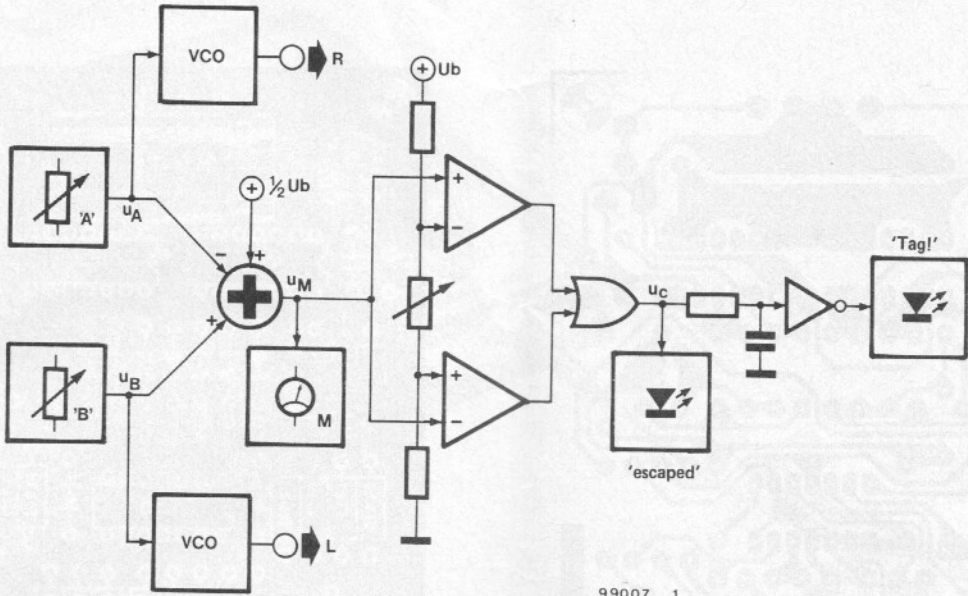

99007 1

2

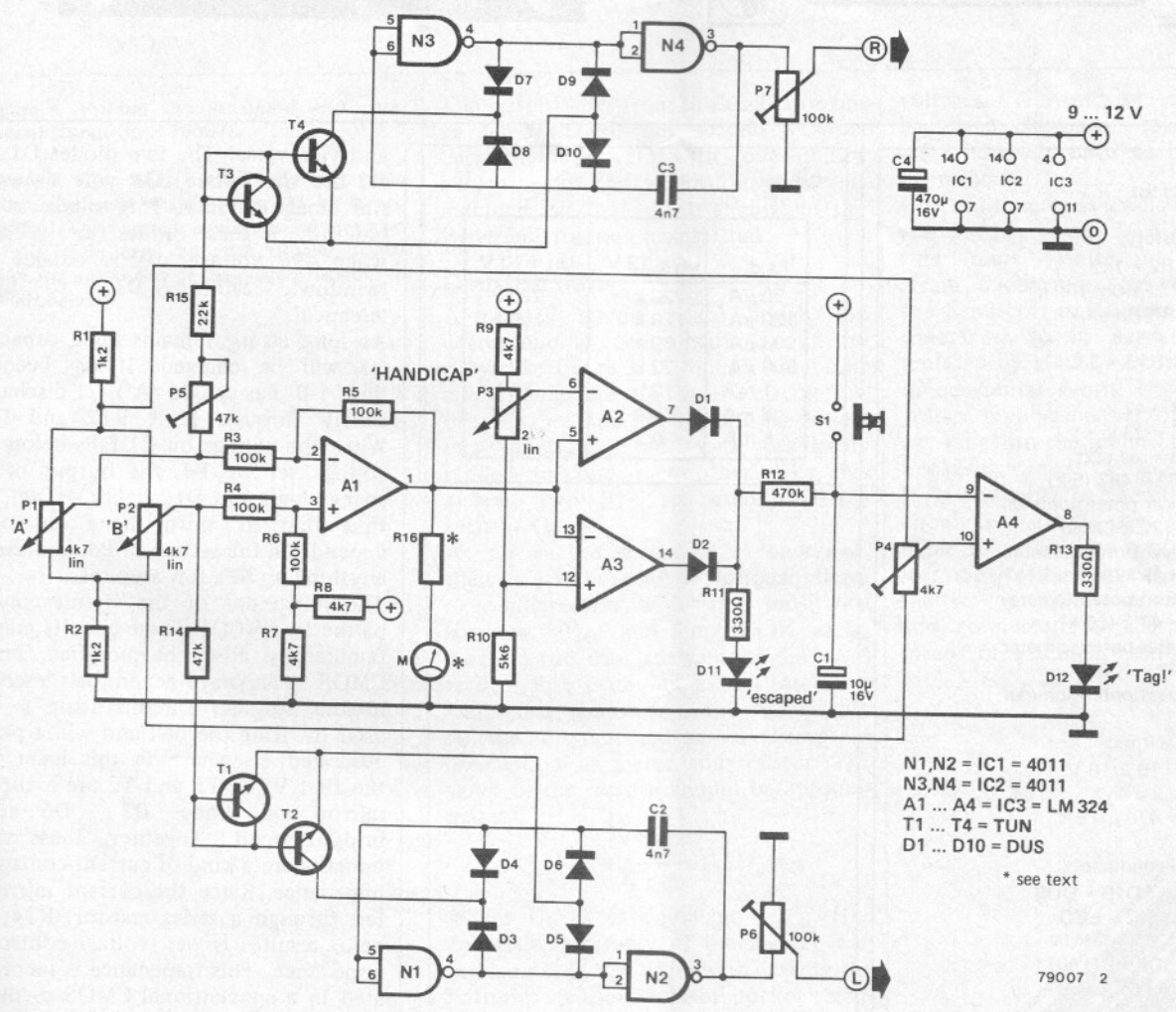

N1,N2 = IC1 = 4011  
 N3,N4 = IC2 = 4011  
 A1 ... A4 = IC3 = LM 324  
 T1 ... T4 = TUN  
 D1 ... D10 = DUS  
 \* see text

79007 2



3

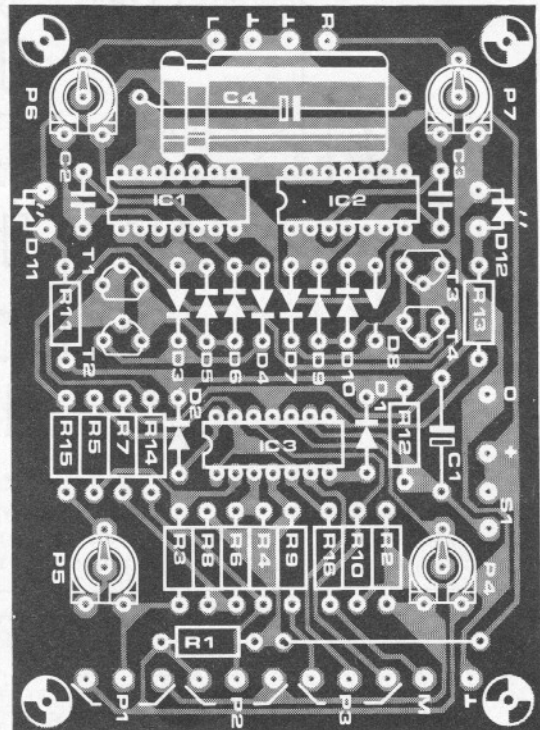
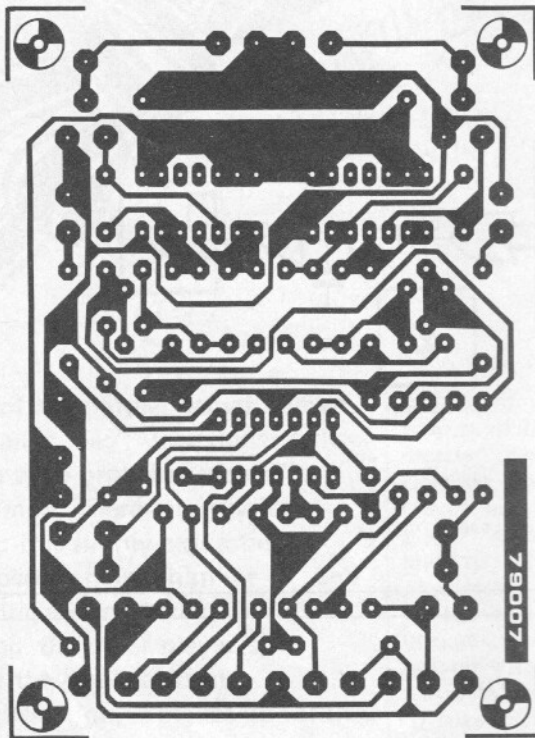

#### Parts list

##### Resistors:

R1,R2 = 1k2  
 R3...R6 = 100 k  
 R7,R8,R9 = 4k7  
 R10 = 5k6  
 R11,R13 = 330  $\Omega$   
 R12 = 470 k  
 R14 = 47 k  
 R15 = 22 k  
 R16 = see text  
 P1,P2 = 4k7 (5 k)  
   linear potentiometer  
 P3 = 22 k (25 k)  
   linear potentiometer  
 P4 = 4k7 (5 k)  
   preset potentiometer  
 P5 = 47 k (50 k)  
   preset potentiometer  
 P6,P7 = 100 k  
   preset potentiometer

##### Capacitors:

C1 = 10  $\mu$ /16 V  
 C2,C3 = 4n7  
 C4 = 470  $\mu$ /16 V

##### Semiconductors:

D1...D10 = DUS  
 D11,D12 = LED  
 T1...T4 = TUN  
 IC1,IC2 = CD 4011  
 IC3 = LM 324

##### Miscellaneous:

S1 = pushbutton, single-pole,  
   make  
 M = meter, see text

Table

I <sub>f,s.d.</sub>	R16	
	U <sub>b</sub> = 12 V	U <sub>b</sub> = 10 V
50 $\mu$ A	220 k	220 k
100 $\mu$ A	120 k	100 k
300 $\mu$ A	39 k	33 k
500 $\mu$ A	22 k	22 k
1 mA	12 k	10 k
3 mA	3k9	3k3
5 mA	2k2	2k2

and vice versa. The two diodes D1 and D2 are the (wired) OR gate shown in the block diagram. The voltage at the junction of these diodes ( $u_C$ ) is 'high' when the voltage  $u_M$  is outside the 'window', causing D11 to light: 'escaped'.

As long as  $u_C$  remains high, capacitor C1 will be charged. If  $u_C$  becomes 'low' ('B' has caught 'A'), C1 discharges slowly through R11, R12 and D11. When the voltage on C1 falls below the voltage set by P4, the output of A4 swings high and D12 lights — Tag! The time that 'B' must 'hang on to A' depends on the setting of P4, and can be anything up to a few seconds.

The remainder of the circuit consists of the two VCOs. These circuits may be familiar by now: the modified 'simple CMOS squarewave generator' described in the Summer Circuits issue is also used in 'Ring the bell and win a prize', described elsewhere in this issue. For the first VCO, T1 and T2 are a current mirror and diodes D3...D6 are a bridge circuit. Together, these components are a kind of current-controlled impedance. Since the current mirror is fed through a series resistor, R14, the net result is a voltage-controlled impedance. This impedance is incorporated in a conventional CMOS oscillator circuit in such a way that voltage variations at the input (R14) cause changes in the output frequency. In other words, the complete circuit is a Voltage Controlled Oscillator, or VCO.



4

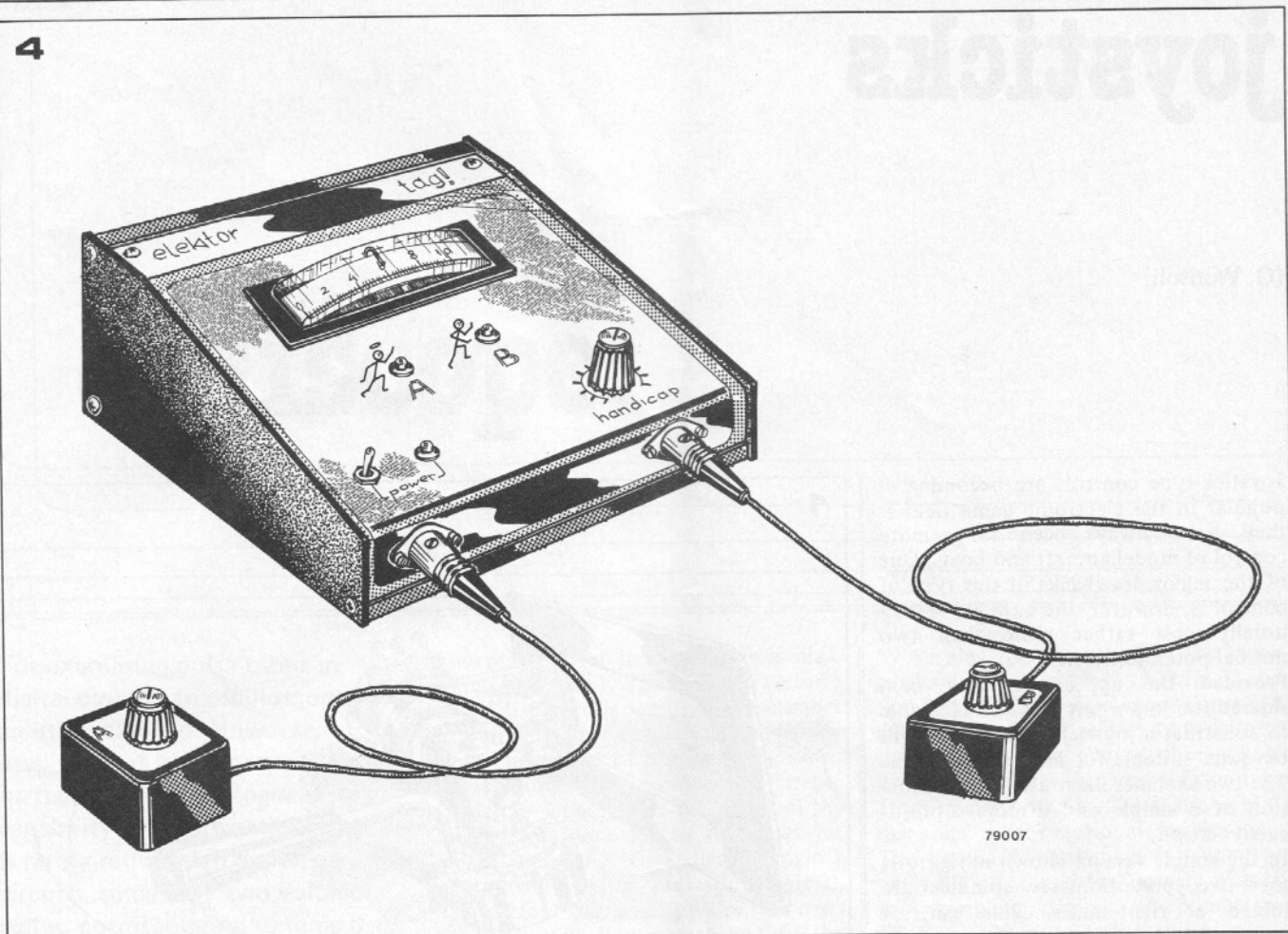

Figure 3. Printed circuit board and component layout (EPS 79007).

Figure 4. The only really important thing about the case is that it should be strong enough! The controls could also be mounted in the main case, but this usually proves awkward unless one of the players happens to be left-handed.

The output level from this oscillator can be set with P6. The second VCO is basically identical, with one minor exception: preset potentiometer P5 is included, so that the 'tracking' of the two oscillators can be adjusted.

### Construction

A printed circuit board design and corresponding component layout are shown in figure 3. Although only four NAND gates are used in the circuit, use of a single quad NAND gate IC proved unsatisfactory: the two oscillators tended to 'bite each other'. For this reason, two IC's are used, one for each VCO.

As far as the meter M is concerned, there is a wide range of options. Micro- or milliammeters with any sensitivity between  $50 \mu\text{A}$  and  $5 \text{ mA}$  f.s.d. can be used. In this case, the value of the series resistor R16 is chosen so that the meter reads full scale when the full supply voltage is connected across the series-connection of meter and resistor. The value of the resistor should be approximately:

$$R_{16} = \frac{U_b}{I_{f.s.d.}} \quad (\text{k}\Omega),$$

where  $U_b$  is in volts and  $I_{f.s.d.}$  (the full-scale sensitivity of the meter) is in milliamps. In the interest of saving the batteries in thousands of pocket calculators around the world, the Table lists values for R16 for several common full-scale sensitivities and for two supply

voltages. The nearest standard value has been chosen in each case — the meter doesn't have to be a precision instrument!

If a multimeter is available there is no real need to invest in a new meter for this circuit — unless, of course, one is afraid to let that expensive item fall into the hands off one's offspring. If a multimeter is to be used, R16 can be replaced by a  $1 \text{ k}$  resistor — just in case of accidental shorts — and the supply voltage is chosen equal to a suitable voltage range on the meter ( $10 \text{ V}$  f.s.d., for instance).

It is advisable to mount this type of circuit in a sturdy case. The players are liable to get highly excited! Figure 4 is just one possible suggestion. In this case, the two controls are mounted separately and connected to the main unit by means of a standard three-core (mains) cable.

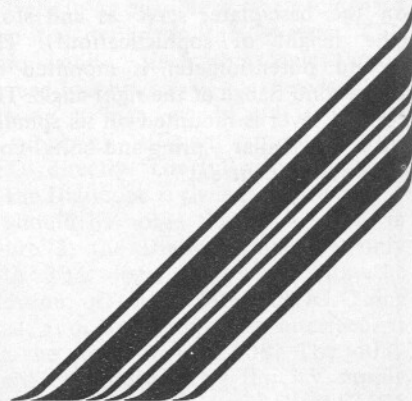



# joysticks

(G. Wunsch)

Joystick-type controls are becoming as popular in the electronic game field as they have always been for remote control of model aircraft and boats. One of the major drawbacks of this type of control is, however, the expense — they usually cost rather more than two normal potentiometers!

Provided the appearance isn't considered too important, it is quite feasible to construct a joystick control that will be quite suitable for most applications. The two sketches illustrate the construction of a simple and a more sophisticated version.

In the simple version shown in figure 1, the two potentiometer spindles are joined at right-angles. This can, of course, be done in several ways; using a block of brass or plastic with holes drilled in it, as shown, is probably as good as any. One of the potentiometers is mounted on a stand; the other is fastened to a control lever.

The more sophisticated version, shown in figure 2, works on the same basic principle: two normal potentiometers joined at right-angles. However, in this case two springs are included to return the control lever to neutral. The construction is, understandably, more complicated.

One of the potentiometers is mounted on a base-plate. A metal (or plastic) right-angle is mounted on the spindle. A spring is looped round the potentiometer spindle, with its open ends resting against a bolt. A longer bolt, mounted on the right-angle, engages the spring in such a way that the spring acts to centre the right-angle — and, with it, the potentiometer. Two further bolts, mounted on the base-plate, serve as end stops (the height of sophistication!). The second potentiometer is mounted on the second flange of the right-angle. The control lever is mounted on its spindle, with a similar spring-and-bolts construction to centre it.

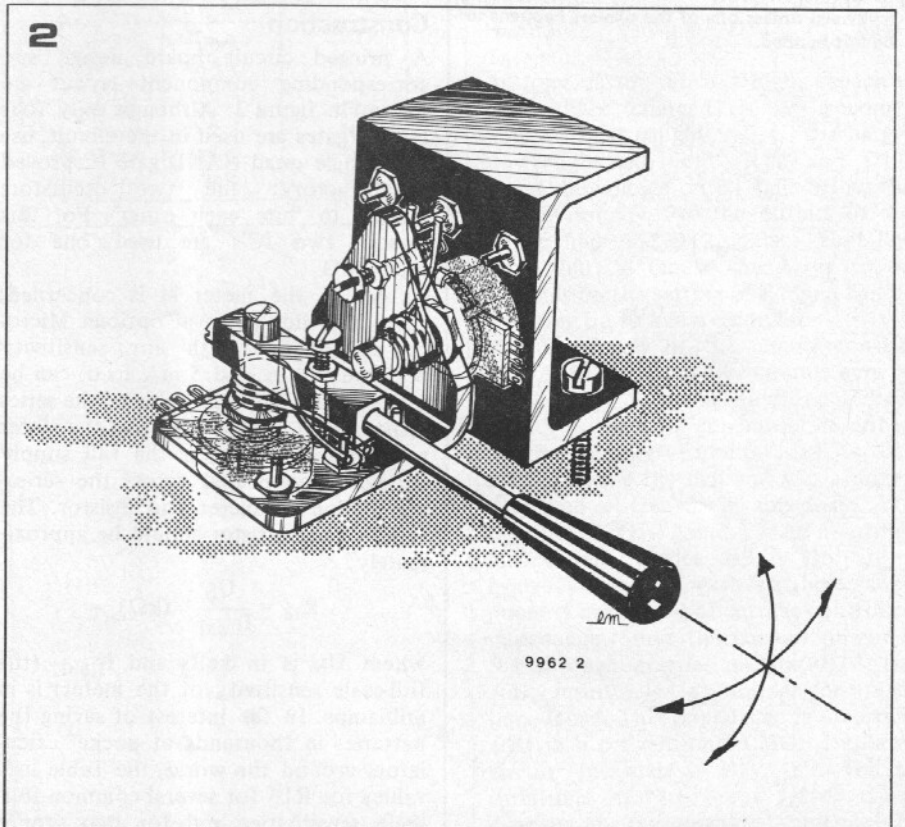
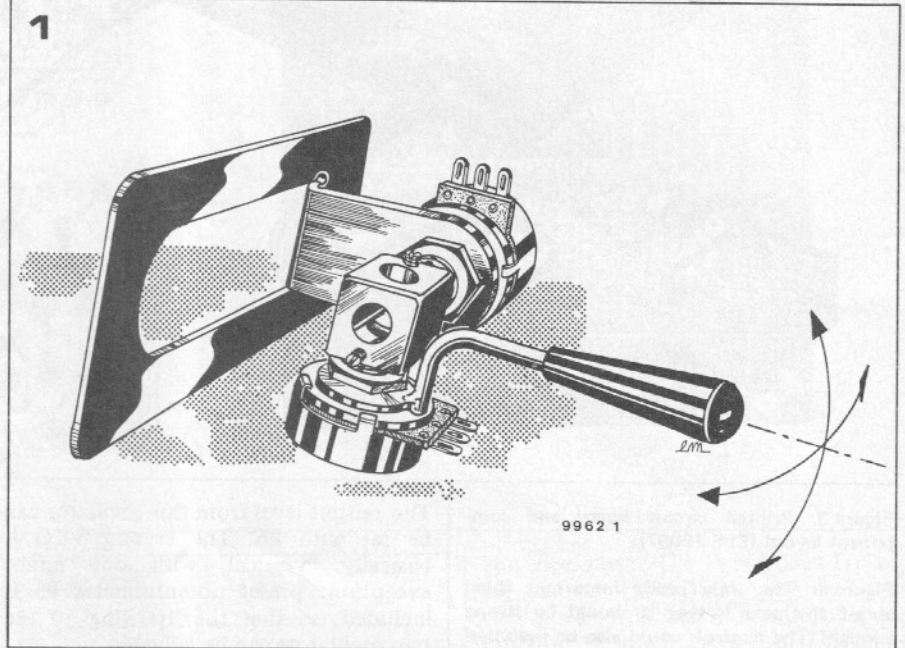



# digiscope

For examining pulse trains in digital circuits an oscilloscope is an invaluable aid. However, oscilloscopes are expensive, and furthermore the analogue display capability of a conventional 'scope is rarely required in digital circuits, since only two voltage states, corresponding to logic 0 and 1, are encountered. The Digiscope offers a low-cost alternative to the conventional oscilloscope for digital work, and displays digital pulse trains on two rows of light-emitting diodes.

E. Muller

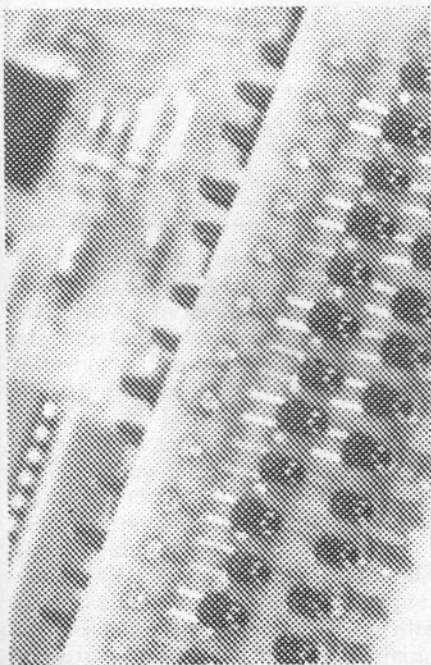

The principle of the Digiscope is illustrated in figure 1. The digital waveform to be displayed is sampled at a number of points and the value of the waveform at the instant of each sample (logic 0 or 1) is stored in a number of latches (flip-flops). The Q and  $\bar{Q}$  outputs of the latches are connected to two rows of LEDs, the upper row indicating logic 1 and the lower row indicating logic 0. The pattern displayed by the two rows of LEDs will thus correspond to the digital waveform.

This is shown in figure 1, where a digital waveform is shown together with the corresponding display on the Digiscope. Any number of samples can be taken, and obviously the greater the number of samples per cycle of the waveform the more accurate will be the resulting display. However, the cost factor must be considered, since each sample requires a flip-flop and two LEDs, and a reasonable compromise of 16 flip-flops and 32 LEDs was adopted.

## Block diagram

Figure 2 shows the block diagram of the Digiscope. The memory consists of 16 D flip-flops. A 'timebase' consisting of a clock oscillator, 4-bit counter and 1-of-16 decoder 'scans' the memory, i.e. takes the clock input of each flip-flop high in turn. The input signal is connected to the D inputs of all the flip-flops, so that if the input is high when the clock input of a particular flip-flop is activated then the Q output of that flip-flop will go high. Conversely, if the input signal is low then the output of the flip-flop will remain low. The scanning of the memory by the timebase is analogous to the spot sweeping across the screen of a conventional oscilloscope, hence the term 'timebase' is used for this function.

Like the timebase of a conventional oscilloscope, the timebase of the Digiscope has coarse and fine speed controls. Fine speed control is effected

by varying the frequency of the clock generator between 100 kHz and 500 kHz, whilst coarse speed control is effected by preceding the 4-bit counter by a variable frequency divider, whose division ratio can be varied from 1 to 1000 in steps of 1, 2, 5, 10, 20... etc., just like a conventional oscilloscope. The timebase speed range is from 4  $\mu$ s per LED i.e. 64  $\mu$ s for a single scan of the complete display, to 20 ms per LED, i.e. 320 ms to scan the display.

## Trigger circuit

In addition to a timebase with a wide speed range it is also important to have a reliable trigger circuit. When the digiscope is used to display repetitive pulse trains the trigger circuit ensures that each timebase sweep starts at the same point in successive pulse trains. If the timebase were not synchronised to the display in this manner then the display would appear to run in one direction or the other depending on the relative speeds of the timebase and the input signal. In addition to being triggered by the input signal the timebase may also be triggered by an external signal or allowed to free run.

## Complete circuit

In order to keep the circuit as simple and cheap as possible it was decided to base the design on the 74-series TTL logic family, since this logic family is readily obtainable, inexpensive, can operate at high speeds and is capable of supplying sufficient current to drive LEDs directly. The full circuit diagram of the Digiscope is given in figure 3.

It should be noted that as it stands in figure 3, the Digiscope operates only with TTL logic. However, with the addition of one 4050 CMOS IC, being used as a level converter interface, it can be used with CMOS. The 4050 should be powered by the 5 V supply in the Digiscope, this will allow CMOS



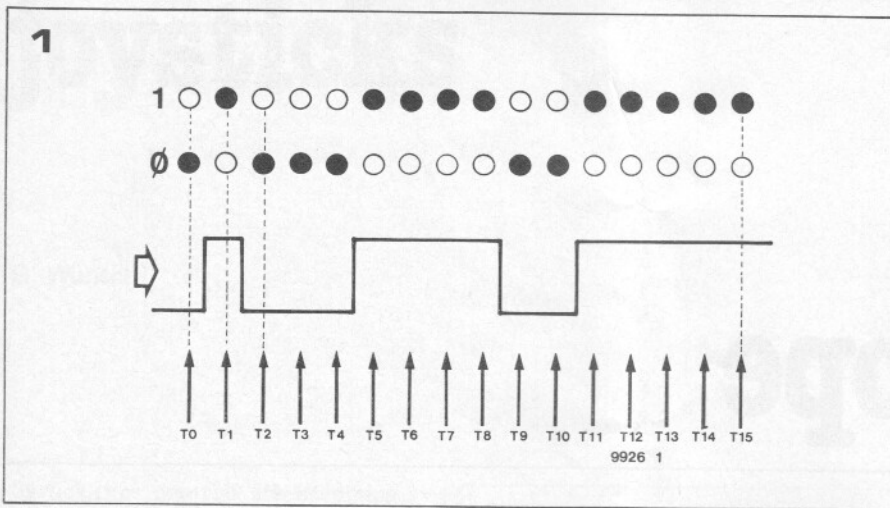
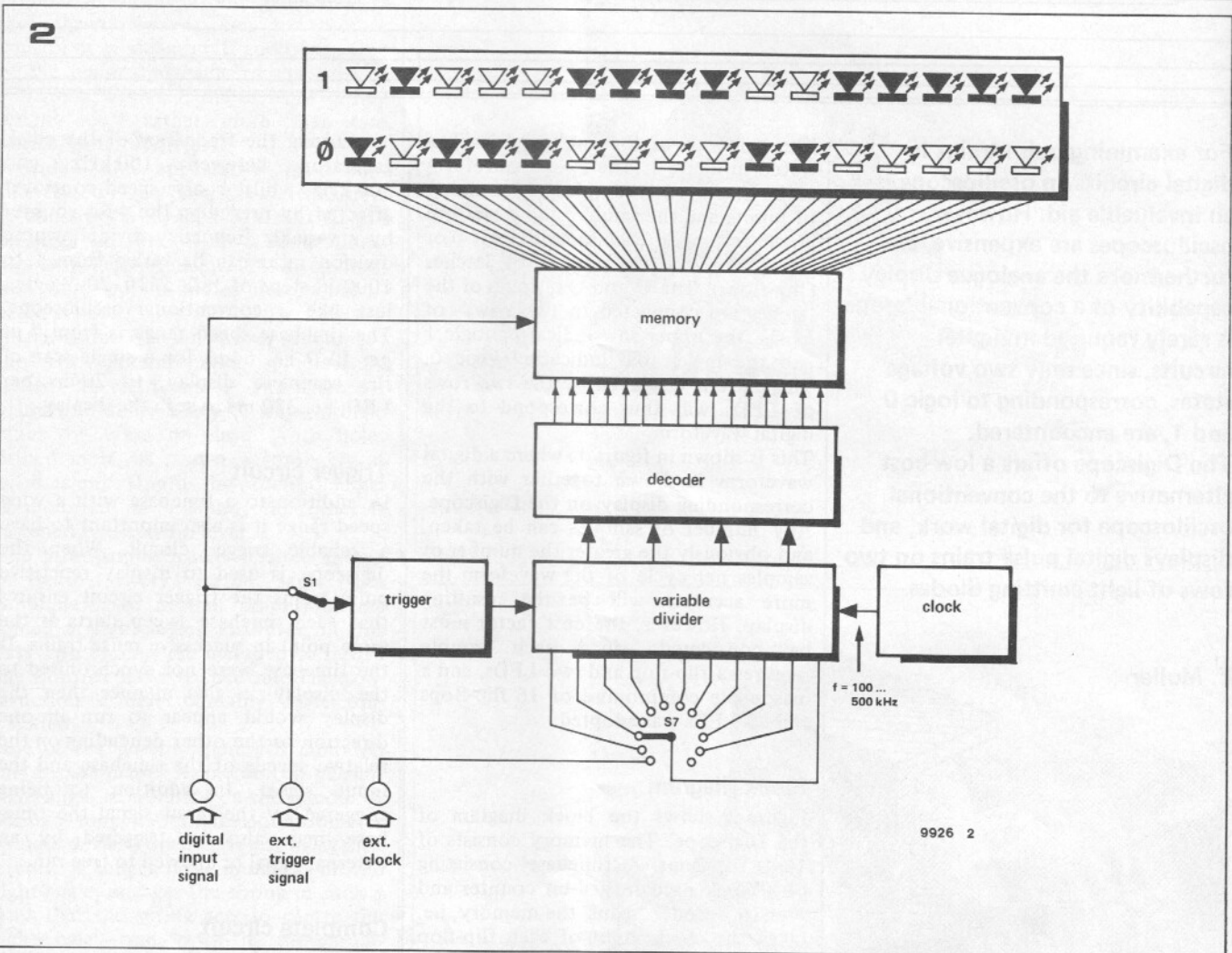

Table 1

S7 position %	1000	4	msec/LED
%	500	2	msec/LED
%	200	800	µsec/LED
%	100	400	µsec/LED
%	50	200	µsec/LED
%	20	80	µsec/LED
%	10	40	µsec/LED
%	5	20	µsec/LED
%	2	8	µsec/LED
%	1	4	µsec/LED



circuits with a supply voltage of up to about 15 V to be tested.

Since there are 6 buffer amps in one 4050, it can also be used for level conversion of the 'clock input', and 'trig. input'. Since the 4050 can only drive 2 TTL loads, it is advisable to connect 2 of the buffer amps in the 4050 parallel, since the input loading of the Digiscope is 3.

The display memory consists of 16 D flip-flops contained in 8 7474 dual D flip-flop packages, IC11 to IC18. Since the D inputs of these flip-flops present a total of 16 TTL loads and a normal TTL output can drive only 10 TTL

Figure 1. This diagram illustrates the principle of the Digiscope.

Figure 2. Block diagram of the Digiscope.

Figure 3. Complete circuit of the Digiscope. Resistors R29a, b, c and d can, of course, be replaced by a single resistor (R29) as on the p.c. board.

Table 1. Listing of the timebase ranges for each position of the timebase switch.

loads it is necessary to drive the D inputs of FF7 to FF22 in two groups of 8. This is done by a pair of EXOR gates, which buffer the input signal and provide a choice of normal or inverted display depending on the position of S9. The memory is scanned by a 74154 binary to 1-of-16 decoder, IC10, which is driven by the four-bit counter, IC7. The remainder of the timebase circuit comprises the clock generator (which consists of two monostable multivibrators, MMV3 and MMV4, cross-coupled to form an astable multivibrator with good frequency stability) and the variable frequency divider consisting of



3

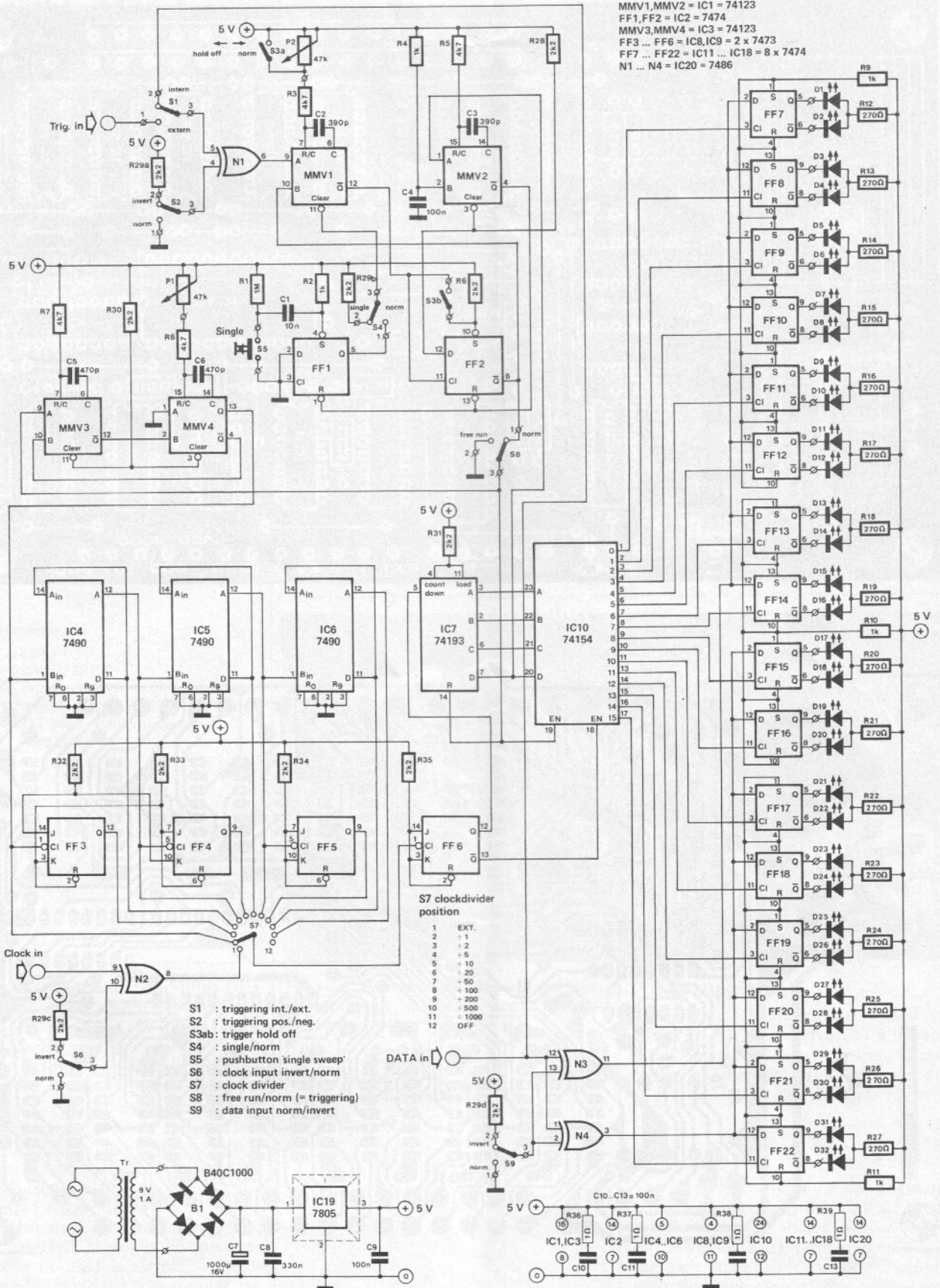



4

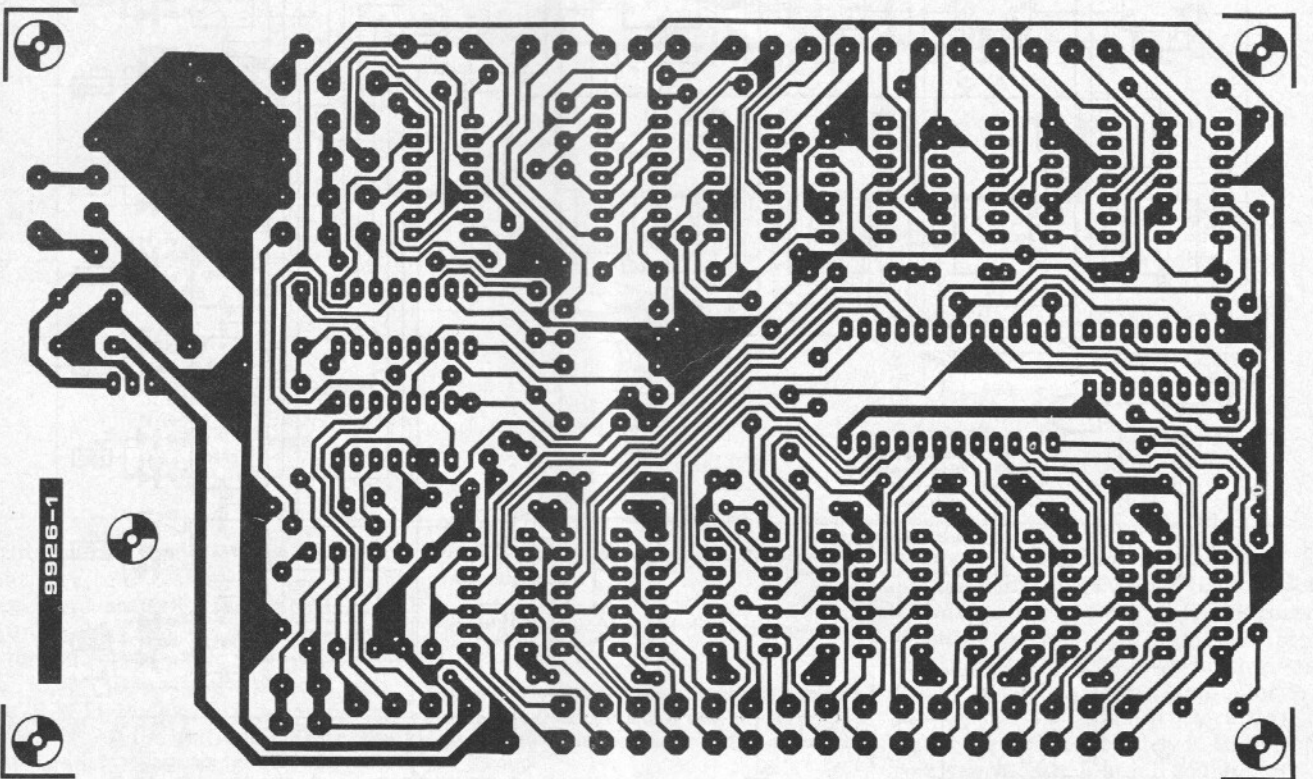
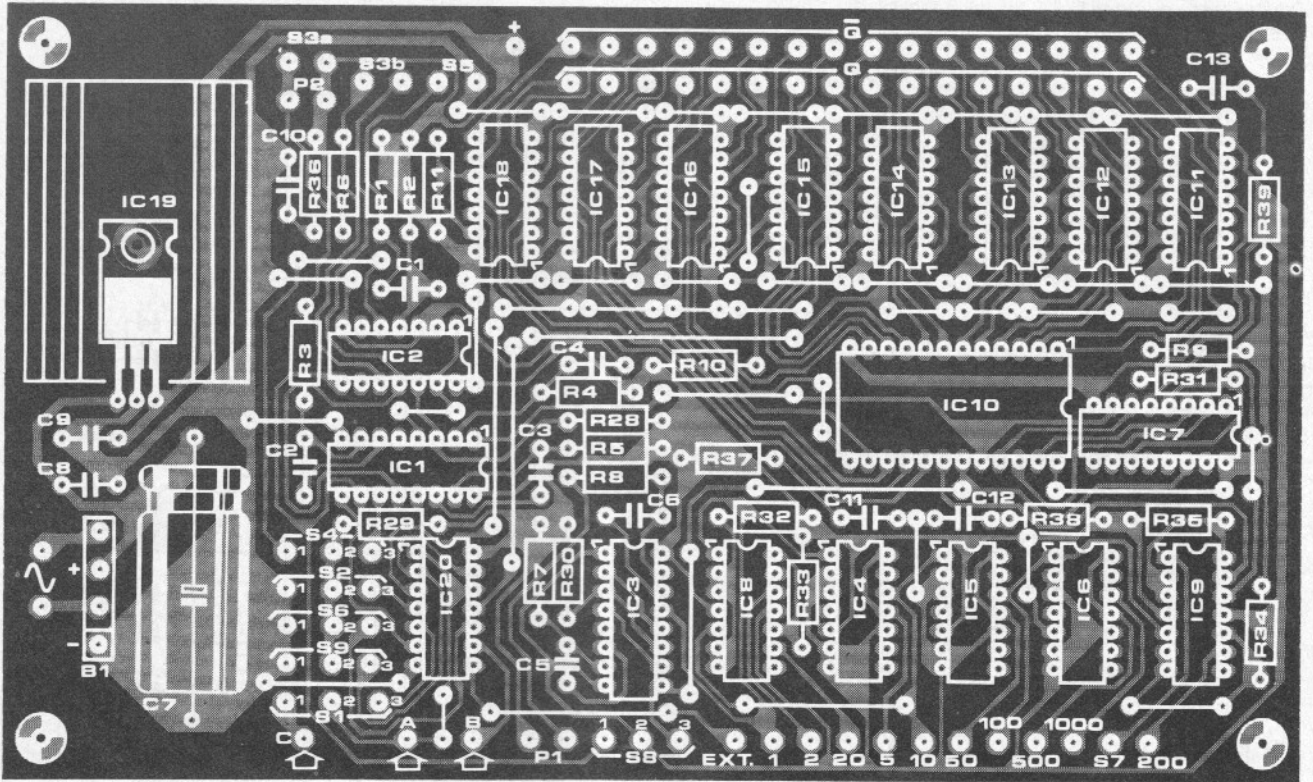

## parts list to figures 3, 4 and 5

## Resistors:

R1 = 1 M  
 R2,R4,R9,R10,R11 = 1 k  
 R3,R5,R7,R8 = 4k7  
 R6,R28 ... R35 = 2k2  
 R12 ... R27 = 270  $\Omega$   
 R36 ... R39 = 1  $\Omega$   
 P1,P2 = 47 k

## Capacitors:

C1 = 10 n  
 C2,C3 = 390 p  
 C4,C9 ... C13 = 100 n  
 C5,C6 = 470 p  
 C7 = 1000  $\mu$ /10 V  
 C8 = 330 n

## Semiconductors:

IC1,IC3 = 74123  
 IC2,IC11 ... IC18 = 7474  
 IC4,IC5,IC6 = 7490  
 IC7 = 74193  
 IC8,IC9 = 7473  
 IC10 = 74154  
 IC19 = 7805  
 IC20 = 7486  
 D1 ... D32 = LED  
 B1 = B 40 C 1000 (40 V/1 A  
 bridge rectifier)

## Miscellaneous:

S1,S2,S4,S6,S8,  
 S9 = switch SPDT  
 S3 = switch DPDT  
 S7 = switch single pole 11  
 (12-)way transformer at  
 least 9 V/1 A

counters IC4 to IC6 and flip-flops FF3 to FF6. The ranges covered by the timebase switch are listed in table 1. An external clock signal may also be fed in via EXOR gate N3 in normal or inverted form.

The trigger circuit comprises monostables IC1 and flip-flops IC2, and offers a variety of triggering modes. S1 offers a choice of internal or external triggering, whilst S2 selects between normal and inverted trigger signal. By switching S4 to the single-shot mode the timebase can be triggered manually by pressing S5. S3 can be used to switch to 'hold-off', in which mode the trigger pulse can be delayed for a variable period. Finally, the trigger circuit can be inhibited and the timebase allowed to run continuously by switching S8 to the 'free-run' position.

5

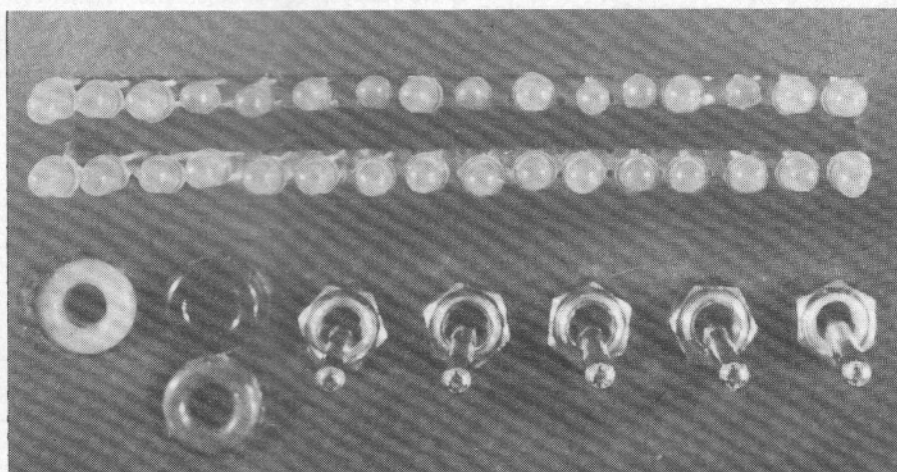
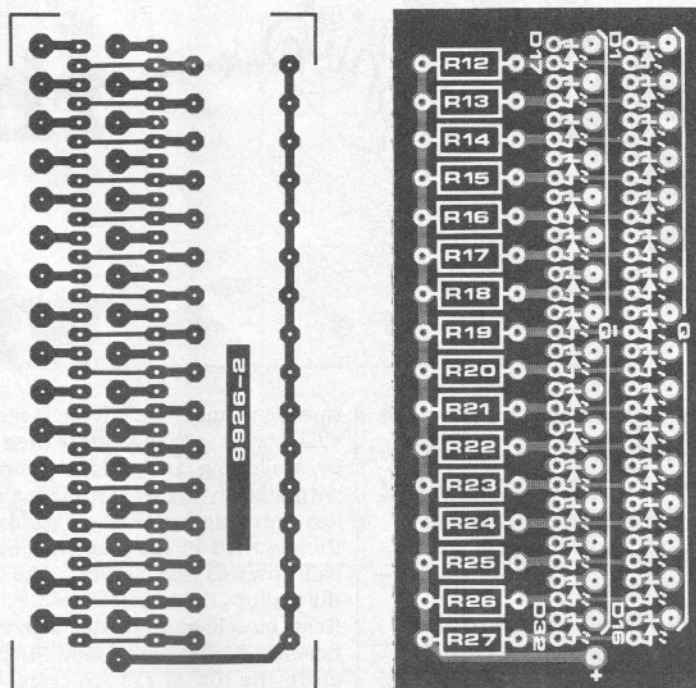

Figure 4. Printed circuit board and component layout for the Digiscope, excluding the display section (EPS 9926-1).

Figure 5. Printed circuit board and component layout for the display section of the Digiscope (EPS 9926-2).

## Power supply

The Digiscope requires a stabilised 5 V power supply. The circuit of a suitable power supply consisting of a transformer, bridge rectifier, reservoir capacitor and an IC regulator is also shown in figure 3.

## Construction

The complete circuit of the Digiscope is mounted on two printed circuit boards. The p.c. board whose layout is shown in figure 4 accommodates all the logic circuits and the power supply, with the exception of the mains transformer, whilst the display is mounted on the board whose layout is given in figure 5. This should be connected to the main board using a 33-core ribbon cable or something similar.





# ring the bell and win a prize!

One of the favourite attractions at fair-grounds has always been some variation of 'bash-the-block-with-a-mallet'. Originally, this was a purely mechanical device, although of recent years technology has advanced to the stage where no self-respecting fair-ground attraction is complete without a dazzling display of flashing lights. However, electronics have now progressed to the point where a portable version is possible — suitable for desk-top use.

In olden times, the strongest men in the village used to demonstrate their prowess by walloping an innocent wooden peg with a heavy mallet. Through a more-or-less intricate system of sturdy levers, this resulted in the launching of a metal ball towards the heavens; the mightier the wallop, the higher it rose.

Real muscle-men could deliver a sufficiently hard blow to send the ball right up to the top of the structure, where it would hit a bell with an almighty clang. This won them a prize and, more importantly, the esteem of all those who witnessed the feat.

Nowadays, of course, the battle for superiority is more likely to be fought out indoors — specifically, at parties and business meetings. The desk-top model described in this article should therefore fulfil a major need. Operated as it is by fist-power instead of by means of a blunt instrument, it can also prove useful as an ideal 'fury-indicator' for managers. In fact, every executive should have one.

## The circuit

Before even starting to design the circuit, a suitable force sensor must be found. This should not only be sufficiently sturdy; it should also be reasonably cheap and readily available. The solution chosen may be somewhat inelegant, but it has proved highly satisfactory in practice.

The sensor consists of a piece of conductive foam plastic, of the type currently in use for packing CMOS IC's. The specific resistance of this foam drops dramatically when the foam is compressed — this is not particularly surprising, in view of the fact that the carbon particles in the foam become more tightly packed as the volume decreases. Remember the carbon mike?

The mechanical construction is shown in figure 1. The foam is placed between two metal plates (with wires attached) and this 'sandwich' is placed in a suitable wooden holder. A two-piece wooden block serves to spread the force

1

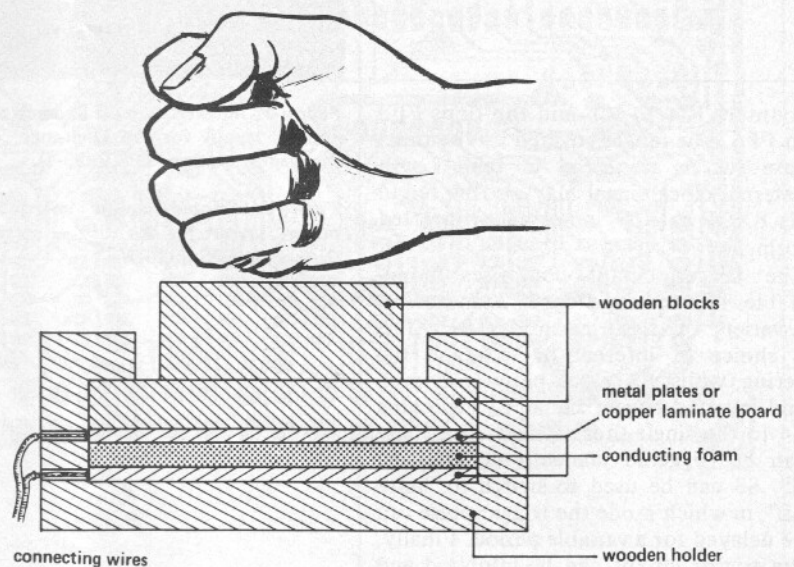

2

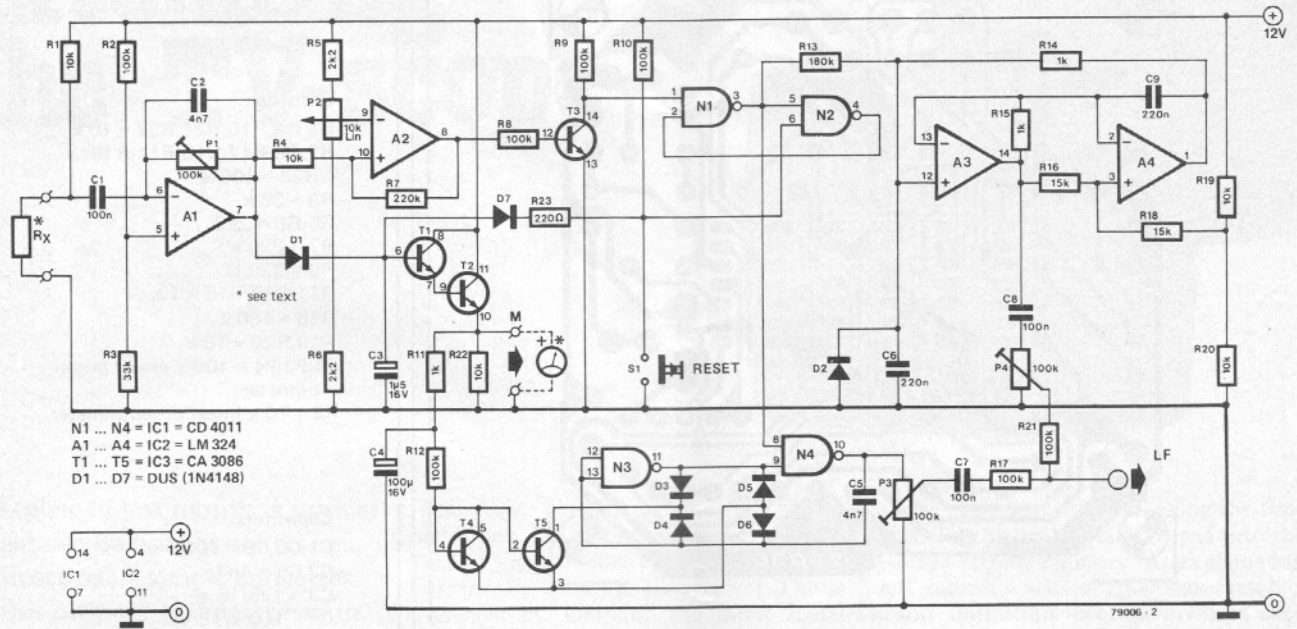

3

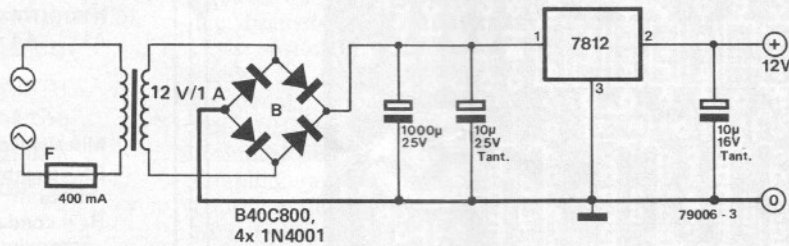

of the blow evenly over the upper metal plate. For most ordinary mortals, with the possible exception of karate experts, it is advisable to glue some softer material over the upper surface of the target area - hitting a solid wooden block with the bare hand, hard, is not everybody's idea of fun!

Having settled the details of the sensor, it can now be reduced to a small rectangle marked  $R_X$  and included in the circuit shown in figure 2. The sensor,  $R_X$ , and  $R_1$  together form a potential divider. A sudden change in the resistance  $R_X$  causes a sudden jump in the voltage at the  $R_X/R_1$  junction. This voltage 'spike' is passed through  $C_1$  to the input of opamp  $A_1$ . The gain of this amplifier stage can be preset by means of  $P_1$ , to suit the characteristics of the sensor and the (expected) strength of the potential customers. The output from  $A_1$  (a positive-going spike) is passed to a peak detector and to a trigger circuit.

The peak detector consists of  $D_1$  and  $C_3$ . The highest voltage level appearing at the output of  $A_1$  as a result of a blow on the sensor is 'stored' in  $C_3$ . This

Figure 1. The sensor consists basically of conducting foam, sandwiched between two metal plates and mounted in a wooden box. Copper laminate board can, of course, be used instead of the metal plates.

Figure 2. Complete circuit for 'Ring the bell and win a prize'.

Figure 3. A suitable 12 V power supply.

voltage is buffered by the super-emitter-follower  $T_1/T_2$  and is available as the output voltage  $U_p$ . It can be used to drive a pointer instrument (e.g. an AVometer) or a LED voltmeter, as will be described later.

The trigger circuit consists of  $A_2$ ,  $R_4 \dots R_7$  and  $P_2$ . The trigger threshold (and thus the strength of the blow required to 'score') can be set with  $P_2$ . The output from  $A_2$  is fed, via  $T_3$ , to a set/reset (RS) flip-flop consisting of  $N_1$  and  $N_2$ . This flip-flop controls the 'ding' generator,  $A_3/A_4$ , which is derived from the 'electronic gong' (see the 'Summer Circuits' 1978 issue, circuit no. 13). The output can be fed, via  $P_4$ , to a power amplifier; if a suitably 'hefty' amplifier and loudspeaker are used, a very gratifying 'bong' will be produced.

To further enhance the audible effect, a VCO (voltage controlled oscillator) is also included. The peak output voltage,  $U_p$ , is fed via  $R_{11}$  to  $C_4$ .  $C_4$  will therefore charge up slowly to  $U_p$ , causing the VCO ( $T_4, T_5, N_3, N_4$  and the associated diodes, resistor and capacitor) to produce a slowly-rising wail. However, the VCO can only operate if the



4

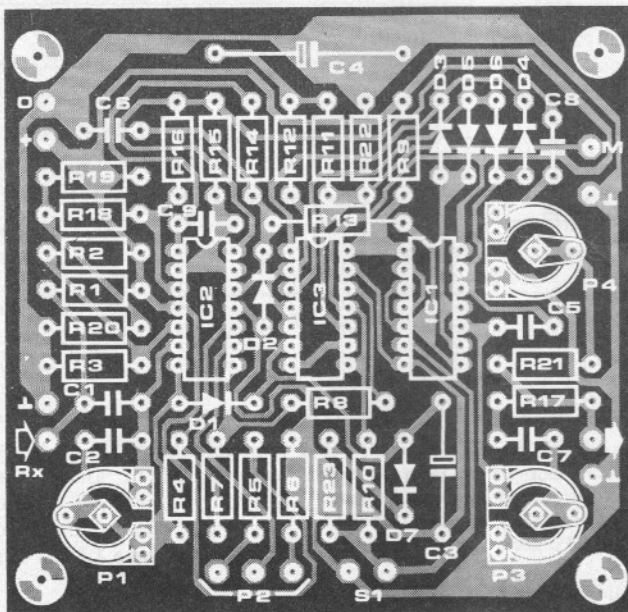
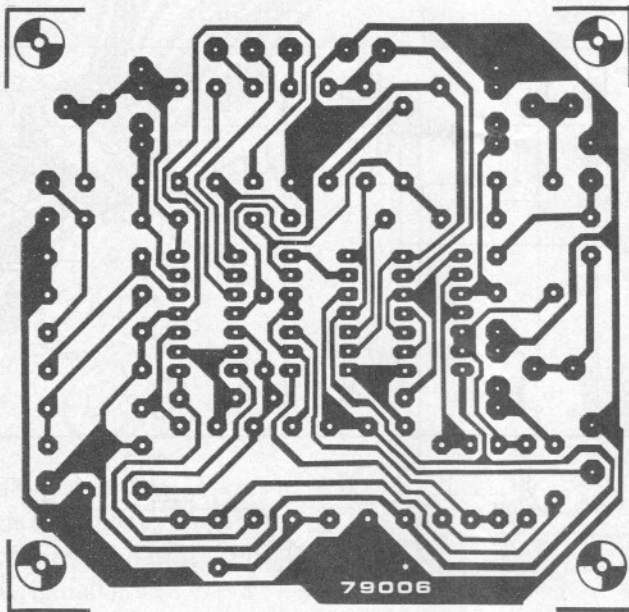

## Parts list

## Resistors:

R1,R4,R10,R21,R22 = 10 k  
 R2,R8,R12,R13,R14,R15,  
 R23 = 100 k  
 R3 = 33 k  
 R5,R6 = 2k2  
 R7 = 220 k  
 R9 = 220  $\Omega$   
 R11,R17,R18 = 1 k  
 R16 = 180 k  
 R19,R20 = 15 k  
 P1,P3,P4 = 100 k preset poten-  
 tiometer  
 P2 = 10 k linear potentiometer

## Capacitors:

C1,C6,C8 = 100 n  
 C2,C5 = 4n7  
 C3 = 1 $\mu$ 5/15 V  
 C4 = 100  $\mu$ /15 V  
 C7,C9 = 220 n

## Semiconductors:

T1 ... T5 = IC3 = CA 3086  
 D1 ... D7 = DUS  
 N1 ... N4 = IC1 = CD 4011  
 A1 ... A4 = IC2 = LM 324

## Miscellaneous:

S1 = pushbutton, single-pole,  
 make  
 R<sub>x</sub> = conducting foam plastic,  
 approximately 3" square  
 (7 x 7 cm).

RS flip-flop N1/N2 has been triggered.  
 The circuit can be reset by means of S1:  
 C3 is rapidly discharged and the  
 RS flip-flop is reset.

## Final notes

The most sensational effect can be  
 obtained by using a LED voltmeter to  
 indicate the  $U_p$  output level. A suitable  
 circuit is the 'UAA 180 LED voltmeter'  
 described in Elektor 33, January 1978,  
 p. 1-20.

Both the circuit described here and the  
 LED voltmeter will operate on a simple  
 12 V supply like the one shown in fig-  
 ure 3.



Figure 4. Printed circuit board and component layout for the circuit shown in figure 2 (EPS 79006).

# extending the TV-scope

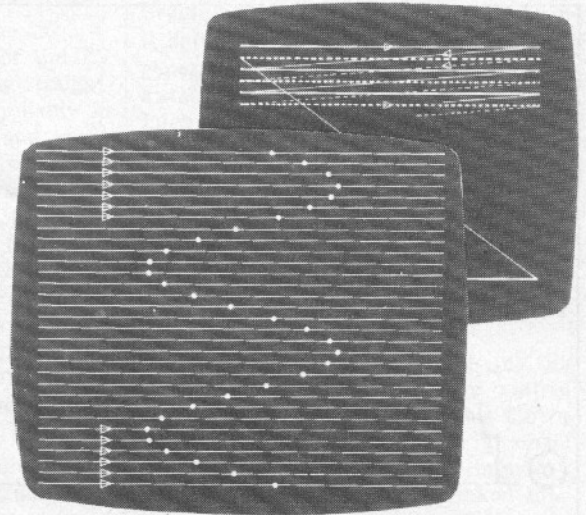

As explained last month, a normal TV set can be used as an oscilloscope. A simple converter for this purpose was described in detail: the 'TV scope - basic version'. In an introductory article it was explained that this basic version could be extended, thereby eliminating its two major weaknesses: limited usefulness at high frequencies and lack of triggering facilities. Before discussing the details of the extension circuits, a fuller explanation of the underlying principles is in order.

The basic version of the TV scope, described last month, can be used to display low-frequency signals on the screen of a domestic TV receiver. This is achieved by sampling the input signal and using each sample to determine the position of a white spot on one line of the final picture. Sync pulses are added to complete the video signal, and an (optional) VHF/UHF modulator is included. The exact details of the circuits were described last month; for the discussion of the extension circuits it is sufficient to consider the basic version as a 'black box' with a low-frequency input and a video (or VHF/UHF) output. The only important technical details for the present are the sampling rate (TV line frequency, i.e. approximately 15 kHz), the fixed timebase frequency (TV frame frequency, i.e. 50 Hz, corresponding to 20 ms) and the lack of triggering facilities.

To extend the capabilities of the TV scope, the first priority is to get away from the fixed timebase frequency. Basically, what is required is a timebase expander, that is, a circuit that will 'slow down' a signal to any desired 'speed'. The signal goes in at one end, at high frequency, and comes out at the other with its frequency reduced to a manageable value. In a way, a tape recorder with several tape speeds is equivalent to a timebase expander. If a signal is recorded at, say, 15"/s and then played back at 7½"/s, the frequency of the output signal will be half that of the original. This corresponds to 'timebase expansion'.

Timebase expansion can also be achieved by purely electronic means. In the extended version of the TV scope, the (by now familiar) bucket-brigade memory is used. The principle is simple: feed the signal into a bucket-brigade memory using a suitable (input) clock frequency and then retrieve it from the memory using a lower clock frequency. Figure 1 illustrates this. The original signal is shown at 'a'. It is assumed that the frequency is too high for the basic version of the TV scope to handle comfortably, so timebase expansion is required: the

signal must be 'stretched' along the time axis. To this end, it is first read into the bucket-brigade memory. As explained in last month's article 'Analogue reverberation unit', this process involves sampling the input signal. In figure 1, the (sampling) clock pulses are shown at 'b' and the sampled signal, as stored in the memory, is signal 'c'. The latter signal consists of a succession of discrete voltages, and these can now be read out of memory using a lower clock rate (signal 'd'). The output signal ('e') is a similar succession of discrete steps, with one major difference: the steps are longer. Suitable filtering of this signal results in the final output signal 'f'. As can be seen, this signal has the same 'shape' as the original signal ('a'), but it has been 'stretched' over a longer period of time.

This figure illustrates the function of the extension circuit for the TV scope. Relatively high-frequency signals are read into a bucket-brigade memory, using a suitable high clock frequency, and then read out using a low clock frequency. The two clock frequencies are chosen such that the 'stretched' output signal can be clearly displayed on the basic version of the TV scope, in spite of its fixed 20 ms timebase.

A block diagram for the extended version of the TV scope was included last month in the introductory article, and it is repeated here (figure 2). The operating principle should, by now, be fairly clear. As explained earlier, two bucket-brigade memories are used (per channel). These are used alternately: as one is storing the input signal, the contents of the other are being read out and displayed on the screen. This additional complication is necessary if the display is to remain uninterrupted: if only one memory were available, the different clock frequency during the read-in cycle would make the display useless during that period.

A slight simplification of this block diagram is possible: the selector switch at the input to the two memories can be omitted. When a memory is being used as 'display memory', i.e. when it is being

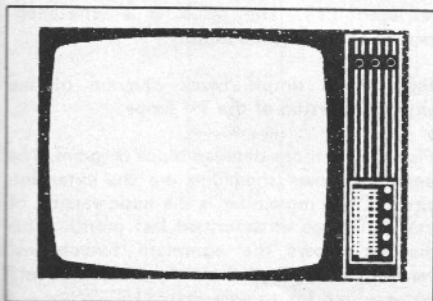



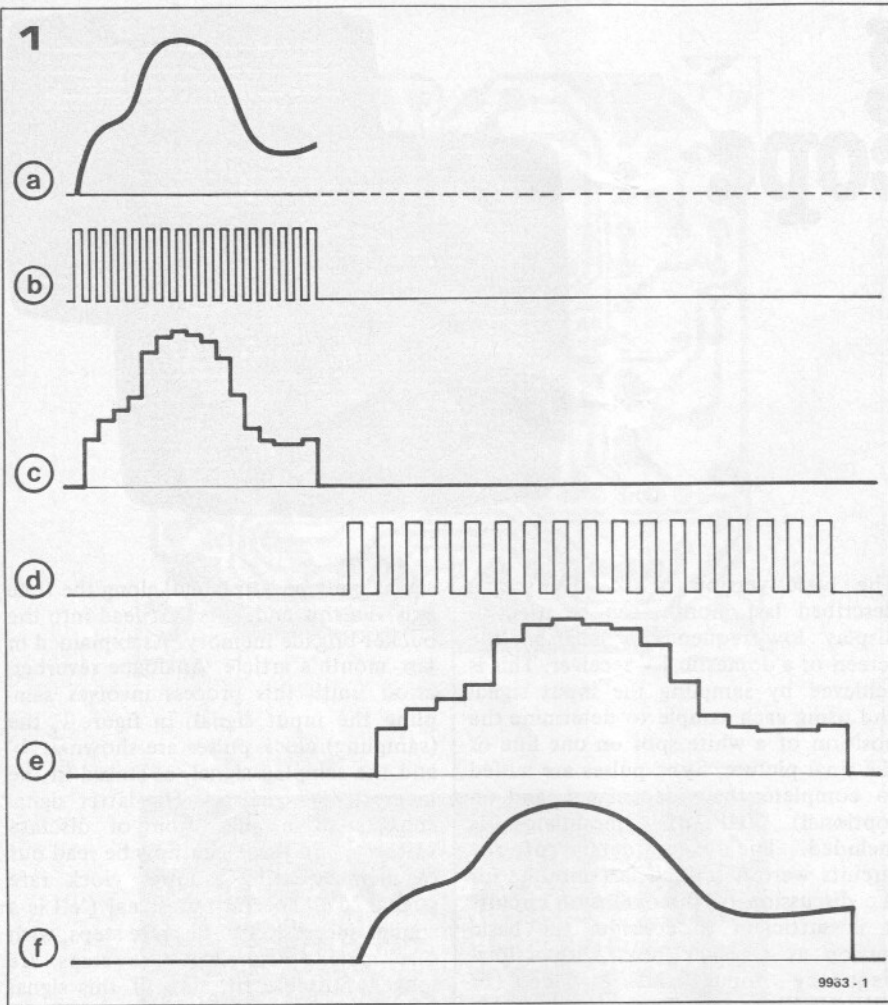

9963 - 1

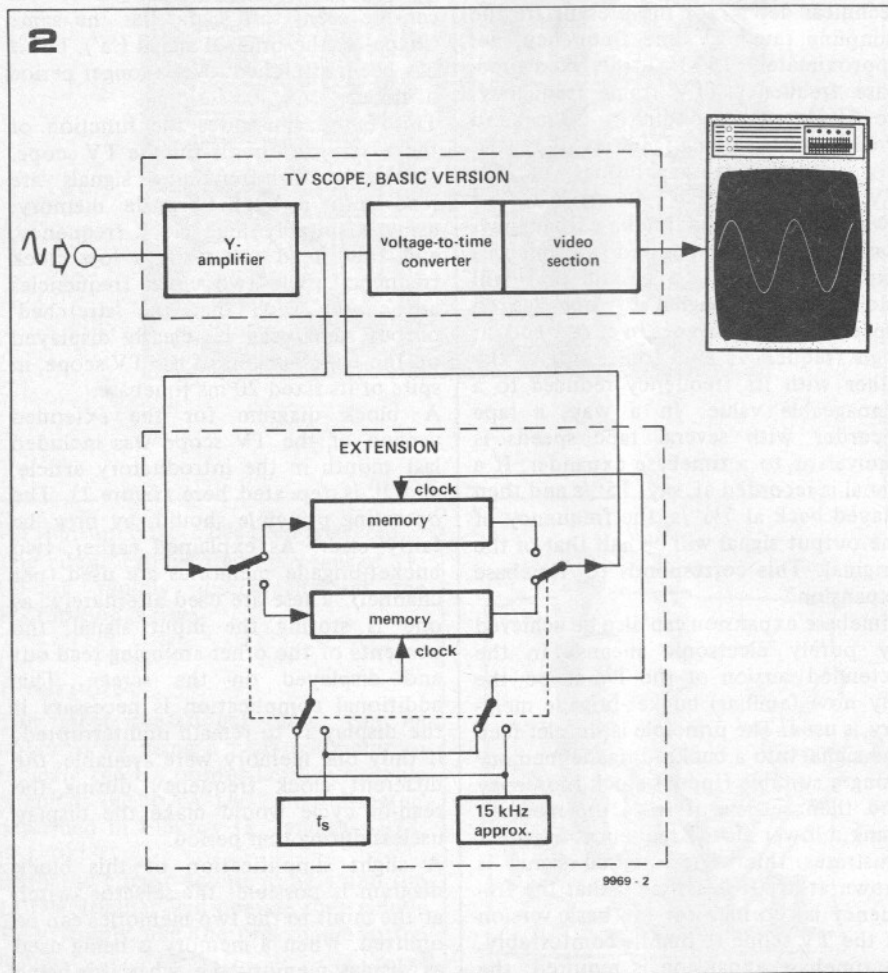

9969 - 2

read out, any new signal entered into it will remain unused — it will be lost during the following read-in cycle.

In the more detailed block diagram shown in figure 3, this input selector switch is omitted. Figure 3 is the 'final' block diagram of the extended version of the TV scope. The shaded portions are the extension circuits, which will be described in greater detail next month; the remainder is the basic version of the TV scope, as described last month. Some of the sections are shown in dotted lines, and these are only required for the two-channel version of the TV scope — i.e. if two signals are to be displayed on the screen simultaneously. If a single-channel version is sufficient, these portions may be omitted.

The basic structure should be fairly clear by now.  $Y_A$  is the input amplifier for (one channel of) the TV scope; the circuit details were discussed last month. The output signal  $u_{yA}$  is fed direct to the inputs of two analogue shift registers (bucket brigade memories), A1 and A2. At any given moment, one of these shift registers operates as 'input memory' and the other as 'display memory'. The 'input memory' samples and stores the input signal,  $u_{yA}$  (as noted earlier, the same signal is also stored in the 'display memory', but it is lost during the next read-in cycle). The clock frequency for the read-in cycle — i.e. the sampling frequency — determines the ultimate 'timebase expansion'.

Figure 1. The basic principle of 'timebase expansion'. The original signal, 'a', is sampled ('b' and 'c'), slowed down ('d' and 'e') and retrieved ('f'). The result is a 'stretched' replica of the original input.

Figure 2. A simple block diagram of the extended version of the TV scope.

Figure 3. A more detailed block diagram. The portions shown shaded-in are the extension circuits, the remainder is the basic version of the TV scope as described last month. This diagram shows the complete two-channel version; the sections shown in dotted lines are not required for a single-channel TV scope.

This signal is generated by the 'input timebase' - the latter being basically equivalent to the timebase in a normal oscilloscope: the input clock frequency determines the time scale along the X-axis in the final display. The phrase 'input timebase' is used to distinguish this circuit from the existing timebase in the basic version of the TV scope (the circuit that provides the clock- and sync pulses required for the actual display).

As the input signal is being sampled and stored in the input memory, the information stored in the other memory during the previous cycle is displayed on the screen. To this end, the display memory receives its clock signal,  $u_{line}$ , from the (output) timebase. The frequency of this clock signal can be either equal to or half of the fixed sampling rate of the basic version of the TV - approximately 15 kHz or 7.5 kHz. The output from the display memory, selected by  $S_a$ , is fed to a low-pass filter in order to retrieve the original waveform (see figure 1, e and f). This signal is then processed by the circuits already described in the basic version of the TV scope and displayed on the screen of the television receiver. When the display cycle is completed, the electronic switches  $S_a$ ,  $S_c$ ,  $S_d$  (and  $S_b$ ) are operated; the input memory becomes display memory and vice versa.

Obviously, the circuits for the second channel (shown in dotted lines in figure 3) operate in exactly the same way.

### Control signals

Even if the basic principle of the TV scope may by now seem fairly straightforward, getting it to work reliably in practice is another matter and some fairly intricate control circuitry is required. Two different clock signals are required for the memories: 256 pulses at the desired sampling frequency during the input cycle, followed by 256 pulses at TV line frequency (or half that) during the display cycle. Moreover, the two clock pulse trains ( $\emptyset 1$  and  $\emptyset 2$ ) must be fed to the memories at the correct point in the input and display cycles.

Since the memories are used alternately as input and display memory, and since the changeover occurs at the end of each cycle as determined by the  $u_{reset}$  pulses from the (output) timebase, the two clock signals must obviously be linked in some way to the  $u_{reset}$  pulses. This is illustrated in figure 4. As can be seen, a further signal  $u_m$  is generated, which changes state at every  $u_{reset}$  pulse. This signal determines which of the memories is to operate as input memory and which is to operate as display memory: it controls the electronic switches  $S_a \dots S_d$  in figure 3. The beginning of each display cycle is determined by the signal  $u_x$ . This signal goes 'high' shortly after each reset pulse, the delay between  $u_{reset}$  and  $u_x$  determining the position of the actual display along the time-axis ('X-position'). The

beginning of the input clock pulse train is determined in a similar way by pulses generated by the trigger circuit, so that a stable picture can be obtained.

Each pulse train, both for  $\emptyset 1$  and for  $\emptyset 2$ , consists of 256 pulses. The frequency of the output clock pulses is normally equal to TV line frequency; the input clock frequency is higher, and is determined by the desired time scale in the final display. The frequency of the  $u_{reset}$  pulses corresponds to TV frame frequency (50 Hz).

All the electronics involved in the memory circuits, including the control circuits that produce the signals shown in figure 4, are mounted on a single printed circuit board - the 'memory board'. This board can be linked into the basic version of the TV scope described last month, resulting in the 'extended version'.

### Controls and facilities

The various facilities offered by the extended version of the TV scope can be assessed from the front panel controls. The prototype front panel is shown in figure 5. Most of the controls are direct equivalents of their counterparts on a 'normal' oscilloscope:

The on/off switch, labelled 'power', requires little explanation. Above it, there are two 'intensity' controls. 'Signal intensity' sets the brightness for the displayed signal; 'grid intensity' does the same for the calibration graticule.

3

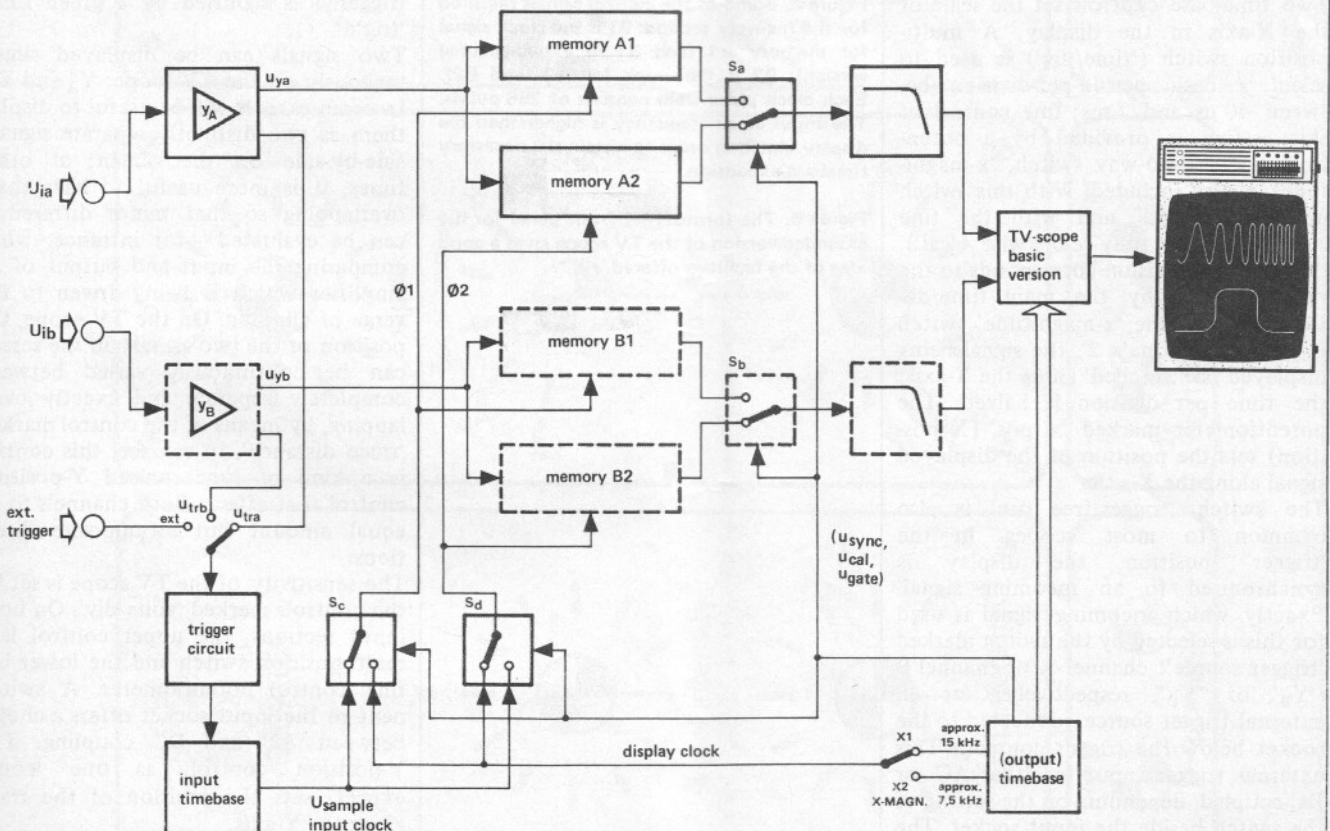



## 4

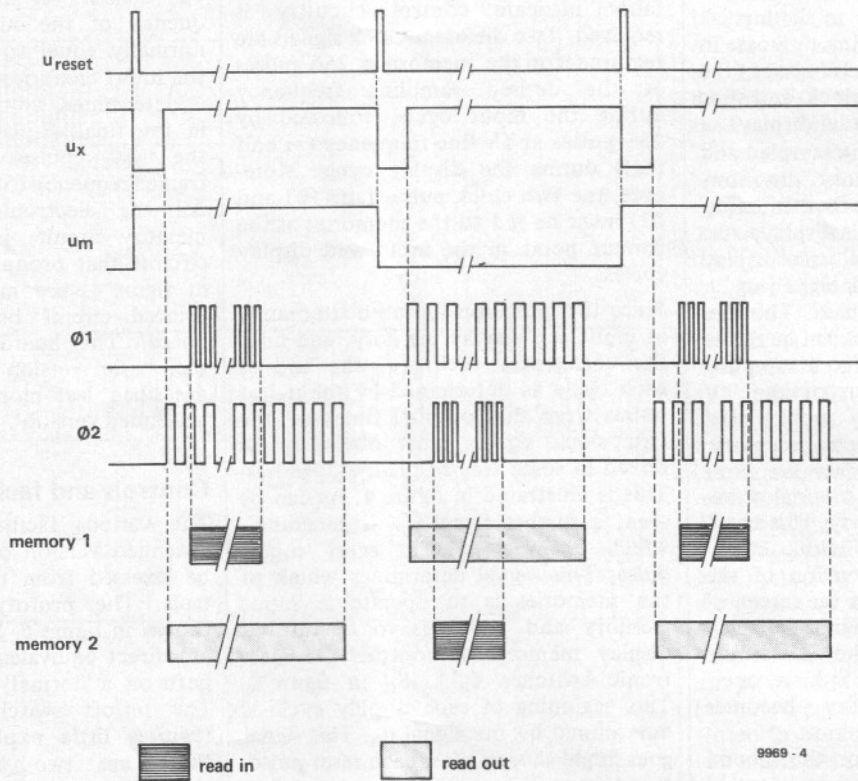

9969 - 4

Two time-base controls set the scale of the X-axis in the display. A multi-position switch ('time/div') is used to select a basic period-per-division between  $40 \mu\text{s}$  and  $2 \text{ms}$ ; fine control of this setting is provided by a potentiometer. A two-way switch, 'x-magnitude', is also included. With this switch in position 'x 1' and with the fine control turned fully clockwise ('cal'), the time per division corresponds to the value selected by the main time/div switch. When the 'x-magnitude' switch is set in position 'x 2', the signal being displayed is 'stretched' along the X-axis: the time per division is halved. The potentiometer marked 'x pos' (X position) sets the position of the displayed signal along the X-axis.

The switch 'trigger/free run' is also common to most 'scopes. In the 'trigger' position, the display is synchronised to an incoming signal. Exactly which incoming signal is used for this is selected by the switch marked 'trigger source': channel A or channel B ('Y<sub>a</sub>' or 'Y<sub>b</sub>', respectively), or an external trigger source connected to the socket below the trigger controls. This external trigger input is either AC- or DC-coupled, depending on the setting of the switch beside the input socket. The signal level at which triggering occurs is set by the 'trigger level' control; the fact that the TV scope is actually being

Figure 4. Some of the control signals required for the memory section.  $\emptyset 1$  is the clock signal for memory A1 (and B1 in a two-channel version);  $\emptyset 2$  is the clock for A2 (and B2). Each clock pulse train consists of 256 pulses. The input clock frequency is higher than the display clock, in order to obtain the necessary timebase expansion.

Figure 5. The (prototype) front panel for the extended version of the TV scope gives a good idea of the facilities offered.

triggered is signified by a green LED, 'trig'd'.

Two signals can be displayed simultaneously on the TV scope: Y<sub>a</sub> and Y<sub>b</sub>. In some cases it will be useful to display them as two distinctly separate signals, side-by-side on the screen; at other times, it is more useful to have them overlapping so that minor differences can be evaluated — for instance, when comparing the input and output of an amplifier which is being driven to the verge of clipping. On the TV scope, the position of the two signals on the screen can be continuously varied between completely separate and exactly overlapping, by means of the control marked 'trace distance'. In essence, this control is a kind of synchronised Y-position control that affects both channels to an equal amount but in opposite directions.

The sensitivity of the TV scope is set by the controls marked 'volts/div'. On both input sections, the upper control is a multi-position switch and the lower is a fine control potentiometer. A switch next to the input socket offers a choice between AC and DC coupling. The Y-position control, as one would expect, sets the position of the trace along the Y-axis.

The circuit details, constructional hints and calibration procedure will be explained in detail next month. 

5

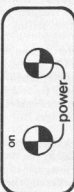
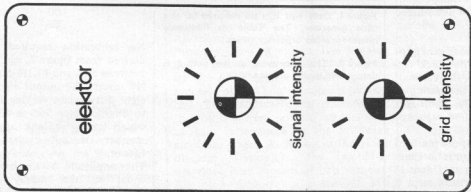
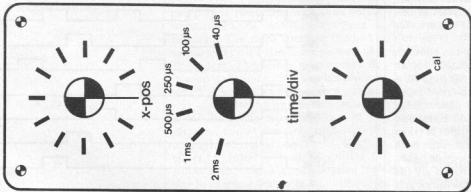
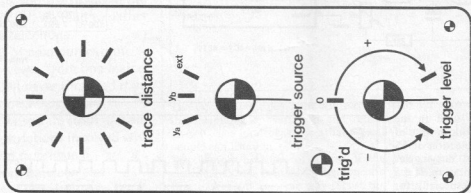
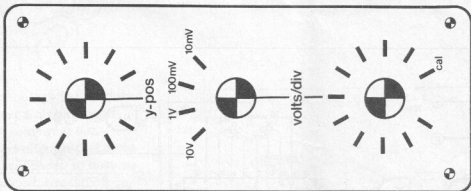
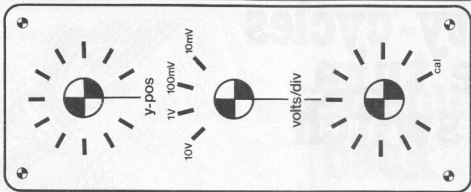



# 15 duty-cycles at the turn of a switch

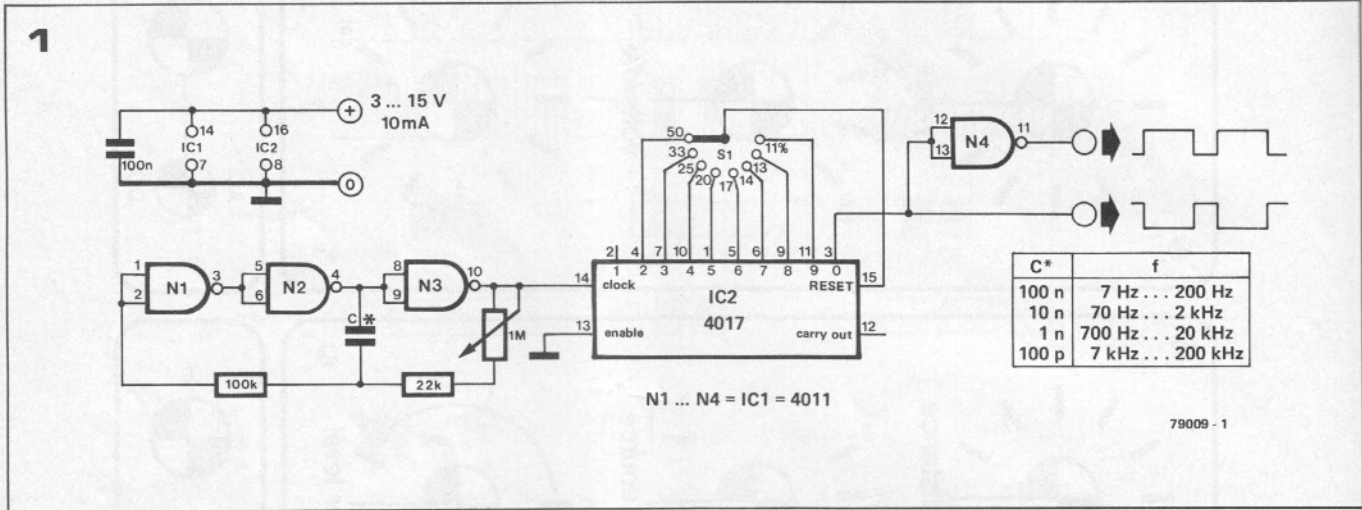

Only two CMOS-ICs are used in the generator described here, but in spite of its simplicity it offers a selection of 15 precisely determined duty-cycles without any need for calibration. It is a useful item of test gear, especially for calibrating other instruments that are designed to measure duty-cycles in one form or another — dwell meters, for instance.

The outputs of a divide-by-ten counter, the CD4017, are connected to an 8-position switch. One of the outputs is selected and fed back to the reset input of the IC. The result is a divider stage that can be set at any division ratio between 2 and 9. If the output is taken from the '0' output of the divider, both the frequency and the duty-cycle of the input frequency will be 'divided' by the preset ratio. Furthermore, the duty-cycle of the output signal will be independent of the input frequency: it is determined only by the setting of the selector switch.

To complete the unit, a clock generator is included (N1 ... N3). The 'clock' frequency is determined by the value of the capacitor, C, and by the setting of the 1 M potentiometer. The Table lists frequency ranges for a few capacitor values.

The duty-cycle at the output (pin 3 of IC2) is equal to the division ratio times 100%. For instance, if output '5' (pin 1) of IC2 is selected, the division ratio is 1:5 and the duty-cycle is

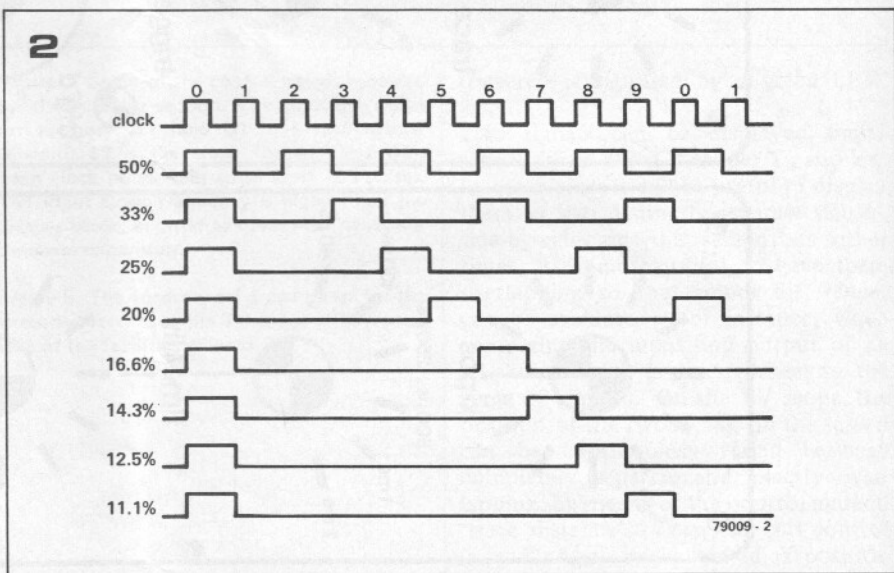

Figure 1. Only two IC's are required for this little generator. The Table lists frequency ranges for a few capacitor values.

Figure 2. The duty-cycle at the output is determined by the division ratio.

$$\frac{100}{5} = 20\%$$

No calibration required! As can be derived from figure 2, eight duty-cycles between 50% and 11.1% can be selected. N4 inverts the output signal, providing eight duty-cycles varying from 50% up to 88.9%. Since 50% is 50% no matter which way you look at it, the total number of duty-cycles available is fifteen.

The amplitude of the output signal is equal to the supply voltage, i.e. anywhere between 3 and 15 volts. ■



# hello, all you folks back home!

Modern technology has produced fast transport and centralised industry. A somewhat less desirable side-effect is that close relations have tended to become distant relations. Instead of gathering around the fire as in the 'good old days', we tend to gather around the telephone.

This means of communication suffers, however, from one major flaw: Ma Bell never intended it as a vital link between whole families. The system itself and all the legal restrictions involved with it are geared to private conversations between two individuals. The solution to the problem? A loudspeaking telephone.

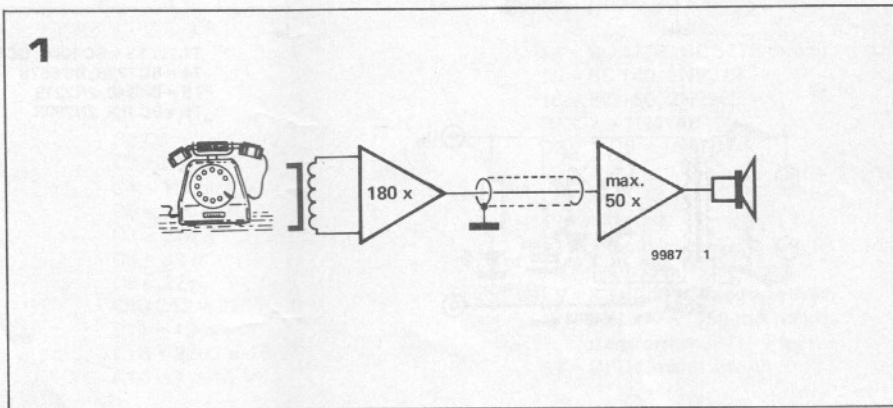

The circuit described here will pick up the telephone conversation and reproduce it via a loudspeaker, so that several people can listen in.

This is only possible, of course, if the electrical signals from the telephone are first picked up in some way. Since the Post Office, understandably, does not like people tampering with their wiring, some kind of indirect coupling is required. The most common method is to use a so-called telephone pick-up coil. This operates on a very simple principle: in every telephone there is a transformer which is wound and wired in a cunning way in order to route the incoming signal from the telephone line to the earpiece, and at the same time feed the microphone signal onto the line. In effect, it forms a kind of splitter for audio signals, with good coupling from line to earpiece and from microphone to line, but with poor coupling between the microphone and earpiece to avoid acoustic feedback.

All transformers have a stray field, and this one is no exception. If a suitable coil is placed in this field, it will 'pick up' the audio signals. Logically enough, a device of this kind is called a pick-up coil. The electrical signal delivered by the coil is extremely small, so that a lot of gain is required in the following amplifier stages. As shown in the block diagram (figure 1), the amplifier described here consists of two sections. The first section has a gain of 180 (45 dB). It can be connected via almost any length of single-core screened cable

to the second section, which has a gain of up to 50 (34 dB). This second stage drives the loudspeaker.

The advantage of cutting the circuit in two is that the first stage can be mounted quite near to the pick-up coil, minimising the amount of hum and interference picked up by the connecting wires. The bulk of the circuit, including loudspeaker and power supply, can be mounted at any suitable remote position.

Up to 50 m (160 ft) of screened cable can be used between the two stations — more than enough for any practical application we can imagine. The first section has no power supply of its own: it is powered from the main section via the connecting cable.

## The circuit

The complete circuit is shown in figure 2: figure 2a is the first stage, which is mounted near the pick-up coil; figures 2b and 2c are the second stage and the power supply, respectively.

The pick-up coil, L1, is a normal miniature choke and the value is not particularly critical. It is sometimes possible to obtain coils designed specifically for this purpose, mounted in a plastic capsule with a suction cup at one end. L1 and C1 together form a resonant circuit, but this is so heavily damped by R1 and the input impedance of T1 that the resonant peak is hardly noticeable — the main effect is to limit the bandwidth to a useful value.

The first stage would be a two-transistor

Figure 1. Block diagram of the telephone booster. The signal is picked up by a coil, since a direct connection into the telephone lines is not permitted. The booster itself consists of two sections, one mounted as close as possible to the phone and the other — much larger — section placed in any convenient spot.



2

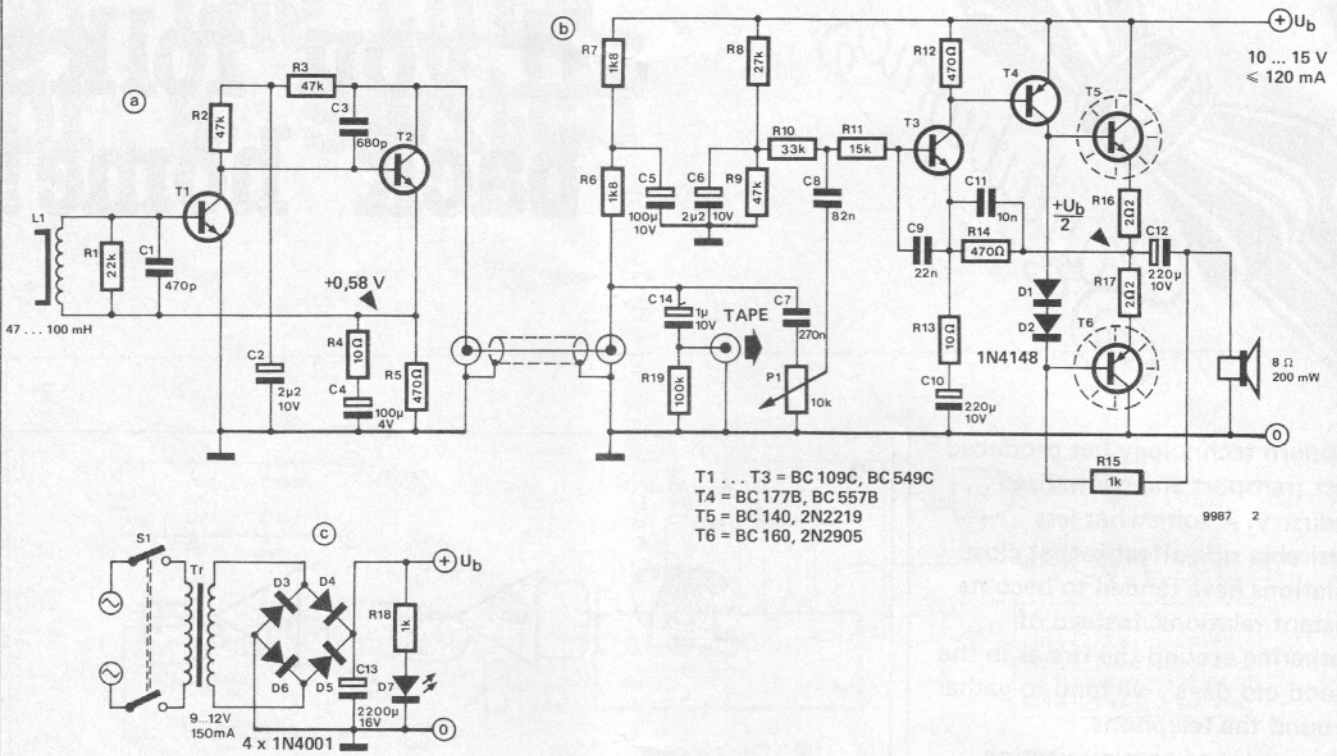

3a

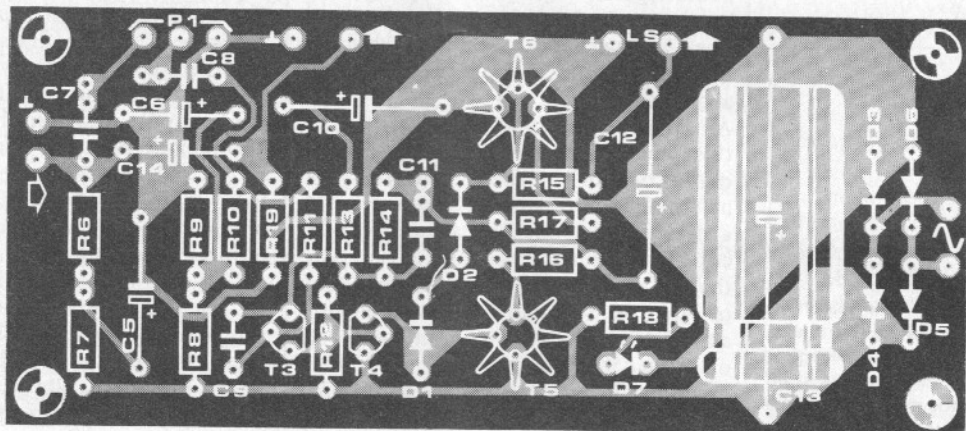
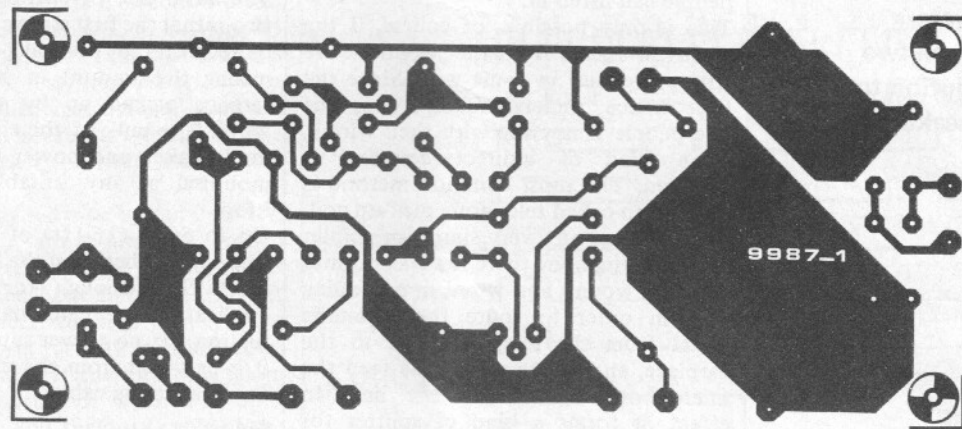

3b

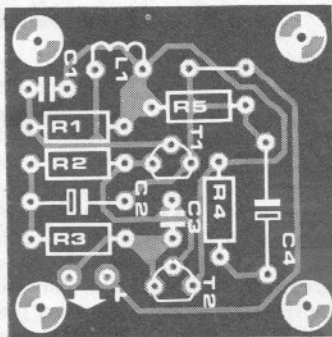
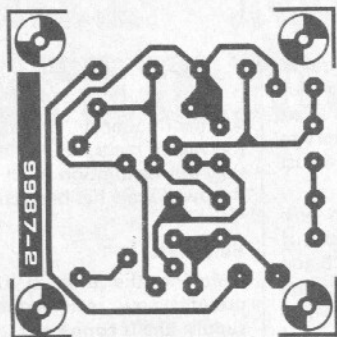

## Parts list

## Resistors:

R1 = 22 k  
 R2, R3, R9 = 47 k  
 R4, R13 = 10  $\Omega$   
 R5, R12, R14 = 470  $\Omega$   
 R6, R7 = 1k8  
 R8 = 27 k  
 R10 = 33 k  
 R11 = 15 k  
 R15 = 1 k $\Omega$   
 R16, R17 = 2 $\Omega$ 2  
 R18 = 1 k  
 R19 = 100 k  
 P1 = 10 k log.

## Capacitors:

C1 = 470 p  
 C2, C6 = 2 $\mu$ 2/10 V  
 C3 = 680 p  
 C4 = 100  $\mu$ /4 V  
 C5 = 100  $\mu$ /10 V  
 C7 = 270 n  
 C8 = 82 n  
 C9 = 22 n  
 C10, C12 = 220  $\mu$ /10 V  
 C11 = 10 n  
 C13 = 2200  $\mu$ /16 V  
 C14 = 1  $\mu$ /10 V

## Semiconductors:

T1, T2, T3 = BC 109C, BC 549C  
 or equ.  
 T4 = BC 177B, BC 577B or equ.  
 T5 = BC 140, 2N2219  
 T6 = BC 160, 2N2905  
 D1, D2 = 1N4148  
 D3... D6 = 1N4001  
 D7 = LED

## Miscellaneous:

L1 = miniature choke,  
 47... 100 mH, see text  
 LS = 8  $\Omega$ /200 mW loudspeaker  
 Tr = 9... 12 V/150 mA mains  
 transformer  
 S1 = DPDT mains switch

amplifier with a gain of 180, if T2 had a 1k8 collector resistor. Following the connecting cable, this resistor can indeed be located: R6 in figure 2b. This little trick, which was also used in the Preco, saves one wire: the same cable is used to feed the audio signal from the first section to the second and to supply power from the second section to the first. The output of the first section is basically a current source and can be loaded by a relatively low impedance, permitting the use of a fairly long cable. The second section is a 'bare-bones' design: only four transistors and a handful of other components are used in this little power amplifier. There is no quiescent current adjustment — that would be an unnecessary luxury for this application. On the other hand, no quiescent current at all would be the other extreme — the maximum gain would be lower. P1 is the volume control. A tape output is also provided, although it should be noted that — strictly speaking — the other party should be notified if the conversation is to be recorded.

The power supply (figure 2c) is straightforward. The only 'luxury' there is the LED, D7.

## Construction and use

Printed circuit board designs for the two sections are shown in figure 3. The main (figure 3b) contains both the second

section and the power supply. It is perhaps interesting to note that this board can also be used on its own as a low-cost, low-fi 'power' amplifier, provided R6, R7 and C5 are omitted. For that matter, the complete unit can also be used as a 'low-fi' public address installation...

Note that T5 and T6 should be provided with cooling fins or clips. There's no harm in them running 'warm', but they're not supposed to get 'hot'.

The two sections can each be mounted in their own case (even a tobacco tin will do for the first stage!) and connected by means of the desired length of cable. The pick-up coil should be connected to the first stage by the shortest possible length of twin-core screened cable: the two ends of the coil are connected to the two cores and the screening is connected to supply common.

The best position for the pick-up coil can be found by trial and error. When the handset is lifted off the hook, a dialling tone is obtained (if no dialling tone is heard, complain to the Post Office, not us) and the pick-up coil can now be moved, twisted and turned all over the telephone (*not* the handset) until this tone is reproduced at maximum strength by the loudspeaker. Note that both the position of the coil and the direction in which it is pointing will influence the 'reception'. Once the best position and location have been found, the coil can be fixed in position. 

Figure 2. The complete circuit. Figure 2a is the first section, which is connected by means of single-core screened cable to the second section, shown in figure 2b. The power supply, figure 2c, can also be mounted in the main station.

Figure 3. The two p.c. boards required. The larger of the two (figure 3a), EPS 9987 - 1, is for the main station including power supply; the second is for the first section of the circuit (EPS 9987 - 2).



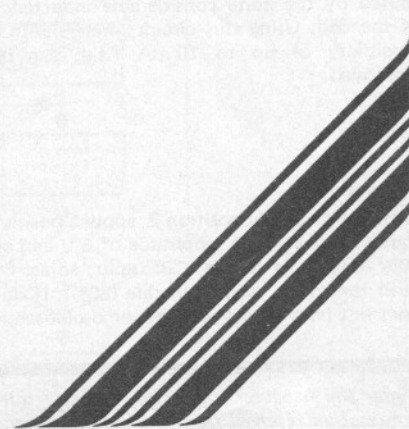

# APLIKATOR

## R.P.M. and dwell meter using a window discriminator, the TCA 965.

This interesting circuit appeared as 'Circuit of the day' in the Siemens Components Report no. 2/78.

The circuit is easy to construct and calibrate, it will operate over a wide range of supply voltages (8...20 V), and it is quite accurate. It is also ideally suitable for use in cars, since it is insensitive to temperature variations over a wide range and has high noise immunity.

Figure 1 shows the complete circuit, using a 1 mA instrument (a modification for more robust 10 mA instruments will be discussed later). With the switch in position 1 the circuit operates as a rev. counter. The input (CB) is connected to the contact breaker; R2, D3 and C2 provide protection against high voltage transients. When the contact breaker opens, the voltage at the input rises; as soon as the voltage at pin 6 exceeds the trigger voltage at pin 8 (i.e. 3 V, derived from the reference output, pin 5), the open-collector output at pin 13 is turned on for a period set by R3 and C5. During this set period, current therefore flows through the 1 mA instrument. This current is made virtually independent of supply voltage fluctuations by the simple expedient of deriving it from a second reference output, pin 10. The mechanical inertia of the meter is sufficient to integrate the current pulses, resulting in the desired RPM indication.

With the switch in position 2, the circuit operates as a dwell meter. Basically, it merely 'cleans up' the pulses from the contact breaker: as long as the latter is closed, current flows through the meter. As before, the inertia of the meter itself is sufficient to average-out the pulses — producing the desired reading.

The choice of component values shown is such that the same scale can be used for both measurements. In switch position 1, full scale corresponds to 8000 RPM. In position 2 (dwell), the meter will read full scale for an 80% duty-cycle (contact closed for 80% of the time).

It is common practice in automobile electronics to use heavily-damped and relatively insensitive instruments with a 270° scale. For instruments of this type, the circuit modifications shown in figure 2 are required. D5 and D6 compensate the relatively large temperature coefficient of the instrument, and D7 protects the IC from reverse-voltage spikes caused by the quite considerable inductance of the coil. Using this circuit, meters with a sensitivity of up to 10 mA f.s.d. can be employed.

### Calibration

With the switch in position 2, apply a positive square-wave with an amplitude of 5 V and an 80% duty-cycle to the 'CB' input; adjust P1 until the meter reads full-scale (80%). If one does not have access to either an oscilloscope

or an accurately calibrated pulse generator, the generator described elsewhere in this issue ('15 duty-cycles at the turn of a switch') will prove useful. Alternatively, one can resort to a normal, symmetrical square-wave and adjust P1 until the meter reads 50%.

For the RPM measurement (switch in position 1), calibration is not really necessary. If 5% tolerance components are used for C5 and R3, the reading will be sufficiently accurate for most practical purposes. The correct value of R3 depends on the number of cylinders (c) and the 'number of strokes' (s), as follows:

$$R_3 = \frac{s}{c} \times 40 \text{ (k}\Omega\text{)}.$$

To give a few examples: for a four-cylinder four-stroke engine, R3 would be 40 k (use 39 k); for a 6 cylinder 4-stroke the correct value is 27 k.

Of course, if a pulse generator and a frequency counter are available, exact calibration is possible. R3 is replaced by a suitable preset potentiometer (50 k will be correct in most cases), and a square-wave of sufficient amplitude is applied to the CB input. The frequency is determined by the number of cylinders and 'strokes', as follows:

$$f = \frac{c}{s} \times 266 \text{ Hz.}$$

At this frequency, the preset is adjusted until the meter reads full scale (8000 RPM). Note that this calibration must be carried out **after** the dwell scale has been correctly calibrated!

### Final notes

Installing the unit in the car should not present any real problems. The positive supply line is connected to the 12 V supply in the car at some (fused) point after the ignition switch — the connection for a car radio or cigarette lighter is usually a good point — and the 'supply common' connection is taken to the bodywork of the car at some convenient point near the meter (Note that the circuit is not intended for use in cars with positive ground!). Finally, the CB input is connected to the lead between the ignition coil and the contact breaker.

To avoid excessive interference problems, it is advisable to run the lead to the CB input as close to the metalwork of the car as possible for the whole of its length — keeping away from 'hot spots' of course! Better still, screened cable can be used, with the screen connected (at one end only!) to the bodywork of the car.

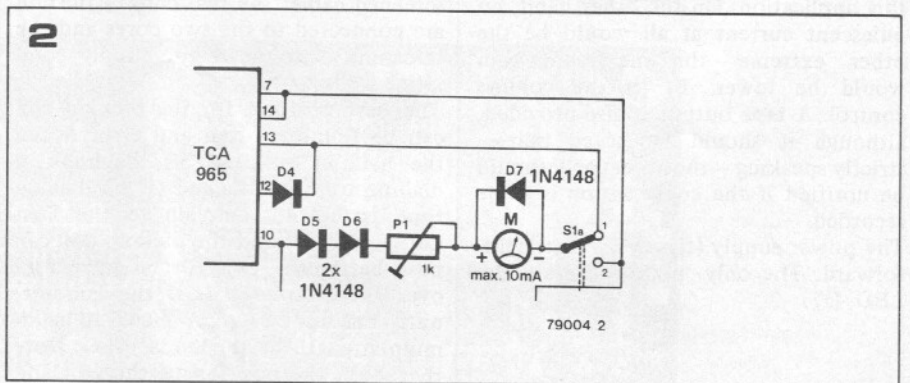
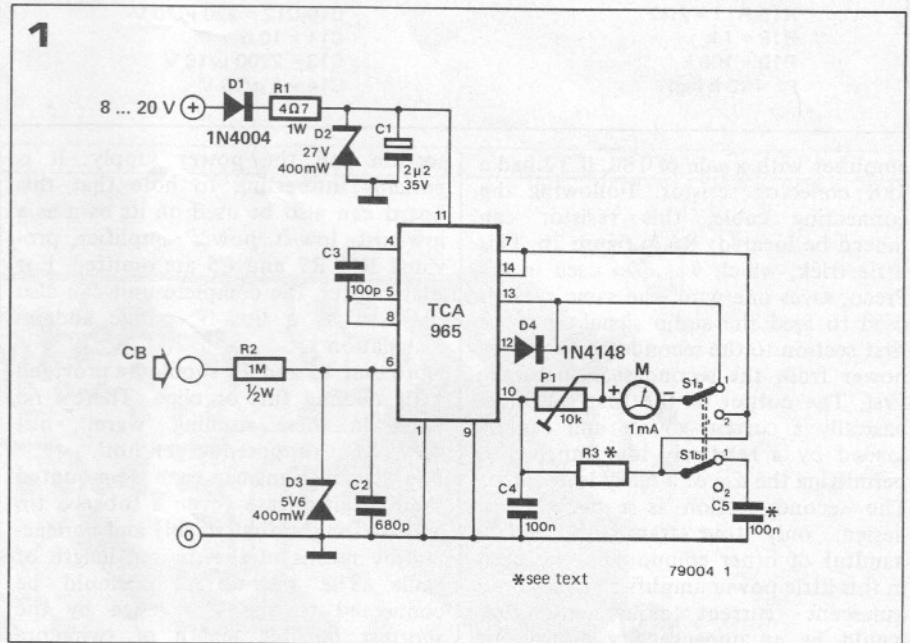

# SC/MP 'Mastermind'™ programme

Pit your wits against the computer with the aid of the following 'Mastermind'™ programme, which is designed to run on the Elektor SC/MP system.

F. Schuldt

Figure 1. This flow-diagram should help to clarify the operation of the 'compare' routine.

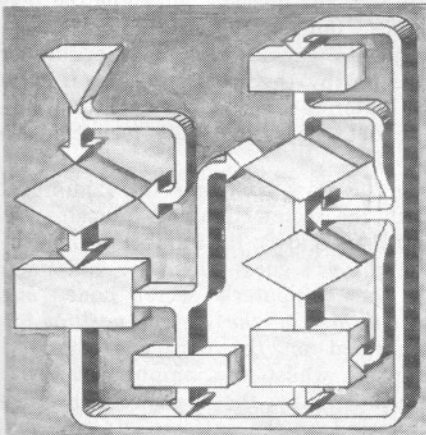

1

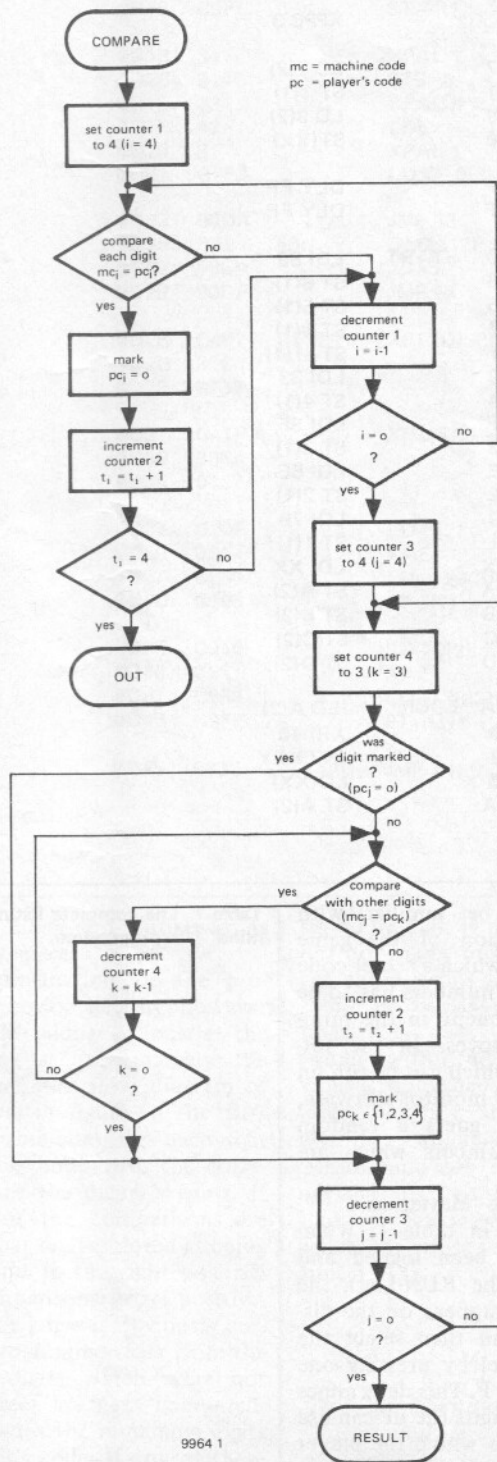



Table 1

0C00	C46D	ENTER:	LDI 6D	0C5D	AA0B		ILD B(2)
0C02	C906		ST 6(1)	0C5F	E410		XRI 10
0C04	C479		LDI 79	0C61	9C18		JNZ KEY
0C06	C905		ST 5(1)	0C63	C0E6		LD(XX)
0C08	C478		LDI 78	0C65	CA0B		ST B(2)
0C0A	C904		ST 4(1)	0C67	AA0C		ILD C(2)
0C0C	C400		LDI 00	0C69	E410		XRI 10
0C0E	C903		ST 3(1)	0C6B	9C0E		JNZ KEY
0C10	C902		ST 2(1)	0C6D	C0DC		LD(XX)
0C12	C901		ST 1(1)	0C6F	CA0C		ST C(2)
0C14	C440		LDI 40	0C71	AA0D		ILD D(2)
0C16	C900		ST 0(1)	0C73	E410		XRI 10
0C18	C471		LDI 71	0C75	9C04		JNZ KEY
0C1A	C9FF		ST-1(1)	0C77	C0D2		LD(XX)
0C1C	C455		XP3 (PUSH) - 1	0C79	CA0D		ST D(2)
0C1E	33C4			0C7B	C108	KEY:	LD 8(1)
0C20	0037			0C7D	94D4		JP LOOP
0C22	3F		XPPC 3	0C7F	C400		LDI 00
0C23	C207		LD 7(2)	0C81	CA0E		ST E(2)
0C25	C901		ST 1(1)	0C83	C43E	NEXT:	LDI L(GETHEX)-1
0C27	C209		LD 9(2)	0C85	CA1D		ST 1D(2)
0C29	C820		ST(XX)	0C87	C455		XP3(PUSH)-1
0C2B	8FFF		DLY FF	0C89	33C4		
0C2D	8FFF		DLY FF	0C8B	0037		
0C2F	C480	START:	LDI 80	0C8D	02		CCL
0C31	C906		ST 6(1)	0C8E	C401		LDI 01
0C33	C905		ST 5(1)	0C90	EA0E		DAD E(2)
0C35	C900		ST 0(1)	0C92	CA0E		ST E(2)
0C37	C9FF		ST-1(1)	0C94	3F		XPPC 3
0C39	C439		LDI 39	0C95	C400		LDI 00
0C3B	C904		ST 4(1)	0C97	CA0F		ST F(2)
0C3D	C43F		LDI 3F	0C99	CA10		ST 10(2)
0C3F	C903		ST 3(1)	0C9B	903A		JMP COMP
0C41	C45E		LDI 5E	0C9D	9090	JS:	JMP START
0C43	C902		ST 2(1)	0C9F	C41F	OUT:	XP3(TAB)-1
0C45	C479		LDI 79	0CA1	33C4		
0C47	C901		ST 1(1)	0CA3	0137		
0C49	C4XX		LDI XX	0CA5	C20E		LD E(2)
0C4B	CA0A		ST A(2)	0CA7	D40F		ANI 0F
0C4D	CA0B		ST B(2)	0CA9	01		XAE
0C4F	CA0C		ST C(2)	0CAA	C380		LD-128(3)
0C51	CA0D		ST D(2)	0CAC	C9FF		ST-1(1)
0C53	AA0A	LOOP:	ILD A(2)				
0C55	E410		XRI 10				
0C57	9C22		JNZ KEY				
0C59	C0F0		LD(XX)				
0C5B	CA0A		ST A(2)				

Most readers will be familiar with one or other variation of the game 'Mastermind'™, in which a secret code of colours, letters or numbers has to be 'broken' by an opponent in the minimum number of moves. In the following programme, which can be run on a SC/MP with 'Elbug' monitor software, the player has to guess a random sequence of four numbers which are generated by  $\mu$ P.

The full listing of the 'Mastermind'™ programme is given in table 1. When the programme has been loaded and started (by hitting the RUN-key), the text 'set -F' should appear on the displays. The player can then select the desired difficulty level by pressing one of the keys from 4 to F. This determines which hexadecimal digits the  $\mu$ P can use to make up the code which the player has to break. If, for example, the key

Table 1. The complete listing for the 'Mastermind'™ programme.

'9' is pressed, then the code 'word' may consist of a combination of any four digits between 9 and F (i.e. 9, A, B, C, D, E, or F).

Once the desired data key has been pressed, the displays will show the text 'code', indicating that the player can begin to guess the four-digit number selected by the computer. This is done by entering four (legal) numbers from the data keys, these are registered on the displays.

The  $\mu$ P now compares these numbers with the secret code and indicates the result as follows: the number of digits in the player's guess which are contained in the computer's secret code, *but which are in the wrong position*, is registered on the extreme right-hand display, whilst the number of digits which occupy the correct position is indicated on the extreme left-hand dis-

Table 1, cont.

0CAE	C20E		LD E(2)	0D03	C501		LD @+1(1)
0CB0	1C1C		SR	0D05	01		XAE
0CB2	1C1C		SR				
0CB4	01		XAE	0D06	C1F8		LD-8(1)
0CB5	C380		LD-128(3)	0D08	9809		JZ \$5
0CB7	C900		ST 0(1)				
				0D0A	40	\$4:	LDE
0CB9	C479		LDI 79	0D0B	E701		XOR @+1(3)
0CBB	C906		ST 6(1)	0D0D	9C16		JNZ \$6
0CBD	C437		LDI 37				
0CBF	C905		ST 5(1)	0D0F	AA10		ILD 10(2)
0CC1	C45E		LDI 5E	0D11	CBFF		ST-1(3)
0CC3	C904		ST 4(1)				
0CC5	C400		LDI 00	0D13	BA00	\$5:	DLD 0(2)
0CC7	C901		ST 1(1)	0D15	9814		JZ RESULT
0CC9	C902		ST 2(1)				
0CCB	C903		ST 3(1)	0D17	C1F8		LD-8(1)
				0D19	C9FC		ST-4(1)
0CCD	C108	WAIT:	LD 8(1)				
0CCF	94FC		JP WAIT	0D1B	31		XPAL 1
0CD1	8FFF		DLY FF	0D1C	0140		STE
0CD3	90C8		JMP JS	0D1E	33		XPAL 3
				0D1F	40		LDE
0CD5	90AC	JN:	JMP NEXT	0D20	31		XPAL 1
				0D21	C7FA		LD @-6(3)
0CD7	C4E7	COMP:	XP3(STKBSE)+7				
0CD9	33C4			0D23	90DA		JMP \$3
0CDB	0F37			0D25	BA01	\$6:	DLD 1(2)
				0D27	98EA		JZ \$5
0CDD	C404		LDI 04	0D29	90DF		JMP \$4
0CDF	CA00		ST 0(2)				
				0D2B	C401	RESULT:	XP1 (DISPL)+1
0CE1	C7FF	\$1:	LD @-1(3)	0D2D	31C4		
0CE3	E307		XOR 7(3)	0D2F	0735		
0CE5	9C08		JNZ \$2				
				0D31	C41F		XP3(TAB)-1
0CE7	CB00		ST 0(3)	0D33	33C4		
0CE9	AA0F		ILD F(2)	0D35	0137		
0CEB	E404		XRI 04				
0CED	98B0		JZ OUT	0D37	C20F		LD F(2)
				0D39	01		XAE
0CEF	BA00	\$2:	DLD 0(2)	0D3A	C380		LD-128(3)
0CF1	9CEE		JNZ \$1	0D3C	C906		ST 6(1)
				0D3E	C210		LD 10(2)
0CF3	C701		LD @+1(3)	0D40	01		XAE
0CF5	C4EA		XP1(STKBSE)+A	0D41	C380		LD-128(3)
0CF7	31C4			0D43	C9FF		ST-1(1)
0CF9	0F35						
				0D45	908E		JMP JN
0CFB	C404		LDI 04				
0CFD	CA00		ST 0(2)				
0CFF	C403	\$3:	LDI 03				
0D01	CA01		ST 1(2)				

play. On the basis of this information, the player then enters a second number, whereupon the  $\mu P$  will respond in a similar fashion, indicating how many digits are correct and how many are in the right place etc. This continues until the player finally guesses the secret code, at which point the text 'End XX' will appear on the displays, the number XX indicating how many attempts the player took to guess correctly. The game can be restarted by pressing one of the data keys. If the difficulty level is to be modified, the game must be restarted with the 'Run' key.

### Compare routine

As already mentioned, the 'Mastermind'™ programme can only be run on a system with 'Elbug' monitor software. This is because the programme

utilises several Elbug sub-routines so as to save memory space.

A complete explanation of the programme would be too lengthy, however it is worthwhile taking a look at the most interesting section, namely the compare routine, the flow diagram of which is shown in figure 1. The first part of this routine compares each digit of the computer code with the corresponding digit of the player's guess. If one or more of the comparisons are positive, then that digit is noted as being both correct and in the right position (if all four comparisons prove positive, then the player's guess is obviously correct, and the programme exits from the routine). The digits which were not marked as correct are next compared, one at a time, with the remaining digits of the computer's code. If any of these comparisons proves positive, the corre-

sponding digit is noted as being correct, but not in the proper position. When all the comparisons are complete, the final result is displayed via the Elbug routines.

Along with those programmes previously published ('reaction timer' and 'digital clock'), and a number of programmes which are still to appear, 'Mastermind'™ will also be available on the disc to be produced by the Elektor Software Service (see the article on this subject in Elektor 38, June 1978).

*TM We acknowledge the fact that 'Mastermind' is a registered trade mark of Invicta Plastics Ltd., Oadby, Leicester.*





# pocket bagatelle

An electronic version of the age-old dexterity game.

Many traditional games, which have been passed on unchanged from generation to generation, can now be simulated electronically (see, e.g. 'Marbles' in Elektor 21, January 77). In particular, 'video' games, which utilise the screen of a TV set to represent the field of play, have achieved enormous popularity in recent years, and with the advent of more and more complex 'games chips', this trend shows little sign of slowing down. However there are still many electronic versions of popular games which can be played without recourse to a TV set. One of the more simple (but not necessarily easy!) games, which is ideally suited as a small Christmas present, is 'bagatelle'.

There are several variations of the game 'bagatelle'; the one described here belongs to the species of manual dexterity games which are designed to test a steady hand, strong nerves and infinite patience. The original and simplest version of the game consists of a round flat container with a transparent top, inside which a small ball rolls around.

The object of the game is to manoeuvre the ball into a shallow hole set into the bottom of the container. However, since the ball is very small and light, and both it and the surface over which it rolls are extremely smooth and have a very low coefficient of friction, it is extraordinarily difficult to control the direction in which the ball will move, or indeed to hold it steady at any one point. Furthermore, the hole itself is quite shallow, and very little is needed to make the ball jump back out.

This fact is particularly annoying if one has a more complicated version of the game with two or more balls to be manoeuvred into two or more holes. It is quite amazing how many times one can manipulate one ball into its hole and be just on the point of succeeding with the second, when the first ball suddenly pops back out. Grown men have been seen to weep with frustration! With Christmas not too far away, the following circuit for an electronic version of this tantalising game may help to solve that perennial problem of choosing presents — especially as far as younger relatives are concerned.

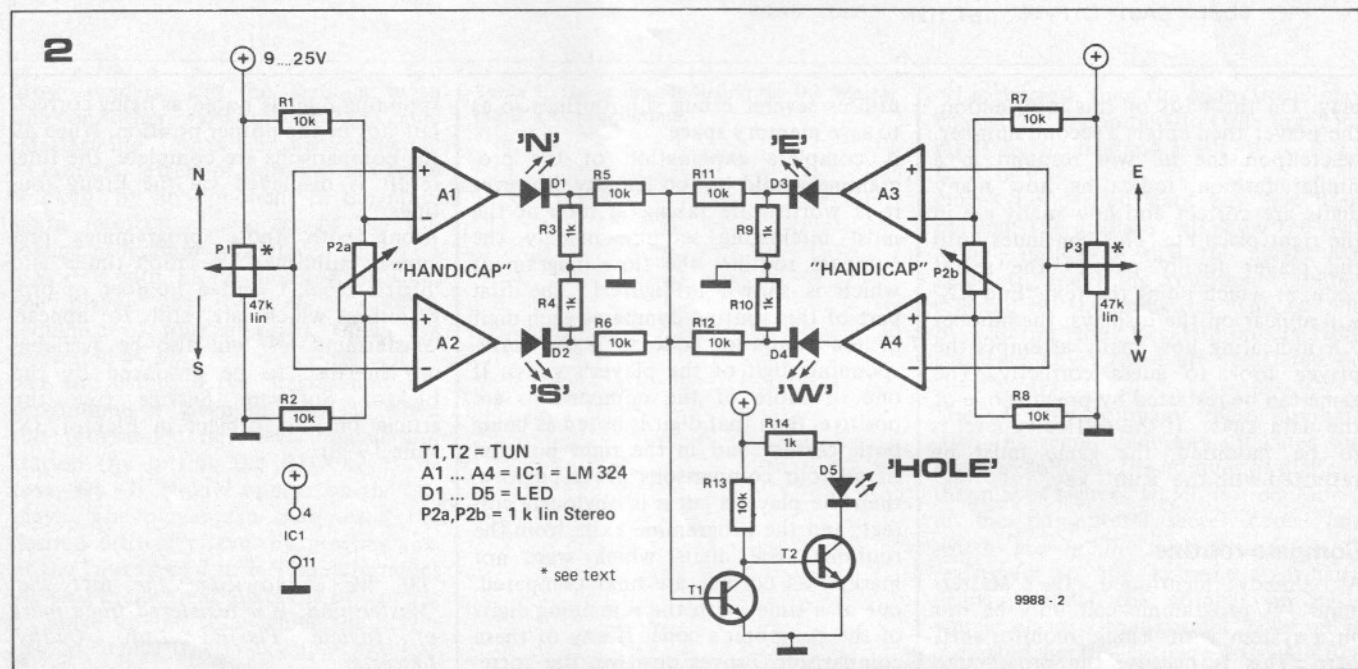
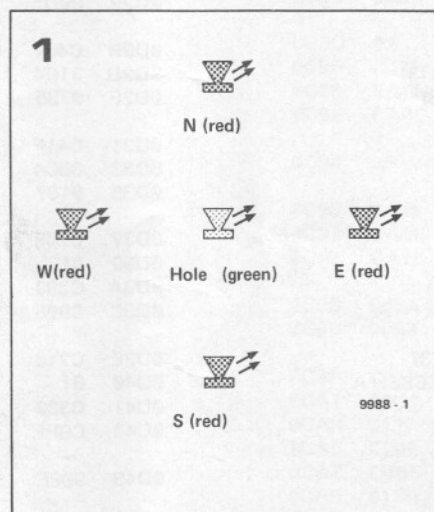

The game is played as follows: a single 'ball', whose position is indicated by four LEDs, has to be manoeuvred into a central 'hole' represented by a LED of a different colour. The arrangement of the LEDs is shown in figure 1. The 'ball', which in fact does not physically exist, can be 'rolled' in two directions: north-south and east-west. The four LEDs, one at each of the compass points, indicate whether the ball is to the north, south, east or west of the 'hole'. The position of the ball is controlled by two potentiometers, one for each direction. When the ball has been successfully manoeuvred into the 'hole', the central LED lights up and the other four LEDs are all extinguished. The degree of difficulty of the game, as it were the 'size of the hole', can be varied by means of a third, 'handicap' potentiometer.

### The circuit

The electronics of the game are revealed in the circuit diagram of figure 2. The circuit basically consists of the two window comparators formed by A1/A2 and A3/A4. To help explain how this type of circuit works, the basic circuit diagram of a window comparator is shown in figure 3. As can be seen, the circuit has a single input signal,  $u_i$ , and two output signals,  $u_1$  and  $u_2$ . Op-amps A1 and A2 are connected as comparators, i.e. due to the absence of feedback, their outputs are always in one of two states: either high or low. When the voltage at the non-inverting (+) input of a comparator is greater than that at the inverting (-) input, the output voltage of the device swings up to + supply. However if the voltage on the inverting input is greater than that at the non-inverting input, then the output of the comparator swings down to - supply, in this case, to ground.

One of the inputs of each comparator shown in figure 3 is connected to a constant reference voltage. These reference

Figure 1. The board of the 'pocket bagatelle' contains five LEDs. The middle (green) LED lights up when the player succeeds in rolling the ball into the hole. The other four (red) LEDs indicate the position of the ball relative to the hole.

Figure 2. The complete circuit diagram of the pocket bagatelle, which is based on two window comparators.

Figure 3. The basic circuit of a window comparator.

Figure 4. This figure shows how the two output voltages of the comparators,  $u_1$  and  $u_2$ , vary with the input voltage,  $u_i$ .

voltages,  $U_a$  and  $U_b$ , are derived from an attenuator network, consisting of R1, R2 and P. Depending upon the value of the input voltage,  $u_i$ , one of three possible situations can occur:

- $u_i$  is greater than  $U_a$ , in which case  $u_1$  will be high and  $u_2$  low.
- $u_i$  is smaller than  $U_b$ , in which case  $u_2$  will be high and  $u_1$  low.
- $u_i$  lies between  $U_a$  and  $U_b$ , in which case both  $u_1$  and  $u_2$  will be low.

When this occurs, the input voltage,  $u_i$ , can be said to lie 'inside the window'. The height of the window can be varied by means of potentiometer P.

These three situations are illustrated by the diagram of figure 4, which shows how the outputs of the two op-amps react to a rising input voltage.

Two such window comparators are employed in the circuit of the pocket bagatelle. The input of each is derived via a potentiometer, these being P1 and P3 respectively. P1 controls the vertical position of the ball, whilst P3 varies the horizontal position. Each of the outputs of the two window comparators drives an LED; it is clear from figure 4 that each output voltage goes high when the input voltage of the window comparator lies on that 'side' of the window. With two window comparators, whose input voltages represent the horizontal and vertical position of the 'ball' (and whose windows intersect) it is obvious that the logic state of the comparator outputs, and hence the on/off state of the corresponding LEDs, tell us whether or not the 'ball' has 'rolled' to a given side of the 'hole'. If all four 'pointer' LEDs are extinguished, the centre LED will come on indicating that the player has succeeded and the ball has been manoeuvred into the hole.

The LEDs are driven directly by the outputs of the comparators; the current through the LEDs is limited by a series resistor. The voltage across this resistor is also used to turn on T1. This transistor will remain conducting as long as one of the LEDs D1...D4 is lit. If all four LEDs are extinguished, however, T1 will turn off, causing T2 to turn on, and the green central LED, D5, to light up.

The dimensions of the window, and hence the difficulty level of the game, can be varied by means of stereo potentiometer P2ab.

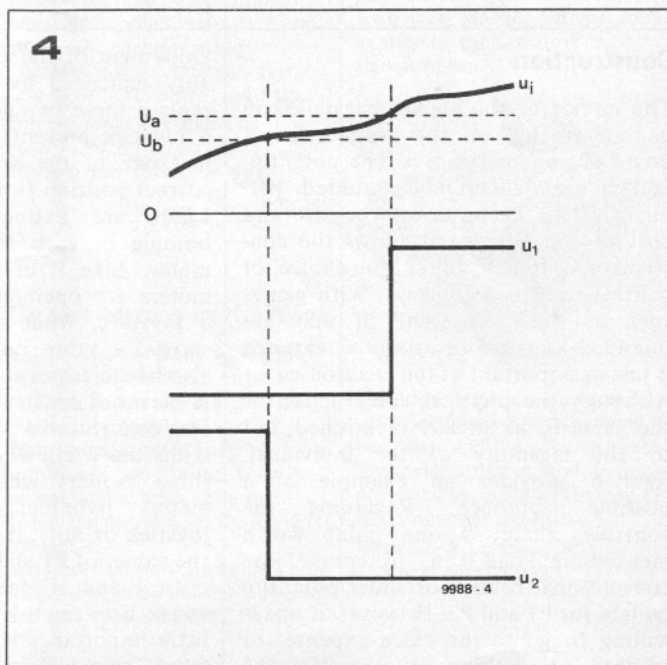
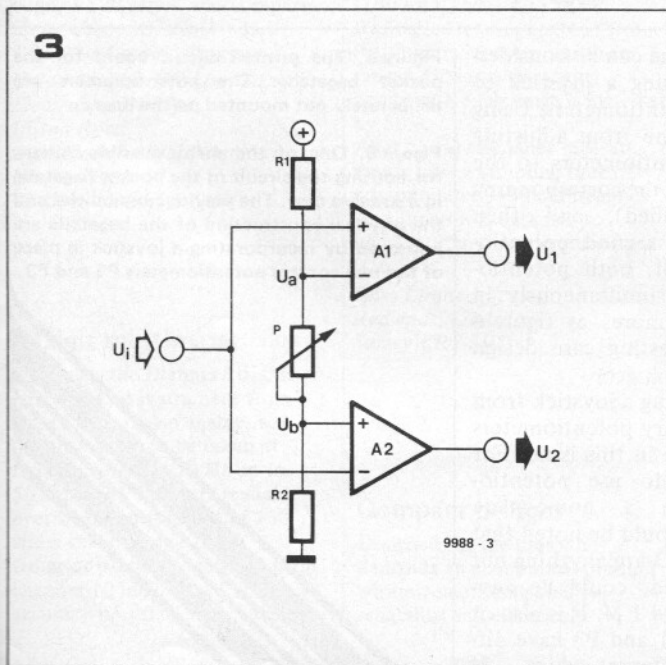



5

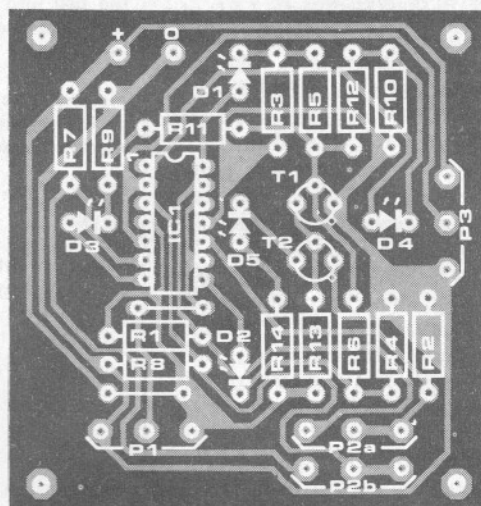
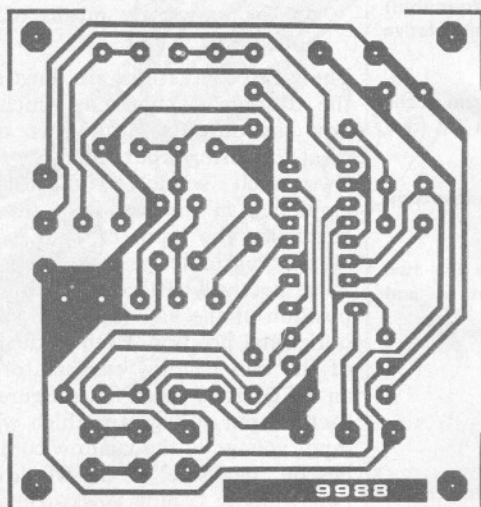

## Parts list

## Resistors:

R1, R2, R5 . . . R8,  
 R11, R12, R13 = 10 k  
 R3, R4, R9, R10, R14 = 1 k  
 P1, P3 = 47 k (50 k) lin  
           potentiometer  
 P2ab = 1 k lin  
           stereo potentiometer

## Semiconductors:

IC1 = LM 324  
 T1, T2 = TUN  
 D1 . . . D4 = LED red  
 D5 = LED green

6

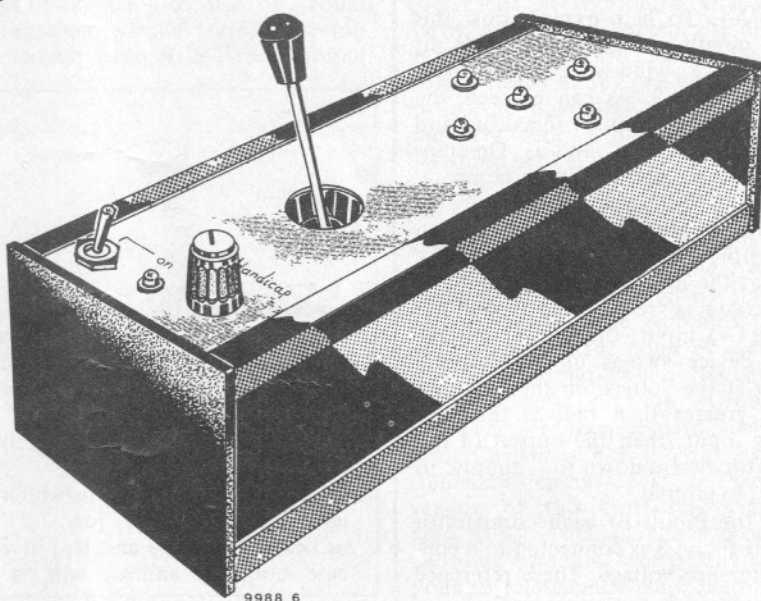

## Construction

The circuit of the pocket bagatelle can be constructed on the printed circuit board shown in figure 5. The potentiometers are deliberately mounted 'off-board'. This keeps down the size and cost of the board and allows the constructor a free hand in the choice of controls and type of case. With games such as these, especially if they are intended as gifts, an attractive exterior is just as important as the electronics.

Although the physical construction of the game is, as already mentioned, left to the ingenuity of the individual, figure 6 provides an example of a possible approach. Regarding the controls, there is one point worth mentioning: one can, of course, use conventional rotary- or slider potentiometers for P1 and P3. However, if one is willing to go to the extra expense (or trouble of making it oneself), the

enjoyment of the game can be considerably enhanced by using a joystick to replace these two potentiometers. Using a joystick prevents one from adjusting just one of the potentiometers to the correct position (until the corresponding LEDs are extinguished), and then homing in with the second potentiometer. Like it or not, both potentiometers are operated simultaneously in a joystick. What is more, as figure 6 shows, a more interesting case design also becomes possible.

A means of constructing a joystick from two conventional rotary potentiometers is discussed elsewhere in this issue. For those readers who do use potentiometers (whether in a home-made joystick or not), it should be noted that the values of P1 and P3 are anything but critical and if needed, could lie anywhere between 1 k and 1 M. It is also of little importance if P1 and P3 have different, even widely different values. ◀

Figure 5. The printed circuit board for the pocket bagatelle. The potentiometers are deliberately not mounted on the board.

Figure 6. One of the many possible designs for housing the circuit of the pocket bagatelle in a suitable case. The playing possibilities and the physical construction of the bagatelle are improved by incorporating a joystick in place of the two control potentiometers P1 and P3.

# MARKET

## Subminiature Tantalum capacitors

A new series of Kemet subminiature axial-leaded tantalum capacitors in a high precision epoxy moulding has been launched by Union Carbide UK Limited Electronics Division. Designated the T 322 series, it is designed for high speed automatic insertion applications as the four case sizes correspond to standard resistor and diode sizes. These capacitors offer an extremely high volumetric efficiency and include among their applications decoupling, blocking, bypassing and filtering in computers, data processing, communications and other electronic equipment.

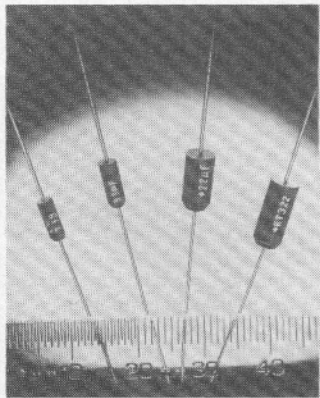

Electrical ratings extend from  $68 \mu\text{F}/6 \text{ V}$  through  $4.7 \mu\text{F}/50 \text{ V}$ . The temperature range spans  $-55^\circ\text{C}$  to  $+85^\circ\text{C}$  (or to  $+125^\circ\text{C}$  with voltage derating). The T 322 series replaces the T 320 series of epoxy moulded tantalums and metal-cased types. Prices for the new series are significantly lower than for the larger T 320 series, and compare favourably with the standard T 310 axial-moulded type.

*Union Carbide UK Limited, Electronics Division, Hilton Road, Aycliffe Industrial Estate, Nr. Darlington, Co Durham DL5 DL6*

(919 M)

## 4 Digit multimeter

Known as the Digimer 10, this new portable instrument from Iskra Limited also enables a.c. measurements to be taken at frequencies from 20 Hz up to 50 kHz. The digits are readable over a horizontal angle of  $150^\circ$ , and a vertical angle of  $90^\circ$ . Other outstanding features of the Digimer 10 include: 17 ranges, an accuracy of  $\pm 0.05\%$ ,  $\pm 1$  digit;

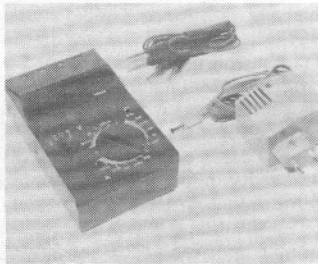

automatic polarity indication; a selection of optional shunts for measuring higher currents; and rechargeable nickel-cadmium batteries that power the multimeter for eight hours between charging operations. In addition, the Digimer 10 can be used while connected to an optional battery charger, except when measuring parameters involving voltages above 1000 volts. Carefully designed to maximise ease of use, the Digimer 10 has a 7-segment LED display. The figures are 7.62 mm high, and the display is angled for optimum readability when used on a flat surface. Only two controls provide instant range switching to any one of the 17 ranges.

A built-in over-ranging trip circuit allows safe operation on all ranges up to 50% above full-scale deflection value. The unit features integral automatic drift compensation and overload protection. Voltage ranges (a.c. and d.c.) have a high degree of resolution, which is given in brackets after each full-scale deflection: 200 mV (0.1 mV), 2 V (1 mV), 20 V (10 mV), 200 V (100 mV), and 2000 V (1 V).

Current ranges (a.c. and d.c.) and their resolutions are: 20  $\mu\text{A}$  (10 nA), 200  $\mu\text{A}$  (100 nA), 2 mA (1  $\mu\text{A}$ ), 20 mA (10  $\mu\text{A}$ ), 200 mA (100  $\mu\text{A}$ ), and 2 A (1 mA). Resistance readings extend from 0.1 ohm to 20 megohms in six ranges. Under over-ranging conditions, each range is increased by 50%.

All d.c. and resistance measurements have a sampling time of approximately 300 milliseconds. And the unit is designed to operate at any temperature from 0 to  $55^\circ\text{C}$ .

*Iskra Limited, Redlands, Coulsdon, Surrey CR3 2HT.*

(929 M)

## Compact bridges

Designed for the user who demands an economical product without sacrificing quality, reliability and electrical

performance. International Rectifier announce the introduction of a range of small single phase bridge rectifiers.

Coded 1 KAB, the series has current rating of 1.2 A into a resistive load, and 1.0 A if the load is capacitive.

Correct mounting orientation is ensured by the use of a  $9.5 \times 9.5 \times 8.0 \text{ mm}$  polarised package, which is particularly useful when checking load identification on densely populated PCB assemblies. The leads are on a standard 2.54 mm grid.

The range is equivalent to the B...C1000 series of DIN bridges and may also be used as superior replacements for the B...C500 and B...C800 devices.

The 1 KAB is offered over the voltage range 100 to 1000 V VRRM. The product data sheet gives useful application information and a cross reference to the DIN types, as well as full details of the device specification.



Typical applications would be in general purpose power supplies, auxiliary supplies in power equipment, low current battery chargers, communications systems and the entertainment industry.

*International Rectifier Co., (G.B.) Ltd., Hurst Green, Oxted, Surrey.*

(923 M)

## Circuit testing in the open

Testing circuits while your equipment is in operation is at best difficult and at worst impossible. To ease the problem Vero Electronics Limited have introduced two Eurocard compatible extender boards to complement the Vero Eurocard System 4.

They are 100 mm wide x 263 mm long - one carries 64/64-way plug and socket to DIN 41612, the

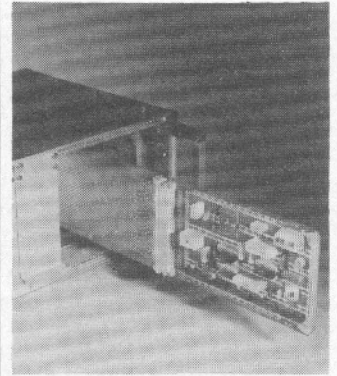

other a 64/96-way plug and socket.

Included in the kit with each board are 20 terminals that can be assembled into pre-drilled holes in the board for test points. Both boards are manufactured from Epoxy Glass.

*Vero Electronics Limited, Industrial Estate, Chandler's Ford, Eastleigh, Hampshire. S05 3ZR.*

913 M)

## New hyreg module

Westcode Semiconductors of Chippenham announce a new addition to their popular range of Hyreg module units.

Called the IPT 1/250-25, a single-phase basic ac regulator module, it has been developed to control loads of up to 6.25 kW from a mains supply and features a 10 mSec surge rating of over 210 amperes.

The high overcurrent and  $I^2 t$  ratings make this unit especially attractive for the control of loads with heavy starting currents such as stage lighting, motors or transformers.

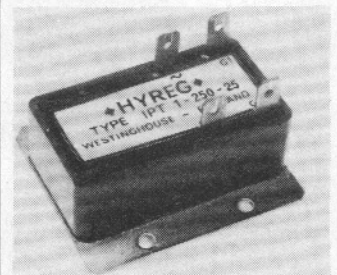

This module employs a ceramic substrate bonded to an isolated base plate and the whole is potted to provide a rugged module fully protected against a wide range of environmental conditions.

*Westcode Semiconductors, Chippenham, Wilts.*

903M



# MARKET

## LCD multimeters

Two low cost LCD multimeters have been added to the existing range of N.L.S. DMM's. The LM 300 has a 3 digit high contrast display powered by 3 AA size cells which can be either zinc-

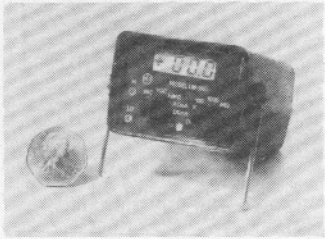

carbon or the optional nickel cadmium with an external mains adaptor. The 21 ranges cover AC and DC volts in 1-10-100-1 KV and AC DC current in 1-10-100-1000 mA ranges. Resistance is measured in 5 ranges from 1 Kohm to 10 Mohm. All ranges are fully protected and will withstand up to 1 Kv DC or AC peak on any voltage range. The LM 350 is similar to the LM 300 but with a 3½ digit scale and 100% coverage. Case size is only 1.9"x2.7"x4.0". Price £ 74.00 (+ V.A.T.) for the LM 300 and £ 87.00 (+ V.A.T.) for the LM 350.

*Lawtronics limited*  
139 High Street, Edenbridge,  
Kent TN8 5AX.

(833 M)

## Etch resist dry transfers

The Belgium company of Alfac

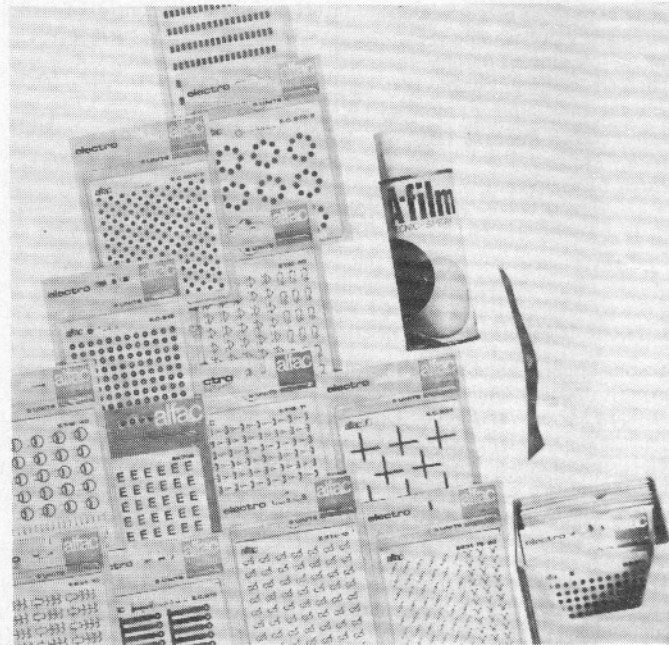

are now marketing in England a range of about 100 different electro Symbols which will enable amateurs and industrial users to make up P.C.B.'s much more quickly, easily and accurately. Alfac etch resist electro symbols can be transferred directly on to copper clad boards for making 'one-off' P.C.B.'s, or they can be used on drafting film to make electronic circuit diagrams. They are made in a range of component sizes, and they give exact and correct spacings for intergrated circuits and transistors. Alfac transfers need no special fixing, since the double action adhesive prevents the symbols moving when they are laid down. The quality of the special ink which is used by Alfac eliminates any cracking, and a very professional finish can be achieved. They are economical in price and are available in handy blister packs which are ideal for storage. Further details may be obtained from the Alfac sole agents in the U.K.

*Pelltech Ltd., Alfac Electro*  
Division, 6 Church Green  
Witney Nr. Oxford, England.

(839 M)

## VSWR bridge

This VSWR Bridge has been specifically designed for use with transmitters capable of producing

high power outputs. Unlike many of the other VSWR Bridges on the market, this particular piece of equipment will handle the high power without giving misleading results.

This so often occurs due to high sensitivity in order to read low power levels. When at high power levels the diodes which detect the sampled portion of R.F. energy become saturated and can no longer be relied upon to give a true reading.

With this problem in mind, the sensitivity of the instrument has been deliberately reduced.

The heart of the instrument is a double sided glass fibre printed circuit board with a printed stripline of a characteristic impedance of 50 ohms.

The forward and reflected power measurement is accomplished by means of a loosely coupled printed line with diodes at each end and a high quality carbon film "cermet" trimmer, to enable the instrument to be calibrated precisely, fixed at the centre point.

Connection to the 50 ohm stripline is by means of "N" type flange connectors with low inductance grounding of the body to the ground plane of the double sided printed circuit board.

The measurement of the voltage standing wave ratio is directly calibrated on a moving coil meter mounted on the front panel of the instrument, along with a sensitivity control to set full scale deflection on the forward range. A miniature rocker switch switches between the forward and reflected detectors.

### Specification:

Impedance	— 50 ohms
Sensitivity	— 5 Watts
	@ 432 MHZ
	10 Watts
	@ 144 MHZ
Input/Output	— 'N' type
Connectors	UG 58/U
Maximum	— 500 Watts
Power Levels	@ 432 MHZ
	1,000 Watts
	@ 144 MHZ

*Polar Electronic*  
Developments Ltd.,  
Domville Road,  
Liverpool L13 4AT England.

(831 M)

## Hi-power VHF V-FETs

A new range of vertical-geometry V-channel field-effect transistors,

available in the UK from Walmore Semiconductors, can handle continuous-wave output powers of up to 100 W at frequencies of 175 MHz. The devices, manufactured by Communications Transistor Corporation, draw negligible d.c. input gate current, making biasing and modulation much simpler, and are much more rugged than comparable bipolar devices.

The new range of V-FET products, intended for r.f. amplifier applications, includes

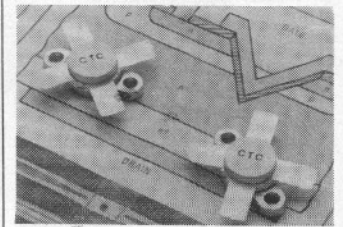

three devices — the BF25-35, BF50-35 and BF100-35 — designed to handle 25, 50 and 100 W of continuous-wave power, respectively. All the transistors are characterised for operation at either 80 or 175 MHz.

The ease of biasing and modulation, plus the ruggedness of the devices, are important features of the V-FET devices. The problems of thermal runaway or breakdown, sometimes encountered with bipolar transistors do not occur, and hence the devices are more tolerant of load mismatch.

The third-order distortion of the V-FET devices is similar to that of bipolar products, while the square-law-type characteristics of the V-FET technology gives a higher-order distortion figure 5 -10 dB lower than that for comparable bipolar devices.

Noise performance is also improved because the V-FET is a majority-carrier device.

The vertical V-channel structure allows a very narrow diffusion to take place, which leads to a good frequency response.

Interconnection of a large vertical area of tightly defined gates also allows the higher power levels to be achieved.

Maximum gain of the V-FET rf power transistors is 10 dB at 175 MHz. Breakdown voltage from source to drain is more than 65 V, and the source-to-gate breakdown voltage is more than 25 V. Typical 'on' resistance is less than 1 Ω measured at a 10 A drain current for the 100 W transistor.

*Walmore Semiconductors,*  
11-15, Betterton Street,  
Drury Lane, London,  
WC2H 9BS England.

(836 M)

# MARKET

## Smaller capacitor

A new range of aluminium electrolytic capacitors available from Gould Electronic Components Division is available in cylindrical aluminium cases with axial wires for easy mounting. Designated Secorel 85, the new capacitors range in size from 6.5 mm diameter and 15 mm long up to 25 mm diameter and are designed to fill an important need for high-performance capacitors in smaller size ranges. The Secorel 85 Series is a professional-grade range using a similar standard of construction and the same advanced electrolyte as the established Gould Prosec and Indel ranges. Eight sizes are available, with capacitance values ranging from 1  $\mu\text{F}$  to 22 000  $\mu\text{F}$  and voltages from 6.3 V to 350 V d.c.

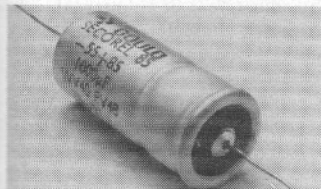

Allied ranges with very low equivalent series resistance, designed for use at the high frequencies encountered in switch-mode power supplies, are the Secorel 032 and FRS Series. The 032 range is available with working voltages from 6.3 V to 100 V d.c. and capacitances from 6.8  $\mu\text{F}$  to 1000  $\mu\text{F}$ , and offers the same capacitance/voltage per can size as the Secorel 85. The FRS range provides even lower equivalent series resistance, but at some sacrifice of capacitance/voltage per volume.

Operating temperature range of Gould Secorel capacitors is  $-55^{\circ}\text{C}$  to  $+85^{\circ}\text{C}$ , capacitance tolerance is  $-10\%$ ,  $+50\%$ , and shelf life is 3 years. Because of their low leakage current and good stability, Gould Secorel capacitors can be used in time-constant, timing, differentiation and integration circuits in addition to the usual coupling, decoupling and smoothing applications.

Gould Electronic Components Division,  
Rhosymedre,  
Wrexham, Clwyd.

(914 M)

## Midiget power reed relay

Despite measuring only 25 mm long by 8 mm wide, the Erg PM 21

midiget reed relay can switch up to 20 W, both a.c. and d.c. Coil power required is only 70 mW. This 1 Form A (n.o.) s.p.s.t. component has a switching rate of 1000 Hz. Initial contact resistance is 50 m $\Omega$  max. and insulation resistance  $10^{12} \Omega$ . Off-the-shelf 10 W versions of the Erg PM 21 reed relay have contacts rated at 200 V 0.5 A (1A carry), with initial contact resistance of 200 m $\Omega$  and insulation resistance  $10^8 \Omega$ .

Insulation resistance between reed and coil (for both versions of the PM 21) is  $10^{10} \Omega$  min. at 500 V d.c. min., while dielectric strength between reed and coil is 500 V r.m.s. min. The relays are completely encapsulated with leadout pins set on a standard 0.1in. pitch for p.c.b. mounting. All relays incorporate internal magnetic screens. These minimise interaction from adjacent relays to only 10% of the "just operate" voltage when a relay is mounted between two similar relays with 0.1in. spacing. Weight of the

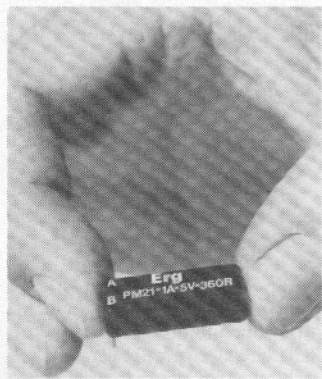

PM 21 is just 3 gm. It is available in coil voltages of 5, 12 and 24 V and the relays will work satisfactorily with a  $\pm 10\%$  voltage variation. Vacuum-encapsulation in epoxy resin with glassloaded shells and headers gives reliable protection even in unfavourable environments. The PM 21 relays are designed to conform to the requirements of draft BS 9512. Special versions of the PM 21 are available to order. Price of the relay is around £1 dependent upon quantity.

Erg Industrial Corporation Limited,  
Luton Road, Dunstable,  
Bedfordshire LU5 4LJ.

(922 M)

## Complementary transistors

Eight new PNP and NPN transistors with 80 V collector-

emitter voltages, 5 A continuous collector currents and operating frequencies to 70 MHz, provide high-performance in power amplifier and switching circuits. Developed by Solid State Devices, Inc., the 2N5002, 2N5005, 2N5151 and 2N5153 PNP transistors have 100 V collector-base voltages, 2 A continuous base currents and emitter-base voltages of 5.5 V. The 2N5003 and 2N5151 have static forward-current transfer ratios of

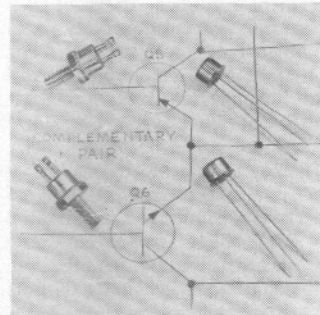

30 minimum to 90 maximum @ 5 V  $V_{CE}$  and 2.5 A  $I_C$ . The 2N5003 and 2N5153 have a transfer ratio of 70 minimum and 200 maximum with the same drive conditions. Typical turn-on time is 0.5  $\mu\text{sec}$  while turn-off time is 1.3  $\mu\text{sec}$ .

The NPN devices, 2N5002, 2N5004, 2N5152 and 2N5154, have similar electrical ratings permitting their use in complementary-pair circuits. For broad safe-operating areas, the devices have a 15 mJoule reverse-energy rating. The 2N5002 to 2N5005 devices, packaged in the TO-59 case, have a continuous dissipation of 50 W @  $50^{\circ}\text{C}$  case temperature. The 2N5151 to 2N5154 in TO39 packages are rated at 10 W @  $50^{\circ}\text{C}$  case temperature.

Solid State Devices, Inc.,  
14830 Valley View Avenue,  
La Mirada, California 90638 USA.

905 M

## Static inverter

A new static inverter from Bandenburg Ltd., the

Model 060-02, is specifically designed as a prime power source for the Hawker Siddeley HS748 aircraft, and is ideal for retrospective fitting in place of the conventional rotary inverter. The 060-02 meets BS 3G100 specifications on shock, vibration and humidity, and is supplied with a mounting tray designed to fit the HS748.

Because the 060-02 static inverter is a purely electronic device with no moving parts, it avoids the problems of wear and maintenance which traditionally occur with electromechanical inverters. The inverter provides a 3-phase output of 1500 VA total rating from a nominal 28 V d.c. supply; each output is rated at 500 VA at 115 V, 400 Hz and phase-shifted by  $120^{\circ}$ .

Output voltage and frequency are maintained constant over a wide range of input voltages, loads and environmental conditions, and the unit maintains a balanced output voltage even where there is a high degree of load imbalance. The 060-02 is of rugged design to ensure trouble-free operation under the conditions of shock and vibration normally encountered in civil aircraft, and cooling by natural convection.

The output voltage on each phase is maintained at  $115 \text{ V} \pm 1.5 \text{ V}$  r.m.s. over the normal input voltage range, and the output frequency is  $400 \text{ Hz} \pm 4 \text{ Hz}$  over the full operating temperature range of  $-35^{\circ}\text{C}$  to  $+55^{\circ}\text{C}$  at ground level, or  $-20^{\circ}\text{C}$  to  $+45^{\circ}\text{C}$  at altitudes of up to 15.2 km. The total harmonic content of the output does not exceed 5% with a 1500 W resistive load for normal input voltages.

Brandenburg Ltd. has approval from the Civil Aviation Authority under the Air Navigation Order for the supply of equipment used in civil aircraft.

Brandenburg Limited,  
High Voltage Division,  
939 London Road,  
Thornton Heath,  
Surrey, CR4 6JE.

(911 M)

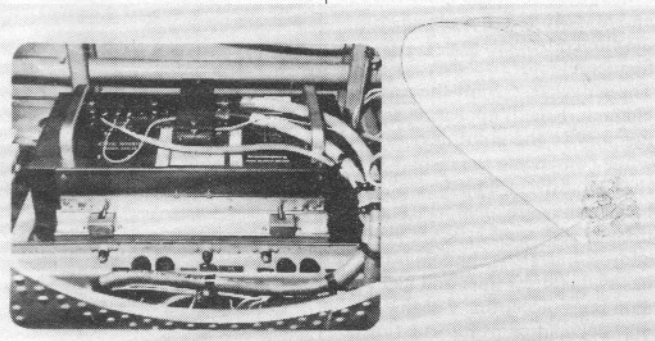



# MARKET

## Transparent epoxy elastomer

Eccogel 1265 is a two part epoxy resin which will cure at room temperature to a clear tough, but flexible solid. Eccogel 1265 bonds well to most substrates and is therefore useful as a flexible interface between dissimilar materials. Typical of this type of application is the bonding of safety screens to cathode ray tubes.

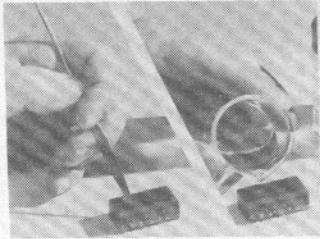

Cured Eccogel 1265 is sufficiently flexible that a 1/2" square, 12" long rod can be tied in a knot, and this allows the material to be used for the encapsulation of pressure sensitive devices, or delicate components such as fluorescent tubes.

When first mixed Eccogel 1265 has a very low viscosity and will readily impregnate components and will also produce bubble free castings. The cured material may be cut open and faulty components removed. Repair is effected by refilling the cavity with fresh material.

Eccogel 1265 also exhibits excellent vibration damping properties.

The photograph shows how a circuit module encapsulated with Eccogel 1265 is cut with a knife, repaired and resealed with Eccogel 1265.

*Emerson & Cuming (U.K.) Ltd, Colville Rd., Acton, London W3.*

904 M

## First schizophrenic CMOS IC

A unique pair of CMOS "Display Controller" IC's, the MM74C911 and MM74C912, have been developed by National Semiconductor.

These devices exhibit the unusual characteristic of appearing as memory to the input devices, while convincing the display that they are drivers. The device inputs believe they are memory. They may be addressed as RAM via address buffers — the MM74C911 has two address lines and eight data lines (accepting 7-segment plus decimal point information)

whilst the MM74C912 has three address lines and five data lines (accepting BCD plus decimal point information). The outputs, however, are convinced they are drivers — and to prove it they are multiplexed to drive 4-digit (MM74C911) or 6-digit (MM74C912) LED or gas discharge 7-segment displays. The segment outputs will drive up to 100 mA each. This is achieved using a buffered guard bank CMOS process in which the segment outputs make use of a parasitic NPN emitter follower bipolar transistor structure inherent in the CMOS process and an N-channel sink transistor. Digit outputs drive the digit transistors directly.

The key to these devices' split personality is their 'Central nervous system':

— MM74C912 accepts the BCD information into one of six 5-bit latches. The latch outputs are scanned by an internal oscillator, decoded to 7-segment format by a 16 x 7 Read Only Memory (ROM), and fed to NPN segment drivers. Segment outputs can be TRI-STATE — especially useful for display blanking in a standby power mode.

MM74C911 operates similarly, except that the 8-bit input data after latching is fed directly to the segment drivers, without further decoding. This device is capable of digit and segment expansion. For example, two 74C911's can be cascaded to drive a 16-segment alphanumeric display.

Chip size is 130 x 130 mil, and both devices come in 24 pin DIL packages.

Applications include micro-processor display buffers, clock systems, silent hospital paging systems, personalised message receivers and pin-ball machines.

*National Semiconductor Ltd., 301 Harpur Centre, Horne Lane, Bedford, MK40 1TR.*

(908 M)

## 1.7 dB noise at 4 GHz

A new packaged microwave GAAS FET with the lowest

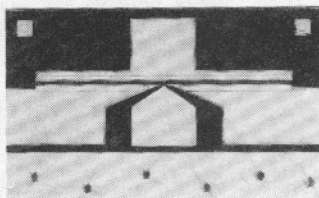

guaranteed noise figure at 4 GHz in the industry and superior gain characteristics has been introduced by Hewlett-Packard. The new HFET-1102 Low Noise Transistor has a guaranteed 1.7 dB maximum noise figure at 4 GHz and a useful range from 1 to 12 GHz. This low noise performance makes the HFET-1102 ideal for use in critical first stage microwave receiver/amplifier applications in land and satellite communications, radar, avionics and ECM.

In addition to its quiet performance, the HFET-1102 has a high minimum associated small signal gain of 11.0 dB at 4 GHz, which should minimize distortion even at the moderate power levels at which the device can be operated.

The new transistor is packaged in the hermetically sealed HPAC-100A for rugged, reliable performance in demanding applications.

Price of the HFET-1102 is £104.40 each for 1 to 9 units; £91.87 each for 10 to 24 units; and £83.52 each for 25 to 49 units. Delivery is from stock.

*Hewlett-Packard Limited, King Street Lane, Winnersh, Wokingham, Berkshire. RG11 5AR*

901 M

## Optical shaft encoder

A new medium-resolution optical shaft encoder specifically developed for the industrial and instrument markets, has been introduced by the Ferranti Industrial Components Group, Dalkeith. Known as the Ferranti Model 24 ST encoder, it has a stainless steel shaft carried on ballbearings and a stainless steel protective can. It is mechanically robust and well protected. In addition, a tough optical plastic disc is used in preference to glass, for increased resistance to shock. A powerful output drive stage gives a high degree of immunity to noise and a unique low-level operation LED circuit provides an extended life expectancy compared with conventional units.

The counting range extends between 200 and 635 lines per revolution. Dual outputs in quadrature and a once per revolution marker pulse, all at 5 volt logic levels, are offered as standard. Operation at up to 10,000 r.p.m. is specified for normal life application. The Ferranti Model 24 ST encoder is a

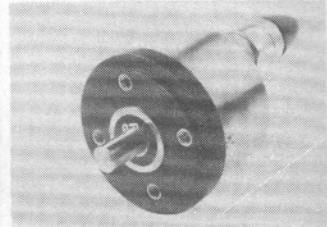

medium-resolution unit that provides all-round mechanical and electrical reliability.

*Industrial Products Department, Ferranti Limited, Thornybank Trading Estate, Dalkeith, Midlothian, EH22 2NG.*

(915 M)

## Alphanumeric printer

The Printina CSC is a 24-column alphanumeric printer. However, by adjustment of an internal trimmer, characters may be compressed until 32 columns be printed on a single line. The CSC accepts bit parallel character serial inputs coded according to 6 bits ASCII, or to 4 bits BCD if only numbers are used.

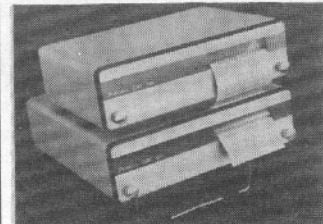

Fastest print rate is 1.2 lines/second at 5.2 power supply (the unit will operate from 5 V ± 5% or 6-8 V d.c.). Write time is approximately 400 ms. Life is estimated at 10<sup>6</sup> lines without service.

The printer uses standard rolls of metallised electro-sensitive paper. A roll 25 metres long allows 5,000 lines to be printed. Paper flow is downwards. The paper roll is stored internally and a new roll can be fitted easily in a matter of seconds.

One of the most rugged printers available, the CSC can withstand the most severe environmental conditions.

Price of the Printina CSC is only £195 (25+) and it is also available without case as a single p.c.b. printer for O.E.M. applications. Housed in a cabinet measuring 54 x 192 x 130 mm, the printer weighs only 1 kg.

*Seltek Instruments Limited, Hoddesdon Road, Stanstead Abbots, Herts SG12 8EJ.*

(910 M)

# MARKET

## Multi-purpose DIL package

The new Erg DILpack 14 is a low-profile multi-purpose DIL packaging component. Basically a precision-moulded 14-pin DIL skeleton package, it offers a choice of two tight-fit, snap-on covers giving a 5.7 mm or 8.9 mm height profile, and can house numerous components. Because of the close tolerance and tight fit of the covers, components may be encapsulated easily. The Erg DILpack plugs directly into any standard 0.1 in. hole spacing; either a DIL socket or directly onto a p.c.b. for flow soldering. The two rows of 7, linked terminals may be individually disconnected using only wire cutters, and can be linked and/or cross-linked with direct soldered connection wires. This feature allows the DILpack to be used for preparing programme addresses.

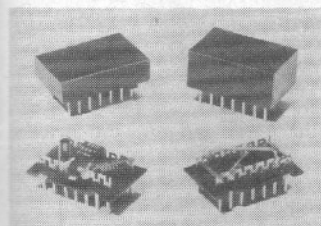

Hybrid circuits and/or passive networks may be built inside and fully protected from environmental hazards. Using ribbon or regular 14-way cable with an Erg DILpack at each end provides a simple and inexpensive means of reliable board-to-board coupling. Moulded in glass reinforced nylon, these packaging components can be used in the temperature range  $-55^{\circ}\text{C}$  to  $+100^{\circ}\text{C}$ . Both connections and pins are hard gold plated. Delivery is ex stock. Price 25p each (100 rate).

*Erg Industrial Corporation Limited,  
Luton Road,  
Dunstable, Beds LU5 4LJ.*

(916 M)

## Variable geometry power transformers

Parmeko Ltd have developed a range of toroidal power transformers based on a variable geometry concept. This allows variations in dimensions for transformers of a given rating to fit them within confined spaces and thereby overcome one of the major problems facing users of electronic circuits.

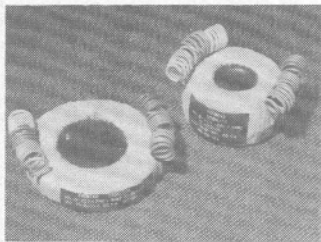

Recent developments in 'micromin' electronics now demand smaller inductive components for a given electrical rating. Designers faced with this 'quart into a pint pot' problem will be helped considerably by the introduction of the Parmeko 5500 series of toroidal power transformers.

Compared to conventional laminated transformers of a similar rating, transformers of toroidal construction typically save about 45% of the volume and can reduce the height even more significantly. The variable geometry concept takes these space savings a stage further. It allows the shape to be changed in three ways: by altering the ratio of height to diameter; by selecting a small core with the winding space fully utilised; or by using a larger core with only part of the winding space utilised.

The 5500 series covers a power range at 50 Hz of up to 1 KVA, and within the overall range there is a selection of standard toroidal power transformers to cover popular applications with shorter lead times.

*Parmeko Limited,  
Percy Road,  
Leicester LE2 8FT*

(924 M)

## S100 Universal Micro-processor/Microcomputer prototyping board

Following the increasing use of the S100 board size and bussing system in microcomputers (e.g. Attair 8800, IMSAI 8080) and microprocessor applications, Vero Electronics Limited announce the release of a universal S100 bus-compatible prototyping board. This board is designed for the manufacture or breadboarding of microprocessor,

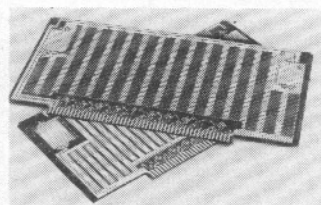

memory or interface assemblies, and will, without modification, mount directly into any equipment using the S100 bus system.

The layout of the Vero S100 prototyping board has been optimised for maximum flexibility in use and as a memory board will hold up to fifty-two 16-way DIP's (equivalent to 6K of memory) or in more general use, thirty-six 16-way plus eight 24-way plus two 40-way packages, making it ideal for microcomputer expansion and general digital and analogue circuits.

The board has an S100 edge connector configuration (i.e. 100 gold-plated contact fingers on 3,175 mm/0.125 inch pitch) and is fully pierced with 1,02 mm/0.040 inch diameter holes on a 2.54 mm/0.1 inch matrix. Provision is made for mounting up to four standard TO-220 plastic package regulators together with heatsinks for on board regulation, and the voltage plane is capable of being divided to provide up to four separate positive or negative supply rails. The component side of the board carries a ground plane which can be used for terminations or screening and the wiring side carries both voltage and ground planes, thus providing for up to five planes.

The board is intended primarily for interconnection by wire wrap methods, although connections can be made directly from wire wrap pins to the ground and voltage planes by use of the Vero 'Z' links. Alternatively the board can be used for soldered connections by using the Verowire pen which wraps a solder through insulated wire around the pins of solder spill DIP sockets.

A wide range of compatible standard accessories such as DIP sockets, pins, headers, ribbon cables etc., is available enabling the Vero S100 prototyping board to cope with virtually any micro-processor or microcomputer circuit requirement.

*Vero Electronics Limited,  
Industrial Estate, Chandler's Ford  
Eastleigh, Hampshire SO5 3ZR.*

(917 M)

## 3-Rail power supply

A three-rail Eurocard power supply announced by Lascar Electronics is claimed to be suitable for most circuits where digital and linear devices

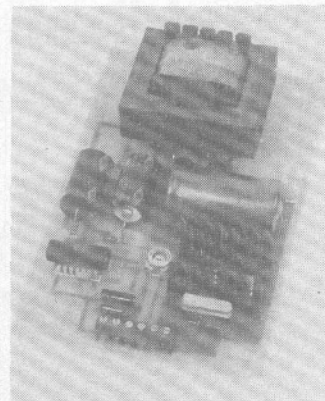

are mixed. They may also find application as micro-processor power supplies.

The supply features one output of 5 V 1000 mA, and dual tracking outputs adjustable between  $\pm 5$  V with a maximum of 100 mA per rail. The 5 V and twin-rail supplies are isolated from each other and feature short-circuit, over-temperature and fold-back over-current protection. Input voltages 220 V a.c. or 240 V a.c. The supply is fitted with terminal blocks on the input and outputs, and is assembled on a PCB measuring 160 x 100 mm, with a maximum height of 47 mm.

*Lascar Electronics Limited,  
P.O. Box 12, Module House,  
Billericay, Essex CM12 9QA.*

902 M

## Crystal Oscillators

Verospeed, the Vero Group's rapid despatch service, now have two DIP Packaged Crystal Oscillators included in their range of general electronic components.

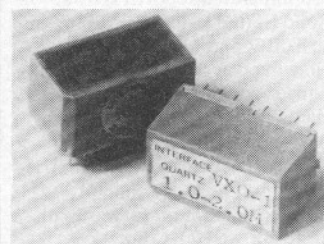

Both are TTL compatible. One has normal and complementary outputs at 1.0 and 2.0 MHz and the other has a single 10 MHz output. Priced at £ 9.36 and £ 11.96 respectively they are both becoming widely accepted in the electronics industry.

*Verospeed  
Barton Park Industrial Estate,  
Eastleigh, Hampshire, SO5 5RR  
England*

(855 M)



# MARKET

## Top access case

12 variations are currently available of a new version of the best selling 'D' Series instrument case from Vero Electronics Limited.

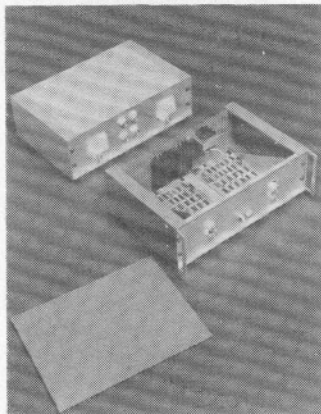

It features quick and easy access to the top of the case by removing 2 screws which release the top panel — ideal for microprocessor applications or chassis-mounted equipment, where immediate access is required.

Multiple front panel fixing, anti-slip feet and four optional colour finishes are further features of the range.

*Vero Electronics Limited,  
Industrial Estate, Chandler's Ford,  
Eastleigh, Hampshire, SO5 3ZR.*

(912 M)

## Miniature 6 A rectifiers

A new line of miniature 6 ampere ion-implanted rectifiers, from Solid State Devices, Inc., block up to 100 V and have a recovery time over two times faster than conventional devices. Designated the HSR-2-52 series, the devices have a typical reverse-recovery time of 15 nanoseconds with a maximum recovery time of 20 nsec. Maximum forward voltage drop, at 100°C junction temperature, is 825 millivolts; maximum reverse-leakage current is 20 microamperes.

By comparison, conventional high-speed rectifiers have a typical reverse-recovery time between 30 nsec and 50 nsec with forward drops of about 1 V. Typical reverse-leakage current is approximately the same as the HSR-2-52. Thought to be the smallest in their current and voltage range, the HSR-2-52 series devices measure only 0.15 inches high by

0.25 inches in diameter. The key to their high-power dissipation is packaging assembly. The die is eutectically bonded to a modified TO-18 transistor case which, along with one lead, serves as a high-current anode. The two other leads are ultrasonically bonded to the cathode with dual 10 mil wire.

Manufactured using SSDI's patented EPION<sup>®</sup> ion-implanted process, the devices are radiation hardened. This occurs because their low carrier lifetime permits operation at higher switching frequencies with lower forward-voltage drops. In addition, the small (70 mil square) device geometrically contributes to radiation tolerance. There are seven devices in the HSR-2-52 series with maximum peak-repetitive reverse voltages from 20 V to 100 V; maximum root-mean-square voltages are 15 V to 70 V. For all devices, average one-half wave rectified current is 6 A, with nonrepetitive surges to 125 A. Operating temperature range is -55°C to +175°C.



*Solid State Devices, Inc.,  
14830 Valley View Avenue,  
La Mirada, CA 90638 USA.*

(906 M)

## A match for any switch!

A 'rogue' matchstick lines up with a collection of tiny reed switches

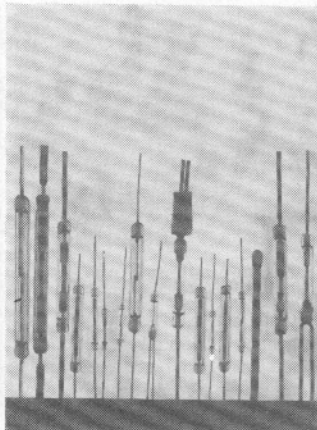

— ranging from 0.47 in. to 2.070 inches in length (11.6 mm-52.5 mm) — that can perform over one hundred electronic operations per second.

Made by a leading British company, the reed switch is a glass-encapsulated device in which the moving parts are cantilevered blades known as 'reeds'. These reeds are made of ferromagnetic material and are arranged so that their ends overlap, normally with a small air gap between them. The switch is operated by supplying an external magnetic field, which causes the blades to be attracted together to make contact. The simplicity of operation and the sealed environment in which they work gives the switches a long life — up to 100 million operations — and a very high degree of reliability.

Reed switches are initially found in areas where high speed and miniaturisation are significant factors. Telecommunications and data processing are two examples. They can also be found in power system controls, office machinery, anti-theft devices and vending and amusement machines.

*Astralux Dynamics Ltd.,  
Brightlingsea, Colchester, Essex,  
CO7 0SW, England.*

(907 M)

## Neat cases

A case for micro-processors, data terminals, calculators, etc. has been produced in four sizes by

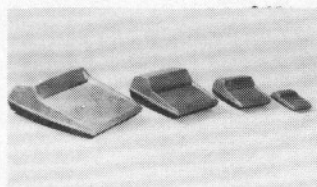

West Hyde. This range of four cases has been designed by R. Fran Sutton, M.S.I.A., N.R.D. The features include the correct angle of the keyboard and data display, the space to take Eurocards or double Eurocards, power supplies, etc., the connections to remain hidden; and a second steeper slope for displays or meters.

Produced in leather-grain black and tan or all leather-grain shiny black A.B.S., the cases are ex-stock and the prices include feet.

Prices from £ 3.90 for one off for the smallest size, with big quantity discounts.

*West Hyde Developments Ltd.,  
Unit 9, Park St. Ind. Est.,  
Aylesbury, Bucks. HP20 1ET.*

(928 M)

## Largest UK printed circuit board

Close co-operation between Stone Platt Crawley, and Circaprint Ltd., has resulted in a much faster and more efficient assembly operation of their Motorway Signalling Units manufactured at Crawley. The printed circuit board measures 22" x 26" and has 5,200 drilled holes, it carries 520 diodes, 137 lamp holders, and there are 1,600 soldered joints made in one flow solder pass.

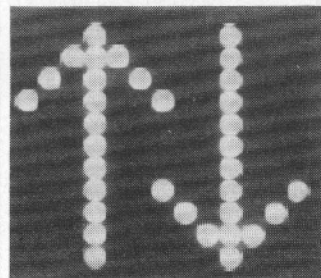

The printed circuit board is made exactly to a high specification, however, owing to its large size a special jig has been developed by Stone Platt, to ensure perfect flatness when it passes over the solder wave, resulting in less than a half per cent of dry joints. Circaprint supply conventional and Plated Through Hole printed circuit boards to numerous leading British Companies for application ranging from Brain Scanners to Automatic Telephone Exchanges.

*Circaprint Ltd.,  
Foster Street,  
Maidstone,  
Kent.*

(920 M)

# From Science of Cambridge: the new MK 14. Simplest, most advanced, most flexible microcomputer - in kit form.

**only  
£39.95  
(+ 8% VAT)**

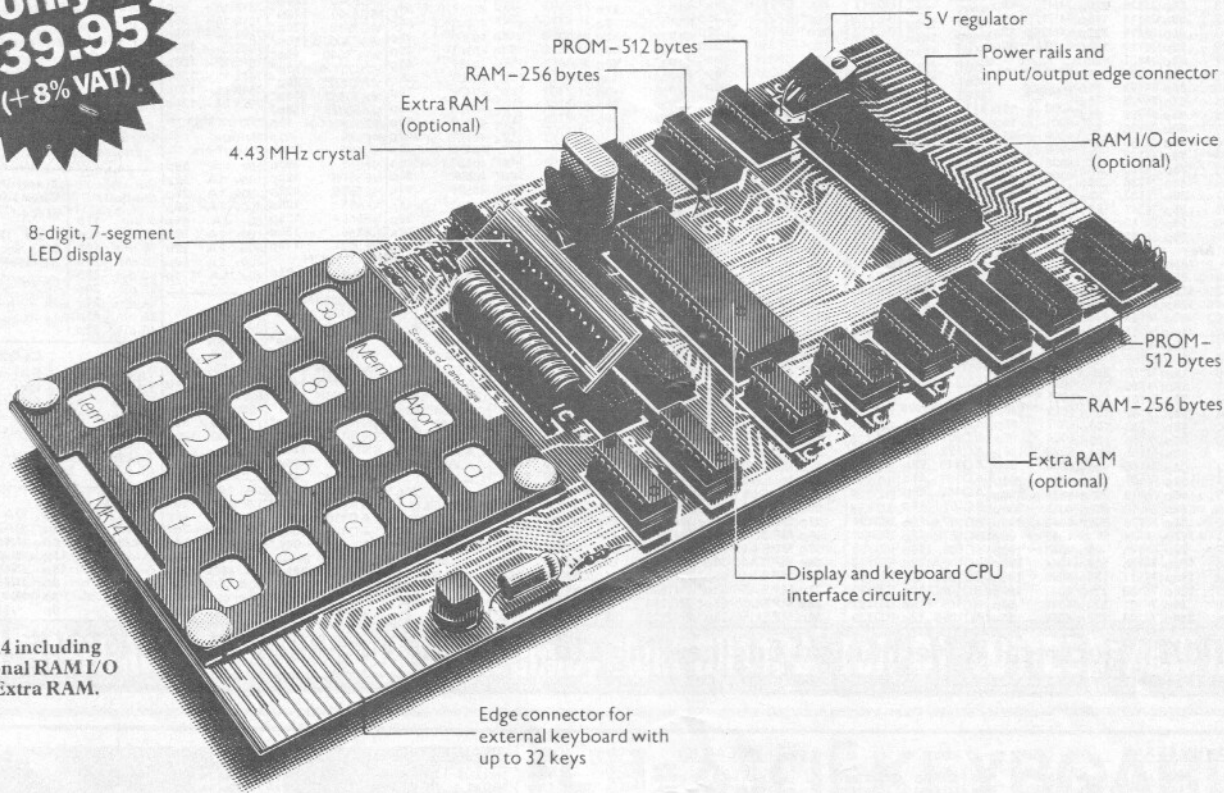

**MK 14 including optional RAM I/O and Extra RAM.**

The MK 14 is a complete microcomputer with a keyboard, a display, 8 x 512-byte pre-programmed PROMs, and a 256-byte RAM programmable through the keyboard.

As such the MK 14 can handle dozens of user-written programs through the hexadecimal keyboard.

Yet in kit form, the MK 14 costs only £39.95 (+£3.20 VAT, and p&p).

**More memory - and peripherals!**

Optional extras include:

1. Extra RAM - 256 bytes.
2. 16-line RAM I/O device (allowed for on the PCB) giving further 128 bytes of RAM.
3. Low-cost cassette interface module - which means you can use ordinary tape cassettes/recorder for storage of data and programs.
4. Revised monitor, to get the most from the cassette interface module. It consists of 2 replacement PROMs, pre-programmed with sub-routines for the interface, offset calculations and single step, and single-operation data entry.
5. PROM programmer and blank PROMs to set up your own pre-programmed dedicated applications.

All are available now to owners of MK 14.

**A valuable tool - and a training aid**

As a computer, it handles operations of all types - from complex games to digital alarm clock functioning, from basic maths to a pulse delay chain. Programs are in the Manual, together with instructions for creating your own genuinely valuable programs. And, of course, it's a superb education and training aid - providing an ideal introduction to computer technology.

**SPECIFICATIONS**

- Hexadecimal keyboard ● 8-digit, 7-segment LED display ● 8 x 512 PROM, containing monitor program and interface instructions ● 256 bytes of RAM ● 4 MHz crystal ● 5 V regulator ● Single 8 V power supply ● Space available for extra 256-byte RAM and 16 port I/O ● Edge connector access to all data lines and I/O ports

**Free Manual**

Every MK 14 kit includes a Manual which deals with procedures from soldering techniques to interfacing with complex external equipment. It includes 20 sample programs including math routines (square root, etc), digital alarm clock, single-step, music box, mastermind and moon landing games, self-replication, general purpose sequencing, etc.

**Designed for fast, easy assembly**

The MK 14 can be assembled by anyone with a fine-tip soldering iron and a few hours' spare time, using the illustrated step-by-step instructions provided.

**How to get your MK 14**

Getting your MK 14 kit is easy. Just fill in the coupon below, and post it to us today, with a cheque or PO made payable to Science of Cambridge. And, of course, it comes to you with a comprehensive guarantee. If for any reason, you're not completely satisfied with your MK 14, return it to us within 14 days for a full cash refund.

**Science of Cambridge Ltd,  
6 Kings Parade, Cambridge, Cambs., CB2 1SN.  
Telephone: Cambridge (0223) 311488**

**To: Science of Cambridge Ltd, 6 Kings Parade, Cambridge, Cambs., CB2 1SN.**  
Please send me the following, plus details of other peripherals:

MK 14 Standard Microcomputer Kit @ £43.55 (inc 40p p&p.)  
 Extra RAM @ £3.88 (inc p&p.)  
 RAM I/O device @ £8.42 (inc p&p.)

I enclose cheque/money order/PO for £ \_\_\_\_\_ (indicate total amount.)

Name \_\_\_\_\_  
 Address (please print) \_\_\_\_\_  
 \_\_\_\_\_  
 \_\_\_\_\_  
 \_\_\_\_\_

Allow 21 days for delivery.

# Science of Cambridge



# Now, from the breadboard specialists— even better boards!

Since the appearance of the first breadboards back in the '40's, we've really been going places. (The U.K., for one.) So we now have an exceptional range of prototyping products which are outstanding in their simplicity, versatility and reliability. Just see. (And for prices and specs., eyes left!)

**1**

### Experimenter Series.

Low-cost, interlocking, solderless breadboard — the world's first for 0.3 in. and 0.6 in. pitch DIPs.

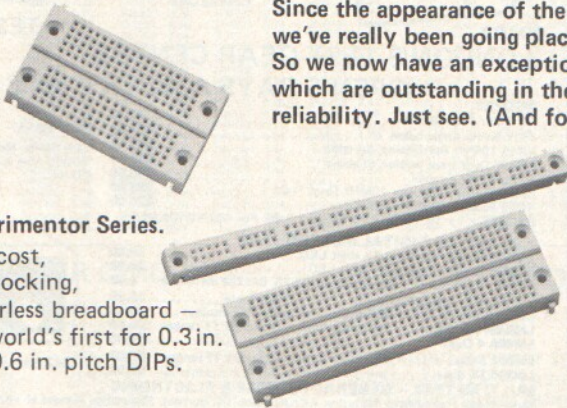

**2**

### Quick Test Series.

Low-cost, snap-locking solderless circuit boards for fast design with discrete components.

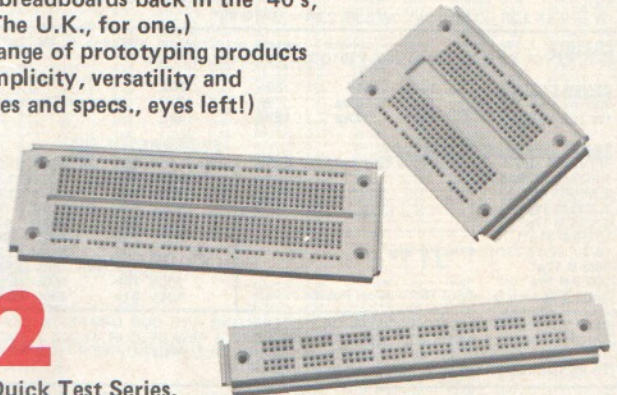

**3**

### The ProtoBoard Series.

Solderless breadboards with built-in 10% regulated 5Vd.c. 1A power supply; 2,250 solderless tie points; and capacity for DIPs of 14 to 40 pins.



Take a look at our low, low prices and quality specs., and get aboard! (Or if its data you're after, pick up the phone or drop us a line.)

For the best, from the specialists in breadboards.

**4**

### Design Mate Test Instruments.

DM-1 power supply, 5V to 15Vd.c. at 600mA; DM-2 function generator for sine, square and triangle wave generation; DM-3 R/C bridge giving 10 ohm to 10 megohm, 10pF to 1.0µf; DM-4 pulse generator with 0.5 Hz to 5MHz frequency and 100ns to 1 sec pulse widths.



### IC Test Clips.

Ultra-low cost IC clips in 14, 16, 24 and 40 pin versions.

And, much more too: logic monitors, probes, frequency counters and test equipment to ensure the best, fastest results from your design.



Continental Specialties Corporation (U.K.) Ltd., Unit 1, Shire Hill Industrial Estate, Dept. 2H Saffron Walden, Essex. CB11 3AQ Telephone (0799) 21682 Telex 817477 Reg. in London: 1303780. VAT No: 224 8074 71. \*Trade Mark applied for © CSC (UK) Ltd. 1977 Dealer enquiries welcome.

Please supply \_\_\_\_\_

\_\_\_\_\_ Price \_\_\_\_\_ Total \_\_\_\_\_

Name \_\_\_\_\_ Address \_\_\_\_\_

\_\_\_\_\_ My cheque/postal order No \_\_\_\_\_ for £ \_\_\_\_\_ is enclosed

My Access/American Express/Barclaycard no. is \_\_\_\_\_ All I want is data, please.

**We're on Stand B1 at the Breadboard exhibition.**



7400	14p	74109	50p
7401	14p	74118	90p
7402	14p	74120	90p
7403	14p	74121	25p
7404	14p	74122	40p
7405	14p	74123	60p
7406	40p	74125	50p
7407	40p	74126	50p
7408	20p	74128	75p
7409	20p	74130	130p
7410	20p	74131	100p
7411	20p	74132	65p
7412	20p	74134	65p
7413	30p	74136	80p
7414	60p	74137	100p
7416	30p	74138	125p
7417	30p	74141	60p
7420	15p	74142	270p
7421	30p	74144	270p
7422	20p	74145	75p
7423	25p	74147	230p
7425	25p	74148	160p
7426	25p	74150	120p
7427	25p	74151	65p
7428	40p	74153	65p
7430	15p	74154	120p
7432	25p	74155	70p
7433	25p	74156	70p
7434	25p	74157	70p
7438	25p	74160	90p
7440	15p	74161	90p
7441	65p	74162	90p
7442	65p	74163	90p
7443	110p	74164	125p
7444	110p	74165	125p
7445	80p	74166	325p
7446	85p	74170	200p
7447	75p	74173	150p
7448	70p	74174	100p
7450	15p	74175	100p
7451	15p	74176	100p
7453	15p	74177	100p
7454	15p	74178	140p
7460	15p	74179	140p
7470	30p	74180	200p
7472	30p	74181	200p
7473	30p	74182	75p
7474	30p	74184	150p
7475	30p	74185	150p
7476	30p	74186	350p
7480	45p	74189	350p
7481	95p	74190	140p
7482	80p	74191	140p
7483	85p	74192	120p
7484	90p	74193	120p
7485	100p	74194	100p
7486	30p	74195	75p
7489	35p	74196	100p
7490	35p	74197	100p
7491	75p	74198	160p
7492	45p	74199	185p
7493	40p	74200	150p
7494	80p	74201	150p
7495	60p	74202	25p
7496	70p	74212	100p
7497	250p		
74100	95p	7805	140p
74104	40p	7812	140p
74105	80p	7815	140p
74107	30p	7818	140p
74108	125p	7824	150p
74166	125p		

LINEAR			
AV3 8500	450p	SL9178	650p
AV3 8710	890p	SN7603N	180p
AV3 8760	890p	SN7603ND	180p
CA3060	225p	SN7603N	180p
CA3065	200p	SN7603ND	180p
CA3084	250p	SN76227N	160p
CA3085	85p	SN76227N	160p
CA3086	60p	SN76227N	160p
CA3088	190p	SN76660N	75p
CA3089	210p	TAA300	100p
CA3090 AQ	40p	TAA350	190p
CA3130	100p	TAA550	50p
CA3140	100p	TAA570	220p
CA3123E	200p	TAA661B	140p
LM211H	250p	TAA700	390p
LM300 T05	170p	TAA790	350p
LM301 AN	35p	TAD100	160p
LM304	250p	TBA1205	130p
LM307N	65p	TAD110	130p
LM308 T05	130p	TBA1205	90p
LM308 DIL	130p	TAA2800	200p
LM309K	100p	TBA5200	250p
LM310 T05	150p	TBA5300	215p
LM311 T05	260p	TBA540	230p
LM317K	325p	TBA540	250p
LM324	150p	TBA5500	250p
LM348N	200p	TBA560C	335p
LM380N	110p	TBA6A1A12	70p
LM392N	135p	TBA700	200p
LM391	180p	TBA7200	250p
LM555	28p	TBA7500	225p
LM709C	50p	TBA800	110p
LM710 T05	60p	TBA810	110p
LM710 DIL	65p	TBA820	100p
LM723 T05	75p	TBA9200	300p
LM723 DIL	180p	TBA2706	135p
LM741	25p	TCA2700	250p
LM748	45p	TCA2705	250p
LM1303N	155p	TCA760	350p
LM1458	100p	TDA2020	325p
LM3900	90p	XR320	250p
LM3900N	90p	XR2706	675p
MC1310P	185p	XR2207	450p
MC1312P	190p	XR2208	650p
MC1314P	190p	XR2216	850p
MC1315P	230p	XR2567	250p
ML747CP	75p	Y4136	250p
MM5314	430p	Y4202	150p
MM5316	550p	Y4212	150p
NE529K	150p	Y4739	150p
NE555	28p	ZN414	120p
NE556	100p		

POTENTIOMETERS			
220C/16	35p	4700/63	120p
2200/40	80p	4700/70	135p
2200/63	80p	10000/10	100p
2200/100	150p	10000/25	150p
3300/30	90p	15000/15	150p
3300/63	90p	15000/25	200p
4700/25	65p		

ENQUIRES FOR ANY OTHER TYPES

ELEC CAPACITORS			
0.47 25	7p	47 10	8p
1 16	7p	47 16	8p
1 25	7p	47 25	8p
1 50	7p	47 35	8p
2 25	7p	47 50	8p
2 25	7p	100 10	8p
3 3 25	7p	100 16	8p
4 7 10	7p	100 25	8p
4 7 16	7p	100 30	8p
4 7 25	7p	100 50	8p
4 7 50	7p	100 63	8p
6 8 25	7p	220 25	14p
10 10	7p	220 50	22p
10 16	7p	330 25	15p
10 25	7p	330 35	15p
10 50	7p	330 50	20p
22 10	7p	470 25	19p
22 16	7p	470 35	20p
22 25	7p	470 50	24p
22 35	7p	1000 16	27p
22 50	8p	1000 25	30p
33 6 3	7p	1000 35	35p
33 16	8p	1000 40	40p
33 25	8p	1000 63	50p
33 40	8p	1200 63	60p
33 50	8p	2200 10	30p

POLY CAPS			
1000 PF	5p	0.1 uF	6p
2200	5p	0.22 uF	7p
3300	5p	0.33 uF	9p
4700	5p	0.47 uF	12p
6800	5p	1.0 uF	20p
0.01 uF	5p	2.2 uF	25p
0.022 uF	5p	4.7 uF	35p
0.033 uF	5p	6.8 uF	40p
0.047 uF	5p		

TANT. BEADS			
0.1/35V	14p	3.3/16V	14p
0.15/35V	14p	4.7/16V	14p
0.22/35V	14p	4.7/25V	14p
0.33/35V	14p	4.7/35V	14p
0.47/10V	14p	6.8/6V3	14p
0.47/35V	14p	6.8/35V	14p
0.68/35V	14p	1.0/35V	14p
1.00/10V	14p	22/15V	21p
1.00/35V	14p	33/16V	25p
1.5/35V	14p	47/3V	20p
2.2/25V	14p	47/16V	25p
2.2/35V	14p	100/3V	25p

LATE EXTRAS			
400uF	400v	80p	
95H90		90p	
LF356		P.O.A.	
LF357		P.O.A.	
TDA1008		P.O.A.	
TDA1034		P.O.A.	

### TTL OFFERS

7410	10 for	1.50p
7412	10 for	1.50p
7420	10 for	1.00p
7430	10 for	1.00p
7432	10 for	2.00p
7442	10 for	3.00p
7474	10 for	2.00p
7476	10 for	2.50p
7483	10 for	7.00p
7493	10 for	2.50p
7496	10 for	4.50p
74107	10 for	2.00p
74121	10 for	2.50p
74153	10 for	4.00p
74161	10 for	8.00p

### CMOS

4000	14p	4043	250p
4001	14p	4045	150p
4002	14p	4047	100p
4006	90p	4048	55p
4007	16p	4049	40p
4009	55p	4050	40p
4011	14p	4054	120p
4012	14p	4055	140p
4013	55p	4056	135p
4015	90p	4060	120p
4016	40p	4066	55p
4017	90p	4069	20p
4018	90p	4070	25p
4020	100p	4071	16p
4022	90p	4072	16p
4023	16p	4077	35p
4024	65p	4081	16p
4025	16p	4082	16p
4026	160p	4510	120p
4027	55p	4518	130p
4028	90p	4520	130p
4029	110p	4528	100p
4032	90p		
4035	120p		

MURATA ULTRASONIC TRANSDUCER MA40LIR/S £2.50 Each £4.00 Pair

### SPECIAL OFFER

2000uF 35V 40p 100 for £30.00

### TRANSISTORS

AA113	10p	BC177	12p	BDX32	200p	BY127	15p
AA217	30p	BC177	15p	BDX42	50p	BY164	50p
AC121	20p	BC178	15p	BDY10	100p	BY133	25p
AC126	20p	BC182	10p	BF 115	20p	BY164	50p
AC127	20p	BC187L	12p	BF 120	50p	BYX94	8p
AC127 01	25p	BC183	10p	BF 121	45p	C1120	30p
AC128	20p	BC183L	12p	BF 123	45p	C1164	20p
AC151	25p	BC184	10p	BF 125	45p	E100	42p
AC153	30p	BC184L	12p	BF 127	50p	E201	50p
AC153K	40p	BC186	12p	BF 184	20p	GF 137	45p
AC184	20p	BC205	12p	BF 154	18p	E300	47p
AC187	20p	BC205	12p	BF 160	18p	E310	60p
AC188	20p	BC207	12p	BF 161	18p	E420	180p
AC189	35p	BC212	11p	BF 173	20p	E420	125p
AC191	35p	BC212L	12p	BF 178	25p	MJE340	45p
AC192	35p	BC213	12p	BF 179	25p	MPSA05	30p
AC193	35p	BC213L	15p	BF 180	30p	MPSA06	32p
AC194	50p	BC214	15p	BF 181	30p	MPSA56	32p
AC195	50p	BC214L	18p	BF 182	30p	PTP29	47p
AC196	50p	BC217	10p	BF 183	25p	PTP29C	49p
AD130	150p	BC268	16p	BF 184	20p	PTP30	75p
AD143	150p	BC268	16p	BF 186	25p	PTP30	55p
AD149	80p	BC294	30p	BF 194	10p	PTP30A	58p
AD161	40p	BC300	25p	BF 195	10p	PTP30B	65p
AD162	40p	BC301	25p	BF 196	10p	PTP30C	80p
AD161 7MP	90p	BC303	30p	BF 197	10p	PTP30D	85p
AF 114	25p	BC303	30p	BF 198	25p	PTP31A	55p
AF 115	25p	BC308	15p	BF 199	25p	PTP31B	60p
AF 116	25p	BC317	12p	BF 200	30p	PTP31C	75p
AF 117	25p	BC318	12p	BF 224	20p	PTP32	60p
AF 118	80p	BC323	30p	BF 225	20p	PTP33	115p
AF 178	95p	BC328	18p	BF 241	16p	PTP35	225p
AF 139	35p	BC337	14p	BF 244	35p	PTP35C	25p
AF 239	45p	BC338	18p	BF 255	25p	PTP41	