

EE

January 1978

ELEKTOR

up-to-date electronics for lab and leisure

Summa King

U.K. 50 p.
U.S.A./CAN. \$ 1.50

equaliser
uaa 180 ppm
function generator
noise generator

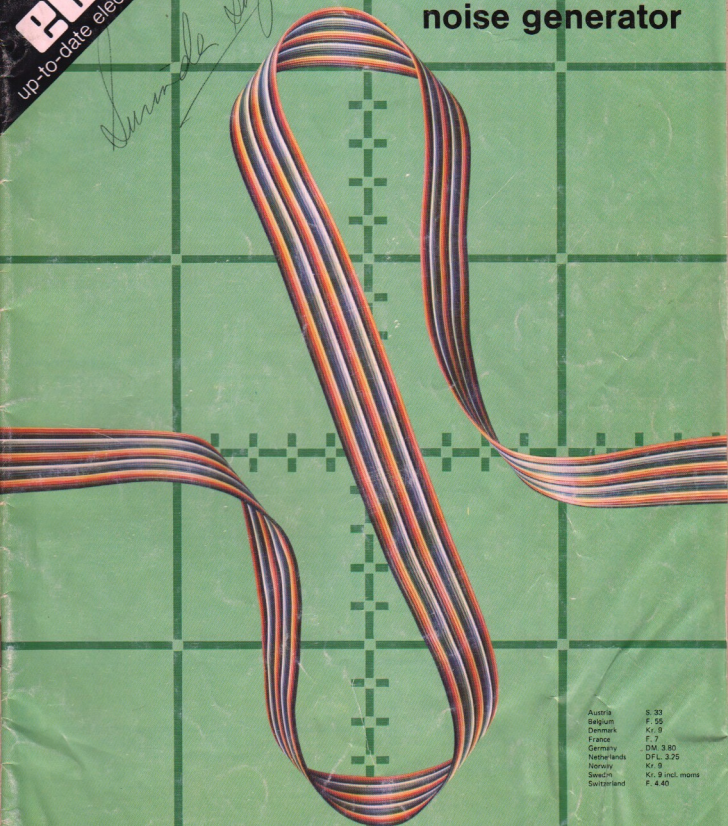

Austria S. 33
Belgium F. 55
Denmark Kr. 9
France F. 7
Germany DM. 3.80
Netherlands DFL. 3.25
Norway Kr. 9
Sweden Kr. 9 incl. moms
Switzerland F. 4.40

elektor 33

Volume 4

Number 1

Editor : W. van der Horst
 Deputy editor : P. Holmes
 Technical editors : J. Barendrecht
 G.H.K. Dam
 E. Krempelsauer
 G.H. Nachbar
 A. Nachtmann
 K.S.M. Walraven
 Subscriptions : Mrs. A. van Meyel

International head offices: Elektuur B.V.
 P.O. Box 75
 Beek (L), Netherlands
 Telex: 56617 Elekt NL

U.K. editorial offices, administration and advertising:
 Elektor Publishers Ltd., Elektor House,
 10 Longport Street, Canterbury CT1 1PE, Kent, U.K.
 Tel.: Canterbury (0227)-54430. Telex: 965504.
 Please make all cheques payable to Elektor Publishers Ltd.
 at the above address.

Bank: 1. Midland Bank Ltd., Canterbury, A/C no. 11014587
 Sorting code 40-16-11, Giro no. 3154254.
 2. U.S.A. only: Bank of America, c/o World Way
 Postal Center, P.O. Box 80689, Los Angeles,
 Cal. 90080, A/C no. 12350-04207.

Assistant Manager and Advertising : R.G. Knapp
 Editorial : T. Emmens

ELEKTOR IS PUBLISHED MONTHLY on the third Friday of each month.

1. U.K. and all countries except the U.S.A. and Canada:

Cover price £ 0.50.
 Number 39/40 (July/August), is a double issue,
 'Summer Circuits', price £ 1.—.
 Single copies (incl. back issues) are available by post from our
 Canterbury office, at £ 0.60 (surface mail) or £ 0.95 (air mail).
 Subscriptions for 1978, January to December incl.,
 £ 6.75 (surface mail) or £ 12.00 (air mail).

2. For the U.S.A. and Canada:

Cover price \$ 1.50.
 Number 39/40 (July/August), is a double issue,
 'Summer Circuits', price \$ 3.—.
 Single copies (incl. back issues) \$ 1.50 (surface mail) or
 \$ 2.25 (air mail).
 Subscriptions for 1978, January to December incl.,
 \$ 18.— (surface mail) or \$ 27.— (air mail).

All prices include post & packing.

CHANGE OF ADDRESS. Please allow at least six weeks for change of address. Include your old address, enclosing, if possible, an address label from a recent issue.

LETTERS SHOULD BE ADDRESSED TO the department concerned:
 TQ = Technical Queries; ADV = Advertisements; SUB = Subscriptions;
 ADM = Administration; ED = Editorial (articles submitted for
 publication etc.); EPS = Elektor printed circuit board service.

For technical queries, please enclose a stamped, addressed envelope or a self-addressed envelope plus an IRC.

THE CIRCUITS PUBLISHED ARE FOR domestic use only. The submission of designs or articles to Elektor implies permission to the publishers to alter and translate the text and design, and to use the contents in other Elektor publications and activities. The publishers cannot guarantee to return any material submitted to them. All drawings, photographs, printed circuit boards and articles published in Elektor are copyright and may not be reproduced or imitated in whole or part without prior written permission of the publishers.

PATENT PROTECTION MAY EXIST in respect of circuits, devices, components etc. described in this magazine.
 The publishers do not accept responsibility for failing to identify such patent or other protection.

National ADVERTISING RATES for the English-language edition of Elektor and/or international advertising rates for advertising at the same time in the English, Dutch and German issues are available on request.

DISTRIBUTION in U.K.: Spotlight Magazine Distributors Ltd.,
 Spotlight House 1, Bentwell Road, Holloway, London N7 7AX.

DISTRIBUTION in CANADA: Gordon and Gotch (Can.) Ltd.,
 55 York Street, Toronto, Ontario, M5J 1S4.

Copyright © 1978 Elektor publishers Ltd — Canterbury.

Printed in the Netherlands.

decoder

What is a TUN?
 What is 10 n?
 What is the EPS service?
 What is the TQ service?
 What is a missing link?

Semiconductor types

Very often, a large number of equivalent semiconductors exist with different type numbers. For this reason, 'abbreviated' type numbers are used in Elektor wherever possible:

- '741' stand for μ A741, LM741, MC641, MIC741, RM741, SN72741, etc.
- 'TUP' or 'TUN' (Transistor, Universal, PNP or NPN respectively) stand for any low frequency silicon transistor that meets the following specifications:

UCEO, max	20V
IC, max	100 mA
hfe, min	100
Ptot, max	100 mW
fT, min	100 MHz

Some 'TUN's are: BC107, BC108 and BC109 families; 2N3856A, 2N3859, 2N3860, 2N3904, 2N3947, 2N4124. Some 'TUP's are: BC177 and BC178 families; BC179 family with the possible exception of BC159 and BC179; 2N2412, 2N3251, 2N3906, 2N4126, 2N4291.

- 'DUS' or 'DUG' (Diode Universal, Silicon or Germanium respectively) stands for any diode that meets the following specifications:

	DUS	DUG
UR, max	25V	20V
IF, max	100mA	35mA
IR, max	1 μ A	100 μ A
Ptot, max	250mW	250mW
CD, max	5pF	10pF

Some 'DUS's are: BA127, BA217, BA218, BA221, BA222, BA317, BA318, BAX13, BAY61, 1N914, 1N4148.

Some 'DUG's are: OA85, OA91, OA95, AA116.

- 'BC107B', 'BC237B', 'BC547B' all refer to the same 'family' of almost identical better-quality silicon transistors. In general, any other member of the same family can be used instead.

BC107 (-8, -9) families:

BC107 (-8, -9), BC147 (-8, -9), BC207 (-8, -9), BC237 (-8, -9), BC317 (-8, -9), BC347 (-8, -9), BC547 (-8, -9), BC171 (-2, -3), BC182 (-3, -4), BC382 (-3, -4), BC437 (-8, -9), BC414

BC177 (-8, -9) families:

BC177 (-8, -9), BC157 (-8, -9), BC204 (-5, -6), BC307 (-8, -9), BC320 (-1, -2), BC350 (-1, -2), BC557 (-8, -9), BC251 (-2, -3), BC212 (-3, -4), BC512 (-3, -4), BC261 (-2, -3), BC416.

Resistor and capacitor values

When giving component values, decimal points and large numbers

of zeros are avoided wherever possible. The decimal point is usually replaced by one of the following abbreviations:

p (pico-) = 10^{-12}
 n (nano-) = 10^{-9}
 μ (micro-) = 10^{-6}
 m (milli-) = 10^{-3}
 k (kilo-) = 10^3
 M (mega-) = 10^6
 G (giga-) = 10^9

A few examples:

Resistance value 2k7: 2700 Ω .
 Resistance value 470: 470 Ω .
 Capacitance value 4p7: 4.7 pF, or 0.000 000 000 47 F...
 Capacitance value 10n: this is the international way of writing 10,000 pF or .01 μ F, since 1 n is 10^{-9} farads or 1000 pF.
 Resistors are $\frac{1}{4}$ Watt 5% carbon types, unless otherwise specified. The DC working voltage of capacitors (other than electrolytics) is normally assumed to be at least 60 V. As a rule of thumb, a safe value is usually approximately twice the DC supply voltage.

Test voltages

The DC test voltages shown are measured with a 20 k Ω /V instrument, unless otherwise specified.

U, not V

The international letter symbol 'U' for voltage is often used instead of the ambiguous 'V'. 'V' is normally reserved for 'volts'. For instance: $U_b = 10$ V, not $V_b = 10$ V.

Mains voltages

No mains (power line) voltages are listed in Elektor circuits. It is assumed that our readers know what voltage is standard in their part of the world! Readers in countries that use 60 Hz should note that Elektor circuits are designed for 50 Hz operation. This will not normally be a problem; however, in cases where the mains frequency is used for synchronisation some modification may be required.

Technical services to readers

• **EPS service.** Many Elektor articles include a lay-out for a printed circuit board. Some — but not all — of these boards are available ready-etched and predrilled. The 'EPS print service list' in the current issue always gives a complete list of available boards.

• **Technical queries.** Members of the technical staff are available to answer technical queries (relating to articles published in Elektor) by telephone on Mondays from 14.00 to 16.30. Letters with technical queries should be addressed to: Dept. TQ. Please enclose a stamped, self addressed envelope; readers outside U.K. please enclose an IRC instead of stamps.

• **Missing link.** Any important modifications to, additions to, improvements on or corrections in Elektor circuits are generally listed under the heading 'Missing Link' at the earliest opportunity.

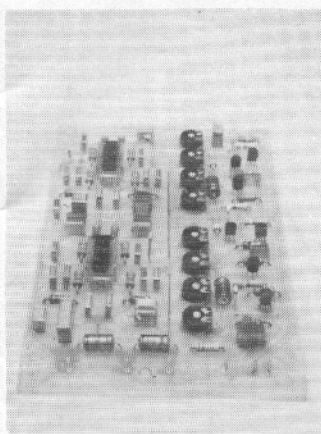

The **elektor equaliser** is a so-called octave equaliser, whereby the gain within each octave can be individually varied. In PA systems, for instance, this unit can be used to obtain a flat frequency response by presetting the individual gain controls.

Alternatively, the unit can be used as a powerful weapon with which to modify a system's frequency response as required, and for this application it is recommended to use rotary potentiometers instead of presets.

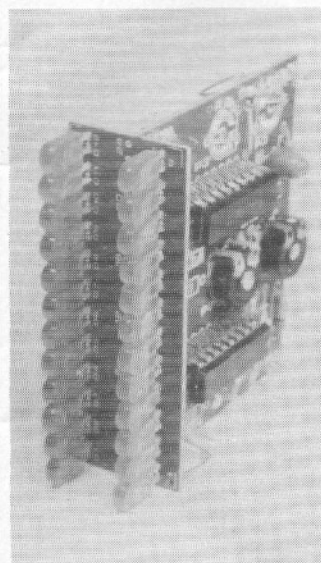

Only one IC and a few discrete components are required to construct a **peak programme meter drive** circuit that will provide a logarithmically-scaled DC indication of the peak AC input level. The unit can be combined with the **UAA 180 LED voltmeter** to make a compact, two-channel PPM.

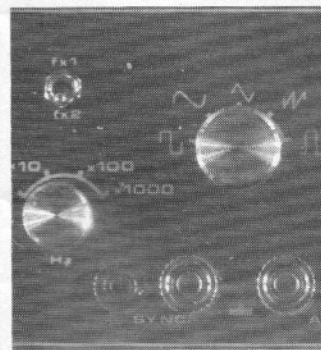

The **simple function generator** was designed to strike the right balance between cost and performance: it offers a wide range of waveforms, is simple to build and calibrate, and is extremely easy to operate.

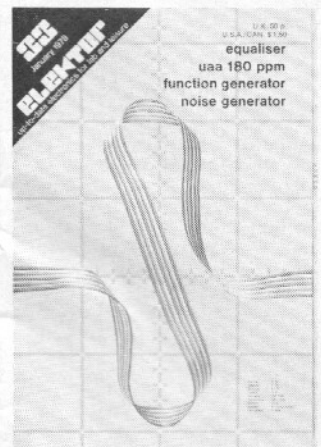

This month's cover was inspired by the proliferation of audio signal generating, modifying and measuring equipment in this issue, in combination with the continuing story of the SC/MP - for which 'flat cable' is an extremely useful connecting medium.

contents

selektor	1-01
Artificial pancreas?	
CMOS noise generator	1-05
Just twelve months ago, issue 21 contained an article on the digital synthesis of noise using a pseudo-random binary sequence generator. The circuit used 10 TTL ICs and soaked up some 260 mA from the power supply. Now, inevitably, there is a single IC that does the same job, consumes only one-fourteenth of the power, gives three times the output signal and occupies about one-twentieth of the volume.	
elektor equaliser	1-08
TAP-tip	1-16
electronic open fire - S. Kaul	1-16
peak programme meter	1-17
UAA 180 LED voltmeter	1-20
experimenting with the SC/MP (3)	1-24
H. Huschitt	
This, the third article in the SC/MP series, introduces the memory extension card, which, in addition to containing 3/4 k of RAM and 1/2 k of PROM, also houses the multiplexer and priority encoder. The latter hardware allows the SC/MP to handle interrupt requests from more than one peripheral device. The article also examines the software involved in interrupt operations.	
missing link	1-31
ejektor	1-32
third octave filters	
formant - the elektor music synthesiser (7) ..	1-34
C. Chapman	
The ADSR (Attack-Decay-Sustain-Release) shaper described in this article can be used to control the VCA and VCF to impart a wide range of tone colour and amplitude dynamics to the VCO waveforms.	
simple function generator	1-40
market	1-47
TUP-TUN-DUG-DUS	E-15
advertiser's index	E-24

C.T.S. 20 CHATHAM ST. RAMSGATE KENT TEL. THANET 54072

TRANSISTORS, DIODES, RESISTORS, TRIACS, CAPACITORS, TRANSFORMERS, THYRISTORS, T.T.L., LINEAR AND CMOS, I.C.S., LEDS, PANEL AND MULTIMETERS, KNOBS, CONNECTORS, VALVES, BRIDGE REC'S., ALUMINIUM AND DIECAST BOXES, SPEAKERS AND MUCH MORE.

All prices include VAT at 8% or 12½% & P&P C.W.O. only.

AC125/6/7/8	20p	BC212/3/4	12p	2N2904/5/6/7	17p
AC176/187/188	28p	BCY70/71/72	15p	2N2926 (green)	12p
AD161/162	40p	BD131/132	40p	2N3053	25p
161/162 matched	1.00p	BD139/140	40p	2N3054/55	50p
AF115/6/7	30p	BF194/5/6/7	13p	2N3702/3/4	11p
AF139/289	42p	BF199	24p	2N3903/4/5/6	16p
BC107/108/109	9p	BFR39/79	30p	2N2646	50p
BC147/8/9	10p	BFY50/51	16p	T1S43	30p
BC157/8/9	11p	BFX29/84/85	30p	MPF102/105	42p
BC167/8/9	11p	MJE2955	90p	2N3819	28p
BC177/8/9	17p	MJE3055	65p	2N5457/8/9	40p
BC182/3/4	11p	TIP29A/30A	48p	ZTX107	14p
BC208	11p	TIP41A/42A	70p	ZTX300/500	16p
IN4001/2/3/4	5p	Bridge Recs		LM741	25p
IN4006/7	9p	200V 1A	26p	LM747	70p
1N5402 (3A 100V)	15p	400V 1A	33p	LM301A	60p
1N5408 (3A 1000 V)	22p	200V 2A	46p	LM308N	1.30p
BY127	15p	400V 2A	54p	LM380	95p
BYX94 (1250V 1A)	6p	200V 6A	90p	NE555	35p
OA90/91/95	9p	400MW zeners	9p	NE556	1.00p
OA79/81	12p	1.3W zeners	15p	CA3130T	1.20p
S.C.R.S. 50V 100V 400V		(all values)		CA3140S	1.20p
T05 1A 25p 27p 46p		BR100 or ST4	25p	TAA550B	35p
T066 3A 35p 40p 55p		400V Triacs		LM318A	2.65p
STUD 7A 55p 65p 75p		T05 2A	65p	CA3130E	1.80p
		T0220 8A (R.C.A.)	80p	TB810-S	2.20p

Special Offers.
C122M 8A 600V Thyristors (TO220) @ 70p
Voltage Regs 7800 Series Plastic @ 1.40p
Pos or Neg 5V 12V 15V 18V

LM309K 1.45p LM317 3.35p
¼ and ½ watt 5% carbon film resistors E12 2p
D.I.L. Sockets 8 pin 12p 14 pin 14p 16 pin 16p .125" 15p 27p 72p
For T.T.L. See previous Advertisement

ALL COMPONENTS BRANDED AND NEW. LET US QUOTE FOR YOUR PROJECT REQUIREMENTS, JUST SEND S.A.E. WITH YOUR LIST - NO MINIMUM ORDER CHARGE.

ELEKTOR 1977 ISSUES

In 1977 we published over 200 different designs in Elektor which included approx. 29 Audio articles, 6 Car articles, 18 Design ideas, 18 Domestic circuits, 10 Fun, games and model building Circuits, 18 Information articles microprocessors 13 music circuits, 12 Paranormal circuits 13 Power supply circuits, 17 R.F. circuits, 37 Test and Measuring Equipment circuits, 7 Time, Timers and counters, circuits, and 11 miscellaneous designs

Due to our increased circulation and popularity of these articles, only limited amounts of 1977 back issues are available so please order your set of issues 21-32, while our stocks last we would hate to disappoint you

A more detailed cumulative index for 1977 is published in the December 1977 issue number 32. A list of available printed circuit boards and their prices can be found in the EPS list at the front of this issue.

TEST EQUIPMENT ELECTRONICS

All prices include VAT

DIGITAL MULTI-METERS

NEW SINCLAIR PDM 35 POCKE-T DMM £31.95 C/P 45p

SINCLAIR DM2
World famous digital multimeter AC/DC volts & current 1 mA/0.1 A Resistance 1 to 20 M accuracy 1% 1 digit
MULTI TESTS (UK C/P 50p)
Featuring AC/DC volts, DC current, resistance ranges etc.
TMK 500 30 k per volt £18.95
LT101(T) 1 k/volt sensitivity £6.95 LT1-2 20 k/volt £10.95
T12 5 p per volt £7.95
C7200 20 k/volt DC volts up to 6 kV, resistance up to 20 Mega £16.95
7081 50 k/volt (full) 10 ranges AC volts, 12 ranges DC volts, 10 ranges DC current, 0/25 A to 0/10 amps, 4 ranges resistance TO 16 Meg £22.50

880R k/volt £27.25 microtest 80 £16.15
360TR 100 k/volt 23 ranges plus transistor checker £32.50
General Mod. 63 ICE-signal injector wide range output £7.50 (C/P 20p)
LB1 PNP/NPN transistor checker 100/alpha/beta £21.50 (C/P 50p)
clamp meter 0-600V/200A/1.5 kohm £29.50 (C/P 35p)

STOCKISTS FOR SCOPEX, LEVELL, LAWTRONICS, AVO, GOULD ADVAN CED ETC.

Scopes/generators/probes/DMM's etc. range always in stock for callers
TRADE AND EXPORT SUPPLIED
Building your own speaker systems? Large range of speakers and kits Also microphones and mixers from stock, see catalogue.

IC AMPLIFIERS

SN76023ND	4 watt	8 ohms	£1.50
SN76033N	6 watt	4 ohms	£2.00
T8AR00	5 watt	15 ohms	£1.40
T8AR10	7 watt	4 ohms	£1.40
T8AR20	2 watt	8 ohms	£1.25
AP35P	35 watt	8 ohms	£8.50

CLOCKS (with data)

MM5314 12/24 HR 4/6 digits LED (plex) display £4.95
MM5316 as above for monolithic LED displays £3.95

DIGITAL CHIPS (with data)

MC14553 0-999 decimal counter £4.78
ICL7107 3 1/2 digit digital multimeter basic (LED) £15.00
ICL7106 3 1/2 digit digital multimeter basic (LCD) £15.50
TV GAMES (with data)

AY-3-8500 8 games/scoring/sound £7.99
ELECTOR PC PANEL £2.05
DISPLAYS (with data)

Browne 8 1/2 digit MPX £1.85
LCD 3 1/2 digit for DMM's £10.75
Panaseq 8 digit MPX (180V) £4.50
8870L numerical tube (180-200 V) £1.67
Texas 4 + 5 digit MPX per pair £1.85
ZM1080 numerical tube (180-200 V) £1.67

CRYSTALS

1 MHz HC6 £2.25
100 kHz + 1 MHz HC6U £2.25
2 MHz, 4 MHz HC6U pair £3.50
10.7 MHz 7 stage crystal 1F £7.00
Filter 25 kHz bandwidth £7.00
(Large range of LEDs/7 segment etc. displays in stock for callers)

KEYBOARD 19 switches, gold plated wiping action 8.3 x 7.1 CMS 7 for £1.50 price per 10 £2.50

REED SWITCHES Aims single make 1.9 x 2.6 CMS price per 10 £2.50

JOYSTICK CONTROL High quality TV Sound from your fitted 4 x 100% Lin ganged FM Tuner. Tuner Unit £3.50 C/P 35p with easy mod's sheet £2.95

WELLER 8200D PK Dual heat Solder Gun Kits £9.95 C/P 55p.
2N3055A (120 volt 3 amp) Fully guaranteed 3 for £1.00 10 for £3.00 100 for £27.50 1000 for £250.00

ALSO IN STOCK

1 CM square silicon cells ½ volt 5 MA 5 for £2.60
Condenser Mic. capsules with fet preamp £1.80
600mW glass enclos. LDR £3.25
LP1179/LP1171 Mullard AM/FM modules (front end and IF strip £7.30
Data inch resist pens 1 blue, 1 red £2.00
Printed circuit kits £2.80. Ultrasonic Transducers £7.50 per pair

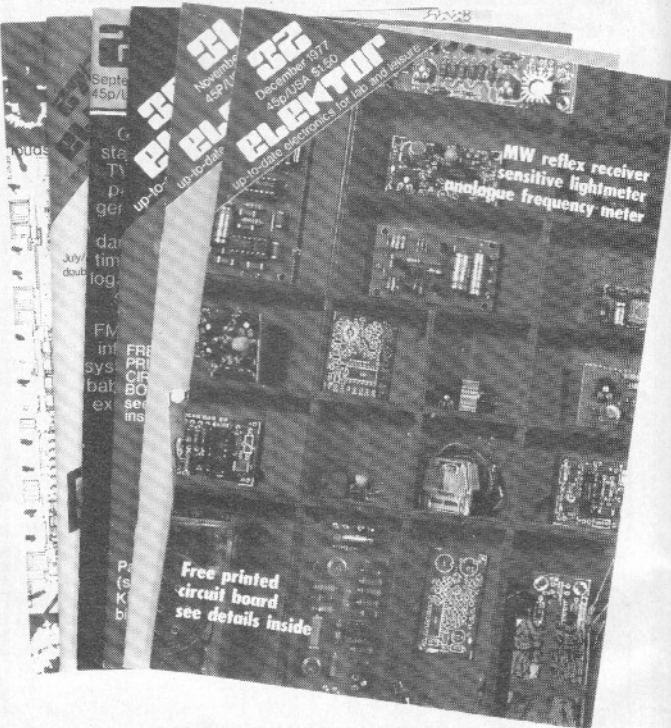

AUDIO ELECTRONICS

301 EDGWARE RD., LONDON W2 1BN
01-724-3564. OPEN 9-6, MON-SAT.

FREE CATALOGUE

SEND STAMPED (12" x 6" U.K.)
ADDRESSED ENVELOPE (MIN 9" x 6")
FOR YOUR COPY NOW

TEST EQUIPMENT • SPEAKERS • COMPONENTS
MICROPHONES • MODULES • IC'S • DISPLAYS
CALL IN AND SEE FOR YOURSELF.

selektor

Artificial pancreas?

Although roughly 25% of the population are susceptible to diabetes, only 3% actually contract this much feared illness; of these diabetics approximately 30% (i.e. roughly 1% of the total population) are dependent upon insulin (diabetes mellitus), whilst the remaining 70% can be treated by means of a carefully regulated diet and, in some cases, by pills which reduce the level of sugar in the blood.

The illness is caused by a failure of the pancreas to produce sufficient insulin, a substance which is of crucial importance for carbohydrate metabolism. Lack of insulin diminishes the ability of the muscles and other tissues to utilise sugar for the purposes of nutrition, so that the sugar simply builds up in the bloodstream until it is excreted in the urine. What actually precipitates the onset of the disease is not yet fully understood, although it is known that the cells in the pancreas called the islets of Langerhans cease to function. Since insulin is no longer provided by the pancreas, it therefore becomes necessary for the diabetic to administer the insulin to himself by means of injections. It is possible to recognise the diabetic by the set times during the day at which he eats, and also by the small packet of sugar or glucose sweets which he always carries. The reason for this latter pre-

caution is that in addition to suffering from too much sugar in his blood, i.e. from a shortage of insulin, the second dangerous state for a diabetic is to have too much insulin - a condition which, unless remedied by an intake of sugar, can quickly lead to the patient falling into a coma.

The discovery in 1922 by the Canadians Banting and Bert that insulin could be isolated and extracted from the pancreas of pigs and cattle meant that diabetes was no longer a fatal illness. Since then types of insulin have been developed which have reduced the number of injections needed from between three to six a day to just one a day. However, scientists have continued to seek a system which would automatically monitor the blood-sugar level of the diabetic and regulate the amount of insulin being administered; in other words, produce an 'artificial pancreas'.

At present the concentration of sugar in the blood of a diabetic is ascertained by means of blood samples which change the colour of certain chemicals, the particular colour indicating the amount of sugar being carried by the bloodstream to the muscles and other tissues.

Since it is rather unpleasant for the patient to have to take repeated samples of blood, the quantity of sugar present in the urine can also serve as a suitable measure. Thus until now the diabetic has attempted to balance the relative amounts of sugar and insulin by means of injections and a strictly controlled diet, whilst regularly checking his blood-sugar level by means of the above mentioned blood and urine tests.

However, these methods as well as being somewhat awkward and unpleasant for the patient are also fairly approximate, as is evinced by the imbalance found in the metabolism of large numbers of diabetics. Fortunately, research into the treatment of the diabetic is continuing, and recently several different teams of researchers have come up with developments which, taken together, could prove a first step on the road to an artificial pancreas.

Automatic insulin drip

At Siemens Erlangen (Germany) a research team working under Dr. Manfred Franetzky have developed a miniature 'pump', which allows very small amounts of highly concentrated insulin to be fed continuously into the bloodstream of the diabetic (see figures 2a to 2c). The pump is scarcely larger than a matchbox, and weighs approximately 120 grammes when filled with sufficient insulin for nine months. The amount of fluid which is released can be varied between 0.1 μ l and 10 μ l per hour. The insulin requirements of the diabetic vary throughout the day, showing strong peaks around 9.00 and 14.00. It appears from experiments which have been carried out that, although the needs of the patient vary considerably in the course of the day, each diabetic nonetheless has his own particular 'programme' of requirements. As long as an implantable sensor which would monitor the changes in the diabetic's sugar level remains unavailable, the possibility of a pre-programmed insulin dosage (using e.g. a clock IC) is being investigated.

Figure 1. Dr. Kaiser demonstrates the use of the laser absorption spectroscope, which can be used to measure the levels of various organic compounds in the bloodstream, for example polypeptides, urea, cholesterol and, of course, glucose. Although having to 'kiss' the test prism may seem a strange procedure, it is considerably less unpleasant than having a blood sample taken, and the measurement is 1000 times more accurate. The measurement could also be made many times a day.

Figure 2a. The insulin dosage pump from Siemens. This is able to deliver extremely accurately controlled amounts of insulin, and has a reservoir containing up to nine months' supply.

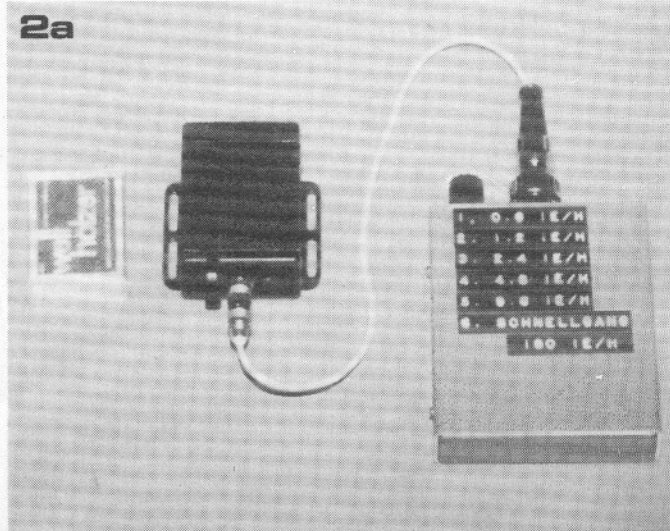
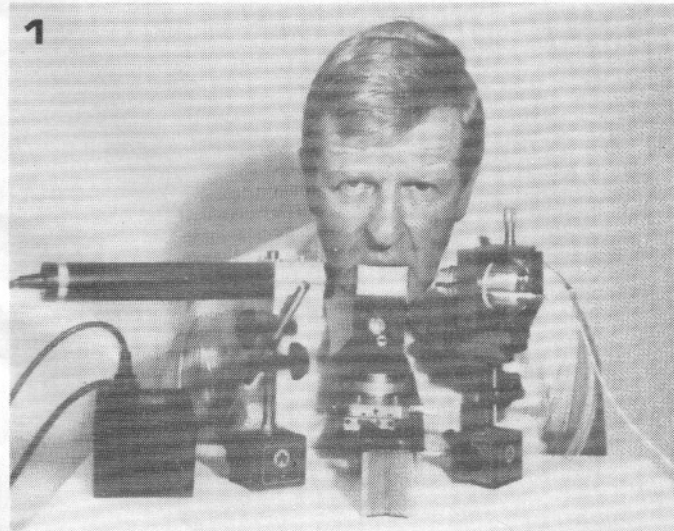



Figure 2b. The insulin pump and control unit. Since a diabetic's insulin requirements vary throughout the day, the possibility of a clock-controlled dosage programme is being considered.

Figure 2c. Rear view of the control unit.

Figure 3. Cutaway diagram of the glucose electrode developed by Laine, Schultz, Thomas, Sayler and Bergmann.

Figure 4. Absorption spectra of various compounds found in the bloodstream.

Blood-sugar monitor

A great deal of excitement was generated in the field of diabetic research last year by two breakthroughs in the monitoring of blood-sugar levels. A Japanese research group announced the development of an 'enzyme electrode' for direct monitoring of sucrose levels in the bloodstream and an American group announced the development of a 'glucose electrode'.

This latter is of particular interest, since it is fairly compact (see figure 3), produces an output voltage proportional to the glucose level in the bloodstream, and at first sight would appear to be ideal for implantation. Unfortunately, the electrode is unsuitable for long-term use, since, when placed in the bloodstream, it quickly becomes choked with tissue shed from the blood-vessel walls, and also encourages the formation of blood clots.

Laser absorption spectroscopy

Another interesting approach to monitoring the level of glucose (and other compounds) in the blood has been developed by Dr. Kaiser of the Max Planck Institute in Munich.

Laser absorption spectroscopy utilises the principle that compounds selectively absorb light of a particular wavelength. It is therefore possible to identify and quantify specific compounds, such as glucose, in the blood, by measuring the absorption of light of the appropriate wavelength.

Figure 4 shows the absorption spectra for various compounds in the blood. The absorption wavelength of glucose is around 10 microns. This wavelength can conveniently be provided by a carbon-dioxide laser, which covers the range 9.15 to 10.9 microns. The interesting thing about this technique is that it does not require a blood sample to be taken. The absorption measurement can be taken through the skin at any point where the blood flow is near the surface and fairly rapid. The lips are particularly suitable and to take a measurement the subject merely presses his lips against

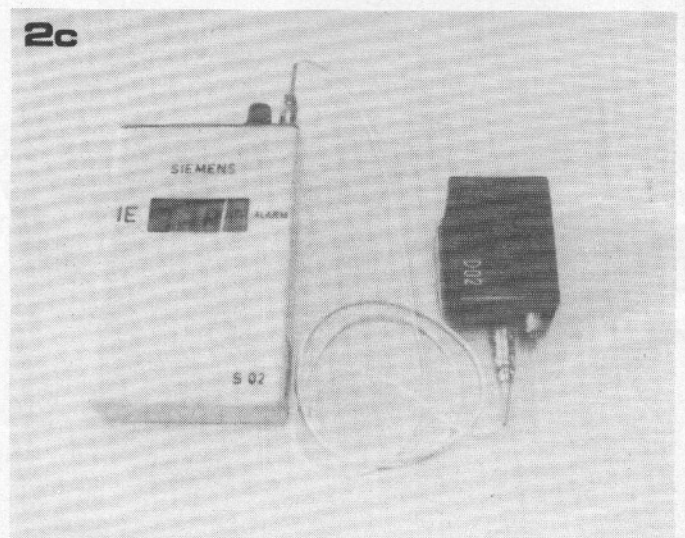
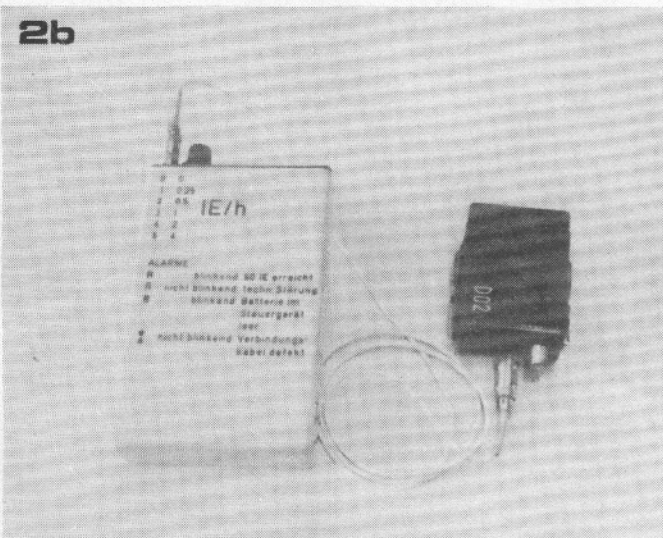
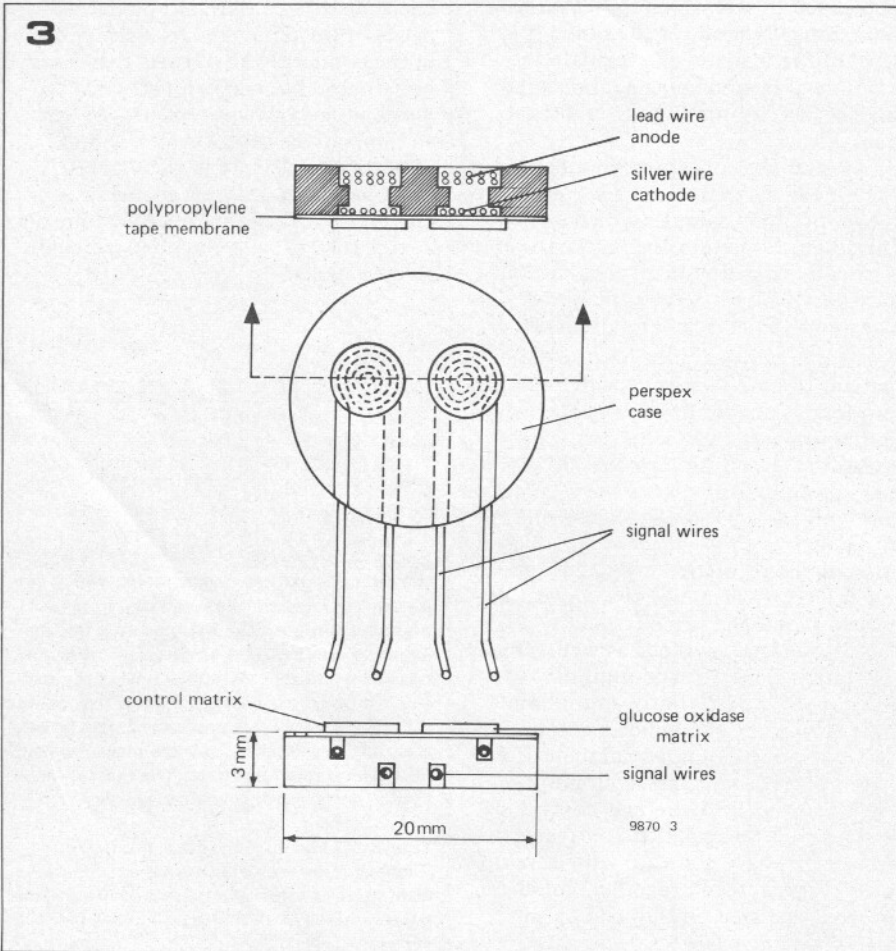



the test prism of the spectroscope. Dr. Kaiser is shown demonstrating this technique in figure 1.

Figure 5 shows the arrangement of the spectroscope. Infra-red light from the laser is split, by a semi-silvered mirror, into two beams which are passed through two prisms, a reference prism and the test prism. The beams are then recombined and focused onto a photo-detector. The two beams are alternately interrupted by a mechanical chopper, which allows comparison of the light passing through the two prisms. When the lips are pressed against the test prism, absorption of the laser light by glucose in the bloodstream occurs. Comparison of the test and reference light beams by the potosensor allows the glucose level to be measured. Apart from its use in the treatment of diabetes, the laser absorption spectroscope allows many other compounds in the bloodstream to be measured simply by choosing the appropriate laser wavelength, for example polypeptides, cholesterolin and urea. The onset of diseases characterised by the appearance,

in the bloodstream, of specific compounds could thus be detected at an early stage by a routine test. The necessity for an expensive and time-consuming chemical analysis of a blood sample would be obviated. The laser absorption spectroscope can also differentiate between glucose and ethanol, which was previously difficult because of their very similar absorption wavelengths (see figures 6a and 6b). However Dr. Kaiser's method effectively gives a much more 'expanded' wavelength scale (figure 6c) which allows distinction between the two compounds. The laser absorption spectroscope may therefore also find application in drunken driving cases, as an alternative to the controversial blood sample and the possibly unreliable urine test.

Artificial pancreas

The ultimate result of all this research must be to produce an 'artificial pancreas' which can be implanted in the body. This would free the insulin-dependent diabetic from the worry of administering his own insulin injections and would also tailor insulin dosage much more closely to the body's needs. The laser absorption spectroscope and the insulin pump are both valuable steps in this direction. Speculating on future developments, the next possibility might be an implantable insulin pump with several years' supply of insulin, fitted with a microprocessor based control unit. This would initially be programmed to deliver insulin in accordance with calculations of the user's insulin demand based on blood-sugar measurements taken over a period of time. After implantation, the programme could be updated in accordance with blood-sugar

measurements obtained daily using a laser absorption spectroscope, the data being communicated to the implanted pump unit by radio or induction loop transmitter.

A reliable power source for the unit would be a major problem, but modern developments in long-life chemical batteries and implantable nuclear power sources may provide a solution. Alternatively, it might be possible to equip the pump unit with rechargeable batteries, which could be charged each night using a coil placed against the chest wall to induce current in a pickup coil inside the implanted unit. The ultimate ideal would be to have an implanted blood-sugar monitor, so that this information could be fed continuously to the pump control unit. However, at this stage it is not clear how this would be accomplished, since the glucose electrode sensor lacks long term reliability, and the laser absorption spectroscope is both complex and bulky.

Acknowledgements

It is an established fact that the number of scientific fields in which electronics is providing valuable assistance is continually growing. This article is intended to introduce our readers to an area of research which may stimulate the interest and perhaps even the ingenuity of the electronics engineer. For their cooperation in providing information for this article we wish to thank:
 Dr. Ing. Manfred Franetzky, Siemens AG., Erlangen
 Prof. Dr. K.D. Hepp, Med. University, Munich
 Dr. Nils Kaiser, Max-Planck Institute, Munich (Garching)

4

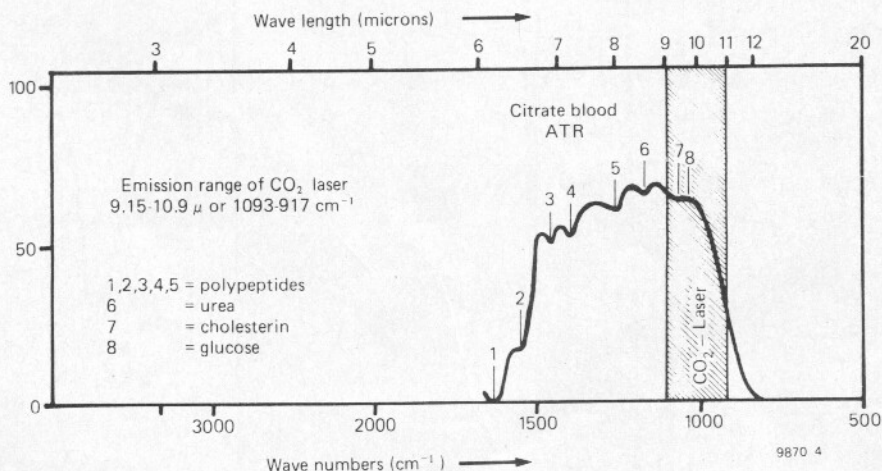



Figure 5. Arrangement of the laser absorption spectroscope developed by Dr. Kaiser.

Figure 6. The laser absorption spectroscope allows extremely fine wavelength discrimination to be achieved, which can, for example allow glucose to be distinguished from ethanol, even though their absorption wavelengths are similar.

References:

'Continuous Extracorporeal Monitoring of Animal Blood Using the Glucose Electrode', Laine, Schultz, Thomas, Saylor and Bergmann, *Los Angeles Diabetes*, Febr. 1976, vol. 25, no. 2 pp. 81-89

'Laser Absorption Spectroscopy with an ATR-Prism', Nils Kaiser, *Congres Diabetologie in Geneva*, Sept. 1977

'Enzyme Electrode for Sucrose', Ikuo Satoh, Isao Karube and Suichi Suzuki, *Biotechnology and Bioengineering*, vol. 111, 1976, pp. 269-272.

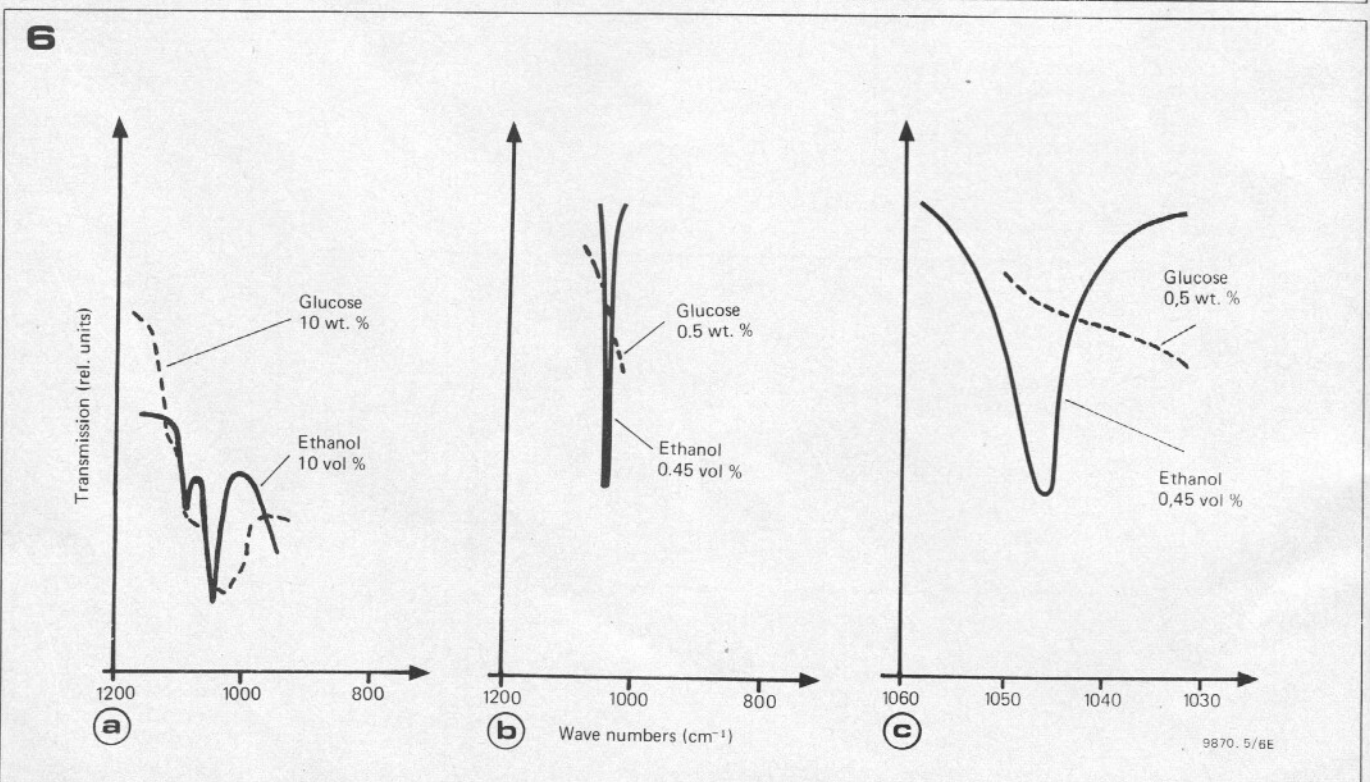
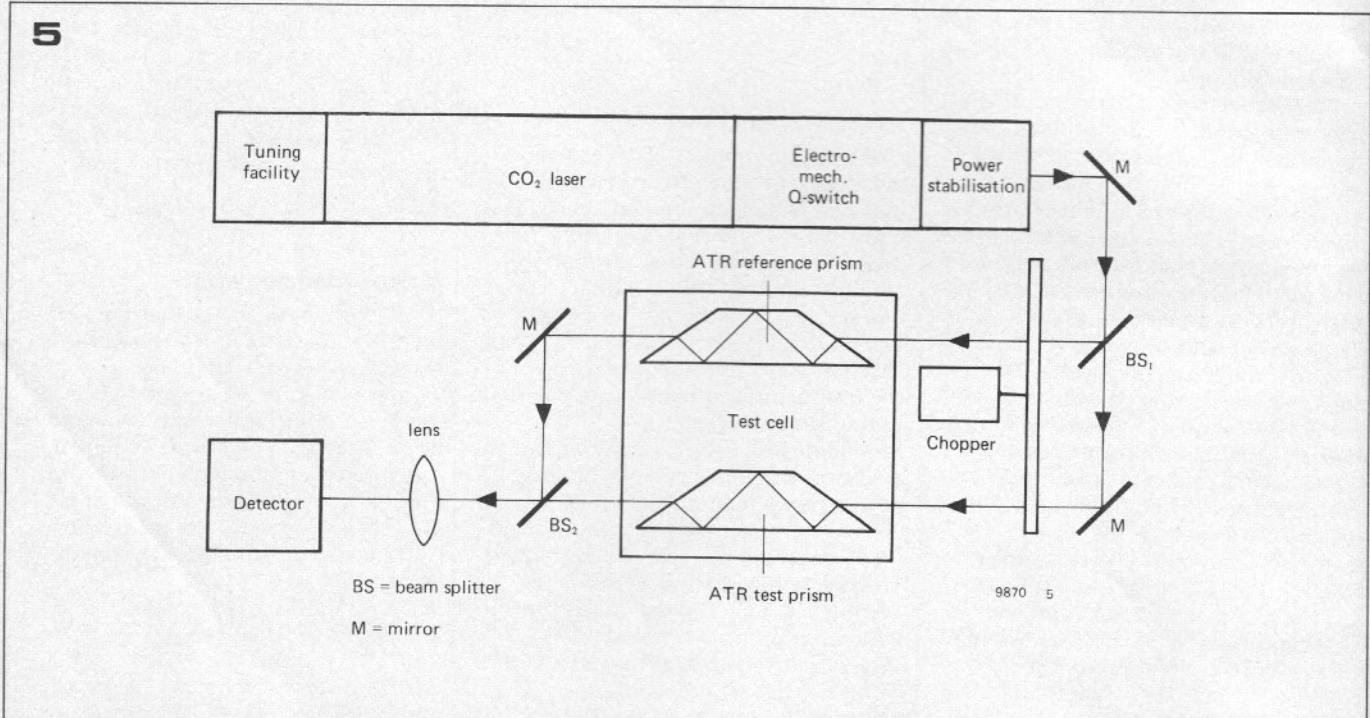

CMOS noise generator

The generation of noise using digital techniques was discussed extensively in the January 1977 article, and for a complete theoretical treatment of the subject readers are referred to this issue. The National Semiconductor digital noise generator IC is a complete pseudo-random binary sequence generator on a single chip. It contains a clock pulse generator, 17-bit shift register, exclusive-OR feedback and anti-latch-up gating. The pseudo-random noise output of the MM 5837 has a cycle time of 131,071 clock periods.

The clock frequency of the MM 5837 is not externally programmable, but may lie between 55 kHz and 119 kHz at a supply voltage of 14 to 15 V. This means that the pseudo-random sequence cycle time may lie between 2.4 s and 1.1 s, and the 3 dB point of the power density spectrum may lie between 24 kHz and 56 kHz. The clock frequency is, moreover, extremely dependent on supply voltage. However, with a 15 V supply, the clock frequency tolerance means that the spectral density of the noise output will be between 1.2 and 2.4 lines per Hertz, which is certainly high enough for the noise spectrum to be considered as continuous for all practical purposes.

Noise generator circuit

Figure 1 shows the complete circuit of a noise generator. This consists of the MM 5837 noise generator IC, a 3 dB/octave 'pink noise' filter, and a bandpass filter with fixed, third-octave bandwidth and adjustable centre frequency. The TTL version of the noise generator did not include these two filters, but readers who already have the TTL circuit can add the filters simply by omitting IC1 and feeding the output of the TTL circuit into point A1. For readers building a noise generator 'from scratch' however, it is recommended that the MM 5837 IC be used.

Pink noise filter

As mentioned in the January 1977

Just twelve months ago, issue 21 contained an article on the digital synthesis of noise using a pseudo-random binary sequence generator. The circuit used 10 TTL ICs and soaked up some 260 mA from the power supply. Now, inevitably, there is a single IC that does the same job, consumes only one-fourteenth of the power, gives three times the output signal and occupies about one-twentieth of the volume.

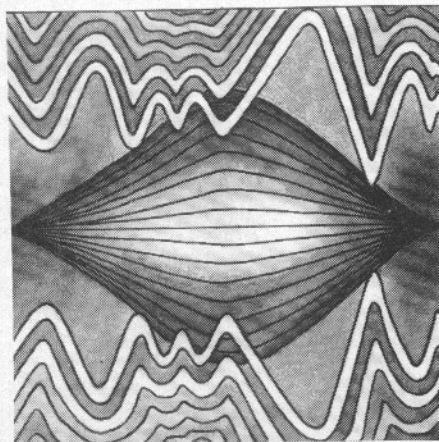

article, if white noise is fed to a band-pass filter with a constant Q-factor (constant octave bandwidth) then as the centre frequency of the filter is increased the RMS output voltage will increase at 3 dB/octave. If, as is often the case, third-octave filters are used to make selective frequency response measurements on a system with a white noise input, this 3 dB/octave rise can be a nuisance, since a system with a flat frequency response would apparently have a +3 dB/octave slope when measured in this way.

The solution is to use noise whose output amplitude falls at 3 dB/octave, to compensate for this effect - so-called 'pink noise'. This is achieved by feeding the (approximately) white noise output of the MM 5837 to a passive, lowpass filter with a slope of -3 dB/octave. Since 'normal' filters usually have slopes in multiples of 6 dB/octave, a 3 dB/octave filter must be approximated in 'staircase fashion' using a series of 6 dB/octave filters with different centre frequencies, R1 to R10 and C2 to C12 in figure 1. Of course, the mathematical analysis of the filter is rather more complex than this simple explanation would indicate!

The output of the 3 dB/octave filter is buffered by an emitter follower T1, the output of which is fed to an operational amplifier with a gain of 10, IC2. The pink noise output A2, from the wiper of P1, has sufficient amplitude to drive most audio equipment.

Third octave filter

Feeding pink noise through a filter having a bandwidth of one-third of an octave gives an output signal known, not surprisingly, as third-octave noise. An ideal third-octave response is shown in figure 2a. Within the passband there is no attenuation of the signal, and outside the passband there is infinite attenuation. In practice, of course, this passband is impossible to achieve, filters with infinite slopes simply do not exist. A good approximation to an ideal bandpass response is illustrated in figure 2b. This is achieved by using two selective filters with slightly different

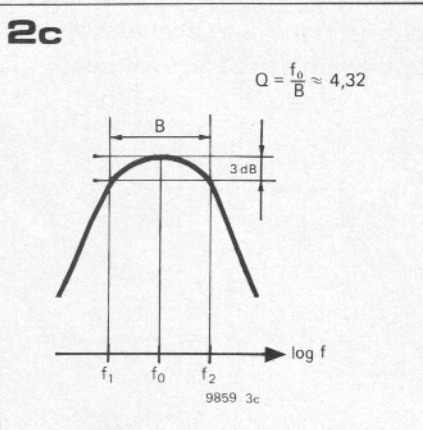
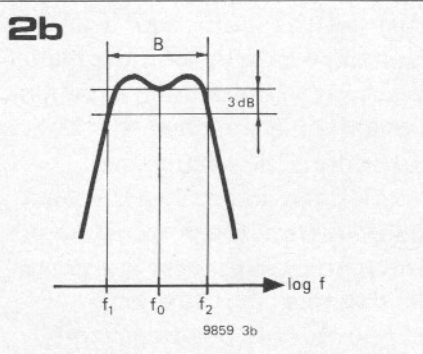
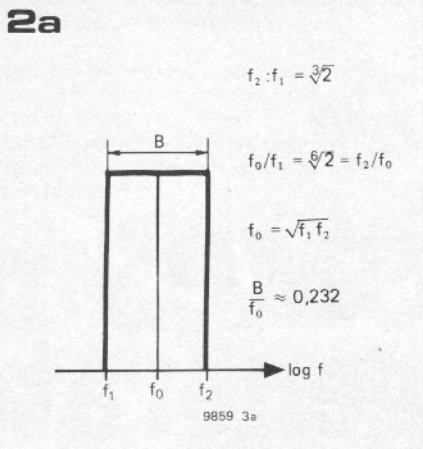
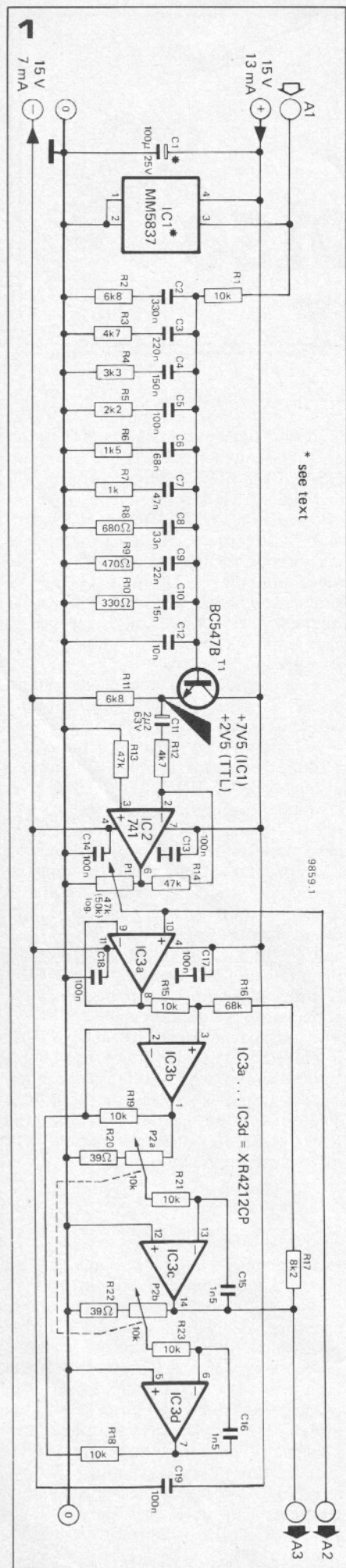

- Parts list**
- Resistors:**
 R1, R15, R18, R19, R21, R23 = 10 k
 R2, R11 = 6k8
 R3, R12 = 4k7
 R4 = 3k3
 R5 = 2k2
 R6 = 1k5
 R7 = 1 k
 R8 = 680 Ω
 R9 = 470 Ω
 R10 = 330 Ω
 R13, R14 = 47 k
 R16 = 68 k
 R17 = 8k2
 R20, R22 = 39 Ω
 P1 = potentiometer 47 k (50 k) log
 P2a/P2b = stereo potentiometer 10 k log
- Capacitors:**
 C1* = 100 μ/25 V
 C2 = 330 n
 C3 = 220 n
 C4 = 150 n
 C5, C13, C14, C17, C18, C19 = 100 n
 C6 = 68 n
 C7 = 47 n
 C8 = 33 n
 C9 = 22 n
 C10 = 15 n
 C11 = 2μ2/63 V
 C12 = 10 n
 C15, C16 = 1n5
- Semiconductors:**
 T1 = BC 547B, BC 107B, BC 147B or equivalent
 IC1* = MM 5837 (National Semiconductor)
 IC2 = 741 (MINI DIP)
 IC3a + IC3b + IC3c + IC3d = XR 4212CP (EXAR) quad op-amp
- * Is omitted if the TTL circuit in Elektor 21, January '77 is used.

Figure 1. Circuit of the new pseudo-random noise generator. IC1 replaces the 10 TTL ICs of the January 1977 circuit! However readers already possessing the TTL version can add the 3 dB/octave and third-octave filters by omitting IC1 and connecting the output of the TTL version to point A1.

Figure 2a. Ideal third-octave bandpass response.

Figure 2b. A good approximation to an ideal response can be obtained using two cascaded selective filters with staggered centre frequencies. However, it is not easy to build a filter with continuously variable centre frequency using this technique.

Figure 2c. The third-octave filter used in the noise generator is a single selective filter with a Q of 4.32, which is realised using a state-variable filter configuration.

Figure 3. Printed circuit board and component layout for the noise generator (EPS 9859).

centre frequency. At the band edges their combined slopes are quite large, whilst within the passband the response is relatively flat. Unfortunately, the filter in the noise generator must have a variable centre frequency, which is difficult to achieve with staggered selective filters — they cannot be made to track with sufficient accuracy. A compromise solution is therefore adopted in the form of a single selective filter with a Q-factor of 4.32 (see figure 2c). The filter circuit used is the so-called state-variable filter. The pink noise signal from the wiper of P1 is fed via a voltage-follower buffer IC3a to the input of IC3b. The state-variable filter is built around IC3c and IC3d; by means of a ganged potentiometer P2, the time constants of the integrators and hence the centre frequency of the filter may be varied. The Q-factor of the filter is determined by feedback to IC3b and is independent of the filter centre frequency. This type of filter is extremely

3

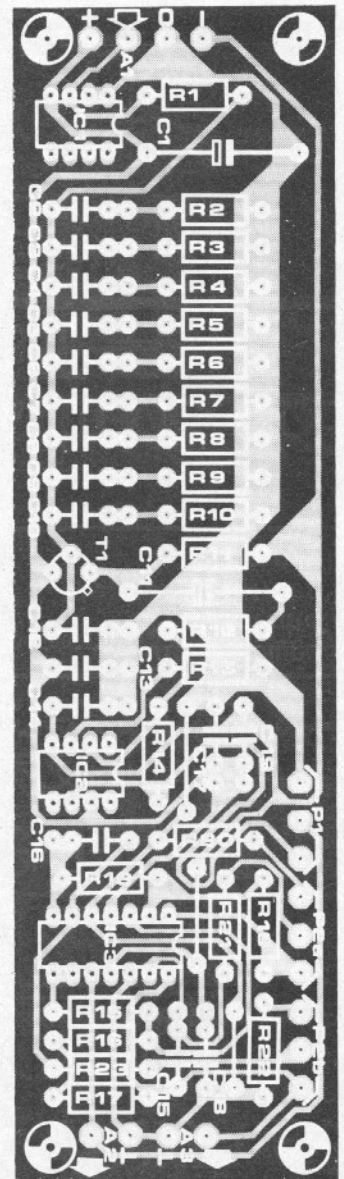
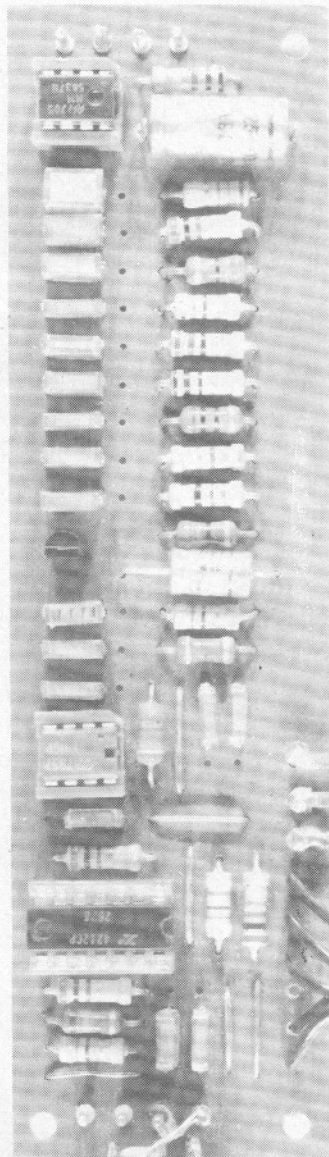
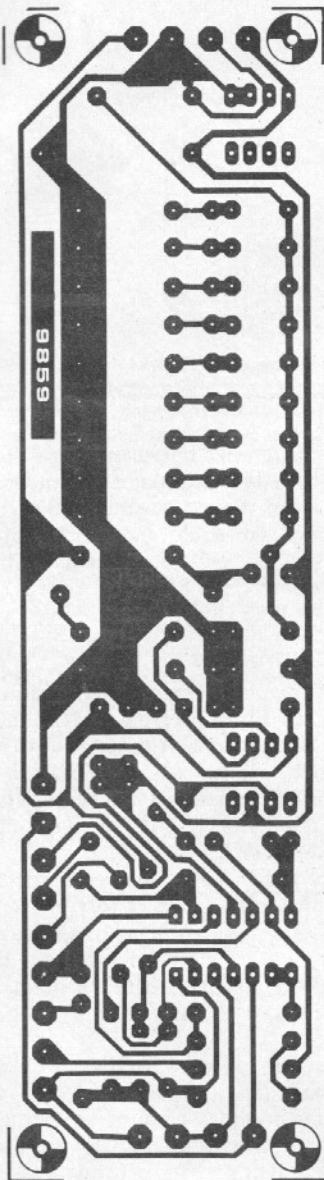

stable over its entire frequency range, which may be adjusted from 40 Hz to 10 kHz approximately, by P2.

The third-octave noise output is available at point A3, the output of IC3c.

Construction

The noise generator and its associated filters are accommodated on a very compact printed circuit board, the track pattern and component layout of which are given in figure 3. If the filter circuits are to be used with the existing TTL noise generator then IC1 and C1 can be omitted, and input A1 is connected direct to the output of N30 on the TTL noise generator board. If the white noise output of the TTL noise generator is not required, which frequently it is not, then several modifications can be made with advantage. Firstly, R5, R6, C2 and C3 of the TTL circuit may be omitted, and the clock frequency can be lowered to about 87 kHz by increasing C1 to 27 n. This

has the effect of increasing the spectral density to about 12 lines per Hertz, which makes the output an even better approximation to a continuous noise spectrum.

A white noise output from the MM 5837 is not provided, for the simple reason that this IC cannot provide white noise over the entire audio spectrum, since the clock frequency is too low. At first sight this may seem a little odd. The basic criterion is that the clock frequency should be 2.2 times greater than the highest required noise frequency. With a worst case clock frequency of 55 kHz it would appear that the MM 5837 satisfies this condition for a noise bandwidth from 0 to 20 kHz. However the noise must also be truly Gaussian, and this criterion is influenced by the noise waveform. With the rectangular pulse waveform produced by the pseudo-random binary sequence generator the clock frequency must be at least 20 times the highest desired noise

frequency, a condition which the MM 5837 cannot satisfy for the entire audio spectrum. The MM 5837 will produce Gaussian noise only up to a few kHz. **M**

Stop Press

Further development work on the noise generator has revealed that the 3 dB/octave filter can be considerably simplified by optimising the circuit parameters. The modifications also double the noise output signal from the filter.

The following component changes are necessary:

Component	New value
R1	= 6k8
R2	= 3 k = 1k8 + 1k2
R3	= 1 k
R4	= 300 Ω = 180 Ω + 120 Ω
C2	= 1 μ
C3	= 270 n
C4	= 94 n = 2 x 47 n
C12	= 33 n
R5 to R10 and C5 to C10 are omitted.	

elektor equaliser

Any assessment of the 'musicality' of an audio system must be purely subjective, since quantitative measurements do not always correlate with subjective experience. Users of hi-fi equipment (naturally enough) often set the amplifier tone controls to give a sound that is most pleasing to their ears, which may not agree with other people's ideas of the best sound.

The same is true when an equaliser is used. Although in theory the intention is to produce a flat frequency response, most users will adjust the response by ear, and even if measuring equipment were used to set up a flat response this would not necessarily give the most pleasing sound.

Nevertheless, an equaliser can provide a degree of control over frequency response that is impossible with conventional tone controls, as will become apparent. Normal tone controls, such as the Baxandall type, consist of a combination of high and low pass filters of the form shown in figure 1a. These operate at the low frequency (bass) and high frequency (treble) ends of the audio spectrum, and have little effect in the middle of the audio range. By varying the impedances Z_1 and Z_2 the filters may be made to either boost or cut the bass and treble relative to the mid-range. The controls may be of the fixed slope type with variable break frequency as in figure 1b or, more commonly, of the variable slope type with fixed break frequency, as shown in figure 1c.

Although these circuits offer an inexpensive form of tone control, they have several disadvantages. Firstly, they operate only at the extremes of the audio spectrum, and secondly, since each control is effective over a wide frequency range, boosting or cutting of narrow bands of frequencies is not possible.

The alternative

Figure 2 illustrates the principle of an equaliser in which the audio spectrum is divided into a number of sub-spectra. The signals within any sub-spectrum may be boosted or cut by up to A dB.

f_1 and f_2 represent the band edges of any sub-spectrum, and the *centre frequency* f_0 is the geometric mean of these two frequencies. The *bandwidth* B

An equaliser consists of a number of tone controls, each covering a specific portion of the audio spectrum. The object is to use these controls to obtain a flat frequency response of the audio reproducing chain.

This article discusses the theory and practice of an equaliser using eight controls. Inductors are used in the filters, however these are not wound components but are simulated electronically.

is the difference between f_2 and f_1 .

On the logarithmic frequency scale shown in figure 2 each sub-spectrum occupies an equal bandwidth of one-third of an octave, i.e. for each sub-spectrum $f_1 = 0.8906 f_0$, $f_2 = 1.225 f_0$ and $B = 0.2318 f_0$.

A compromise

The foregoing represents an almost ideal type of filter offering precise control over the entire audio spectrum, but in practice it would be difficult and expensive to realise. To begin with, no less than thirty controls per channel would be required. Even then, some compromise would be required: filters with infinitely sharp cutoff at the band edges are impossible to realise even in theory — let alone in practice! Filters with very sharp cutoffs are practicable, but require a large number of components.

Some sort of compromise is therefore necessary in a practical design where cost and complexity must be considered. The first step is to reduce the number of frequency bands (and hence the number of controls) to something more practical than thirty. Figure 3 shows the frequency bands covered by the filters used in the Elektor equaliser. The audio spectrum is split up into eight one-octave bands from 44.6 Hz to 11.3 kHz, with no filters being provided above or below this frequency. At first sight it would seem that no control is being exerted over an important part of the audio spectrum. However, since the filters do not have the ideal steep-sided passband characteristic the control response does extend below 44.6 Hz and above 11.3 kHz. In addition, if bass or treble boost or cut is required at the extreme ends of the spectrum it can be applied by a good Baxandall type of tone control before switching in the equaliser.

The second compromise is the use of resonant circuits in the filters. Figures 4 and 5 show the response of two filters set for various degrees of boost and cut, with the ideal rectangular response superimposed. The difference between the two is that the filter of figure 4 has a higher Q than that of figure 5. It is evident that, towards the edges of the

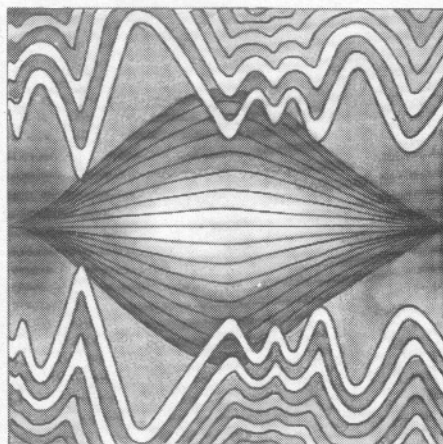

1a

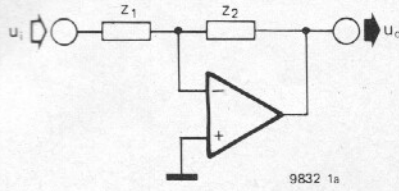

9832 1a

Figure 1a. The Baxandall tone control network consists of an amplifier with frequency-dependent impedances in the input and feedback loops. When these are balanced the frequency response is flat, but when they are unbalanced by altering one of the tone control potentiometers, boost or cut occurs.

Figures 1b and 1c. Baxandall tone control networks can either have variable turnover frequency and fixed slope (figure 1b), or variable slope and fixed turnover frequency; but in either event they control only the extremes (bass and treble ends) of the spectrum.

Figure 2. Frequency response of an 'ideal' equaliser, which divides up the audio spectrum into 30 third-octave sub-spectra. The gain of the system within each sub-spectrum can be varied between +A dB and -A dB.

Figure 3. As figure 2, but now with a coarser division into 8 one-octave sub-spectra. The concept of the Elektor equaliser is based on this division.

1b

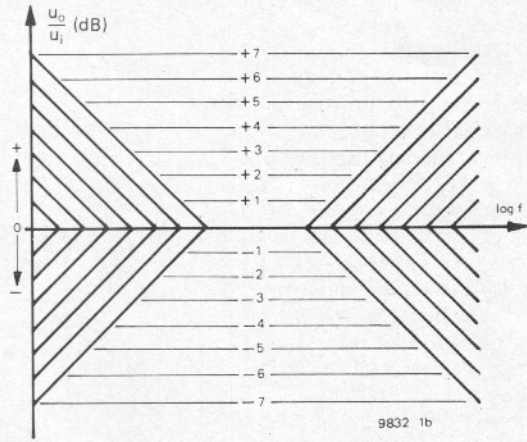

9832 1b

1c

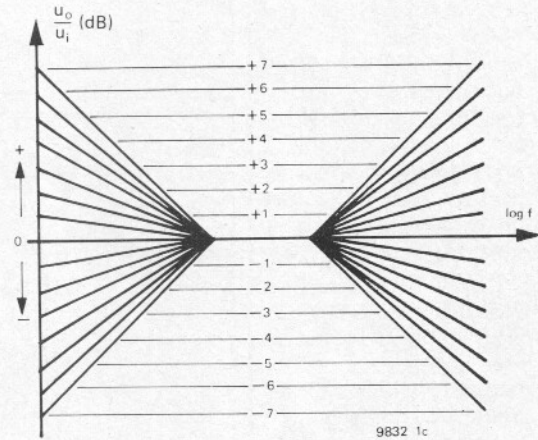

9832 1c

2

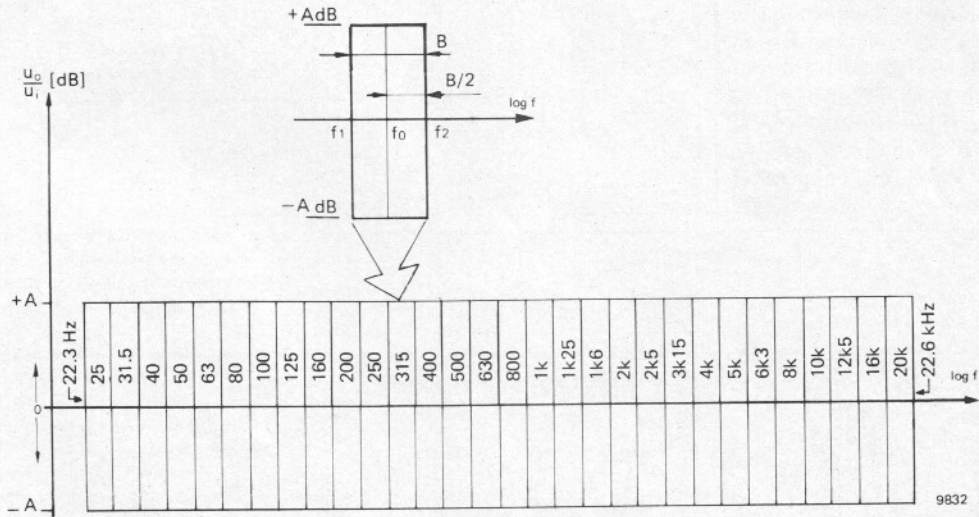

9832 2

3

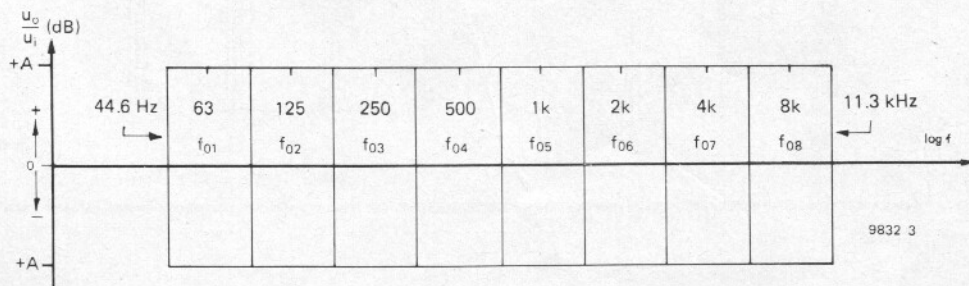

9832 3

passband, the response of the high-Q filter is several dB down on the ideal rectangular response, whereas that of the low-Q filter is not. On the other hand, the response of the high-Q filter is also a long way down where it overlaps into the passband of adjacent filters, whereas the response of the low-Q filter is only a few dB down, and will thus interact more with adjacent filters.

This is illustrated in figures 6 and 7, which respectively show two adjacent high-Q and two adjacent low-Q filters with various combinations of boost and cut. The individual responses of the two filters at full boost and full cut are shown, together with the combined response of the filters for all possible combinations of boost and cut, as follows:

Curve Number	Description
(1)	filter f_{01} , full boost
(2)	filter f_{02} , full boost
(3)	filter f_{01} , full cut
(4)	filter f_{02} , full cut
(5)	combined response, full boost
(6)	combined response, full cut
(7)	combined response, f_{01} boost, f_{02} cut
(8)	combined response, f_{01} cut, f_{02} boost.

The question arises as to which type of filter response should be chosen for the equaliser, low-Q, high-Q, or a compromise between the two? In practice it appears that an equaliser built using lower Q filters is judged to be more 'musical' by a majority of listeners.

Filter principles

Having decided on the type of response required from the filter, the next step is to decide how to achieve it. Figure 8a shows the basic circuit of one filter section. L and C form a series resonant

4

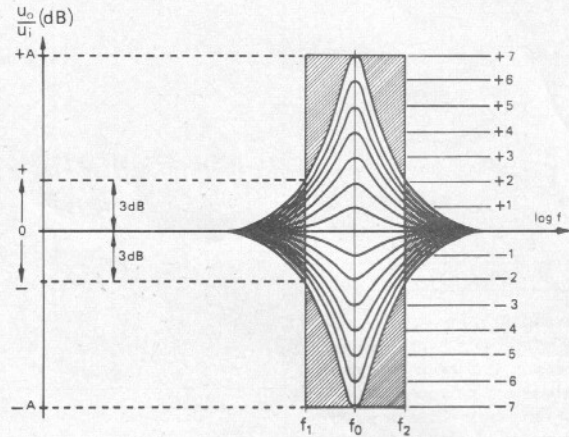

9832 4

5

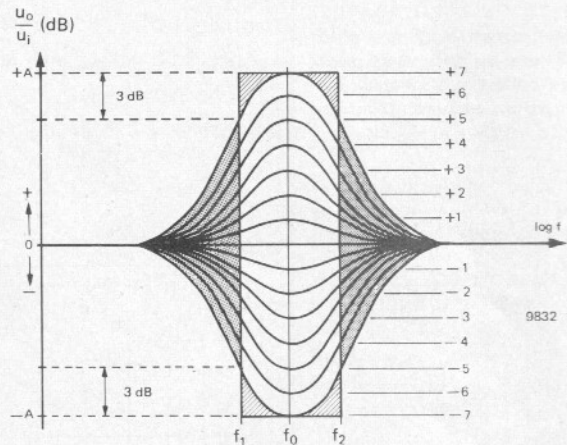

9832 5

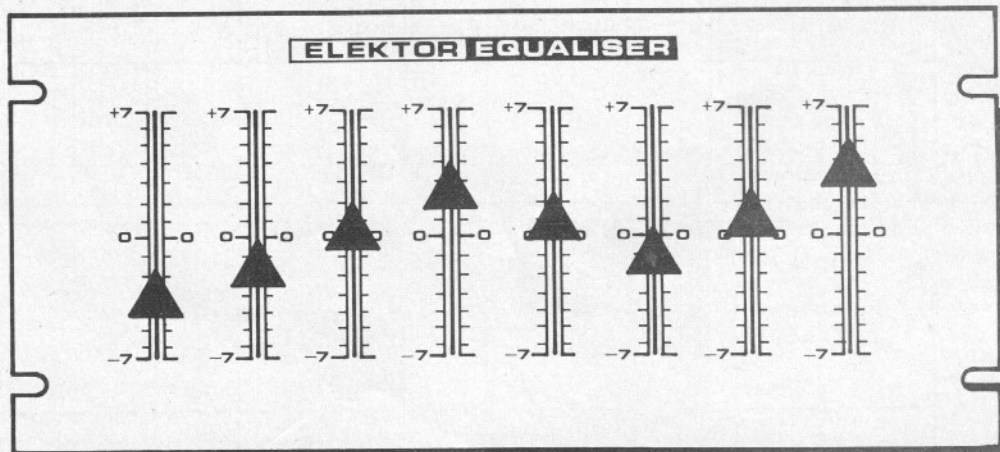

6

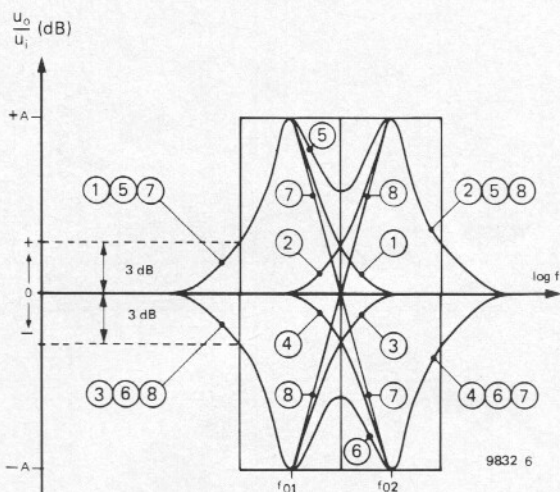

7

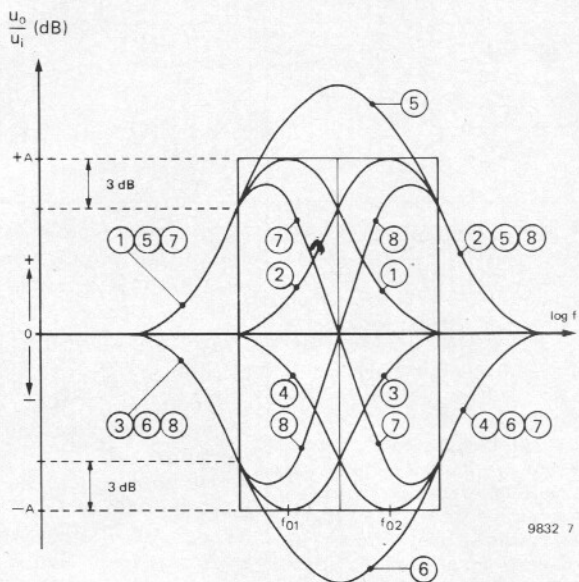

Figures 4 and 5. Since the ideal rectangular passband is impossible to realise, an approximation must be made using resonant circuits. These can either be high-Q, as in figure 4, or low-Q, as in figure 5.

Figures 6 and 7. Showing how adjacent filters interact. The high-Q filters (figure 6) have a much smaller 3 dB bandwidth and so interact less with the passbands of adjacent filters than do the low-Q filters (figure 7). Although it would thus appear that high-Q filters give better control with less interaction, low-Q filters are preferred from a musical point of view.

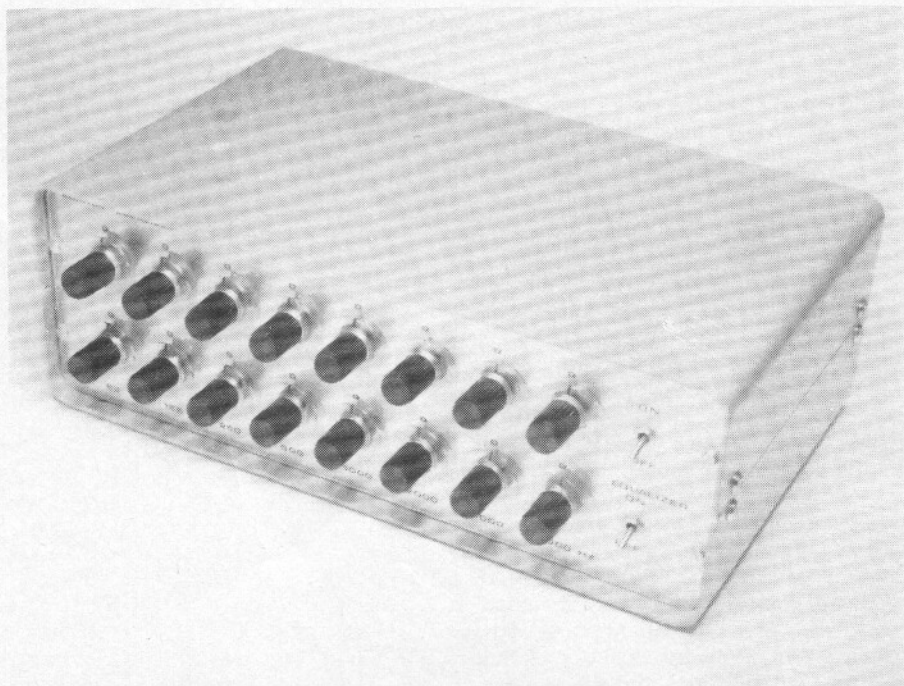

circuit. With the slider of R1 in the extreme left-hand position the op-amp functions as a voltage follower. Assuming the op-amp has sufficient open-loop gain the effect of R1 between the two inputs is negligible since very little voltage appears across it. The input resistor R and the resonant circuit form a bandstop filter. Within its passband the impedance of the resonant circuit is low, so the signal appearing at the non-inverting input of the op-amp, and hence at the output, will be severely attenuated.

With the slider of R1 in the extreme right hand position the op-amp functions as a non-inverting amplifier with a negative feedback network comprising feedback resistor R and the resonant circuit. The impedance of the series resonant circuit within its passband is low, so the gain of the amplifier is high and the signal is boosted. Outside the passband the impedance of the LC circuit is high, so whatever the setting of R1 the op-amp simply functions as a voltage follower and the signal is neither amplified nor attenuated.

With R1 in its mid-position the attenuation introduced by the bandstop filter action is exactly cancelled at all frequencies by the bandpass filter action, since the resonant circuit has an equal effect on both the signal path and the feedback path. The gain with R1 in the mid-position is thus 0 dB at all frequencies.

Having explained the basic principle of the filter the filter parameters may now be calculated. Potentiometer R1 and the series resonant circuit may be represented by a star network of three impedances Z_1 to Z_3 (figure 8b). To simplify the analysis the input and output circuits can be separated by transforming this circuit into its equivalent delta circuit as shown in figure 8c. This allows the following equations to be derived:

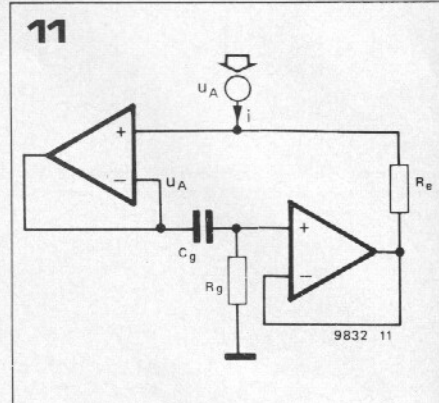
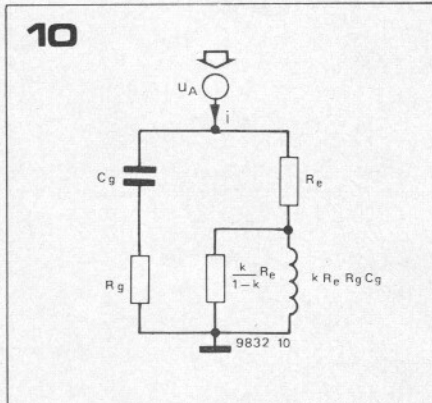
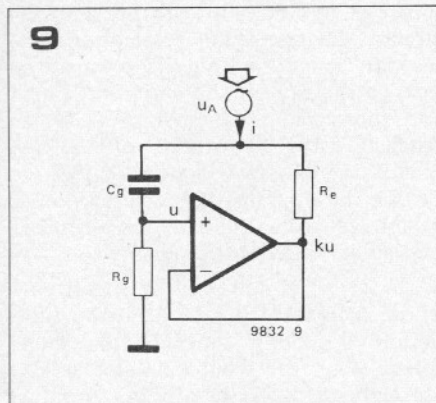
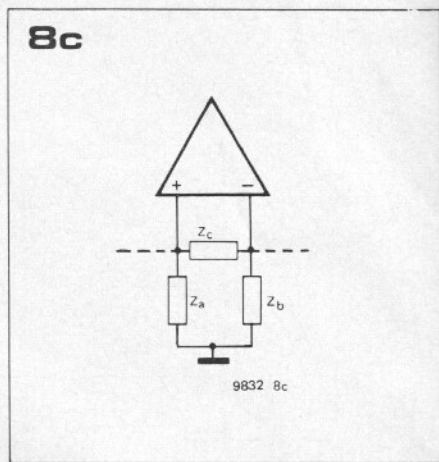
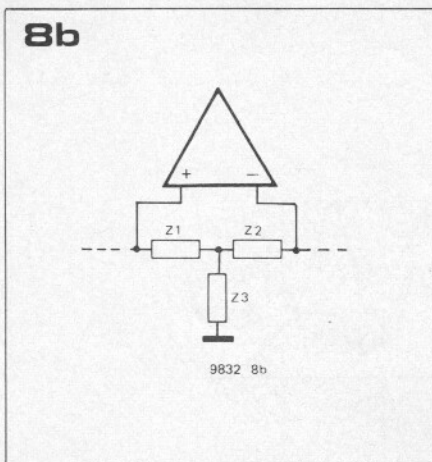
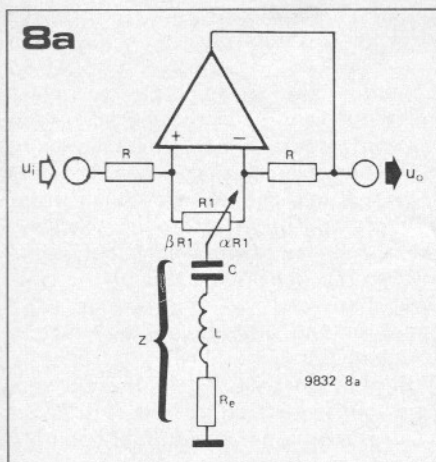

Figure 8a. The basic filter section of the equaliser, which will provide boost or cut depending on the setting of the pot. Performing a star-delta transformation on the circuit (figures 8b and 8c) makes analysis easier.

Figure 9. Basic circuit of a simulated inductor.

Figure 10. This circuit is equivalent to the circuit of figure 9. The synthesised inductor has a number of parasitic elements associated with it. However, if k is 1 the shunt resistance becomes infinite, Re can be used to determine the Q of the resonant circuit, and the effect of Cg can be made negligible by making Rg very large.

Figure 11. The effect of Cg and Rg can be eliminated entirely by using a buffer stage, but this is not really necessary in this application.

Figure 12. Complete circuit of the equaliser.

lated. For a maximum gain of 12 dB and -3 dB points as shown in figure 5 a Q of 1.5118 is necessary.

Inductors — wound or simulated?

It is worth considering at this point if the inductors used in the series resonant circuits should be conventional wound components.

A few quick calculations using the foregoing equations show that, for the low frequency filter sections inductances greater than 1 Henry are necessary if practicable values for R and Re are to be maintained. Such values can only be achieved conventionally by using large ferrite pot cores, which are bulky and expensive, to say nothing of the tedious process of winding the coils.

It is thus cheaper and more convenient to synthesise the required inductors electronically.

Figure 9 shows the circuit of an electronic inductor consisting of a voltage follower, two resistors and a capacitor. Figure 10 shows the equivalent circuit of this arrangement, with the synthesised inductance shown at the bottom right of the diagram. It can be seen that two parasitic networks appear in parallel with the inductor. The first of these is a resistor $\frac{k}{1-k} Re$, where k is the gain

of the op-amp. If k is made equal to 1 (which it is, since the op-amp is connected as a voltage follower) then the value of this resistor becomes infinite, and it cannot affect the inductor.

The second parasitic network consists of Re, Rg and Cg, and the effect of this can be reduced by making Rg large

$$\left(\frac{u_o}{u_i}\right)^2 = \frac{(1-x^2)^2 + \frac{K_1^2 x^2}{Q^2}}{(1-x^2)^2 + \frac{K_2^2 x^2}{Q^2}}$$

with $x = \frac{f}{f_0}$,

$$Q = \frac{1}{R_e} \sqrt{\frac{L}{C}}$$

$$K_1 = \frac{\alpha\beta R_1 + R_e + \beta R}{R_e}$$

$$\text{and } K_2 = \frac{\alpha\beta R_1 + R_e + \alpha R}{R_e}$$

where alpha and beta are functions of the slider position of R1 as shown in figure 8a;

$$\alpha = 1 - \beta.$$

The gain at the centre frequency (f = f0, x = 1) is K1/K2 which is dependent on the slider position of R1. The gain at f0 may be varied between

$$\frac{R + R_e}{R_e} \text{ and } \frac{R_e}{R + R_e},$$

i.e. between plus and minus A dB in figures 4 and 5. Once suitable values for A and the -3 dB points of the filter response have been chosen the required Q can be derived. For the practical circuit maximum boost and cut of 12 dB were chosen, and the -3 dB points were made to coincide with the 'ideal' band edges, as shown in figure 5. Having decided this the relative values of R and Re can be determined and the Q calcu-

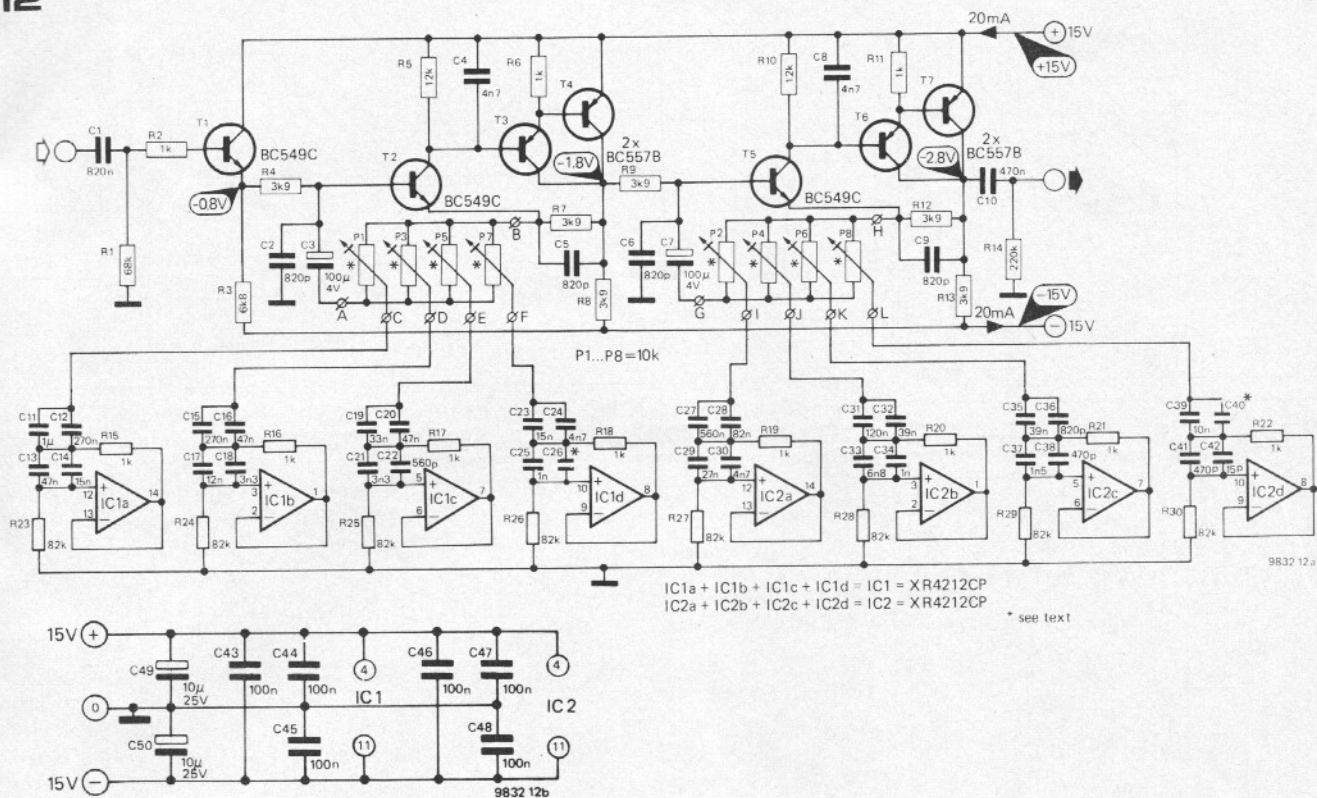

compared to R_e . The circuit then effectively becomes an inductor in series with a resistor R_e , which determines the Q when the inductor is connected into a series resonant circuit. It would be possible to eliminate the shunting effect of R_g and C_g entirely, by interposing a buffer, as shown in figure 11, but for the purposes of the equaliser this is unnecessary.

Performance of synthesised inductors

Conventional inductors produce negligible noise, and the distortion that they introduce is due mainly to saturation of the core material, which is negligible at moderate signal levels. Electronic inductors, on the other hand, are subject to certain limitations. Noise and distortion are introduced by the operational amplifier, and the voltage that can appear across the inductor is limited by the clipping level of the op-amp. Harmonic distortion can be reduced by ensuring that the voltage follower has good linearity, i.e. the gain remains constant at unity for all output levels. This means choosing an op-amp with a low output resistance, which is further reduced by the 100% negative feedback that is applied. As most op-amps operate with a class A-B output stage, crossover distortion can be a problem, so it is essential to operate the op-amp into a fairly high impedance load so that it stays in class A.

At resonance the voltages across the capacitor and across the (synthesised) inductor in the resonant circuit are in antiphase and are both equal to Q times

the voltage applied across the circuit, so it is essential that these voltages do not exceed the output range of the op-amp. It is thus necessary to compromise between operating at high signal levels to obtain a good signal-to-noise ratio, and operating at low signal levels to avoid clipping. Fortunately, the Q of the circuits used in the equaliser is low, so this is not too much of a problem. With the foregoing criteria in mind the inductance values and series capacitors of the resonant circuits can be calculated using the following equations:

$$f_0^2 = \frac{1}{4\pi^2 LC} ; Q^2 = \frac{L}{R_e C} ;$$

$$L = R_e R_g C_g (k = 1)$$

from which follow:

$$C = \frac{1}{2\pi f_0 Q R_e} ; C_g = \frac{Q}{2\pi f_0 R_g}$$

In the circuit described here we will use: $R_g = 82 \text{ k}$; $R_e = 1 \text{ k}$; $Q = 2$.

- Furthermore,
- $f_{01} = 63 \text{ Hz}$
- $f_{02} = 125 \text{ Hz}$
- $f_{03} = 250 \text{ Hz}$
- $f_{04} = 500 \text{ Hz}$
- $f_{05} = 1 \text{ kHz}$
- $f_{06} = 2 \text{ kHz}$
- $f_{07} = 4 \text{ kHz}$
- $f_{08} = 8 \text{ kHz}$

The correct values for C and C_g can now be calculated.

The circuit

Figure 12 shows the complete circuit of the equaliser. For acceptable audio performance the op-amp associated with

each filter section according to figure 8a must be a high-quality, low-distortion, low-noise amplifier, which means that discrete components are used in preference to monolithic ICs. It would be prohibitively expensive to provide a separate amplifier for each filter section (quite apart from the problem in maintaining a satisfactory S/N ratio), so several filter sections share one amplifier. This could cause problems due to interactions between individual filter characteristics if filter sections with adjacent passbands were connected to the same amplifier, so filter sections $f_{01}, f_{03}, f_{05}, f_{07}$ share the amplifier comprising T2, T3 and T4, while filter sections $f_{02}, f_{04}, f_{06}, f_{08}$ share the amplifier consisting of T5, T6 and T7. (Note that this interaction between individual filter characteristics is an entirely separate effect from the combined filter response of two overlapping passbands mentioned earlier.)

The input signal is fed first to an emitter-follower T1, then through the two cascaded filter amplifiers T2 to T4 and T5 to T7. The resemblance between these amplifiers and the theoretical op-amp shown in figure 8 may not be immediately apparent, but it becomes more so once it is realised that the base of T2 functions as the non-inverting input and its emitter as the inverting input. T3 and T4 are connected as a Darlington pair with a very high gain. The same comments apply to T5 ... T7. Each resonant circuit consists of a simulated inductor built around one-quarter of a quad op-amp, together with a series capacitor. For example the 63 Hz resonant circuit consists of a simulated

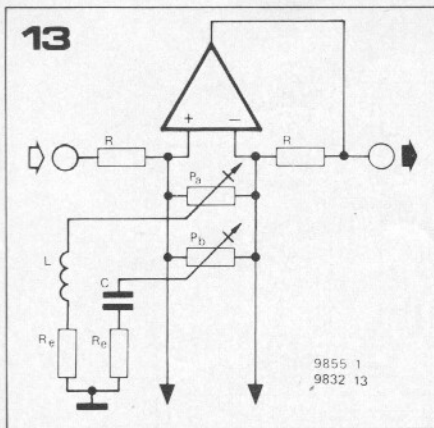

9855 1
9832 13

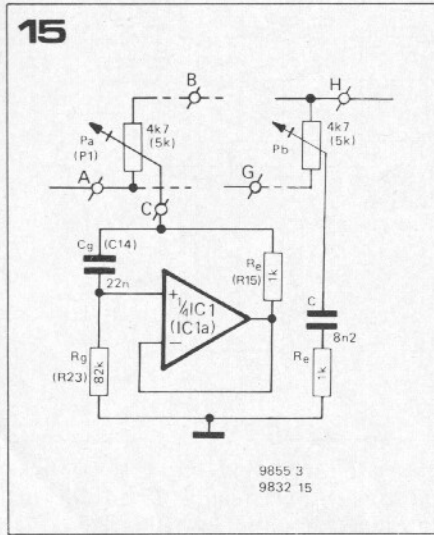

9855 3
9832 15

Figure 13. Modifications to the basic filter section of the equaliser, if 'Baxandall' type bass and treble controls are required.

Figure 14. Frequency response of the bass and treble controls.

Figure 15. Circuit modifications required for adding bass and treble controls. With the values shown, the turnover frequencies (f_2 and f_3 in figure 14) are 500 Hz and 4 kHz, respectively; the maximum cut or boost is 12 dB.

Figures 16 and 17. Printed circuit board and component layout for the equaliser (EPS 9832).

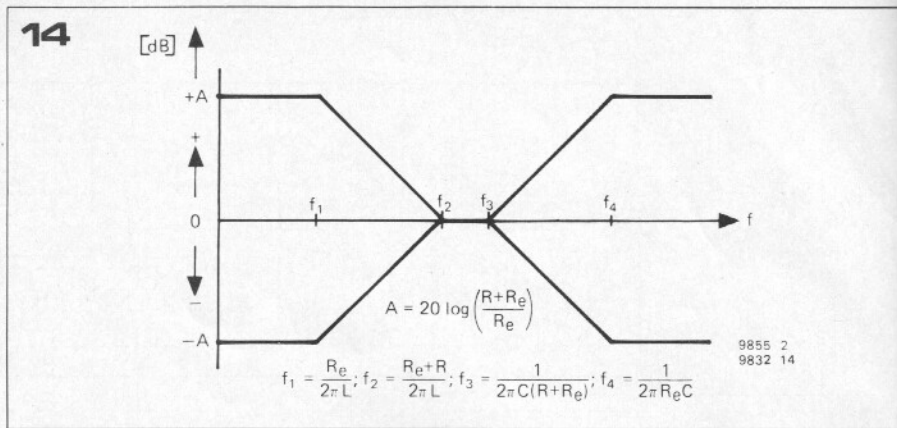
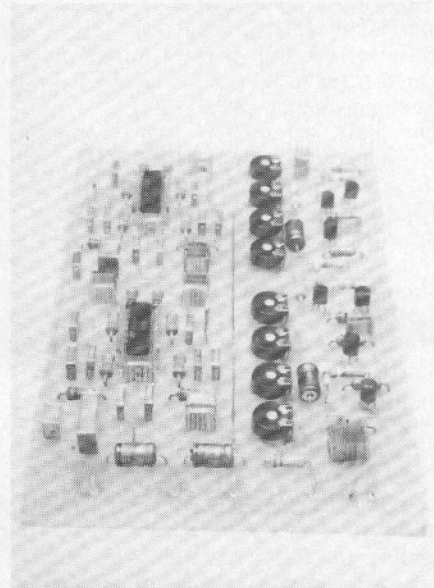

9855 2
9832 14

inductor comprising IC1a, R15 (= R_e), R23 (= R_g), C13 and C14 (= C_g), and a series capacitor C11/C12 (= C). In most cases the inductor capacitor and series capacitor are made up from two parallel capacitors to obtain the exact value, but this is not necessary in the case of C25/C26 and C39/C40, so C26 and C40 are omitted.

Adding tone controls

Although the Elektor equaliser is quite adequate as it stands for incorporation into an existing hi-fi set up (with bass and treble controls), some additional control is required at the top and bottom end of the audio spectrum for use in systems without existing tone controls. A simple modification allows a 'Baxandall' type of tone control to be added, which will give boost and cut at the very extremes of the audio spectrum. This facility can be extremely useful, for example to provide some bass lift to compensate for the lack of bass output from bookshelf speakers.

Figure 13 shows the modifications to the basic filter section of the equaliser. Comparing this with figure 8a it can be seen that the series-resonant circuit has been replaced by an LR circuit for the bass control and a CR circuit for the treble control. These circuits still give boost or cut depending on the position of P_a or P_b , but since a resonant circuit is not used a high and low filter response is obtained, rather than the band filter response obtained with the resonant circuit.

The frequency response of the bass and treble controls is shown in figure 14. The turnover frequencies f_1 to f_4 are determined by the values of L, C, R_e and R, in accordance with the equations shown in figure 14.

The practical circuit, shown in figure 15, is designed for turnover frequencies $f_2 = 500$ Hz and $f_3 = 4$ kHz, and a maximum boost and cut of 12 dB, which is the same as the rest of the equaliser circuit. The treble control is added simply by including an extra potentiometer, P_b , between points G and H on the equaliser board, together with resistor R_e and capacitor C. The bass control, however, requires a simulated inductor, and to obtain this it is necessary to omit the lowest equaliser control, P1, and to

convert the circuit around IC1a for use as the bass control inductor. In other words, P1 is now replaced by the 5 k bass control, C11 and C13 are omitted, C12 is replaced by a wire link and C14 becomes 22 n.

Construction

A printed circuit board and component layout for the equaliser are given in figures 16 and 17, and construction should present no problems. The equaliser can be built into its own case, or may be incorporated into other equipment such as an amplifier system. For stereo operation two printed circuit boards are, of course, required.

If the circuit is simply to be used as a room equaliser in one listening room then potentiometers P1 to P8 can be presets mounted direct on the printed circuit board, which are adjusted once and then left. If the circuit is to be used in place of a tone control system or to produce special effects then (screened!) connections must be brought out to potentiometers mounted on the front panel. The potentiometers may be either rotary or slider types, but we feel that the sliders often used in such equalisers give no real advantage over rotary types, since the 'graphic' response which they apparently display is a myth. Furthermore sliders are more expensive, and frequently less reliable than rotary types.

With all the potentiometers in their centre positions, the equaliser has a gain of unity, and so may be connected into any audio chain without affecting the overall gain. However for the best compromise between noise and overload margin ($v_{i, max} \approx 2$ V) it is best to connect the equaliser between the pre-amp and control/main amplifier where signal levels are of the order of a few hundred millivolts. The tape socket of an existing amplifier may be used for this purpose.



Parts list

Resistors:

R1 = 68 k
 R2,R6,R11,R15,R16,R17,
 R18,R19,R20,R21,R22 = 1 k
 R3 = 6k8
 R4,R7,R8,R9,R12,R13 = 3k9
 R5,R10 = 12 k
 R14 = 220 k
 R23,R24,R25,R26,
 R27,R28,R29,R30 = 82 k
 P1 ... P8 = (preset) potentiometer
 10 k lin (see text)

Capacitors:

C1 = 820 n
 C2,C5,C6,C9,C36 = 820 p
 C3,C7 = 100 μ /4 V
 C4,C8,C24,C30 = 4n7
 C10 = 470 n
 C11 = 1 μ
 C12,C15 = 270 n
 C13,C16,C20 = 47 n
 C14,C23 = 15 n
 C17 = 12 n
 C18,C21 = 3n3
 C19 = 33 n
 C22 = 560 p
 C25,C34 = 1 n

C26 is omitted

C27 = 560 n
 C28 = 82 n
 C29 = 27 n
 C31 = 120 n
 C32,C35 = 39 n
 C33 = 6n8
 C37 = 1n5
 C38,C41 = 470 p
 C39 = 10 n
 C40 is omitted
 C42 = 15 p
 C43,C44,C45,C46,
 C47, C48 = 100 n MKM
 C49,C50 = 10 μ /25 V

Semiconductors:

T1,T2,T5 = BC 549C, BC 109C
 or equivalent
 T3,T4,T6,T7 = BC 557B, BC 177B
 or equivalent
 IC1,IC2 = XR 421 2CP
 (Exar)

16

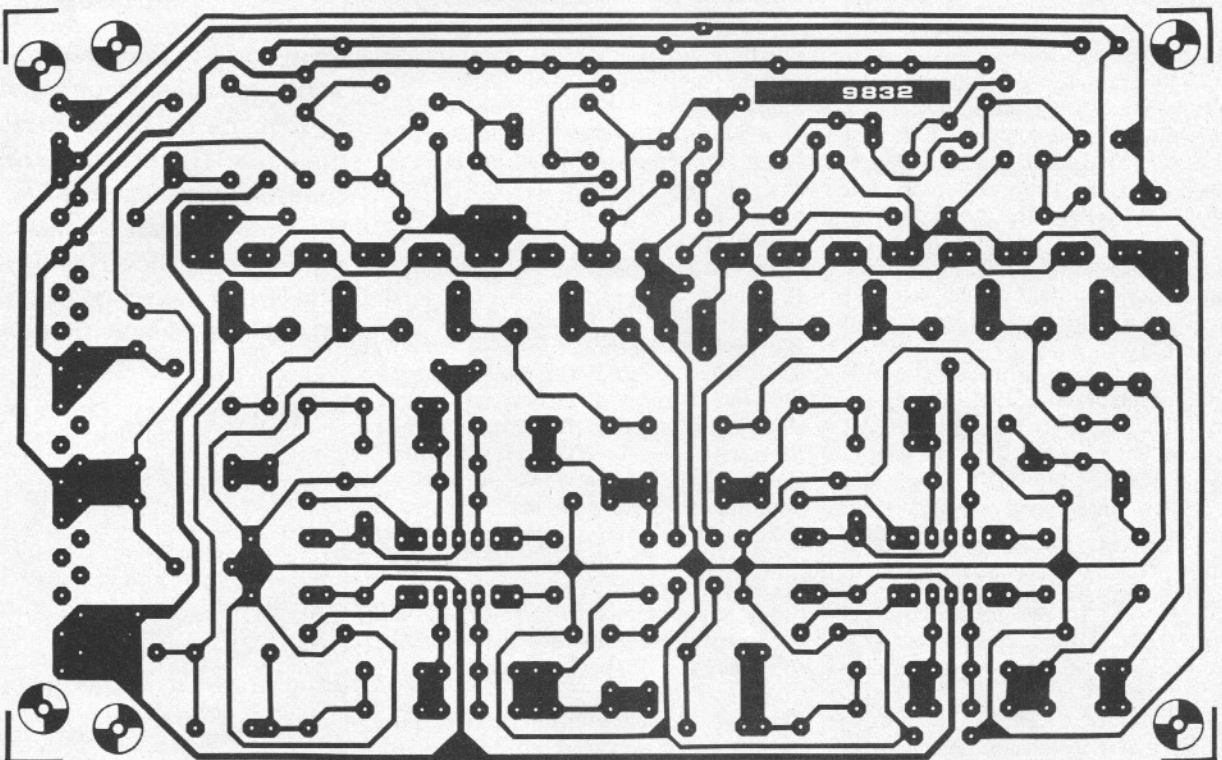

17

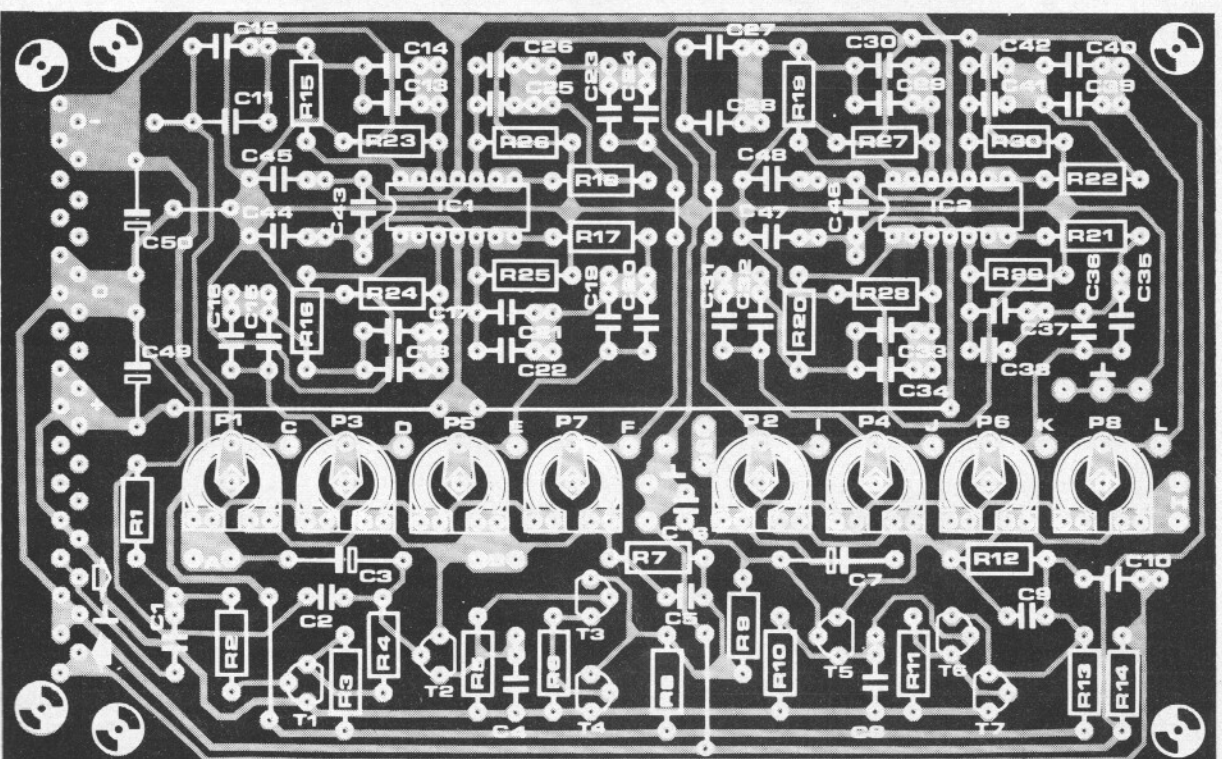

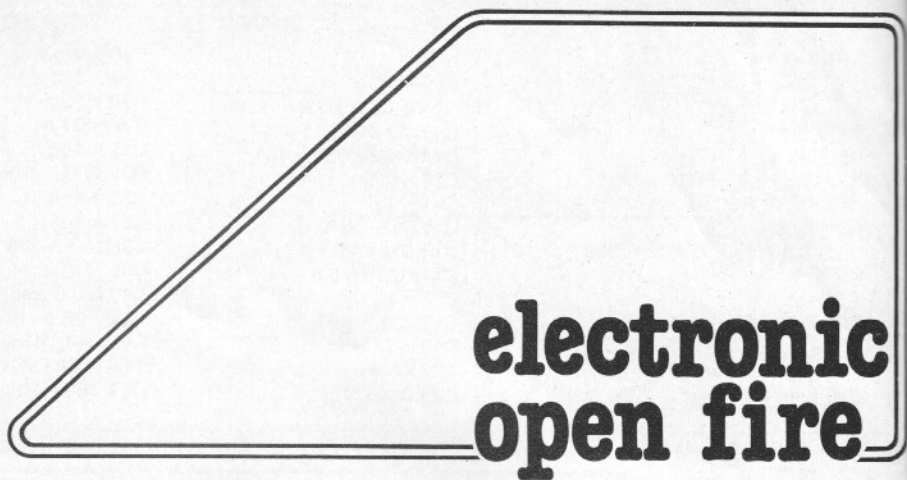
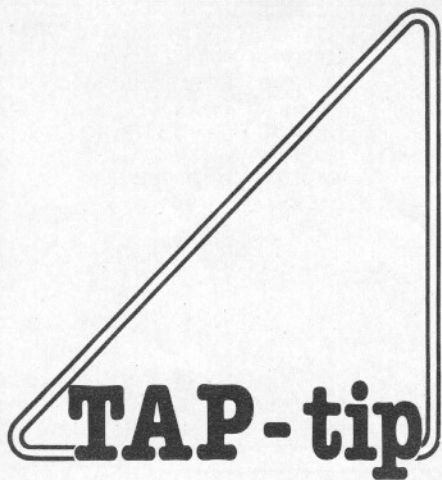

Many circuits for TAPs (Touch Activated Programme switches) have previously been published in Elektor. However, all of these required the use of two pairs of touch contacts, one to set the TAP to the 'on' position and one to reset it to the 'off' position. The novel feature of this circuit is that it requires only one touch contact. Touching the contact once sets the TAP; touching it a second time resets the TAP.

N1 and N2 form a flip-flop (bistable multivibrator). Assume that initially the output of N2 is low. The inputs of N1 are also pulled low via R2, so the output of N1 is high. The inputs of N2 are thus high, which satisfies the criterion for the output to be low, which was the original assumption. C1 is charged to logic high through R3 from the high output of N1. If the touch contacts are now bridged by a finger, the logic high on C1 will be applied to the inputs of N1 through R1 and the skin resistance. The output of N1 will go low, so the output of N2 will go high, holding the inputs of N1 high even if the finger is removed. The TAP is now set. Once the finger is removed, C1 will discharge through R3 into the low output of N1. If the touch contacts are subsequently bridged, the inputs of N1 will be pulled low by C1 (since it is now discharged). The output of N1 will thus go high and the output of N2 low, which will hold the inputs of N1 low even after the finger has been removed. The TAP is now reset to its original state. C1 will charge to logic high through R3 from the output of N1, ready for the contact to be touched again.

The only constraint on the operation of the circuit is that the interval between successive operations of the switch must be at least half a second to allow C1 time to charge and discharge. ◀

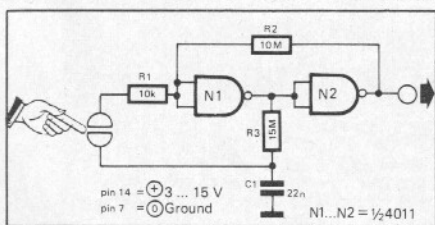

There is no doubt that most people find the sight of an open fire pleasing. There seems to be something soothing in watching the flames flicker and play about the coals. On the other hand, coal fires are difficult to light, slow in producing heat, and also extremely messy to clean out. For this reason many people prefer the convenience and speed of an electric fire, and reluctantly relinquish the pleasures of a hearth fire. Manufacturers of electric fires have realised this fact, and attempted to entice the consumer to buy electric by fitting the front of their fires with a coal- or log effect. Unfortunately, the lamps which are used to illuminate these fronts sometimes provide only a constant light, thereby considerably diminishing the realism of the effect. However, using only a handful of components from the junk-box, it is possible to construct a small circuit to restore the 'flicker' in your fire.

The way the circuit functions is quite simple. When power is applied capacitor C1 is charged via the lamp, resistor R2 and diode D1. After several half cycles of the mains supply, the voltage across this capacitor exceeds the trigger voltage of diac Di1. This diac in turn triggers thyristor Th1, with the result that capacitor C2 charges up rapidly through this thyristor and D1. However, when the mains voltage next crosses zero, this thyristor turns off. Capacitor C3, which is part of the trigger circuit of Tri1, is now charged rapidly by capacitor C2 via resistor R3. This 'DC bias' on C3 decreases as capacitor C2 discharges. This in turn results in a gradual change in the triggering angle of the triac, causing the lamp La to flicker. Once C1 has again reached the trigger voltage of the diac, the entire cycle repeats itself.

As far as component values are concerned, care should be taken to ensure that the maximum current taken by the triac is at least twice the maximum current drawn by the lamp La. For a normal sized fire a 4 A type should prove sufficient. The triac must also be able to withstand the peak mains voltage i.e. approx. 400 V. A 400 V (1 A) thyristor should also prove suitable. D1

electronic open fire

Many electric fires are equipped with a special coal- or log-effect to simulate the appearance of an open fire. This effect is sometimes spoilt, however, by the fact that the lamp provides a constant rather than a flickering light. The circuit described here is intended to remedy that defect.

S. Kaul

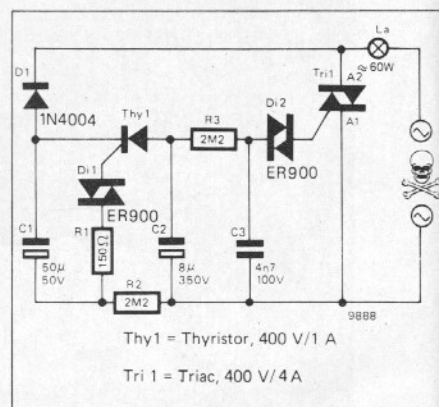

may be any commonly available 600 V rectifier diode. During construction it should be remembered that the full mains voltage may appear across any point in the circuit. For this reason it should be well insulated. ◀

peak programme meter

A meter for measuring audio signal levels must satisfy several criteria. Firstly, the A.C. signal must be rectified before it can be displayed on a moving coil- or other D.C. meter. Secondly, since large signal peaks can overload equipment, the meter must be capable of rapid response to signal peaks. In addition, since signal peaks may last too short a time for the meter to be read, the meter must store peaks long enough for the user to read the meter. Finally, since the human ear has a logarithmic response, the meter response should also be logarithmic.

Block diagram

Figure 1 shows a block diagram of the peak programme meter drive circuit. It consists of two stages, a peak rectifier (A) and a logarithmic amplifier (B), with a sensitivity control, P1, between them.

The rectifier charges a capacitor to the peak value of the A.C. input signal and the logarithmic amplifier gives an output voltage proportional to the logarithm of the D.C. voltage on the capacitor. This output can be used to drive a moving coil or other meter, which can be scaled linearly in dB.

Complete circuit

The left channel of the PPM drive circuit is shown in figure 2. The peak rectifier, built around A1, rectifies negative half-cycles of the input waveform. The signal is applied, via C1 and R2, to the inverting input of A1. The right channel circuit is identical, but components are identified by an apostrophe (').

Under quiescent conditions A1 is operating open-loop, since D2 is not forward biased and there is thus no negative feedback via R4. When the input voltage goes negative the output of A1 swings rapidly positive until limiting occurs. D2 conducts and C2 charges rapidly through D2 and R5. Equilibrium is reached when the positive voltage on C2 equals the negative input voltage, when feedback via R4 will have reduced the voltage at the inverting input of A1 to almost zero. In the case of an A.C. input signal, C2 will, of

course, charge to a positive voltage equal to the peak negative input voltage. On positive half-cycles of the input signal, the output of A1 swings negative and D2 is reverse-biased. Since there is no negative feedback to the inverting input, D1 is included to limit the maximum positive excursion at this point to 0.6 V, as otherwise the common-mode range of A1 could be exceeded. Since C2 cannot discharge through D2, its only discharge paths are through P1 and R4, which means that the discharge time constant of the peak rectifier is just less than one second.

Using only one IC and a few discrete components it is possible to construct a peak programme meter drive circuit that will provide a logarithmically-scaled indication of the peak A.C. input level. The circuit can be used with either LED or moving coil voltmeters to make a compact, two-channel PPM.

Logarithmic amplifier

Extremely accurate logarithmic amplifiers can be made by exploiting the exponential collector versus base-emitter voltage characteristic of a transistor. However, this type of logarithmic amplifier is unnecessarily complex for use in a simple peak meter circuit, so the approach adopted is to make a 'piecewise-linear' approximation to a logarithmic curve.

The principal characteristic of a logarithmic amplifier is that the output voltage increases arithmetically in response to geometric increases in input voltage. To take a simple example, if a 10 mV input gives an output of 1 V, then ten times this (i.e. 100 mV) would give an output of 2 V and 1 V would give an output of 3 V, etc. An approximation to this type of curve can be achieved by progressively reducing the gain of an op-amp as the input voltage to the amplifier is increased.

In figure 2, A2 has a gain of about 150 at low signal levels. However, once the output level reaches around 4.6 V, D3 conducts, increasing the amount of negative feedback and reducing the gain. At an output voltage of approximately 5.6 V, D4 conducts, and at an output voltage of about 8 V, D5 conducts. The gain of A2 is thus progressively reduced as the input signal increases. Of course, the diodes do not conduct abruptly at a particular voltage — their dynamic resistance reduces gradually as the voltage increases. This means that the piecewise curve does not have a series of sharp break points, but

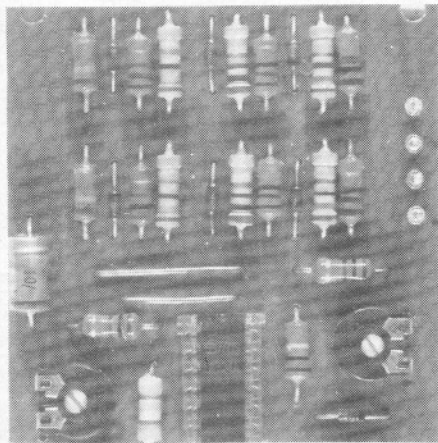

1

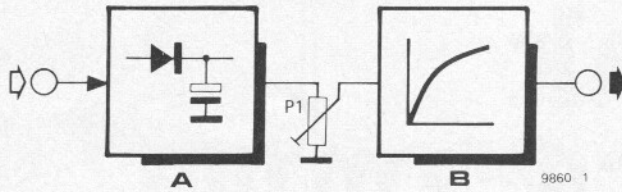
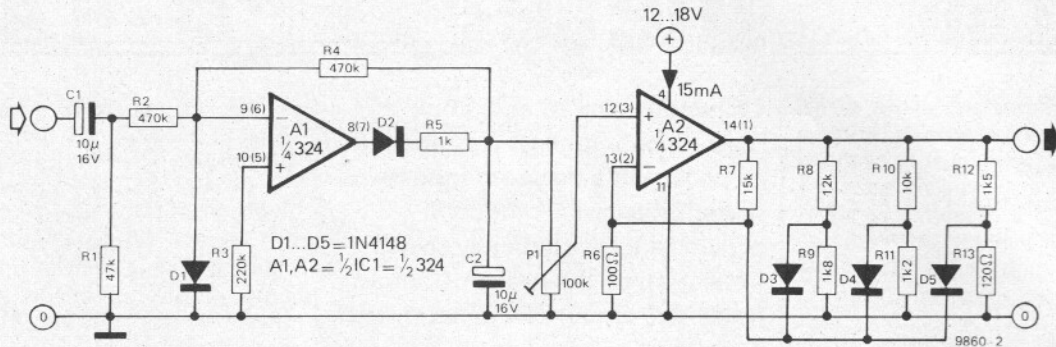

Table 1. Principal specifications of the PPM drive circuit.

Maximum sensitivity:	nominal output
	10 V DC for
	150 mV RMS
	input.
Maximum input level:	5 V RMS.
Input impedance:	≈ 43 k
Supply voltage:	12...18 V (18 V
	absolute maxi-
	imum!)
Current consumption:	30 mA (15 mA
	per channel)

2



is relatively smooth, as shown in figure 3.

Although this method of producing an approximation to a logarithmic curve is simple and cheap, it does have one or two minor drawbacks. Firstly, due to tolerances in the resistors and diodes used in the circuit, there may be deviations from a true logarithmic response. This means that the two channels of the meter may not give the same reading when fed with the same input voltage. However, potentiometers P1 and P1' allow accurate calibration of the full-scale reading of both channels, so any mismatch will only be apparent at small input levels, where it is not so important.

The second drawback of this system is that the meter only has a range of just over 20 dB (a voltage ratio of 10 to 1). However, this is comparable with the 23 dB calibrated range of a VU meter, or the 28 dB calibrated range of a BBC PPM, and since the circuit is intended principally for indication of peak signal and overload levels, this relatively small range is not a great disadvantage. If the PPM drive circuit is used with a UAA 180 LED voltmeter, then each of the 12 LEDs represents a step of approximately 2 dB, as shown in figure 4.

Construction

The use of a 324 quad op-amp allows a two-channel version of the meter drive circuit to be accommodated on a single, compact printed circuit board, the component layout and track pattern for which are given in figures 5 and 6.

The p.c. board is the same size as that for the two-channel UAA 180 LED voltmeter described elsewhere in this issue, so the two boards may be stacked

Figure 1. The peak meter drive circuit consists of a rectifier, peak storage capacitor, sensitivity control and logarithmic amplifier. The circuit may be used to drive either moving coil or LED voltmeters.

Figure 2. Complete circuit of the PPM meter drive. An active rectifier built around A1 rectifies and inverts negative half cycles of the input waveform and charges C2 to their peak value. The feedback arrangement around A2 progressively reduces the gain as the input signal increases to provide a 'piecewise linear' approximation to a logarithmic curve.

Figure 3. Transfer characteristic of the logarithmic amplifier. Since the diodes turn on gradually the transition from one portion of the curve to another is smooth, without any sharp break points.

Figure 4. If the UAA 180 LED voltmeter is used with the PPM drive circuit, each of the 12 LEDs can represent a 2 dB step.

Figure 5 and 6. Printed circuit board and component layout for the PPM drive circuit. This is the same size as the LED voltmeter board so that the two may be stacked together to form a compact unit. (EPS 9860).

together to form a compact, two-channel PPM.

Alternatively, the meter drive circuit may be used with a pair of moving-coil meters such as 100 μ A meters with 100 k series resistors or 1 mA meters with 10 k series resistors. However, if moving-coil meters are used it is important to remember that the response time of the meter will be affected by the mechanical inertia of the meter movement, and overshoot may also occur if the movement is poorly damped.

Testing and calibration

The PPM requires a power supply of between 12 volts and 18 volts maximum. If moving-coil meters are used then the supply should be capable of providing about 30 mA, but if the LED voltmeter board is used a 100 mA supply is necessary.

Before the outputs of the meter drive circuit are connected to the inputs of the LED voltmeter, the latter must be calibrated to read 10 V full-scale. This is achieved by connecting the L and R inputs of the LED voltmeter to a variable bench power supply, together with a multimeter set to the 10 V range (or nearest suitable range). The power supply output is adjusted until the multimeter reads 10 V, and P3 and P3' on the LED voltmeter board are adjusted until every LED in each column is lit. If moving-coil meters are used with the specified resistor values this procedure is unnecessary.

The outputs of the meter drive board may now be connected to the inputs of the voltmeter board. P1 and P1' on the meter drive board can be used to set the desired sensitivity of each channel. This will obviously depend on the

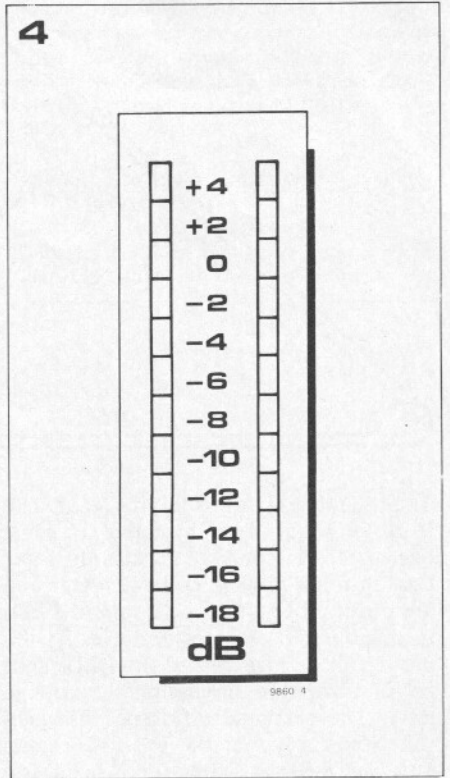
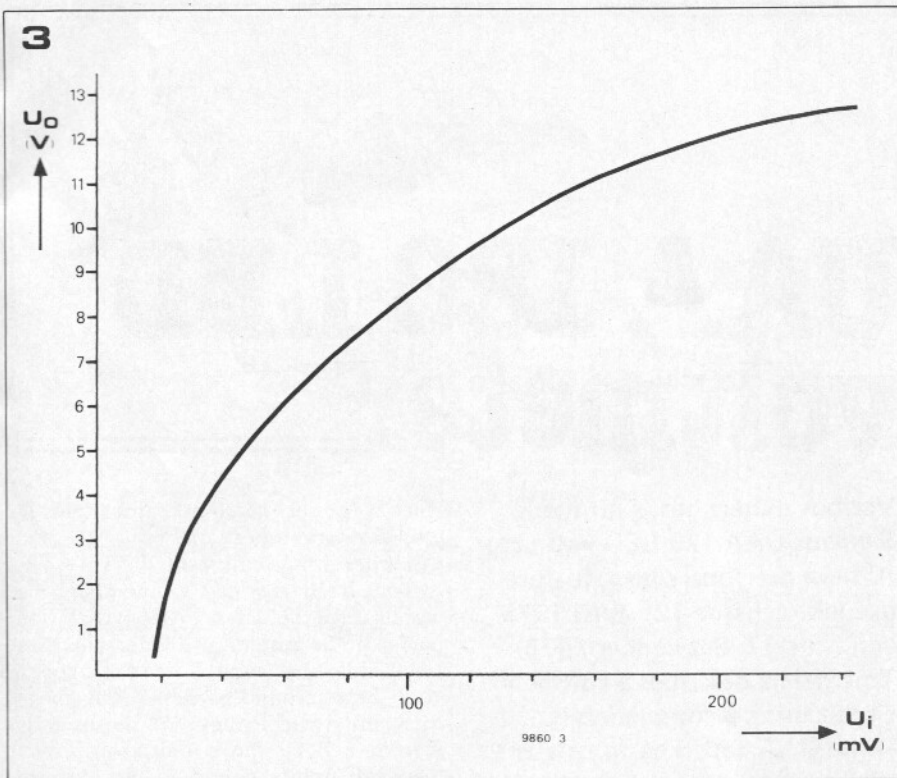

intended application of the meter. The meter scale can be calibrated linearly from -18 to +4 dB, the portion of the scale above 0 dB being marked in red to indicate overload. If the LED voltmeter is used then green LEDs can be used up to -2 dB and red LEDs from 0 to +4 dB so that an overload condition can easily be seen. As it stands, the meter drive circuit will accept a maximum input of 5 V RMS. If larger voltages are to be measured (such as amplifier outputs) then a resistor must be included in series with each input to form a potential divider with R1. For example, a 180 k resistor would allow input voltages up to 25 V RMS to be measured. **M**

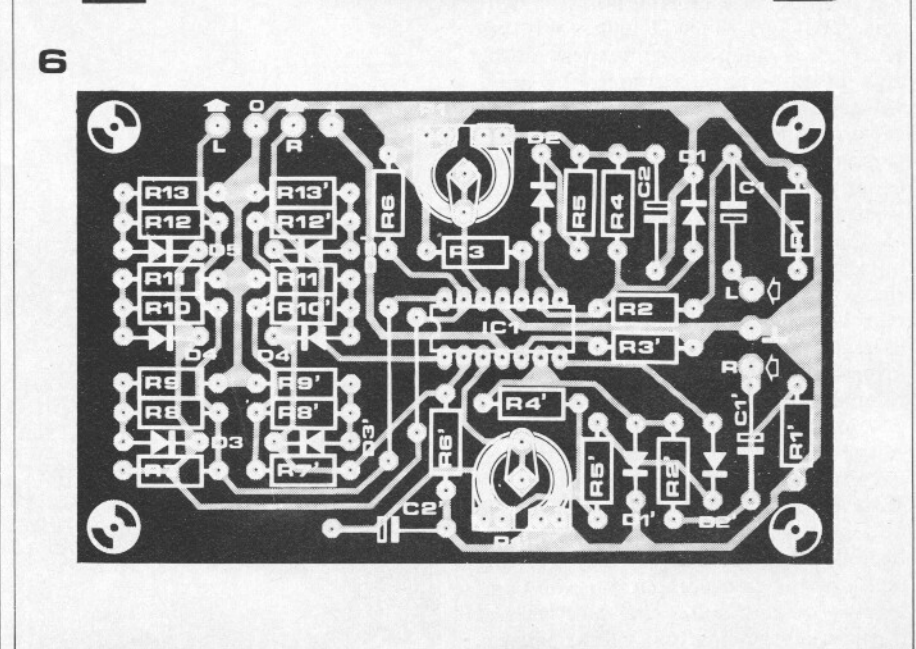
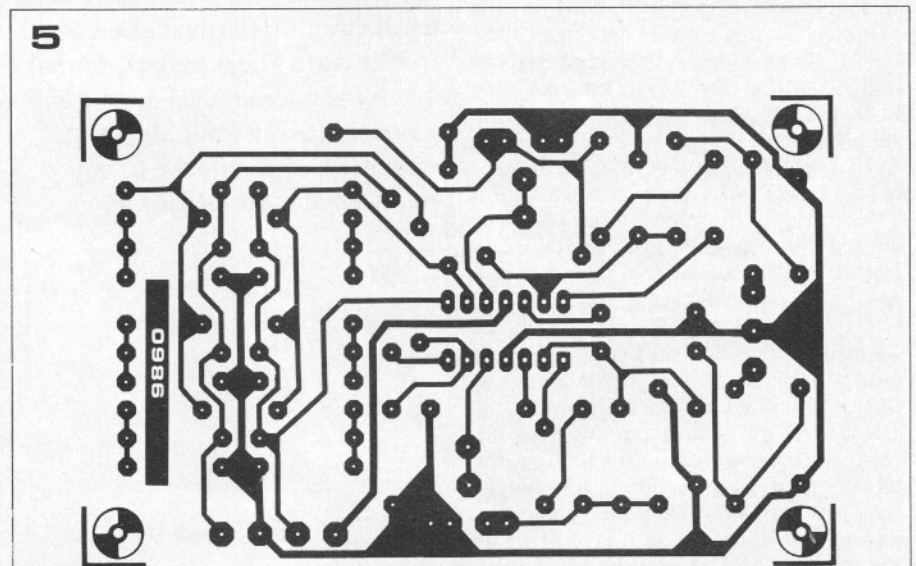

**Parts list for left channel:
duplicate for right channel.**

Resistors:

- R1 = 47 k
- R2, R4 = 470 k
- R3 = 220 k
- R5 = 1 k
- R6 = 100 Ω
- R7 = 15 k
- R8 = 12 k
- R9 = 1k8
- R10 = 10 k
- R11 = 1k2
- R12 = 1k5
- R13 = 120 Ω
- P1 = 100 k preset

Capacitors:

- C1, C2 = 10 μ/16 V

Semiconductors:

- D1 to D5 = 1N4148, 1N914
- A1, A2 = 1/2 IC1 = 1/2 324

UAA 180 LED voltmeter

The Siemens UAA 170 and UAA 180 ICs, which have been available for some time, are electronic replacements for a conventional moving coil voltmeter and are designed to drive a column of LEDs in response to an input voltage. As the input voltage is increased the LEDs light up in turn, thus indicating the voltage level. The principal difference between the two ICs is that the UAA 170 lights only one LED at a time (i.e. whenever a LED lights the previous LED in the column extinguishes) whereas the UAA 180 provides a thermometer-type indication (i.e. the LEDs, once lit, stay lit so that at full scale the whole column is illuminated).

Both these ICs may be used to replace conventional voltmeters in applications not requiring fine resolution, which is limited to one-sixteenth of the scale length in the case of the UAA 170 and one-twelfth of the scale length in the case of the UAA 180. However the resolution can be improved by using more than one IC and LED array, as will be described in detail later.

The UAA 180 is most useful in applications requiring rapid reading of the meter, such as in audio level meters, since it is much easier to judge the length of a column than it is to estimate the position of a moving point of light. The UAA 170, since it lights only one LED at a time, consumes less power and is thus more suitable for applications where a thermometer-type indication is not necessary, for example, in tuning scales for varicap FM tuners and other general voltmeter applications.

Figure 1 illustrates the basic principle of the UAA 180 LED voltmeter IC. A number of analogue comparators have their non-inverting inputs joined together and connected to the input voltage that is to be measured. The inverting inputs are connected to reference voltages derived from a potential divider chain between points A and B. A is assumed to be at a higher potential than B.

With no input voltage, all the LEDs will be extinguished. When the input voltage exceeds the voltage on the inverting input of the first comparator, the comparator output will swing positive and D₁ will light. When the voltage exceeds

Various meters based on the Siemens UAA 170 LED voltmeter IC have previously been featured in Elektor (issue 12, April 1976 and issue 17, September 1976). This article describes a voltmeter circuit using a companion IC — the UAA 180. The voltmeter can be combined with the PPM drive circuit described elsewhere in this issue ('peakmeter') to make a compact audio level meter, and a novel board layout allows extension of the meter to any required number of LEDs.

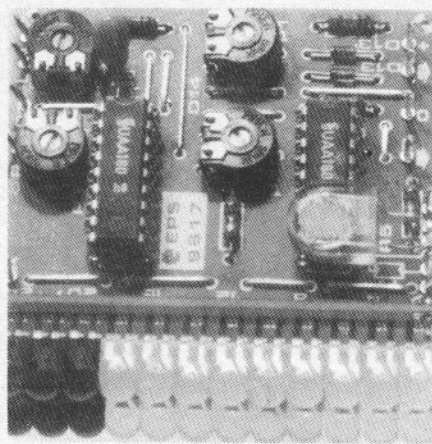

that at the second comparator input, D₂ will also light and so on.

An interesting feature of the UAA 180, which readers may remember also applies to the UAA 170, is that both ends of the potential divider chain are accessible, and point B need not necessarily be at ground potential. This means that the voltage range of the meter is determined by the potential difference between points A and B, but the zero point of the meter may be independently adjusted by varying the voltage at point B.

This facility makes it extremely simple to build a 'suppressed-zero' voltmeter, which can be useful in applications where the voltage to be measured never drops below a certain value, and where the lower part of a normal (zero = 0 volts) meter would be wasted. For example, in equipment using a 9 V dry battery the minimum usable battery voltage might be, say, 8 V. Battery voltages below this are of no interest since the battery is then defunct, so the voltmeter need only read over the range of, say, 8 V to 10 V. Using the UAA 180 to measure only over this 2 volt range obviously gives much better resolution than using it as a 0 to 10 V meter.

Another use of the suppressed zero facility is to allow extension of the display to 24 LEDs, or even more. Take, for example, a voltmeter that was to read from zero to 2.4 V in 0.1 V steps. This would require two UAA 180s. The inputs would be joined so that both were fed with the same voltage, but the first IC would have point B connected to ground and point A to 1.2 V, whilst the second IC would have point B at 1.2 V and point A at 2.4 V. The first IC would display voltages from zero to 1.2 V, above which the second IC would take over.

There are other similarities, and also other differences, between the UAA 170 and UAA 180. Both the UAA 170 and UAA 180 have provision for connecting a light-dependent resistor to vary the display brightness to suit ambient illumination. One feature possessed by the UAA 170 however, which the UAA 180 lacks, is a reference voltage output. An external reference voltage

1

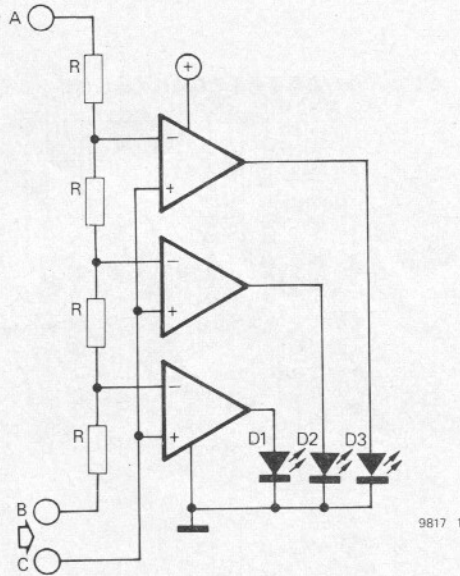

Figure 1. Basic principle of the UAA 180. A series of voltage comparators measure the input voltage against reference voltages derived from a potential divider chain. When a reference voltage is exceeded the appropriate LED lights.

Figure 2. Complete circuit of a two-channel LED voltmeter.

Table 1. Absolute maximum ratings of the UAA 180, which must not be exceeded.

Table 1

Absolute maximum ratings of the UAA 180. All voltages referenced to pin 1.

Supply voltage at pin 18:	+18 V
Input voltage at pin 17, reference voltages at pins 3 and 16:	+6 V
Operating temperature range:	-25 to +80°C.

2

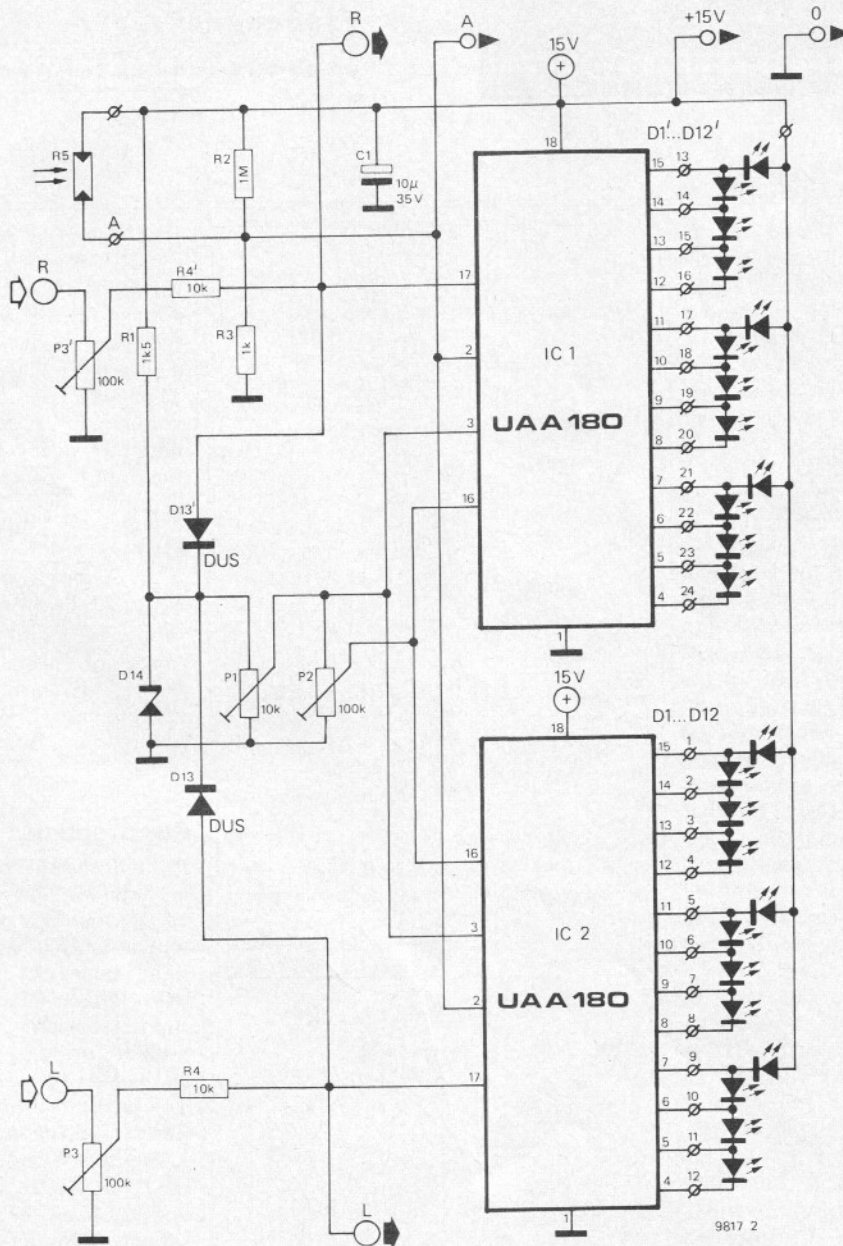

9817 2

3

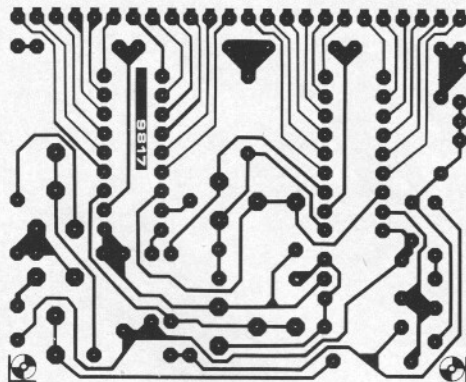
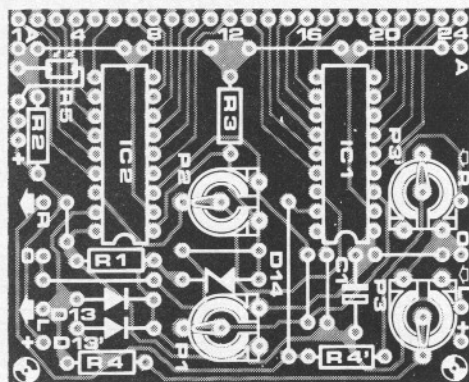

4

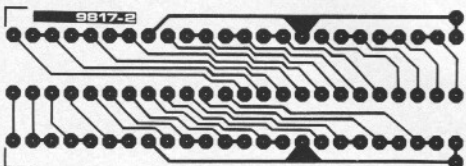
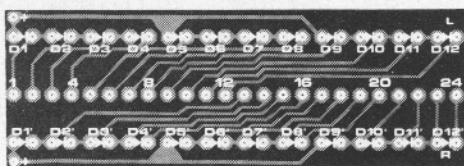

must be provided for the UAA 180. Another small disadvantage of the UAA 180 is that it is housed in an 18-pin DIL package. This can be a problem if IC sockets are to be used, since 18-pin sockets are not exactly common! However, a solution exists in the form of Soldercon socket strips, which can be cut to any desired length.

Complete voltmeter circuit

Figure 2 shows a complete circuit for a two-channel voltmeter using UAA 180 ICs. This is especially intended as a stereo audio level meter for use with the PPM drive circuit described elsewhere in this issue. However, for single-channel applications IC1 and all components marked with an apostrophe (') may be omitted. The most striking difference between this circuit and the basic circuit given in figure 1 is that the LEDs are arranged in three series-connected groups of four. This means that when all four LEDs in a group are illuminated, the same current flows through all four from the supply, thus reducing the current consumption by a factor four compared to the arrangement of figure 1, where there is an independent connection to each LED.

The high and low reference voltages for both channels are derived from a zener diode, D14. The high reference voltage is taken from a wiper of P1 and is applied to pin 3 of each IC. The low reference voltage is taken from the wiper of P2, to pin 16 of each IC. Since P2 derives its voltage from the wiper of P1 the low reference voltage can never be higher than the high reference voltage.

Parts List

Resistors:

R1 = 1k5
R2 = 1 M
R3 = 1 k
R4, R4' = 10 k
R5 = LDR
P1 = 10 k preset
P2, P3, P3' = 100 k preset

Capacitors:

C1 = 10 μ 35 V tantalum

Semiconductors:

D1... D12, D1'... D12' = LED
(e.g. TIL 209)
D13, D13' = DUS
D14 = 4V7/400 mW zener
IC1, IC2 = UAA 180

Miscellaneous:

2 x 18 pin IC sockets or 36 way socket strip.

D14 also provides input protection for the ICs. The maximum allowable input voltage to the UAA 180 is 6 V. If the voltage on the wiper of P3 exceeds this then the voltage at the IC input will be clamped to about 6 V by D13 and D14. The same is true of the R input. Input voltages in excess of 6 V are accommodated by using P3 or P3' to attenuate the input voltage to below 6 V at the IC input.

Automatic adjustment of the display brightness to suit ambient illumination is provided by connecting an LDR, R5, between pin 2 of the ICs and positive supply. R2 and R3 serve to limit the range of display brightness. If this facility is not required then these components may simply be omitted, leaving pin 2 floating.

Construction

Printed circuit board and component layouts for the voltmeter module and LED array are given in figures 3 and 4. The LED board is simply mounted at right angles to the main board using wire links. As mentioned earlier, the suppressed-zero facility makes it possible to extend the display length by using two or more ICs per channel. To facilitate this the supply connections, brightness control (A), and L and R inputs are duplicated at both ends of the p.c. board so that two or more boards may be stacked together as shown in figure 5. The following components need be provided only on one of the boards, and may be omitted from the other board — P5, P3', R2, R3, R5,

5

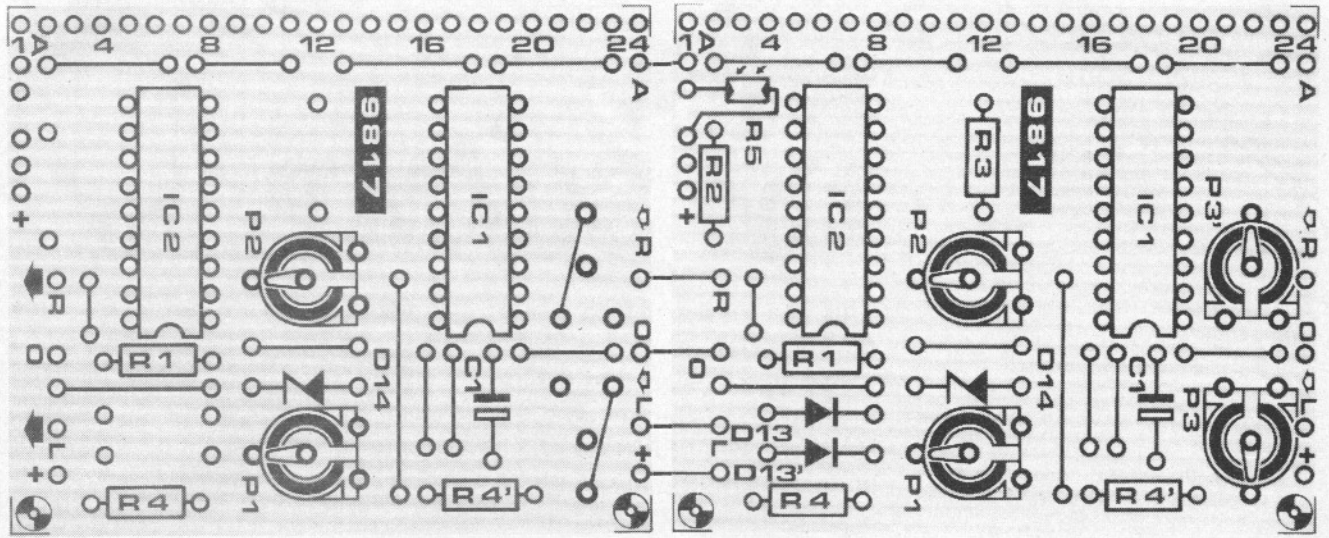

D13 and D13'. These components have been omitted from the left-hand board of figure 5. It is also necessary to connect links in place of the omitted P3 and P3' as shown, and to provide links between the adjacent +, 0, L, R, and A connections on the two boards.

Calibration

The LED voltmeter may be calibrated against an ordinary multi-range test meter. However, a small complication exists because the value of the reference voltage affects the manner in which the LEDs turn on. When the voltage between pins 2 and 16 of the IC is the maximum (5.6 V) then each LED will turn on abruptly. At lower reference voltages, however, the LEDs turn on more gradually. The calibration procedure given uses the maximum possible reference voltage, and if other reference voltages are required to suit individual requirements then the procedure must be adapted accordingly. It is assumed that both channels of the meter will be calibrated to the same range.

For input voltages up to 6 V the calibration procedure is as follows:

1. Using a multimeter, set the wiper voltage of P1 about 10% below the maximum input voltage.
2. Feed in the maximum input voltage to be measured and adjust P3 until all LEDs are lit (top LED in the column being just lit).
3. Feed in the minimum input voltage that is to be measured and adjust P2 until only the first LED is lit.
4. Check the adjustment of P3.

Table 2.

Typical operating parameters of the UAA 180.
 Supply voltage: 10 to 18 V
 Supply current, excluding LEDs: 5.5 mA
 Input currents (reference voltage between pins 3 and 16 less than 2 V):
 pin 3: 300 nA
 pin 16: 300 nA
 pin 17: 300 nA
 Current per LED: 15 mA
 Current consumption of the two-channel voltmeter board:
 12 V supply: 75 mA, all LEDs lit
 15 V supply: 80 mA, all LEDs lit

Figures 3 and 4. Printed circuit boards and component layouts for the UAA 180 LED voltmeter (EPS 9817). The display board is mounted at right-angles to the main board using wire links.

Figure 5. The display may be extended to 24 or more LEDs by stacking two (or more) boards end-to-end as shown in this figure.

Table 2. Typical operating parameters of the UAA 180.

5. Repeat (2) for the right channel. For input voltages in excess of 6 V the following procedure is adopted:

1. Set P1 to maximum.
2. Feed in the maximum voltage to be measured and adjust P3 until all LEDs are lit (top LED in the column being just lit).
3. Feed in the minimum voltage to be measured and adjust P2 until only the first LED is lit.
4. Check the adjustment of P3.
5. Repeat (2) for the right channel.

For extended versions of the voltmeter the adjustment procedure must be duplicated for the voltage ranges covered by the first and second modules. Care must be taken to ensure that the first LED of the second module lights at exactly the right voltage. It should not light before the last LED of the first module lights, nor should there be too great a gap between the last LED of the first module lighting and the first LED of the second module.

Applications

Use of the LED voltmeter with the PPM drive circuit to form an audio level meter is described elsewhere in this issue. Another interesting application is to use the voltmeter with a temperature-to-voltage converter (such as circuit No. 5 in the July/August 1977 issue) to form a novel thermometer.

experimenting with the SC/MP (3)

Interrupt operations

An interrupt operation occurs when an externally generated control signal causes the SC/MP temporarily to suspend main programme execution. The interrupt request will typically be issued by a peripheral device such as, e.g., a display which requires refreshing. When the CPU acknowledges such an interrupt, it jumps from the main programme to a special routine to service the interrupting device — after saving the return-to-main programme address. Once the interrupting device has been serviced, the CPU automatically resumes main programme execution. This process is illustrated in figure 1. Note that, in principle, an interrupt routine is quite similar to a subroutine call, except that the jump is initiated externally by an interrupt request rather than internally by an instruction in the current programme.

The situation becomes more complicated when the CPU receives several interrupt requests more or less simultaneously and has to choose between more than one interrupt routine. When this happens the CPU basically has two ways of servicing the interrupts: the first is to run the routines sequentially, the second is to 'nest' the interrupt routines in order of priority.

In the former case the CPU first determines the source of the interrupt request then jumps to the appropriate routine. Whilst the CPU is executing this routine the interrupt input is inhibited, so that it will not respond to any further interrupts. Once the service routine has been completed the CPU resumes main programme execution. However, if the CPU is then presented with a second interrupt request, it will once more automatically branch to the required subroutine. The problem of several interrupt requests occurring whilst the CPU is already executing an interrupt routine is solved by means of a priority encoder which assigns a different priority to each interrupt source. The CPU must therefore be able to interrogate the encoder so as to determine the relative priority of the various interrupting devices. Figure 2a shows the sequence of subroutines; in this example routine '0' has the highest

This, the third article in the SC/MP series, introduces the memory extension card, which, in addition to containing ¾ k of RAM and ½ k of PROM, also houses the multiplexer and priority encoder. The latter hardware allows the SC/MP to handle interrupt requests from more than one peripheral device. The article also examines the software involved in interrupt operations.

H. Huschitt

priority.

In the case of nested interrupts, the interrupt system is re-armed immediately upon the CPU branching to an interrupt routine, so that a second interrupt request can be acknowledged by the CPU at any time. Assuming, for example, that the CPU is already executing an interrupt routine when it detects a second interrupt request from a higher priority source, it will first branch to the routine which will service that device, then return to complete the initial interrupt routine, and only then return to the main programme (see figure 2b). During a routine the CPU will not acknowledge an interrupt request from a lower priority source.

Jumping from one programme to another does not, in itself, present any special problems; one must simply ensure that the contents of the various CPU registers are not lost when branching to a subroutine, otherwise the original programme could not be executed properly. To preserve the status of the CPU's internal register values, they are stored in a stack. This stack consists of several general-purpose registers which store data on the principle of last-in/first out ('lifo'). Some microprocessors possess an integrated stack register, whilst others have instructions* which permit a stack to be programmed into the RAM.

SC/MP interrupt system

The SC/MP has only one interrupt input (Sense A). When the internal interrupt enable (IE) flag is set, by executing either an Enable Interrupt Instruction (IEN) or a Copy Accumu-

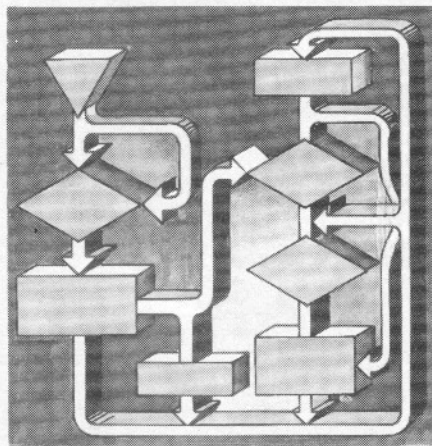

* In several microprocessors one machine instruction results in the CPU carrying out a large number of separate steps. Think, for example, of how many operations are involved in a DLY instruction in the case of the SC/MP. The name for the total number of steps involved in a single machine instruction is a 'micro-programme'. Computers and some microprocessors are 'micro-programmable', i.e. the micro-programme, and so the instruction set, can be altered to suit a special application. Naturally this technique requires a profound knowledge of the architecture of the CPU in question.

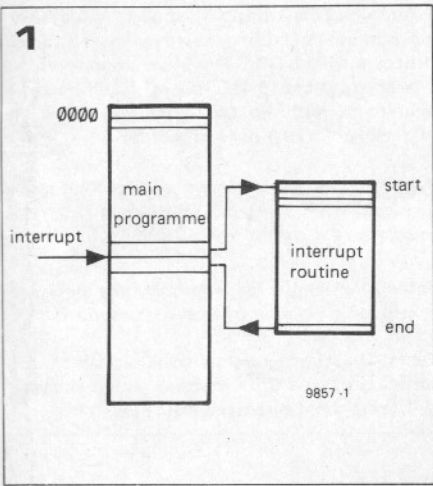
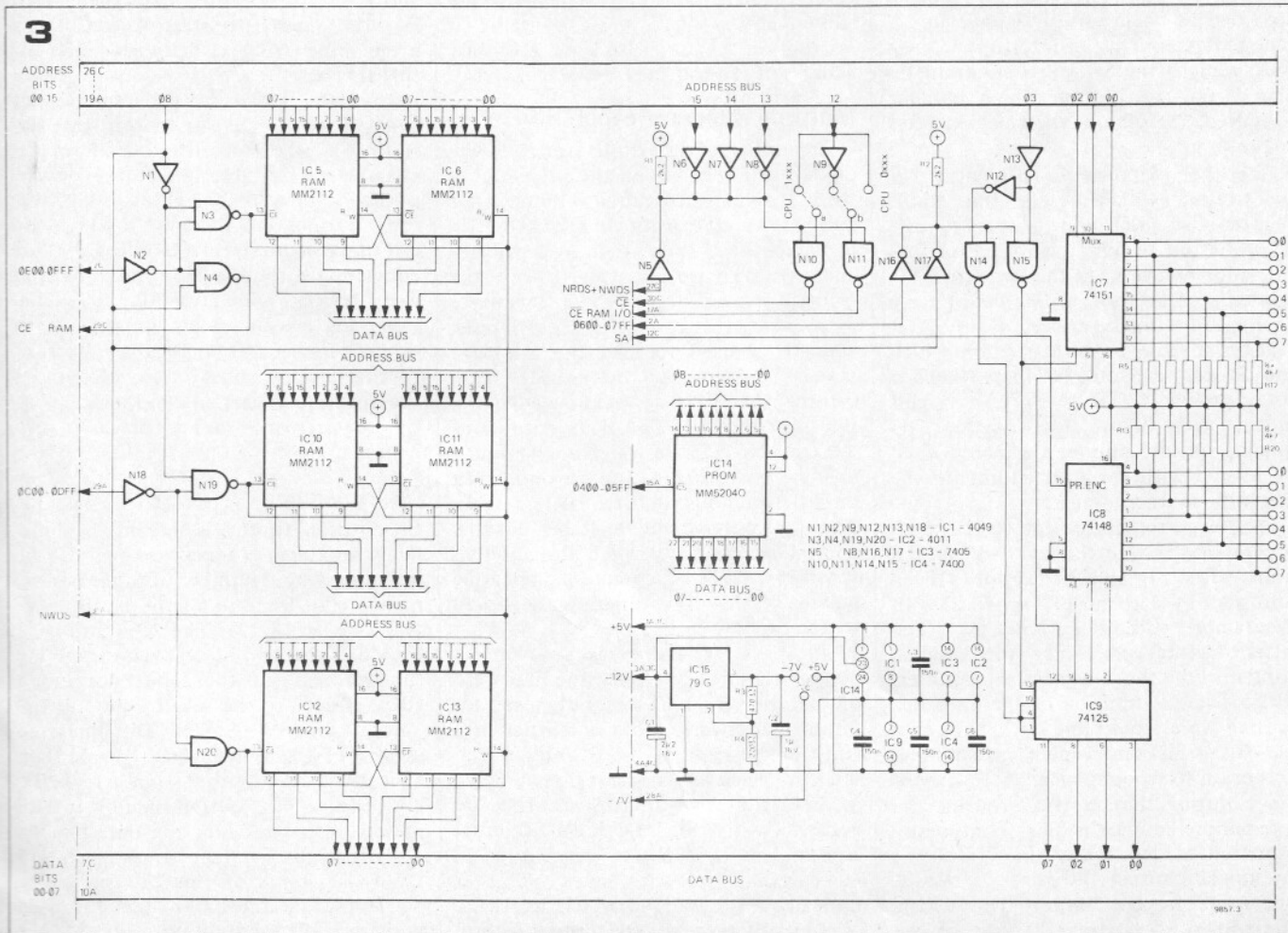
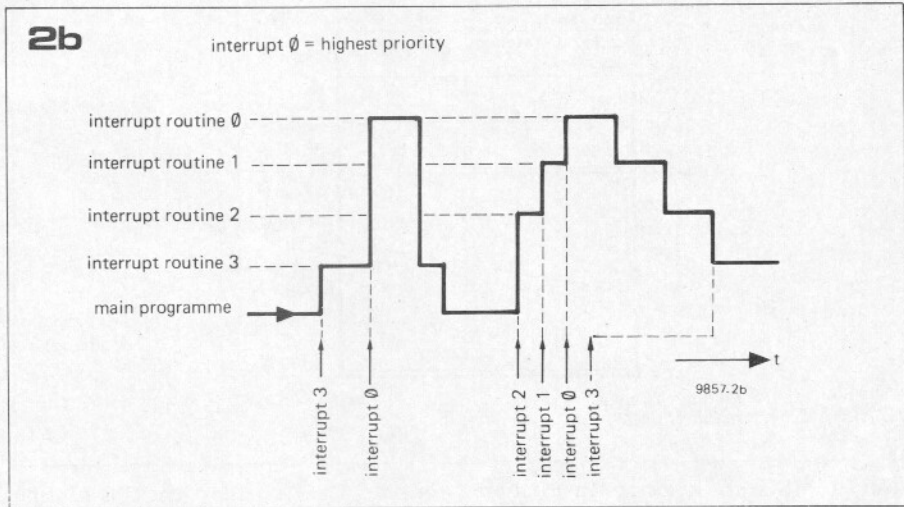
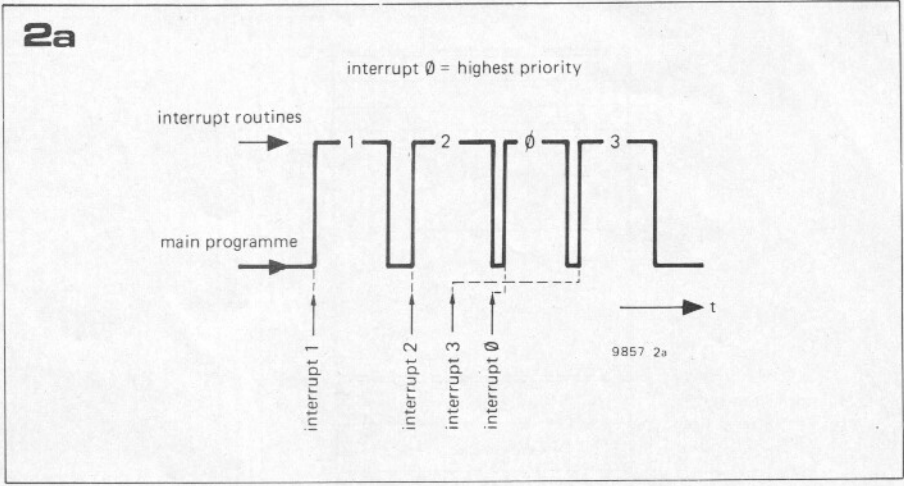

Figure 1. Diagrammatic representation of an interrupt operation.

Figure 2. These examples illustrate the two basic methods of servicing multiple source interrupts.

Figure 3. Complete circuit diagram of all the hardware housed on the second Eurocard.



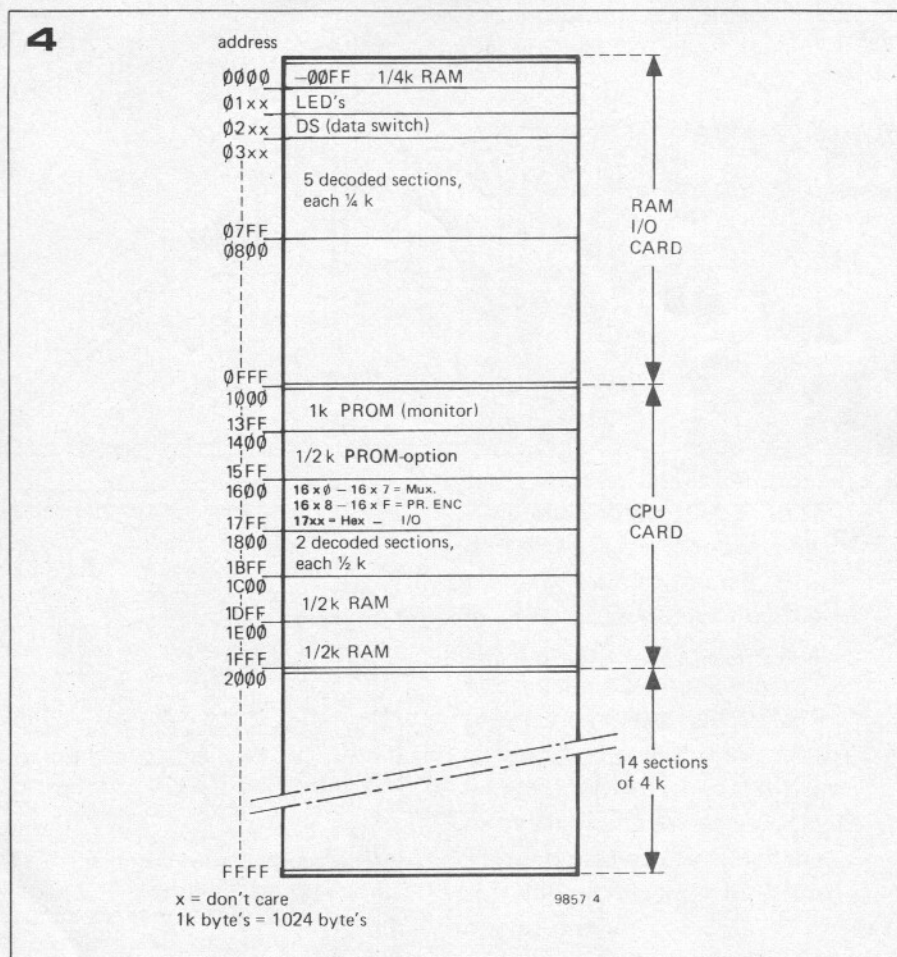

Figure 4. This diagram shows a detailed breakdown of the current page-address structure of the SC/MP system's memory. At a later stage the RAM I/O card will become redundant, and the CPU card will move up to occupy the first page of memory.

Table 1. This table shows the various steps involved in entering and exiting an interrupt routine in the case of the SC/MP.

Table 2. Example of a programme designed to process a number of interrupt requests.

Table 3. A programme which enables the contents of the CPU registers to be checked by having them displayed on LEDs.

Table 1

INT:	:	label of interrupt routine
•	}	interrupt routine proper
•		
•		
IEN	:	enable interrupts
XPPC 3	:	return to main programme
JMP INT	:	jump to start address of interrupt routine

lator to Status Register Instruction (CAS), the Sense A line is enabled to serve as an interrupt request input. Upon detection of an interrupt request (SA is high) the SC/MP first completes the current instruction which is being executed before acknowledging this request.

There then follows an internal DINT Instruction which resets the status register flag (IE), thus preventing the SC/MP from responding to any further interrupt requests. At the same time the contents of the programme counter are exchanged with the contents of pointer register 3. The next instruction which the SC/MP executes is that which is found under the address (PC) + 1. This means that before the interrupt sequence begins, pointer register 3 must be loaded with the start address of the interrupt routine minus 1.

The return from interrupt to the main programme is effected by two instructions: first Enable Interrupt (IEN), followed by Exchange Pointer 3 with Programme Counter (XPPC 3). The latter instruction copies the original contents of the programme counter, which for the duration of the interrupt routine were stored in PTR 3, back into the PC, allowing main programme execution to recommence.

Since during the interrupt routine the programme counter is being continually incremented, this means that PTR3 will no longer contain the start address of this routine, but rather the address immediately following the end of the

routine. Thus in order that this routine can, if necessary, be repeated, the subsequent address must contain an instruction to jump back to the start address of the routine (see table 1).

Multiple interrupt capability

The number of interrupt inputs of the SC/MP can be extended fairly simply to 8. All that is required is some extra hardware in the form of a 74148 (IC8 in figure 3) that is used as a priority encoder. The output (pin 15) of the priority encoder goes high whenever a '0' appears at one of its eight inputs. This '1' is used to take the interrupt input (Sense A) of the SC/MP high, causing the CPU to acknowledge the interrupt request. The BCD outputs of the encoder indicate which of the inputs is low. This information is routed out onto the data bus via three buffers (IC9). The 0 input of the encoder has the highest priority, i.e. when this input is taken low, interrupt requests appearing at any of the other inputs are ignored by the SC/MP.

To be able to service several interrupting devices requires not only the hardware of a priority encoder, but also additional software. This is particularly true in the case of the SC/MP, which does not have any stack registers. Thus, in the event of an interrupt routine the contents of the SC/MP's internal registers must be temporarily stored in an external 'software stack'. This is basically a programme which loads the contents of these registers into a section

of memory reserved for this purpose, and after the routine, loads them back into the original registers. A part of this programme will be discussed later in this article.

Before the interrupt programme can begin the CPU must first interrogate the state of the priority encoder. An example of suitable interrupt software is shown in table 2. The actual interrupt routines and the way in which the interrupt requests are handled will of course depend upon the type of peripheral devices which require servicing. For this reason it is impossible to provide universally applicable interrupt routines, these must be developed by the individual user in accordance with the requirements of his particular programme.

Multiplexer

In addition to the 8 interrupt inputs, main programme execution can also be influenced by a number of other inputs, namely the 8 inputs of the multiplexer IC7 (see figure 3). The logic state of each of these can be tested by applying the 'address' of the input concerned (BCD-coded) to the select inputs of the 'Mux' (pins 9...11). The inverted version of the selected input signal then appears at the output (pin 6) of the multiplexer. This output data bit is then pulsed onto bit 07 of the data bus via a tri-state buffer. Bit 07 was chosen since the status of this bit can easily be tested by means of the Jump If Positive (JP) instruction. The SC/MP

Table 2

```

MAIN PROG:
DINT                                ; disable interrupts
.
.
.
LDI L (STACK)
XPAL2                                ; section of main programme with
LDI H ($STACK)                       ; SC/MP inhibited from detecting
XPAH2                                ; interrupts
LDI L (INTIN)-1
XPAL3                                ; load PTR 2 (stack pointer) with
LDI H (INTIN)                         ; address of RAM stack
XPAH3                                ; load PTR 3 with address of multiple
IEN                                  ; interrupt routine
.                                    ; enable interrupts
.
.
INTIN:                               ; section of main programme where
.                                    ; interrupt is possible
.                                    ; Label for multiple interrupt routine
.
.
.
LD PRIOR                             ; interrogate priority encoder
ANI 07                               ; mask out number of routine
XAE                                  ; and store in E
LDE
XRI 00                               ; was the number 0?
JZ INT 0                             ; if yes, jump to INT 0
LDE
XRI 01                               ; was the number 1?
JZ INT 1                             ; if yes, jump to INT 1
LDE
.
.
.
etc.
INT 0:                               ; label for routine '0'
IEN                                  ; only for nested interrupts
.
.
.
.
JMP INTOUT                           ; jump to INTOUT routine
INT 1:                               ; label for routine '1'
IEN                                  ; only for nested interrupts
.
.
.
.
etc.
INTOUT:
.
.
.
.
IEN                                  ; only for sequential interrupts
XPPC3
JMP INTIN                            ; only for sequential interrupts
    
```

Table 3

```

START = 0000
0000 08    NOP
0001 C454  LDI L
          (SAVSTA)-1
0003 33    XPAL3
0004 C400  LDI H
          (SAVSTA)          ; load PTR 3 with the
                          ; address of SAVSTA
0006 37    XPAH3          ; the programme under test
                          ; is loaded from 0007 on
0007      XPPC3          ; load XPPC3 into the
                          ; address immediately
                          ; following the 'suspect'
                          ; section of programme
                          ; Label of SAVe SStatus
                          ; routine
          SAVSTA:
0055 C837  ST AC          ; store (AC) in RAM
0057 01    XAE
0058 C835  ST E          ; copy (E) to RAM
005A 06    CSA          ; (SR), etc.
005B C833  ST SR
005D 31    XPAL1
005E C831  ST P1L
0060 35    XPAH1
0061 C82F  ST P1H
0063 32    XPAL2
0064 C82D  ST P2L
0066 36    XPAH2
0067 C82B  ST P2H
          MUX:          ; Label for multiplex routine
0069 C400  LDI L (MUX)
006B 31    XPAL1
006C C416  LDI H (MUX)  ; load PTR 1 with the address
006E 35    XPAH1        ; of Mux
006F C401  LDI H (LED) ; load PTR 2 with the address
0071 36    XPAH2        ; of the LEDs
0072 C48D  LDI L (AC)
0074 33    XPAL3
0075 C400  LDI L (AC)  ; load PTR 3 with stack
0077 37    XPAH3        ; address
          LOOP:
0078 C407  LDI 07      ; prepare counter to in-
007A C811  ST COUNT    ; terrogate the Mux
          NEXT:
007C B80F  DLD COUNT   ; decrement counter and
007E 01    XAE        ; load E for indirect
                          ; addressing
007F C180  LD X'80 (1) ; load Mux input 0... 7
0081 94F9  JP NEXT     ; if addressed input active,
                          ; continue
0083 C008  LD COUNT    ; load counter state into E
0085 01    XAE        ; and display desired
0086 C380  LD X'80 (3) ; (register) contents on LEDs
0088 CA00  ST 0 (2)
008A 90EC  JMP LOOP
008C 00    COUNT:
          .BYTE
008D 00    AC:          ; RAM-byte for (AC) stack
          .BYTE
008E 00    E:          ; ditto for (E)
          .BYTE
008F 00    SR:
          .BYTE
0090 00    P1L:       ; etc.
          .BYTE
0091 00    P1H:
          .BYTE
0092 00    P2L:
          .BYTE
0093 00    P2H:
    
```

5

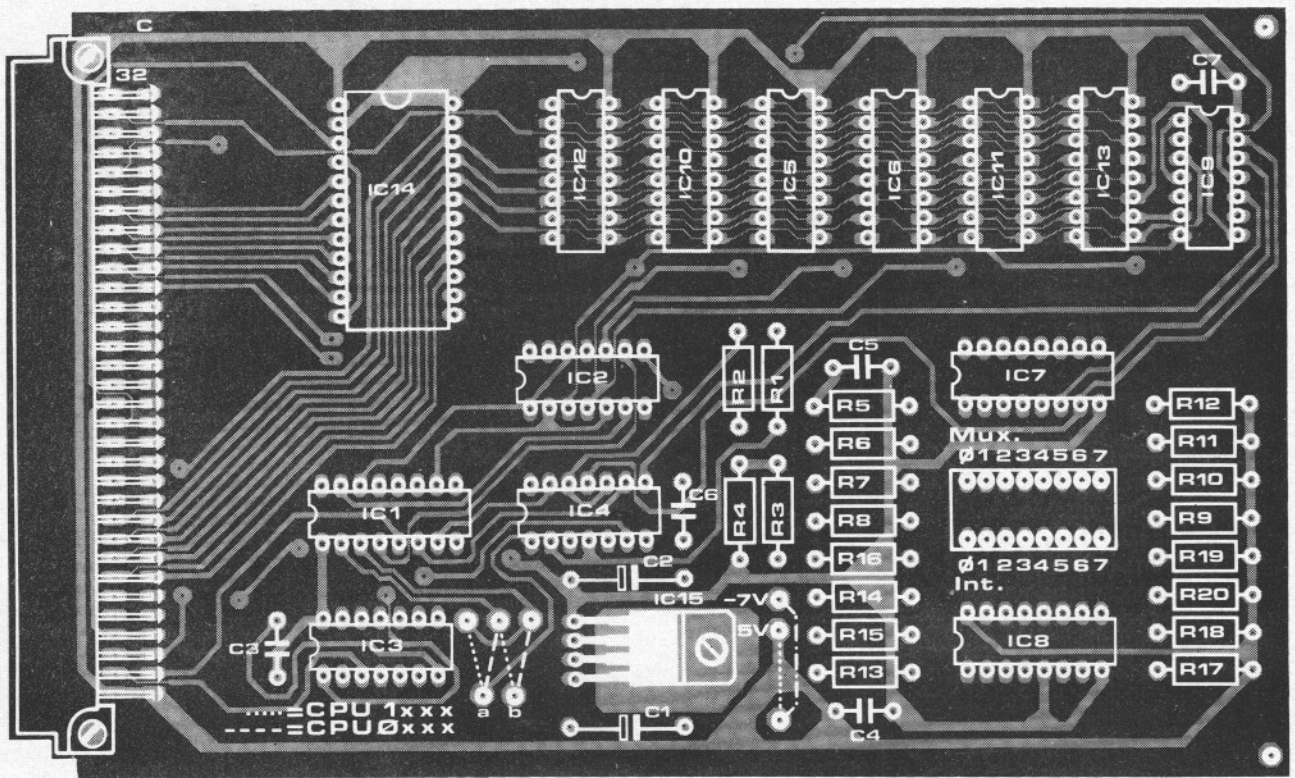
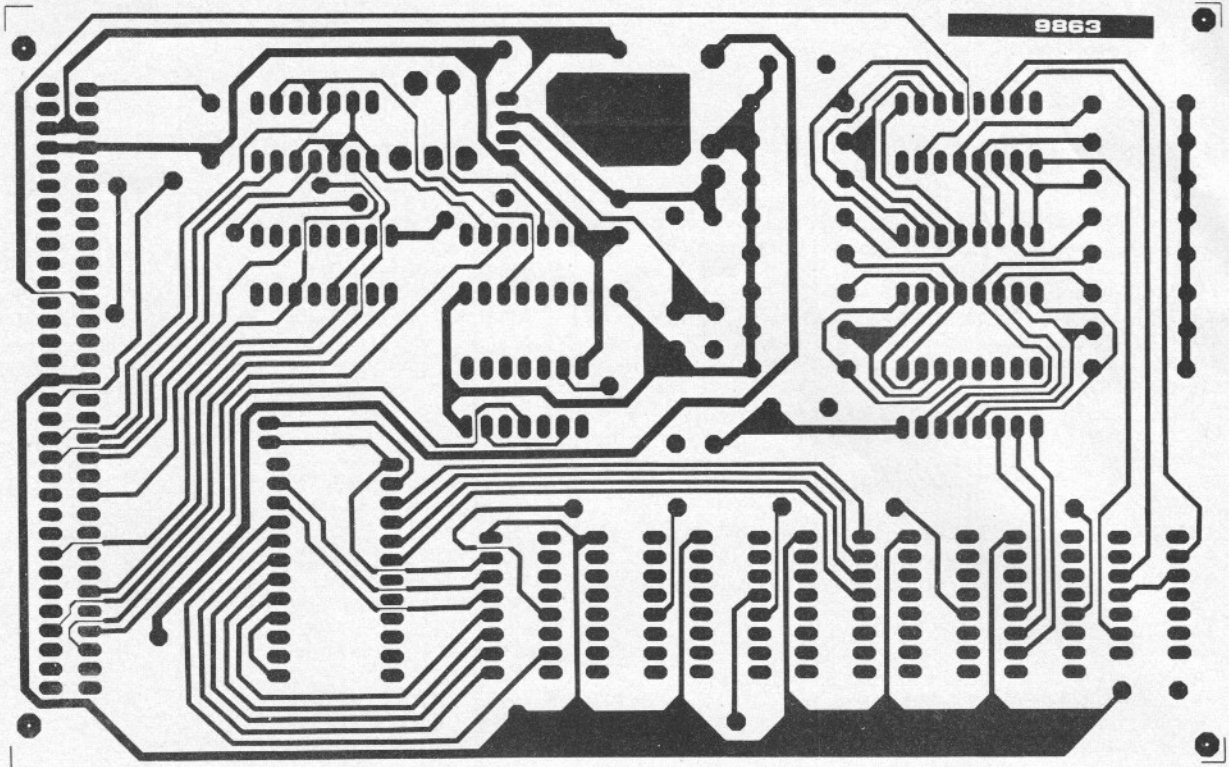

Parts list to figures 3 and 5

Resistors:

- R1,R2 = 2k2
- R3 = 470 Ω*
- R4 = 220 Ω*
- R5 ... R20 = 4k7

Capacitors:

- C1 = 2.2 μ/16 V
- C2 = 1 μ/16 V*
- C3 ... C6 = 150 n

Semiconductors:

- IC1 = 4049
- IC2 = 4011
- IC3 = 7405
- IC4 = 7400
- IC5,IC6,IC10 ... IC13 = 2112
- IC7 = 74151
- IC8 = 74148
- IC9 = 74125
- IC14 = MM 5204Q
- IC15 = 79G*

* omitted for SC/MP II

6

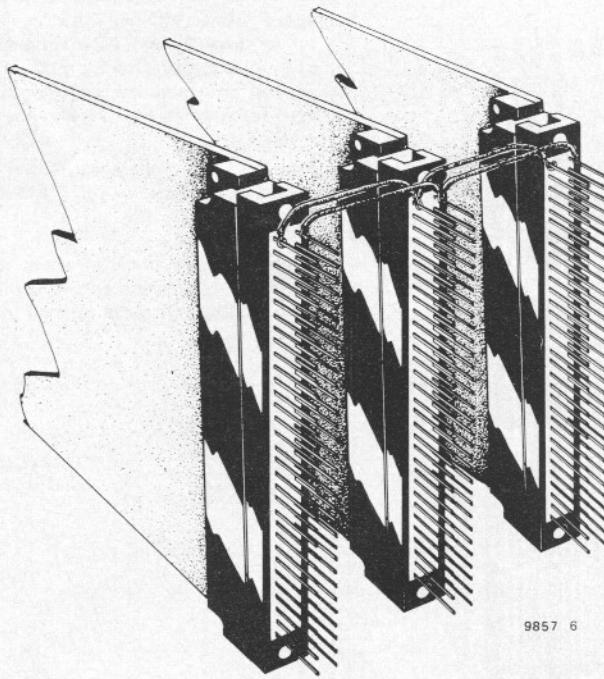

Figure 5. The track pattern and component layout of the printed circuit board for the memory card (EPS 9863). Particular attention should be paid to the wire link to the right of IC15: when using the earlier P-MOS SC/MP, this link should be in the '-7 V' position; for SC/MP II it should be in the '5 V' position.

Figure 6. To interconnect the Eurocards, a connector bus can be formed by joining the corresponding pins of the socket connectors using wire links.

will jump if this bit is '0' (i.e. a positive number), and continue main programme execution if it is '1'. An example of the software involved when utilising the multiplexer is shown in the programme listed in table 3.

Page-address structure

As the volume of system hardware continues to grow with the addition of the memory card (shown in figure 3), so the need to clarify the address structure of the system becomes more urgent.

The CPU card already contains a large portion of the memory capacity of the system (e.g. the PROMs for the monitor software), which, naturally enough, must be capable of being addressed. The CPU card is therefore supplied with an address decoder. With the advent of the additional memory capacity represented by the circuit in figure 3 the page-address structure of the system's memory takes the form shown in figure 4.

Half of the first memory page (0000 - 0FFF) can be addressed by the address decoder of the RAM I/O card. However, since the address decoding on the RAM I/O card is incomplete (AD11 is not decoded) the second half of this page is identical to the first half and cannot therefore be used for additional hardware.

The second memory page contains everything which can be addressed by the address decoder of the CPU card. This consists firstly of the two PROMs for the monitor software. To provide the option of expanding the monitor software, space is provided for a third (½ k) PROM (IC14 in figure 3). The section from 1600 to 17FF is reserved for the multiplexer with priority encoder and for the hexadecimal input/

output (HEX I/O) hardware which will be appearing shortly. The remaining lines of the second page are taken up by a 1 k RAM, ¼ k of which is present on the CPU card, with ¾ k situated on the memory card as shown in figure 3.

Once the hexadecimal input/output has been incorporated into the SC/MP system, the RAM I/O card will become largely redundant. Once the user has acquired a certain degree of proficiency with the system he can be expected to dispense with the RAM I/O card completely. For this reason it is also possible to construct the system without the RAM I/O card. This is done by switching the wire links a and b (shown as dotted lines in figure 3) to their alternative positions, so that the first memory page is now addressed by the address decoder of the CPU. Everything which in figure 4 lies between 1000 and 1FFF is then situated between 0000 and 0FFF.

Board interconnections

The complete circuit diagram of the memory-extension card is shown in figure 3. The track pattern and component layout of the printed circuit board for this card are shown in figure 5. This board, like the CPU card, is double-sided with plated-through holes, and conforms to Eurocard dimensions. It should also be fitted with a 64-way edge connector. The board houses a regulator IC (IC15) which supplies the negative voltage for the earlier, PMOS version of the SC/MP (see Elektor 32, p. 12-08: SC/MP II and the p.c. board). If SC/MP II is used, IC15, R3, R4 and C2 can be omitted; the wire link adjacent to the position for this IC is then connected to the point marked '5 V'. In order to interconnect the various

Eurocards, a 'connector bus' is necessary. This basically is nothing more than a number of socket connectors with the corresponding pins (all pins 1a, all pins 1b, etc.) interconnected. This arrangement is illustrated in figure 6.

Whilst it is entirely possible to make all the necessary connections in this fashion (using e.g. 'wire-wrapped' links), such a method is both time-consuming and error-prone. For this reason a 'bus board', which can accommodate three socket connectors, was designed (see figures 7 and 8). The CPU card and the memory card can then be interconnected by simply plugging them into the bus board. This bus board must of course be able to communicate with the RAM I/O card. Since the RAM I/O card does not use edge connectors, these connections must be hardwired. The wiring details are provided by figure 9.

Termination points to the bus lines are provided at each end of the board so that several bus boards can be stacked end to end and linked to extend the system. The layout of these termination points allows the addition of extra 64-way sockets so that external connections need not be hard wired.

The only major limitation to large scale expansion of the system is that imposed by the power supply. Anyone who plans a large system should bear in mind that each page of memory (4 k) consumes a current of approximately 1 A. A suitable 5 V/3 A, -12 V/0.5 A supply will be published in the near future.

Software

It will not have escaped most readers that the role played by software in this series of articles is gradually growing in importance. The reason for this is twofold: firstly the 'intelligence' of a

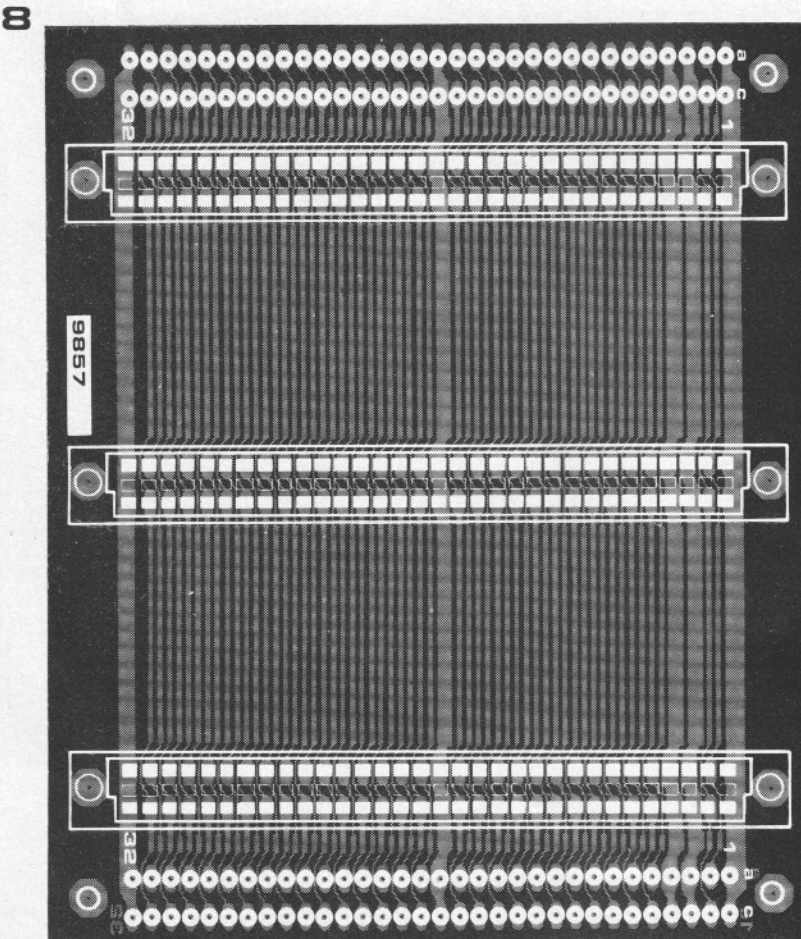
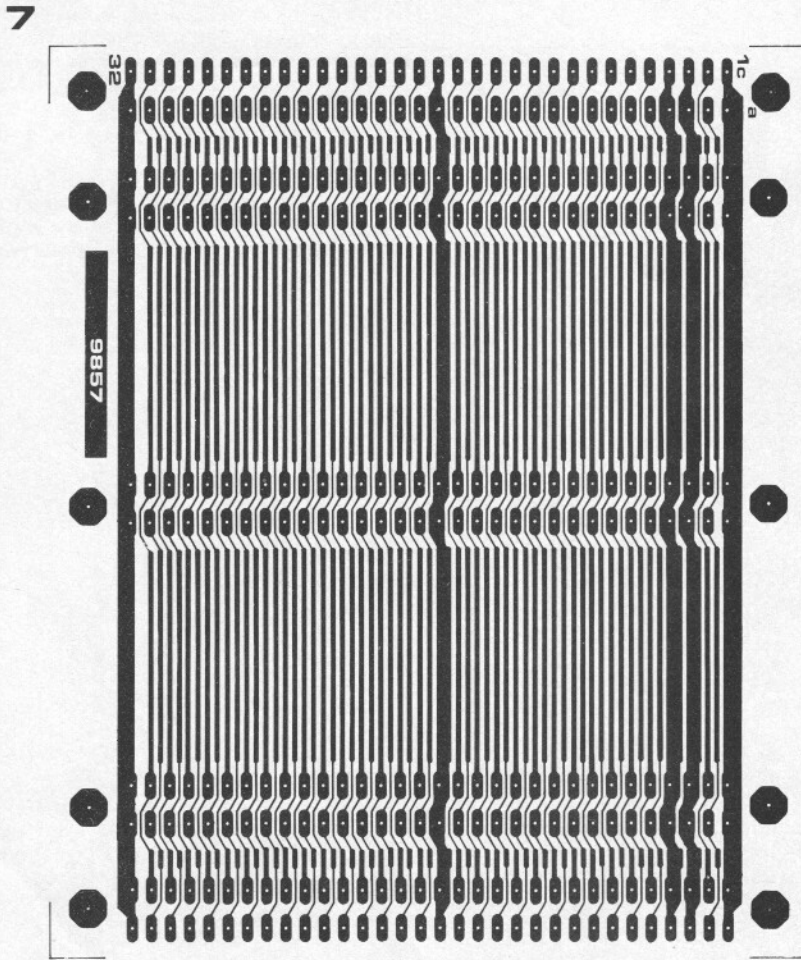

Figures 7 and 8. A more convenient method of linking the Eurocards is to use this 'bus board' (EPS 9857) which can accommodate up to three 64 pin edge connectors. Several bus boards may also be stacked together to expand the memory capacity of the system even further.

Figure 9. This diagram shows the wiring connections between the RAM I/O card and the bus board.

Figure 10. By means of a multiposition switch it is possible to display the contents of each CPU register in turn on the LEDs.

computer system is largely determined by the number and type of programme at its disposal; secondly, it is through developing his own software that the user can best appreciate the true potential of his system.

To this end, the present article concludes with a short 'debug' programme which will display the contents of the CPU registers at any stage during the programme under test. This is done by replacing the instruction which immediately follows the 'suspect' section of the programme by XPPC 3 (3F). The programme under test is then started as normal, after an NRST instruction. When the programme reaches the XPPC 3 it jumps to a 'save status routine' and writes the contents of the CPU registers into the RAM. The Mux inputs are connected to a multiposition switch (see figure 10), by means of which the register whose contents are to be displayed on the LEDs can be selected. In this way the contents of each CPU register, with the exception of course of PTR 3 and the PC, can be examined in turn.

The programme in its present form can only be exited from by means of an NRST instruction. A more sophisticated and convenient version of the programme will later be incorporated into the monitor software.

9

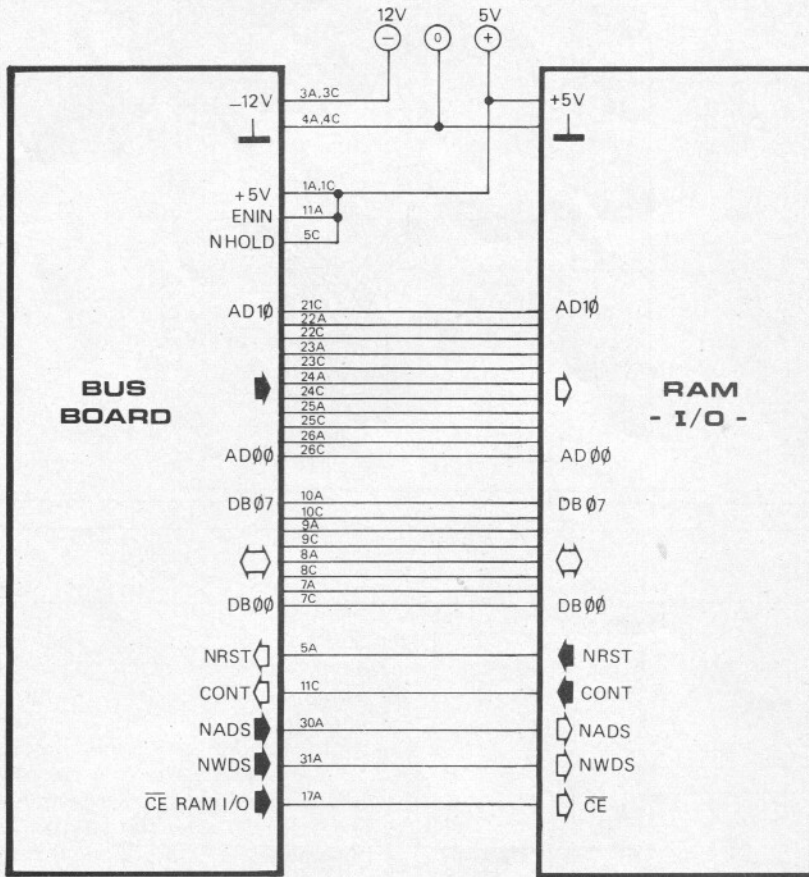

9857 9



Modifications to
Additions to
Improvements on
Corrections in
Circuits published in Elektor

Formant - the Elektor music synthesiser

Parts 4 and 5, October and November 1977. In Part 4, R1 in the input adder circuit (figure 7) is shown as 100 k. This gives the 'Octaves, coarse' control (P1) a range of $\pm 7\frac{1}{2}$ octaves. At a later date, it was decided to reduce this range to ± 5 octaves. In part 5, this modification was carried out: in figure 2a, R1 is shown as 150 k; the front panel layout (figure 3) shows a 'coarse' range from -5 to +5.

However, we forgot to point out that the value of R1 shown in figure 7 of part 4 is 'incorrect'. Furthermore, and more seriously, the Octaves/Volt adjustment was based on the original value of R1. This means that the *Octaves/Volt adjustment procedure described in part 5 is incorrect*.

For the adjustment procedure using a DVM and a frequency counter, the connection between the slider of P1 and R1 must first be unsoldered. The free end of R1 is then connected to ground, and the slider of P1 is connected to the KOV input with S1 in position 'a'. Adjustment can now proceed as described in the original article.

The second adjustment procedure, using the beat note method, is correct as originally described.

10

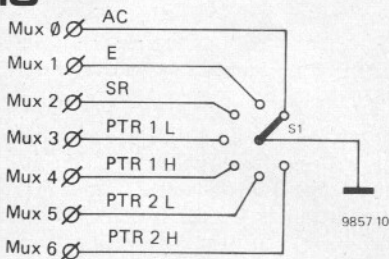

The listing for this programme is given in table 3. The 'save status routine' can also be used for interrupt operations. In this case the section of RAM from 008D...0093 is used to form a software stack.

The majority of the instructions contained in this programme have already been discussed and require no further explanation. One important exception however is the 'indirect' address mode utilising the extension register. As explained in part 1 ('address modes'), indirect addressing describes the address mode whereby the effective address (EA) is obtained by incrementing the contents of a pointer by the contents of a byte taken from the RAM. In the case of the SC/MP this can only be done with the aid of the extension register. When the displacement value is X'80, then (for memory reference instructions) it is no longer used to obtain the effective address, but is replaced by the contents of the extension register. The contents of the extension register are not known at the time of entering the programme, but are determined during execution of the programme. In this programme the indirect address mode results in a considerable saving in the number of instructions.

(to be continued)

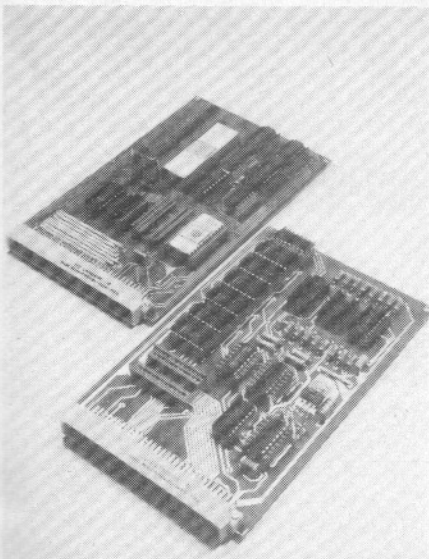

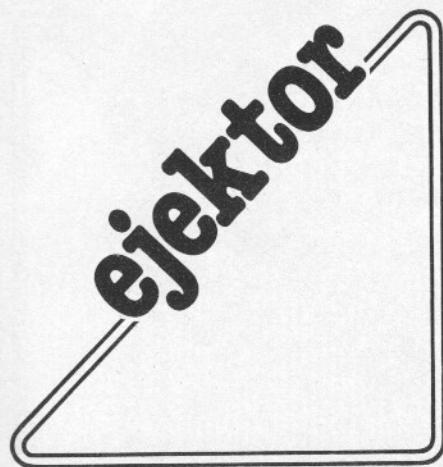

an invitation to investigate, improve on and implement imperfect but interesting ideas.

third octave filters

In the article on the Elektor equaliser (see elsewhere in this issue) it was noted that third octave filters represented a more ideal solution to the problems of room equalisation, but that their complexity meant they were prohibitively expensive to build and use in a system which covered the entire audio spectrum. For this reason they were discarded as a suitable basis for the Elektor equaliser. Rather than throw out the baby with the bath water however, various less complex arrangements of a third octave filter system were examined in an attempt to find a more financially viable application. The following circuit provides a reasonably acceptable solution.

2a

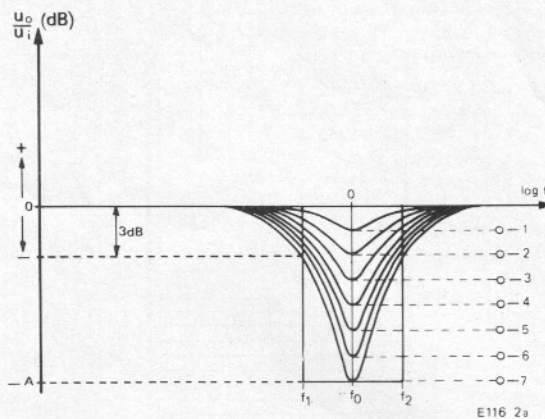

2b

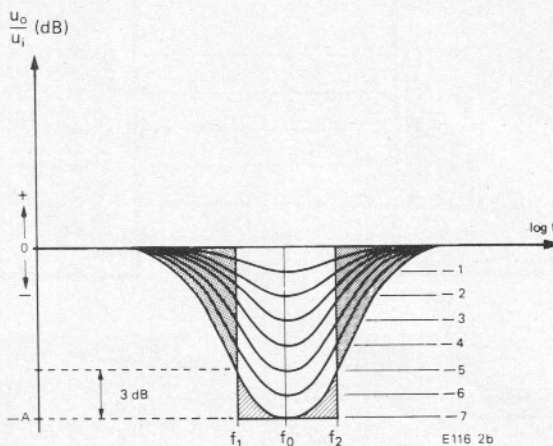

The basis of the compromise solution is shown in figure 1; this response differs from that shown in figure 2 of the equaliser article inasmuch as all the rectangular passbands lie below the 0-dB line. The filter therefore applies only stop (-7) of the appropriate filter potentiometer. Similarly, the curves shown in figure 2b correspond to the

The frequency response curves shown in figure 2a coincide with the lower half of figure 4 in the equaliser article; at the band edge frequencies f_1 and f_2 , the attenuation is -3 dB for the lower end stop (-7) of the appropriate filter potentiometer. Similarly, the curves shown in figure 2b correspond to the

1

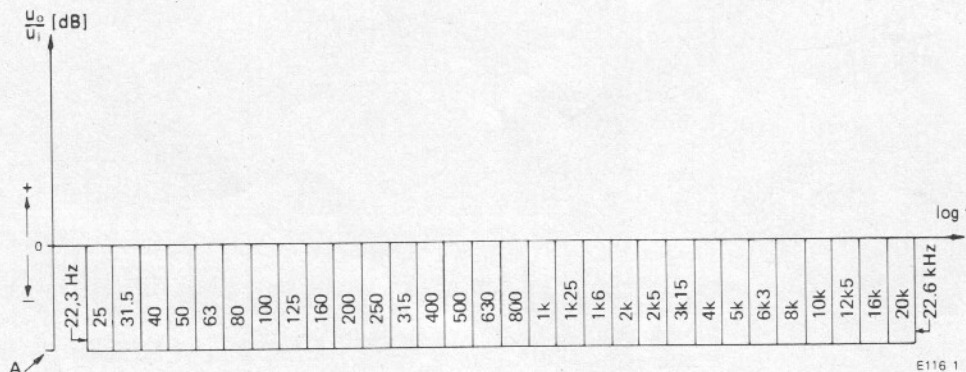

3a

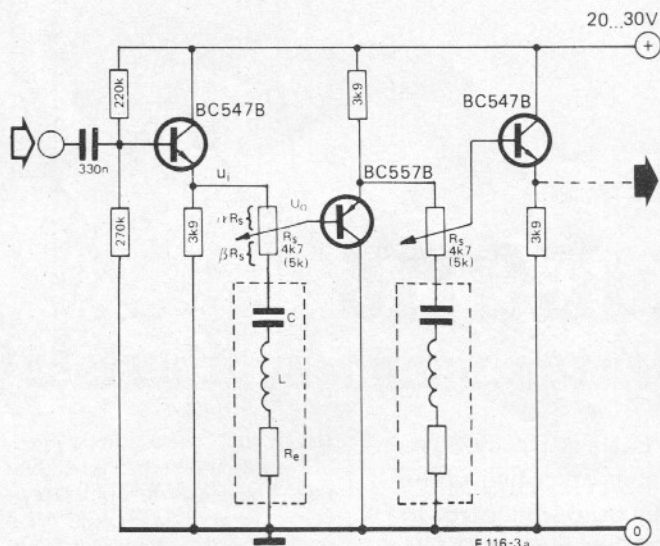

lower half of figure 5 in the equaliser article. The filters here, however, have one-third octave centre-frequency spacing, i.e. the frequencies f_1 and f_2 are nearer the centre frequency f_0 than in the case of octave filters.

As in the case of the Elektor equaliser, the relatively less selective filters (lower Q, see figure 2b) offer superior musical performance.

Figure 3a shows the circuit diagram of two cascaded filter sections. The filter proper consists of a series resonant circuit in series with the potentiometer resistance R_s . The filter input voltage u_i is supplied by an emitter follower. The output voltage u_o is taken from each filter section via the wiper of the potentiometer. Alternate PNP- and NPN-transistors should be used when cascading the different sections, since the base-emitter voltage drops of alternate stages are then of opposite polarity, and cancel out.

The emitter followers can be replaced by op-amps, which should then be connected as voltage followers; quad op-amps in particular should prove suitable for this task. To electronically synthesise the inductance, the circuit shown in figure 11 of the equaliser article (i.e. the modified version of the circuit in figure 9) is an obvious solution. A discrete-component equivalent is shown in figure 3b - basically a gyrator circuit.

A complete equaliser would consist of a cascade of 30 of these filter sections. However an alternative answer that is particularly appropriate in the case of a long filter chain, since it both reduces the number of active components and offers a superior signal-to-noise ratio, is to combine a number of filters whose centre frequencies f_0 are sufficiently far apart in the manner shown in figure 4. The values of R should be several times larger than those of R_s .

3b

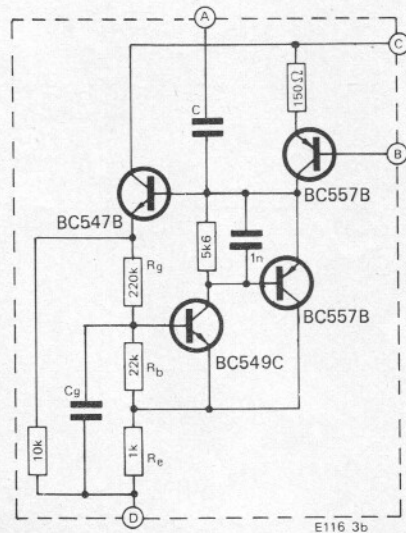

4

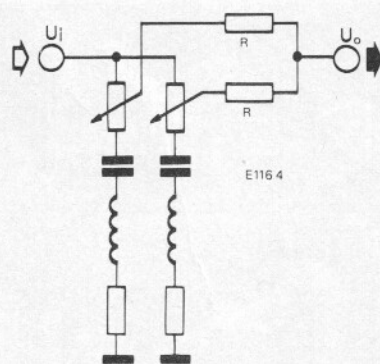

The frequency response curve of a filter section expressed mathematically is as follows:

$$\left(\frac{u_o}{u_i}\right)^2 = \frac{(1-x^2)^2 + \frac{K_1^2 x^2}{Q^2}}{(1-x^2)^2 + \frac{K_2^2 x^2}{Q^2}}, \text{ where}$$

$$x = \frac{f}{f_0}; f_0 = \frac{1}{2\pi\sqrt{LC}}; Q = \frac{1}{R_e} \sqrt{\frac{L}{C}};$$

$$K_1 = \frac{R_e + \beta R_s}{R_e}; K_2 = \frac{R_e + R_s}{R_e}; \alpha + \beta = 1$$

The gain at $f = f_0$ is $K_1 : K_2$. The value of K_2 is fixed, whilst K_1 depends upon the potentiometer setting β , and may vary between 1 and K_2 .

The maximum attenuation at f_0 is $-A$ dB = $-20 \log K_2$ dB.

The parameters of the series resonant circuit are:

$$f_0 = \frac{1}{2\pi\sqrt{LC}}; Q = \frac{1}{R_e} \sqrt{\frac{L}{C}};$$

$$L = R_e R_g C_g; C = \frac{1}{2\pi f_0 Q R_e};$$

$$C_g = \frac{Q}{2\pi f_0 R_g}$$

The value of Q is determined by the choice of the 3 dB points and by K_2 , therefore by the maximum attenuation at the centre frequency f_0 . In the case of third octave filters and with the 3 dB points shown in figure 2b Q equals

$$\frac{4.32 \cdot K_2}{\sqrt{K_2^2 - 2}}$$

If $R_s = 4k7$ and $R_e = 1k2$, then $K_2 = 4.92$ and $A = 13.83$ dB, from which follows that $Q = 4.51$. The values of the capacitors C and C_g can now be calculated.

Figure 1 can serve as basis for the choice of the centre frequency. It may be necessary to change the value of R_g somewhat in order to obtain a suitable value for C_g .

Literature:

J. Eargle: *Equalising the Monitoring Environment; Journal of the Audio Engineering Society, March 1973.*

D. Davis and D. Palmquist: *Equalising the Sound System to match the room; Electronics World, January 1970.*

Elektor equaliser, see elsewhere in this issue.

formant

the elektor music synthesiser (7)

It is often not realised, even by musicians, how much the character of an instrument is determined by the dynamic amplitude and harmonic behaviour, rather than by the steady-state harmonic content of the instrument. If the attack and decay periods of a note are artificially modified, then the whole character of the sound is altered. An interesting and amusing experiment is to record the sounds of several musical instruments, but to remove the attack and decay periods by bringing up the recording level after the note starts and fading it down before the note ends. Then ask some musical friends to identify the instruments. They will no doubt be amazed how characterless the sound of an instrument becomes when robbed of its particular amplitude envelope.

On the other hand, starting with a single basic waveform such as the triangle output of the Formant VCO, a whole range of instrument sounds can be produced simply by varying the amplitude envelope, ranging from 'soft' sounds such as flute and some organ voices, to 'hard', percussive sounds such as piano and xylophone.

Envelope control of the harmonic content using the VCF allows even greater variation in the character of the sound.

Types of envelope curves

The envelope shaper of the synthesiser must be able to simulate the envelope contour of conventional musical instruments when the synthesiser is used in an imitative capacity, and also to produce envelopes that are purely synthetic in character (i.e. not found in sounds produced by normal acoustic methods). Fortunately, there are relatively few types of envelope contour that are musically important, and these are all fairly easy to generate electronically.

1. Attack/decay contour

The simplest type of envelope curve is that consisting only of attack and decay periods. The envelope contour rises to a peak when the note is played, and begins to decay immediately the peak is passed (see figure 1). By varying the

The ADSR (Attack-Decay-Sustain-Release) shaper described in this article can be used to control the VCA and VCF to impart a wide range of tone colour and amplitude dynamics to the VCO waveforms.

C. Chapman

attack and decay times a wide variety of sounds can be produced.

For example, if a rapid attack and slow decay is applied to the VCA control, then a percussive sound like a piano results. Applied to the VCF in the low-pass mode, the same envelope contour can produce very bright, metallic sounds, depending on the input waveform.

If the attack period is made long and the decay period short, then applying this to the VCA will produce completely synthetic 'fantasy' sounds similar to those obtained by playing a recording backwards. Applying this type of envelope contour to the VCF can produce sounds similar to those of a brass instrument played staccato.

However, the main use of this type of envelope curve is for the production of percussive sounds such as xylophone, marimba, glockenspiel, bells and gongs, cymbals, and struck or plucked strings such as guitar, banjo, harp, other string instruments played pizzicato, harpsichord, and of course, piano.

2. Attack-sustain-release contour

The attack/decay characteristic previously described is typical of instruments where the sound is initiated by a short pulse of energy (e.g. by striking or plucking a string), after which the sound dies away since there is no further excitation to sustain it. The envelope contour shown in figure 2 is typical of instruments in which a note is sounded and sustained, such as a pipe organ, woodwind instruments, and bowed string instruments. In a pipe organ the note builds up fairly rapidly after a key is depressed as standing wave modes are established in the pipe, and the note is sustained by virtue of the fact that air is continuously blown into the pipe. When the supply of air stops on releasing the key the note terminates more or less rapidly.

The same basic contour applies to woodwind instruments and to string instruments played with a bow, since the note is here again sustained by blowing or bowing. However, with such instruments much greater expression can be obtained by modulation of the

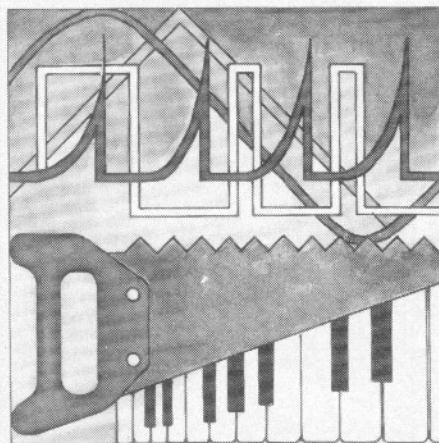

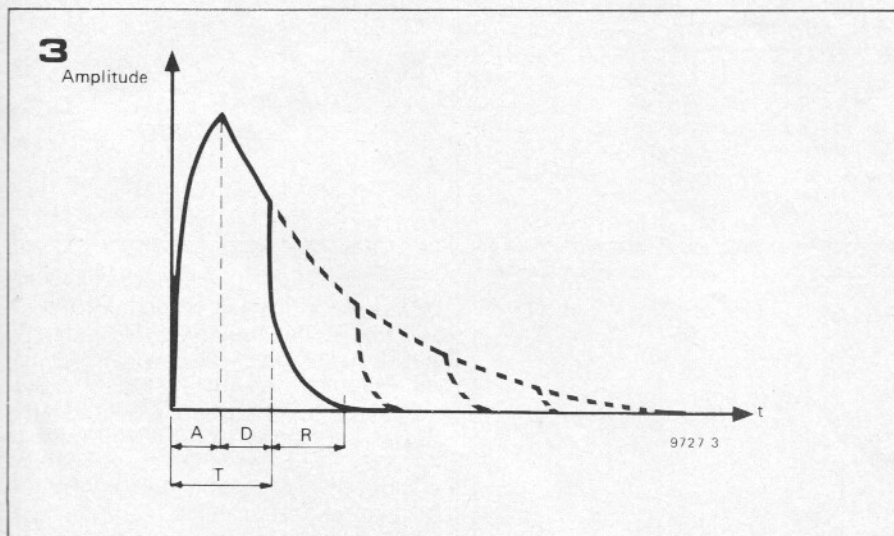
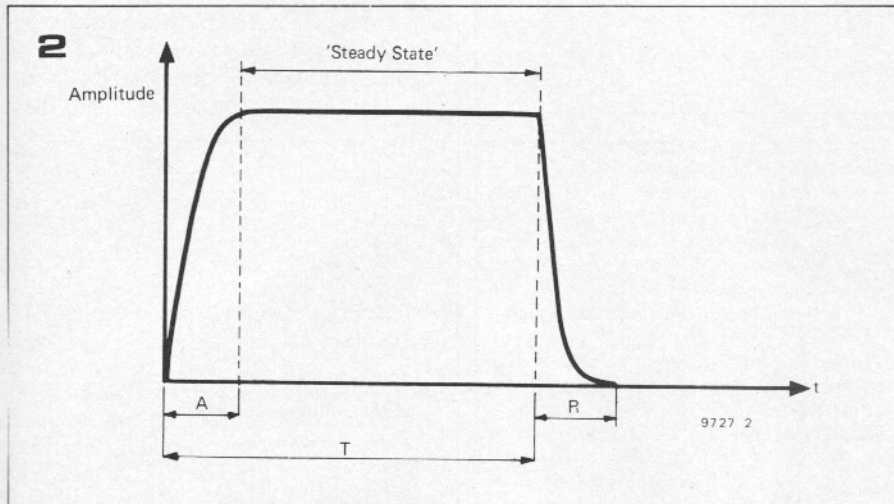
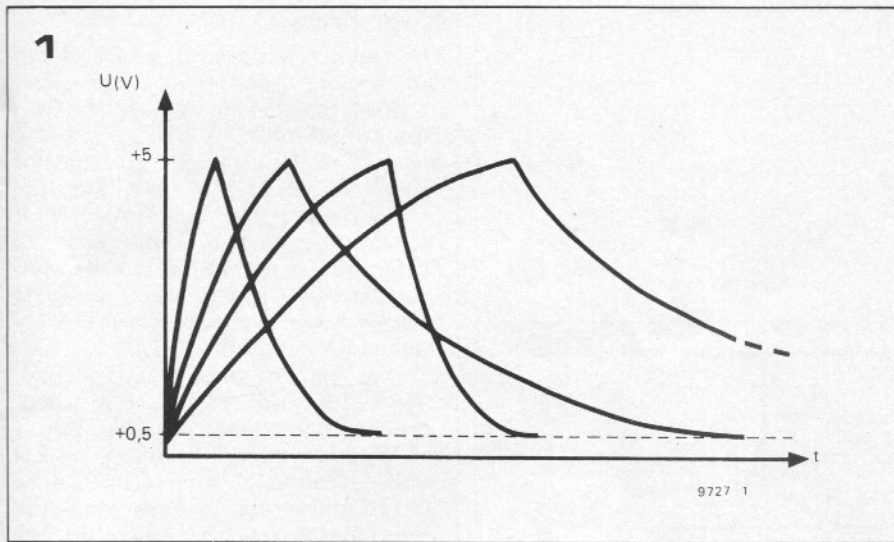

steady-state level, since this is determined by the player, and not by a mechanical blower as is the case with a pipe organ.

With a synthesiser, a degree of expression can be obtained by modulating the VCA using the low-frequency oscillators or noise source.

3. Attack-decay-release contour

A variation on the attack-decay contour is shown in figure 3. Here the slow

Figure 1. The attack-decay envelope contour is the simplest contour found in music.

Figure 2. The attack-sustain-release contour is used to simulate instruments where the note can be sustained at a constant level, such as organ, woodwind, and bowed string instruments.

Figure 3. Instruments such as the piano can be simulated using the attack-decay-release contour. As long as the key remains depressed the decay path is followed, but once the key is released the note is ended more abruptly, following the release contour.

decay is allowed to continue for only a certain time, and the note is then terminated by a more rapid release. The most common example of this type of contour is provided by our old friend, the piano. When a note is sounded and the key remains depressed, then the damper is held off the string and the note decays over a period of a few seconds. If, however, the key is released after playing a note, the felt damper contacts the string and the note terminates after about 500 ms.

4. Attack-decay-sustain-release contour

Most of the examples given so far relate to envelope control of the VCA, since the amplitude contour of a sound is somewhat easier to visualise than its dynamic tone colour behaviour. However, the most complex envelope contour, shown in figure 4, is a good illustration of envelope control of the VCF.

Many brass instruments, such as the trumpet, are characterised by a rapid build-up of harmonics during the attack period of the note, which gives the instrument a very strident sound. Once the note is established, however, the harmonics die away somewhat, and the tone is much more mellow during the steady state period. Finally, during the release period at the end of the note, the note dies away fairly rapidly.

This type of characteristic can be obtained by using the VCF in the low-pass mode and controlling it with an envelope contour similar to that shown in figure 4. As the control voltage rises during the attack period, so the turnover frequency of the VCF increases, passing more harmonics. During the decay period the VCF turnover frequency falls until the steady-state value is reached, and finally, during the release period the VCF turnover frequency drops very rapidly.

Envelope shaper requirements

It is apparent from figure 5 that the envelope contours shown in figures 1 to 3 are merely special cases of the more general attack-decay-sustain-release contour illustrated in figure 4. Any of the four contours can be generated by an envelope shaper having the following four functions:

- variable attack time (A)
- variable decay time (D)
- variable sustain level (S)
- variable release time (R)

These four parameters can be preset manually using the ADSR controls of the envelope shaper. The envelope shaper is controlled by the gate pulse output of the keyboard. When a key is depressed the gate output goes high and this initiates the attack-decay sequence. The output of the envelope shaper then remains at the sustain level until the key is released, when the release period begins.

4

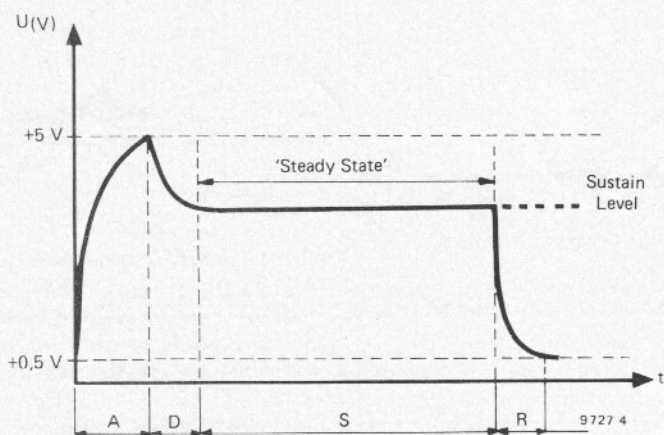

5

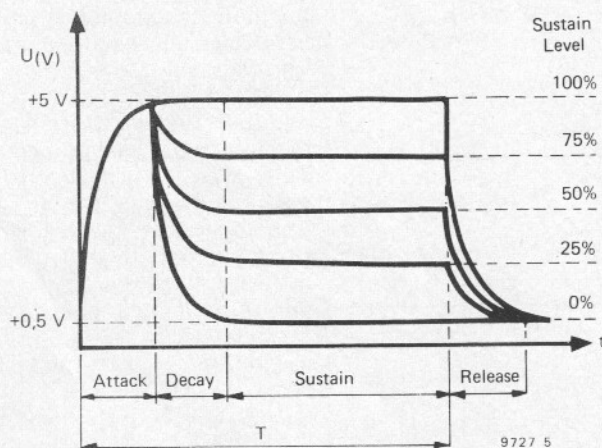

6

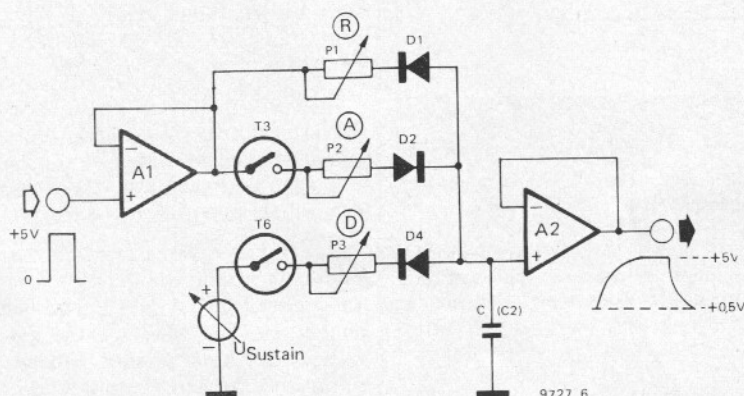

Block diagram

The required exponential attack, decay and release characteristics are easily obtained by charging and discharging a capacitor through resistors, and the sustain level by clamping the capacitor voltage to a preset D.C. level during the sustain period. The basic principle of the envelope shaper is illustrated in figure 6. The gate pulse is fed to a voltage follower A1, and when the gate pulse is high C charges exponentially through P2 and D2 (and T3).

At the end of the Attack period, 'switch' T3 is opened and T6 is closed. Capacitor C now discharges through D4 and P3 (Decay), until the Sustain level is reached. This level is maintained until the gate pulse finishes, either when the key is released or when a preset time has elapsed.

When the gate pulse finishes, the output of A1 goes to zero volts, and C discharges through D1 and P1 (Release). The capacitor cannot discharge fully,

ADSR adjustment ranges:

Attack period (A)	10 ms ... 20 s
Decay period (D)	10 ms ... 20 s
Sustain level (S)	0.5 V ... 5 V
Release period (R)	10 ms ... 20 s

since D1 ceases to conduct once the voltage on C has fallen to about 0.5 V, but this is not important as it merely constitutes a D.C. offset which can be compensated for. The attack, decay and release times may be adjusted by means of P2, P3 and P1.

Complete circuit

The complete circuit, which is shown in figure 7, is, of course, more complicated. The envelope shaper has two modes of operation, ADSR and AD, which are selected by means of S1. With S1 in position 'b' (ADSR) the circuit operates as follows:

When a key is depressed the gate pulse output goes to +5 V. IC1 has a gain slightly greater than unity, so about +6 V appears at its output.

The leading edge of the gate pulse also triggers monostable T1/T2, which pro-

7

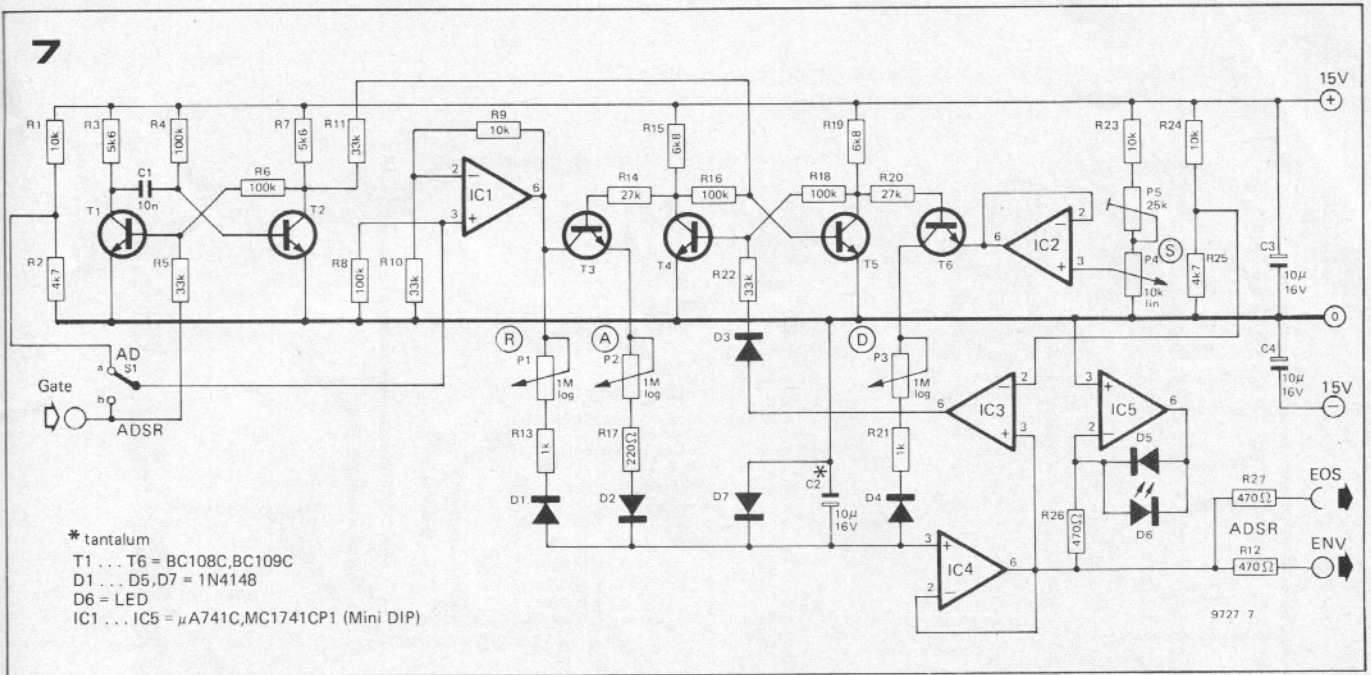

* tantalum
 T1...T6 = BC108C, BC109C
 D1...D5, D7 = 1N4148
 D6 = LED
 IC1...IC5 = μ A741C, MC1741CP1 (Mini DIP)

9727 7

duces a short pulse to set flip-flop T4/T5 (T5 turned on and T4 turned off). The collector voltage of T4 thus rises, turning on T3 and allowing C2 to charge from the output of IC1 through T3, P2, R17 and D2. This is the attack period.

The voltage on C2 is fed to voltage-follower buffer IC4, which is connected to the outputs EOS and ENV and also to the non-inverting input of IC3. This IC functions as a comparator, with its inverting input held at about 4.7 V by R24 and R25. When the voltage on C2, and hence at the output of IC4, exceeds this value, the output of IC3 swings positive, resetting flip-flop T4/T5, turning off T3 and terminating the attack period. T6 is turned on, initiating the decay period when C2 discharges through D4, R21, P3 and T6 into the output of IC2 until the sustain level, set at the output of voltage follower IC2 by P4, is reached.

The output of the envelope shaper then remains at the sustain level until the key is released, when the output of IC1 goes to zero volts and C2 discharges through D1, R13 and P1 (release period).

Diode D7 protects C2 in the event of the output of IC1 going negative for any reason, when the voltage across C2 is clamped to a maximum of -0.7 V.

A LED indicator constructed around IC5 allows visual monitoring of the envelope contour. The brightness of the LED follows the envelope voltage.

Two outputs are provided from the envelope shaper; an external output to a front panel socket (EOS), and an internally wired output (ENV).

The full ADSR envelope contour is, of course, produced only if the key is depressed for a period longer than the attack plus decay time, and if the sustain level is greater than 0%. If the key is released before the sustain level is reached then the release period is initiated prematurely, and either AR or ADR curves may be produced. If the

Figure 4. The attack-decay-sustain-release contour is the most complex envelope shape provided by the Formant envelope shaper. When applied to the VCF it is useful for imitating brass instruments, where the harmonic content of the note rises initially to a large value, then reduces to a lower level during the steady-state part of the note.

Figure 5. By varying the sustain level the envelope contour can be changed from an AD contour at 0% sustain, through various ADSR contours to an ASR contour at 100% sustain. T is the time for which the key remains depressed.

Figure 6. This simplified diagram illustrates the basic principle of the envelope shaper. C charges through D2 and P2 during the attack period. It then discharges through D4 and P3 to the (adjustable) sustain level; finally, it discharges through D1 and P1 during the release period. P1, P2 and P3 can be used to vary the release, attack and decay times.

Figure 7. Complete circuit of the Formant envelope shaper.

sustain level is 0% then only AD or ADR curves may be produced, depending on when the key is released. If the sustain level is 100% then, of course, only AR or ASR curves may be produced, depending on when the key is released, since the decay period is inhibited.

Triggered AD mode

It is sometimes useful to be able to produce AD envelope contours that are unaffected by releasing the key, that is to say, once the key is depressed, a fixed attack-decay sequence is initiated, which is completed whether the key is released or not. This triggered AD contour is obtained by setting S1 to position 'a' and selecting 0% sustain. The input of IC1 is now connected to the junction of R1 and R2, so its output is permanently at about +6 V, irrespective of the gate input.

When a key is depressed, the gate signal triggers the monostable, setting the flip-flop and turning on T3. At the end of the attack period, comparator IC3 resets the flip-flop, turning on T6 and initiating the decay period. C2 will now discharge through D4, R21, P3 and T6 to the 0% level (sustain is set at 0%).

Even if the key is released before this sequence is complete, the release period is inhibited since the output of IC1 is permanently at +6 V, so C2 cannot discharge through D1, R13 and P1.

Construction

There are no special requirements with regard to resistor tolerances in the envelope shaper circuit, and ordinary, good-quality 5% carbon film components are quite adequate; C2 should be a tantalum electrolytic capacitor for low leakage, and C1 the usual polyester or polycarbonate type. Semiconductors should all be from a repu-

8

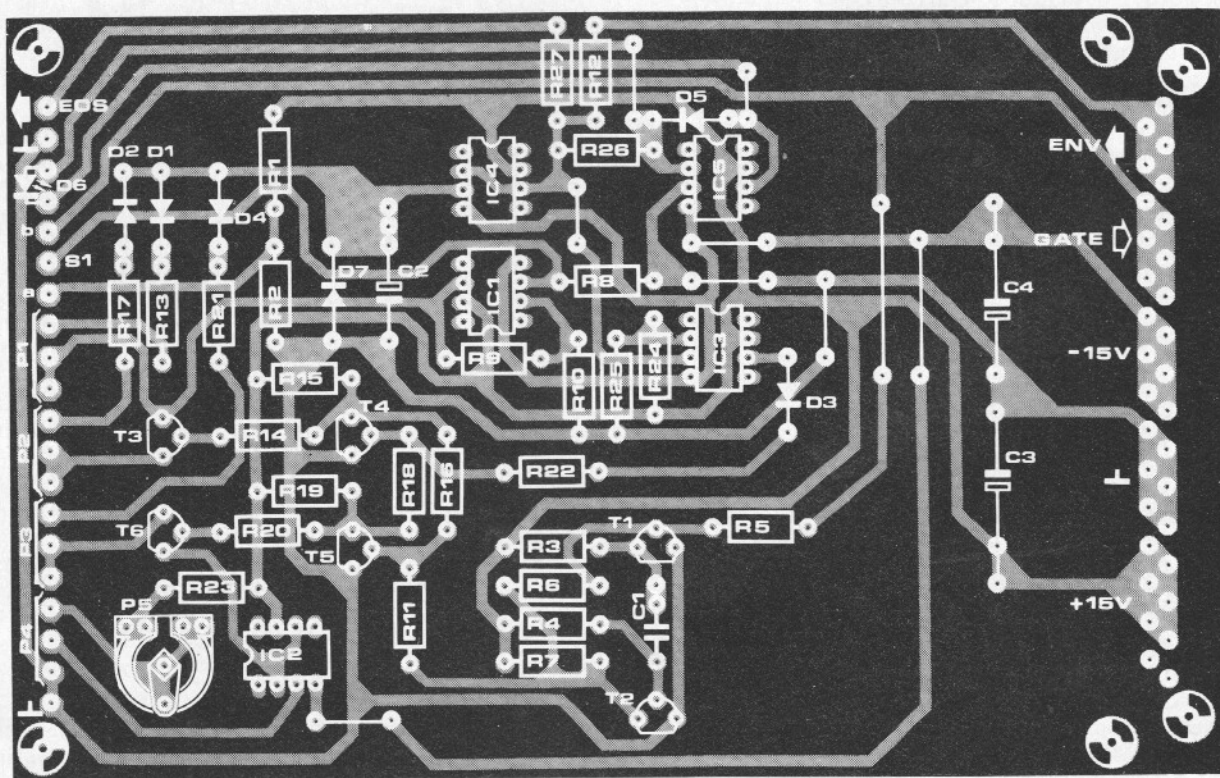
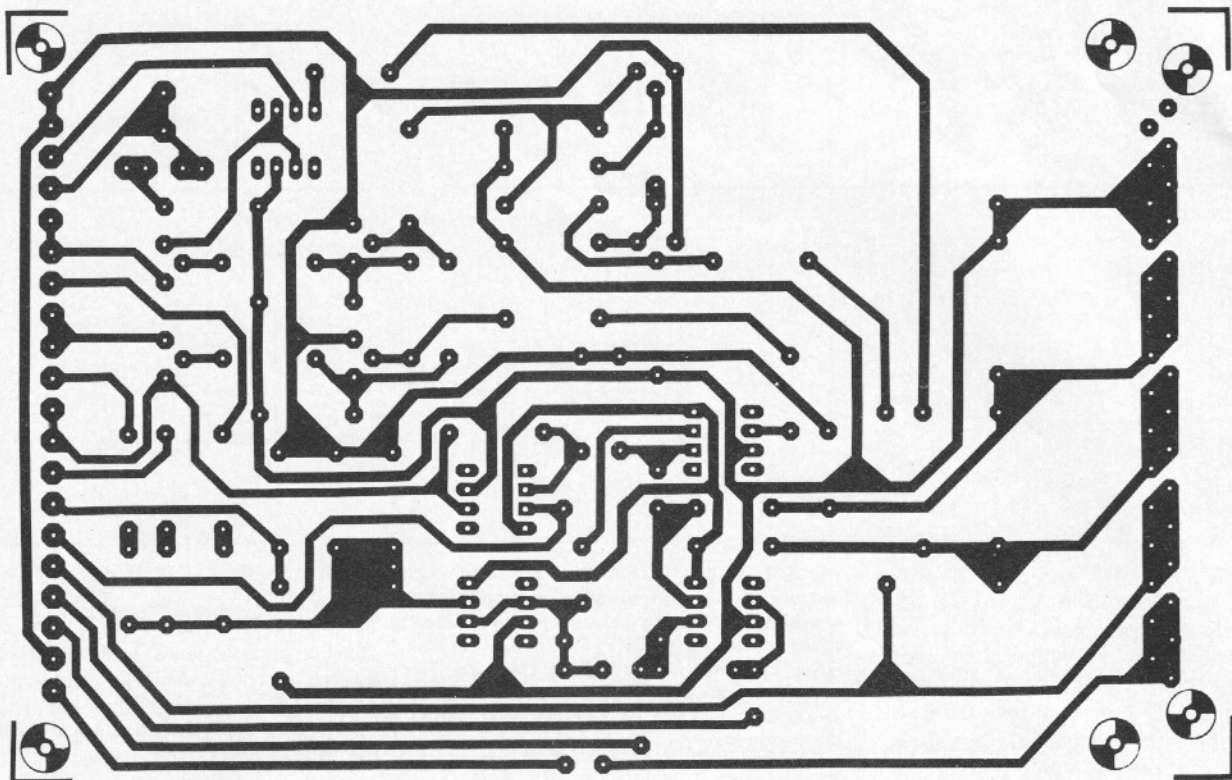

Parts list for figures 7 and 8

Resistors:

R1,R9,R23 = 10 k
 R2,R25 = 4k7
 R3,R7 = 5k6
 R4,R6,R8,R16,R18 = 100 k
 R5,R10,R11,R22 = 33 k
 R12,R26,R27 = 470 Ω
 R13,R21 = 1 k
 R14,R20 = 27 k
 R15,R19 = 6k8
 R17 = 220 Ω

Potentiometers:

P1,P2,P3 = 1 M log.
 P4 = 10 k lin.
 P5 = 25 k preset

Semiconductors:

T1 ... T6 = BC108C, BC109C or
 equivalent
 D1 ... D5,D7 = 1N4148, 1N914
 D6 = LED (TIL 209 or similar)
 IC1 ... IC5 = μ A 741C, MC1741
 CP1 (MINI DIP)

Capacitors:

C1 = 10 n
 C2 = 10 μ /16 V tantalum
 C3,C4 = 10 μ /16 V

Miscellaneous:

31-way Euro connector
 (DIN 41617)
 1 x 3.5 mm jack socket
 4 x 13 ... 15 mm collet knobs
 with pointer

table manufacturer, and it is a good idea to test T3 and T6 for leakage, using the method detailed in part 5.

A printed circuit board and component layout for the envelope shaper are given in figure 8, and a front panel layout is shown in figure 9. Connections to the front panel are fairly simple, the only front panel-mounted components being the four potentiometers for attack time, decay time, release time and sustain level, switch S1, the external output socket and the envelope indicator LED.

Testing and adjustment

To test the envelope shaper a gate pulse must be available from the 'GATE' output of the interface receiver board. The FOS output of the envelope shaper is monitored on an oscilloscope with the Y sensitivity set to about 1 V/div and the timebase set to about 10 ms/div.

For the first test, the sustain level is set to zero. S1 is set to the 'AD' position and the attack and decay potentiometers are set to 'fast'. The release potentiometer has no effect during this test. If a key is depressed at short intervals then a short AD envelope curve will be seen, which rises and falls between about 0.5 V and 5 V. The out-

9

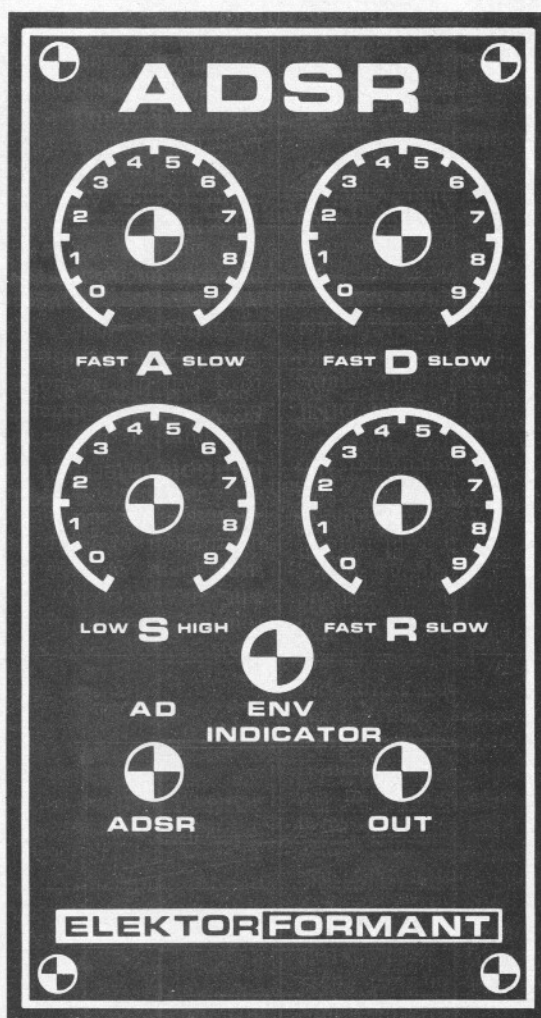



Figure 8. Printed circuit board and component layout for the envelope shaper (EPS 9725-1).

Figure 9. Front panel layout for the envelope shaper module.

put of IC3 can also be monitored, to check that it swings briefly between -15 V and +15 V when the peak of the attack curve is reached.

The only adjustment required to the envelope shaper is to set the 100% sustain level, using P5, to correspond with the voltage on C2 at the end of the attack period. If it is too low, then there will always be a decay, even at 100% sustain level; if it is too high then the calibration of P4 will be inaccurate, since 100% sustain will be reached before maximum rotation of the potentiometer.

To make the adjustment, the sustain level is set to 100% and medium attack and decay times are selected. Preset P5 is then adjusted until there is just no decay after the attack period (i.e. the attack period blends into the sustain level with no dip). The adjustment can be checked by turning P4 slightly to the left, when a slight dip after the peak of the attack period should be noted. As P4 is turned further anticlockwise then the decay down to the sustain level will become greater and greater, until finally, at 0% sustain level, pure AD curves will be produced. The envelope shaper is now ready for use. (to be continued) 

simple function generator

Most commercially available function generators suffer from the distinct disadvantage that they represent a pretty hefty investment for the amateur constructor, who, unlike a service workshop for example, is unlikely to ever make full use of the wide range of facilities offered by a professionally produced instrument. For this reason, the circuit described here, which incorporates a special function generator IC, type XR 2206, was designed to strike the right balance between cost and performance. Although lacking 'top-notch' specifications, it offers a wide range of waveforms, is both simple to build and calibrate, and is extremely easy to operate.

The function generator can switch between sine, square, triangle, sawtooth and rectangular pulse waveforms. It has a linearly calibrated frequency scale which covers a range of 9 Hz to 220 kHz. In addition to a special output stage which ensures a low output impedance, three calibrated output voltage ranges are provided: 0 ... 10 mV, 0 ... 100 mV and 0 ... 1 V (RMS). The circuit can be calibrated without the assistance of an oscilloscope, and the compact design means that it can be easily mounted in a neat case.

The XR 2206

The circuit utilises the purpose-built IC function generator, type XR 2206 (Exar), the pin configuration and internal block diagram of which are shown in figure 1. The heart of this IC is the VCO (which in fact is a current controlled oscillator, CCO, though the manufacturer's data calls it a VCO). The frequency of the oscillator is determined by the external capacitor and resistor, C_{ext} and R_{ext} . A control current, I_f , is switched via integrated current switches to one of the two current outputs (pin 7 or 8) of the IC, depending on the logic level of the selector input (pin 9), thus providing the possibility of frequency shift keying (FSK).

The VCO output is buffered by an integrated transistor, the collector of which is accessible at the synchronisation output, pin 11. This output provides a rectangular pulse waveform. In

A function generator is a versatile and extremely useful device, which provides the constructor with a simple and efficient means of testing his home-built projects. It should therefore be a virtually indispensable part of any hobbyist's basic equipment.

addition the VCO signal provides the basis for the signal generation carried out in the multiplier and sine converter section. Pins 13 ... 16 allow adjustment of sine purity (distortion factor) and symmetry. The DC level at the signal output can be adjusted via pin 3.

The sine, triangle and sawtooth waveforms are buffered via a voltage follower, and are brought out at the low impedance output, pin 2.

The amplitude of the sine/triangle output can be varied linearly by a control voltage at AM input pin 1 of the IC. This makes amplitude modulation of the oscillator signal possible.

The voltage between the current connection pins 7 and 8 is stabilised to 3 V (typically) within the IC. As this reference voltage exhibits only a very small temperature coefficient ($6 \times 10^{-5} \text{ V}/^\circ\text{C}$), the temperature stability of the oscillator frequency is also very good.

The control current I_f may vary between 1 μA and 3 mA; however, optimum temperature stability is obtained in the range between 15 μA and 750 μA . The frequency of the VCO is determined by this current I_f and the value of the external capacitor C_{ext} , the control current being adjusted by means of a resistance R_f between pins 7 or 8 and earth. The equation for the frequency is as follows:

$$f = \frac{I_f}{3 C_{ext}} \quad (\text{Hz, A, F})$$

$$f = \frac{1}{R_{ext} C_{ext}}$$

As a result of the above function the graph of frequency versus value of R_{ext} is not linear but hyperbolic (see figure 2, curve a). It would be possible to obtain an approximation to a linear curve by using an anti-logarithmic potentiometer. However, by means of a little ingenuity it is possible to vary the control current linearly, so that the resultant frequency scale will also be linear (see figure 2, curve b).

This is done as follows. A constant voltage of 3 V is present at pin 7 of the IC. The current which flows from this pin to earth is directly proportional to the

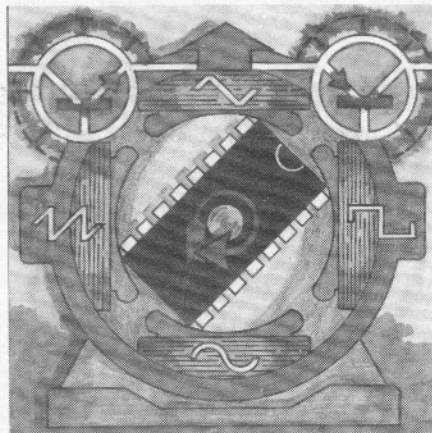

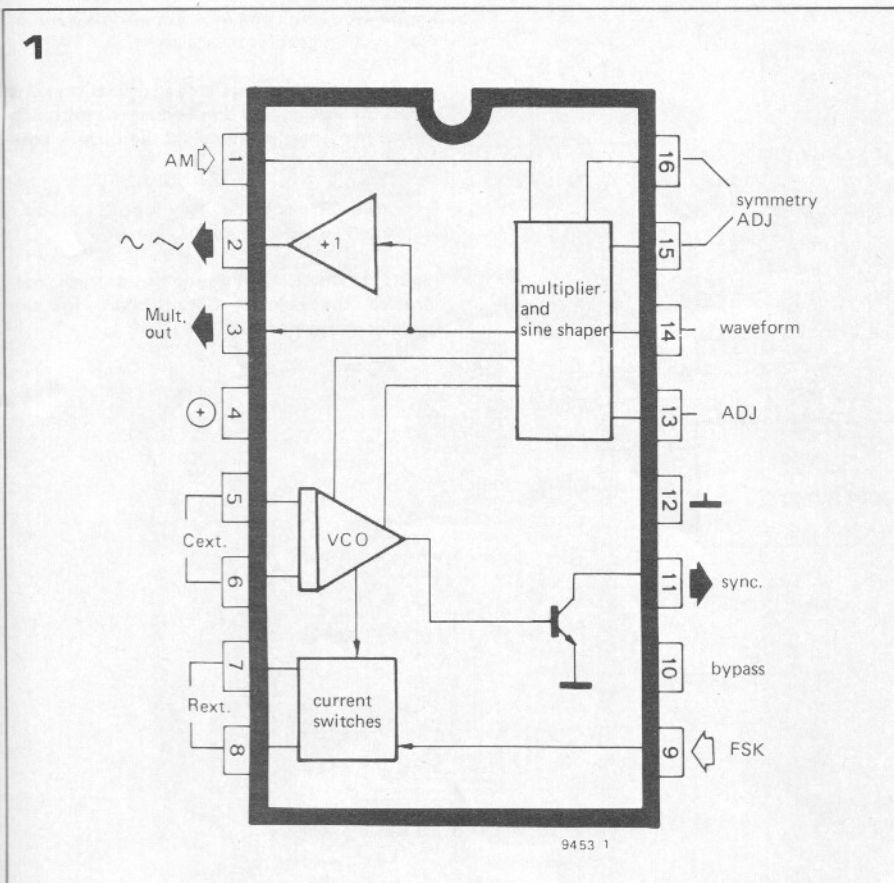

output frequency, so that a linear change in this current will, of course, cause a linear change in the frequency. In figure 3 this current change is effected by means of the voltage divider R4, P1, P6 and R7. The component values of this divider are so chosen that the voltage U_f at the wiper of P1 may vary between 0.3 and 2.8 V. This voltage determines the voltage drop across $R_5 (= 3 V - U_f)$ and, by virtue of Ohm's law, the frequency-determining current I_f which flows through this resistor. Since there is a linear relationship between voltage drop and current, a linearly calibrated scale for the adjustment of frequency can be obtained using a linear potentiometer:

$$I_f = \frac{3 V - U_f}{R_5}, \text{ so}$$

$$f = \frac{3 V - U_f}{3 \times R_5 \times C_{ext}} \text{ (Hz, V, } \Omega, F)$$

When switch S2 is closed, and assuming that $R_5 = R_6$, then the control current is doubled, thereby doubling the frequency of the VCO. The adjustment range of P1 enables the frequency to be varied over slightly more than a decade, i.e. from 9 Hz ... 110 Hz for example. Fine adjustment is achieved by means of P6.

The generator

The complete circuit diagram of the generator is shown in figure 4. Pin 2 is the output for sine, triangle and sawtooth waveforms, whilst squarewave and rectangular pulse waveforms are available at pin 11. C1 to C4 are the frequency determining external capacitors (C_{ext}). Switching between frequency ranges is effected by means of S1. C5, C6 and C12 are decoupling capacitors.

The voltage divider R1/R2 halves the supply voltage, and via pin 3 sets the DC voltage level of the IC. As a result the DC voltage at pin 2 is also $\frac{U_b}{2} = 6 V$.

The amplitude of the output signal may be varied by means of P2 and P3. The adjustment is carried out separately for sinewave (P2) and triangle/sawtooth (P3) in order that the peak-peak value of all three voltages be the same; S3a allows for switching between P2 and P3. The symmetry of the triangle and sine waveforms can be adjusted by means of potentiometer P4, whilst the distortion factor of the sinc signal can be varied by means of P5. Switching between sine and triangle waveforms is achieved by S3b.

When switch S4 is closed a sawtooth signal is present at output A. The integrated current source will then switch between pin 7 and 8 at a rate equal to the frequency of the rectangular pulse signal at output B, thus providing an 'automatic' frequency shift keying. The slope of the trailing edge is determined by the value of R8, which should be not lower than 1 k.

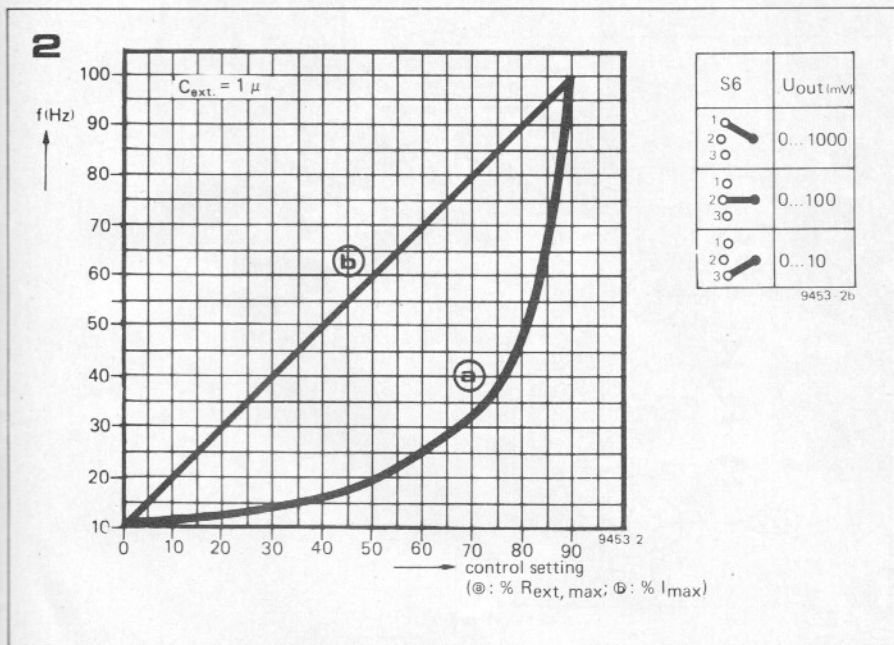
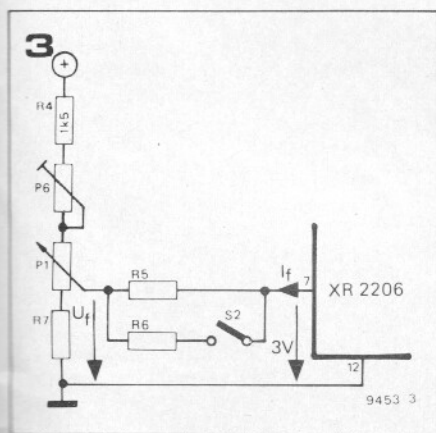

Figure 1. Internal block diagram of the function generator IC, XR 2206.

Figure 2. The principal feature of this function generator is the linear frequency scale, which considerably improves ease of operation.

Figure 3. This partial circuit configuration, with the XR 2206, produces an almost linearly calibrated frequency scale.



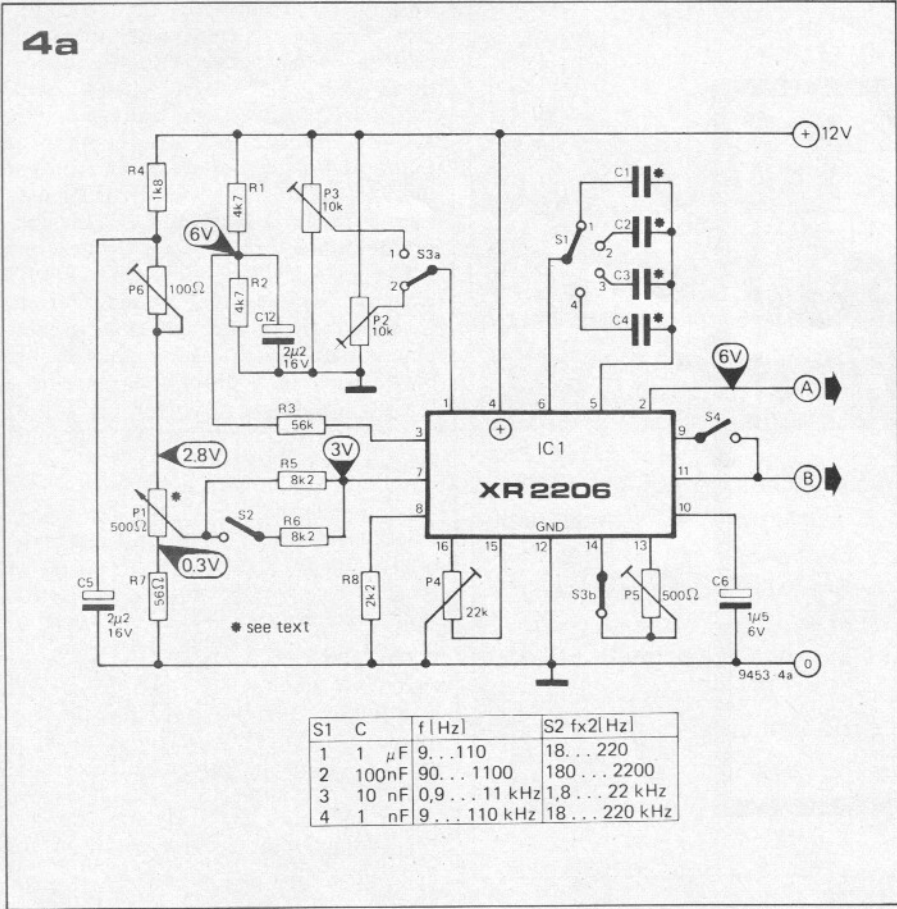
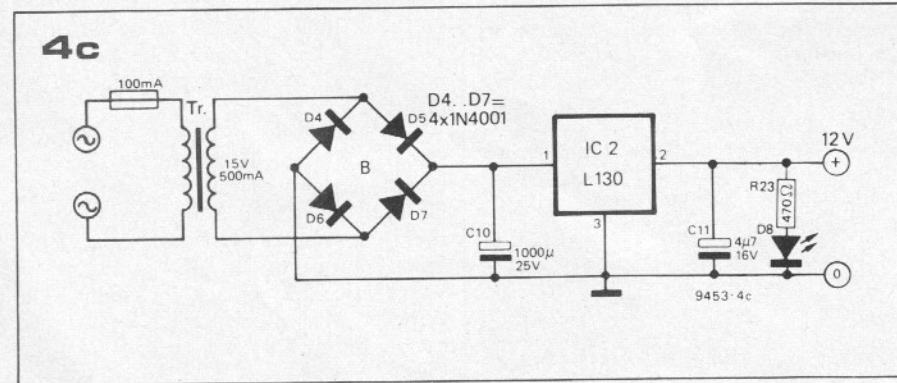
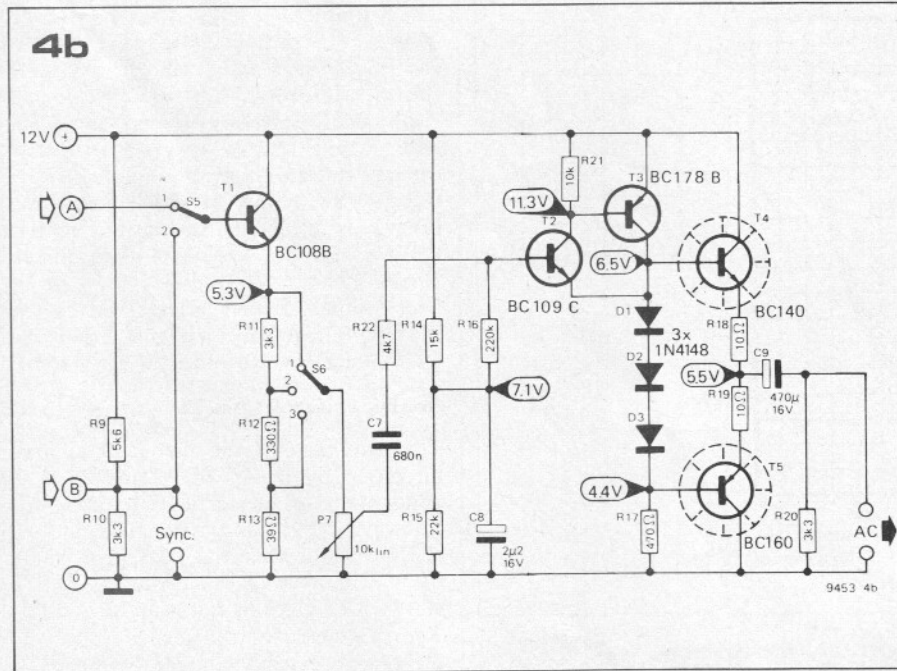

Figure 4a. The complete circuit diagram of the function generator section.

Figure 4b. The output stage ensures that the generator has a low impedance output and allows precise adjustment of the output voltage.

Figure 4c. The power supply is built round an integrated voltage regulator.

Figure 5. Component layout and track pattern of the printed circuit board for the function generator (EPS 9453).



5

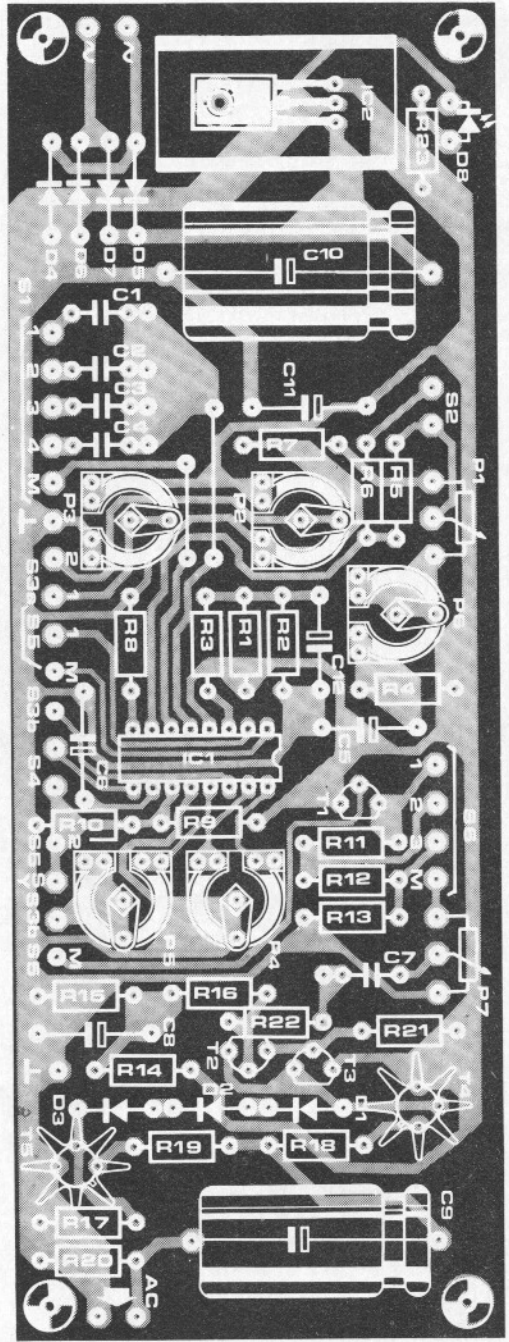
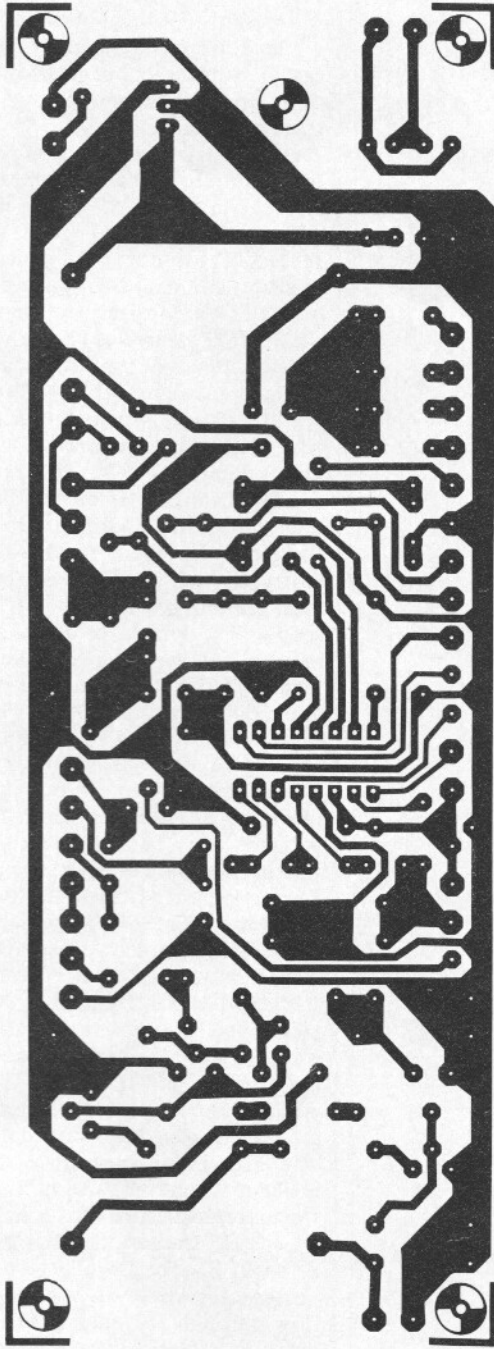

Parts list

Resistors:

R1,R2,R22 = 4k7
 R3 = 56 k
 R4 = 1k8
 R5,R6 = 8k2
 R7 = 56 Ω
 R8 = 2k2
 R9 = 5k6
 R10,R11,R20 = 3k3
 R12 = 330 Ω
 R13 = 39 Ω
 R14 = 15 k
 R15 = 22 k
 R16 = 220 k
 R17,R23 = 470 Ω
 R18,R19 = 10 Ω
 R21 = 10 k

Potentiometers:

P1 = 500 Ω wirewound
 P2,P3 = 10 k preset
 P4 = 22 k preset
 P5 = 500 Ω preset
 P6 = 100 Ω preset
 P7 = 10 k lin

Capacitors:

C1 = 1 μ
 C2 = 100 n
 C3 = 10 n
 C4 = 1 n
 C5,C8,C12 = 2 μ 2/16 V tantalum
 C6 = 1 μ 5/6 V tantalum
 C7 = 680 n
 C9 = 470 μ /16 V
 C10 = 1000 μ /25 V
 C11 = 4 μ 7/16 V

Semiconductors:

IC1 = XR 2206
 IC2 = L 130
 T1 = BC 108 (107, 109, 546, 547, 548)B
 T2 = BC 109 (107, 108, 546, 547, 548, 549)C
 T3 = BC 178 (177, 179, 556, 557, 558)B
 T4 = BC 140
 T5 = BC 160
 D1 ... D3 = 1N4148
 D4 ... D7 = 1N4001
 D8 = LED

Switches:

S1 = multiposition; 1 pole 4 way
 S2 = SPST
 D3a,S3b,S4,S5 = multiposition;
 4 pole 5 way, or 3 switches;
 DPDT, SPDT, SPST
 S6 = multiposition; single pole
 3 way

Miscellaneous:

Tr = transformer 15 V/500 mA
 100 mA fuse with holder
 2 heat sinks, type TO 5
 (for T4/T5)
 4 sockets, 4 mm diameter

6

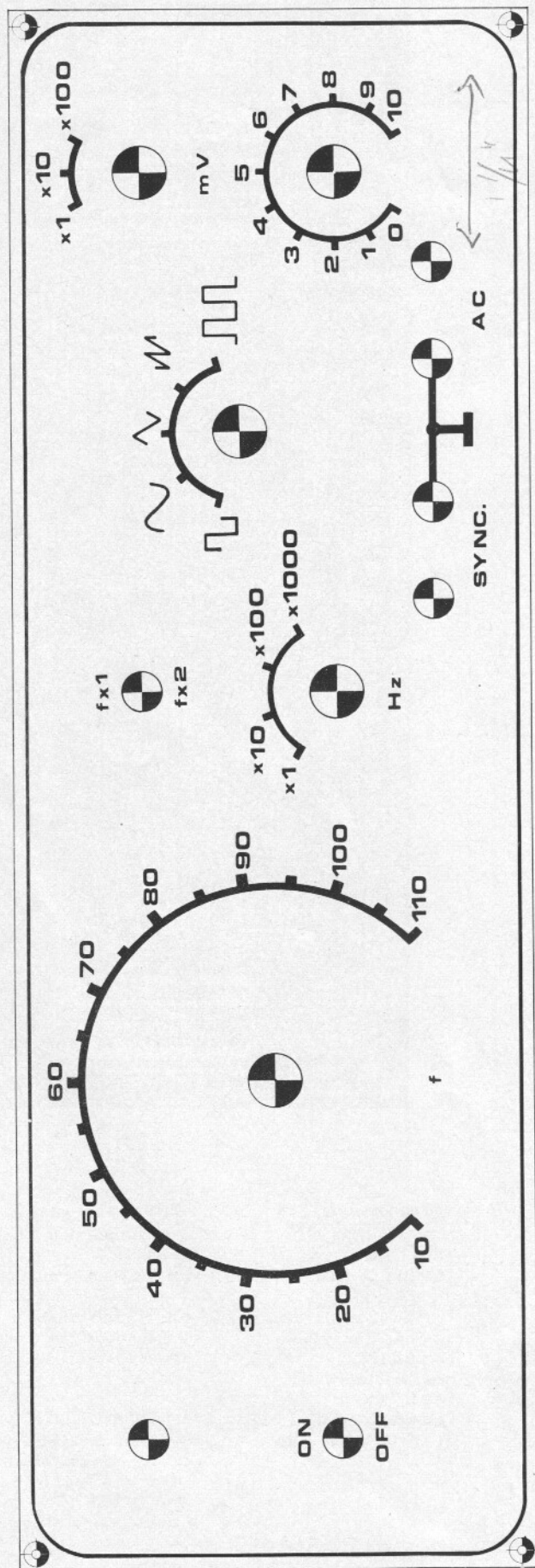

The output stage

A prerequisite of a good signal generator is a low output impedance and a precise, easily adjustable output voltage. Both these conditions are met by the output stage shown in figure 4b.

The sine, triangle and sawtooth signals from output A of the generator stage are fed via switch S5 to the base of T1. The squarewave and pulse signals are present at output B of the generator, this output being the collector terminal of a buffer transistor contained within the IC (see figure 1). R9 is the collector resistor of this transistor, and at the same time, together with R10, forms a voltage divider which limits the amplitude of the squarewave signals to approximately 4.5 V. This ensures that the sync. output is both TTL compatible and short-circuit proof and may therefore be used to drive TTL circuitry, as well as to provide synchronisation and trigger signals for an oscilloscope. T1, which is connected as an emitter follower, buffers the relatively high impedance outputs of the generator (600 Ω and 2000 Ω). The division ratio of the voltage divider R11...R13 are 1, 10 and 100, thus dividing the output amplitude into three switchable (by means of S6) decade ranges. The output voltage can be varied continuously within these ranges by means of P7.

The actual output stage itself consists of transistors T2 to T5, which together form a DC coupled voltage follower. T2 and T3 form an emitter-follower consisting of a complementary Darlington pair, which ensures that the output stage has a high input impedance and that the output transistors T4 and T5, which are also a complementary pair, are driven from a low impedance source. The high input impedance reduces the load on P7 and allows a non-electrolytic capacitor to be used for C7. Via diodes D1...D3 transistors T4 and T5 receive a base bias voltage which causes a quiescent current of approx. 30 mA to flow through the emitter resistors. This measure effectively reduces the distortion of the output stage. C9 AC couples the output signal. The impedance of the AC output is approximately 5 Ω , which means that it can be connected direct to a loudspeaker. The AC output is also short-circuit proof.

The power supply

The supply (see figure 4c) is quite straightforward, being built round an IC regulator which produces a stable 12 V output. Since the supply, generator and output stage are all mounted on the same board, the only external connection required is the mains transformer (approx. 15 V/0.5 A). LED D8 provides on/off indication.

Printed circuit board and front panel

The entire generator is mounted on a single printed circuit board (see fig-

7

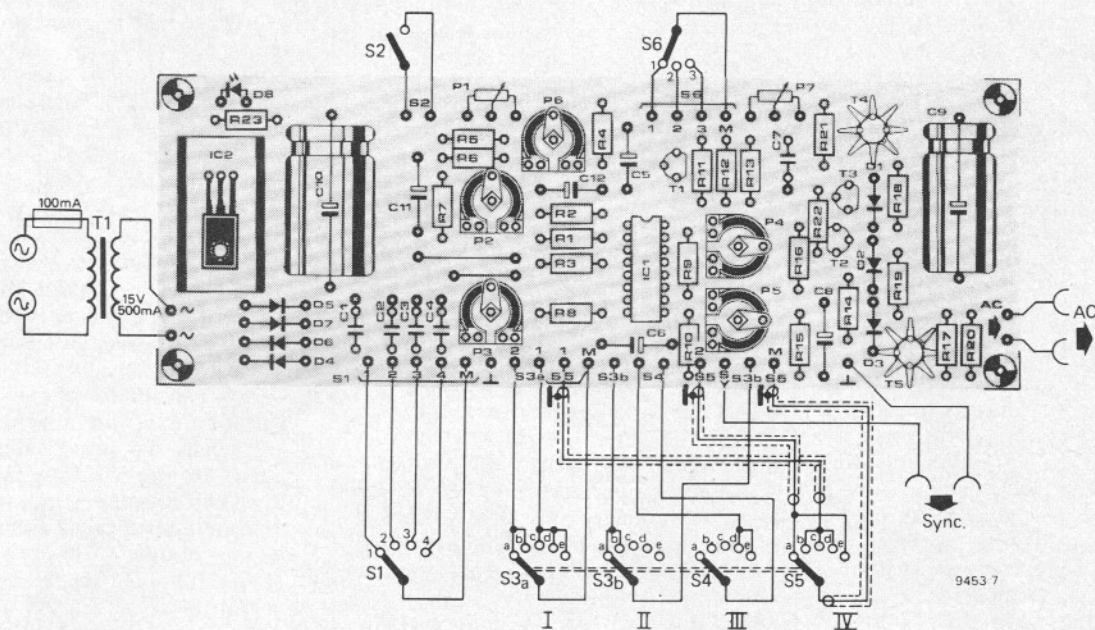

9453 7

8

AC	S3a	S3b	S4	S5
	X	X		1- 2-
	1- 2-			1- 2-
	1- 2-			1- 2-
	1- 2-			1- 2-
	X	X		1- 2-

X = don't care

9453 8

9

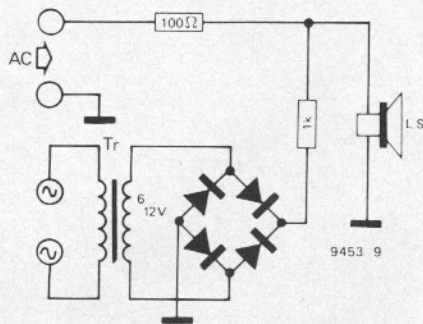

9453 9

ure 5), thus considerably facilitating construction. Figure 6 shows a suggested design for the front panel.

The individual controls and sockets are arranged in functional groups for ease of operation. The power indicator LED, D8, is mounted above the on/off switch. To the right of them is potentiometer P1 which controls the signal frequency. The large easily-read scale allows fine frequency adjustment. The desired frequency range can be selected using the 'Hz' switch (x 1, x 10, x 100, x 1000); i.e. 10 ... 110 Hz, 100 Hz ... 1.1 kHz, 1 kHz ... 11 kHz, 10 kHz ... 110 kHz. Each of these frequencies can be doubled using the f x 2 switch, so that eight frequency ranges are available in

Figure 6. The ergonomically designed front panel facilitates operation of the function generator.

Figure 7. Wiring diagram for the sockets, switches and potentiometers situated on the front panel.

Figure 8. The single multiposition switch used to select the desired waveform can be replaced by three separate switches (S3a, S3b, S4 and S5).

Figure 9. Accurate frequency calibration can be achieved by using this simple supplementary circuit.

all. The selector switch for the various waveforms is situated to the right of the frequency controls.

The output voltage is continuously variable between 0 ... 10 mV, 0 ... 100 mV, and 0 ... 1000 mV, the appropriate range being selected by means of the 'mV' switch (x 1, x 10 and x 100). The output signal is taken from the 'AC' terminals, and the synchronisation signal from the 'sync' terminals.

Wiring and construction

To further facilitate construction of the function generator a wiring diagram (see figure 7) is provided. In particular, the wiring of the selector switch for the

various waveforms seems fairly complicated at first sight. A 4-pole, 5-way switch is required, which must first be wired 'internally' and then soldered to the appropriate connections on the printed circuit board (see figure 7). It is recommended that screened wire be used for switch S5, since this will prevent crosstalk from the squarewave signal on these leads. The wiring for switches S1, S2 and S6, as well as that for the AC and sync outputs, should present no special problems.

Components

A wirewound potentiometer is recommended for P1, since this type generally has a superior linearity to that of carbon potentiometers. Of course the use of a 10 turn potentiometer with slow motion drive, which would provide extremely accurate adjustment of frequency, is also possible; however this would naturally involve somewhat more expense. Only close tolerance capacitors (MKM) should be used for C1 ... C4.

It is also worth mentioning that it is, of course, possible to replace the multi-position switch used to select the desired waveform by three separate switches (see figure 8). This solution does complicate the operating procedure slightly, and whether it proves cheaper or not will depend on the type of switch which is used.

Calibration

After the components have been soldered onto the circuit board and the external switches and potentiometers have been wired up, the entire construction should be carefully checked. Once this has been done power can be applied and the on load supply voltage measured. This should not vary more than 10% from 12 V.

Amplitude calibration

- First of all switch S6 should be set to position 1 (x 100) and potentiometer P7 turned fully clockwise (maximum amplitude).
- Select a sinewave signal with a frequency of approx. 1 kHz.
- Set P2 for minimum amplitude, i.e. turn the wiper to earth.
- Set P4 and P5 to their mid-position.
- Connect a universal multimeter with an AC voltage range of 2 V RMS to the AC output of the generator, and adjust P2 for an output of either 1 V or 2 V RMS.

The above step requires a little clarification. The advantage of selecting the higher output voltage of 2 V RMS is offset by a resultant deterioration in the quality of the waveform at high frequencies (above roughly 50 kHz). Thus, in order to obtain a reasonably pure waveform for frequencies up to approx. 200 kHz, it is recommended that the output voltage be set to 1 V.

To achieve the low distortion factor of typ. 0.5% specified in the IC's data sheet, further calibration using a distortion factor meter is required. In this respect it should be mentioned that, in spite of the carefully designed board layout and the use of screened leads to and from switch S5, there is the likelihood of crosstalk (largely within the IC itself) between the squarewave- and sinewave outputs. At increased frequencies this results in pulse spikes being superimposed upon the sinewave signal. For applications which require a minimal distortion factor the simplest solution to this problem is to short out the squarewave output, thereby removing the source of the distortion.

- Coarse adjustment of the output signal for distortion is achieved using P5, whilst P4 provides fine adjustment. If no distortion factor meter is available, then setting P4 and P5 to their mid-position should give satisfactory results.
- The amplitude of the triangle and sawtooth signals can be adjusted by means of P3. Switch to the triangle waveform, and adjust P3 until the multimeter reads approx. 0.8 V.

Of course the adjustment procedure can also be carried out using an oscilloscope:

sin: by means of P2 set the amplitude to 2.82 V_{pp} (the equivalent of 1 V RMS) or 5.65 V_{pp} (2 V RMS).

triangle: by means of P3 set to 2.82 V_{pp} or 5.65 V_{pp}.

Frequency calibration

There are basically two methods of calibrating the function generator frequency scale.

The first is to use a frequency counter connected to the synchronisation output, set P1 to 100 Hz, and by means of P6 the frequency can be adjusted to correspond with the scale reading.

The second method is to use the circuit of figure 9. The AC voltage of roughly 6 ... 12 V supplied by the bell transformer is rectified and fed via a 1 k resistor to a loudspeaker. This results in a pulsed DC voltage which has a frequency of 100 Hz, and which is clearly audible, being applied to the loudspeaker. In addition the loudspeaker is fed via a 100 ohm resistor with a 100 Hz sinewave signal taken from the function generator (AC output). Since these two signals add, a beat note is produced as they drift in and out of phase. By means of P6 the frequency of the function generator can then be adjusted until zero beat occurs. In only a very few cases will an absolute zero beat be produced, since both the mains- and the generator frequency are subject to periodic fluctuations. For this reason it is sufficient to reach a low beat frequency of under 5 Hz.

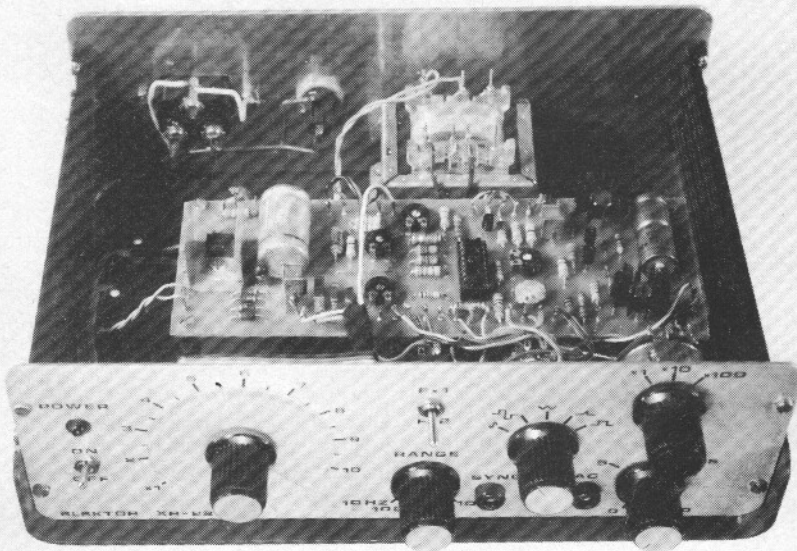

market

Security lock uses identity cards

An extra feature to their electronic digital door lock is introduced by A.R.C. Europe Ltd - an integral card or key reader unit.

In its basic form the lock will operate an electric door strike if the correct four figure code is entered on the recessed keyboard. Arrangements are included for secret alarm signals, entry of incorrect codes, changing of codes at will and so on.

With this new model the user has to first push a personal card or key into a slot in the lock and then enter a code which corresponds to that on the card or key. The code is different for each individual and has to be memorised - it could for example be the figures of an important date.

Cards are plastic and are coded magnetically - like bank or cash cards - and keys, about car key size, are of nylon with codes cut as notches. For extra security, however, the code in the card or key is not the same as the one entered. It is itself de-coded by an electronic matrix before comparison with the entered code is made. Matrix boards are plug-in units, so changing them means that from time to time people's memorised codes can be altered without exchanging keys and vice versa.

As on the basic model to allow for operator errors the lock can be set to accept one or several incorrect codes before an alarm sounds. Even when a correct code is entered the door strike is not operated until the card or key is removed from the lock, to prevent its being forgotten. Electronic controls for the locks are all on the inside wall. If an intruder were to wrench the whole lock from the wall the door would remain shut. All locks are independently installed, just plugging into a convenient power socket. No central electronic processor is required. Price, depending on specification is from £495 plus VAT.

*ARC Europa Ltd.
Shakespeare Industrial Estate
Watford
Hertfordshire WD2 5HD
England*

(620 M)

Timer-counter to 35 MHz

New from Gould Advance Ltd., the TC 320 is a rugged, 5-digit timer-counter offering frequency measurement up to 35 MHz. Extensive use of low-power C-MOS and Schottky circuitry, plus thick-film resistor networks and an openplan component arrangement, gives high reliability, easy access for maintenance and low cost of ownership.

Facilities offered by the TC 320 include frequency, single-period, multiple-period and ratio measurement, together with counting and totalising. Frequency measurements up to at least 35 MHz can be easily made with the clear, 7-segment Beckman-type display. The single- or multiple-period facilities can be selected for lower-frequency measurements, and the count mode totalises regular or random events up to a 35 MHz rate. The high-impedance 10 mV input is enhanced by slope selection facilities and a 'disciplined' trigger function; the display indicates zero if a signal is insufficient for correct operation of the amplifier. Input facilities include automatic gain control, with sensitivity automatically adjusted to give optimum triggering.

The instrument is housed in a rugged case measuring 88 mm high x 258 mm deep x 280 mm wide, and weighs 2.27 kg. A multi-positioned carrying handle allows the instrument to stand at varying angles.

A battery-powered option is available, using five rechargeable nickel-cadmium cells to give 8 hours' operation. The batteries are trickle-charged during normal AC operation.

A temperature-controlled crystal option is also available, increasing the crystal accuracy from one part in 10^6 to one part in 10^7 and the temperature stability from one part in 10^5 ($0-35^\circ\text{C}$) to two parts in 10^6 ($0-50^\circ\text{C}$).

*Gould Advance Limited
Roebuck Road
Hainault, Essex
England*

(618 M)

Silicon photovoltaic cells

Recently introduced by NSL is a new family of Silicon photovoltaic cells having not only good stability and high efficiency but also excellent short circuit current linearity over wide ranges of illumination.

Being fully compatible with simple transistor amplifiers and

eminently suitable for both power generation and light sensing applications particularly at low light levels, this family of cells also feature low leakage currents of $10 \mu\text{A}$ maximum when reverse biased by only 1.5 volts and fast response rates of typically $8 \mu\text{s}$. Although these Silicon cells are generally of N on P construction, reverse polarity PN cells can be provided with, in each case, a choice of low capacitance high speed 800 material, or alternatively 700 type material giving higher open circuit voltages.

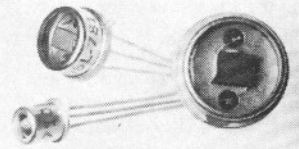

Available in TO18, TO5 and $\frac{1}{2}$ " diameter hermetically sealed packages, both the 700 and 800 series devices will operate over a temperature range of -60°C to $+125^\circ\text{C}$.

*National Semiconductors Ltd.
Stamford House
Stamford New Road, Altrincham
Cheshire, WA 141 DR
England*

(619 M)

High-voltage fast-switching power transistors

RCA Solid State-Europe has launched a new range of high-voltage fast-switching power transistors designed for applications such as switch-mode power supplies and motor control from rectified mains supplies. The devices cover a range of collector currents from 3 A to 15 A, have fall times of 300-800 ns, can sustain collector-emitter voltages up to 450 V, and will operate at up to 30 kHz.

*RCA Limited/Solid State-Europe
Sunbury-on-Thames
Middlesex, England*

(627 M)

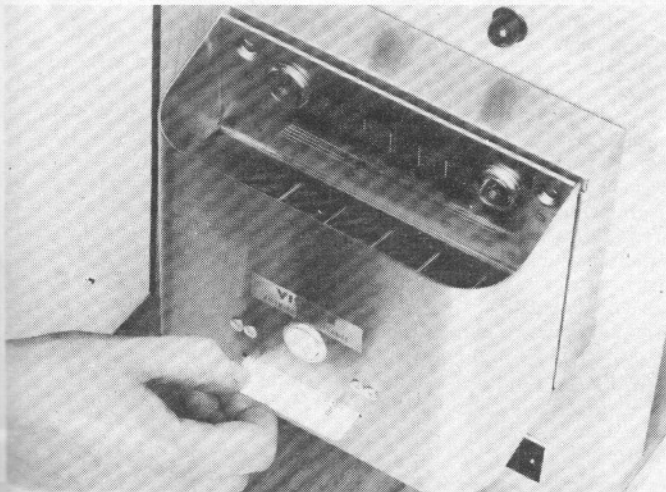
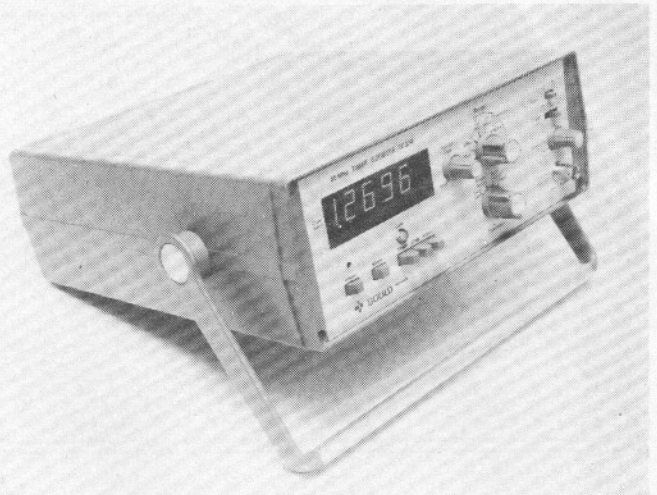

market

Precision low power op-amps

Precision Monolithics have introduced two new precision low power op-amps which are pin-for-pin improved replacements for the popular LM 108/308 series. OP-08 is externally compensated, while OP-12 is internally compensated allowing replacement of 108 type and the 30 pF capacitor. Since elimination of this capacitor is extremely important in hybrid applications, OP-12 is offered in both packaged and chip versions. Major improvements over the LM 108A/308A include three times lower offset voltage drift. The total worst case input offset voltage over -55°C to $+125^{\circ}\text{C}$ is only $350\ \mu\text{V}$. In addition, the OP-08 and OP-12 can drive a $2\ \text{k}\Omega$ load which is 5 times the current capability of the 108A. This excellent performance is achieved by applying Precision Monolithics' ion implanted super-beta process and on-chip zener trimming capabilities.

Bourns (Trimpot) Limited
Hodford House,
17/27 High Street, Hounslow,
Middlesex TW3 1TE
England

(614 M)

Temperature operated switch

The Thermotrigger solid state temperature operated switch, suitable for operation in temperature ranges between 50°C and 80°C , is now available from Lee Green Precision Industries Limited. This device is made from vanadium pentoxide, the resistance of which changes abruptly from high values at low tempera-

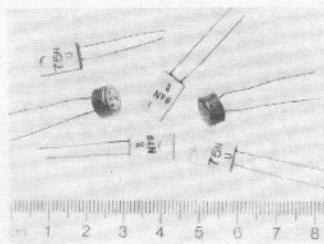

ture to low value at high temperature. The temperature coefficient of resistance changes: in the pre-transition region it is about -5% , in the transition region -8% , and in the post-transition region -20% .

The Thermotrigger is especially suitable for many temperature control applications, such as temperature control in electronic equipment, water temperature control, fusing circuits, battery overcharge prevention etc. One especially interesting application is in the control of water cooling systems for petrol engines to achieve low fuel consumption. As this device is solid state, there are no mechanical contacts and therefore no problems associated with bounce, arcing and switching transients. Circuitry is simplified.

Lee Green Precision Industries Limited
Grotes Place, Blackheath
LONDON SE3 0RA
England

(613 M)

Coaxial connectors

A new range of low-loss $50\ \Omega$ subminiature coaxial cable plugs and jacks which combine the speed and ease of assembly of push fit connectors with the firm retention characteristics of screw and bayonet types, is announced by Suhner Electronics Limited. Designated QL, the connectors were originally developed for the UK Atomic Energy Authority, and have been tested and approved by CERN in Switzerland. Nevertheless many other applications exist, particularly in the instrumentation and communications fields. Suitable for frequencies up to $1500\ \text{MHz}$ and for cables with a dielectric diameter of $1.5\ \text{mm}$ or less, QL connectors employ an unusual quick latch mechanism whereby three independent beryllium copper springs on the plug sleeve locate into a ring groove inside the jack socket. Disconnection is effected simply by pulling on the plug sleeve, but tension on the cable cannot disengage the connector.

Since no twisting action is involved, these connectors are particularly suitable for areas where access is restricted, as well as for equipment with high packing densities. Moreover when rigid copper tube cable is used, it is even possible to insert a QL plug into its socket from a distance of about 4 inches by pushing on the cable, thus facilitating installation through instrument panels.

Whereas most coax connectors are tested to only 500 mating cycles, even for military specifications, the Suhner QL range is guaranteed to 20,000 cycles due to the use of tempered beryllium copper and beryllium bronze latch springs and contacts.

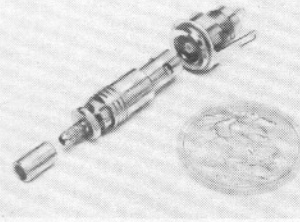

The absence of slots in the connector body results in a surface transfer impedance at $500\ \text{MHz}$ of $5\ \text{m}\Omega$ compared with $600\ \text{m}\Omega$ to $700\ \text{m}\Omega$ for conventional slotted connectors, thus drastically reducing unwanted radiation of RF energy. Contact resistance of the screen circuit is $0.2\ \text{m}\Omega$, and that of the inner circuit is $2\ \text{m}\Omega$.

The Suhner range of QL connectors comprises straight and angle cable plugs, straight and bulkhead cable jacks, a bulkhead jack, and various adaptors and accessories. Time-saving crimp cable entries or moisture-proof pressure sleeve entries may be specified.

Suhner Electronics Ltd.
The Technical Centre
Jefferson Way, Thame
Oxfordshire OX9 3UN
England

(616 M)

Precision quad op-amp

Precision Monolithics have introduced the OP-11, a precision quad op-amp with matched input offset voltages and matched CMRR. Individual amplifiers have input offset voltages as low as $500\ \mu\text{V}$, symmetrical slew rates in the positive and negative-going directions, low noise, and low drift. The OP-11 is ideal for precision instrumentation amplifier designs, active filters and other applications needing small size and high accuracy in a single chip quad op-amp with a LM 148/HA 4741 standard pin out.

Bourns (Trimpot) Limited
Hodford House
17/27 High Street, Hounslow
Middlesex TW3 1TE
England

(615 M)

2400 LSI data modem

The Data Communications Division of Penril Corp. has announced the introduction of a new 2400/1200 bps synchronous LSI modem offering superior performance and reliability.

The 2400 LSI is designed for 2400/1200 bps operation over 2- or 4-wire dedicated or dial networks. The modem employs a four-phase modulation technique conforming to CCITT Type A or B and is fully on-line compatible with the Bell System 201B or C Data Sets, most other PSK modems, as well as the Bell 801 Automatic Calling Unit. The modem features fast synchronisation for use in multi-station polled networks and point-to-point applications.

The 2400 LSI is equipped with an equaliser that is strappable in either the transmit or receive sections. Strap options are provided for selecting transmitter output levels, carrier detect level, internal or external clock, carrier detector response time, RTS/CTS delays, and equalisation.

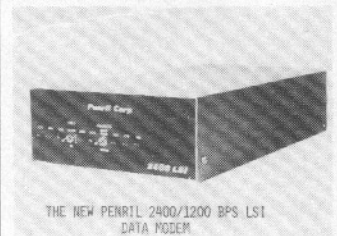

When operating over the Direct-Distance-Dial Network, automatic answer circuits enable unattended call answering when connected via a Type CBS or CBT data coupler. In the Auto Answer mode an answer tone of $2025\ \text{Hz}$ is generated for 3 seconds to switch over 801 devices or alert manual calling stations of call completion, depending upon application. Built-in local digital and analog loopback diagnostic capabilities reduce the time required to localise system malfunction. A built-in test pattern generator and receiver pattern detector greatly simplify on and off line testing and troubleshooting. No external test equipment is required to install or troubleshoot the Penril 2400 LSI. Basic modem functions are implemented in four MOS/LSI chips, providing reduced size and increased reliability, contained on one compact printed circuit card. The modem card measures 5 inches by 12 inches ($12.5\ \text{cm}$ by $30\ \text{cm}$), mounted in a free-standing enclosure. The enclosure contains an integral power supply and measures 3-inches high by 7-3/8 inches wide by 12-5/8 inches deep ($7.5\ \text{cm}$ by $18.5\ \text{cm}$ by $31.6\ \text{cm}$).

Penril Corp.
5520 Randolph road, Rockville
Maryland 20852
USA

(617 M)

T.T.L. 74 I.C.'s By TEXAS, NATIONAL, I.T.T. FAIRCHILD Etc.

7400 14p	7413 30p	7432 25p	7454 15p	7490 35p	74121 25p	74139 100p	74156 70p	74174 100p	74189 350p
7401 14p	7414 60p	7431 25p	7450 25p	7491 75p	74122 40p	74141 60p	74157 70p	74175 75p	74190 140p
7402 14p	7416 30p	7430 75p	7451 25p	7492 75p	74123 270p	74142 270p	74158 90p	74176 90p	74191 140p
7403 14p	7417 30p	7440 15p	7452 25p	7493 40p	74125 50p	74143 60p	74159 100p	74177 100p	74192 140p
7404 14p	7418 20p	7441 60p	7453 25p	7494 40p	74126 50p	74144 270p	74160 270p	74178 75p	74193 140p
7405 14p	7422 20p	7442 65p	7474 30p	7496 70p	74130 100p	74145 75p	74162 90p	74179 100p	74194 140p
7406 14p	7423 20p	7443 65p	7475 30p	7497 70p	74131 100p	74146 75p	74163 90p	74180 100p	74195 75p
7407 40p	7425 25p	7444 65p	7476 30p	7498 40p	74132 65p	74148 160p	74165 125p	74181 200p	74196 100p
7408 20p	7426 25p	7445 75p	7481 30p	7499 40p	74135 100p	74150 120p	74166 125p	74182 75p	74197 100p
7409 20p	7427 25p	7446 75p	7482 30p	7500 40p	74136 100p	74151 100p	74167 125p	74183 75p	74198 100p
7410 15p	7428 40p	7451 75p	7483 30p	7510 50p	74137 100p	74152 65p	74168 200p	74184 150p	74199 185p
7411 20p	7430 15p	7451 75p	7484 25p	7511 50p	74138 125p	74153 80p	74169 200p	74185 150p	
7412 20p		7453 15p	7485 20p	7512 50p		74154 70p	74170 150p	74186 350p	

SEMICONDUCTORS by MULLARD, TEXAS, MOTOROLA, SIEMENS, I.T.T., RCA.

AA113 10p	BA138 16p	BC168R 14p	BC548C 14p	BF123 45p	BF336 35p	BY164 50p	OC140 150p	TI932A 230p	2N1305 30p
AA144 10p	BA148 16p	BC168L 15p	BC549B 13p	BF125 45p	BF337 35p	BY164 50p	OC171 40p	TI932B 230p	2N1306 30p
AA217 30p	BA154 17p	BC169 15p	BC549C 14p	BF127 50p	BF368 60p	BY170 50p	OC200 80p	TI941 30p	2N1307 30p
AC121 30p	BA157 15p	BC171 12p	BC551 13p	BF166 30p	BF394 50p	C1184 20p	OPR12 70p	TI941A 10p	7N1171 22p
AC126 19p	BA172 15p	BC172C 12p	BC174 80p	BF167 25p	BF398 20p	E201 50p	TI929 45p	TI941H 75p	2N2219A 25p
AC127 19p	BA176 15p	BC178A 16p	BC179 15p	BF173 25p	BF424 50p	E202 100p	TI929A 47p	TI941C 80p	2N2801 30p
AC129/251	BA116 16p	BC182 10p	BC171 25p	BF179 25p	BF431 100p	E204 45p	TI929C 75p	TI942A 80p	2N2906 16p
AC129 18p	BA113 5p	BC183 12p	BC172 15p	BF196C 25p	BF432 50p	E300 17p	TI930 50p	TI942B 85p	2N2907 30p
AC151 25p	BA136 5p	BC183 10p	BD121 85p	BF180 30p	BF485 30p	E310 60p	TI930A 60p	TI9295 70p	2N3053 20p
AC152 40p	BB195A 25p	BC183L 12p	BD123 85p	BF181 25p	BF487 25p	E320 100p	TI930B 60p	TI9295S 55p	2N3054 80p
AC176 20p	BB110 45p	BC184 10p	BD124 85p	BF182 30p	BF488 25p	E430 125p	TI930C 60p	TI930 50p	2N3055 60p
AC177 20p	BC107 10p	BC184L 12p	BD131 35p	BF183 30p	BF497 20p	MA340 45p	TI931 50p	TI931 50p	2N3439 60p
AC179 30p	BC108 10p	BC186 34p	BD132 35p	BF186 75p	BF491 80p	M5A06 45p	TI911A 15p	TI931A 15p	2N3702 11p
AD149 60p	BC108B 15p	BC186 15p	BD133 45p	BF194 10p	BF492 20p	OA10 40p	TI918 65p	TI937A 10p	2N3703 12p
AD161 40p	BC108C 14p	BC187 11p	BD135 45p	BF195 15p	BF493 12p	OA42 70p	TI919 50p	TI937C 10p	2N3704 11p
AD162 40p	BC109C 15p	BC172L 12p	BD136 45p	BF196 10p	BF501 20p	OA90 60p	TI922 60p	TI940C 10p	2N3705 12p
AD162/2MP	BC109 15p	BC183L 12p	BD138 45p	BF197 25p	BF502 20p	OA91 60p	TI922A 65p	TI940D 10p	2N3706 11p
AF14 22p	BC117 10p	BC124 13p	BD138 38p	BF198 25p	BF508 35p	OA202 8p	TI922B 65p	TI940E 10p	2N3711 12p
AF115 22p	BC126 20p	BC124L 14p	BD140 40p	BF199 25p	BF520 20p	OC23 200p	TI922C 65p	TI940F 10p	2N3712 12p
AF116 22p	BC146 12p	BC128 35p	BD141 40p	BF180 30p	BF540 30p	OC25 100p	TI912 10p	TI940G 10p	2N3713 300p
AF117 22p	BC146 12p	BC128 35p	BD142 40p	BF181 25p	BF509 20p	OC23 75p	TI913 10p	TI940H 10p	2N3714 300p
AF118 22p	BC147 10p	BC128 35p	BD143 40p	BF182 25p	BF510 20p	OC25 100p	TI913A 10p	TI940I 10p	2N3715 300p
AF121 25p	BC148 10p	BC131 15p	BD143 40p	BF183 25p	BF511 20p	OC27 75p	TI913B 10p	TI940J 10p	2N3716 300p
AF122 25p	BC149 10p	BC131 15p	BD144 40p	BF184 25p	BF512 20p	OC27 75p	TI913C 10p	TI940K 10p	2N3717 300p
AF123 25p	BC149 10p	BC131 15p	BD145 40p	BF185 25p	BF513 20p	OC27 75p	TI913D 10p	TI940L 10p	2N3718 300p
AS126 45p	BC157 10p	BC138 12p	BD176/201 90p	BF258 25p	BY100 20p	OC71 25p	TI924 118p	2N456A 90p	2N4062 14p
BA114 7p	BC158 12p	BC138 12p	BD176/201 90p	BF259 25p	BY112 20p	OC71 25p	TI924A 118p	2N456B 90p	2N4063 14p
BA121 5p	BC159 10p	BC137 10p	BF121 45p	BF274 15p	BY123 15p	OC75 30p	TI924B 118p	2N456C 90p	2N4064 14p
	BC167A 12p	BC137 10p	BF124 35p	BF274 15p	BY123 15p	OC75 30p	TI924C 118p	2N456D 90p	2N4065 14p
		BC147H 13p	BF274 35p	BF274 15p	BY123 15p	OC81 20p	TI924D 118p	2N456E 90p	2N4066 14p
		BC148 12p				OC85 50p	TI924E 118p	2N456F 90p	2N4067 14p
						OC84 50p	TI924F 118p	2N456G 90p	2N4068 14p
							TI924G 118p	2N456H 90p	2N4069 14p
							TI924H 118p	2N456I 90p	2N4070 14p
							TI924I 118p	2N456J 90p	2N4071 14p
							TI924J 118p	2N456K 90p	2N4072 14p
							TI924K 118p	2N456L 90p	2N4073 14p
							TI924L 118p	2N456M 90p	2N4074 14p
							TI924M 118p	2N456N 90p	2N4075 14p
							TI924N 118p	2N456O 90p	2N4076 14p
							TI924O 118p	2N456P 90p	2N4077 14p
							TI924P 118p	2N456Q 90p	2N4078 14p
							TI924Q 118p	2N456R 90p	2N4079 14p
							TI924R 118p	2N456S 90p	2N4080 14p
							TI924S 118p	2N456T 90p	2N4081 14p
							TI924T 118p	2N456U 90p	2N4082 14p
							TI924U 118p	2N456V 90p	2N4083 14p
							TI924V 118p	2N456W 90p	2N4084 14p
							TI924W 118p	2N456X 90p	2N4085 14p
							TI924X 118p	2N456Y 90p	2N4086 14p
							TI924Y 118p	2N456Z 90p	2N4087 14p
							TI924Z 118p	2N456AA 90p	2N4088 14p
							TI924AA 118p	2N456AB 90p	2N4089 14p
							TI924AB 118p	2N456AC 90p	2N4090 14p
							TI924AC 118p	2N456AD 90p	2N4091 14p
							TI924AD 118p	2N456AE 90p	2N4092 14p
							TI924AE 118p	2N456AF 90p	2N4093 14p
							TI924AF 118p	2N456AG 90p	2N4094 14p
							TI924AG 118p	2N456AH 90p	2N4095 14p
							TI924AH 118p	2N456AJ 90p	2N4096 14p
							TI924AJ 118p	2N456AK 90p	2N4097 14p
							TI924AJ 118p	2N456AL 90p	2N4098 14p
							TI924AK 118p	2N456AM 90p	2N4099 14p
							TI924AL 118p	2N456AN 90p	2N4100 14p
							TI924AL 118p	2N456AO 90p	2N4101 14p
							TI924AM 118p	2N456AP 90p	2N4102 14p
							TI924AM 118p	2N456AQ 90p	2N4103 14p
							TI924AN 118p	2N456AR 90p	2N4104 14p
							TI924AN 118p	2N456AS 90p	2N4105 14p
							TI924AO 118p	2N456AT 90p	2N4106 14p
							TI924AO 118p	2N456AU 90p	2N4107 14p
							TI924AO 118p	2N456AV 90p	2N4108 14p
							TI924AO 118p	2N456AW 90p	2N4109 14p
							TI924AO 118p	2N456AX 90p	2N4110 14p
							TI924AO 118p	2N456AY 90p	2N4111 14p
							TI924AO 118p	2N456AZ 90p	2N4112 14p
							TI924AO 118p	2N456BA 90p	2N4113 14p
							TI924AO 118p	2N456BB 90p	2N4114 14p
							TI924AO 118p	2N456BC 90p	2N4115 14p
							TI924AO 118p	2N456BD 90p	2N4116 14p
							TI924AO 118p	2N456BE 90p	2N4117 14p
							TI924AO 118p	2N456BF 90p	2N4118 14p
							TI924AO 118p	2N456BG 90p	2N4119 14p
							TI924AO 118p	2N456BH 90p	2N4120 14p
							TI924AO 118p	2N456BI 90p	2N4121 14p
							TI924AO 118p	2N456BJ 90p	2N4122 14p
							TI924AO 118p	2N456BK 90p	2N4123 14p
							TI924AO 118p	2N456BL 90p	2N4124 14p
							TI924AO 118p	2N456BM 90p	2N4125 14p
							TI924AO 118p	2N456BN 90p	2N4126 14p
							TI924AO 118p	2N456BO 90p	2N4127 14p
							TI924AO 118p	2N456BP 90p	2N4128 14p
							TI924AO 118p	2N456BQ 90p	2N4129 14p
							TI924AO 118p	2N456BR 90p	2N4130 14p
							TI924AO 118p	2N456BS 90p	2N4131 14p
							TI924AO 118p	2N456BT 90p	2N4132 14p
							TI924AO 118p	2N456BU 90p	2N4133 14p
							TI924AO 118p	2N456BV 90p	2N4134 14p
							TI924AO 118p	2N456BW 90p	2N4135 14p
							TI924AO 118p	2N456BX 90p	2N4136 14p
							TI924AO 118p	2N456BY 90p	2N4137 14p
							TI924AO 118p	2N456BZ 90p	2N4138 14p
							TI924AO 118p	2N456CA 90p	2N4139 14p
							TI924AO 118p	2N456CB 90p	2N4140 14p
							TI924AO 118p	2N456CC 90p	2N4141 14p
							TI924AO 118p	2N456CD 90p	2N4142 14p
							TI924AO 118p	2N456CE 90p	2N4143 14p
</									