

up-to-date electronics for lab and leisure

ELEKTOR 25

May 1977 45p / USA \$1.50



formant- a music synthesizer

**from quadro to surround sound
music cleaner**

ELEKTOR

Editor : W. van der Horst

Deputy editor : P. Holmes

Technical editors : J. Barendrecht
G.H.K. Dam
E. Krempelsauer
G.H. Nachbar
Fr. Scheel
K.S.M. Walraven

Art editor : C. Sinke

Subscriptions : Mrs. A. van Meyel

U.K. editorial offices, administration and advertising:
6, Stour Street, Canterbury CT1 2XZ, Kent, U.K.
Tel.: Canterbury (0227)-54430. Telex: 965504.

Bank: 1. Midland Bank Ltd., Canterbury, A/C no. 11014587,
Sorting code 40-16-11, Giro no. 3154254.
2. U.S.A. and Canada: c/o World Way Postal Center
P.O. Box 80689, Los Angeles, Cal. 90080,
A/C no. 12350-04207.

Assistant Manager and Advertising : R.G. Knapp
Editorial : T. Emmens

Elektor is published monthly on the third friday of each month.

1. U.K. and all countries except the U.S.A. and Canada:

Cover price £ 0.45.

Number 27/28 (July/August), is a double issue, 'Summer Circuits', price £ 0.90.

Single copies (incl. back issues) are available by post from our Canterbury office, at £ 0.60 (surface mail) or £ 0.95 (air mail).

Subscriptions for 1977, January to December incl., £ 6.25 (surface mail) or £ 11.— (air mail).

Subscriptions from May to December 1977, £4.15 (surface mail).

2. For the U.S.A. and Canada:

Cover price \$ 1.50.

Number 27/28 (July/August), is a double issue, 'Summer Circuits', price \$ 3.—.

Single copies (incl. back issues) \$ 1.50 (surface mail) or \$ 2.25 (air mail).

Subscriptions for 1977, January to December incl., \$ 18.— (surface mail) or \$ 27.— (air mail).

Subscriptions from May to December 1977, \$12.00 (surface mail). All prices include post & packing.

Change of address. Please allow at least six weeks for change of address. Include your old address, enclosing, if possible, an address label from a recent issue.

Letters should be addressed to the department concerned:
TQ = Technical Queries, ADV = Advertisements, SUB = Subscriptions;
ADM = Administration; ED = Editorial (articles submitted for publication etc.); EPS = Elektor printed circuit board service.
For technical queries, please enclose a stamped, addressed envelope.

The circuits published are for domestic use only. The submission of designs or articles to Elektor implies permission to the publishers to alter and translate the text and design, and to use the contents in other Elektor publications and activities. The publishers cannot guarantee to return any material submitted to them. All drawing, photographs, printed circuit boards and articles published in Elektor are copyright and may not be reproduced or imitated in whole or part without prior written permission of the publishers.

Patent protection may exist in respect of circuits, devices, components etc. described in this magazine.
The publishers do not accept responsibility for failing to identify such patent or other protection.

National advertising rates for the English edition of Elektor and/or international advertising rates for advertising at the same time in the English, Dutch and German issues are available on request.

Distribution: Spotlight Magazine Distributors Ltd,
Spotlight House 1, Bentwell Road, Holloway, London N7 7AX.

Copyright © 1977 Elektor publishers Ltd — Canterbury.

Printed in the Netherlands.

DECODER

What is a TUN?
What is 10 n?
What is the EPS service?
What is the TQ service?
What is a missing link?

Semiconductor types

Very often, a large number of equivalent semiconductors exist with different type numbers. For this reason, 'abbreviated' type numbers are used in Elektor wherever possible:

- '741' stand for μ A741, LM741, MC641, MIC741, RM741, SN72741, etc.
- 'TUP' or 'TUN' (Transistor, Universal, PNP or NPN respectively) stand for any low frequency silicon transistor that meets the following specifications:

V_{CEO} , max	20V
I_C , max	100 mA
I_{fe} , min	100
P_{tot} , max	100 mW
f_T , min	100 MHz

Some 'TUN's are: BC107, BC108 and BC109 families; 2N3856A, 2N3859, 2N3860, 2N3904, 2N3947, 2N4124. Some 'TUP's are: BC177 and BC178 families; BC179 family with the possible exception of BC159 and BC179; 2N2412, 2N3251, 2N3906, 2N4126, 2N4291.

- 'DUS' or 'DUG' (Diode Universal, Silicon or Germanium respectively) stands for any diode that meets the following specifications:

	DUS	DUG
V_R , max	25V	20V
I_F , max	100mA	35mA
I_R , max	1 μ A	100 μ A
P_{tot} , max	250mW	250mW
C_D , max	5pF	10pF

Some 'DUS's are: BA127, BA217, BA218, BA221, BA222, BA317, BA318, BAX13, BAY61, 1N914, 1N4148.

Some 'DUG's are: OA85, OA91, OA95, AA116.

- 'BC107B', 'BC237B', 'BC547B' all refer to the same 'family' of almost identical better-quality silicon transistors. In general, any other member of the same family can be used instead.

BC107 (-8, -9) families:

BC107 (-8, -9), BC147 (-8, -9), BC207 (-8, -9), BC237 (-8, -9), BC317 (-8, -9), BC347 (-8, -9), BC547 (-8, -9), BC171 (-2, -3), BC182 (-3, -4), BC382 (-3, -4), BC437 (-8, -9), BC414

BC177 (-8, -9) families:

BC177 (-8, -9), BC157 (-8, -9), BC204 (-5, -6), BC307 (-8, -9), BC320 (-1, -2), BC350 (-1, -2), BC557 (-8, -9), BC251 (-2, -3), BC212 (-3, -4), BC512 (-3, -4), BC261 (-2, -3), BC416.

Resistor and capacitor values

When giving component values, decimal points and large numbers of zeros are avoided wherever

possible. The decimal point is usually replaced by one of the following abbreviations:

p (pico-) = 10^{-12}

n (nano-) = 10^{-9}

μ (micro-) = 10^{-6}

m (milli-) = 10^{-3}

k (kilo-) = 10^3

M (mega-) = 10^6

G (giga-) = 10^9

A few examples:

Resistance value 2k7: 2700 Ω .

Resistance value 470: 470 Ω .

Capacitance value 4p7: 4.7 pF, or 0.000 000 000 004 7 F . . .

Capacitance value 10n: this is the international way of writing

10,000 pF or .01 μ F, since 1 n is

10^{-9} farads or 1000 pF.

Resistors are $\frac{1}{2}$ Watt 5% carbon

types, unless otherwise specified.

The DC working voltage of

capacitors (other than electro-

lytics) is normally assumed to be

at least 100 V. As a rule of thumb,

a safe value is usually approxi-

mately twice the DC supply

voltage.

CONTENTS

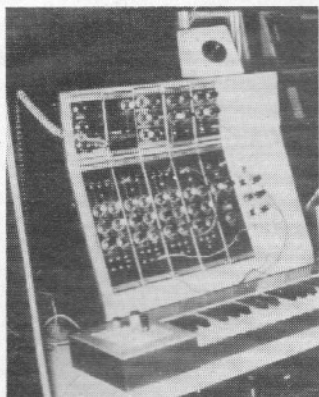

A synthesiser, such as the **formant**, consists basically of a simple keyboard backed up by a boxfull of electronics!

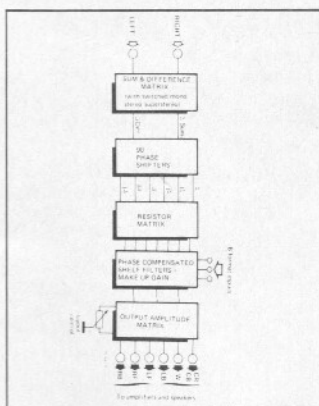

Block diagram of a domestic **ambisonic decoder** of medium complexity for 2-channel (45JB) material.

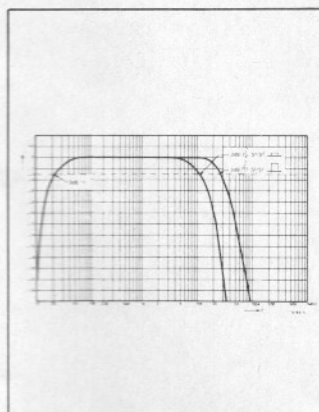

Gain/frequency response curve of the **music cleaner**. The ultimate slope of all filters is 18 dB/octave.

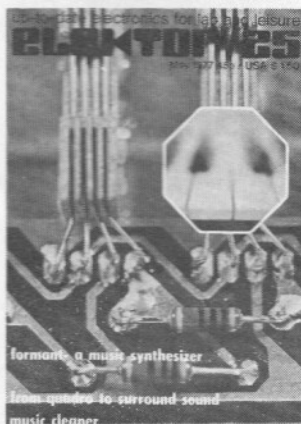

One of the most essential parts of any **music synthesiser** is the keyboard. This is what it looks like from underneath . . .

Formant — the Elektor music synthesiser (1) . . . 5-14
C. Chapman

This article is the introduction to a series of articles describing 'Formant', the Elektor music synthesiser. As synthesisers are something of a mystery to many people this article will serve as a general introduction to them, as well as describing the basic principles of Formant.

from quadro to surround sound 5-19
P. Fellgett and M. Gerzon

In previous articles ('Quadrille' and 'music of the spheres', Elektor 17, September 1976, p. 910) it was noted that 'Ambisonics' was perhaps the most promising of the quadrophonic systems proposed so far. This article explains the basic theory and philosophy of Ambisonics.

stereo encoder — A. Bosschaert 5-26

This relatively simple circuit will combine two independent audio signals into a multiplexed stereo signal similar to that used to modulate an FM transmitter for stereo transmissions.

precision V to f converter 5-29

slotless model car track (2) 5-30

This month's article describes the circuit of the multiplex encoder, and the principle of the decoder. The board layout for the infra-red transmitter will also be given.

missing link 5-39

op-amp frequency compensation 5-40
the why and the how

morse call sign generator — A. Peters 5-41

music cleaner 5-43

A treble and rumble filter that can be used in virtually any hi-fi system to get rid of the snaps, crackles, pops and (g)rumbles without getting rid of half the music.

active loudspeaker-crossover filters (1) 5-46

Few things can so hold the attention of the serious audiophile as do loudspeakers. This applies with particular strength to those whose fingers always have the experimenter's itch. One of the ways of sinking cash into an existing system is to replace the 'passive' separating ('crossover') filters by 'active' types.

albar mk II . . . a b.f.s. 5-52

market 5-55

advertiser's index 5-64

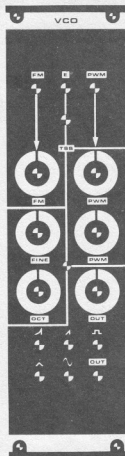

The Finest

The "S.K.A." Plastic Keyboard was developed by Kimber Allen Ltd in co-operation with a Swedish company and the manufacturers state that in their opinion it is the finest moulded plastic keyboard made and is not to be confused with cheaper keyboards available.

The keys are moulded in Acrylic plastic, a material chosen for its hard wearing properties and ideal feel to the touch. They are moulded in two parts, the key face, which has to be perfect in appearance and finish, and the action, which has to be strong and carry the mechanism. The strong section of aluminium extrusion upon which they are mounted is specially designed to take all the pressures of playing. Springs, felts, and contact actuators are supplied ready-fitted.

The contact assemblies are constructed of laminated bakelite, thus giving smooth slot walls and completely free movement of the gold-clad contact wires. Types available as follows (Contact pairs normally open):

GJ—SPCO:	24p each	GE—4 pairs:	45p each
GB—2 pairs:	27p each	GH—5 pairs:	57p each
GC—3 pairs:	36p each	4PS—SPCO & 3 prs:	53p each
Palladium wire Bus Bars — 1 octave lengths:	50p each		

We also stock kits and PCBs for the P.E. Synthesiser, P.E. Joanna (electronic piano), P.E. Minisonic, and other sound synthesising and modifying projects published in Practical Electronics. Send SAE for full list (Overseas send 40p).

PHONOSONICS

DEPT. EL25, 22 HIGH STREET
SIDCUP, KENT DA14 6EH

ELEKTOR FORMANT SYNTHESISER

KITS & P.C.B.'s

Details in our
lists—send s.a.e.

PLUS:

KEYBOARDS



& CONTACTS



U.K. POST & HANDLING:	37 Note C-C Keyboard:	£25.50
Keyboards: £1.50 each	49 Note C-C Keyboard:	£32.25
Contacts:	61 Note C-C Keyboard:	£39.75
Orders under £15.00: 25p		
Orders over £15.00: 50p		

VAT: Add 12% to final total on all U.K. orders

EXPORT ORDERS ARE WELCOME but please see our price list for Export Postage Rates. N.B. EIRE, CHANNEL ISLES & B.F.P.O. classify as Export.

MAIL ORDER AND C.W.O. ONLY — SORRY BUT NO CALLERS PLEASE

Prices are correct at time of Press, E. & O.E. Delivery subject to availability.

PHILTRON

Electronic Components Specialists

325, DUTOIT STREET, P.O. BOX 2749, PRETORIA,
0001 TRANSVAAL. REPUBLIC OF SOUTH AFRICA

Telegraph address "TRINITRON"

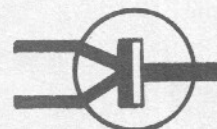

Stockists of

Heathkit - Siemens -
Monsanto -
Texas - Interface -
Linear - MOS - Signetics -
Fairchild
PRODUCTS

Crystals &
Sockets
Piezo Electric
Ceramics



ELEKTOR
MAGAZINES
BINDERS
PRINTED CIRCUIT
BOARDS

Electronic books,
Projects, data etc.

Capacitors

Tantalum
Polyester
Electrolytic
Co-axial &
P.C. Mount

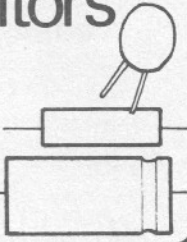

LED'S
Panel Meters

Toggle switches ...
Connectors ...
Potentiometers ...
Trim pots ...

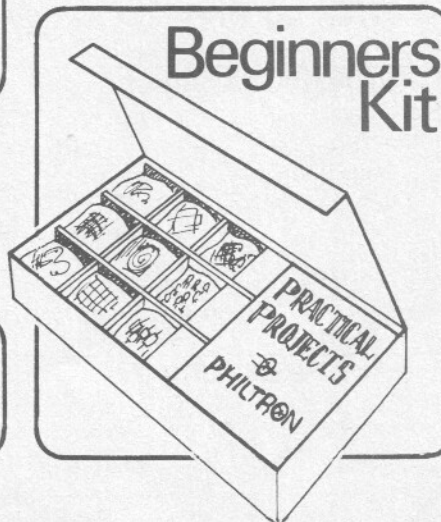

Resistors

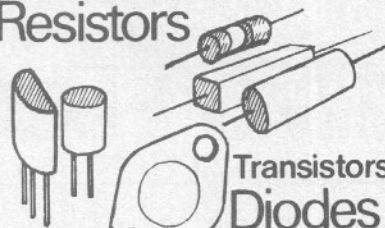

Transistors
Diodes

I.C.'s

Op Amps
Vol. Regs.,
Lin. Amps,
Digitals, Nor,
Latching etc.
etc.

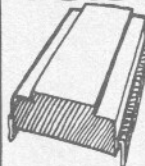

Relays

SCRS ... Triacs ...
Quaracs ... Variacs ...
Transformers



Inductors

Sole South African distributors for ELEKTOR
Trade Enquiries Welcome

formant= the elektor music synthesiser

C. Chapman

This article is the introduction to a series of articles describing 'Formant', the Elektor music synthesiser. This is an instrument of advanced specification that bears comparison with many commercially available synthesisers, but at a fraction of the cost.

As synthesisers are something of a mystery to many people this article will serve as a general introduction to them, as well as describing the basic principles of Formant.

A synthesiser may be defined as an electronic musical instrument whose tonal characteristics can be varied at will by the musician. This immediately makes the synthesiser different from conventional musical instruments, whose tonal characters are fixed by their physical construction. It also makes the synthesiser different from an electronic organ, since the latter has a fixed set of voices, generally imitative of conventional organ voices, whereas the synthesiser has no fixed tonal characteristics. The synthesiser may be used to imitate conventional instruments, but

on the other hand it may also produce sounds that cannot be produced by any conventional acoustic instrument, and which can be generated only by electronic means.

The synthesiser then, is an extremely versatile instrument, and it is a great pity that it is often used to provide monotonous background accompaniment to beat music, or as a 'band in a box' to produce television advertising jingles. Fortunately the capabilities of synthesisers have been fully exploited by musicians such as W. Carlos, K. Emerson, P. Moraz et al.

Principles of the Voltage Controlled Synthesiser.

The concept of the voltage-controlled synthesiser and related circuits was originated by Robert A. Moog. Any sound can be characterised by just three time dependent parameters, namely pitch, tone colour and volume, or to put it in electronic terms, fundamental frequency, harmonic content and amplitude. If these three parameters can be precisely controlled for the duration of a particular sound then that sound can accurately be synthesised. In practice this is obviously limited to fairly simple 'musical' and related sounds.

A synthesiser thus requires three basic circuit blocks: oscillators to generate sounds of the required pitch, filters to produce the required harmonic content, and amplifiers to obtain the required amplitude. Since the three parameters may vary during the existence of a particular sound there must be some means of rapidly controlling the characteristics of these circuit blocks, which is where the concept of voltage control comes in. The *pitch* of a voltage-controlled oscillator (VCO) may be varied by changing the control voltage applied to it. The *cutoff-frequency* of a voltage-controlled filter (VCF) may similarly be varied, as may the *gain* of a voltage-controlled amplifier (VCA).

Exponential Voltage Control

The fundamental design parameter of a synthesiser is the control voltage versus frequency characteristic of VCO's and VCF's. In many applications a linear characteristic is required, i.e. n volts per Hz. However, musicians are concerned not with linear frequency relationships but with musical intervals, the basic one of these being the octave. For each octave increase in pitch the frequency of a note doubles. This means that if the absolute frequency in Hertz is plotted against the relative frequency in octaves an exponential curve results, as shown in figure 2. It therefore seems more logical from a musical point of view to have a linear control voltage versus octaves characteristic. Figure 3 shows a control characteristic of 1 octave/volt (which is the standard generally adopted).

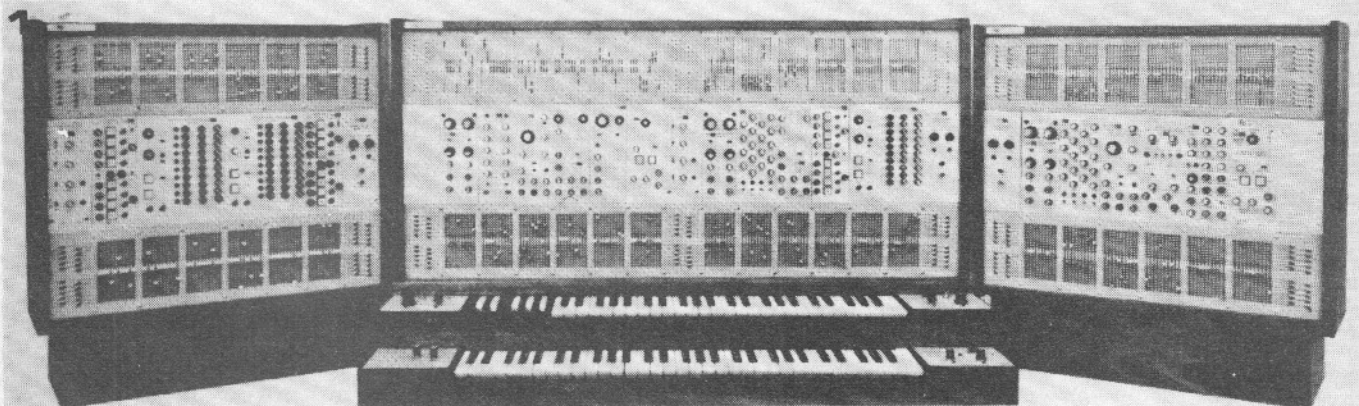

SAMPLE SYSTEM 4

This exponential control has several other advantages which will be discussed later.

An exponential (octave linear) control characteristic may be achieved by preceding a frequency linear VCO or current-controlled oscillator by an exponential generator whose output voltage or current doubles for each one volt increase in input voltage (figure 4). The exponential generator can be preceded by a summing amplifier into which is fed the main control voltage along with other voltages such as a D.C. offset voltage to transpose up and down the scale, and/or A.C. modulating voltages to produce vibrato effects.

Keyboard Voltage Control

In order to play the synthesiser there must be some method of feeding varying control voltages into the instrument. Since most (Western) musical instruments are tuned and played in the tempered tonic scale it seems logical that a synthesiser should conform to this scale, and the most obvious choice of 'input terminal' is a normal organ keyboard with electrical contacts.

The keyboard circuit (figure 5) consists of a potential divider chain comprising equal value resistors, fed from a current source. Since there are twelve semitone intervals (and hence twelve key contacts) to an octave, each resistor has a potential difference of $1/12$ volt across it. Depressing a particular key connects the voltage on that key contact out to the common bus rail, and thence to the voltage-controlled circuits.

Transposition

Like an electronic organ, a synthesiser keyboard has only a limited compass (three octaves in the case of Formant). In an organ a wider compass is obtained simply by selecting voices with a lower register. In a synthesiser the compass is extended by adding a D.C. offset voltage to the VCO input (or to the keyboard output) to transpose the range of the keyboard. This is shown in figure 6. An offset of +1 volt transposes the range up one octave, while an offset of -1 volt transposes it down one octave.

Figure 1. A comprehensive commercial music synthesiser, the Modell 'Sample System 4'.

Figure 2. Showing the exponential relationship between relative frequency in octaves and absolute frequency in Hertz.

2

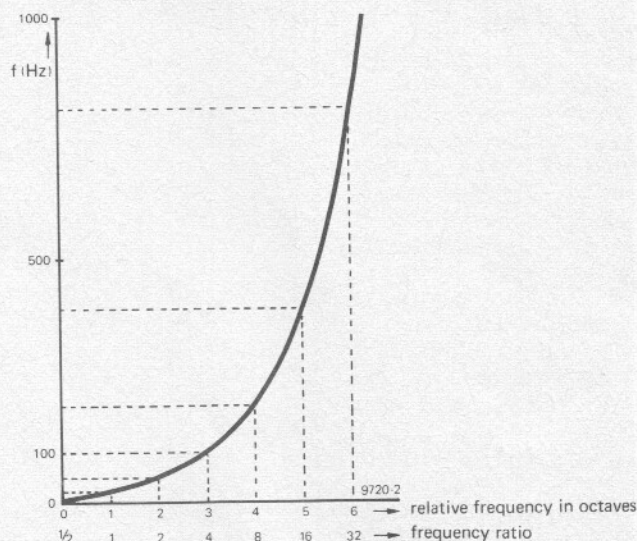

Advantages of exponential control

Figure 7 illustrates the principal advantage of exponential control, which is chording. This shows three VCO's each with three summing inputs. The first input of each VCO is commoned and connected to the keyboard. The second input of each VCO is connected to an independently variable D.C. offset voltage, while the third inputs are all commoned to another variable D.C. offset voltage. Suppose that the independent offsets are adjusted so that the adjacent VCO frequencies are one octave apart, e.g. 1 kHz, 2 kHz and 4 kHz. If the keyboard input increases by one volt then the frequencies will increase to 2 kHz, 4 kHz and 8 kHz respectively, which are still one octave apart. This would not be the case with a linear VCO. As an example, suppose the first frequency increases by 1 kHz to 2 kHz; the second will also increase by 1 kHz (to 3 kHz), and the third will increase to 5 kHz. This 2-3-5 kHz group no longer shows an octave relationship. Of course, with exponential control one is not confined simply to octave chords. By adjusting the independent offset controls the VCO's may be set up in any musical interval relationship. Additionally any number of VCO's may be employed. The commoned third inputs of the VCO's permit a common offset voltage to be fed to each VCO to transpose the whole chord up or down the scale. A further possibility is to add an offset voltage to the keyboard output to transpose the pitch of the entire synthesiser. This may seem a little confusing at first, but is not so in practice. To summarise:

1. VCO's may be arranged in chording

groups. The pitch of each VCO may be varied relative to other VCO's within a group to obtain the required chord, by adjusting the independent tuning controls.

2. The pitch of a chording group may be varied by adjusting the chord transposition control.

3. The pitch of the entire synthesiser may be transposed by an overall transposition control that adds a variable offset voltage to the keyboard output.

Voltage Controlled Filters

Voltage controlled filters employed in synthesisers are commonly of the lowpass type. A block diagram of their operation is given in figure 8. A D.C. voltage sets the cutoff frequency relative to the pitch of the VCO's, while a control voltage derived from the keyboard shifts this cutoff point up or down according to which note is played, so that all notes played, whether high or low, have the same harmonic content. Natural sounds are characterised by dynamic changes of tone colour. A note may start by having a 'bright' character with a large proportion of the higher harmonics, but these then decay rapidly leaving only the fundamental and lower harmonics. Provision must therefore be made to vary the cutoff point during the note. e.g. the cutoff point might initially start off at a fairly high frequency, which would decrease with time to cause the decay of the higher harmonics. This is achieved by means of an envelope shaper which generates a varying voltage having the required characteristics. The envelope shaper is controlled by a gate pulse which is

derived from a second set of contacts on the keyboard. The voltage versus cutoff frequency characteristic of the VCF's is again made exponential by preceding the control input of the VCF with an exponential generator.

Voltage controlled amplifiers

The VCA's are simply amplifiers whose gain may be varied by a control voltage. Their function is to control the duration of a sound, and also its dynamic amplitude characteristics, i.e. its attack, sustain and decay. The VCA is again controlled by an envelope shaper whose output voltage has a form corresponding to the amplitude envelope of the required sound. The VCA of course has no control voltage input from the keyboard, since the amplitude of all notes must remain the same and does not depend upon the frequency of the note being played.

The envelope shaper which controls the VCA is itself controlled by a gate pulse derived from the second contact set on the keyboard, and this determines the duration of the note played.

In the case of both the VCF's and VCA's the output voltage characteristic of the controlling envelope shaper (i.e. the manner in which the envelope voltage varies with time) can be adjusted by the musician. This is extremely important since the dynamic characteristics of a sound largely determine the character of the sound. Returning to conventional musical instruments as an example, if the attack transient at the beginning of a note is removed and only the steady note is played then it becomes extremely difficult to distinguish between many orchestral instruments. Indeed, it becomes difficult even to determine whether sounds so treated belong to string, brass or woodwind families.

3

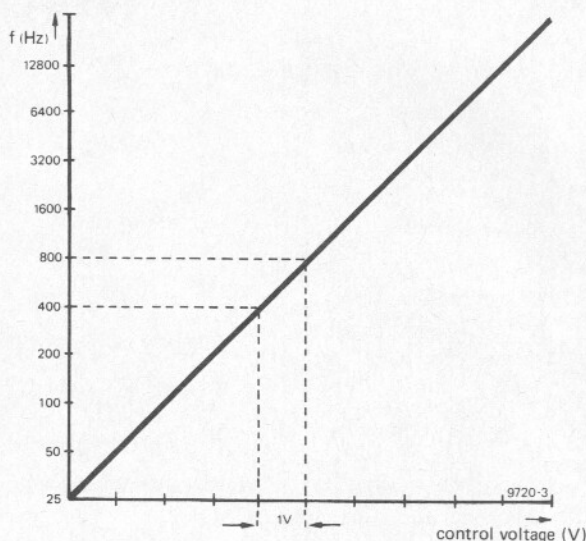

4

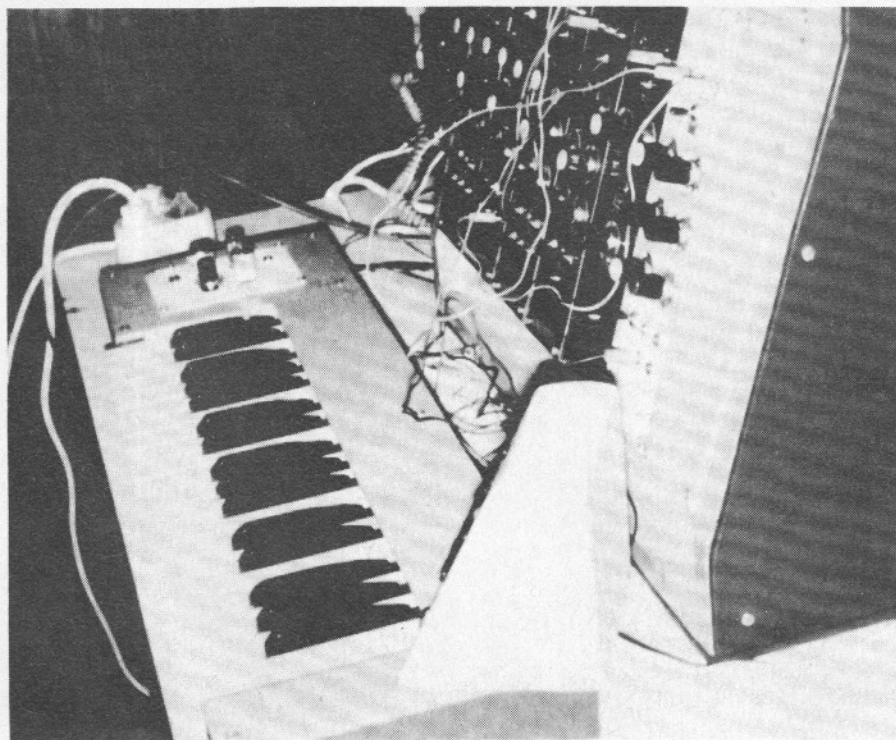
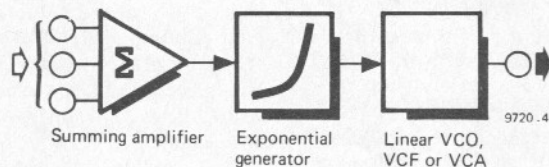

5

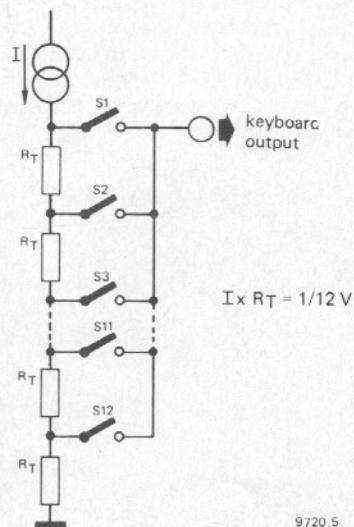

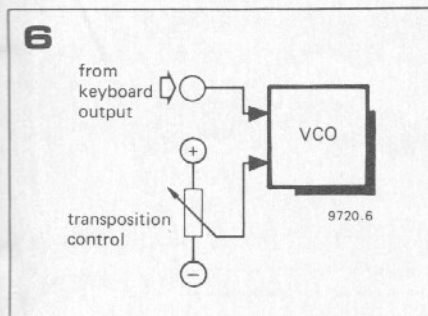

Figure 3. In common with other synthesisers, Formant has an exponential or octave-linear control characteristic of 1 octave/volt, i.e. if the control voltage is increased by 1 volt the frequency doubles.

Figure 4. Principle of a voltage-controlled synthesiser module according to Moog. This forms the basis of the voltage-controlled modules in Formant.

Figure 5. Showing how the control voltage is derived from the keyboard using a resistive potential divider.

Figure 6. By adding a DC offset voltage to the summing input of the VCO along with the keyboard voltage, the frequency range can be transposed. For example, an offset of +1 V makes the note one octave higher than that actually played on the keyboard. An offset of -1 V would make it one octave lower.

Figure 7. To play a chord, the offset of several VCO's may be adjusted to give the required musical intervals. They can then be controlled simultaneously by the keyboard, and may also be transposed together by a common D.C. voltage. This is known as 'chord transposition'.

Figure 8. The voltage-controlled filter (VCF) is controlled in exactly the same manner as the VCO. The keyboard controls its cutoff frequency, which can also be 'transposed' by a D.C. offset voltage. The third input allows dynamic changes of cutoff frequency during the playing of a note by means of an envelope shaper.

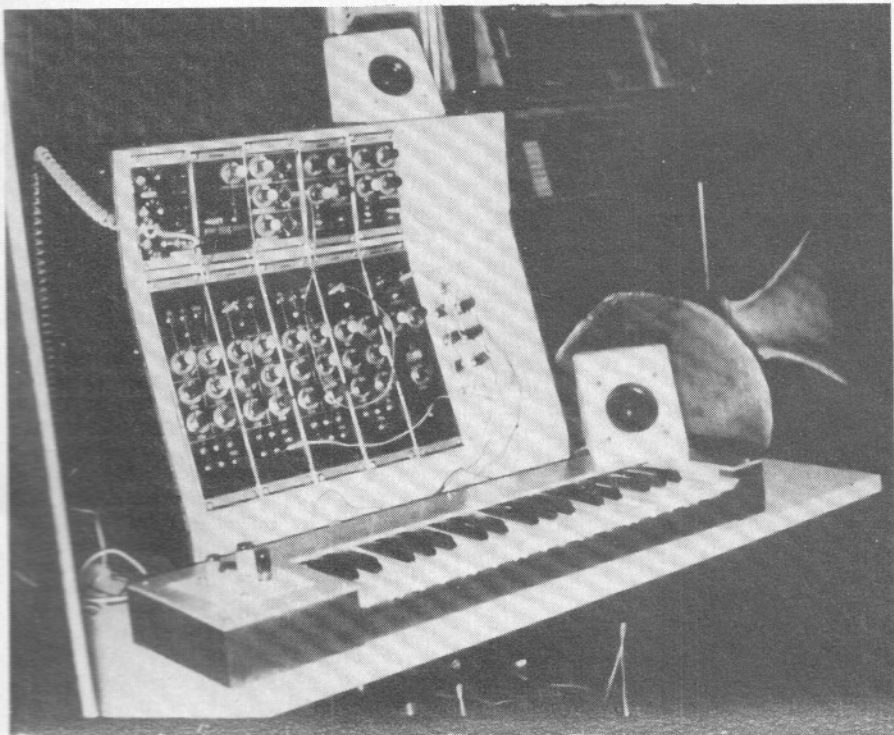
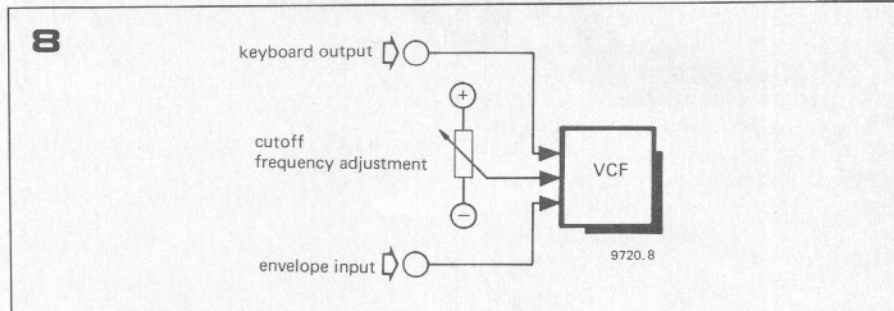
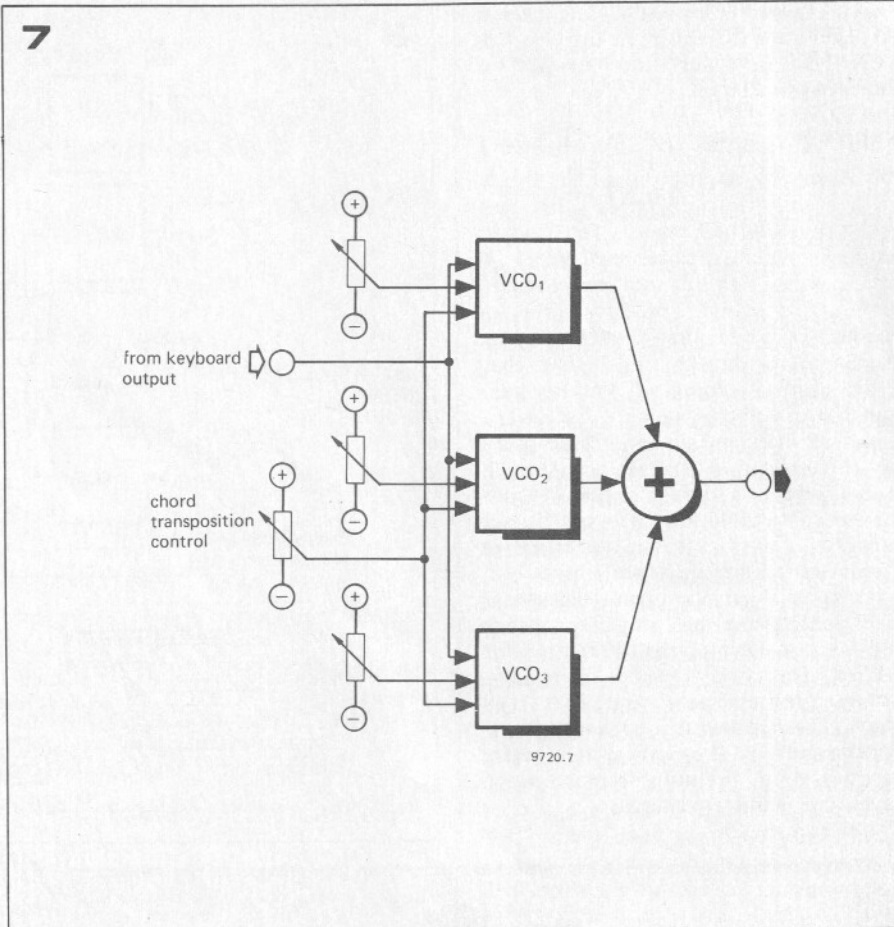

Synthesiser Block Diagram and Additional Circuits

Figure 9 shows the block diagram of a basic synthesiser, which contains all the circuits previously described plus a few extras.

At the bottom of the diagram is the keyboard and its interface circuits. These consist basically of the control voltage potential divider, the gate pulse generator and the envelope shapers. In addition there are low-frequency oscillators that provide a signal for periodic modulation of the voltage controlled circuits (e.g. for effects such as vibrato) plus a noise voltage generator to provide random modulation.

The block containing the VCO's needs little explanation, except for the addition of a noise generator. Since this generates a stochastic signal of no fixed pitch its frequency is not controlled by the keyboard, but the noise signal can be processed by passing through the VCF's and VCA's to produce effects such as wind, water, rain, thunder, steam trains, applause etc., as well as totally unnatural sounds.

The VCO and noise signals are passed through the VCF and then through the VCA, both of which are controlled by the envelope shapers.

Tonal Character of Synthesisers

The foregoing description of the basics of synthesisers can hardly give any impression of the range of tonal possibilities available with a synthesiser. To begin with, it should not be imagined that the sound produced by a synthesiser is like that produced by an electronic organ. A synthesiser has much more in common with conventional musical instruments. Whereas the sound of an electronic organ has a fairly static character, a synthesiser is much more lively and dynamic. The reasons for this are twofold. Firstly, a synthesiser permits precise control of the dynamic characteristics of the sounds produced, whereas an electronic organ (unless it is an expensive one) has only fixed attack and decay characteristics that must suffice for every voice. Secondly, whereas most electronic organs are fixed phase, the synthesiser, with its phase-independent VCO's, can much better produce more 'natural' sounds, which have varying phase patterns.

(To be continued)

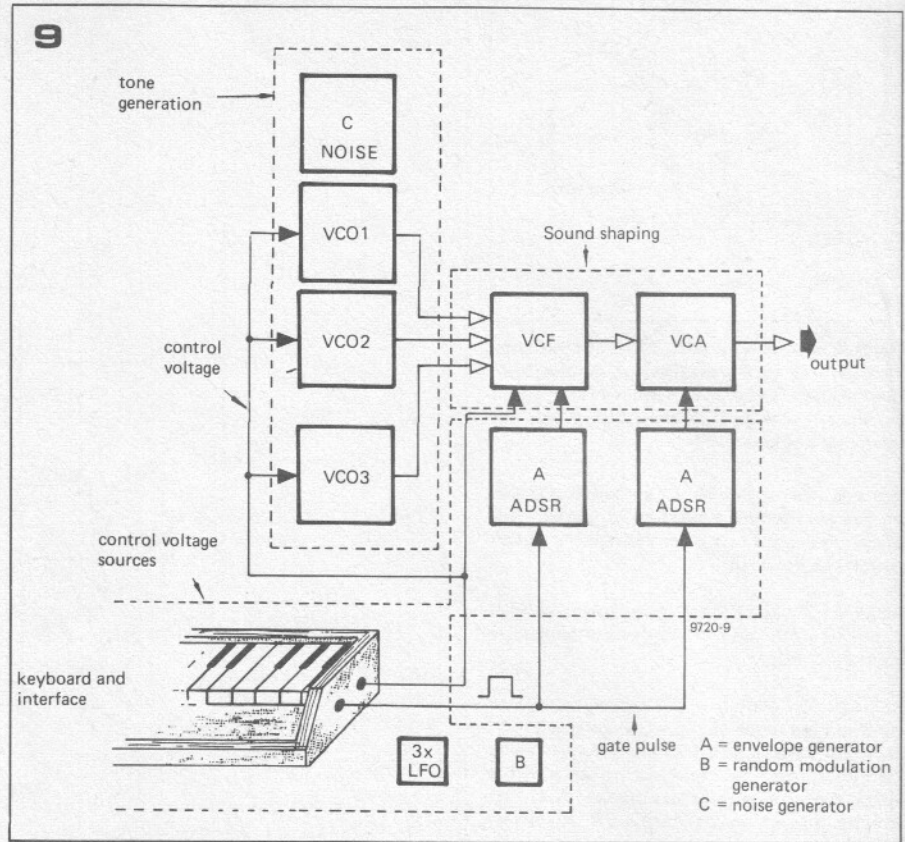
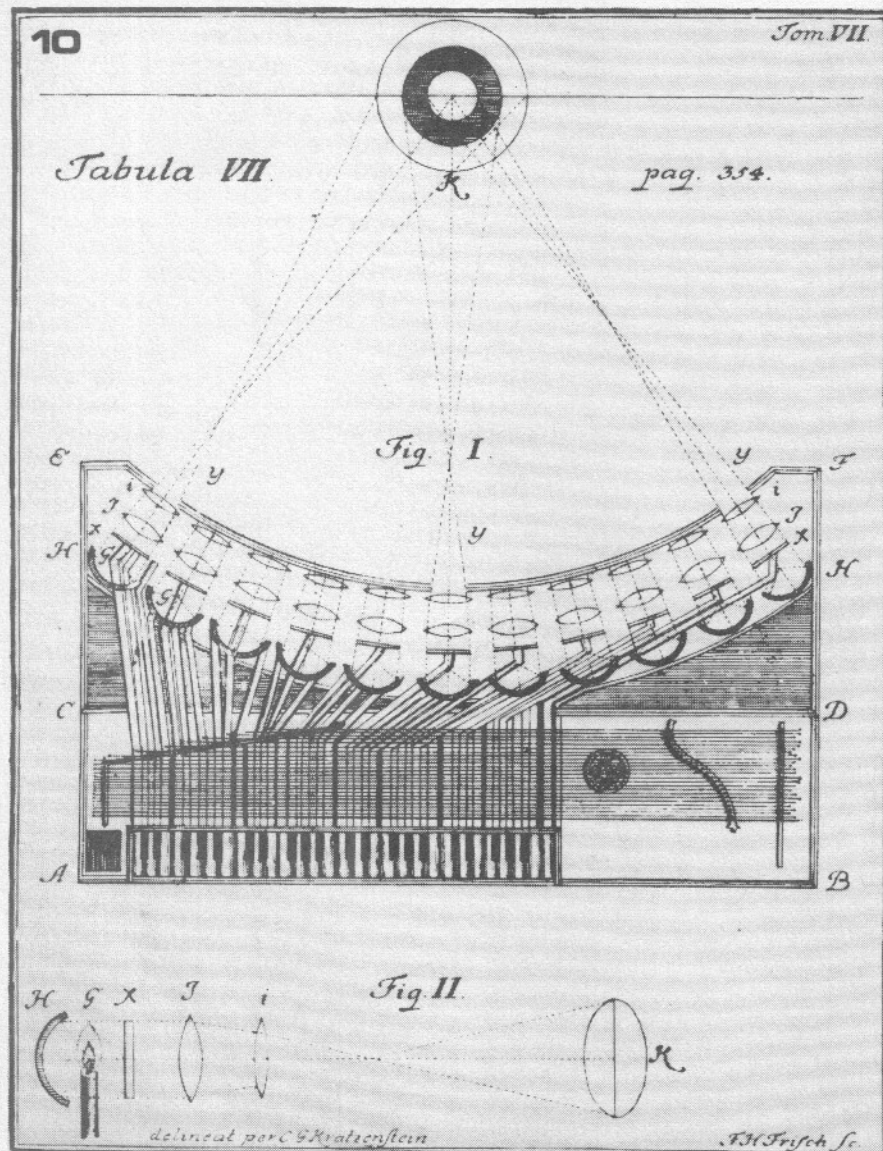

Figure 9. Layout of a basic synthesiser. Several additional blocks are shown such as low-frequency oscillators and noise generator to modulate the voltage-controlled modules, and a noise generator to produce effects such as wind, rain etc.

Figure 10. Forerunner of modern disco-lighting? An eighteenth century 'light organ'.



Literature

Moog R.A. 'Voltage-controlled electronic music modules'. *JAES* 13.3 July 1965.
 'A voltage-controlled low-pass, high-pass filter for audio signal processing'. *AES Preprint* 413, 1965.
 Burhans R. 'Simplified educational music synthesiser'. *JAES* 19.2, February 1971.
 Orr. T. and Thomas D.W., 'Electronic Sound Synthesiser'. *Wireless World*, August-October 1973.
 Simonton J. 'Build a modular electronic music synthesiser'. *Radio-Electronics*, May-October 1973.
 Shaw G. 'P.E. Sound Synthesiser'. *Practical Electronics*, February 1973-February 1974.
 Tünker H. 'Electronic-Pianos und Synthesiser'. *Franzis-Verlag*, 1975. Nr. 302 (RPB Serie).

from quadro to surround sound

P. Fellgett and M. Gerzon

In previous articles ('Quadrille' and 'music of the spheres', Elektor 17, September 1976, p. 910) it was noted that 'Ambisonics' was perhaps the most promising of the quadrophonic systems proposed so far. This led to a reaction from Prof. P. Fellgett, pointing out (amongst other things) that he preferred to use the phrase 'surround sound' since 'quadrophonics' rather over-stresses the number four — quite apart from being a condemnable mixture of classic tongues. Since we had very little information on Ambisonics at our disposal, we took the opportunity to ask him to write a short article explaining the basic theory and philosophy of Ambisonics. His text reached us only three weeks later (!), and it is presented here in full. Where some further comments or explanation seemed necessary, we have given this separately as an 'editorial note'. But first let us see what Prof. Fellgett has to say.

The aim of sound reproduction is to give pleasure in listening. From the earliest days of mono it was appreciated that pleasure and realism go together. Not only did the pioneers strive to extend frequency-range and reduce non-linear distortion, but they sought to refine microphone techniques to give the sense of space and depth of live music. Yet realism was still marred by lack of the sense of direction of direct and reverberant sound. Stereophony was the first step in filling this gap, and in the hands particularly of A.D. Blumlein achieved great refinement of technique, and an open transparent sense of space of great beauty. Even this was incomplete because direction could be reproduced only over a limited stage in front of the listener. The final step has been taken in the present decade by the development of surround-sound technology capable of representing direction all around the listener.

Speech, and many natural and everyday sounds, can give listening pleasure, but music is unique in its power to sustain repeated listening. The first requirement of a surround-sound system suitable for recording is therefore to sound musical. It must be able to fulfil the needs of synthesized *avant-garde* or 'pop' music, and equally to reproduce the sonorities and ambience of all the music written for performance from earliest times through baroque, classical and romantic to the present day. This requirement is symbolised in figure 1. The test is not conformity with any artefact that is a technical means to an end, such as a mixdown or a 4-track master tape. The true criterion is comparison of what the listener hears with the original live or imagined music.

The patents rights in the circuits described in this article are owned by the National Research Development Corporation.

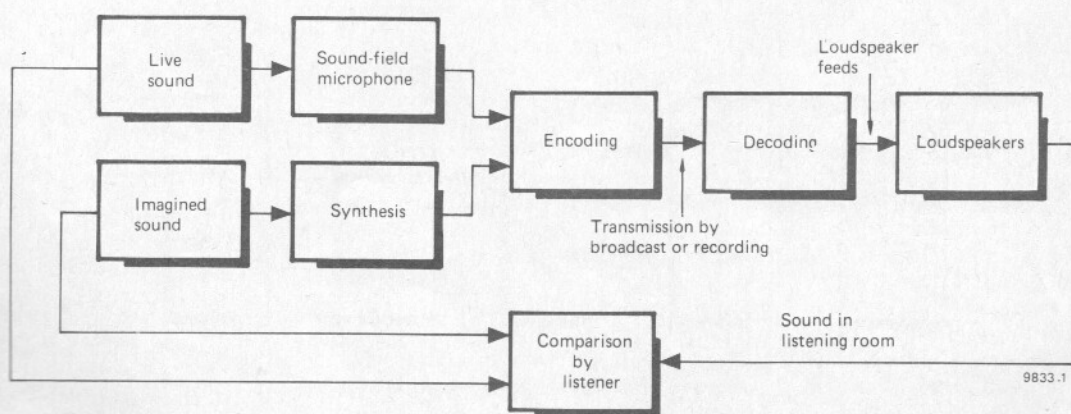
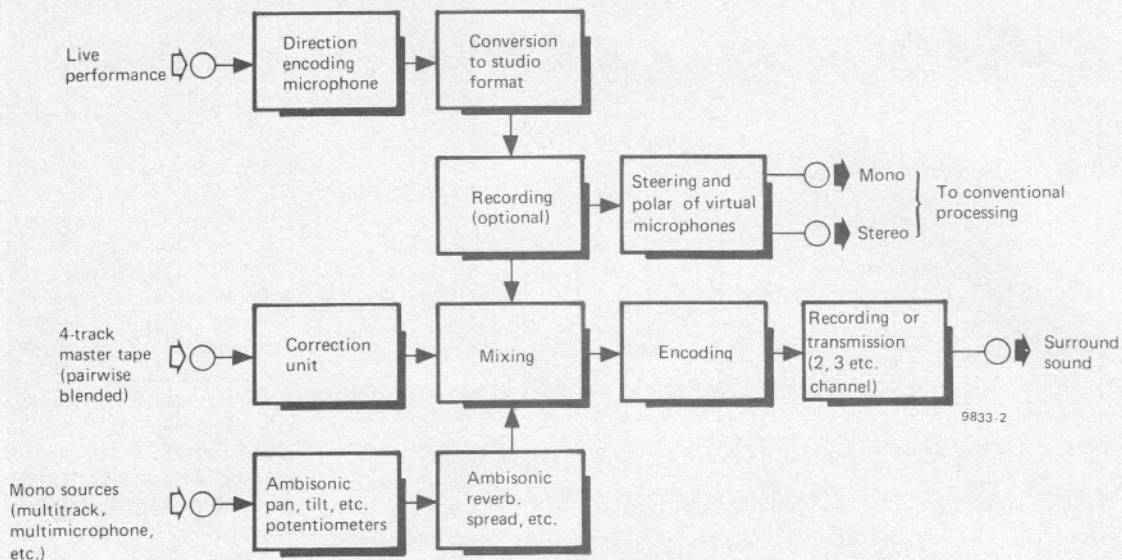
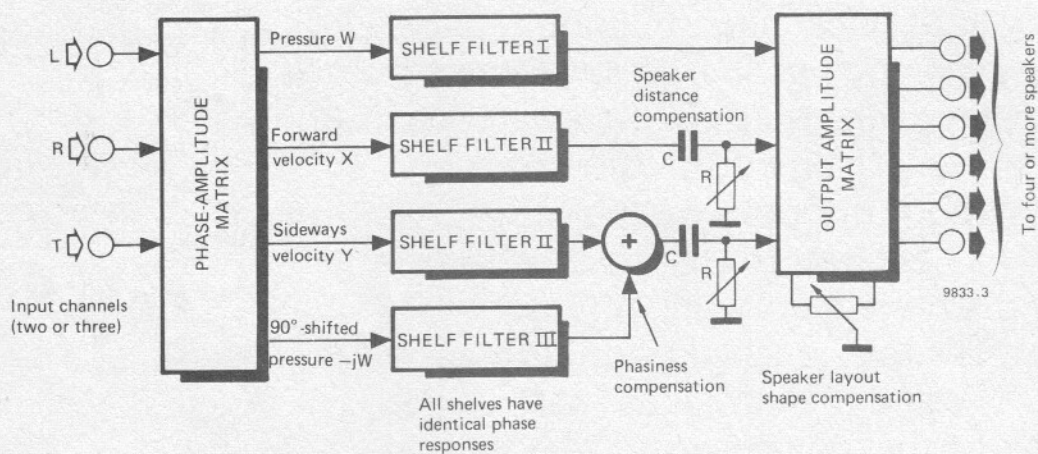

Figure 1. Block diagram to illustrate evaluation of a good surround-sound system.

2



3



4

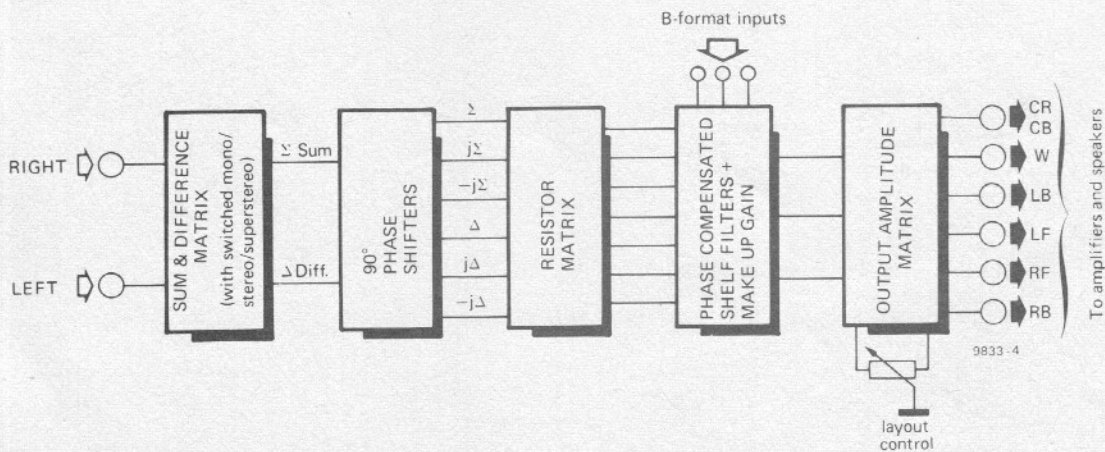

Evidently no technology can pass this test unless it can handle live performance as well as synthetic pan-pot and echo-effects. It is found that live ambient material provides the most sensitive touchstone, for musicality is quickly lost if the loudspeakers are audible as separate sources of sound, or if ambience pools in particular directions instead of being smoothly distributed. The real problem is to leave the listener undisturbed by obtrusion of the technical means of radiating sound into his room. If this can be solved, it follows almost automatically that a wide range of synthetic effects, from the simplest to some of great subtlety, can be made available by artificial simulation of elements from the response to natural ambient sound.

The purely engineering requirements are also exacting. To be acceptable today, a technology for surround-sound must cover all essential needs from studio to listener. It must provide for the variety of microphone techniques and artificial processing, and be compatible with all valid philosophies and aims of recording. It must provide a compatible series of means of transmission beginning with a basic 2-channel implementation suitable for dissemination by existing stereo media (disc, tape, fm) and, extending to it, effective use of multi-channel media. Very desirably it should enable the basic version to be enhanced by adding a third channel of reduced bandwidth or amplitude suited to carrier-disc or enhanced fm stereo broadcasting. The base-band signals must have good mono and stereo compatibility. The listener should not be restricted to having his loudspeakers in a square (a shape to which few domestic rooms are suited), and he should have freedom to enhance his system by using more than four loudspeakers if he wishes.

Figure 2. Some facilities in ambisonic technology.

Figure 3. Block diagram of a generalised ambisonic decoder (courtesy MAG).

Figure 4. Block diagram of a domestic ambisonic decoder of medium complexity for 2-channel (45JB) material. This will accept 2-channel or 3-channel B-format inputs and deliver mono, stereo, superstereo or 45JB decoded outputs. It can drive rectangular or regular hexagon loudspeaker layouts via 3 or 4 power amplifiers. Loudspeaker distance and psychoacoustic compensation are provided.

It goes without saying that any design which is free from compromise is over-engineered. A most important requirement is a body of theory competent to show how specific design aims can be realised in a minimal design, and to enable rational engineering choices to be made in accordance with stated priorities among competing requirements.

The earlier so-called 'quadrophonic' proposals for surround-sound fell short of fulfilling many of these demands, and indeed made no attempt to meet some of them. They were conceived before sufficient systematic understanding was available to avoid arbitrary choices, and a proliferation of mutually incompatible systems resulted. A new approach was needed.

Second generation surround-sound

The first of the new generation of surround-sound systems commercially available was the UMX system developed by Professor D. Cooper (University of Illinois) and Dr. Shiga of the Nippon Columbia Company, who marketed the system.

To this has been added extensive theoretical work and experiment carried out at the Universities of Oxford and Reading under the auspices of the British National Research Development Corporation, who hold extensive patents in many countries on the inventions which have resulted. The complete technology is called 'Ambisonics', and within it a compatible series of signal formats known as 45J (a development running number) has been internationally agreed. This engineering standard is the subject of current submissions to appropriate standards authorities in a number of countries. There is no simplistic 'secret' of Ambisonics. Its capability of high performance is due to clearly formulated engineering and aesthetic aims and a body of experimentally validated theory which places the realisation of these aims within normal methods of engineering design. Some unique features may however be especially noted.

Ambisonics is not an isolated 'system' but a comprehensive technology centering around engineering specifications of the signals for public distribution. Specification 45J includes a basic 2-channel format, designated 45JB, which is of itself a carefully designed surround-sound implementation with well formulated and balanced mono and stereo compatibility. This is the lowest member of a compatible series which includes members using 3 channels, or with a 4th channel which may convey height information for periphery (spherical surround). Particular attention has been given to fulfilling the need for '2½-channel' specifications in which the 45JB basebands are enhanced by a third channel of restricted bandwidth or amplitude suited to carrier disc or fm broadcasting.

In the studio

Ambisonic studio technology includes the soundfield microphone for natural sound, and a wide range of pan-pot, reverberation and spread effects conforming to an accurate specification. Correctly designed ambisonic pan-pots are actually simpler than pairwise 'quadrophonic' pan-pots, or can be made more versatile. Existing pairwise pan-pots can be converted by additional circuitry. There is provision for using archive material recorded in pairwise format, including a comprehensive range of choices for the producer to optimise the compromises inseparable from this inferior method of encoding direction.

A studio format, known as B-format, is recommended which facilitates processing and reduces sensitivity to small errors of amplitude or phase, especially in recording. An attraction of this format is that material held in it can be encoded at a later date into *any* reasonable surround, stereo or mono form for distribution, so the risk of obsolescence is minimised. Figure 2 illustrates some of the facilities available in ambisonic technology.

. and at home

The ear and brain do not locate sound by only one mechanism, but by many. The goodness of localisation, and the impression of naturalness and correctness of sonority and tone, are found to improve when different mechanisms agree. Ambisonic decoders are designed to give correct localisation by as many spectral (frequency domain) and bi-spectral (first order non-linear) mechanisms of the ear as possible. Decoders for 45JB include a 'front preference' option to cater for material in which frontal sources are predominant. Any number of loudspeakers in any layout (within reason) can be used. Decoders for four loudspeakers include 'layout' and 'distance' controls permitting adjustment for the ratio of length to breadth of rectangular layouts, and for size of room. Decoders can be provided for trapezoidal layouts, or for five, six or even more loudspeakers if wished. The inter-relations between loudspeaker feeds demanded by psychoacoustic criteria produce the useful bonus that four loudspeakers can be fed from only three power amplifiers, or six loudspeakers from four amplifiers. Since the mechanisms of the ear, and therefore the psychoacoustic criteria, change with frequency, all decoders (except the most basic for the lower end of the market) employ special phase-compensated shelf filters. This frequency-dependence improves not only localisation but also the subjective tonal quality in comparison with naive decoders lacking this feature. Loudspeaker emphasis and signal-dependent gain devices can be incorporated in ambisonic decoders for those occasions when a more gross effect may be deliberately sought. Ambisonic

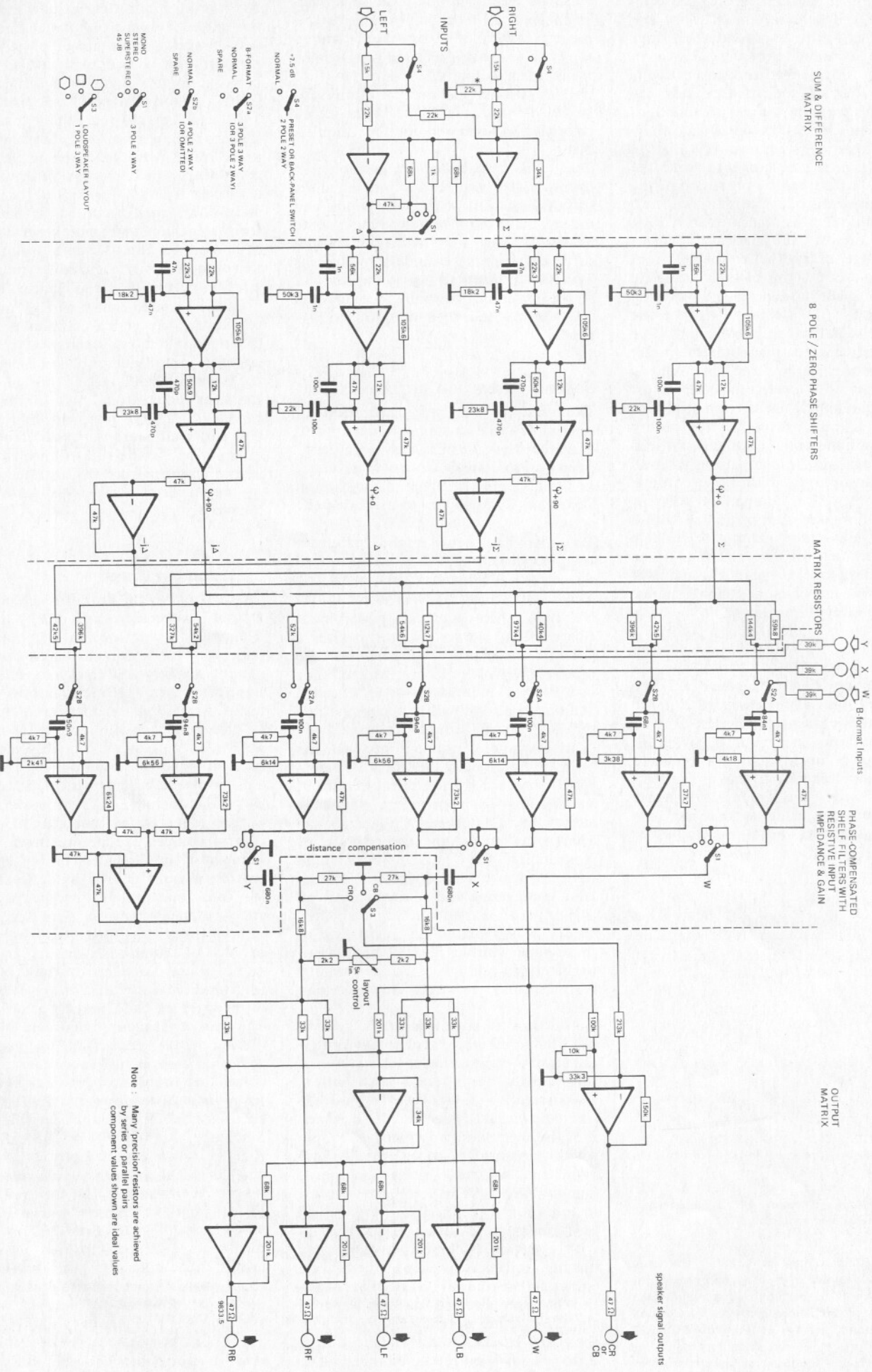

MONO STEREO 45 dB
 STEREO STEREO 45 dB
 3 POLE 4 WAY
 1 POLE 3 WAY
 LOUDSPEAKER LAYOUT

8-FORMAT 3 POLE 3 WAY
 NORMAL 10H 3 POLE 2 WAY
 SPARE 10H 3 POLE 2 WAY
 4 POLE 2 WAY
 3 POLE 2 WAY
 4 POLE 2 WAY
 3 POLE 2 WAY
 4 POLE 2 WAY
 3 POLE 2 WAY

7.5 dB PRESET ON BACK-PANEL SWITCH
 NORMAL 2 POLE 2 WAY
 1 POLE 2 WAY

PHASE COMPENSATED SHELF FILTERS WITH RESISTIVE INPUT IMPEDANCE & GAIN

distance compensation

OUTPUT MATRIX

Note: Many 'precision' resistors are achieved by series or parallel pairs
 Component values shown are ideal values

speaker signal outputs

45J-encoded material can if wished even be played through the Sansui 'Variomatrix' decoder, with simple added circuitry. An ambisonic decoder with signal-dependent gains has been designed having improved conformity with psychoacoustic requirements. Figure 3 is a block diagram illustrating a generalised ambisonic decoder; of course not all of the features need be present in a particular consumer product.

These features of ambisonic decoders are more or less realisable (by suitable modifications of circuitry) with source material encoded in any reasonable way, although best results require correct 45J (or equivalent) encoding. BBC 'Matrix H' encoding is close enough to 45JB to be playable directly into ambisonic 45J decoders with psychoacoustic enhancement of performance. There is effective compatibility with Nippon Columbia 'Denon' UMX, and a simple switching enables RM, QS and SQ material to be handled with a degree of approximation depending on the source encoding. A 'stereo decode' mode is available. This does not deliberately give a synthetic pseudo-surround effect, but enables localisation in the frontal stereo stage to be improved by the use of four (or more) loudspeaker playback.

Figure 4 is a block diagram of a domestic decoder of medium complexity for 2-channel (45JB) material. The blocks are expanded into actual circuit configurations in figure 5 and these are in turn shown in more detail in figure 6 (a), (b), (c) and (d). Figure 7 shows various ways of using the outputs for four or six loudspeakers using three or four power amplifiers.

Decoder functions

The decoder circuit given here has a four-position mode switch, labelled 'mono', 'stereo', 'superstereo' and '45JB'. It should be noted that the 'mono' and 'stereo' positions are not obtained by simply switching off unwanted channels or shorting outputs together.

Mono reproduces mono material through 4 or 6 loudspeakers so that the sound image appears to be straight ahead, but at a larger distance than the speaker distance. It avoids the 'coming from a box' effect of single-speaker mono reproduction, and the 'in-the-head' and tone-colour distortions associated with 2-speaker mono reproduction. In practice, 'mono' decode helps unlock the spacious quality contained in good mono recordings.

Stereo reproduces conventional stereo material over the conventional front-quadrant stereo stage, but uses the extra speakers to reduce undesirable qualities of 2-speaker stereo reproduction - notably excessive speaker prominence, unstable images and tone-colour distortions. 'Stereo' decode does not enhance the quality of badly-recorded stereo material (but neither does it

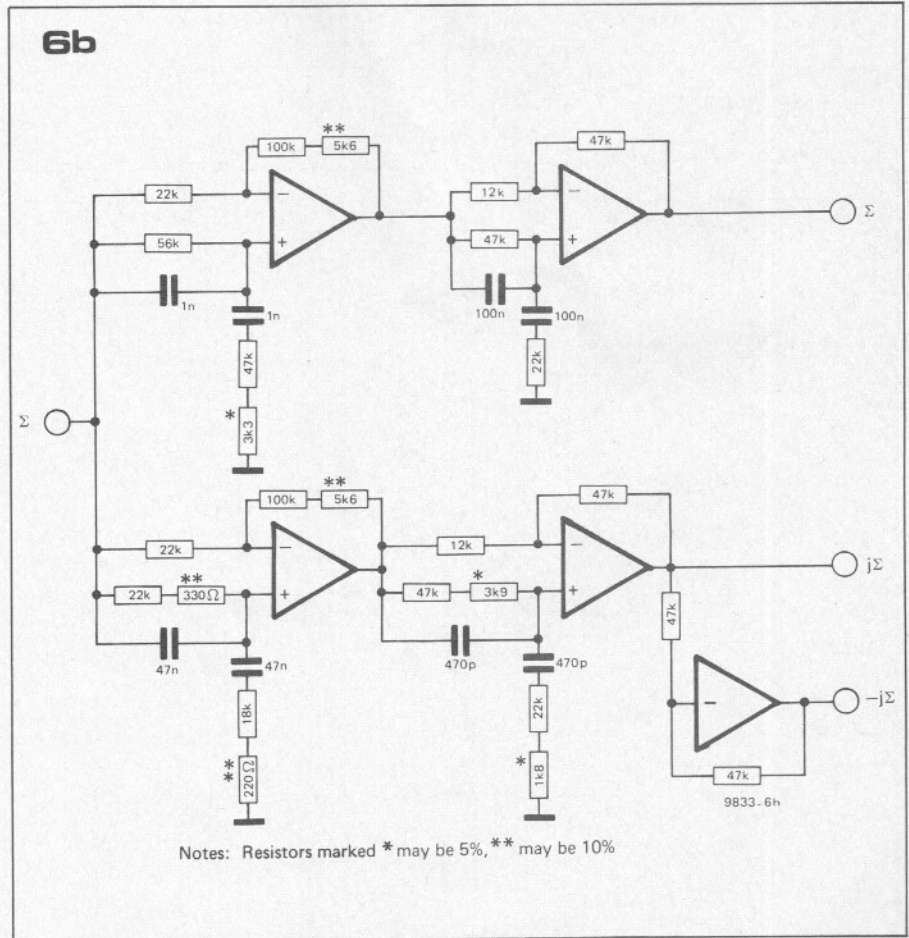
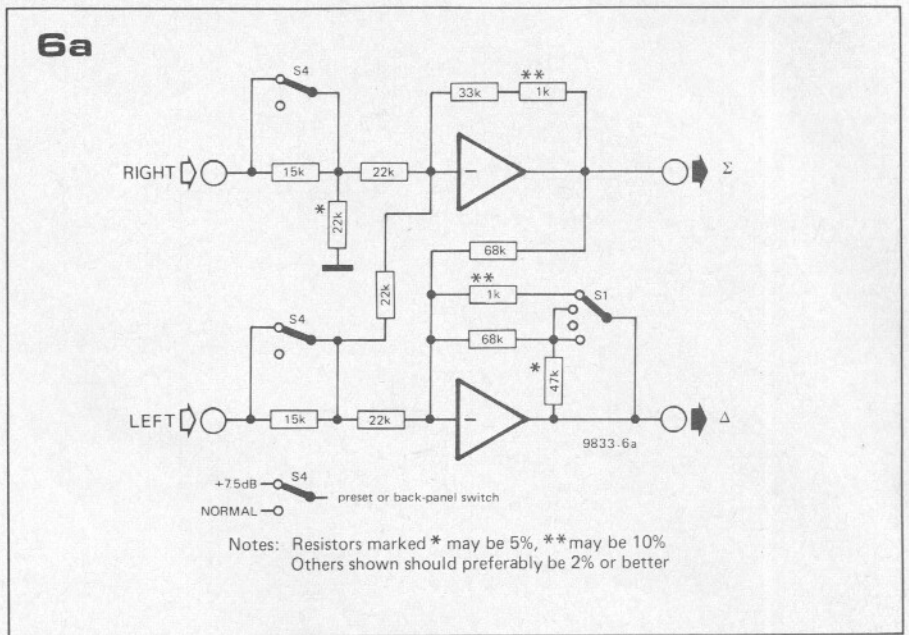

Figure 5. Overall circuit diagram of domestic ambisonic decoder corresponding to the block diagram of figure 4.

Figure 6a. Detailed circuit of input stages (sum/difference matrix).

6b. Detailed circuit of phase shifter stage. Two of these stages are required, one for the Σ and one for the Δ signal. Nominal performance: phase shift 90° ± 1 1/3° from 30 Hz to 16 kHz. A 2% component spread gives 90° ± 3° over this range. Stage gain is 1.33 dB.

worsen it). Good material will obtain a further sense of spaciousness without any gimmickry of directional effect. The effect is almost completely unobtrusive and yet capable of considerable reduction of listener fatigue through presenting the ears with a more natural sound. 'Stereo' decode also tends to enhance the reproduction of SQ-encoded records.

Superstereo gives a wider frontal stage from stereo material for those who wish for a more spectacular effect, without descending to mere gimmickry. This position also provides excellent decoding

6c

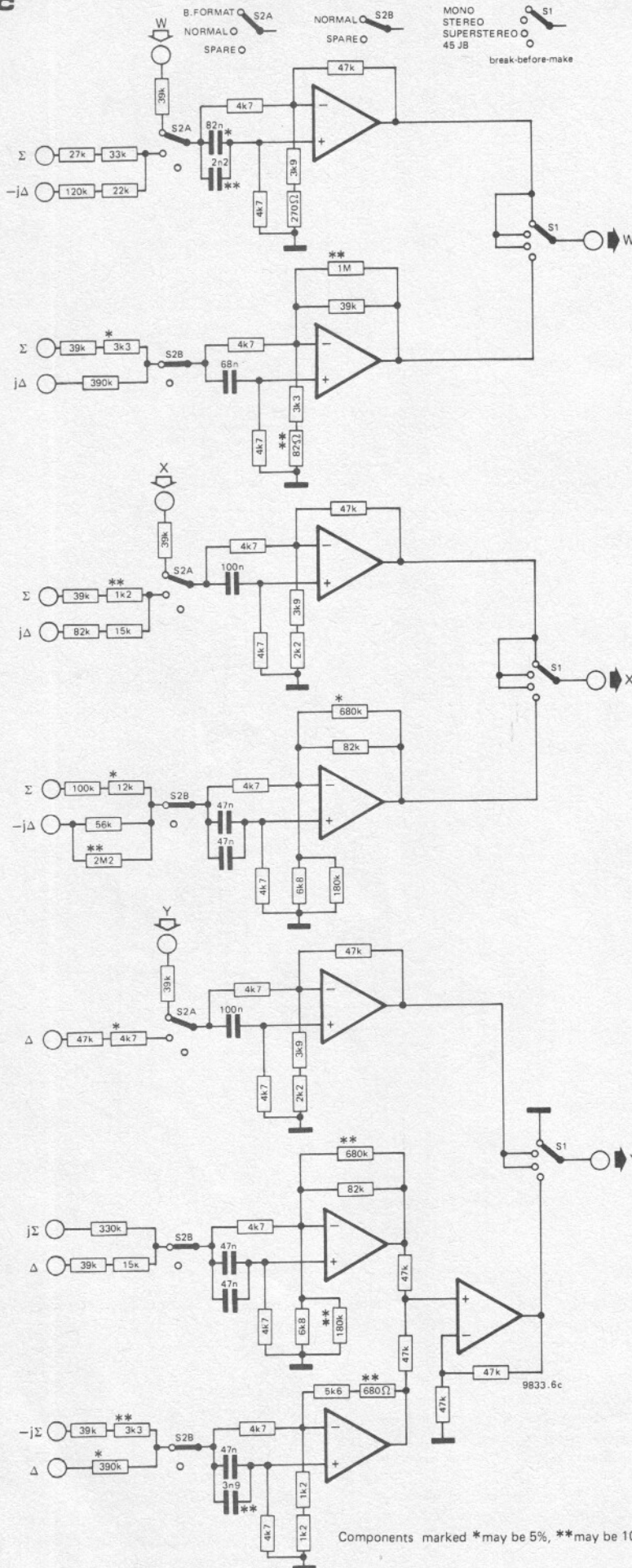

of Regular Matrix encoded records, with a full 360° reproduced stage. 45JB decodes system 45J recordings and broadcasts. It is also suitable (but not optimised) for decoding 'Matrix H' for good ambient reproduction, and it is reasonably compatible with BMX recordings. B-format enables those with a 4-channel recorder to get optimal studio-quality reproduction from master recordings made in the ambisonic B-format studio mode.

Editorial notes.

Let's be honest: we are impressed by the capabilities of ambisonics. To sum it up briefly:

- an ambisonic system will accept practically any input.
- an ambisonic system makes the fullest use of the available number of transmission channels.
- an ambisonic system can drive almost any loudspeaker layout, using a minimum number of power amplifiers.
- the designers of ambisonics have evidently done their homework.

Great!

Now let's be practical. At the moment, no ambisonics recordings are commercially available. There is very little point in building an ambisonics decoder until some record company starts supplying these recordings, or until some broadcasting corporation starts transmitting in ambisonics. From a technical point of view (please note: *not* necessarily a commercial or even a consumer point of view) we wish that this situation were different.

In theory, and even — as we have heard on first-hand authority — in practice, a surround-sound demonstration using ambisonics is unbelievably convincing. Speaking only from the theoretical point of view, we are prepared to go along with this: we have favoured UD-4 so far, since this system seemed to make full use of the available transmission capabilities. In our opinion, ambisonics is an extension of UD-4: technology and mathematics have been complemented with psycho-acoustic research. We have tried to give all systems an equal chance in the pages of this magazine, and we have noted the good points of each system. In previous articles we have even noted that there may be room for more than one system. However, if only one system is to be chosen for universal application, our money is on ambisonics — on a purely technical and theoretical basis. We can't wait to hear a practical demonstration!

Finally, some comments on this article. It is, of course, incomplete. It is sufficient to whet the appetite — without giving something to bite on. The author explains that they are still negotiating with various parties and cannot release more information.

The circuits are quite basic, but they are approved by the inventors. There are no alignment points, to our relief, so we don't need to give alignment instructions. So long as there are no commercial releases of ambisonic recordings, we do not feel obliged to offer a printed circuit board.

For that matter, Mr. Gerzon (who designed this decoder within 48 hours!) has pointed out that there is room for improvement and simplification. When the time seems ripe for a constructional article with a p.c. board, we hope to take him up on this. However, the circuit shown here does give an idea of what an 'ambisonics' decoder looks like, and that is sufficient for the present.

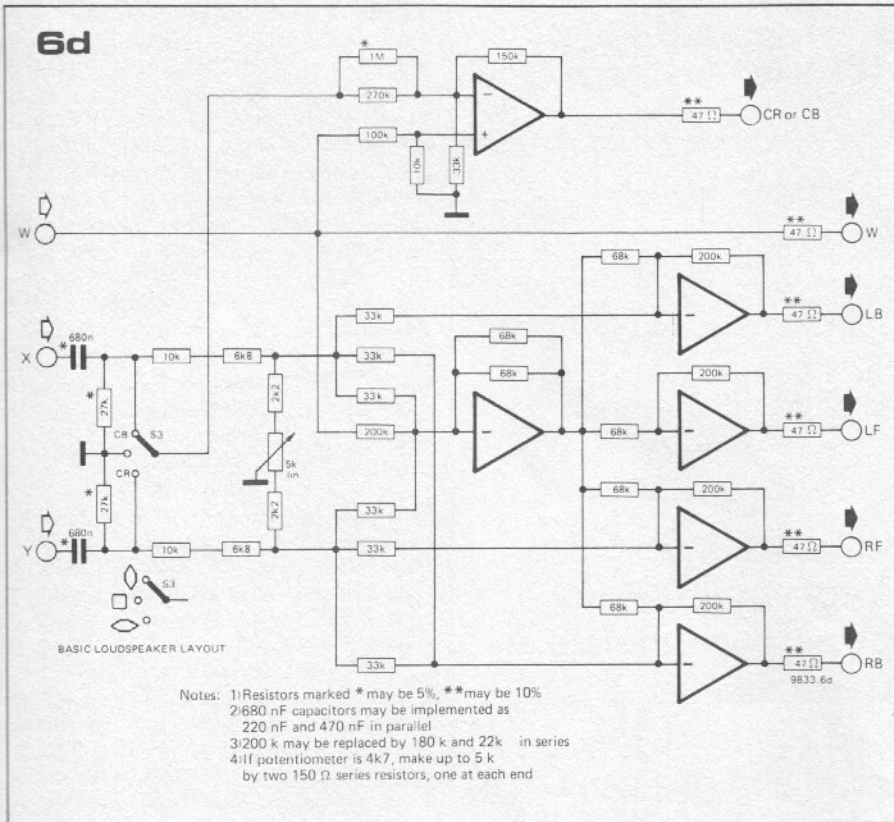
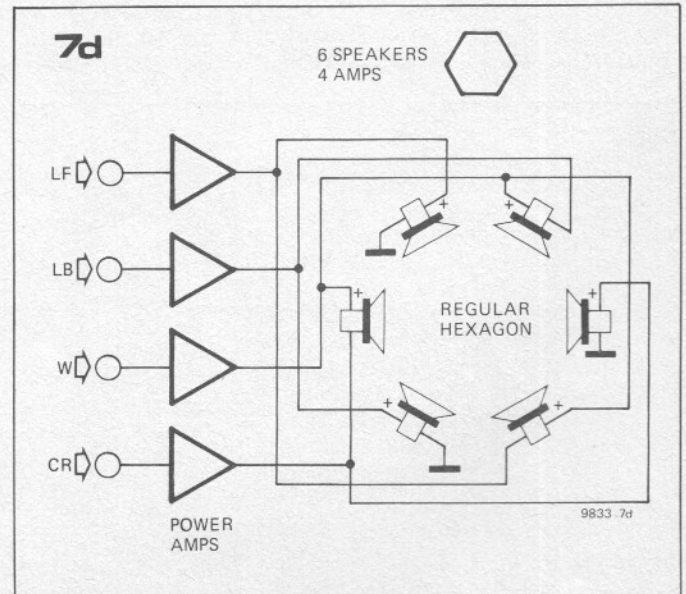
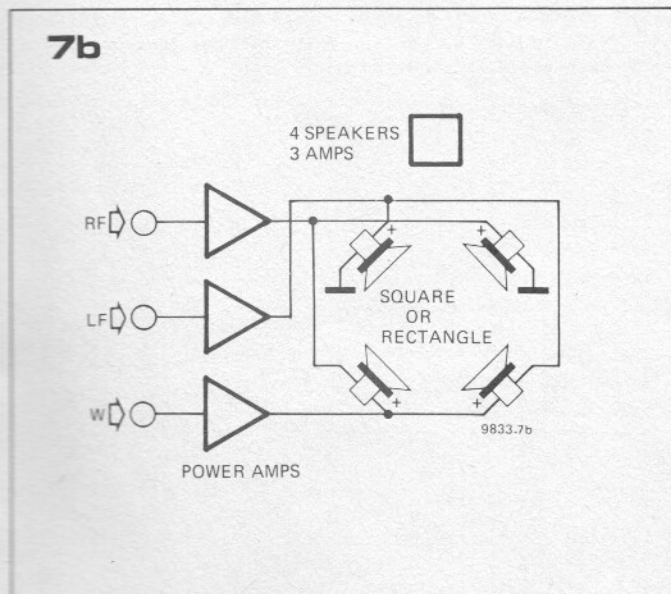
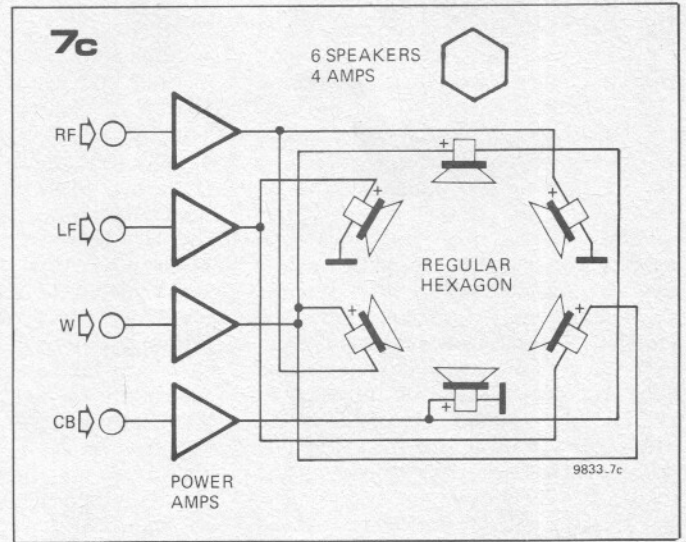
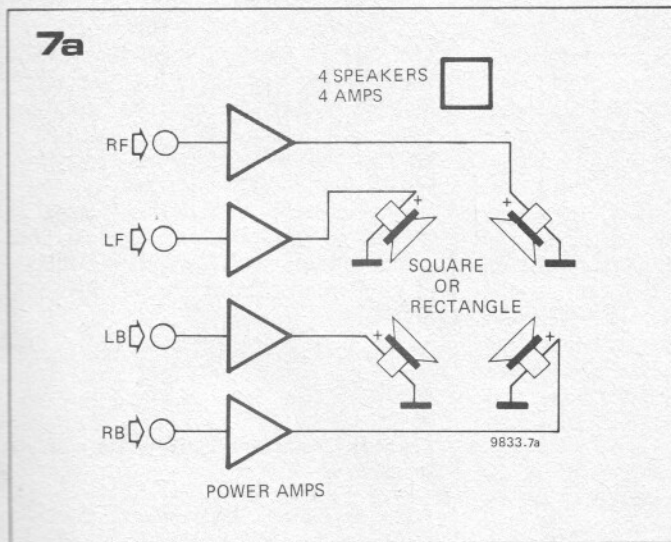

Figure 6c. Detailed circuit of resistor matrix + shelf filter stage.

Figure 6d. Detailed circuit of output stages, including loudspeaker distance compensation, loudspeaker layout control and amplitude matrix.

Figure 7. Three or four of the outputs from figure 6 may be fed to power amplifiers to drive four- or six-loudspeaker layouts. The '+' sign indicates the positive loudspeaker terminal in each case.



stereo encoder

A. Bosschaert

This relatively simple circuit will combine two independent audio signals into a multiplexed stereo signal similar to that used to modulate an FM transmitter for stereo transmissions. It can, amongst other things, be used to check the operation of stereo decoders in FM receivers.

To those unfamiliar with stereo FM transmissions 'multiplex encoding' and 'decoding' may seem a little mysterious. The immediate answer to the problem of transmitting a stereo signal would seem to be to transmit the left signal on one FM channel and the right signal on an adjacent FM channel. However, this solution is unattractive for several reasons, for one thing it would occupy two FM transmitters to send out one programme, and two receivers would be required to receive it. Nevertheless, experiments on these lines were carried out, and occasionally are still carried out for quadrophonic transmissions, the front channels being transmitted by one transmitter and the rear channels being transmitted by another.

For a practicable system, some method had to be found of modulating both left and right signals on to a single transmission in such a manner that they could be separated at the other end.

This is where the concept of frequency multiplexing comes in. The next obvious step would be to modulate say the left signal direct onto the FM carrier, but the other signal would first be amplitude modulated onto a high-frequency subcarrier which itself was modulated onto the carrier along with the left channel audio signal. In the receiver the total FM signal would be demodulated to give the left channel plus modulated subcarrier. Lowpass filtering to remove the subcarrier would then give the left signal, while highpass filtering to remove the left channel plus AM detection would yield the right signal.

This idea unfortunately falls down on mono compatibility, since people equipped with only a mono receiver would be able to receive only the left channel! Since the majority of listeners possess only mono receivers the broadcasting authorities are very keen on the

subject of mono compatibility. Since the total mono signal is the sum of the left and right signals it seems logical to modulate the mono or L + R signal direct onto the carrier. This is identical to a mono transmission and is thus fully mono compatible. To separate the left and right signals in a stereo receiver it is then necessary to modulate the difference between the two signals (i.e. L - R) onto the subcarrier. At the receiver, having demodulated the FM signal and the subcarrier to give the L + R and L - R signals, the L and R signals can be retrieved by performing two simple algebraic operations i.e.

$$L = \frac{1}{2} ((L+R) + (L-R))$$

$$R = \frac{1}{2} ((L+R) - (L-R))$$

This is the basis of the GE-Zenith multiplex stereo system, which has been universally adopted for FM stereo transmissions. A mono receiver will, of course, demodulate only the L + R signal, the modulated subcarrier being rejected by a lowpass filter in the receiver.

Figure 1a shows the frequency spectrum occupied by a multiplex stereo signal. The L + R signal occupies the normal audio spectrum from 30 to 15 kHz. The L - R signal is amplitude modulated onto a 38 kHz subcarrier and so occupies two sidebands extending 15 kHz above and below this frequency. The 38 kHz carrier is itself suppressed, but in order that it can be regenerated at the receiver for demodulation purposes a low level 19 kHz pilot tone is transmitted, which is phase-locked to the original 38 kHz subcarrier.

Figure 1b shows how the L - R signal is modulated onto the subcarrier. In this example the L and R signals are shown as simple sinusoidal signals of 2 kHz and 4 kHz.

Figure 1a. Spectrum of a multiplex encoded stereo signal.

Figure 1b. Showing modulation of the L - R signal onto the 38 kHz subcarrier.

Figure 2. Pre-emphasis of the signal above 3 kHz improves the high-frequency signal-to-noise ratio.

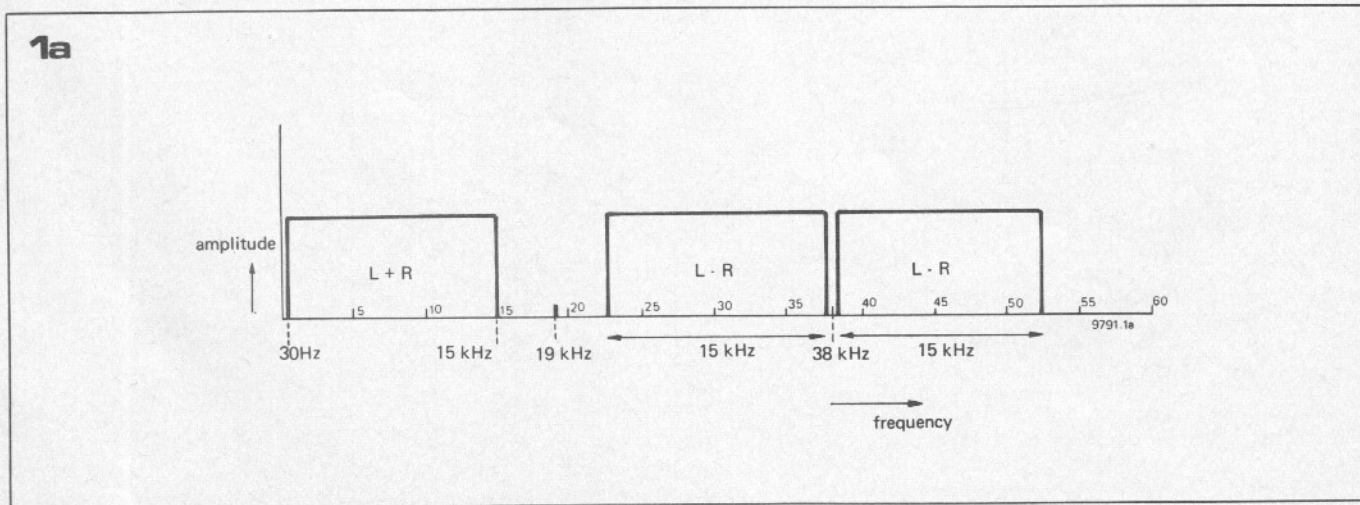

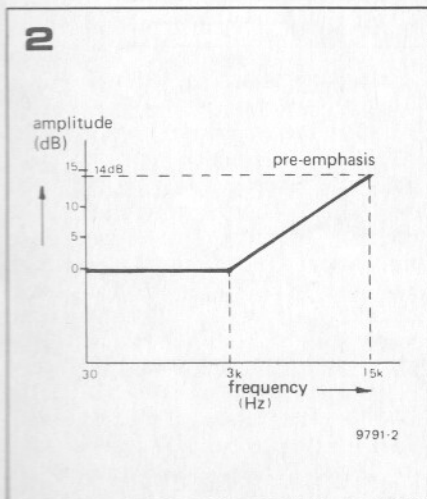
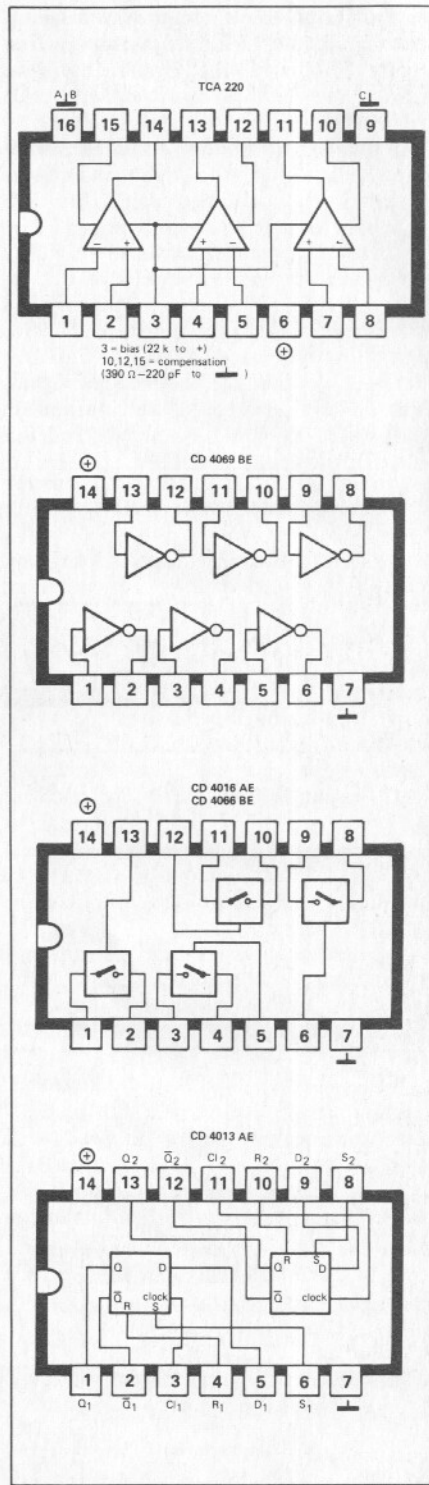
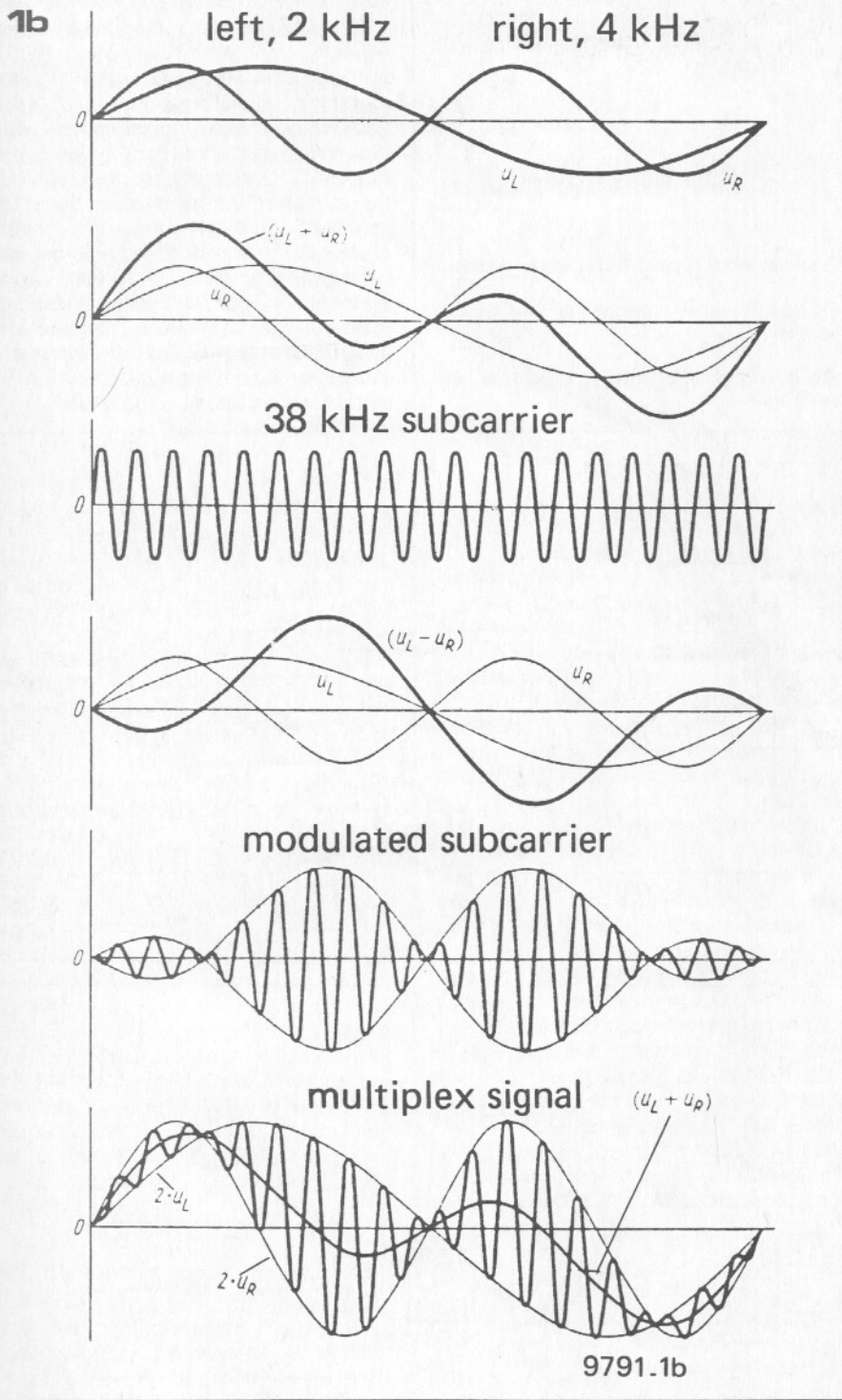

Pre-emphasis and De-emphasis

It has long been known that most of the energy content of naturally produced audio signals, including speech and conventional musical instruments, occurs below about 3 kHz. If an audio signal were frequency modulated onto a carrier with no processing then, because of the lower amplitude of high-frequency signals, the signal-to-noise ratio would tend to be worse at the top end of the audio spectrum. For this reason signals above 3 kHz are boosted or given a pre-emphasis before the audio signal is modulated onto the carrier. The pre-emphasis curve is given in figure 2 and is simply a 6 dB/octave lift above 3 kHz up to 15 kHz (for European Broadcasts).

Pre-emphasis is generally quoted as the time constant of the RC network necessary to produce the required pre-emphasis curve. In Europe pre-emphasis of 50 μ s is used, while in the USA 75 μ s is the standard.

At the receiver, in order to produce a flat audio frequency response, a de-emphasis network must be employed having an inverse characteristic to the pre-emphasis network, i.e. a fall of 6 dB/octave above 3 kHz. This network comes after the stereo decoder, so in fact each channel has its own de-emphasis network.

Block diagram of the encoder

Having examined the composition of the multiplex signal it is now possible to

formulate the requirements for a stereo encoder, and a block diagram is given in figure 3. Firstly, the L and R signals must be fed through pre-emphasis networks to boost the high frequencies. The two signals are then summed to give the L+R signal, the right channel is inverted and summed with the left channel to give the L-R signal. The 38 kHz subcarrier is derived by dividing down the output of a 76 kHz oscillator, the division process ensuring a waveform with a 1:1 mark-space ratio. The 19 kHz pilot tone is similarly derived by dividing the 38 kHz signal. The 38 kHz subcarrier is then amplitude modulated by the L-R signal, and the

modulated subcarrier, pilot tone and L+R signal are summed together before being fed to an output amplifier. It should be stated at this point that the multiplex signal produced by this encoder does not comply exactly with broadcast regulations. For one thing sinusoidal waveforms are specified for the subcarrier and pilot tone. Since the encoder described here uses digital division the waveforms produced are squarewaves. However, the signal generated is quite adequate for simple testing of stereo decoders, and the cost of an encoder to the full official specifications would hardly be justified for the home constructor.

Figure 3. Block diagram of the stereo encoder.

Figure 4. Complete circuit of the stereo encoder.

Figure 5. Pinouts of the IC's used in the encoder.

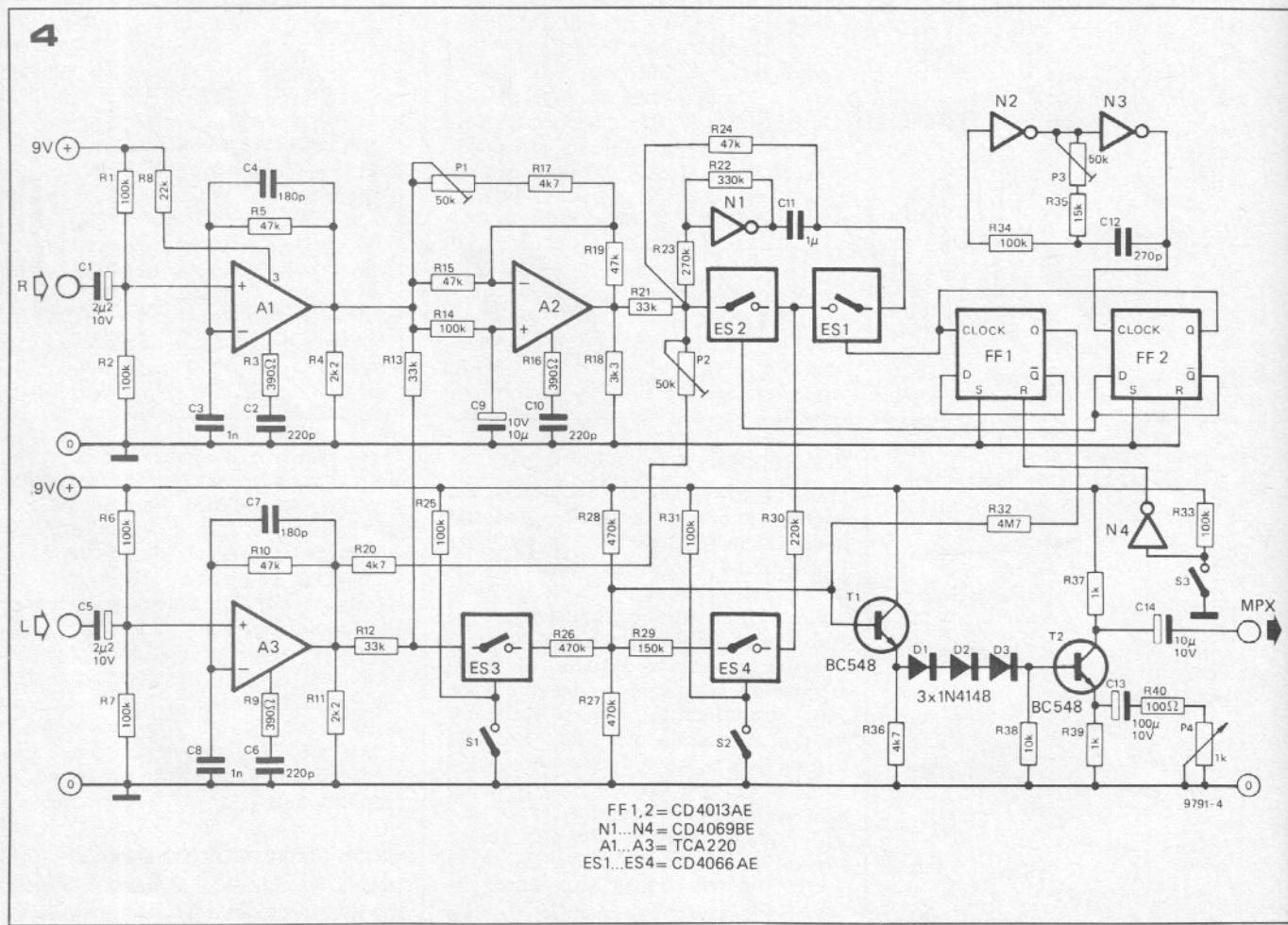
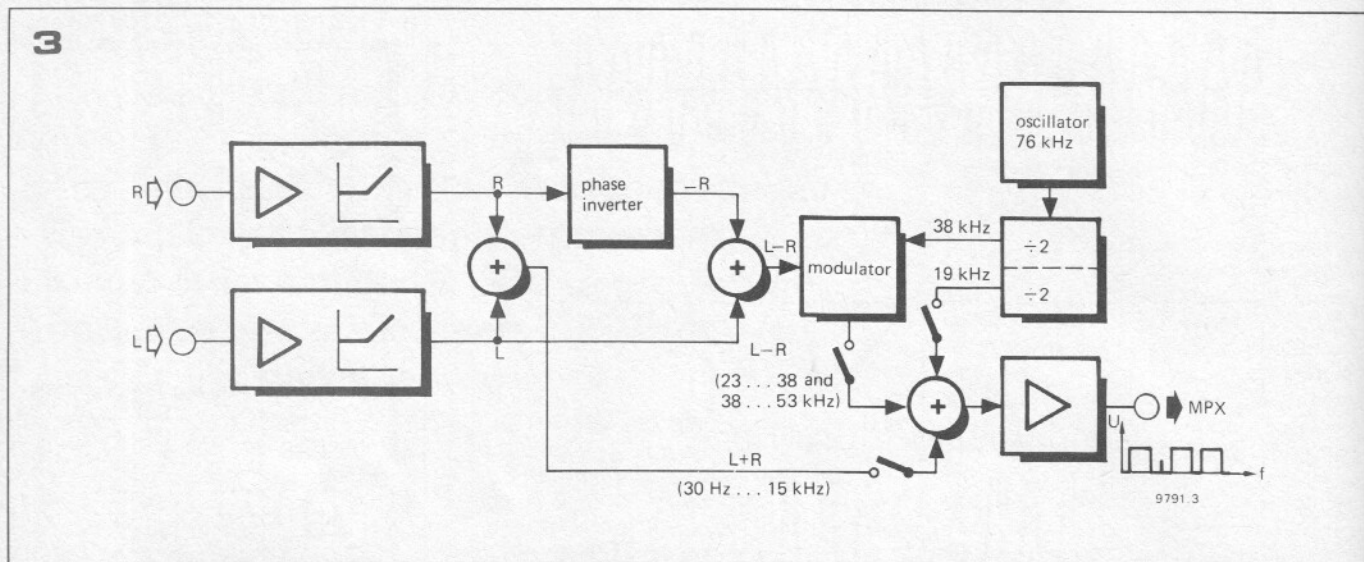

Complete Circuit

The various functional blocks of the circuit can easily be identified in the complete diagram of figure 4. A1 and A3 operate as input buffer amplifiers having unity gain below 3 kHz. Above 3 kHz the feedback networks R5/C3 and R10/C8 provide the rising pre-emphasis characteristic. The outputs of A1 and A3 are summed by R12 and R13 before being fed to an electronic switch ES3, which can be used to switch the L+R signal in and out.

The R signal is inverted by A2 and the L and -R signals are summed by R21, R20 and P2. With this simple summing arrangement there exists the possibility of crosstalk, but this can be minimised by the adjustment of P1 and P2.

The 76 kHz oscillator is constructed around two CMOS inverters N2 and N3, the frequency of oscillation being adjustable by P3. If desired C12 could be replaced by a 76 kHz crystal to improve the oscillator frequency stability, but this expense is probably not justified. Two CMOS flip-flops FF1 and FF2 divide down the 76 kHz signal to provide the subcarrier and the pilot tone. S3 can be used to inhibit the pilot tone by disabling FF1.

Since the subcarrier must be completely suppressed a balanced modulator is employed. This consists of two electronic switches ES1 and ES2, part of a 4066 IC, and a CMOS inverter N1, connected as an inverting linear amplifier.

The modulator output passes through another electronic switch ES4, which can be used to switch in and out the modulated L-R signal by means of S2. The L+R signal, modulated L-R signal and pilot tone are all summed at the base of T1, T1 and T2 acting as an output buffer amplifier to provide a low output impedance. P4 adjusts the gain of T2 and hence the amplitude of the multiplex signal.

Adjustment

To check the operation of the encoder, first set the oscillator frequency to 76 kHz using a frequency counter, then adopt the following procedure.

1. With only the L+R signal switched in, connect the encoder output to the external input of an FM test generator and use P4 to adjust the deviation.
2. Connect the generator output to a properly aligned FM receiver, tune to the generator frequency and switch in the pilot tone and L+R signals. The stereo beacon on the tuner should light.
3. Alternately switch off the left and right channels and adjust P1 and P2 for maximum separation, i.e. with left signal applied adjust for minimum output from the right channel and vice versa.
4. Alternatively the multiplex signal can be fed direct to a stereo decoder. P4 should be adjusted so that the multiplex signal level is within the operating range of the decoder. Then follow procedure 3.

precision v to f converter

Although this Voltage Controlled Oscillator uses only two CA3130 op amps the linearity of its voltage/frequency transfer characteristic is better than 0.5% and its temperature coefficient less than 0.01%/°C.

The circuit operates as follows: IC1 functions as a voltage controlled multivibrator. Assuming that the output voltage of IC1 is initially +15 V, C1 will charge via D3, R4 and P1 with a time constant (R4 + P1) C1 until the voltage on the inverting input of IC1 exceeds that on the non-inverting input. Neglecting D1 and D2 for a moment this is approximately 10 V, set by the potential divider R1, R3 and R2. The output of IC1 will now swing down to zero and the voltage on the non-inverting input will fall to about 5 V due to the hysteresis introduced by R3. C1 will now discharge into the output of IC2 at a rate determined by R7 and the output voltage of IC2 until the voltage on the inverting input of IC1 falls below 5 V, when the output of IC1 will swing up to +15 V again and the cycle will repeat. The output waveform of IC1 thus consists of a series of positive

pulses whose duration (T2) is a constant and whose spacing (T1) depends on the output voltage of IC2.

The output voltage of IC1 is filtered by R6 and C3 to give a DC voltage (V2) equal to the average value of the IC1 waveform i.e.

$$V_2 = 15 \times \frac{T_2}{T_1}$$

Since T2 is constant V2 is proportional to 1/T1 i.e. proportional to the output frequency of IC1.

The input voltage V1 is applied to the inverting input of IC2, which functions as an integrating comparator. If V1 is less than V2 the output of IC2 will ramp positive. C1 will thus discharge at a slower rate, making the interval T1 longer and reducing V2. If V1 is greater than V2 then the output of IC2 will ramp negative (i.e. towards zero) making C1 discharge more quickly and reducing T1. When V1 and V2 are equal the output voltage of IC2 will remain constant.

The circuit will thus always reach equilibrium with V1 = V2. However, since V2 and the output frequency of IC1 are proportional then the output frequency of IC1 is also proportional to the input voltage V1, since V1 and V2 are equal.

A few small refinements are added to improve the temperature stability of the circuit. The temperature coefficients of D3 and D4 could introduce errors by varying the charge and discharge times of C1, so these are compensated by including identical diodes in series with R3 to produce a similar variation in the reference voltage at the non-inverting input of IC1.

P2 is included to null the offset voltage of IC2 which would otherwise cause a zero error.

P1 provides fine adjustment of the conversion ratio, which with the values given is about 1 kHz/volt.

Lit.: RCA Application Notes.

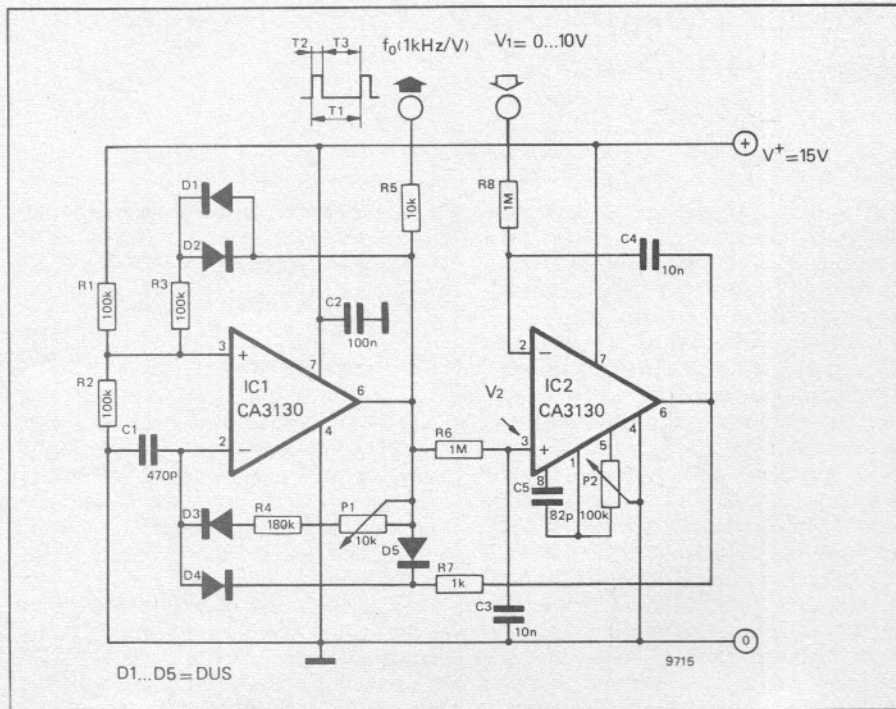



slotless model car track

(2)

As described in last month's article, the model cars are powered from the special race track, but steering and speed commands are provided by an infra-red communication link. The speed and direction of up to four cars can independently be controlled using a 9-channel time-division multiplexed 'digi-proportional' control system. This month's article describes the circuit of the multiplex encoder, and the principle of the decoder. The board layout for the infra-red transmitter will also be given.

Last month it was described how, in a digi-proportional control system, the position of servo's was proportional to the width of a rectangular control pulse. The range of pulse width chosen was 1...2 milliseconds so that, for example, the extreme left position of the steering servo corresponds to a pulse width of 1 ms, the extreme right position to 2 ms, and the centre position to 1.5 ms.

Since several servo's are to be controlled the control pulses for each servo are time division multiplexed into a pulse train. A particular pulse in the train corresponds to a particular servo, and the width of each pulse can be independently controlled. The multiplex encoder must be capable of producing the different pulses to control each servo and assembling them into a pulse train

in the correct sequence. The multiplex decoder at the receiving end must be capable of 'picking out' each pulse and feeding it to the correct servo amplifier.

Multiplex encoder

The multiplex encoder uses circuits that will be familiar to the experienced constructor, namely, an astable multivibrator to generate clock pulses to control the whole sequence, monostable multivibrators to produce the control pulses and a NOR-gate to collect all the pulses into a pulse train.

For the less experienced constructor the basic circuit of an astable multivibrator is explained in figures 1a and 1b. Since an astable multivibrator is an oscillatory circuit, to understand it, it is necessary

to 'freeze' its operation at a certain point in the cycle, and to make certain assumptions. Firstly, it is assumed that R_4 is much less than R_3 and R_1 is much less than R_2 . Secondly, assume that T_1 is presently turned off, but is about to turn on (how it turns on will become apparent). Since T_1 is turned off C_1 is charged via R_1 and the base-emitter junction of T_2 to $V_b - 600$ mV. If T_1 now turns on the left hand end of C_1 will be grounded through the collector-emitter junction of T_1 , but since the voltage across C_1 cannot change instantaneously the right hand end falls to $-(V_b - 600$ mV), turning T_2 hard off. C_2 will now charge rapidly to $(V_b - 600$ mV) through R_4 and the base-emitter junction of T_1 . The large pulse of base current delivered to T_1

will turn T1 hard on, thereafter T1 remains turned on by current flowing through R2.

C1 will discharge slowly through R3 and the collector-emitter junction of T1 until the voltage on the base of T2 exceeds 600 mV, when T2 will turn on. The base of T1 will be pulled down to $-(V_b - 600 \text{ mV})$ and T1 will turn off. C1 will charge rapidly through R1 and the base-emitter junction of T2. C2 will charge slowly through R2 and the collector-emitter junction of T2 until the base voltage of T1 exceeds 600 mV, when T1 will turn on, which is where we came in.

The time for which each transistor is cut off is the time taken for C1 or C2 to charge from $-(V_b - 600 \text{ mV})$ to 600 mV, and is determined by the time constants $R3 \cdot C1$ and $R2 \cdot C2$.

The time t_1 for which T1 is turned off is given by $R2 \cdot C2 \cdot \ln 2$ and the time t_2 for which T2 is turned off is given by $R3 \cdot C1 \cdot \ln 2$, where $\ln 2$ is the natural logarithm of 2 (approximately 0.7).

Figure 1b shows the waveforms at various points in the circuit. Waveform A shows the collector voltage of T1. The base waveform of T1 is shown in B and the exponential rise from a negative voltage can clearly be seen. Waveforms C and D show the voltages on T2 collector and base.

The period of the total waveform is $t_1 + t_2$ and the frequency, being the reciprocal of the period, is

$$\frac{1}{t_1 + t_2}$$

An astable multivibrator may be made either symmetric or asymmetric i.e. with t_1 equal to t_2 or t_1 not equal to t_2 , and it may be useful at this point to introduce the concept of duty-cycle and mark-space ratio. The duty-cycle of a rectangular waveform is the time for which the waveform is positive divided by the total period times 100%. Thus the duty-cycle of the waveform at the collector of T1 is

$$\frac{t_1}{t_1 + t_2} \times 100\%$$

On the other hand the duty-cycle of the T2 collector waveform is

$$\frac{t_2}{t_1 + t_2} \times 100\%$$

The mark-space ratio of the waveform is simply t_1/t_2 , or t_2/t_1 looking at the collector of T2.

Monostable multivibrator

Unlike the astable multivibrator, which is an oscillator with no stable or 'rest' state, the monostable, as its name implies, has one stable state. It also has an unstable state into which it can be flipped by a trigger pulse, and it will return to the stable state after a preset time.

Figure 2a shows the basic circuit of a monostable. In the stable state T2 is turned on by current flowing into its base through R2. Its collector voltage is

1a

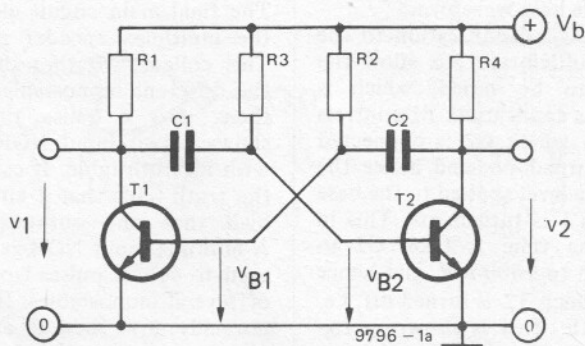

1b

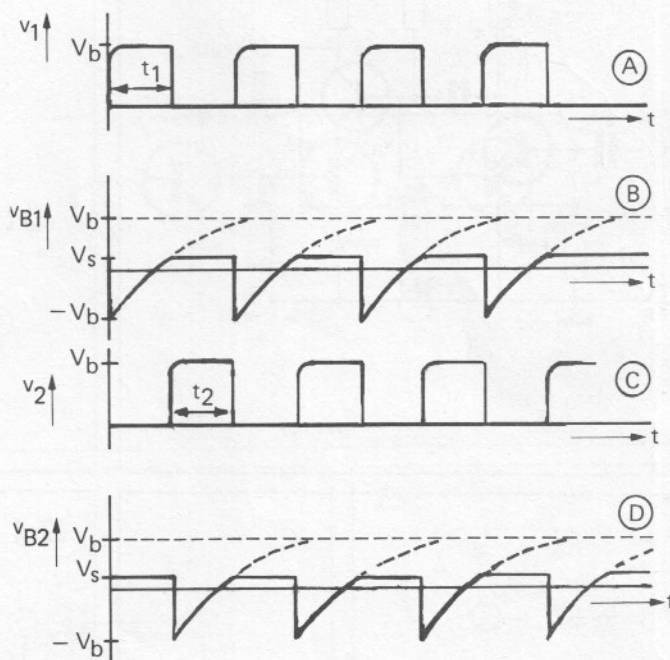

$$t_1 = R2 \cdot C2 \cdot \ln 2 \approx 0.7 \cdot R2 \cdot C2$$

$$t_2 = R3 \cdot C1 \cdot \ln 2 \approx 0.7 \cdot R3 \cdot C1$$

9796-1b

Figure 1a. Basic circuit of an astable multivibrator, used as a clock generator in the multiplex encoder.

Figure 1b. Waveforms at various points in the astable circuit.

almost zero so the base of T1 is grounded and T1 is turned off. C2 is charged to $(V_b - 600 \text{ mV})$. If a short positive pulse is applied to the base of T1, T1 will turn on, grounding the left hand end of C2. The right hand end of C2 will take the base of T2 negative, turning off T2. The collector voltage of T2 will rise and T1 will be kept turned on by current flowing into its base through R4, even after the trigger pulse has disappeared. T2 will remain turned off until C2 has charged via R2 and the collector-emitter junction of T1 to +600 mV, when T2 will turn on again and T1 will turn off.

The time for which T2 is turned off is exactly the same as for the astable multivibrator i.e. $R2 \cdot C2 \cdot \ln 2$.

Figure 2b shows the various waveforms

in the monostable circuit. Waveform A represents the trigger pulse and B shows the base voltage of T1. Waveform C is the collector waveform of T2 and waveform D the base waveform. Figure 2c shows a modification to the monostable multivibrator to allow the pulse width to be varied, which is essential in this application. P1 controls the voltage to which C2 is connected while T1 is turned on, and hence the negative voltage level applied to the base of T2 when T2 is turned off. This in turn varies the time it takes C2 to charge back up to +600 mV, and hence the time for which T2 is turned off, i.e. the pulse width. This is shown in figure 2d. Waveform C shows the negative base voltage applied to T2 for different

settings of P1, and waveform B shows how this affects the pulse width.

NOR-gate

The final main circuit element used in the multiplex encoder is a NOR-gate. This collects together the pulses from the different monostables and converts them into a pulse train. Figure 3a shows a two input NOR-gate together with its truth table. It can be seen from the truth table that if either input goes high then the output will go low. A multiple input NOR-gate can thus be used to collect pulses from the outputs of several monostables. If all inputs are normally low then if any input goes high a corresponding low-going pulse will appear at the NOR-gate output.

Figure 3b shows a multi-input NOR-gate using resistor-transistor logic (RTL) fabricated from discrete transistors. If all inputs are low then all transistors will be turned off and the output will be pulled high by the common collector resistor. However, if any input goes high the corresponding transistor will turn on and pull the output low.

Differentiator and integrator

Two other simple networks are extensively used in the multiplex encoder. These are the differentiating network shown in figure 4, and the integrating network shown in figure 5. The most useful property of the differentiating network is that of producing short pulses from step inputs. If a step input,

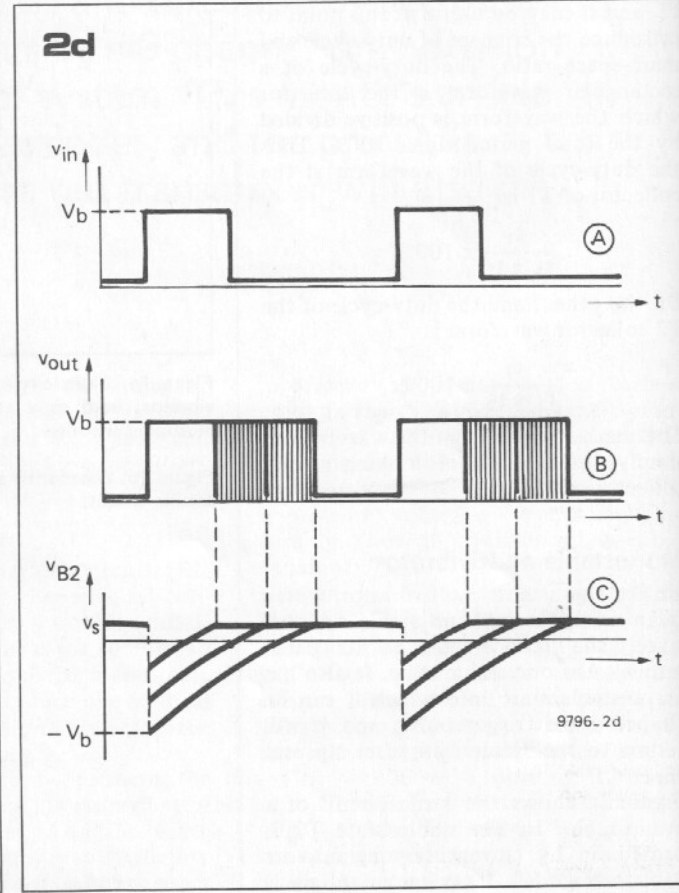
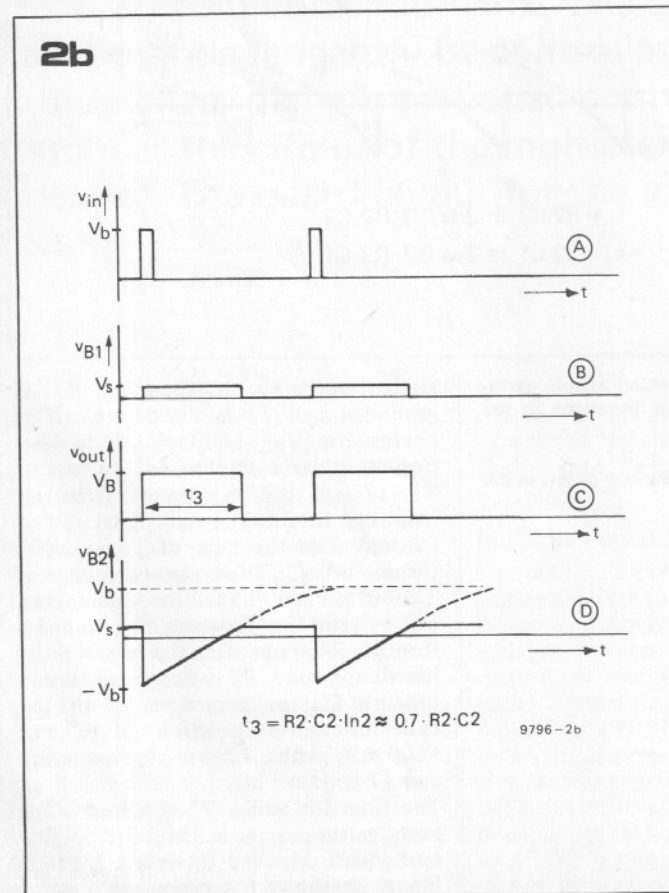
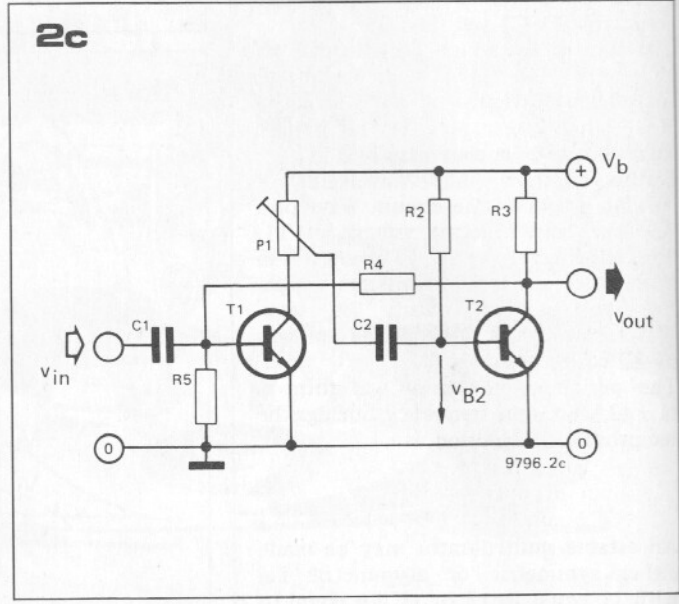
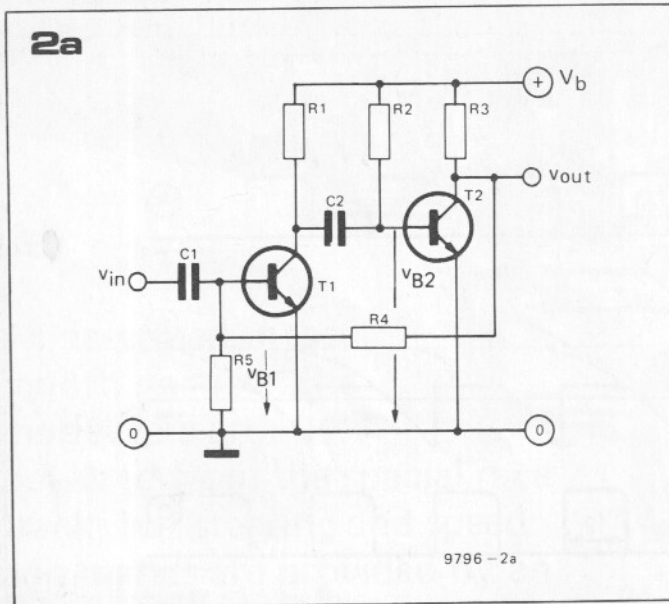

such as the leading edge of a square-wave, is fed to the network then the output voltage across R will initially be the same as the input voltage. However, as C charges the voltage across R will fall exponentially according to the equation

$$V_{out} = V_b \cdot e^{-\frac{t}{RC}}$$

When fed with complex AC signals the differentiator functions as a simple high-pass filter, attenuating the low frequency components of the signal. As might be expected, the integrating network functions in a more or less opposite manner. When fed with a step input the voltage across C is initially zero and rises slowly as C charges through R according to the equation

$$V_{out} = V_b (1 - e^{-\frac{t}{RC}})$$

The integrator is thus useful as a sort of delay network, and indeed is used as such in the astable and monostable multivibrators.

When fed with an AC signal the integrating network becomes a simple lowpass-filter.

Multiplex Encoder - block diagram

Having discussed the various elements that make up the multiplex encoder, the block diagram is given in figure 6a. The clock generator (an astable multivibrator) produces a 5 ms pulse every 25 ms, which triggers monostable MF1. This produces a pulse whose width can be varied by P1, and when it resets it

3a

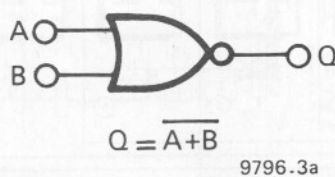

A	B	Q
0	0	1
0	1	0
1	0	0
1	1	0

9796.3a

3b

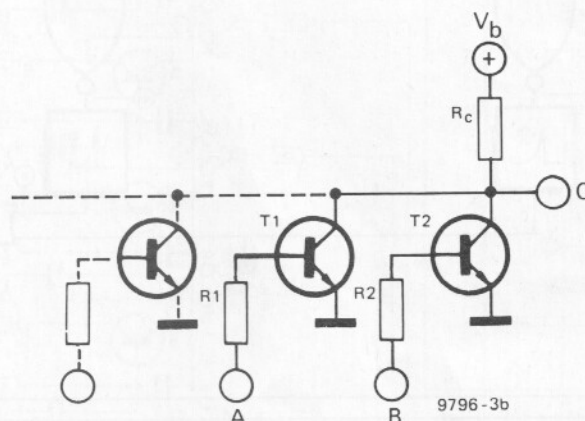

9796-3b

4

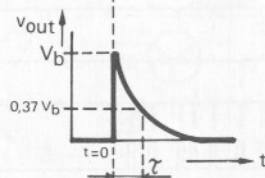
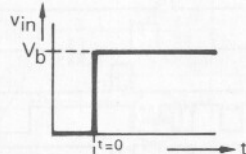
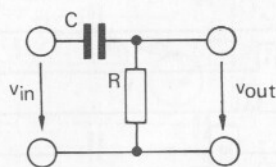

$$\tau = RC \quad 9796.4$$

Figure 2a. Basic circuit of a monostable multivibrator.

Figure 2b. Waveforms in the monostable circuit.

Figure 2c. P1 can be used to adjust the monostable pulse length.

Figure 2d. Showing how different positions of P1 vary the time for which T2 is cut off.

Figure 3a. Symbol and truth table of a two-input NOR-gate.

Figure 3b. A multi-input NOR-gate using resistor transistor logic.

Figure 4. A differentiating network, used to generate short pulses from step inputs.

Figure 5. An integrating network, used in the synchronising circuit of the decoder.

5

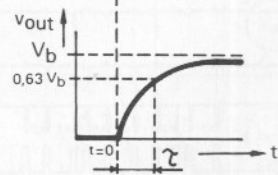
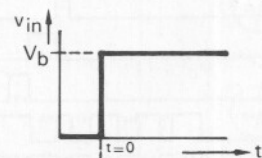
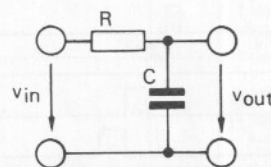

$$\tau = RC \quad 9796.5$$

6a

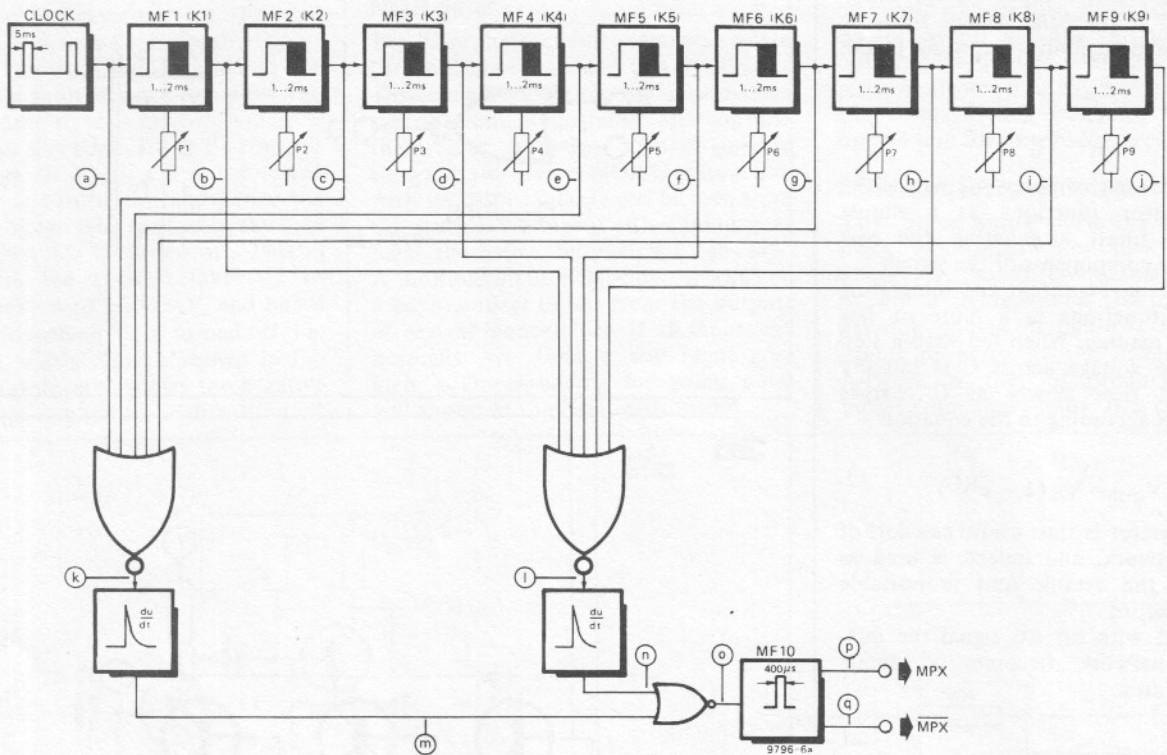

6b

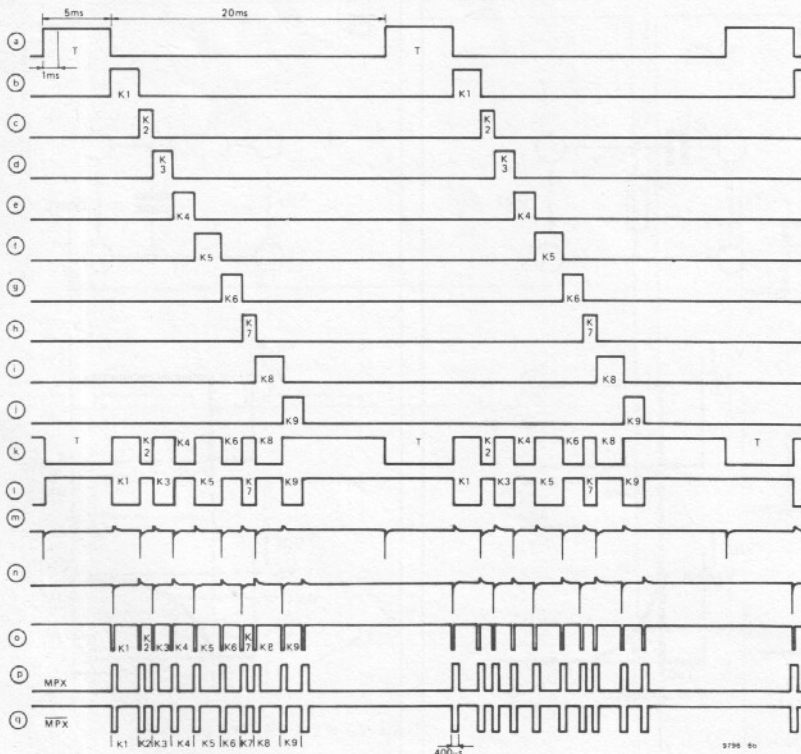

triggers MF2. When MF2 resets it triggers MF3 and so on up to MF9. Each clock pulse thus produces a train of nine servo control pulses. Each monostable is equipped with a control potentiometer to vary its pulse width and thus control its assigned servo.

Since each monostable pulse starts as the previous one finishes it is not possible to collect the monostable pulses directly and feed them to the transmitter. Because the pulses follow so closely the NOR-gate output would simply be a continuous low level, or at best a low level with extremely short positive spikes at the switchover point between one monostable and the next. Such a spiky waveform would require a very large transmitter bandwidth.

To overcome this difficulty the outputs of the clock and the even-numbered monostables are fed into one NOR-gate, while the odd numbered outputs are fed into a second NOR-gate. At this point it may be useful to refer to figure 6b. Waveform (a) is the clock output, and waveforms (b) to (j) are the monostable outputs. (k) and (l) are the outputs of the two NOR-gates and it can be seen that (l) is almost an inverted version of (k).

The next step is to differentiate the two NOR-gate outputs to produce a series of short spikes (m and n). Referring to figure 6b it can be seen that these spikes define the leading and trailing edges of the monostable pulses. Combining waveforms (m) and (n) in a third NOR-gate gives waveform (o), which is simply

Figure 6a. Block diagram of the multiplex encoder.

Figure 6b. Timing diagram for the multiplex encoder.

Figure 7. Complete circuit of the encoder. The transistors are not discrete devices, but IC transistor arrays.

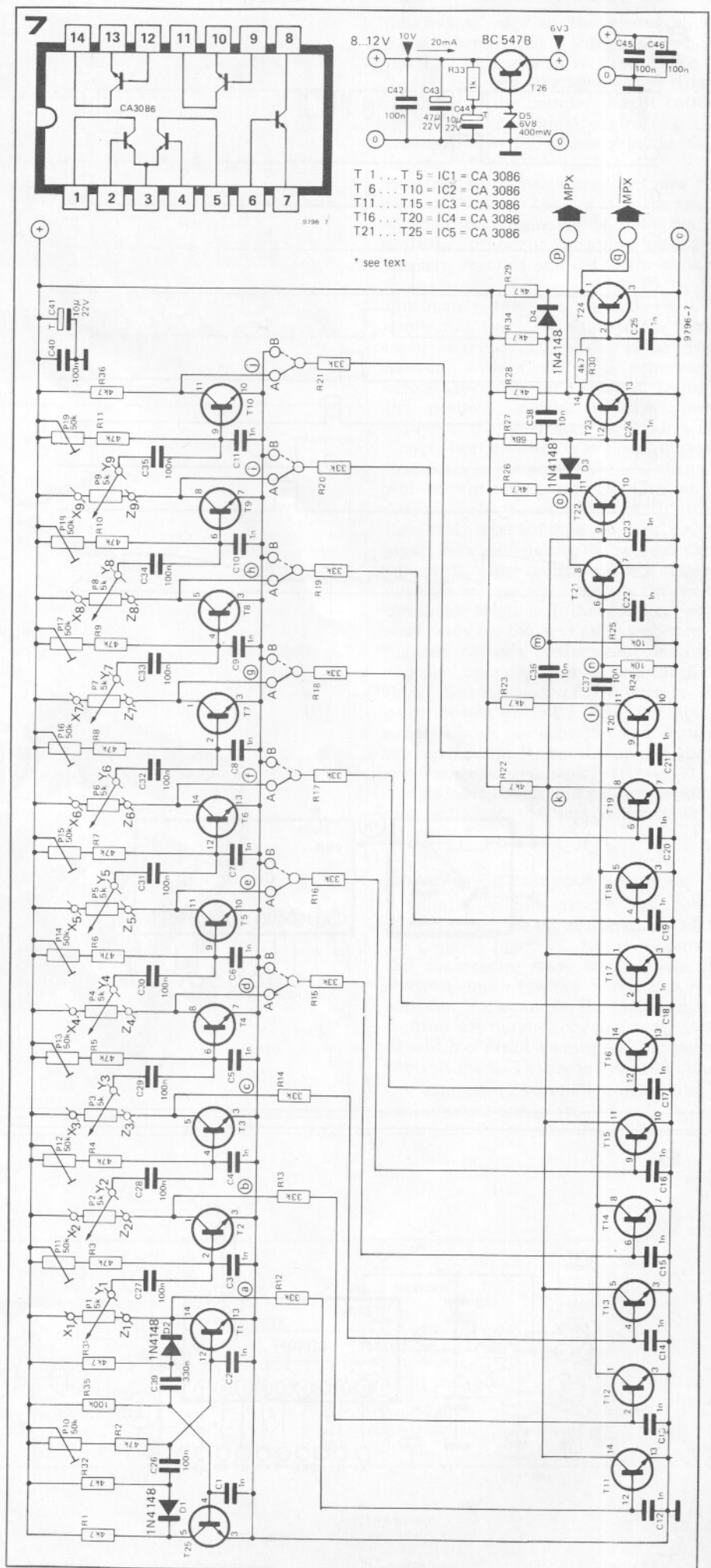

a train of pulses the same lengths as the original monostable pulses with short negative-going spikes between them. However, this waveform is still too 'spiky' for the transmitter, so the negative going pulses are used to trigger yet another monostable, which 'stretches' the spikes to a constant 400 μ s width. Both normal and inverted versions of the multiplexed signal are available at the output of MF10.

It will be noted that, since the maximum monostable pulse width is 2 ms the entire pulse train occupies a maximum of 18 ms which, since clock pulses occur every 25 ms, leaves a gap of at least 7 ms at the end of each pulse train, more if the monostables are set to a shorter pulse length. This gap is used to synchronise the receiver decoder with the encoded signal, so that each servo receives only the correct pulses.

Complete circuit

The complete circuit of the multiplex encoder is given in figure 7. The clock generator is constructed around T1 and T25, and the only difference between this and the basic astable circuit is the inclusion of diodes D1 and D2 and resistors R31 and R32, which help to speed up the leading edge of the rectangular waveform. The monostables are formed from transistors T2 to T10, and it will be noted that these are in fact only 'half monostable' circuits, in fact simply the pulse width determining portion of the circuit. Two of the NOR-

8

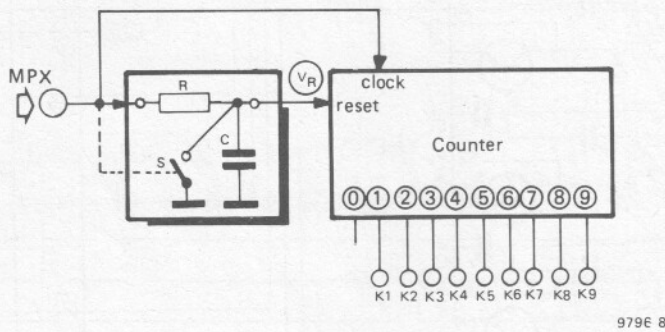
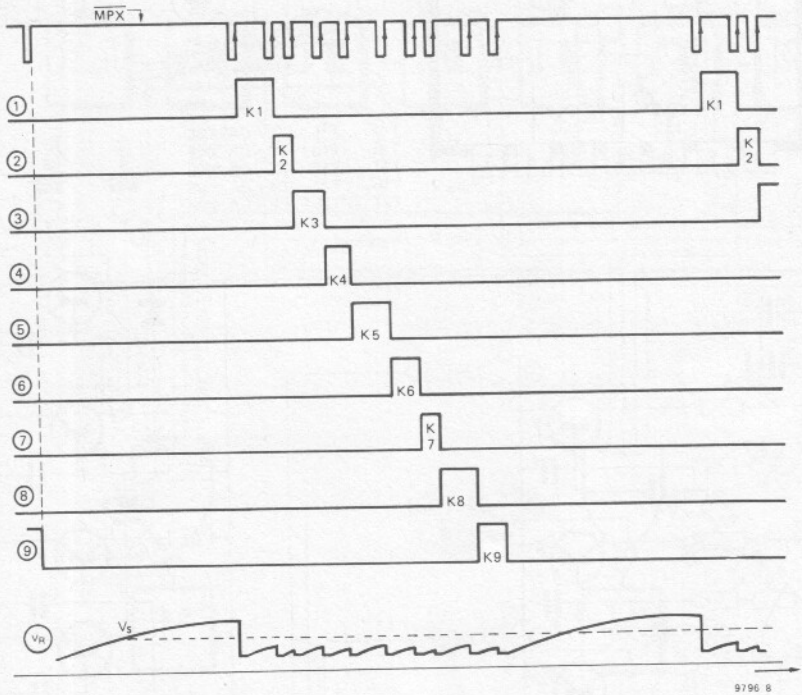

gates are made up from transistors T11 to T20, while the third NOR-gate comprises T21 and T22. The 400 μ s pulse-stretching monostable consists of T23 and T24, and the MPX and MPX signals are available at the collectors of T23 and T24 respectively. Capacitors C1 to C25 are included to reduce the susceptibility of the clock generator, monostables and NOR-gates to spurious pulses, which could upset the timing sequence. Note that these capacitors should be ceramic types. All other non-electrolytic types should be MKM polycarbonate or other good quality components, and resistors should have a tolerance of 5%.

The transistors used in the encoder are not discrete devices but are contained in five CA 3086 transistor arrays. Since the encoder is intended to be universal in application it has been made possible to use any or all of channels 4...9 for switched functions instead of proportional controls by including single pole change-over switches at points A and B. Also, the IC pinning is laid out so that if a maximum of only four channels is required for any application then T6 to T10 (IC2), T16 to T20 (IC4) and their associated components may be omitted. However, for the slotless car track all the components shown are required to control up to four cars, and resistors R15 to R21 should be soldered to position A on the p.c. board.

The encoder is provided with a simple stabilised supply to enable it to operate from an unregulated DC voltage from 8 V to 12 V.

Decoder principle

Referring now to figure 8, it is apparent that the decoder circuit should be capable of extracting from the multiplexed signal the original control waveforms K1 to K9 so that these can be fed to the appropriate servo channels 1 to 9. This can be accomplished by a simple decade counter having ten outputs. If the counter is initially at zero then on the leading edge of the first (K1) pulse in the multiplex signal the counter will clock and output 1 will go high until

9

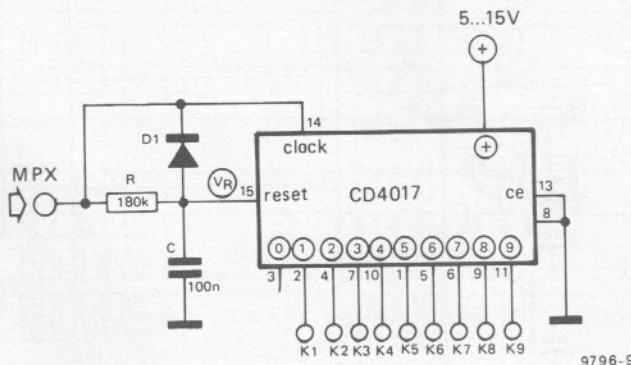
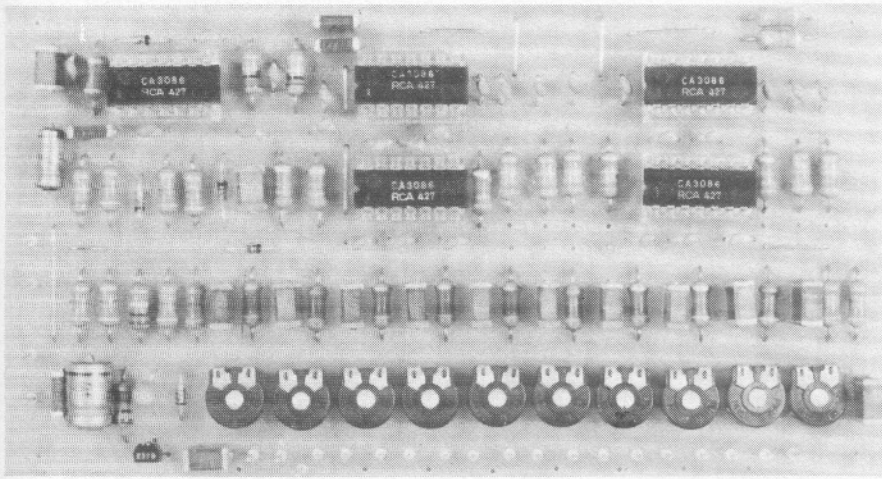

Figure 8. Showing the principle of the decoder.

Figure 9. Practical circuit of a decoder using a CMOS counter IC.

Figure 10. Showing how the joystick control potentiometers are connected to the multiplex encoder. One joystick control is required for each car — four in all.

Figure 11. Circuit of the infra-red transmitter, which was described last month.



the leading edge of the second (K2) pulse, when output 2 will go high until the third pulse and so on. From figure 8 it can be seen that the pulses thus obtained at the counter output correspond to the original control signals generated by the monostables in the encoder.

However, some means must be found of ensuring that the counter is in the reset state at the beginning of each pulse sequence, otherwise the pulses might be wrongly decoded and fed to the wrong servo channels.

Fortunately this is easily achieved by connecting the MPX signal to the reset input of the counter via an integrating network with a switch S connected across the integrator capacitor. During the positive periods of the pulse sequence the integrator capacitor will charge, but if switch S is closed during the spaces in the pulse waveform then C will be discharged and the integrator output voltage will not reach the threshold level of the counter reset input. However, during the space at the end of the pulse sequence C will charge until the voltage on it exceeds the reset threshold level, and the counter will reset ready for the next pulse sequence.

Figure 9 shows a practical circuit for a decoder operating on this principle. Here the function of the switch is performed by diode D1. While the input signal is high the capacitor can charge through resistor R, but if the input goes low C will discharge rapidly through D1. The decoder circuit will be discussed in more detail in the next article in this series.

Encoder - p.c. layout

A printed circuit pattern and component layout for the multiplex encoder are given in figure 12. Figure 10 shows the connections made to the joystick controls, one of which is required for each car. For example, the first joystick controls car number one and comprises P1 which controls steering and P2 which controls speed. The second joystick control comprises P3 and P4 which control car number 2 and so on.

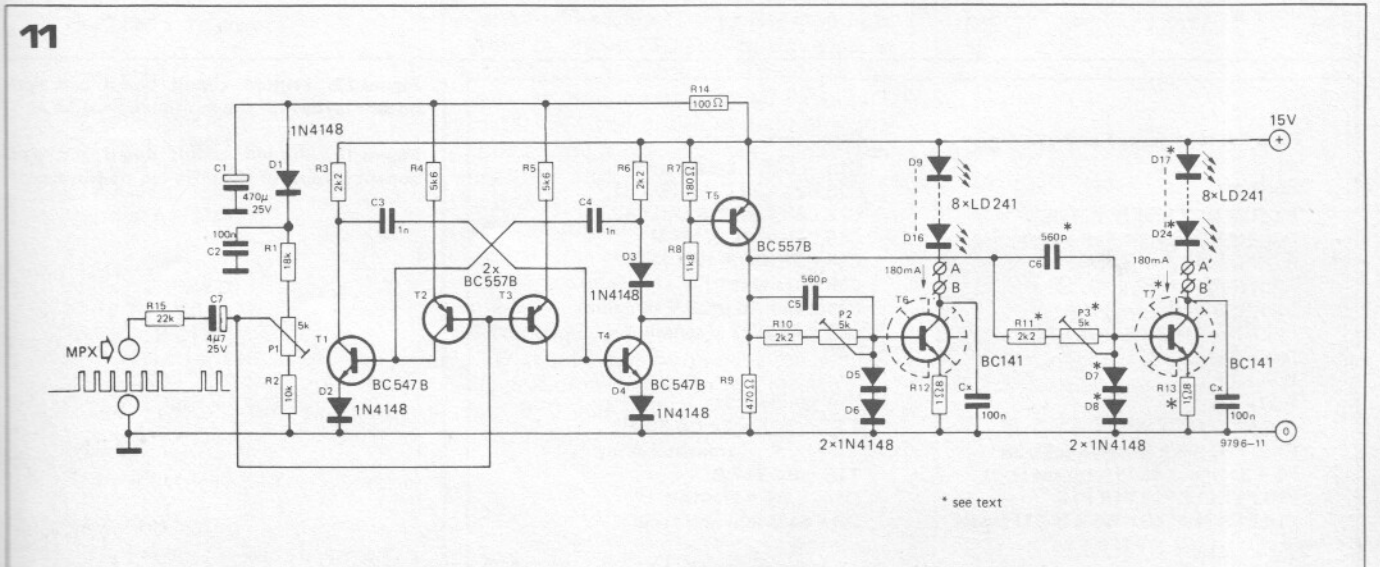
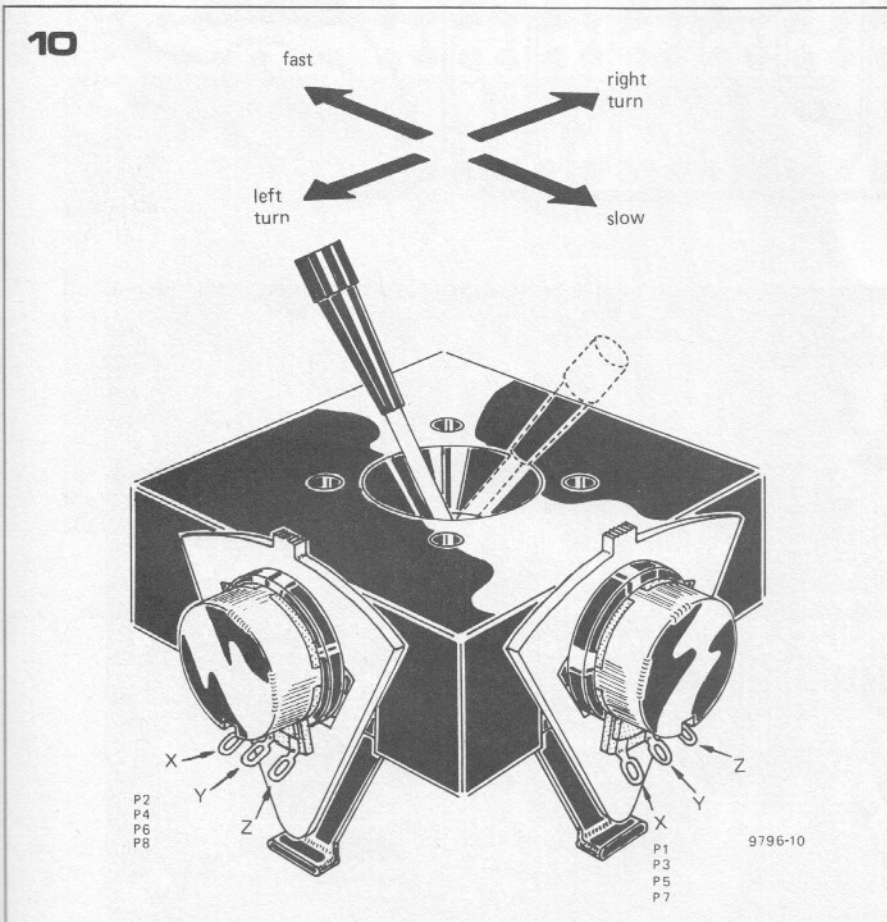

* see text

12

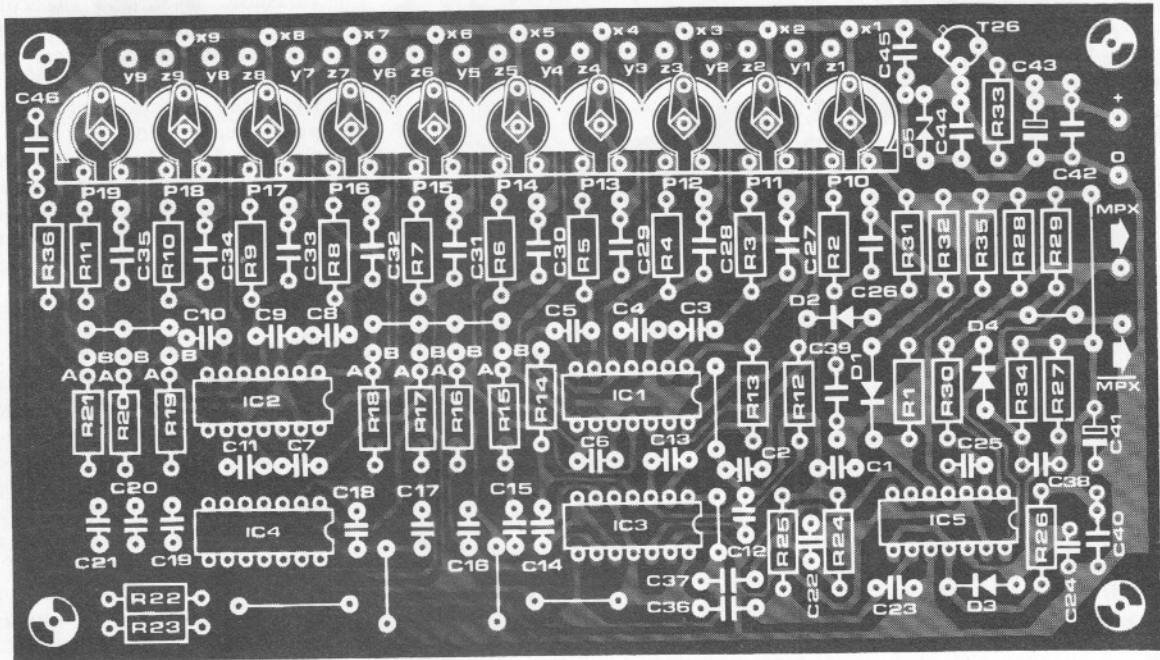
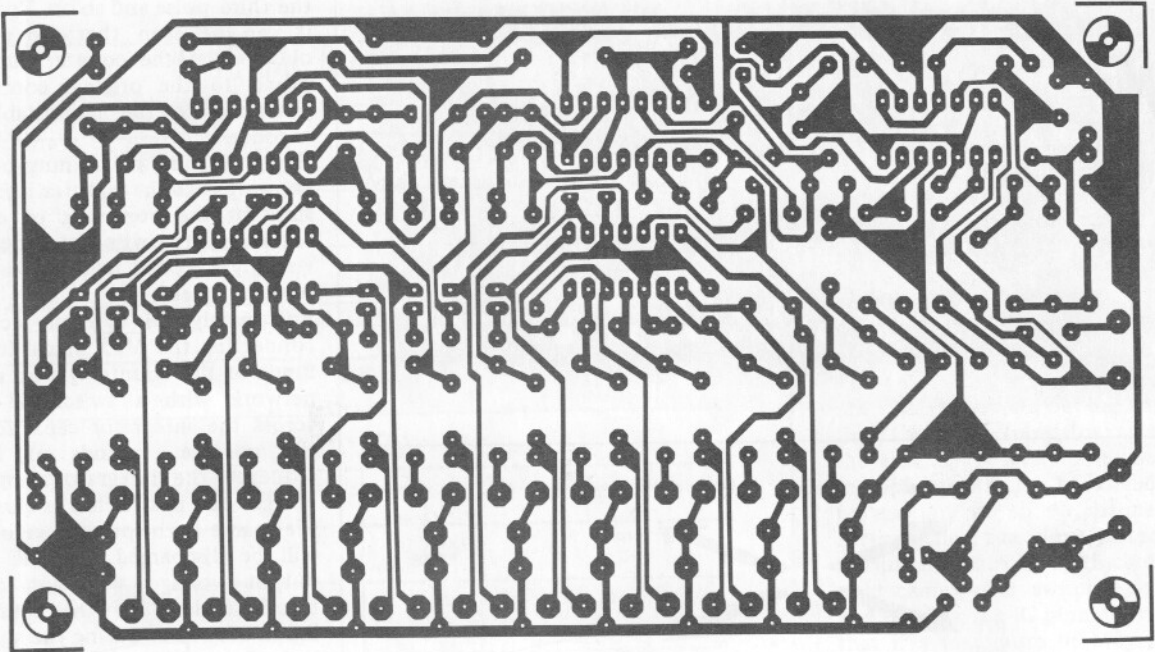

Parts list for figures 7 and 12.

Resistors:

R1, R22, R23, R26, R28, R29,
R30, R31, R32, R34, R36 = 4k7
R2, R3, R4, R5, R6, R7, R8,
R9, R10, R11 = 47 k
R24, R25 = 10 k
R12, R13, R14, R15, R16, R17,
R18, R19, R20, R21 = 33 k
R27 = 68 k
R33 = 1 k
R35 = 100 k
P1 ... P8 = 5 k joystick controls
P9 = 5 k lin or 4k7 fixed (see text)
P10, P11, P12, P13, P14, P15,
P16, P17, P18, P19 = 50 k (47 k) preset

Capacitors:

C1 ... C25 = 1 n ceramic
C26, C27, C28, C29, C30, C31,
C32, C33, C34, C35, C40, C42,
C45, C46 = 100 n MKM
C36, C37, C38 = 10 n MKM
C39 = see text
C41, C44 = 10 μ /22 V tantalum
C43 = 47 μ /22 V tantalum

Semiconductors:

T1 ... T25 = 5x CA 3086
transistor-array
T26 = BC 547 B
D1 ... D4 = 1N4148
D5 = 6V8/400 mW zener

Figure 12. Printed circuit board and component layout for the multiplex encoder.

Figure 13. Printed circuit board and component layout for the infra-red transmitter.

13

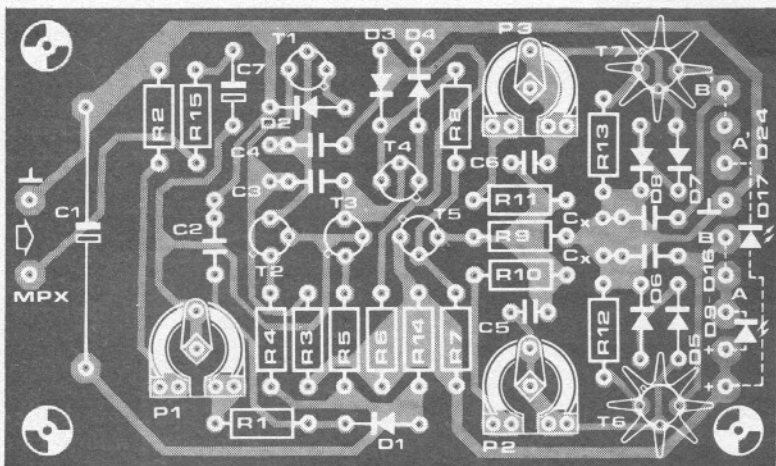
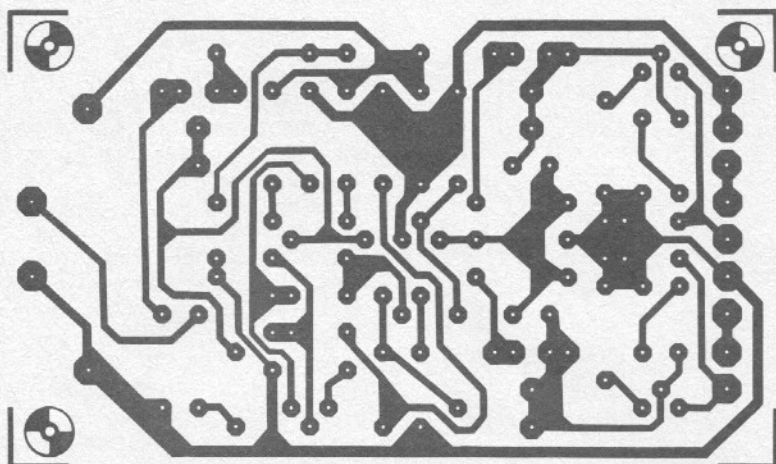

Parts list for figures 11 and 13.

Resistors:

R1 = 18 k
 R2 = 10 k
 R3, R6, R10, R11* = 2k2
 R4, R5 = 5k6
 R7 = 180 Ω
 R8 = 1k8
 R9 = 470 Ω
 R12, R13* = 1.028
 R14 = 100 Ω
 R15 = 22 k
 P1, P2, P3* = 5 k preset

Capacitors:

C1 = 470 μ /25 V
 C2 = 100 n MKM
 C3, C4 = 1 n MKM
 C5, C6* = 560 p ceramic
 C7 = 4 μ 7/25 V
 C_x = 100 n MKM (2x)

Semiconductors:

T1, T4 = BC 547 B
 T2, T3, T5 = BC 557 B
 T6, T7* = BC 141
 D1 ... D8 = 1N4148
 D9 ... D16 = LD 241
 D17* ... D24* = LD 241

Miscellaneous:

2 x heatsinks TO 5 type

NB. * = see text

If the unit is used to control four cars in this way, P9 will be redundant. If this channel is not used at all, P9 can be replaced by a fixed resistor between points X9 and Z9.

Testing and fine adjustment of the multiplex encoder will be given in a later article.

Infra-red transmitter

Finally, the p.c. board and component layout for the infra-red transmitter, the circuit of which was given last month, is given in figure 13. The circuit itself is reproduced in figure 11. To adjust the infra-red transmitter, first set P2 and P3 to their central positions and allow the circuit to warm up for about ten minutes. Insert an ammeter between points A and B and adjust P2 to give a T6 collector current of about 180 mA. Repeat this procedure with P3 for T7 (meter connected between points A' and B').

With some specimens of the LD 241 LED it may not be possible to reduce the collector current to 180 mA. In this case R10 and R11 should be increased to 3k3.

(To be continued.)

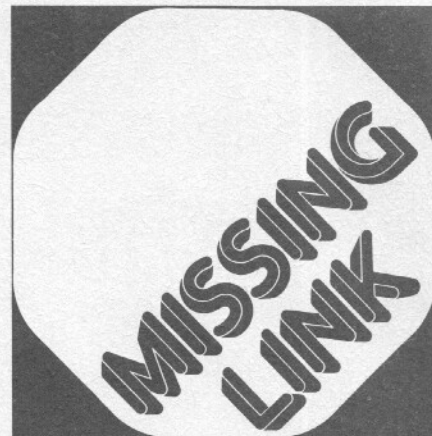

Modifications to
 Additions to
 Improvements on
 Corrections in
 Circuits published in Elektor

LED VU/PPM

April 1977, E24, p. 4-32. It was perhaps not made sufficiently clear that the display itself (figure 5) works off an asymmetrical power supply (+15 V). No negative (-15 V) supply is required: points '0' and '-' on the display board (figure 7) are both connected to supply common. The rectifier section (figures 2 and 6) does require a symmetrical (+/- 15 V) supply, of course.

Speech shifter

July/August 1976, E15/16, p. 742. In some cases the TBA 120 has been found to be so asymmetric that the oscillator signal is audible at the output. The solution in this case is to add a 22 k or 25 k preset potentiometer between pins 7 and 9 of the IC; the slider is connected to supply common through a 10 k resistor.

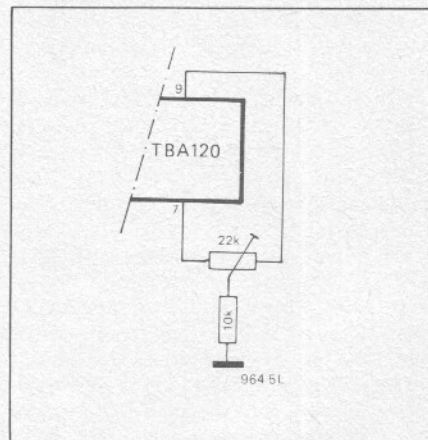

coming
 soon

- Precision timebase
- Microprocessors
- 'Wireless' intercom
- Elektor SUMMER CIRCUITS issue

op-amp frequency compensation... the why and the how

When an operational amplifier is used in a negative feedback circuit its frequency response requires 'compensation', a high-frequency rolloff that may be 'internal' or 'external'. With inadequate compensation the circuit will usually misbehave or even oscillate. This article will explain the reasons for frequency compensation, describe the usual 'simple' approach and then show how an 'external' type can be fitted with an improved compensation-arrangement. The latter approach results in a circuit that responds far better to large and fast excursions of the input signal.

Why does an operational amplifier need compensation? The story starts with the observation that parasitic capacitances in the IC itself cause the 'open-loop' (i.e. without-feedback) response of the device to roll off more or less sharply above a certain high frequency. This is illustrated by the drawn line in figure 1 — the 'uncompensated' response. The actual curve is bounded by asymptotes, 6 dB/octave (20 dB/decade) above f_1 , 12 dB/octave above the second turnover point f_2 and even 18 dB/octave above f_3 in cases where there is a third turnover. The open-loop gain is constant from DC to f_1 (the real curve 3 dB 'down' at f_1), equal to the value A_{OL} . Figure 1 also shows the desired gain-with-feedback-operating, A_{CL} (in decibels). If the slope of the open-loop response at the intersection with the horizontal through A_{CL} exceeds 12 dB/octave, the actual feedback will start to become positive, as the total phase-shift will have exceeded 180° . With the values assumed in the figure the op-amp would certainly be in business for itself! The only way to 'dump' enough open loop gain before the phase-shift in the IC exceeds 180° is to provide HF rolloff, starting early enough — so that the intersection between the open-loop and closed-loop response curves occurs

at 6 dB/octave. A step-network that 'flattens' again at f_1 (drawn curve in figure 2) is the standard trick. It will result in the dashed curve of figure 1.

The situation is in fact that the 'loop gain' falls below the amount that would enable oscillation, if the feedback were to become positive, at a point where there is still 90° phase-margin.

Note that many integrated op-amps have their frequency compensation built-in. An internal capacitor then displaces one of the 'stray' rolloffs so far downward in frequency that it dominates in the response, automatically providing the figure 1 dashed curve. Perhaps the best known example of this is the '741'.

Those op-amps that are intended for use with external compensation are supplied with data on how this should be done, given the required values of closed-loop gain, phase-margin etc. For most applications the instructions err on the 'safe' side.

That concludes the review of the basics of frequency-compensation. It is now time to take a closer look — preferably inside the IC! It will be convenient to assume the usual op-amp circuit of differential input stage, second stage with gain and some form of wideband unity-gain output stage (usually with

local feedback and biased in class B). The rolloff time-constant is normally inserted between the first and second stages or as a 'Miller' integration network in the second stage itself.

It is not difficult to see that an op-amp with the figure 1 dashed response, obtained by a 'slow' second stage, will have its input stage driven progressively harder above f_1 , due to the failing feedback (6 dB/octave above f_1 , 12 dB/octave above f_2).

There is a distinct danger that rapidly-changing high-amplitude signals will cause the input stage to momentarily saturate, at the steepest part of the waveform — usually the zero-crossing. This results in bursts of gross distortion — in audio amplifiers — known as Transient Intermodulation or TIM (see Equin part 1, Elektor 12, April 1976, p. 448).

The solution to this problem is to insert the compensation network at the amplifier input. Figure 3a shows how this is done for a non-inverting amplifier and figure 3b gives the inverting circuit. The figure also gives rules for determining the resistor and capacitor values required. Some op-amps will misbehave with nothing connected to their 'compensation' pins; it is not always immediately apparent why — so that no general rule can be given. A trick that usually works is to insert a series RC-pair that reduces the open-loop gain by 6 dB or so, in a step, at some frequency above the highest input but well below f_1 , at the usual compensation position.

The insertion of the compensation ahead of the input stage removes the cause of slew-rate limiting and TIM; the drive level of the input stage proper no longer rises with frequency during the sloping part of the open-loop response.

There is however a price to be paid, quite apart from the extra mess around the input pins. Noise from the input stage is no longer attenuated by the compensation network — it receives the full open-loop gain up to f_1 . The kind of circuit in which TIM is a problem (high level) is however not usually so critical in respect of noise. Furthermore, the low source impedance at higher frequencies 'seen' by the input stage will tend to reduce its noise level anyway. ■

Figure 1. The drawn line shows the op-amp's frequency response without 'compensation'. The dashed line shows the compensated or rolled-off response. At its point of intersection with the horizontal dotted line through A_{CL} (the so-called 'closed-loop gain', i.e. the amplification obtained with feedback operating), this response curve slopes at 6 dB/octave (20 dB/decade) — and the system is unconditionally stable.

Figure 2. A so-called 'step-network' compensation will cause the drawn line in figure 1 to follow the 'compensated' response curve shown dashed in figure 1.

Figure 3. Basic circuit and 'design rules' for improved compensation of a non-inverting (a) and an inverting amplifier (b).

morse call sign generator

A.J.B.M. Peters

Readers may remember that a design for an automatic callsign generator was featured in Elektor a little over a year ago (Elektor 11, February 1976). This new design offers the same facilities with considerably simpler circuitry, though at the expense of a slightly more complicated programming procedure.

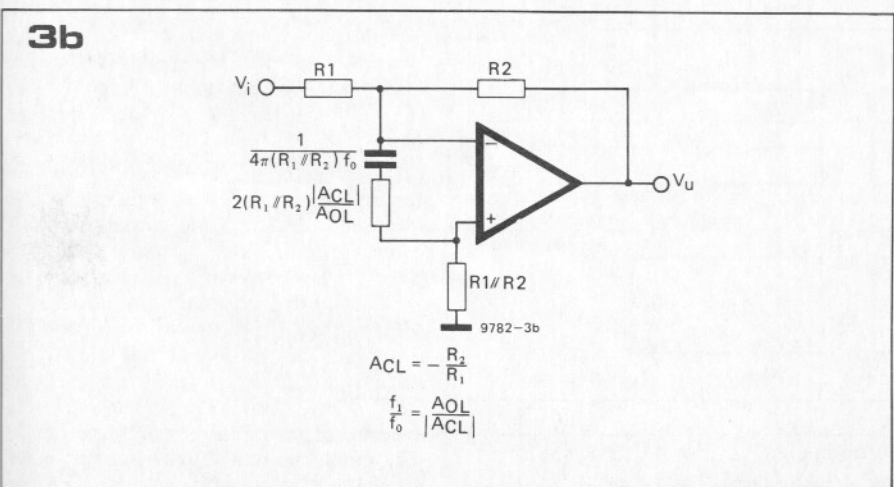
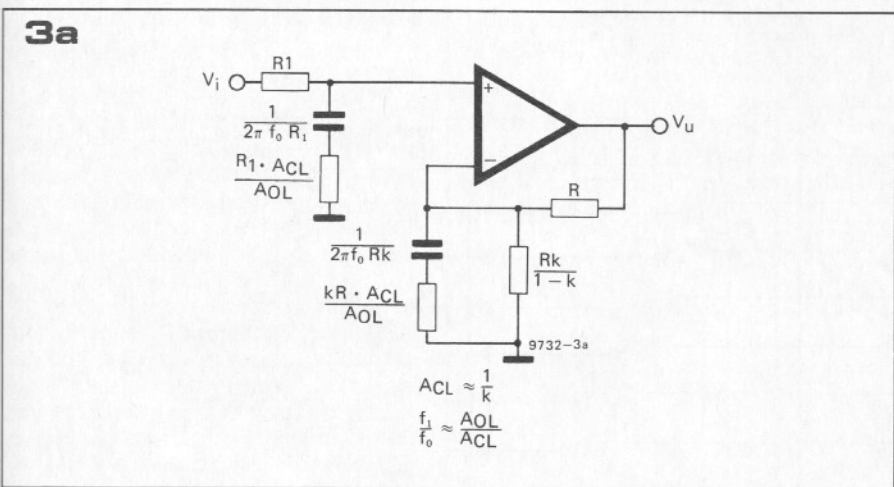
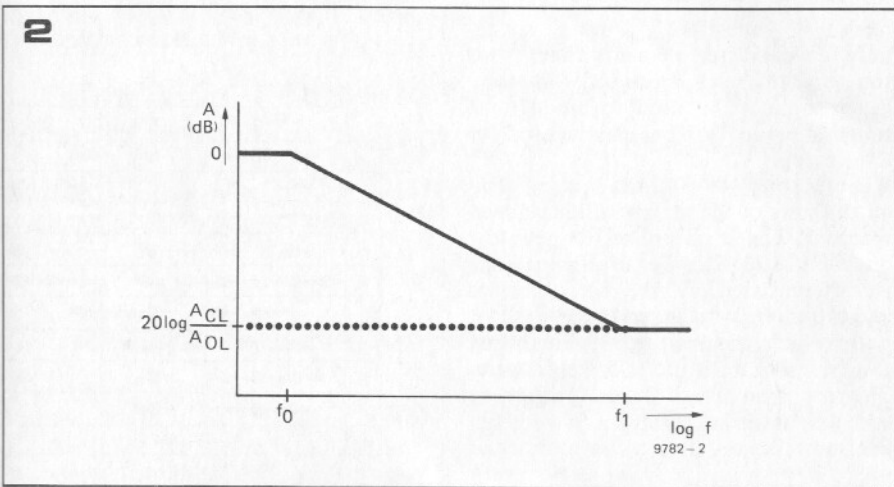
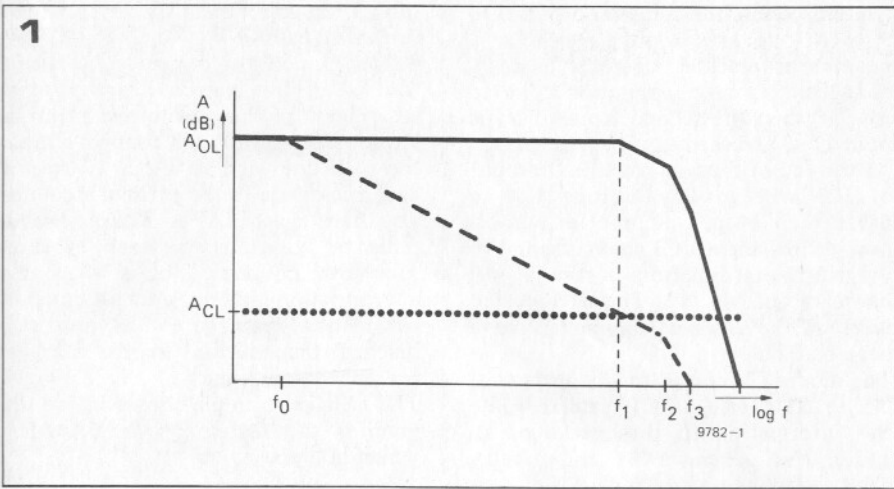

It may be remembered that the previous design for a callsign generator used CMOS shift registers whose outputs were connected via diodes to two programming lines. This made for very simple programming but made the circuit fairly complicated. The programming of the new design is accomplished by storing the callsign in a 100 bit read only memory consisting of a diode matrix. A dot is stored in the matrix by inserting one diode in the required position. A dash, which has a duration equal to three dots, requires three diodes. A space within a character is of one dot duration and occupies one blank space (no diode) in the matrix. A space between letters is the same duration as a dash and thus occupies

three blank spaces in the matrix. To generate the callsign the contents of the matrix are read out row by row. 100 bits may seem excessive, but it is possible for a single figure (digit 0) to occupy 19 spaces in the matrix. This, combined with long European call signs, soon uses up the spaces in the memory. British callsigns of 4 or 5 characters will, of course, not use as much of the memory capacity.

The complete circuit of the callsign generator is given in figure 1. The diode matrix is in the top left corner of the diagram. Readout is accomplished by addressing the rows and columns of the matrix using two 7490 decade counters and 7442 decoders.

The rate at which the callsign is repeated is determined by IC5, a 555 timer connected as a monostable multivibrator. Assume that initially the monostable is in the triggered condition. The output, pin 3, is high, so both the counters IC3 and IC4 are held in the reset condition. Output 0 of IC1 (column 0) and output 0 of IC2 (row a) are thus both low and all other outputs are high. One input of NOR gate N1 is low and the other is high, since no diode is connected in position 'a0' in the matrix as this is the rest position. The output of N1 is thus low. When the monostable (IC5) resets, the reset inputs of IC3 and IC4 go low and IC3 begins to count pulses from the clock generator built around S2. As the

counter counts the column outputs 0 to 9 of IC1 go low in turn. Whenever a position is reached where a diode is connected from a column output to row 'a' then the second input of N1 is pulled low and the output goes high. At the end of the first row the D output of IC3 will go low, causing IC4 to advance one step. One input of N2 will now be low and as IC3 counts from 0 to 9 again the information on row 'b' will be read out via N2. This is repeated until all the rows of the matrix have been read out.

The diodes connected to the outputs of N1 to N10 form an OR gate to route the information to the inputs of an audio tone generator S1 and a relay driver T1. When a dot or dash is present the tone generator is activated and the relay is energised. During spaces between character elements there is no tone and the relay drops out. The tone generator may be used to modulate a transmitter or the relay may be used for CW keying.

When a count of 100 has been reached all the rows of the matrix will have been read out. The D output of IC4 goes low on count 100. This negative-going edge is differentiated by the 1 nF capacitor and 10 k resistor to produce a short pulse which triggers the 555, inhibiting the counters until the 555 resets again. The repetition rate of the callsign can be varied by means of P1.

Programming requires a fair number of

diodes, the exact quantity depending on the actual callsign.

To programme the generator, start with row 'a' of the matrix. Leave position 'a0' blank as this is the rest position. Work along row 'a' and connect a diode for each dot with its anode to row 'a' and its cathode to the particular column you have reached. For a dash a diode must be connected to each of three successive columns. For a space the appropriate number of columns must be left blank. When the end of row 'a' is reached then return to the start of row 'b' and continue.

The callsign example shown in the diagram is the author's, DE PA0ARR, which in morse is

... ..

This is laid out in the matrix as follows:

	column									
row	0	1	2	3	4	5	6	7	8	9
a		•	•	•		•		•		
b		•						•		•
c	•	•		•	•	•		•		
d		•		•	•	•				•
e	•	•		•	•	•		•	•	•
f		•	•	•		•	•	•		
g		•		•	•	•				•
h		•	•	•		•				•
i		•	•	•		•				
j										

Figure 1. Complete circuit of the callsign generator. The desired callsign is stored in the diode matrix in the top left-hand corner.

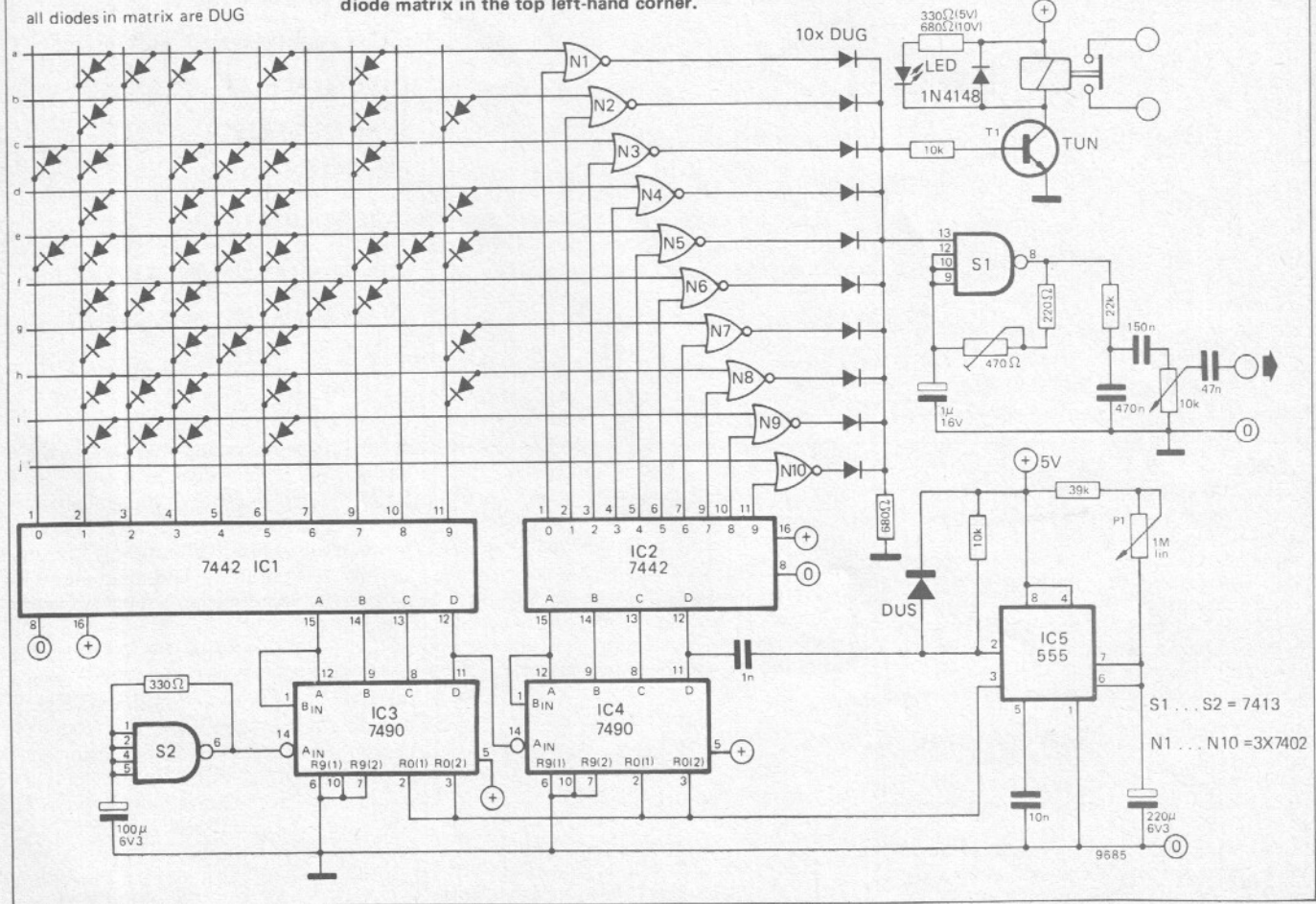

music cleaner

In response to popular demand, here, at last is a treble and rumble filter that can be used in virtually any hi-fi system to get rid of the snaps, crackles, pops and (g)rumbles without getting rid of half the music.

There has been much speculation about who first coined the phrase 'The wider you open the window, the more the muck blows in'. However, there is no disputing its truth with respect to audio systems. The bandwidths of pickup cartridges, amplifiers and loudspeakers are now so great that the imperfections of records and turntables are often glaringly exposed, even by a relatively inexpensive cartridge, amplifier and loudspeakers.

Quite apart from the argument as to whether these phenomenal bandwidths actually serve any useful purpose apart from churning up one's innards at the bass end and annoying the neighbour's dog at the treble end, there is obviously a need to 'chop off' the top and bottom end of the audio spectrum under certain circumstances. Turntables, for example, are not always as rumble-free as one might wish, and being mechanical devices tend to get worse with age. Records, too are rarely perfect, suffering often from rumble and even more frequently from surface noise, which latter tends to become worse with wear. Then, of course, one must consider the enthusiast who possesses treasured collections of older records or non-noise-processed tapes.

Design requirements

Unfortunately, few amplifiers, except the most expensive ones, possess effective treble and bass filters, simply because the requirements for such filters are rarely properly formulated. Firstly, the turnover (-3 dB) points of the filters should be chosen carefully. Many treble filters cut off at much too low a frequency, leading to loss of part of the wanted signal. Similarly, rumble filters often cut off at too high a frequency.

The treble filter in the present design has a choice of two cutoff points. A cutoff point of 25 kHz is chosen to prevent ultrasonic signals from reaching the power amplifier, as these can lead to the (now) well-known transient intermodulation distortion (TIM). For elimination of record and tape noise a cutoff frequency of 10 kHz was chosen. The circuit can easily be adapted to give many other different cutoff frequencies according to personal taste, calculation of the required component values being a relatively simple matter.

For the rumble filters a cutoff fre-

quency of 25 Hz was chosen, but again this can easily be altered if so desired.

The ultimate slope of the filter is also important. Some filters have a slope of as little as 6 dB/octave. This means that, to be effective in suppressing rumble or noise the turnover point of the filter must be within the frequency range of the wanted signal leading to partial loss of the signal or, to use another metaphor, 'throwing the baby out with the bathwater'.

Choice of Response

To avoid this both the filters used in the present design have an ultimate slope of 18 dB/octave. There still remains, however, the choice of filter design. The magnitude/frequency response of the so-called Butterworth type of filter is maximally flat in the passband. The Chebishev filter attains a sharper cutoff at the turnover point than does the Butterworth, but at the expense of a magnitude frequency response that is not flat in the passband. However, neither of these types are concerned with phase distortion of the signal, which is important when dealing with complex waveforms such as music. To minimise phase distortion the phase

Figure 1. Theoretical circuit of the third order lowpass Bessel filter used for the treble filter.

Figure 2. Theoretical circuit of the third order highpass Bessel filter used for the rumble filter.

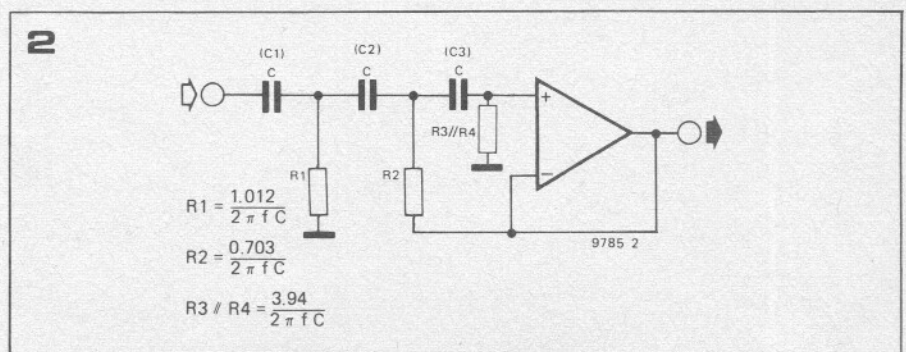
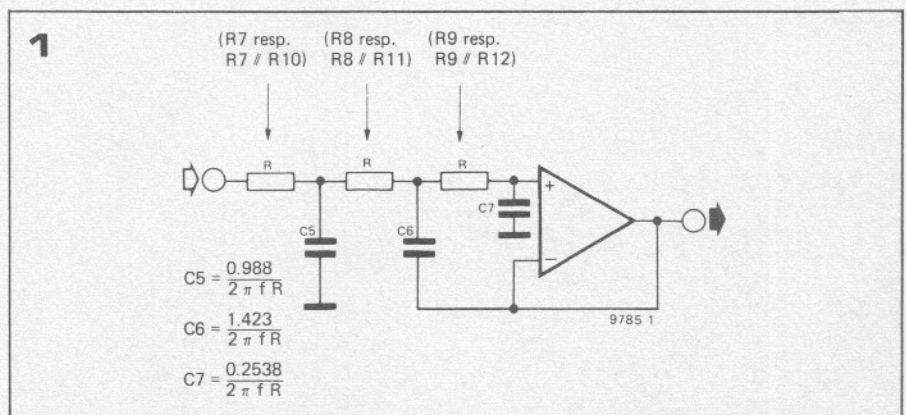

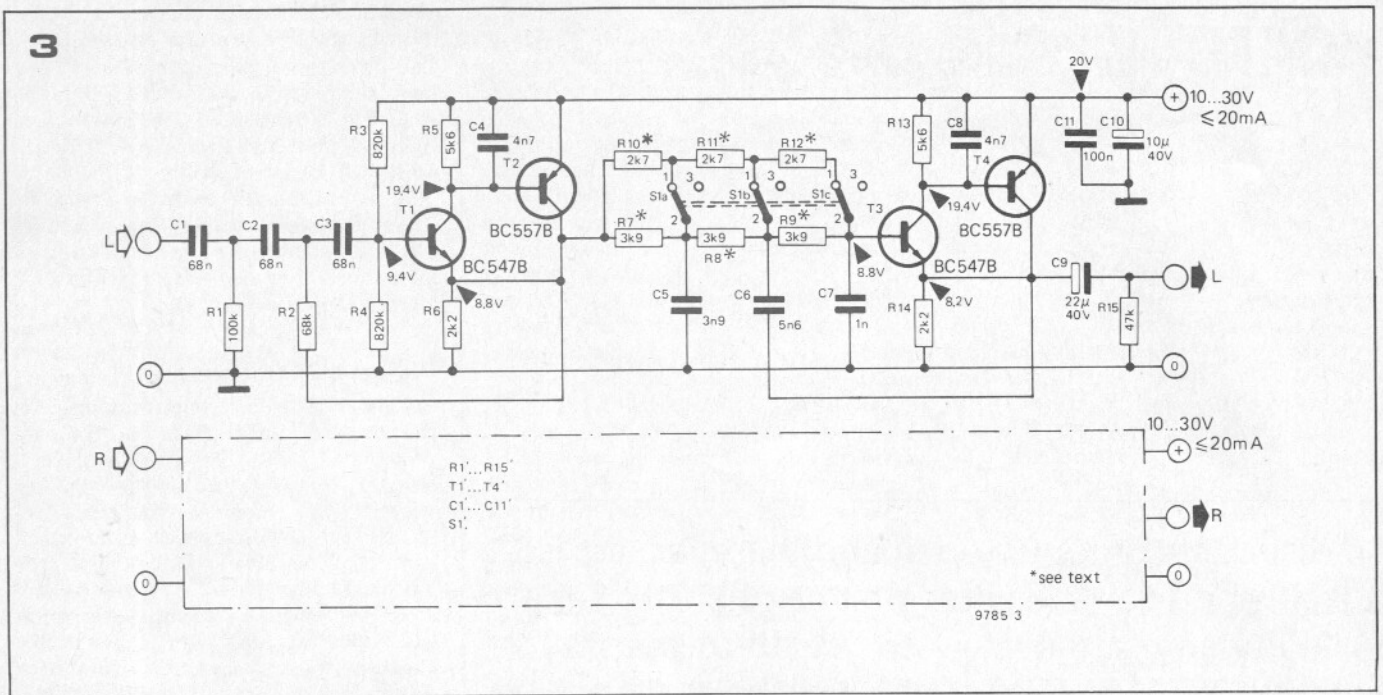

shift ϕ , produced by a filter should vary linearly with frequency. This condition is fulfilled by a filter having a Bessel type of response. This produces minimum phase distortion, though the cutoff at the turnover point is not as sharp as either the Butterworth or Chebishev filters. Three-pole Bessel filters were thus chosen for this design.

Having decided on the best type of filter response one is then faced with the problem of practical realisation. There are various realisations, some of which require infinite open-loop gain from the active part of the circuit. While these requirements can be approximated using IC operational amplifiers, such ICs are not ideal from the point of view of distortion and noise.

The configuration finally chosen was that using a voltage follower. This is easy to realise with low-noise audio transistors, and the overall gain of the filter within the passband is unity, which means that it can be inserted in any amplification chain without affecting the gain.

Figure 1 shows the theoretical circuit of the lowpass (treble) filter, while figure 2 shows the theoretical circuit of the highpass (rumble) filter. The three resistors in the lowpass filter are identical, and the values of the three capacitors required for a given turnover frequency can be calculated from the three equations given. Once the capacitor values for a given frequency have been found then the turnover frequency

may be altered simply by changing the values of the three resistors. e.g. if the resistors are halved the turnover frequency is doubled, if they are doubled the frequency is halved.

For the highpass filter the three capacitor values are equal and the resistor values are calculated from the equations given. In this case halving the capacitor value will double the turnover frequency, and doubling them will halve it. The equations for obtaining the filter parameters are reproduced from 'Electronics' August 18th 1969.

Practical Circuit

To obtain a treble and rumble filter in the same unit the two circuits of figures 1 and 2 are simply cascaded. The complete practical circuit of one channel of the filter is given in figure 3. Here the theoretical voltage followers have been replaced by transistors connected in a 'super emitter-follower' configuration. The rumble filter is built around T1 and T2. R3 and R4 perform a dual function, forming part of the rumble filter but also providing the base bias for T1. The effective value of these resistors as far as the filter is concerned is R3 paralleled with R4 or $\frac{R_3 \times R_4}{R_3 + R_4}$.

The treble filter is built around T3 and T4. Selection of the turnover point is carried out by a three way switch. With the switch open only R7, R8 and R9 are in circuit, and the turnover point is about 10 kHz. With the switch closed these resistors are connected in parallel with R10, R11 and R12 respectively, and the turnover point goes up to about 25 kHz. Capacitors C4 and C8 are included to guard against the possibility of r.f. instability.

The circuit has a high input impedance and low output impedance, so that it may be connected virtually anywhere in an audio system. For use with an existing amplifier the unit may be connected to the tape socket if this is

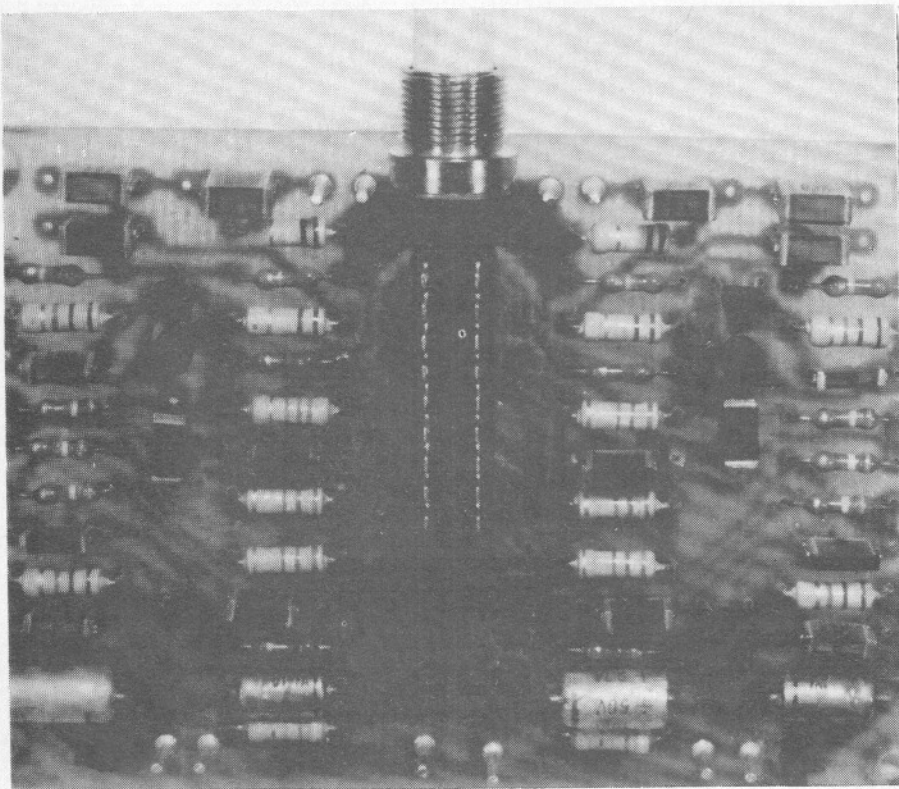

Parts list to figures 3 and 4

As the p.c. layout is for a stereo system all components except S1 are duplicated.

Resistors:

R1 = 100 k
 R2 = 68 k
 R3, R4 = 820 k
 R5, R13 = 5k6
 R6, R14 = 2k2
 R7, R8, R9 = 3k9 (see text)
 R10, R11, R12 = 2k7 (see text)
 R15 = 47 k

Capacitors:

C1, C2, C3 = 68 n
 C4, C8 = 4n7
 C5 = 3n9
 C6 = 5n6
 C7 = 1 n
 C9 = 22 μ /35 ... 40 V
 C10 = 10 μ /35 ... 40 V
 C11 = 100 n

Semiconductors:

T1, T3 = BC547B, BC107B or equivalent.
 T2, T4 = BC557B, BC157B or equivalent.

Miscellaneous:

S1 = six pole on/off with normally closed contacts.

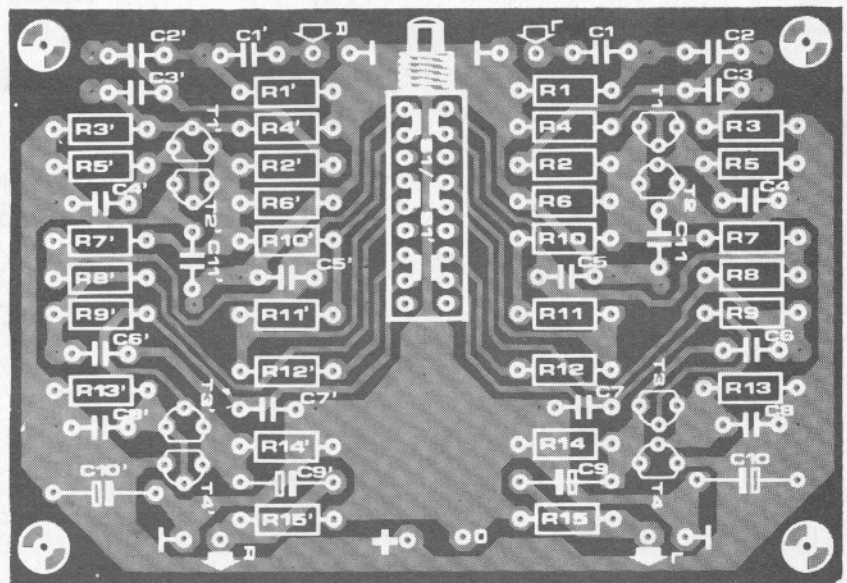
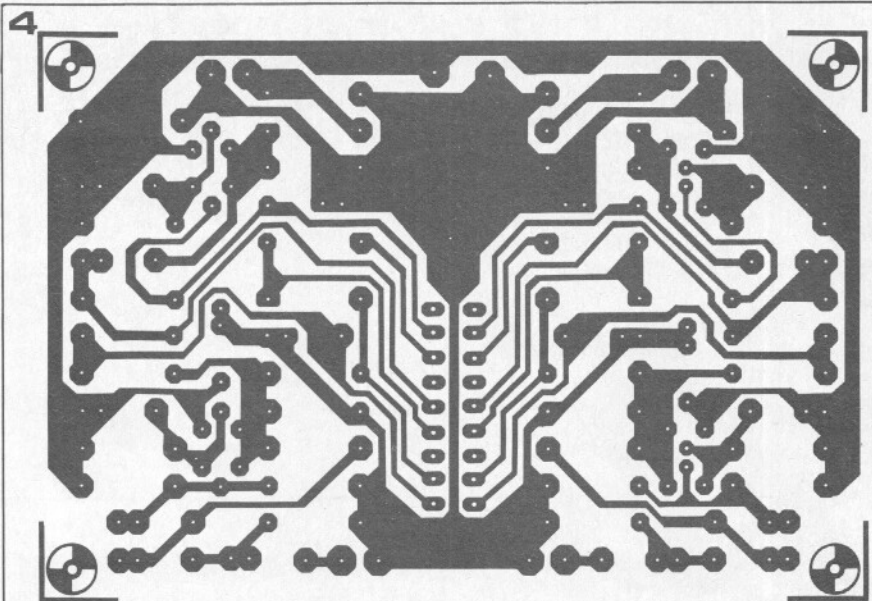
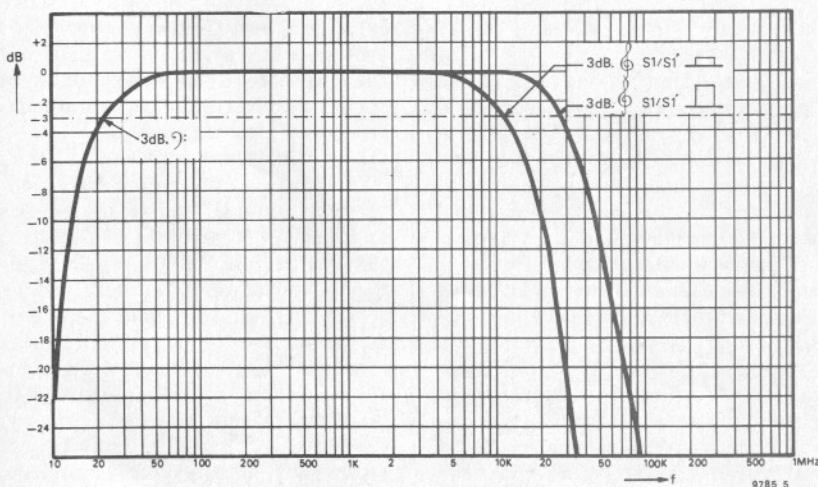

Figure 3. Complete circuit of the rumble and treble filter.

Figure 4. Printed circuit board and component layout for the filter unit.

Figure 5. Gain/frequency response curve of the filter unit.

5



not already in use. The input to the filter is taken from the 'tape' output of the amplifier and the output from the filter is fed back to the 'tape' input. Depressing the 'Tape Monitor' button will then bring the filter into circuit. Distortion introduced by the filter is extremely low so that it may be used with the highest quality systems.

Printed Circuit Board

A printed circuit board and component layout for the stereo filter are given in figure 4. Provision is made on the p.c. board for mounting a pushbutton switch for S1. Alternatively S1 may be mounted remote from the board provided the leads are not more than a few centimetres long. If only one turnover point is required for the treble filter then S1 and the associated resistors may be omitted.

Response Curve

The gain/frequency response curve of the filter unit is shown in figure 5. As mentioned earlier, with S1 depressed (open) the treble filter turnover point is around 10 kHz, while with S1 closed it is around 25 kHz.

active loudspeaker-crossover filters (1)

Few things can so hold the attention of the serious audiophile as do loudspeakers. This applies with particular strength to those whose fingers always have the experimenter's itch — so that they cannot or will not without reserve accept somebody else's idea of a loudspeaker system. This can lead to the expenditure of considerable sums, if only on wooden panels, and it will sometimes also lead to frayed tempers at home . . .

One of the ways of sinking cash into an existing system is to replace the 'passive' separating ('crossover') filters by 'active' types. This of course involves the provision of a separate power amplifier for every driver in the system.

This article on Active Crossover Filters (ACF's) will describe a universal filter circuit, capable of producing a vast number of filter characteristics.

High-quality loudspeaker systems are invariably designed on the basis of 'divide and rule' principles. The incoming audio spectrum is split up into two, three or even four sub-spectra, each of which is then passed to a loudspeaker specially designed for that particular frequency range. The change-over from one loudspeaker to the next higher in frequency range is accomplished by a complementary filter-pair whose roll-off response-flanks 'cross over' each other at a point some decibels below the 'full power' level. The filter-pairs are therefore called 'crossover filters'.

A loudspeaker system that uses such filters is usually called a 'multiway' system.

When the filter sections are inserted between the single power amplifier and the individual 'drivers' (i.e. loudspeakers

proper), the system is said to have a *passive* filter. Figure 1 illustrates a typical three-way system. The low-to-midrange crossover frequency is f_1 , and the midrange-to-high crossover occurs at f_2 . The representatives of the animal kingdom shown have had their typical calls 'borrowed' to provide a classification of the drivers into the categories low-range (woofer) midrange (squawker) and high-range (tweeter).

The big idea behind the multiway approach is the fact that an optimally-designed 'woofer' is — for basic design reasons — a sub-optimal loudspeaker at higher frequencies. This does not mean that a 'new' design method may not someday produce a first-class full-range driver; it simply hasn't been done yet. The problems to be faced are quite formidable — and a computer is only useful to quickly do the sums that a

human being already *knows how* to do. A multiway system is necessarily more complicated and more expensive to produce than a single-driver system. That is a clear disadvantage. There is however a second objection to the multiway approach — a more fundamental objection: how does one tackle the fact that frequencies near the crossover point are radiated by *both* drivers? The two radiating diaphragms cannot be at the same position in space — although they often can be spaced quite closely — so that 'interferences' between the two radiated waves can cause irregularities in the response characteristics and in the *radiation pattern* of the system.

'Dividing' is one thing; 'ruling' is quite another . . .

Most of the interference effects can be avoided when the two frequency-adjacent drivers are mounted concentrically — one within the other. This is usually no problem, since an optimal tweeter can be made smaller than a woofer. The past has known designs — many of them still very popular — in which a tweeter of one kind or another has been built into a woofer (or, more accurately, a woofer-midrange) cone-loudspeaker. The crossover can be mechanical in nature (as in the 'good old' Philips 9710M), or a more advanced twin-driver-plus-electrical-crossover system can be employed (as in the famous Tannoy Monitor Gold and certain Goodmans and Isophon units).

Passive or active?

Having decided that a good loudspeaker system, at the present state of the art, is going to need at least one crossover filter, we have to decide whether this filter should be a 'passive' or 'active' design. (For our purposes, an 'active' filter is one in which the inductors have been eliminated by the application of capacitors and *amplifiers*).

Figure 1a illustrates a typical passive-filter three-way system. The passive filter is built up with inductors, capacitors and any matching networks that may be necessary (e.g. to reduce the drive to a too-sensitive tweeter). Figure 1b illustrates the bare bones of a three-way passive filter.

One difficulty is immediately apparent. The woofer section requires an inductor in series with the driver voice-coil. The considerable inductance involved means that there will be power loss in the copper-resistance of a many-turn air-cored coil, or else that there will be distortion due to the non-linearity of a low-loss coil that has a ferromagnetic core. Neither of these effects should however be viewed out of proportion: the often-cited effect of the series-resistance on the woofer's electrical damping is completely swamped by the effect that the voice-coil resistance has — and one can design iron-core inductors with a level of distortion that is insignificant compared to that of the actual driver.

1a

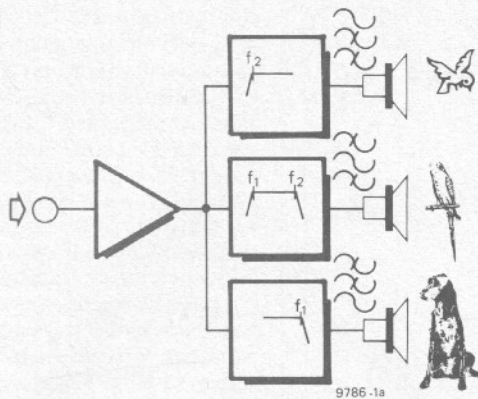

9786-1a

1b

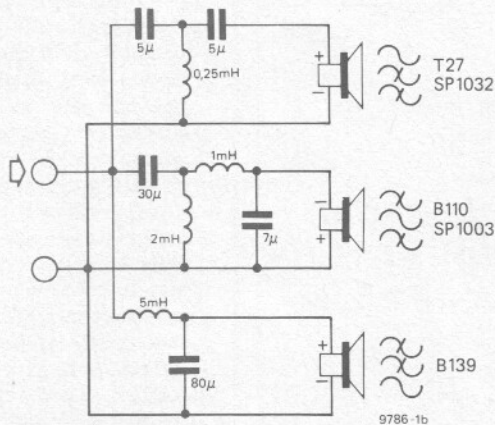

9786-1b

1c

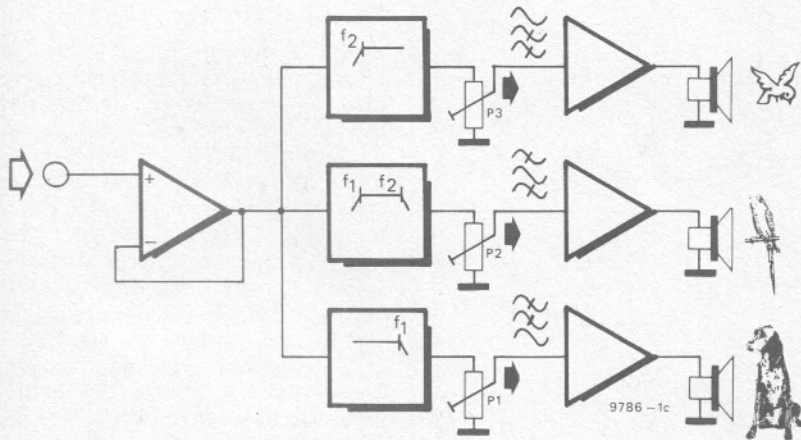

9786-1c

1d

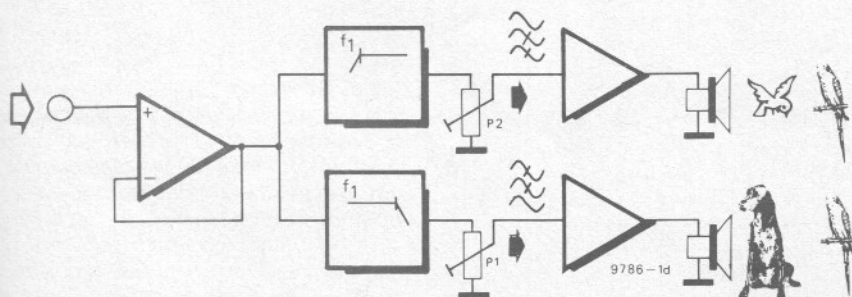

9786-1d

Another source of difficulties is more awkward to eliminate. Normal electrical wave-filters assume a pure-resistance load-termination. When you connect a *loudspeaker* to such a filter the final characteristic may not be quite what you intended – it may even be wildly off. The trick of connecting an RC network across the speaker terminals to compensate the high-frequency rise in impedance (due to the coil's inductance) certainly works and should be better known; but the fun really begins when the speaker impedance contains significant components 'reflected' from the mechanical 'circuit'. That usually happens in the neighbourhood of the driver's fundamental resonance; it can be a very expensive nuisance in the case of midrange and tweeter units that have a resonance (as is usual) at or just below their high-pass crossover frequency.

Now, a well-designed commercial 'passive filter system' will invariably work very well – but that success is due to a combination of design experience and available facilities beyond the reach of the 'do it yourself' audiophile. Although it would be possible to say a great deal more about passive filter arrangements and matching networks, this article is supposed to be about *active* arrangements. Having implied, above, that the amateur is better off tackling his problem with an active system, we must now try to explain how.

Active Crossover Filters

Figure 1c shows the block diagram of a three-way active ('electronic') crossover filter. It is immediately clear that each of the loudspeakers requires its own power amplifier. This need not be so expensive as one might think, since the *total* power required (and hence the amount of mains transformer, reservoir capacitor and heat sink) is not increased by subdividing the amplifier. As a rule, the woofer will need the most powerful amplifier (perhaps 50 . . . 70% of the total), with the midrange unit handling perhaps two-thirds of the remainder. Much will obviously depend on the individual drivers used. When drivers are obtainable with varying rated impedances, the power distribution over the output stages can be achieved by using a single supply voltage together with a low-impedance woofer (say 4 ohm), a mid-range unit of higher

Figure 1a. Block diagram of a three-way system with passive crossover filter.

Figure 1b. As an example: the KEF type DN 12 SP 1004 three-way passive filter.

Figure 1c. Block diagram of an active-filter three-way system.

Figure 1d. An active-filter two-way system.

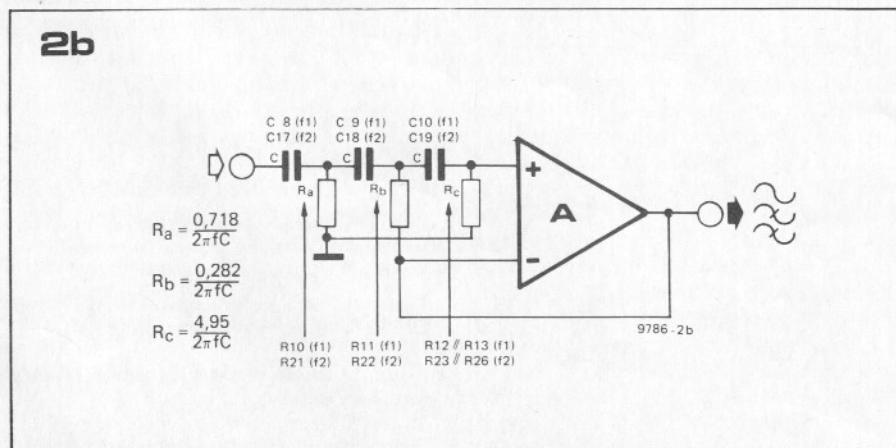
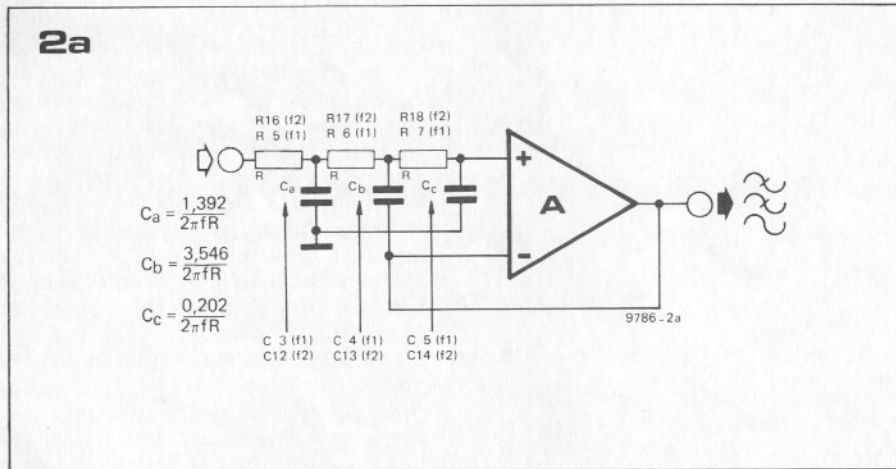
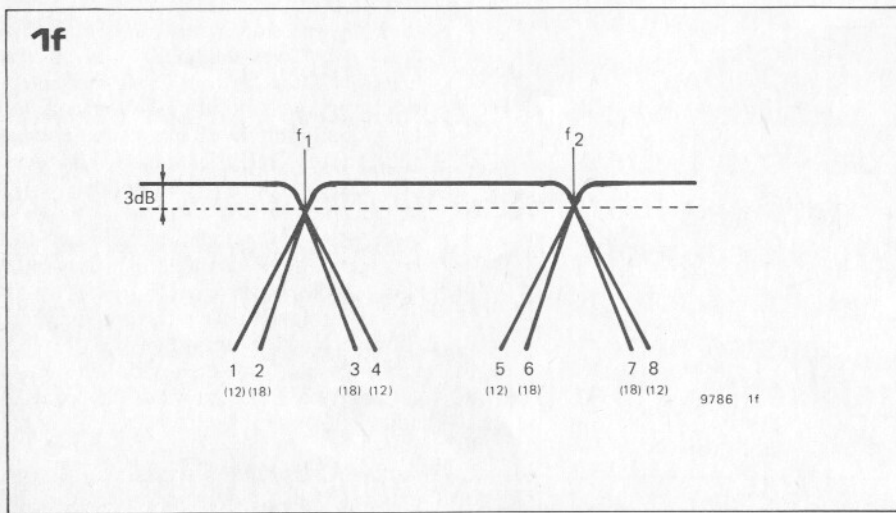
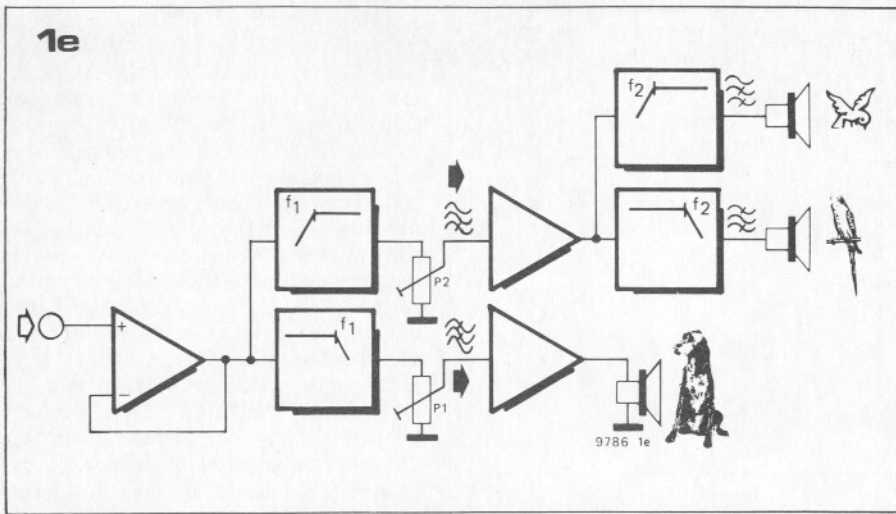

impedance (say 8 ohm) and a tweeter of still higher impedance (15 ohm).

A major advantage of the active-filter approach is the ease with which sensitivity differences between the drivers can be eliminated. In figure 1c this is accomplished by adjustment of the presets P1, P2 and P3. Figure 1d gives a simpler two-way circuit, suitable for use with smaller diameter woofers that are also well-behaved throughout the mid-frequency range. Still another possibility is shown in figure 1e, a 'hybrid' three-way system. In this case the woofer to midrange crossover is done with an active filter and two power amplifiers; the frequency ranges for the midrange and tweeter drivers are however separated by a passive filter set.

What are the other advantages of the active filter approach?

- the design is far more flexible; a change of crossover frequency or drive level can be quickly and conveniently achieved by changing one or two R's and C's or adjusting a preset potentiometer.
- there is no complication in the filter design caused by the awkward termination (the loudspeaker impedance).
- it is relatively simple to produce complicated filter characteristics whenever this is thought desirable or necessary.
- since the power amplifiers will usually be installed in the loudspeaker cabinet, the individual drivers can be protected from overload by suitable choice of the power rating of the amplifier concerned.

The filter circuits

Figure 1f shows a set of filter characteristics, as would be required for a three-way system. The frequencies f1 and f2 are the '-3 dB' points, at which the response curves of a complementary filter-pair actually 'cross over' each other. Half of the power at a crossover frequency is transmitted through each filter of the pair. For a three-way system f1 will frequently lie between 300 and 600 Hz (sometimes as low as 100 Hz, or as high as 800 Hz). The other crossover will then usually be found between 2 kHz and 8 kHz - typically near to 5 kHz. The single crossover in a two-way system is usually between 1 kHz and 3 kHz (typically around 2 kHz).

The slope of the various filters well into their respective 'stop-bands' is a multiple of 6 dB/octave (i.e. 20 dB/decade). The figure 1f curves are drawn for 12 dB/octave (1,4,5,8) and for 18 dB/octave (2,3,6,7). If we assume that either slope may be used for each of the four filters, then there are sixteen possibilities for a three-way filter. It is not always desirable to make the filters of a crossover-pair with the same slope - a so-called *asymmetrical crossover* may be needed when the response of one of the loudspeakers is not flat through the crossover point. Table 1 lists the possibilities.

The last four alternatives apply to two-way systems. We will refer in this article to the single crossover as f_1 .

An electric wave-filter is characterised not only by the 'ultimate slope' of the rolloff curve, well into the 'stop band' but also by the 'sharpness of transition' between the pass-band and the stop-band. A number of Famous Names are associated with a classification of filters into categories with increasing sharpness (once again: note the distinction between *sharpness* and *steepness*).

Almost all loudspeaker crossover filters are of the *Butterworth* 'maximally flat amplitude' type. We will therefore illustrate the workings of the practical circuits by Butterworth responses. When the 'pass-band' is defined as the frequency range up to the -3 dB point (low-pass) or from the -3 dB point upwards (high-pass), then Butterworth gives the lowest possible 'pass-band attenuation' that can be obtained without allowing 'ripples'.

The figures 2, 3 and 4 give the design information for Butterworth low-pass filters ('a' figures) and Butterworth high-pass filters ('b' figures), for ultimate slopes of 18 dB/octave (figure 2), 12 dB/octave (figure 3) and 6 dB/octave (figure 4). The two sets of component numbers refer to the two different crossovers. We will come back to this when referring to the parts list.

The active element in the circuits of figures 2, 3 and 4 is a voltage follower. The best known AC voltage follower is the so-called 'emitter follower'. Since a voltage gain of unity can only be closely approximated by an amplifier with extremely high current gain, the total circuit diagram of figure 5 shows 'super emitter followers' using two transistors each. The derivation of the component values always assumes the use of an ideal voltage follower; any attempt to 'make allowances' is fraught with great uncertainties - and the assumption that a one-transistor follower is ideal is just too optimistic!

This is not the place to go into the

3a

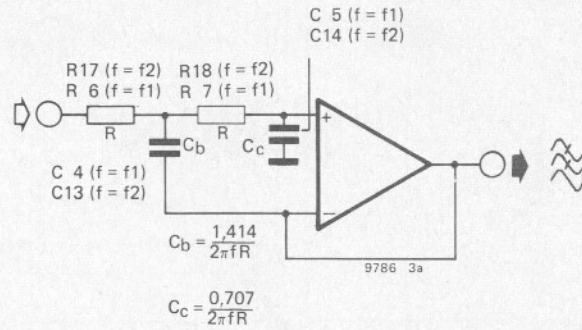

3b

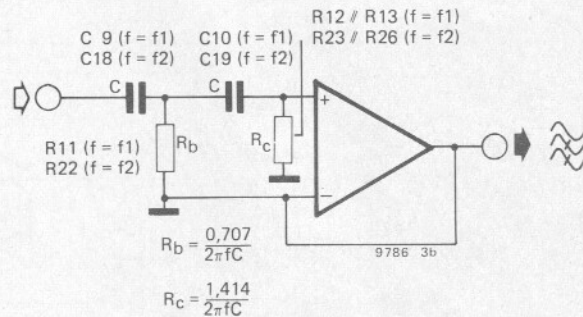

4a

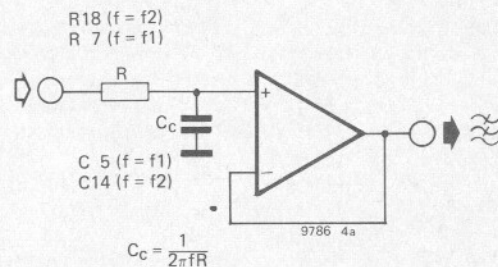

4b

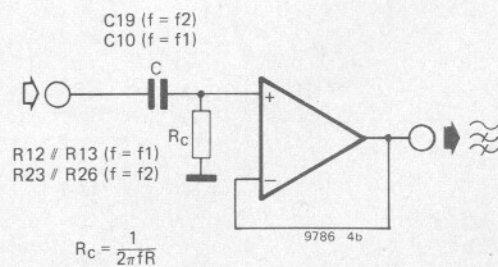

Figure 1e. A hybrid active/passive three-way system.

Figure 1f. A few frequency-response plots, with slopes of 12 and 18 dB/octave and one or two crossovers, as an aid to interpretation of table 1.

Figure 2. Circuit diagram and values for a Butterworth low-pass (a) and high-pass (b) 18 dB/octave filter.

Figure 3. Circuit diagram and values for a Butterworth low-pass (a) and high-pass (b) 12 dB/octave filter.

Figure 4. Circuit diagram and values for a low-pass (a) and high-pass (b) 6 dB/octave filter.

5

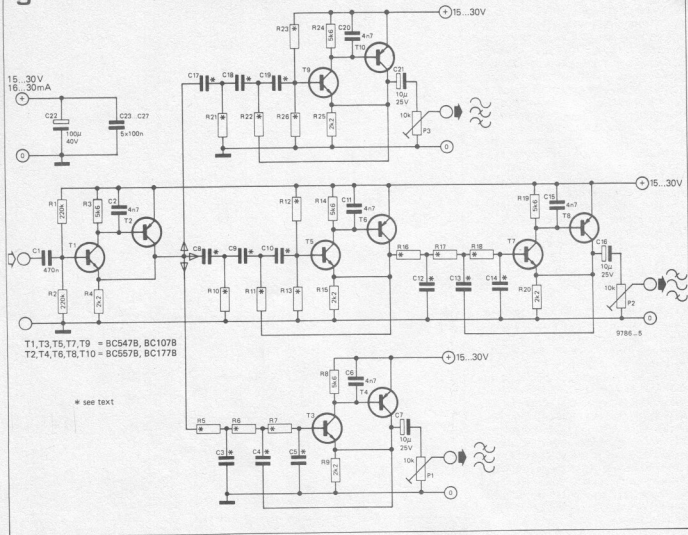

details of the derivation of design formulae.

One practical consequence of the derivations must however be noted here. That is the fact that it is not always possible to design filters in which all the frequency-determining R's and C's have convenient values. We have chosen circuits with either three equal C's (high pass) or three equal R's (low-pass), the other components hopefully coming fairly close to standard E12 values. Filters with low 'Q' values (such as Butterworth) will, fortunately, not immediately go haywire when some of the components are a few percent out. That is not to say that a fussy pot with access to 1% R's and C's should not indulge a craving for 'precision'...

So much for the general aspects of active crossover filter design. It is now time to try working out a specification. One way to tackle this problem is to use a check-list.

- Active filters only (figure 1c or 1d) or hybrid (1e)?
- Three-way or two-way?
- Which speakers?
- How steep the filters?
- Which amplifiers?

Do not try to find complete 'paper' answers to these questions. A great deal will depend on one's individual taste and on whatever happens to be

available. Note that the idea was to find something to *play* with!

There is one fundamental guideline, however. *Loudspeaker are meant to be used for listening to music, not the other way round.* If it sounds right, then never mind what it looks like on paper. Assuming that one's musical taste is reasonable, any discrepancy between the theory and the actual result will usually be due to an oversight or incompleteness in the theory.

It will simplify this story if we introduce two further 'boundary conditions'. Let us assume that (1) we are going to do the job properly - no skimping on parts - and (2) that the reader already knows how to design his enclosure.

The question that should be tackled first is the choice of the loudspeaker to be used. This usually will involve a dig into the manufacturer's literature - or at least a good look into a distributor's catalogue. Unless one knows precisely what one wants, it is a good idea to select a combination recommended by the manufacturer, replacing only the inevitable passive filter by circuits covered in this article. Information on how to construct special woofer enclosures, such as folded horns or 'transmission line' types, can often be found in the literature.















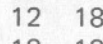
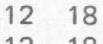

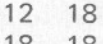

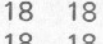

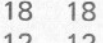
The basic choice between two-way and

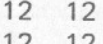
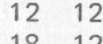
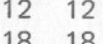
three-way systems is not inevitably one of cost, with three-way always better if you can afford it. On the contrary, some of the best-sounding systems around use a woofer-midrange unit plus a tweeter. These woofer-midrange units do however tend to need rather more than a simple closed-cabinet if they are to do a really good job at the deep-bass end.

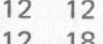
The frequencies and ultimate slopes of the crossover filters can be taken, at least as a starting point, from the parameters of the passive filter recommended by the speaker manufacturer. If one is combining speakers from various sources, then some experiment may be necessary (great fun!). There are one or two guidelines here, more 'don'ts' than 'do's'. In the first place, beware of the 'power handling capacity' ratings of tweeters. It is in the nature of things that their smaller coil systems cannot handle the massive amounts of input power that will not damage woofers. The temptation to suppliers is to quote a high power rating for a tweeter in combination with a specified high-pass filter. The 'power density' of normal music spectra certainly becomes significantly lower as the frequency increases; but this no longer applies when the amplifier is driven into distortion (accidentally or on purpose).

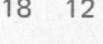
Table 1.

The different possible combinations of symmetrical or asymmetrical crossovers and 12 or 18 dB/octave slopes

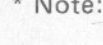
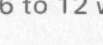
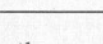
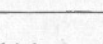
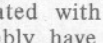
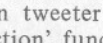
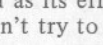
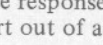
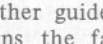
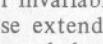
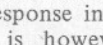
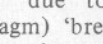
filters slopes at f_1 to be	filters slopes at f_2 to be	combine from figure 1f	refer to figures
 18 12	 18 18	2, 4, 6 & 7	
 18 12	 12 12	2, 4, 5 & 8	
 18 12	 18 12	2, 4, 6 & 8	
 18 12	 12 18	2, 4, 5 & 7	
 12 18	 18 18	1, 3, 6 & 7	
 12 18	 12 12	1, 3, 5 & 8	
 12 18	 18 12	1, 3, 6 & 8	
 12 18	 12 18	1, 3, 5 & 7	
 18 18	 18 18	2, 3, 6 & 7	5 & 6*
 18 18	 12 12	2, 3, 5 & 8	
 18 18	 18 12	2, 3, 6 & 8	
 18 18	 12 18	2, 3, 5 & 7	
 12 12	 18 18	1, 4, 6 & 7	
 12 12	 12 12	1, 4, 5 & 8	7* & 8*
 12 12	 18 12	1, 4, 6 & 8	
 12 12	 12 18	1, 4, 5 & 7	
 18 18	—	2 & 3	9* & 10*
 12 12	—	1 & 4	11* & 12*
 12 18	—	1 & 3	
 18 12	—	2 & 4	

* Note: figures 6 to 12 will be given in part 2.

Put another way: (1) the high-pass filter associated with a certain tweeter will invariably have a 'protection' function as well as its effect on the response and (2) don't try to get a quart out of a pint pot!

The other guideline worth mentioning concerns the fact that a given loudspeaker invariably will have a frequency response extending far higher than the recommended crossover low pass cutoff. The response in the non-recommended range is however usually ragged or 'peaky' due to the cone (or other diaphragm) 'breaking up' into patterns of flexural resonance. This effect will impair the transient response. When a high-pass rolloff is recommended, quite apart from the input power consideration given above, there may be a mechanical limitation on the obtainable sound output in the non-recommended range. This would apply in particular to dome-type tweeters and squawkers.

The filter slope of 6 dB per octave is rarely used, although there is considerable evidence that a slow woofer-midrange rolloff combined with a steeper tweeter slope can give excellent results. It is included here for completeness sake, since 'asymmetrical' crossover filter design really requires access to acoustical measurement facilities.

The amplifiers

We come now to one of the great sources of endless discussion. How many watts need one provide for each loudspeaker? There are many ways of looking at this question, depending on the kind of music you have in mind for instance, or depending on which 'trade-off' you prefer.

We have already noted that the (continuous) dissipation of which a typical tweeter is capable will be less than that of a mid-range and significantly less than that of a woofer. That is simply a question of the physical size of the respective 'motors'. It would seem obvious that the continuous-power ratings of the associated amplifiers should reflect this fact. All one can hope to achieve with some 'reserve watts' is an increased risk of sometime needing a 'reserve speaker'. There is a bit more to it than this; but let us break off at this point.

Every loudspeaker has a certain 'instantaneous' power rating, referring to how much driving force it will handle (quite apart from the dissipation involved) before some moving part hits an end-stop. Since, at a given sound level, the diaphragm amplitude will be greatest at low frequency, the actual useful instantaneous rating will depend

Figure 5. Complete circuit diagram of an active filter set for two symmetrical 18 dB/octave crossovers (three-way).

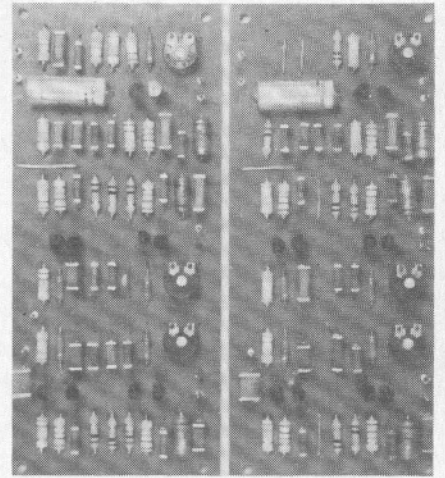

on the choice of (high-pass) crossover frequency. This seems to indicate that the amplifier's 'music power' rating, together with the choice of crossover frequency, should be matched to the (higher) instantaneous rating of the individual speaker. This applies literally to the midrange and to the tweeter; for the woofer something similar applies — but now with the 'box' design setting the high-pass cutoff frequency.

Having taken a look at the *limiting* amounts of power that an amplifier should not be *able to exceed*, we still have no answer to the real question: how much do we need? The answer is, for *normal domestic listening*, 'surprisingly little'. Simply read off from the manufacturer's literature low much input will produce about 96 dB SPL ('sound pressure level) at 1 metre from the loudspeaker (usually specified for free-field-room measurement). It will usually prove that 10 or 20 Watts already offers a very comfortable safety margin!

So much for the design considerations. Next month we will give circuits and printed circuit boards for 6-, 12- and 18 dB/octave filters for use in both 2- and 3- way systems. ■

albar mkll-a bfs

In November 1976 the circuit was described of an ultrasonic intruder alarm, the 'Albar'. By slightly mis-using the ultrasonic transducer it got away with using only one transducer as both transmitter and receiver.

Unfortunately, this system has proved only 80%-90% reliable, i.e. 10%-20% of the units did not work as well as they should. As briefly noted last month, there are two possible solutions to the problem. Both circuits are discussed in greater detail here.

Lab tests have shown that the problems arise from the wide variation in the characteristics of the transducers. Specifically, in the original version the transducer was used as the frequency-determining element for the transmitter oscillator. In practice, most transducers have several possible resonance modes — some in the desired frequency band and some outside. To make matters worse, they are temperature dependent. The result of all this is that the sensitivity can vary between a few inches and 15 to 20 ft. The latter value is what we measured on our original prototypes . . . There are two solutions for those constructors who have built a unit with a sensitivity closer to the former value. The first is a minor modification to the original circuit, still using a single transducer; the second is the Brute Force Solution if all else fails: it uses two transducers, one as transmitter and one as receiver.

The 'old' Albar printed circuit board has been replaced by a new version that can be used both for the modified single-transducer circuit and for the receiver section of the two-transducer circuit. A small additional board is also available for the transmitter circuit of the two-transducer version.

Single-transducer version

Figure 1 gives the circuit of the new single-transducer version. It differs from

the original Albar circuit (Elektor 19, November 1976, p. 1112, figure 6) in several details:

- The numbering of the components has been changed.
- The zener diode has been changed from 9V1 to 10 V, since 10 volt zeners are more readily available.
- One of the T2 emitter resistors has been replaced by a fixed 2.2 mH inductor.
- A supply decoupling capacitor (C13) has been added.
- In the original circuit, the alarm latched on until the reset button was operated. In the new circuit the alarm resets automatically a few seconds after it ceases to detect movement (it operates continuously as long as a moving object is within range). The reset delay depends on the value of C12. If required, the original circuit can also be used: C12 is replaced by a series connection of two diodes (the anode of the first to the collector of T5 and the cathode of the other to C11) and a reset button is added parallel to C11.
- The working voltages of several electrolytics have been changed to more readily available values.

Construction and alignment

The new printed circuit board is shown in figure 4. For this version, only the 'normal' components should be

mounted, *not* the ones shown dotted. Alignment has been considerably simplified by the addition of a headphone output. Components C14 and R17 can be mounted on the board, and any relatively high-impedance headphone or earpiece can be used.

The alignment procedure is as follows:

- connect the unit to a 12 V supply and set P2 at minimum resistance (fully clockwise).
- move a hand to and fro in front of the transducer. This should produce a rising and falling tone in the earpiece.
- set P1 for maximum level (loudness) of this tone.
- now adjust the required sensitivity for the unit with P2.

Two-transducer version

If the first version proves to be less sensitive than desired, or too temperature dependent, it can be extended to a two-transducer version.

The original circuit is modified according to figure 2, to work as a receiver, and a transmitter is added (figure 3). The modifications to the basic circuit are marked with asterisks. Take particular note of the fact that T2 is replaced by a PNP type.

Construction and alignment

The components shown dotted on the component layout for the main board (figure 4) are used in the receiver circuit. This means that where only one possibility is shown, it is valid for both circuits; where a component is shown in full and another is shown dotted, the dotted version is required here. Note however that several of the other component values are also changed, as marked in the circuit and shown in the parts list.

The transmitter and receiver boards with their respective transducers should be mounted in the same box, with the transducers facing out in the same direction. It is advisable to mount the transducers in foam rubber rings, to avoid acoustical coupling through the box. The distance between them should be approximately 2 in. (5 cm).

Point X on the transmitter output is connected to the receiver 'X' input, and the two units are run off a common 12 V supply.

The headphone output is once again used for alignment. Since this unit is more sensitive than the single-transducer version, alignment may be difficult if there are any large reflecting surfaces within 6 ft. (2m) of the transducers.

Figure 1. Modified circuit for the single-transducer version.

Figure 2. Receiver circuit for the two-transducer version. Point 'X' is connected to the transmitter.

1

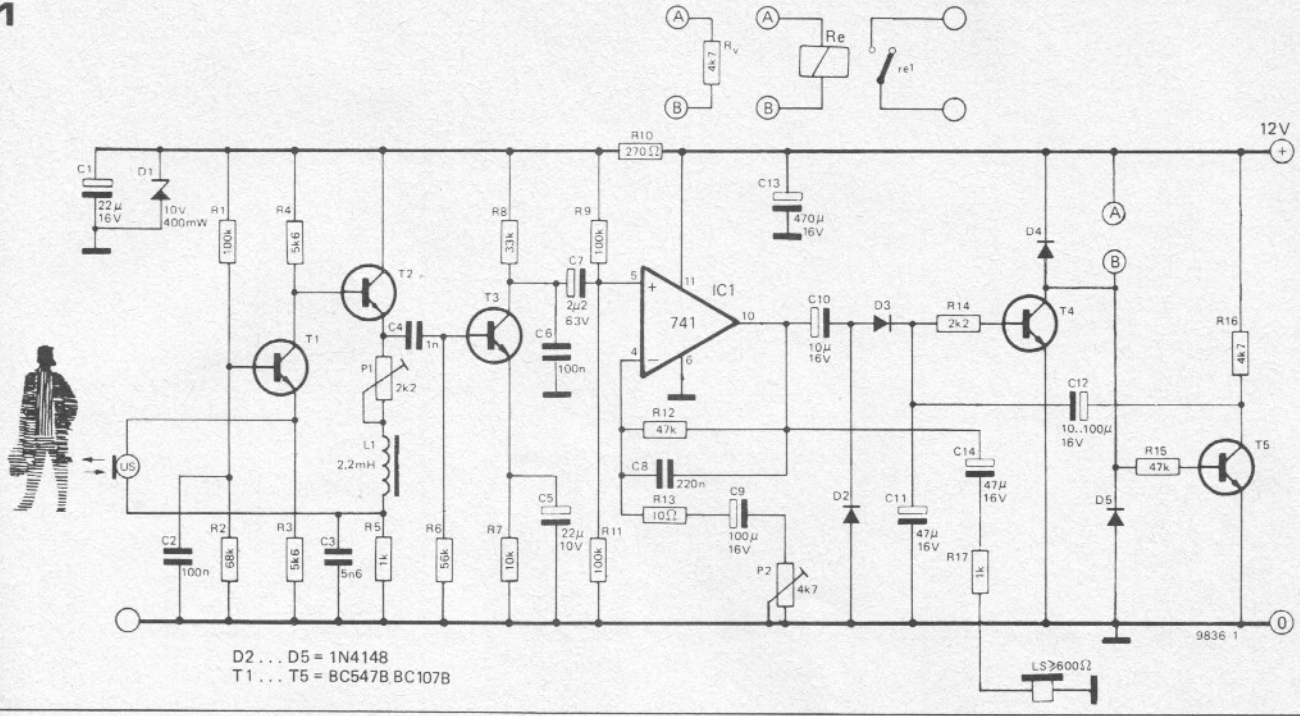

2

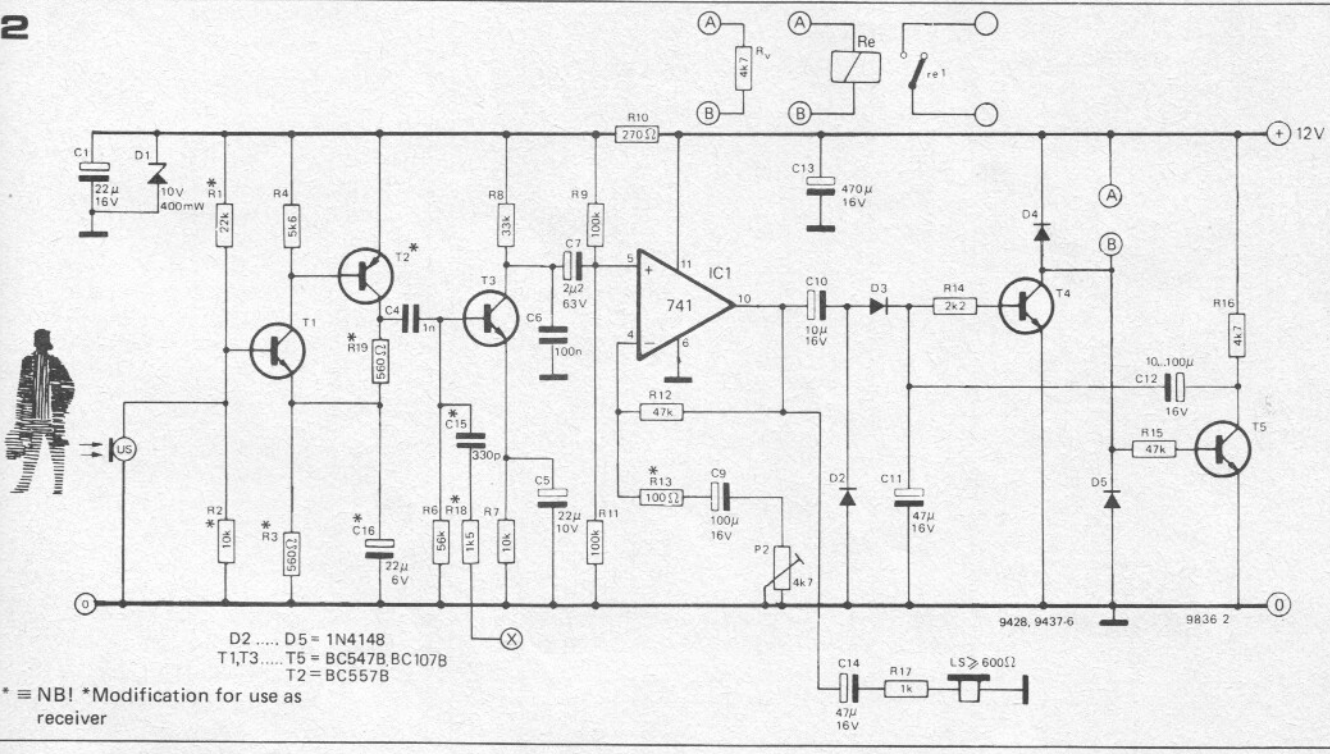

Parts list for single-transducer version (figures 1 and 4)

Resistors:

- R1,R9,R11 = 100 k
- R2 = 68 k
- R3,R4 = 5k6
- R5,R17 = 1 k
- R6 = 56 k
- R7 = 10 k
- R8 = 33 k
- R10 = 270 Ω
- R12,R15 = 47 k
- R13 = 10 Ω

Capacitors:

- C1 = 22 μ/16 V
- C2,C6 = 100 n
- C3 = 5n6
- C4 = 1 n
- C5 = 22 μ/10 V
- C7 = 2μ2/63 V
- C8 = 220 n
- C9 = 100 μ/16 V
- C10 = 10 μ/16 V
- C11,C14 = 47 μ/16 V

- C12 = 10 ... 100 μ/16 V
- C13 = 470 μ/16 V

Semiconductors:

- IC1 = 741
- T1 ... T5 = BC547 B or BC107 B
- D1 = 10 V/400 mW
- D2 ... D5 = 1N4148

Sundries:

- L1 = 2.2 mH
- US = Murata MA 40L 1R or MA 40L 1S
- LS = headphone or earpiece (R ≥ 600 Ω)
- Re = 12 V/20 mA relay

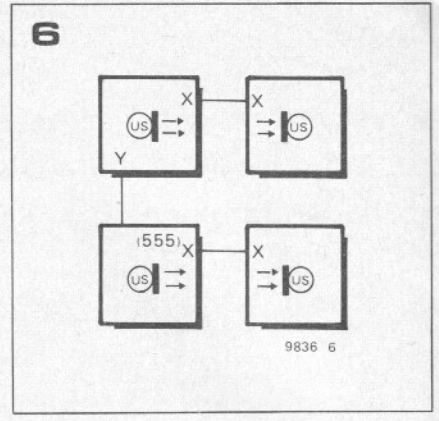
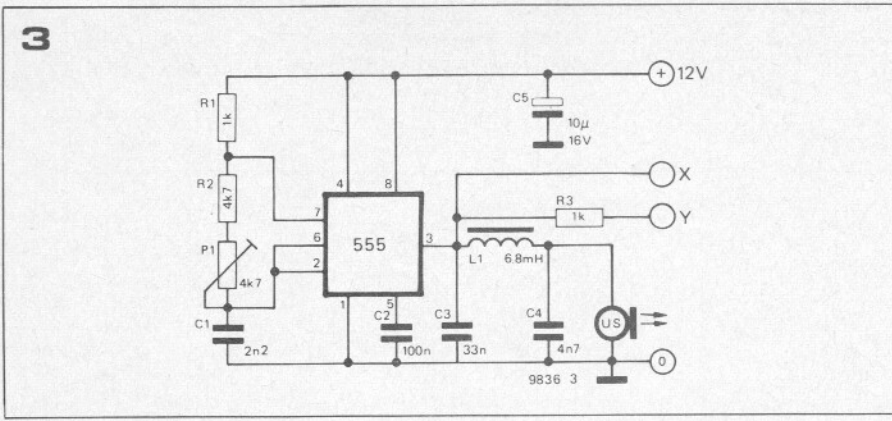

Figure 3. Transmitter for the two-transducer version.

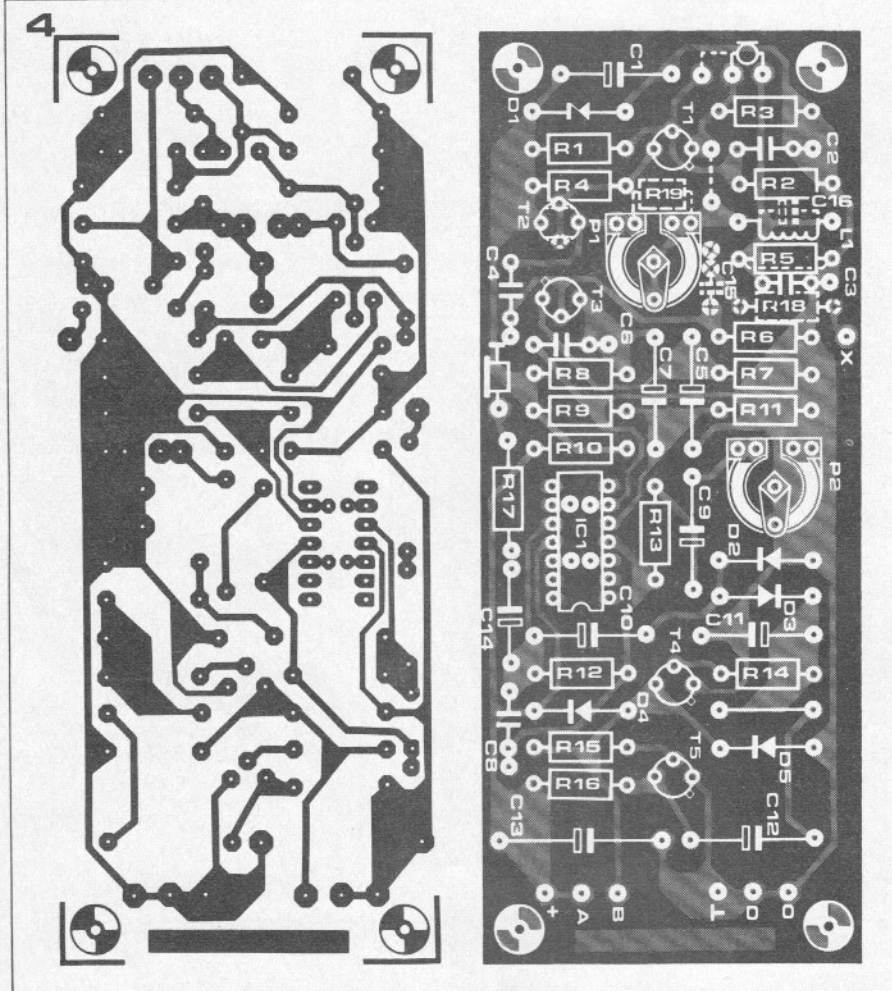
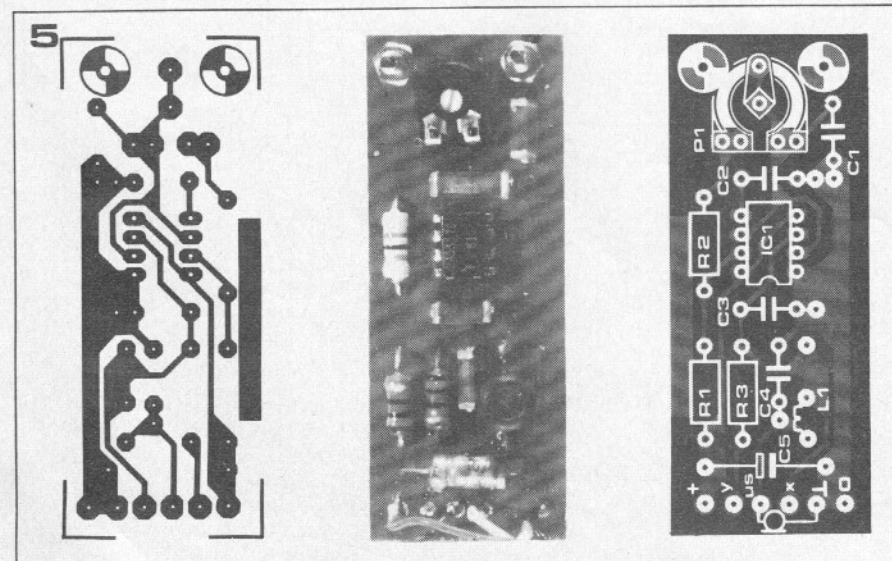

Figure 4. Printed circuit board and component layout for both figure 1 and figure 2. (EPS 9815-1).

Figure 5. Printed circuit board and component layout for the transmitter in the two-transducer system. (EPS 9815-2).

Figure 6. The number of transmitters (or receivers, for that matter) can be extended at will, provided the transmitters are arranged to run at the same frequency.



The procedure is as follows:

- set P2 at *maximum* resistance (fully anti-clockwise).
- as before, move a hand to and fro in front of the transducers, and set P1 on the transmitter board for maximum level of the tone in the earpiece.
- adjust P2 until the correct sensitivity is obtained.

One final tip: in some cases one transducer is better than the other, so it is worth while interchanging them to see which one is better for the receiver.

Three-transducer version . . .

In theory it is possible to extend the two-transducer version by adding one or more extra transmitters. For this it is essential that they should all oscillate at the same frequency. Although we have not tried this in practice, the principle is relatively simple. Output 'Y' from one of the transmitters (the 'master' oscillator) is used to drive or synchronise the other(s).

There are two ways to do this. Provided the cable capacitance of the link between the transmitters is not too high, components R1, R2, P1 and C1 of the 'slave' transmitter can be omitted and output 'Y' from the master is fed to pins 2 and 6 of the IC on the slave transmitter. Alternatively, all components are mounted on the 'slave' board, but the lower end of C2 is disconnected from supply common and the 'Y' signal is fed in via this capacitor to pin 5 of the IC. P1 on the 'slave' transmitter is now adjusted for 'zero beat' in the earpiece.

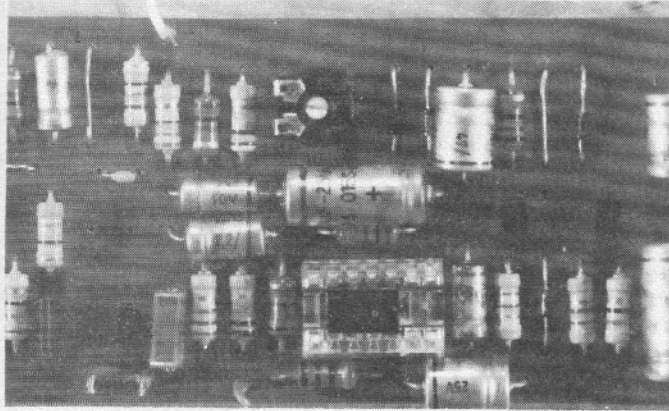

Parts list for receiver (figures 2 and 4)

Resistors:

R1 = 22 k
R2, R7 = 10 k
R3, R19 = 560 Ω
R4 = 5k6
R6 = 56 k
R8 = 33 k
R9, R11 = 100 k
R10 = 270 Ω
R12, R15 = 47 k
R13 = 100 Ω
R14 = 2k2
R16, R_V = 4k7
R17 = 1 k
R18 = 1k5
P2 = 4k7

Capacitors:

C1 = 22 μ /16 V
C4 = 1 n
C5 = 22 μ /10 V

C6 = 100 n
C7 = 2 μ 2/63 V
C9 = 100 μ /16 V
C10 = 10 μ /16 V
C11, C14 = 47 μ /16 V
C12 = 10 . . . 100 μ /16 V
C13 = 470 μ /16 V
C15 = 330 p
C16 = 22 μ /6 V

Semiconductors:

IC1 = 741
T1, T3 . . . T5 = BC547B or BC107B
T2 = BC557B or BC177B
D1 = 10 V/400 mW
D2 . . . D5 = 1N4148

Sundries:

US = Murata MA 40L 1R or MA 40L 1S
LS = headphone or earpiece (R \geq 600 Ω)
Re = 12 V/20 mA relay

Parts list for transmitter (figures 3 and 5)

Resistors:

R1, R3 = 1 k
R2 = 4k7
P1 = 4k7

Capacitors:

C1 = 2n2
C2 = 100 n
C3 = 33 n
C4 = 4n7
C5 = 10 μ /16 V

Semiconductors:

IC = 555

Sundries:

L1 = 6.8 mH
US = Murata MA 40L 1R or MA 40L 1S



Conductive spray paint

Chomerics' 4900 conductive paint is a one-component, air-drying coating which will provide effective EMI attenuation when applied in a 2-mil coating on non-conductive enclosures. It can also be used to improve the shielding characteristics of metal enclosures by reducing the contact resistance of flanges; to create or improve grounding surfaces; to fill minute voids in porous metal castings; and to make conductive patterns on nonconductive substrates. This paint is a solvent-based system consisting of a silver filler in an acrylic resin. It is specifically intended for spray-application, but can also be applied by dipping or brushing. Regardless of application method, 4900 must be agitated often to prevent the dense filler from settling out and causing resin-rich areas in the coated surface. Coverage is approximately 70 sq. ft. per pound in a 1-mil thickness. When used as a shield, the 2-mil thickness should be built up in 2-3 applications, allowing 15-20 minutes after each application for solvent evaporation. Optimum properties are developed after a

2-hour room-temperature drying period, which can be accelerated to 1 hour at 170°F. When elevated-temperature drying is used, the coating should first be allowed to dry tack-free for 20 minutes at room temperature to avoid solvent entrapment. For evaluation and prototype purposes, 4900 is available in 6 oz. aerosol cans. However, for best control of uniformity and thickness, conventional spray equipment should be used. A thicker, non-sprayable version of 4900 is also available, and is especially useful for brushing on areas difficult to coat with a spray.

Chomerics,
66 Rue la Boétie, 75008 Paris,
France

(449 M)

Recording audiometer

An audiometer for statutory audiometry in connection with health investigations has been developed by Brüel & Kjaer. Designated Type 1800, the recording Bekesy-type audiometer provides a pure tone signal (continuous or pulsed) at 7 different frequencies from 500 Hz to 8000 Hz and records the patient's response automatically. The audiometer is basically an x-y recorder - the x-axis representing the test-frequency and the y-axis representing the hearing-threshold of the patient (in the range - 10 dB to + 90 dB HL) as registered with the help of a patient-operated handswitch. The patient is instructed to hold the button on the handswitch pressed down as long as he hears the signal in the matched earphones, thus causing the signal-level to decrease, and to release the button when he no longer hears the signal. In this way he tracks his own threshold level. Remote control facilities and lamp indication of patient response outside normal range makes the audiometer ideal for group testing.

Brüel & Kjaer,
23 Linde allé, DK-2850 Naerum,
Denmark

(452 M)

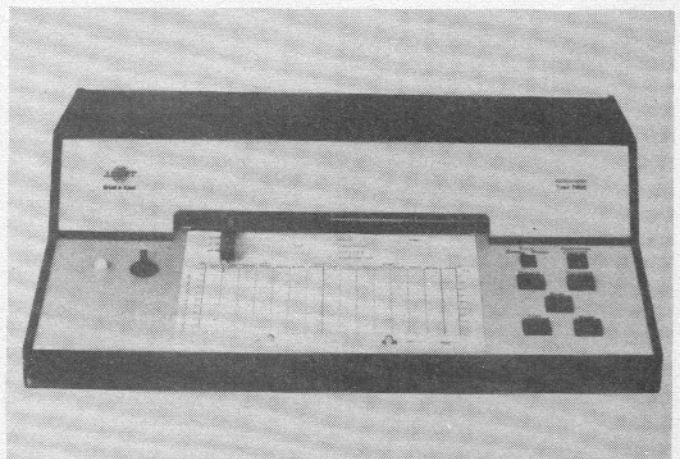

15 - 240 WATTS!

HY 5 preamplifier

The HY5 is a mono hybrid amplifier ideally suited for all applications. All common input functions (mag Cartridge, tuner, etc.) are catered for internally, the desired function is achieved either by a multi-way switch or direct connection to the appropriate pins. The interval volume and tone circuits merely require connecting to external potentiometers (not included). The HY5 is compatible with all I.L.P. power amplifiers and power supplies. To ease construction and mounting a P.C. connector is supplied with each pre-amplifier.

FEATURES: Complete pre-amplifier in single pack - Multi function equalization - Low noise - Low distortion - High overload - Two simply combined for stereo.

APPLICATIONS: Hi-Fi - Mixers - Disco - Guitar and Organ - Public address.

SPECIFICATIONS:

INPUTS: Magnetic Pick-up 3 mV, Ceramic Pick-up 30 mV, Tuner 100 mV, Microphone 10 mV, Auxiliary 3-100 mV; input impedance 47 k Ω at 1 kHz.

OUTPUTS: Tape 100 mV, Main output 500 mV R.M.S.

ACTIVE TONE CONTROLS: Treble \pm 12 dB at 10 kHz; Bass \pm at 100 Hz.

DISTORTION: 0.1% at 1 kHz, Signal/Noise Ratio 68 dB.

OVERLOAD: 38 dB on Magnetic Pick-up. **SUPPLY VOLTAGE:** \pm 16-50 V.

Price £ 5.22 + 65 p. VAT P&P free.

HY5 Mounting Board B1 48 p + 6 p VAT P&P free.

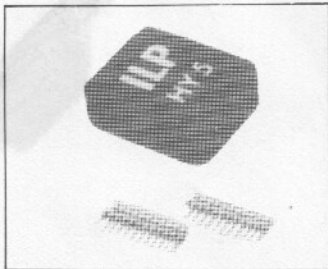

HY 30 15 Watts into 8 Ω

The HY30 is an exciting New kit from I.L.P. it features a virtually indestructible I.C. with short circuit and thermal protection. The kit consists of 1 C., heatsink, P.C. board, 4 resistors, 6 capacitors, mounting kit, together with easy to follow construction and operating instructions. This amplifier is ideally suited to the beginner in audio who wishes to use the most up-to-date technology available.

FEATURES: Complete Kit - Low Distortion - Short, Open and Thermal Protection - Easy to Build.

APPLICATIONS: Updating audio equipment - Guitar practice amplifier - Test amplifier - audio oscillator.

SPECIFICATIONS:

OUTPUT POWER: 15 W R.M.S. into 8 Ω . **DISTORTION:** 0.1% at 15 W.

INPUT SENSITIVITY: 500 mV. **FREQUENCY RESPONSE:** 10 Hz-16 kHz -3 dB.

SUPPLY VOLTAGE: \pm 18 V.

Price £ 5.22 + 65 p. VAT P&P free.

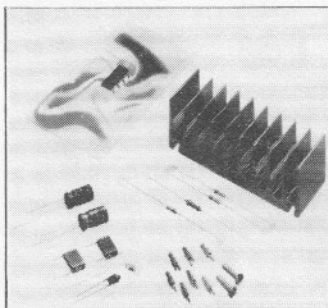

HY 50 25 Watts into 8 Ω

The HY50 leads I.L.P.'s total integration approach to power amplifier design. The amplifier features an integral heatsink together with the simplicity of no external components. During the past three years the amplifier has been refined to the extent that it must be one of the most reliable and robust High Fidelity modules in the World.

FEATURES: Low Distortion - Integral Heatsink - Only five connections - 7 Amp output transistors - No external components.

APPLICATIONS: Medium Power Hi-Fi systems - Low power disco - Guitar amplifier.

SPECIFICATIONS:

INPUT SENSITIVITY: 500 mV.

OUTPUT POWER: 25 W R.M.S. into 8 Ω . **LOAD IMPEDANCE:** 4-16 Ω . **DISTORTION:** 0.04% at 25 W at 1 kHz.

SIGNAL/NOISE RATIO: 75 dB. **FREQUENCY RESPONSE:** 10 Hz-45 kHz -3 dB.

SUPPLY VOLTAGE: \pm 25 V. **SIZE:** 105x50x25 mm.

Price £ 6.82 + 85 p. VAT P&P free.



HY 120 60 Watts into 8 Ω

The HY120 is the baby of I.L.P.'s new high power range, designed to meet the most exacting requirements including load line and thermal protection this amplifier sets a new standard in modular design.

FEATURES: Very low distortion - Integral heatsink - Load line protection - Thermal protection - Five connections - No external components.

APPLICATIONS: Hi-Fi - High quality disco - Public address - Monitor amplifier - Guitar and organ.

SPECIFICATIONS:

INPUT SENSITIVITY: 500 mV.

OUTPUT POWER: 60 W R.M.S. into 8 Ω . **LOAD IMPEDANCE:** 4-16 Ω . **DISTORTION:** 0.04% at 60 W at 1 kHz.

SIGNAL/NOISE RATIO: 90 dB. **FREQUENCY RESPONSE:** 10 Hz-45 kHz -3 dB. **SUPPLY VOLTAGE:** \pm 35 V.

SIZE: 114x50x85 mm.

Price £ 15.84 + £1.27 VAT P&P free.

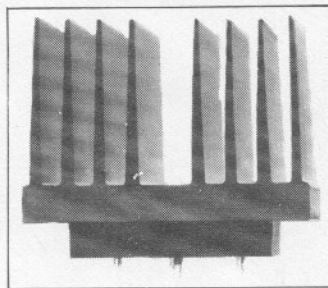

HY 200 120 Watts into 8 Ω

The HY200 now improved to give an output of 120 Watts has been designed to stand the most rugged conditions such as disco or group while still retaining true Hi-Fi performance.

FEATURES: Thermal shutdown - Very low distortion - Load line protection - Integral heatsink - No external components.

APPLICATIONS: Hi-Fi - Disco - Monitor - Power slave - Industrial - Public Address.

SPECIFICATIONS:

INPUT SENSITIVITY: 500 mV.

OUTPUT POWER: 120 W R.M.S. into 8 Ω . **LOAD IMPEDANCE:** 4-16 Ω . **DISTORTION:** 0.05% at 100 W at 1 kHz.

SIGNAL/NOISE RATIO: 96 dB. **FREQUENCY RESPONSE:** 10 Hz-45 kHz -3 dB. **SUPPLY VOLTAGE:** \pm 45 V.

SIZE: 114x100x85 mm.

Price £ 23.32 + £1.87 VAT P&P free.

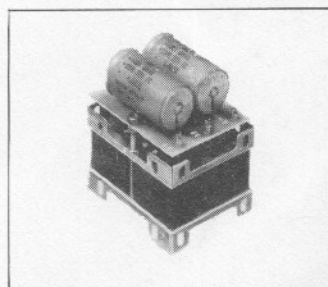

HY 400 240 Watts into 4 Ω

The HY400 is I.L.P.'s 'Big Daddy' of the range producing 240 W into 4 Ω ! It has been designed for high power disco or public address applications. If the amplifier is to be used at continuous high power levels a cooling fan is recommended. The amplifier includes all the qualities of the rest of the family to lead the market as a true high power hi-fidelity power module.

FEATURES: Thermal shutdown - Very low distortion - Load line protection - No external components.

APPLICATIONS: Public address - Disco - Power slave - Industrial.

SPECIFICATIONS:

OUTPUT POWER: 240 W R.M.S. into 4 Ω . **LOAD IMPEDANCE:** 4-16 Ω . **DISTORTION:** 0.1% at 240 W at 1 kHz.

SIGNAL/NOISE RATIO: 94 dB. **FREQUENCY RESPONSE:** 10 Hz-45 kHz -3 dB. **SUPPLY VOLTAGE:** \pm 45 V.

INPUT SENSITIVITY: 500 mV. **SIZE:** 114x100x85 mm.

Price £ 32.17 + £ 2.57 VAT P&P free.

power supplies

PSU36 suitable for two HY30's £ 5.22 plus 65 p VAT P&P free.
PSU50 suitable for two HY50's £ 6.82 plus 85 p VAT P&P free.
PSU70 suitable for two HY120's £ 13.75 plus £ 1.10 VAT P&P free.
PSU90 suitable for one HY200 £ 12.65 plus £ 1.01 VAT P&P free.
PSU180 suitable for two HY200's or one HY400 £ 23.10 plus £ 1.85 VAT P&P free.

TWO YEARS' GUARANTEE ON ALL OF OUR PRODUCTS

I.L.P. Electronics Ltd
Crossland House
Nackington,
Canterbury
Kent CT4 7AD
Tel (0227) 63218

Please Supply _____
Total Purchase Price _____
I Enclose Cheque Postal Orders Money Order
Please debit my Access account Barclaycard account
Account number _____
Name & Address _____
Signature _____

MAPLIN



The only organ you can build in stages and tailor to your requirements as you go along – and at each stage you'll have a fully working instrument! We haven't got the gimmicks (yet – they're coming soon), but we have got the most beautiful sounds – you won't find them on any organ less than twice our price. So get our MES50 series leaflets now! 65p buys the three available so far.



This high quality Graphic Equaliser will enhance even the most sophisticated system at a fraction of the cost of a ready-made equaliser of equal quality. You can get all the parts from us (except woodwork) including drilled and printed metalwork. Construction details in our leaflet: 15p.

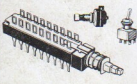

We stock a wide range of switches including a really low priced high quality interlocking push-button switch system, which is extremely versatile. We've got toggle switches, slide switches, push switches, rotary switches – there are dozens to choose from, but it's only a tiny part of our fantastic range.

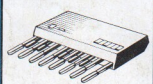

A completely self-contained pedal unit. 13-note, 2-octave range, 4 organ stops. It can be added to any organ! A really unusual extra is the bass guitar stop which uses four envelope shapers to give a real bass guitar sound. A must for the solo guitarist. Full construction details in our catalogue – post the coupon below now!

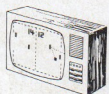

Play fascinating games NOW on your own t.v. in your own living room. The kids will think it's magic when the scores pop up on the screen. Lay your bets – anyone could win – with Maplin's prices everyone can win. Get the May edition of Electronics Today International now – then get all the parts from us at a remarkably low price (I.C. alone £11.99). All prices include VAT and P&P.

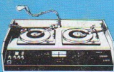

IT'S A FANTASTIC BESTSELLER!

216 big (11" x 8") pages! Over a thousand illustrations! Over 30 pages of complete projects to build! Thousands and thousands of useful components described and illustrated! No wonder it's a bestseller!

DON'T MISS OUT! SEND 50p NOW!

POST THIS COUPON NOW FOR YOUR COPY OF OUR CATALOGUE PRICE 50p

Please rush me a copy of your 216 page catalogue by return of post. I enclose 50p, but understand that if I am not completely satisfied I may return the catalogue to you within 14 days and have my 50p refunded immediately.

NAME _____

ADDRESS _____



MAPLIN ELECTRONIC SUPPLIES

P.O. BOX 3 RAYLEIGH ESSEX SS6 8LR

Telephone: Southend (0702) 715155

Shop: 284, London Road, Westcliff-on-Sea, Essex

(Closed on Monday) Telephone: Southend (0702) 47379