

up-to-date electronics for lab and leisure

ELEKTOR 24

April 1977 45p / USA \$ 1.50

Service Size

Slotless model car track

LED VU/PPM

Morse decoder with DDLL(2)



ELEKTOR

Editor : W. van der Horst

Deputy editor : P. Holmes

Technical editors : J. Barendrecht
G.H.K. Dam
E. Krepelsauer
G.H. Nachbar
Fr. Scheel
K.S.M. Walraven

Art editor : C. Sinke

Subscriptions : Mrs. A. van Meyel

U.K. editorial offices, administration and advertising:
6, Stour Street, Canterbury CT1 2XZ, Kent, U.K.
Tel.: Canterbury (0227) 54430. Telex: 965504.

Bank: 1. Midland Bank Ltd., Canterbury, A/C no. 11014587,
Sorting code 40-16-11, Giro no. 3154254.
2. U.S.A. and Canada: c/o World Way Postal Center
P.O. Box 80689, Los Angeles, Cal. 90080,
A/C no. 12350-04207.

Assistant Manager and Advertising : R.G. Knapp
Editorial : T. Emmens

Elektor is published monthly on the third Friday of each month.

- U.K. and all countries except the U.S.A. and Canada:
Cover price £ 0.45.
Number 27/28 (July/August), is a double issue, 'Summer Circuits', price £ 0.90.
Single copies (incl. back issues) are available by post from our Canterbury office, at £ 0.60 (surface mail) or £ 0.95 (air mail).
Subscriptions for 1977, January to December incl., £ 6.25 (surface mail) or £ 11.— (air mail).
Subscriptions from May to December 1977, £4.15 (surface mail).
- For the U.S.A. and Canada:
Cover price \$ 1.50.
Number 27/28 (July/August), is a double issue, 'Summer Circuits', price \$ 3.—.
Single copies (incl. back issues) \$ 1.50 (surface mail) or \$ 2.25 (air mail).
Subscriptions for 1977, January to December incl., \$ 18.— (surface mail) or \$ 27.— (air mail).
Subscriptions from May to December 1977, \$12.00 (surface mail).
All prices include post & packing.

Change of address. Please allow at least six weeks for change of address. Include your old address, enclosing, if possible, an address label from a recent issue.

Letters should be addressed to the department concerned:
TQ = Technical Queries, ADV = Advertisements, SUB = Subscriptions;
ADM = Administration; ED = Editorial (articles submitted for publication etc.); EPS = Elektor printed circuit board service.
For technical queries, please enclose a stamped, addressed envelope.

The circuits published are for domestic use only. The submission of designs or articles to Elektor implies permission to the publishers to alter and translate the text and design, and to use the contents in other Elektor publications and activities. The publishers cannot guarantee to return any material submitted to them. All drawing, photographs, printed circuit boards and articles published in Elektor are copyright and may not be reproduced or imitated in whole or part without prior written permission of the publishers.

Patent protection may exist in respect of circuits, devices, components etc. described in this magazine.
The publishers do not accept responsibility for failing to identify such patent or other protection.

National advertising rates for the English edition of Elektor and/or international advertising rates for advertising at the same time in the English, Dutch and German issues are available on request.

Distribution: Spotlight Magazine Distributors Ltd.,
Spotlight House 1, Bentwell Road, Holloway, London N7 7AX.

Copyright © 1977 Elektor publishers Ltd — Canterbury.

Printed in the Netherlands.

DECODEUR

What is a TUN?
What is 10 n?
What is the EPS service?
What is the TQ service?
What is a missing link?

Semiconductor types

Very often, a large number of equivalent semiconductors exist with different type numbers. For this reason, 'abbreviated' type numbers are used in Elektor wherever possible:

- '741' stands for μ A741, LM741, MC741, MIC741, RM741, SN72741, etc.
- 'TUP' or 'TUN' (Transistor, Universal, PNP or NPN respectively) stands for any low frequency silicon transistor that meets the specifications listed in Table 1. Some examples are listed below.
- 'DUS' or 'DUG' (Diode, Universal, Silicon or Germanium respectively) stands for any diode that meets the specifications listed in Table 2.
- 'BC107B', 'BC237B', 'BC547B' all refer to the same 'family' of almost identical better-quality silicon transistors. In general, any other member of the same family can be used instead. (See below.)

For further information, see 'TUP, TUN, DUG, DUS', Elektor 21, p. 160.

Table 1. Minimum specifications for TUP (PNP) and TUN (NPN).

V _{CEO} , max	20V
I _C , max	100 mA
h _{FE} , max	100
P _{tot} , max	100 mW
f _T , min	100 MHz

Some 'TUN's are: BC107, BC108 and BC109 families; 2N3856A, 2N3859, 2N3860, 2N3904, 2N3947, 2N4124. Some 'TUP's are: BC177 and BC178 families; BC179 family with the possible exception of BC159 and BC179; 2N2412, 2N2521, 2N3906, 2N4126, 2N4291.

Table 2. Minimum specifications for DUS (silicon) and DUG (germanium).

	DUS	DUG
V _R , max	25V	20V
I _F , max	100mA	35mA
I _R , max	1 μ A	100 μ A
P _{tot} , max	250mW	250mW
C _D , max	5pF	10pF

Some 'DUS's are: BA127, BA217, BA218, BA221, BA222, BA317, BA319, BA313, BAY61, 1N934, 1N4148.
Some 'DUG's are: OA85, OA91, OA95, AA116.

BC107 (-8, -9) families:

BC107 (-8, -9), BC147 (-8, -9), BC207 (-8, -9), BC237 (-8, -9), BC317 (-8, -9), BC347 (-8, -9), BC547 (-8, -9), BC171 (-2, -3), BC182 (-3, -4), BC382 (-3, -4), BC437 (-8, -9), BC414

BC177 (-8, -9) families:

BC177 (-8, -9), BC157 (-8, -9), BC204 (-5, -6), BC307 (-8, -9), BC320 (-1, -2), BC350 (-1, -2), BC557 (-8, -9), BC251 (-2, -3), BC212 (-3, -4), BC512 (-3, -4), BC261 (-2, -3), BC416.

Resistor and capacitor values

When giving component values, decimal points and large numbers of zeros are avoided wherever possible. The decimal point is usually replaced by one of the following international abbreviations:

p (pico-) = 10⁻¹²n (nano-) = 10⁻⁹ μ (micro-) = 10⁻⁶m (milli-) = 10⁻³k (kilo-) = 10³M (mega-) = 10⁶G (giga-) = 10⁹

A few examples:

Resistance value 2k7: this is

2.7 k Ω , or 2700 Ω .

Resistance value 470: this is

4.7 pF, or 4700 pF.

Capacitance value 4p7: this is

4.7 pF, or 4700 pF.

Capacitance value 10 n: this is

10,000 pF or .01 μ F, since 1 n is10⁻⁹ farads or 1000 pF.

Mains voltages

No mains (power line) voltages are listed in Elektor circuits. It is assumed that our readers know what voltage is standard in their part of the world!

Readers in countries that use 60 Hz should note that Elektor circuits are designed for 50 Hz operation. This will not normally be a problem; however, in cases where the mains frequency is used for synchronisation some modification may be required.

Technical services to readers -

- EPS service. Many Elektor articles include a lay-out for a printed circuit board. Some — but not all — of these boards are available ready-cut and predrilled. The 'EPS print service list' in the current issue always gives a complete list of available boards.
- Technical queries. Members of the technical staff are available to answer technical queries (relating to articles published in Elektor) by telephone on Mondays from 14.00 to 16.30. Letters with technical queries should be addressed to: Dept. T.Q. Please enclose a stamped, self-addressed envelope; readers outside U.K. please enclose an IRC instead of stamps.
- Missing link. Any important modifications to, additions to, improvements on or corrections in Elektor circuits are generally listed under the heading 'Missing Link' at the earliest opportunity.

CONTENTS

24 Volume 3
Number 4

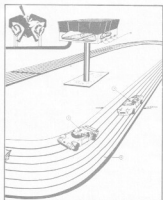

In the slotless model car track the infra-red LEDs are mounted on a column in the centre of the race track, while the photodiodes are mounted on the roofs of the cars.

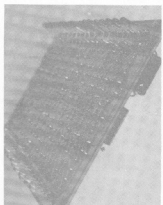

In the LED VU/PPM columns of up to 20 LEDs are used in a thermomater-type display.

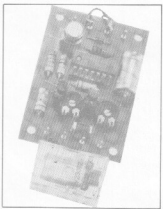

The simple auto slide changer senses the drop in signal level of the commentary when the commentator stops speaking for more than one second, and uses this information to control the slide projector.

up-to-date electronics for lab and leisure
ELEKTOR 24
ISSN 0171-4617 USA \$ 3.00

Slotless model car track
LED VU/PPM
Morse decoder with DLL(2)



LEDs, electronics and model cars are the main ingredients of the slotless model car track.

advertiser's index 4-08

selektor 4-12

formant — the elektor synthesizer 4-14

slotless model car track (1) 4-15

Model car race tracks have been popular for many years. However, all of the commercially available tracks have the disadvantage that the car is guided by a pin which engages in the slotted track, and the 'driver' controls only the speed of the vehicle. In the Elektor race track the cars are freed from this restraint and both speed and steering are remotely controlled using an infra-red link.

morse decoder with dll (2) — E.H. Leefsa 4-20

The first part of this article dealt with the general operating principles of the morse decoder. In this part the complete circuit is considered in detail, together with some methods of displaying the decoded message.

digisplay on board 4-29

LED VU/PPM 4-32

VU (Volume Unit) meters and PPMs (Peak Programme Meters) are used widely in the recording industry and by the amateur to monitor audio signal levels. In this circuit the conventional moving coil indicator is replaced by a column of LEDs that indicate the signal level.

signal injector — J.W. van Beek 4-41

simple auto slide changer — W. Fröse 4-42

hinil drive for light sequencer — H.P. Blomeyer 4-45

variometer tuner (2) 4-46

This FM receiver uses a double conversion i.f. and PLL demodulator, and offers performance equal to the best commercially available tuners.

albar mk II — a b.f.s. 4-54

market 4-55

formant= the elektor synthesizer

Visitors to last year's Hi-Fi exhibition in Duesseldorf, W-Germany, will have noticed something special on the Elektor stand: the first public demonstration of the Elektor synthesizer.

The photo's will give some idea of what it looks like: a keyboard and a fair-sized box covered with knobs and patch-cords.

It is more difficult to give an impression of the sounds coming out of the 'Formant'. A reasonably skilled musician (or should we say 'operator'?) can produce any number of radically different sounds, creating a totally new musical 'experience'. Suffice it to say that the Formant has the same capabilities as a medium-sized commercial synthesizer — at a considerably lower cost.

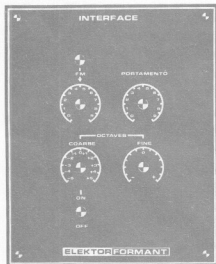

The availability of printed circuit boards and front panels make it a true home construction project for the reasonably skilled and sufficiently enthusiastic amateur. The module system pioneered by R.A. Moog is used — the unit consists of 8 basic modules that can be plugged into printed circuit board connectors. More than one of each module can be used in one instrument, of course.

The complete project will be described in a series of seven articles, starting next month. The first part is a fairly extensive introduction into the subject of

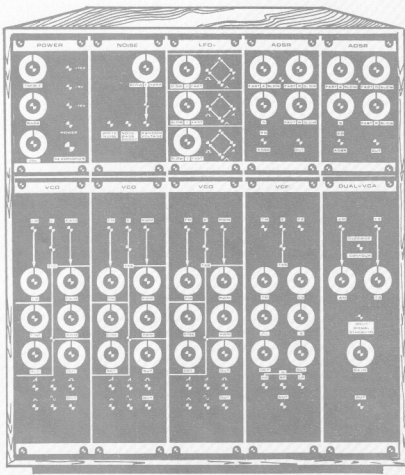

9722 12

music synthesizers; the rest of the series explains the electronics and the mechanical construction of the Formant. If all goes according to schedule (and we

don't see why it shouldn't!) the last instalment should be published in January 1978 . . .

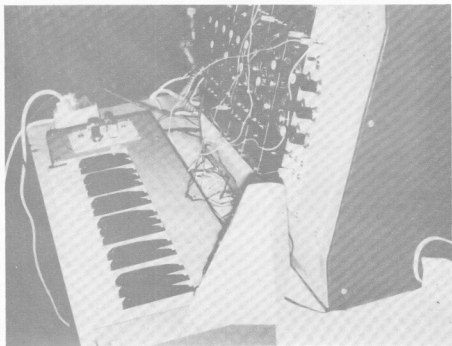

slotless model car track

(1)

Model car race tracks have been popular for many years. However, all of the commercially available tracks have the disadvantage that the car is guided by a pin which engages in the slotted track, and the 'driver' controls only the speed of the vehicle. In the Elektor race track the cars are freed from this restraint and both speed and steering are remotely controlled using an infra-red link. The proportional control system used can easily be extended and used in a radio control system for other models, as will be described in a future article.

Infra-red links are now becoming well known in applications such as cordless headphones for audio use, and figure 1 shows the Siemens BPW34 photodiode and LD241 infra-red LED used in these devices (and in the car race track!). Infra-red radiation is ideally suited to short range links where the photodiode is always within 'sight' of the infra-red emitter. In the Elektor race track the infra-red LEDs are mounted on a column in the centre of the race track, while the photodiodes are mounted on the roofs of the cars. One advantage of using an infra-red link is that no Post Office licence is required.

The Track

It would be nice to make the car completely independent of the track by having it battery powered, but unfortunately the small size of model race cars precludes this. It is not possible to

mount large enough batteries to give the required speed and range, plus all the control electronics, inside the car. Instead, the car picks up its power from a special track by an ingenious contact arrangement. The underside of a car with steering servo is shown in figure 2, while figure 3 shows the track layout and details of the contact arrangement.

The track consists of parallel metallic strips alternately connected to positive and negative supply rail. The contacts on the car are arranged at the apices of an equilateral triangle with a fourth contact at the centre. This arrangement ensures that at least one contact is always touching a positive strip and at least one is always touching a negative strip, whatever the position of the car. Eight diodes, shown in figure 4, 'decode' the voltage so that the same polarity always appears at the + and - output

terminals, independent of the car position or the direction in which it is facing.

The track can be made by glueing aluminium foil to a baseboard using contact adhesive. When the adhesive is set the track pattern can be scored in the foil using two modelling knife blades with a 5 mm spacer between them. The unwanted sections of foil can then simply be peeled off. For straight runs a metal straightedge should be used to guide the blades. Even in bends it is advisable to keep the gaps between the tracks running in parallel straight lines. This implies that if the gaps run lengthwise along one straight, they will be at right-angles to the track after the curve.

If required the track can be made up in several sections to facilitate storage. To make electrical connection between the various sections each section can be equipped with a miniature two pin

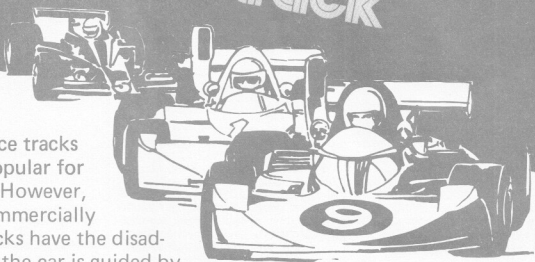

6

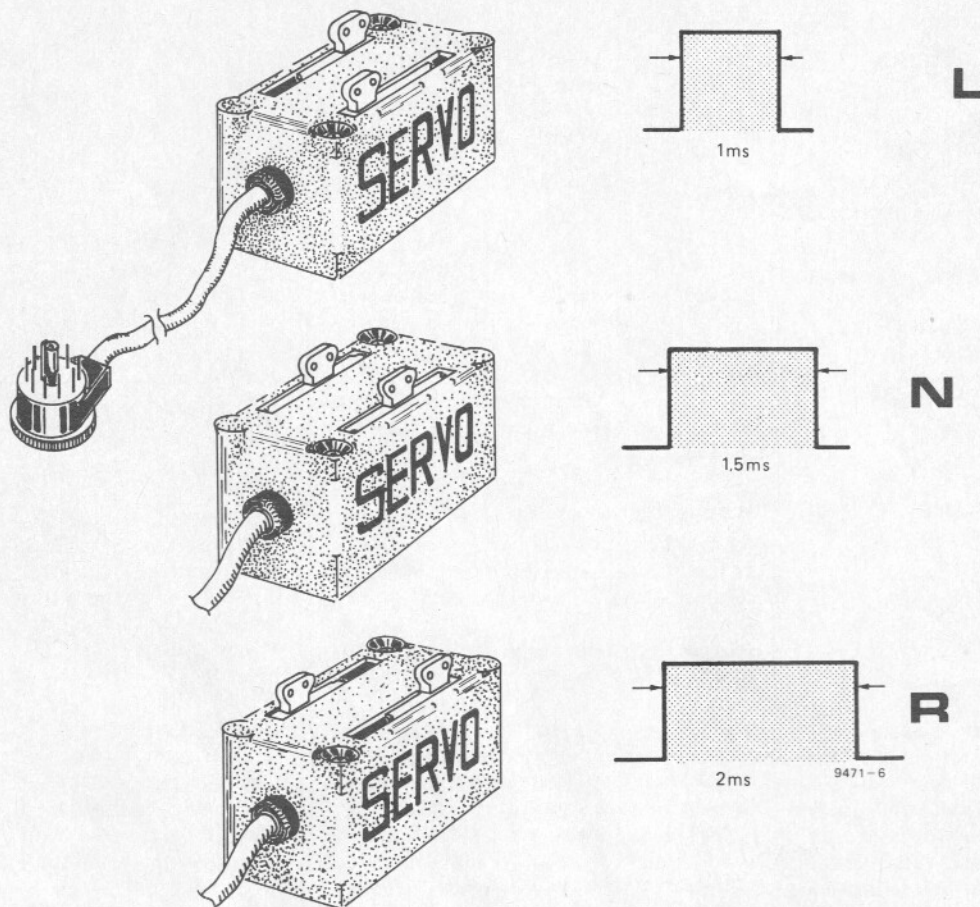

at points A and B or A' and B' and inserting a milliammeter. The current should be set to 180 mA maximum. Figure 7b shows two arrays of infra-red LEDs mounted in a reflector housing to direct the radiation down onto the track.

Infra-red Receiver

Figure 8 shows the circuit of the infra-red receiver. This is extremely simple and compact. The receiving element is a BPW34 infra-red photodiode. The leakage current of this diode varies with the

infra-red radiation falling upon it. A resonant circuit consisting of L1, C1 and C2 is tuned to the operating frequency of the transmitter and rejects any low frequency interference such as 100 Hz pickup from room lighting. Since the leakage current of the BPW34 is small the circuit impedance is fairly high so a source-follower FET T1 is provided as an impedance converter. T2 amplifies the signal to a level suitable for the FM amplifier and demodulator IC1. The demodulated pulse train appears at pin 8 of this IC.

Figure 9 shows a block diagram of the

complete system. Control commands from the joysticks are fed into the multiplex encoder, block 1, and thence to the transmitter, block 2. The received signal is demodulated in the receiver, block 5, and fed to the de-multiplexer, block 6. The decoded pulses from this are fed to the servo and drive motor control amplifiers, blocks 7 and 8. Power for the whole in-car system is derived from the track via the contacts, the diode bridge, block 3, and a stabilised power supply, block 4. The control circuits will be discussed in detail in the following parts of this article.

7a

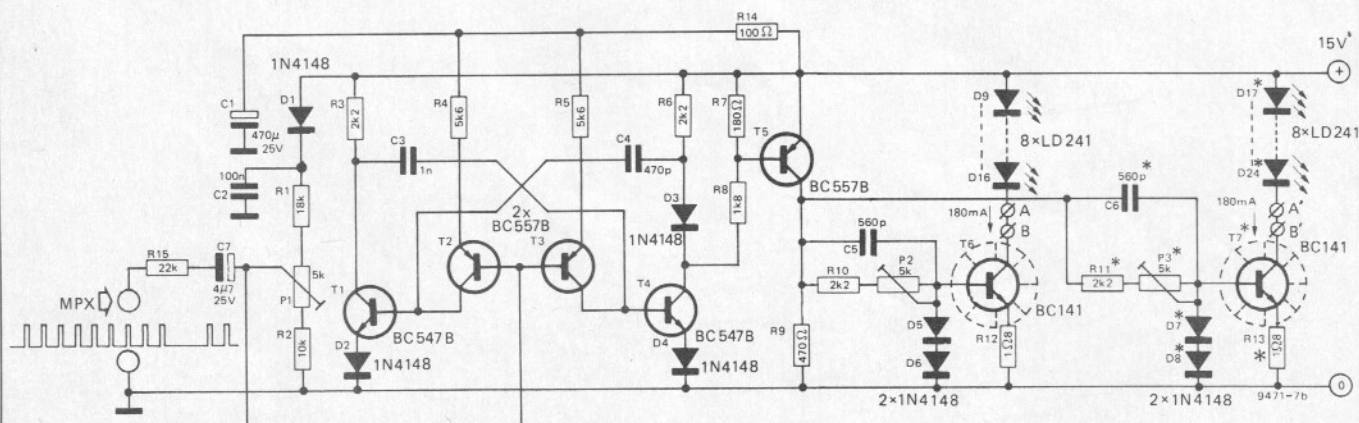

* see text

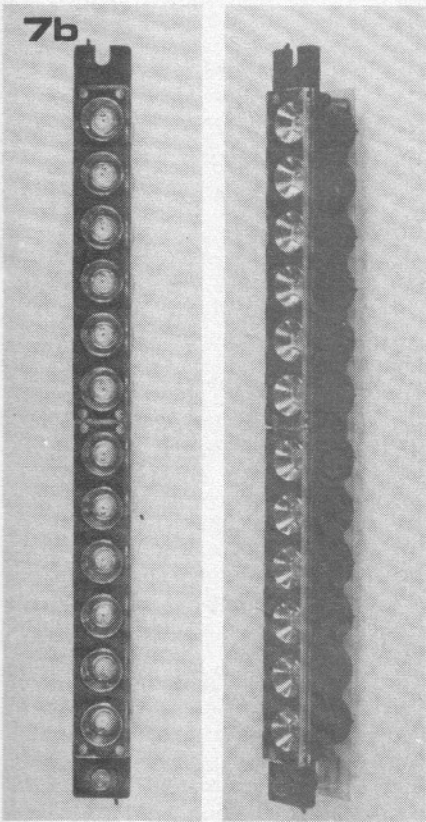

Figure 6. Showing the principle of 'digi-proportional' servo control.

Figure 7a. Circuit of the infra-red transmitter.

Figure 7b. An array of infra-red LEDs mounted in a reflector housing.

Figure 8. Circuit of the infra-red receiver.

Figure 9. Block diagram of the complete infra-red control system.

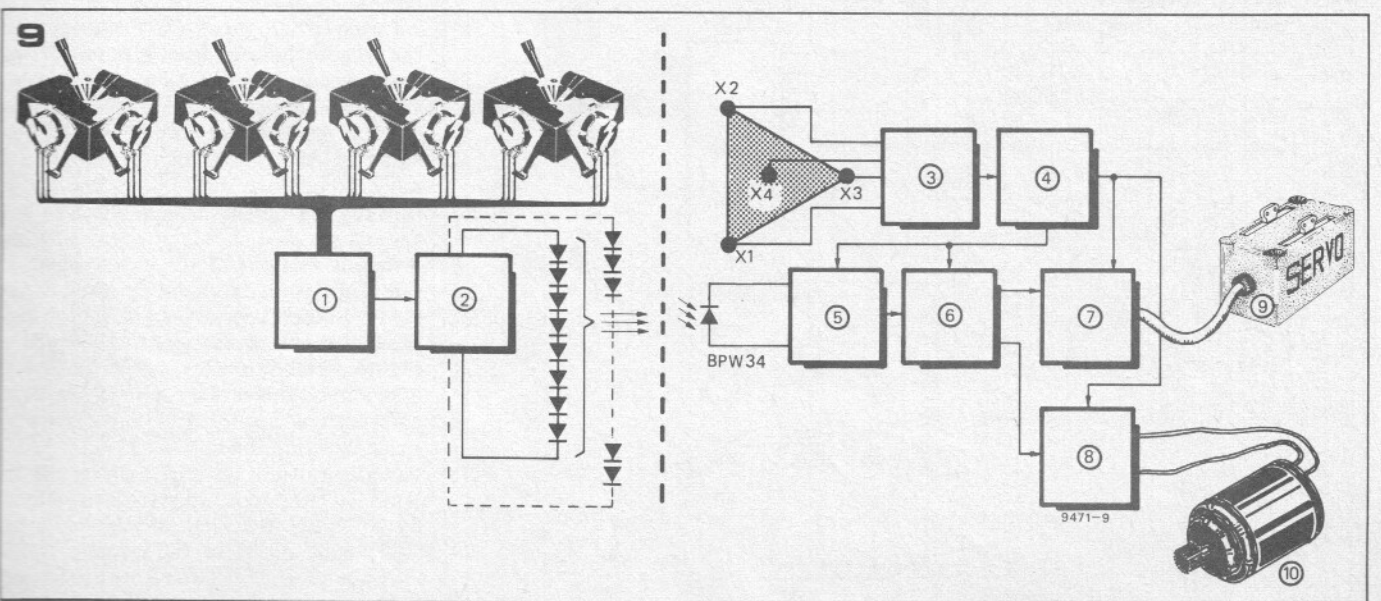
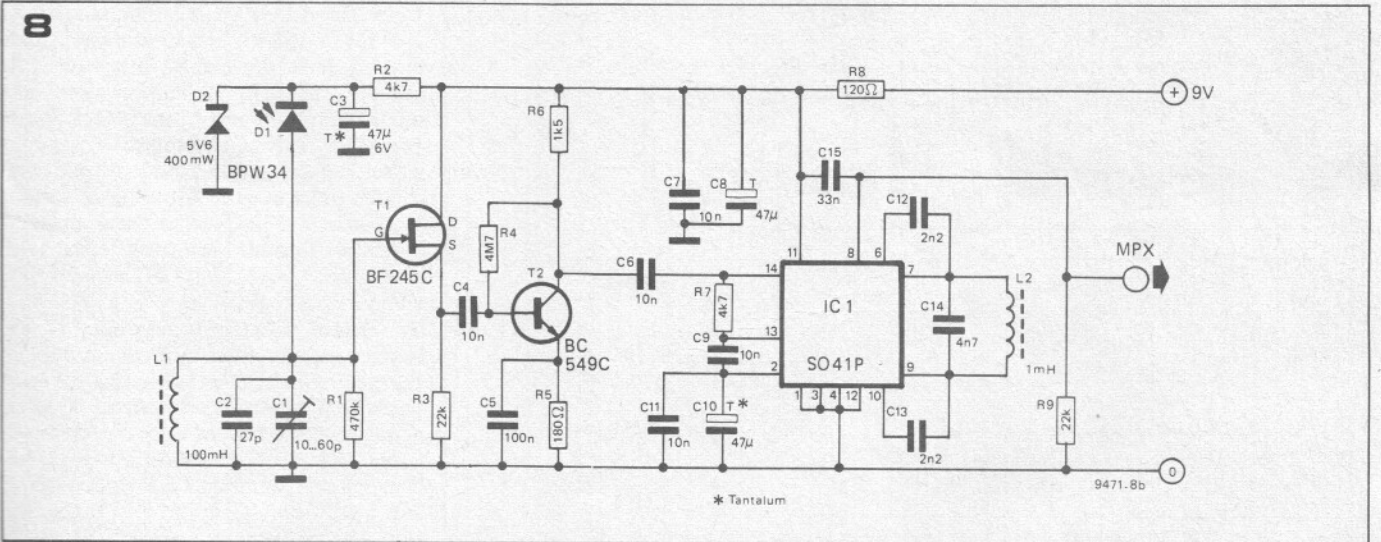
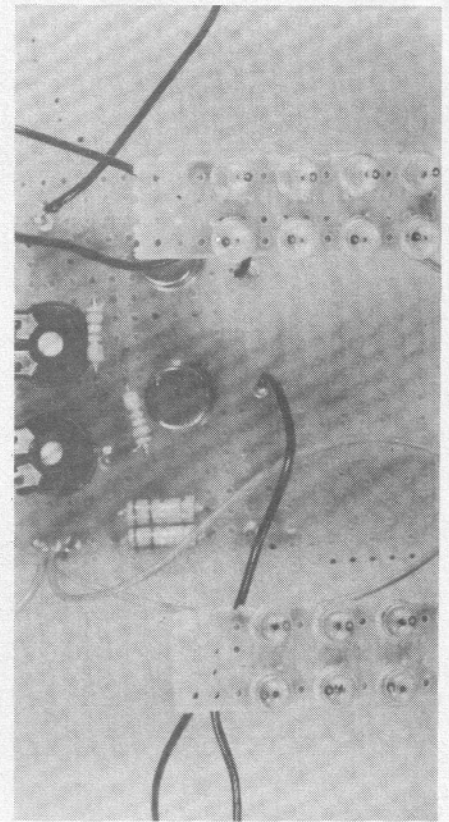

morse decoder with ddll (2)

E.H. Leefsma

The first part of this article dealt with the general operating principles of the morse decoder. In this part the complete circuit is considered in detail, together with some methods of displaying the decoded message.

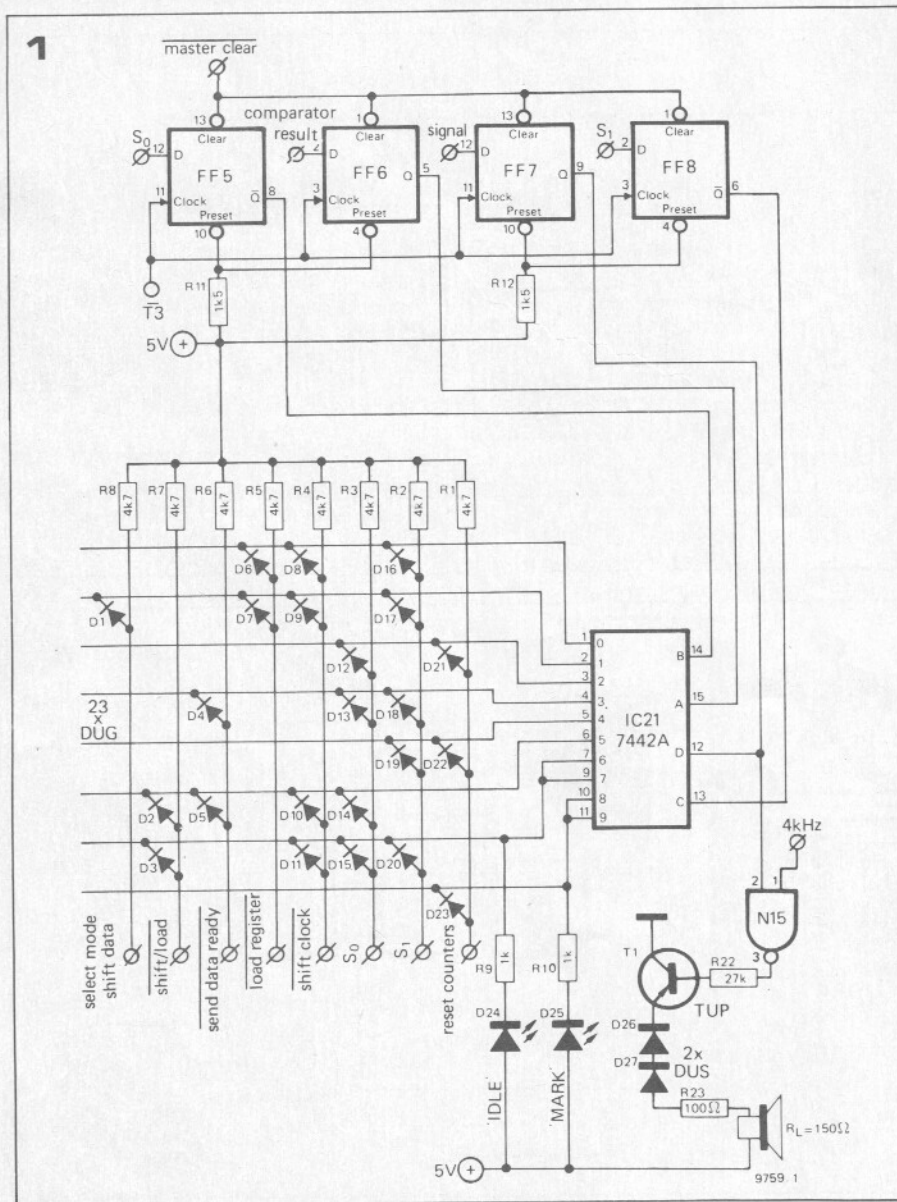

At the end of last month's discussion the general principles of the decoder had been established, terminating with a description of the operating sequence on receipt of a morse message, which is controlled by the status register and decoder.

Practical circuit

Figure 1 shows the circuit diagram of the status decoder. The register proper consists of four D-flipflops (FF5...FF8), in which S_0 , comparator result, signal level, and S_1 are stored (S_0 and S_1 are the 'previous status' bits). The outputs of the flipflops are connected to a decimal decoder which supplies the eight drive signals via a diode matrix. Some outputs are active low, i.e. when the output is '0', hence there is no 'bar' over these functions. The matrix diodes must be of the germanium type because the threshold voltage of silicon types is too high reliably to pull down a TTL input to a '0' level.

The IDLE-LED lights up when the decoder is idle (status condition A), and the MARK-LED lights up when the level of the input signal is '1'. The small loudspeaker is driven by gated bursts of clock signal and makes the input signal audible in the form of an audio tone. The drive signals obtained are used for the dot/dash/space duration logic and to feed the results into the shift register. Because all this cannot take place simultaneously, the clock pulse generator, as mentioned earlier, is four phase (see fig. 2) and each output gives a clock pulse in turn. When the apparatus is switched on a 'master clear pulse' is given, so that all important initial logic states are fixed and the decoder will always start from the idle position. To ensure reliable functioning of the morse decoder, the input signal applied to the input of the status register must be free from interference. This is achieved by means of the suppressor circuit in the morse decoder (see figure 3). This circuit consists of a shift register and a flipflop (IC10 and FF7); the flipflop (FF7) forming part of the status register.

At each clock pulse (T3) the level of the (digital!) input signal is moved along the shift register. The outputs of this shift register (pins 12...15) and the original input signal are fed to a binary adder (IC22) which in turn stores the most often occurring level in the status flipflop. Its output is connected to the adder, so that in fact there are six different versions of the input signal. If the majority of them are '1', the output is '1'; if there are as many '0's as '1's, the (status) result remains unchanged.

Figure 4 shows the complete circuit diagram of the morse decoder. A large part of it is occupied by the dot/dash/space duration logic.

The x2 multiplication of counter I indicated in the block diagram is obtained by applying the bits of this counter (IC19 and IC20) to the selector input (IC15 and IC16) shifted one position further. The x2/3 multiplication is

Table 1

		Q8	Q7	Q6	Q5	Q4	Q3	Q2	Q1
..-	A	1	1	1	1	1	0	1	0
....	B	1	1	1	0	0	1	1	1
---	C	1	1	1	0	0	1	0	1
---	D	1	1	1	1	0	0	1	1
...	E	1	1	1	1	1	1	0	1
...	F	1	1	1	0	1	1	0	1
---	G	1	1	1	1	0	0	0	1
....	H	1	1	1	0	1	1	1	1
...	I	1	1	1	1	1	0	1	1
---	J	1	1	1	0	1	0	0	0
---	K	1	1	1	1	0	0	1	0
....	L	1	1	1	0	1	0	1	1
...	M	1	1	1	1	1	0	0	0
---	N	1	1	1	1	1	0	0	1
---	O	1	1	1	1	0	0	0	0
---	P	1	1	1	0	1	0	0	1
---	Q	1	1	1	0	0	0	1	0
---	R	1	1	1	1	0	1	0	1
...	S	1	1	1	1	0	1	1	1
---	T	1	1	1	1	1	1	0	0
...	U	1	1	1	1	0	1	1	0
---	V	1	1	1	0	1	1	1	0
---	W	1	1	1	1	0	1	0	0
---	X	1	1	1	0	0	1	1	0
---	Y	1	1	1	0	0	1	0	0
---	Z	1	1	1	0	0	0	1	1
---	1	1	1	0	1	0	0	0	0
...	2	1	1	0	1	1	1	0	0
---	3	1	1	0	1	1	1	0	0
...	4	1	1	0	1	1	1	1	0
...	5	1	1	0	1	1	1	1	1
...	6	1	1	0	0	1	1	1	1
---	7	1	1	0	0	0	1	1	1
---	8	1	1	0	0	0	0	1	1
---	9	1	1	0	0	0	0	0	1
---	0	1	1	0	0	0	0	0	0
---	.	1	0	1	0	1	0	1	0
---	,	1	0	0	0	1	1	0	0
---	?	1	0	1	1	0	0	1	1
---	[1	1	0	0	1	0	1	0
---]	1	1	0	1	0	1	0	1

Table 2

	a	b	c	d	e	f	g
A	1	1	1	1	1	0	1
B	0	0	1	1	1	1	1
C	0	0	0	1	1	0	1
D	0	1	1	1	1	0	1
E	1	0	0	1	1	1	1
F	1	0	0	0	1	1	1
G	1	0	1	1	1	1	0
H	0	0	1	0	1	1	1
I	1	0	1	0	0	0	0
J	1	0	1	1	0	0	0
K	1	0	1	0	1	1	1
L	0	0	0	1	1	1	0
M	1	1	1	0	1	1	0
N	0	0	1	0	1	0	1
O	0	0	1	1	1	0	1
P	1	1	0	0	1	1	1
Q	1	1	1	0	0	1	1
R	0	0	0	0	1	0	1
S	1	0	1	1	0	1	1
T	0	0	0	1	1	1	1
U	0	0	1	1	1	1	0
V	0	1	1	1	1	1	0
W	0	1	1	1	1	1	1
X	0	1	1	0	1	1	1
Y	0	1	1	1	0	1	1
Z	1	1	0	1	1	0	1
1	0	1	1	0	0	0	0
2	1	1	0	1	1	0	1
3	1	1	1	1	0	0	1
4	0	1	1	0	0	1	1
5	1	0	1	1	0	1	1
6	1	0	1	1	1	1	1
7	1	1	1	0	0	0	0
8	1	1	1	1	1	1	1
9	1	1	1	1	0	1	1
0	1	1	1	1	1	1	0
.	0	0	0	1	0	0	0
,	0	0	1	0	0	0	0
?	1	1	0	0	1	1	0
[1	0	0	1	1	1	0
]	1	1	1	1	0	0	0

Figure 1. Practical circuit of the status decoder. The diodes used for the matrix are germanium types because they have a low threshold voltage.

Figure 2. Circuit diagram of the clock-pulse generator. An external oscillator may also be used, so the morse decoder can be adapted to extremely low or extremely high signalling speeds.

Figure 3. Diagram of the signal processor. In principle six 'samples' are taken of the input signal, after which the most occurring 'level' is decisive.

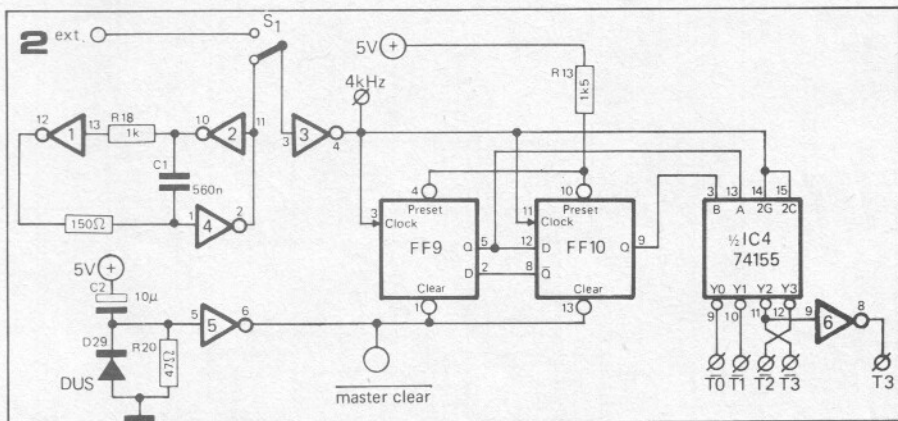
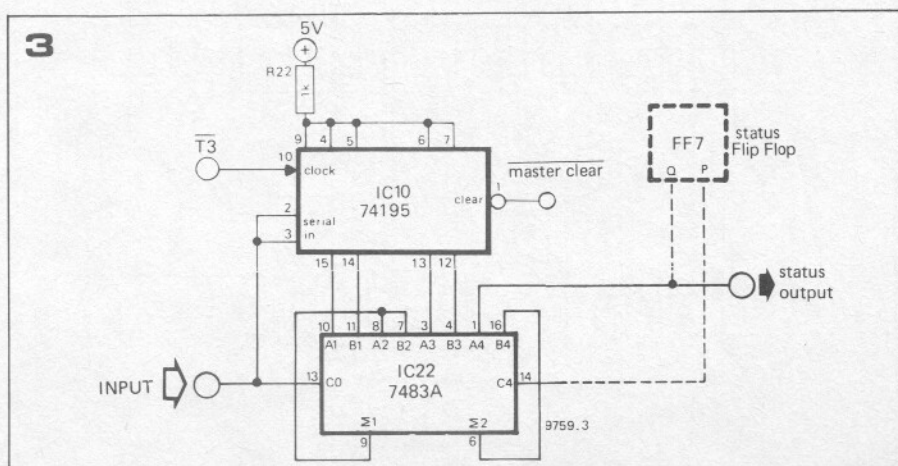
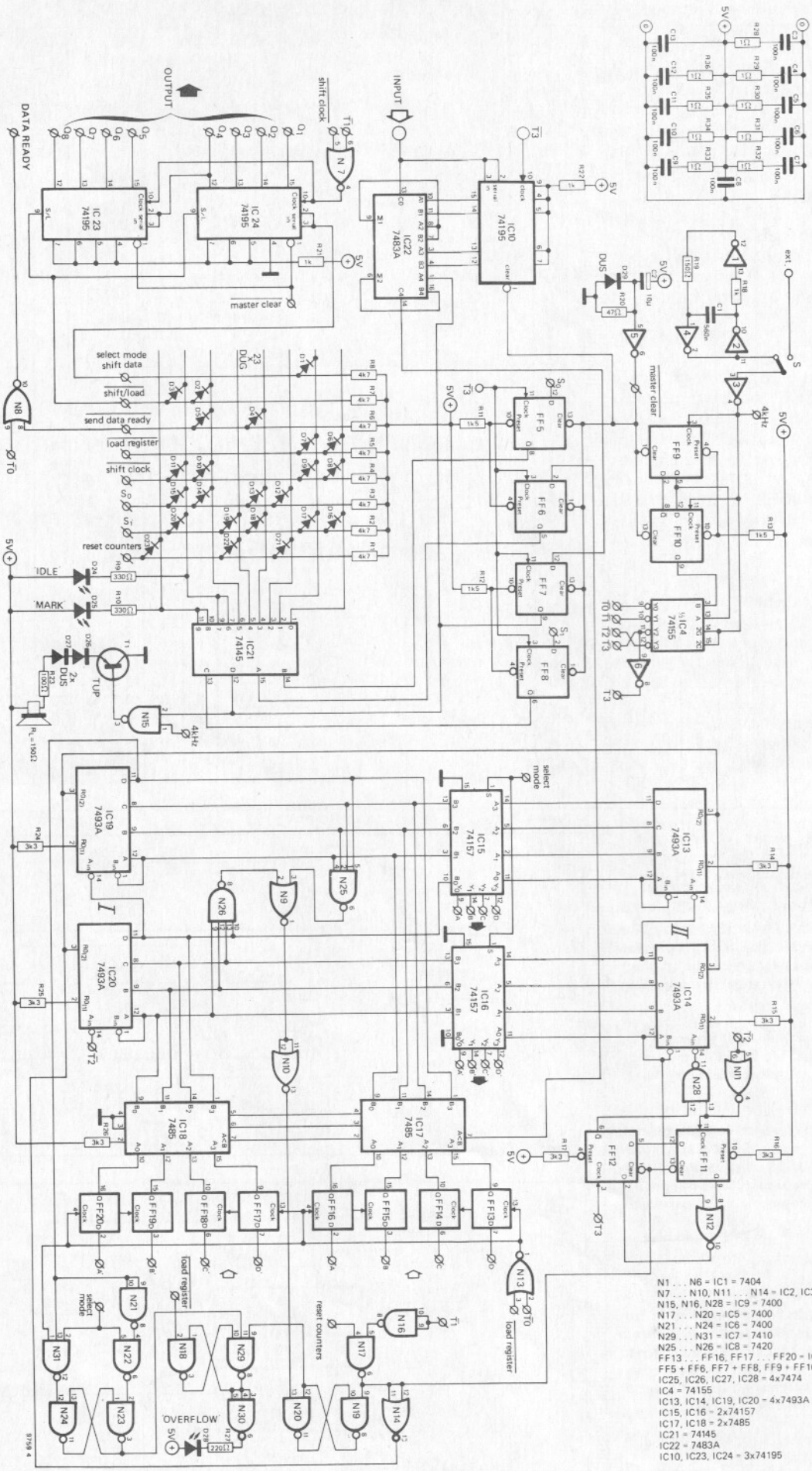

Table 1. Showing the morse decoder output codes for letters, digits and punctuation marks. This table may be used to programme the character decoder (upper half of figure 8). Each transistor corresponds to a particular character, and to turn a transistor on all the Q outputs which are '1' must be connected to its base by diodes together with all the Q outputs which are '1'.

Table 2. Showing which segments are lit for a particular character. This table may be used to programme the display decoder (lower half of figure 8). The emitter of the appropriate transistor is connected via a diode to each segment-line whose logic state is '1'.





- N1 ... N6 = IC1 = 7404
- N7 ... N10, N11 ... N14 = IC2, IC3 = 2x7402
- N15, N16, N28 = IC9 = 7400
- N17 ... N20 = IC5 = 7400
- N21 ... N24 = IC8 = 7400
- N25 ... N31 = IC7 = 7410
- N32 ... N26 = IC8 = 7420
- FF13 ... FF16, FF17 ... FF20 = IC11, IC12 = 2x7475
- FF5 + FF6, FF7 + FF8, FF9 + FF10, FF11 + FF12 = IC25, IC26, IC27, IC28 = 4x7474
- IC4 = 74155
- IC13, IC14, IC19, IC20 = 4x7493A
- IC15, IC16 = 2x74157
- IC17, IC18 = 2x7485
- IC21 = 74145
- IC22 = 7483A
- IC10, IC23, IC24 = 3x74195

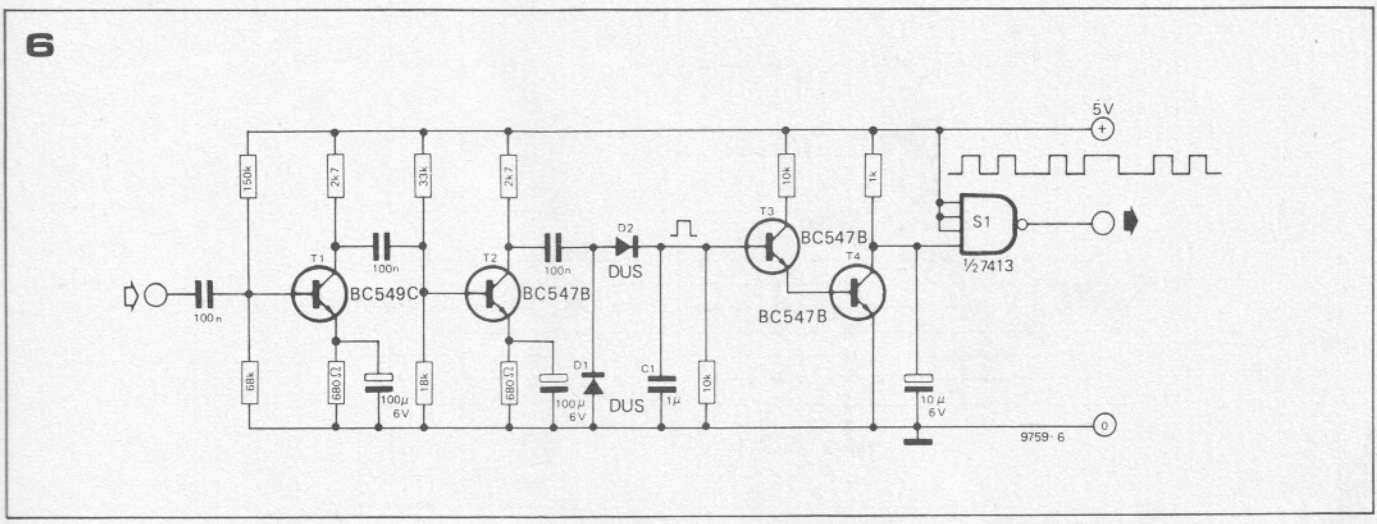
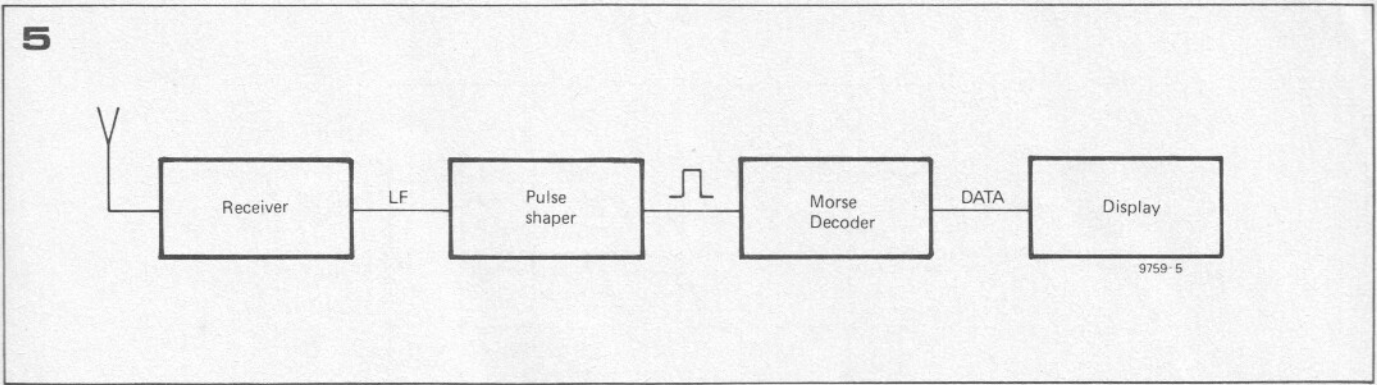
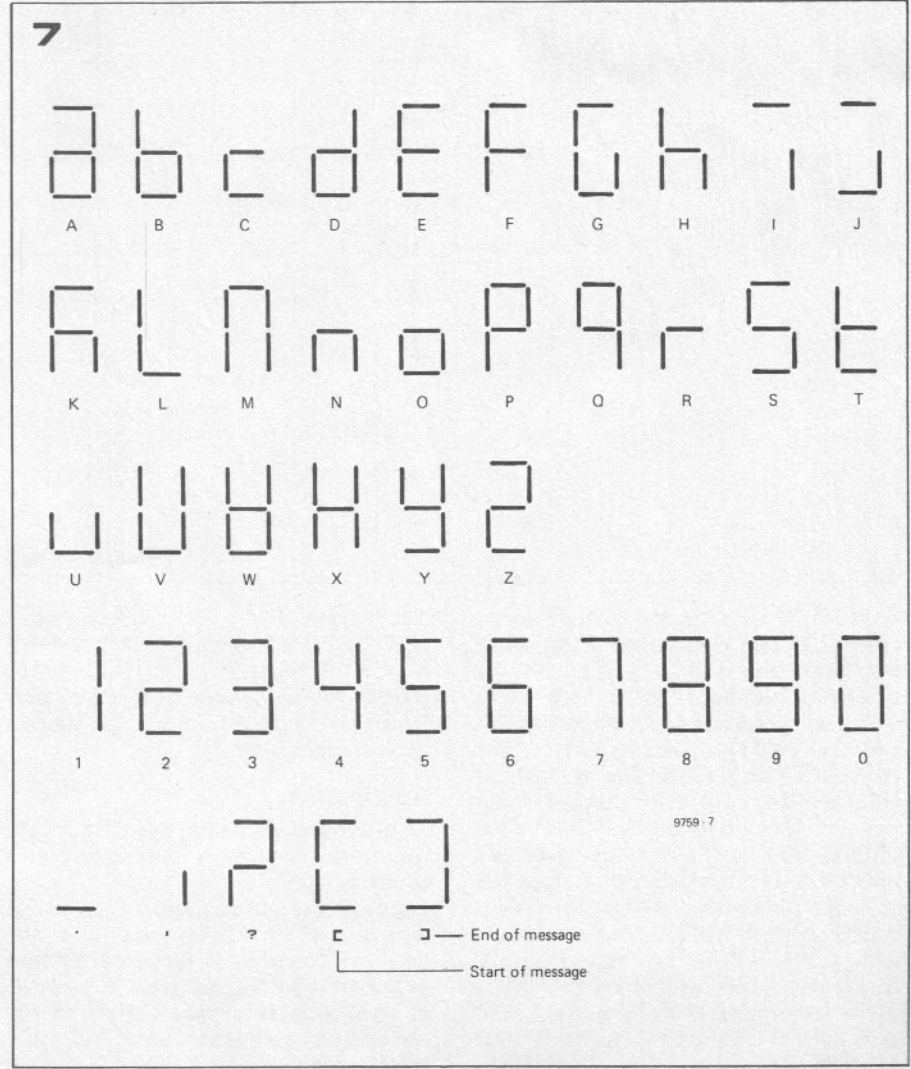

Figure 4. Complete circuit of the morse decoder. The circuit uses 28 TTL ICs.

Figure 5. Example of a receiving chain of which the morse decoder forms part.

Figure 6. This circuit can be used to convert the tones received into pulses.

Figure 7. Modified alphabet for use with seven-segment displays. The text becomes quite legible after some practice.



8

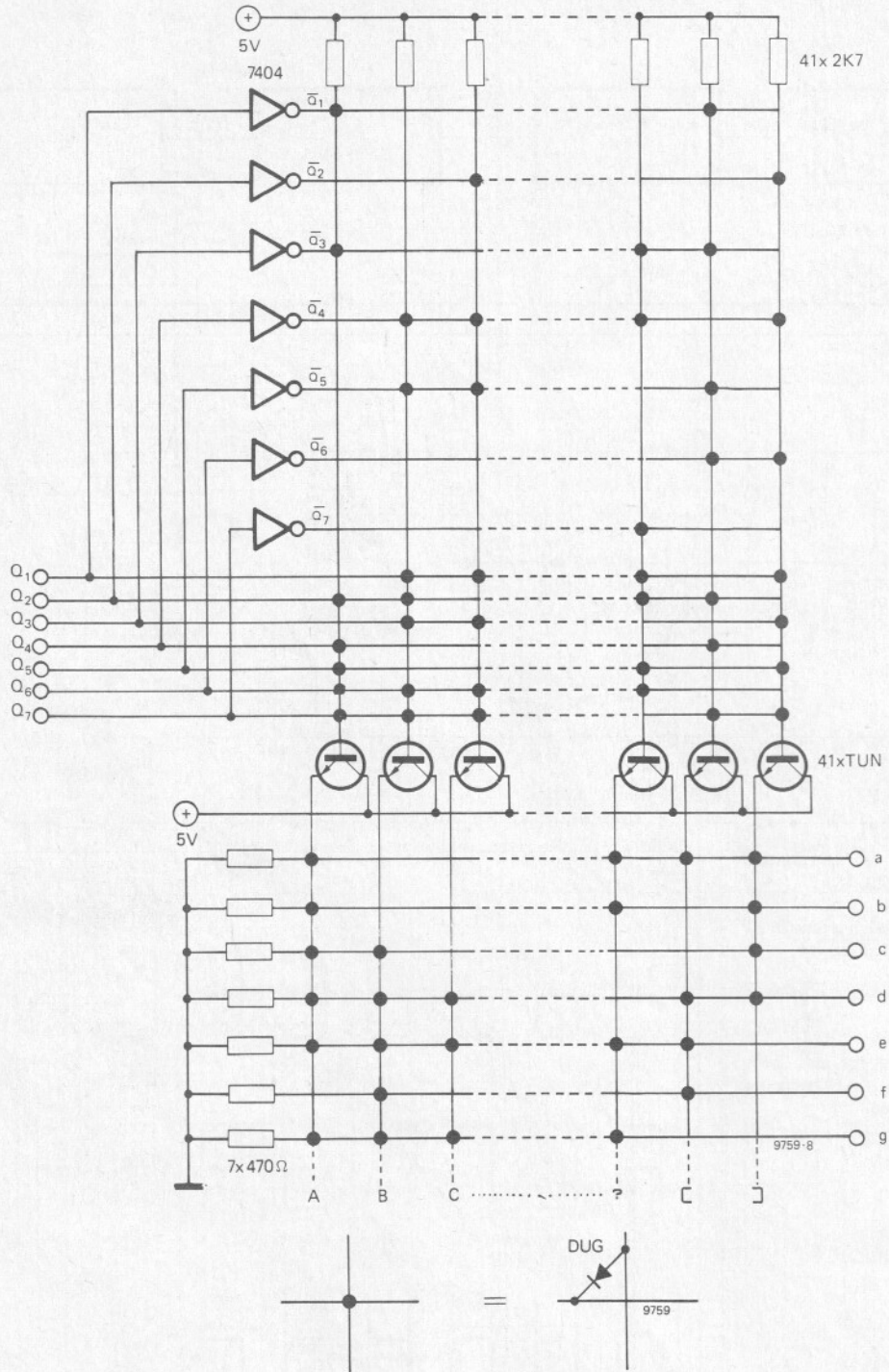

achieved by blocking the count input of counter II one clock period after each two clock pulses (T2). This is done by means of flipflops FF11 and FF12 which are connected as a divide-by-two counter. Other important parts of the morse decoder are the gates N17...N24, N29...N31. It may happen that counter I (in one of the stable conditions B, C, or D) counts over the maximum counter reading or that the 'number' to be loaded into the register does not 'fit in'. In either case decoding is no longer reliable, and the gates then ensure that the 'overflow-LED' lights up as a warning that signalling is too slow or that a continuous signal (CW) is received.

The output of the decoder consists of IC24 and IC23 which together form an 8-bit shift register. At the output the letters received appear in the code which can be transferred at the time of 'data-ready' (Table 2).

Application

As already explained in the first article, the morse decoder is only a link in a receiving chain.

Figure 5 gives an example of a possible receiving chain. After reception the detected 'tones' must be converted into pulses to drive the decoder. The circuit of such a pulse shaper is given in figure 6. This particular circuit will only work reliably if the input signal is

relatively 'clean', and preferably of fairly high frequency (above 1 kHz). There is room for improvement here!

The letter code obtained can be further processed in various ways. One of the methods is a running display using seven-segment displays. Although this is certainly not the most elegant solution, reading is easy after some practice.

Figure 7 shows the format of the 'seven-segment alphabet'; Table 3 indicates which segments light for a given letter. Now the output of the morse decoder must be converted into the seven-segment code. There are 26 letters, 10 digits and 5 punctuation marks. In total 41 characters. The letter code is translated into the seven-segment code

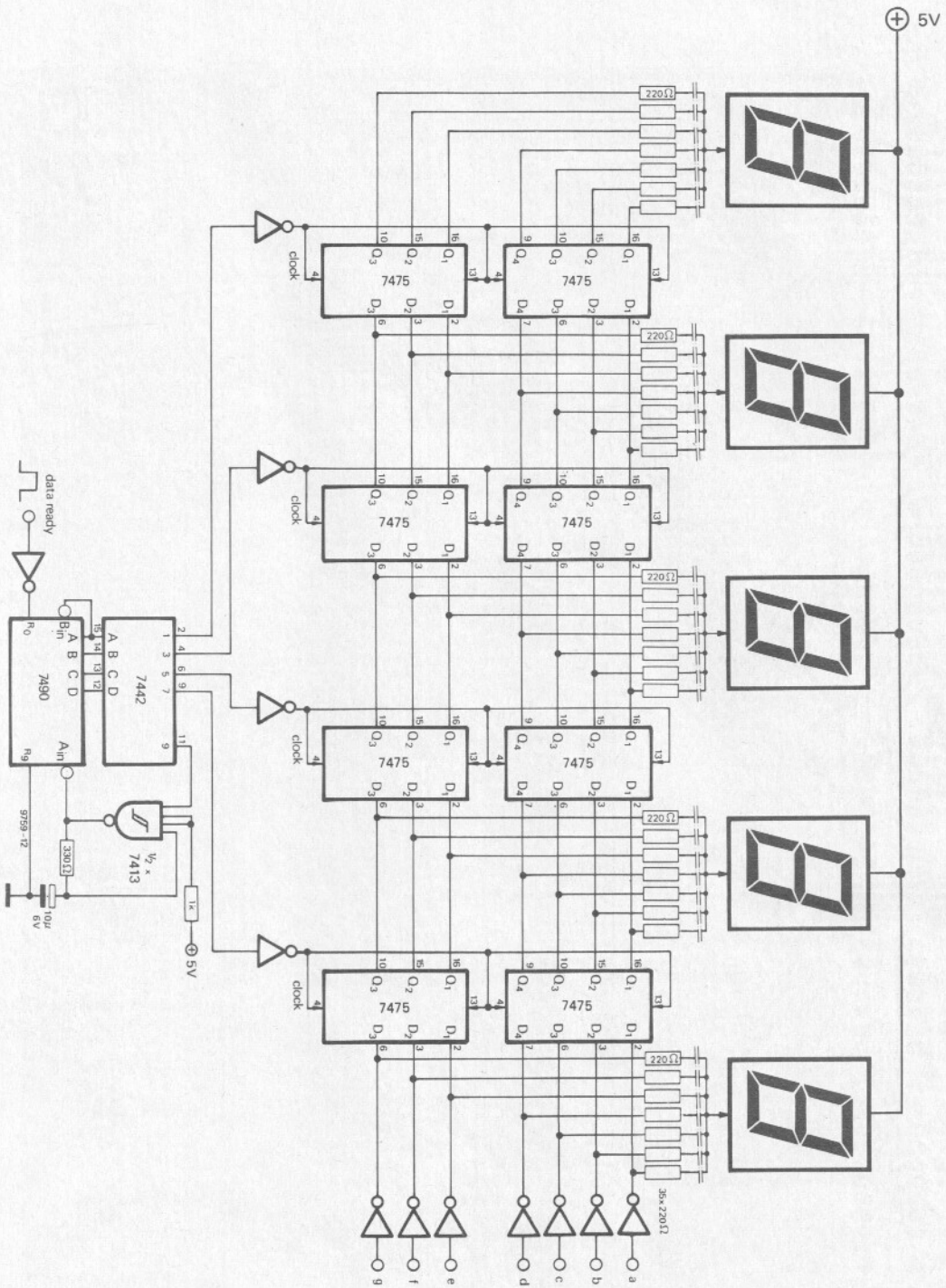

by means of two diode matrices. The first matrix has 7 inputs and 41 outputs, the second has 41 inputs and 7 outputs. Figure 8 shows the converter. Tables 1 and 2 show where the diode connections must be made. For example: If a letter A is read out at the output of the decoder, the output code is as follows:

Q8	Q7	Q6	Q5	Q4	Q3	Q2	Q1
1	1	1	1	1	0	1	0

To turn on the 'A' transistor all 'Q's' which are '1' and all 'Q's' which are '1' are connected to its base via diodes.

The following diode connections are thus made in the first matrix:

Q1	Q2	Q3	Q4	Q5	Q6	Q7
----	----	----	----	----	----	----

Figure 8. Two diode matrices convert the code at the output of the morse decoder into a letter code for the seven-segment displays.

Figure 9. Circuit diagram of a running-script display.

Only if letter A is received, will the base of the first transistor be positive. In the second matrix the connections must now be made which ensure that the right segments of the displays light up; in this case all segments except 'f' (Table 2). On the output of the last matrix the information is now available to drive a display.

In practice a read-out with only one display will not be very intelligible. Therefore figure 9 gives a method of extending the read-out with several displays. The letter received is made visible on the first display, and during the data-ready pulse the data is stored in the first memory, so that the letter appears on the second display. The

10

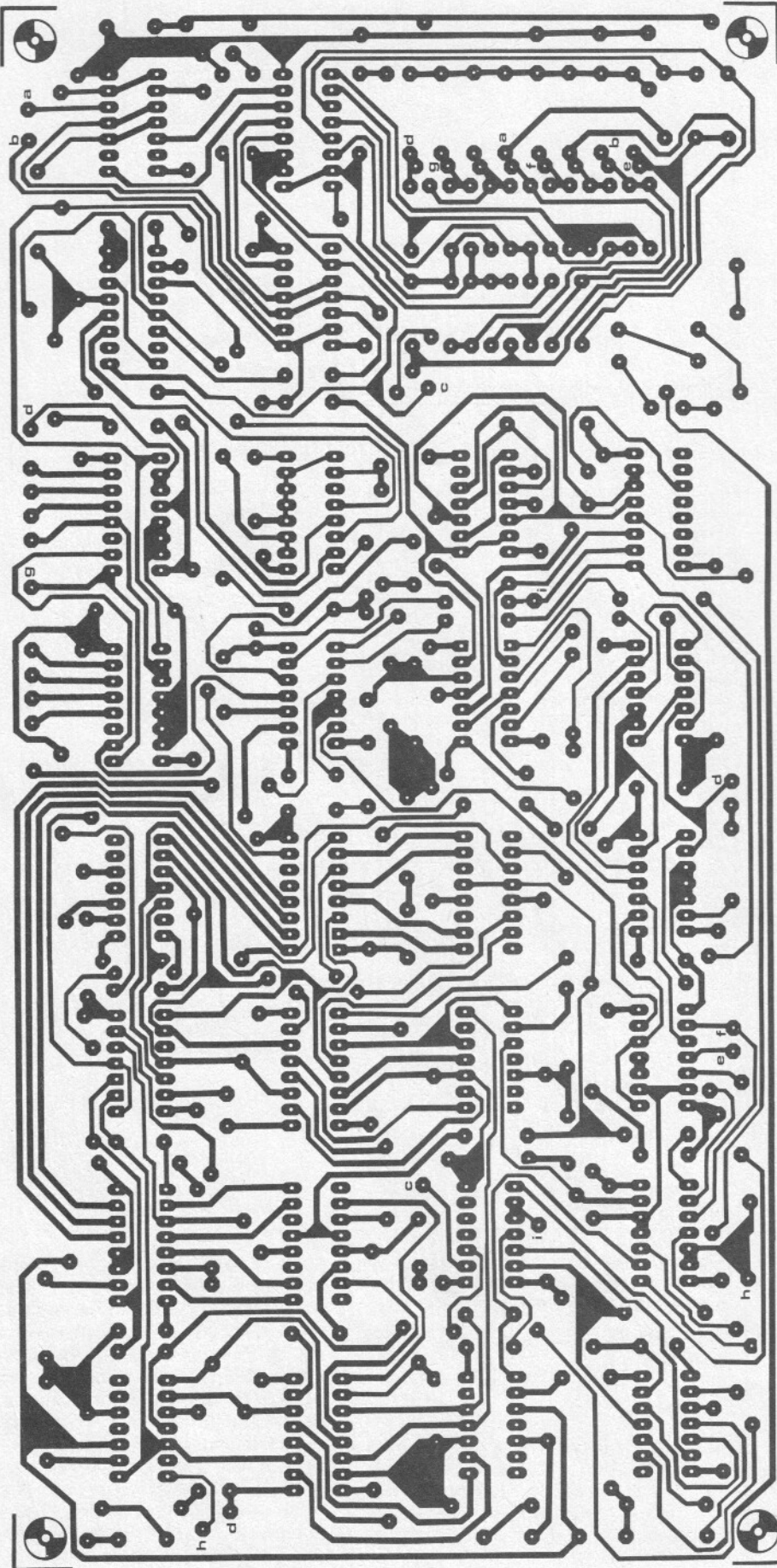

Parts list for
figures 4 and 11.

Resistors:

R1 ... R8 = 4k7
 R9, R10 = 330 Ω
 R11, R12, R13 = 1k5
 R14 ... R17,
 R24 ... R26 = 3k3
 R18, R21, R22 = 1 k
 R19 = 150 Ω
 R20 = 47 Ω
 R23 = 100 Ω
 R27 = 220 Ω
 R28 ... R36 = 1 Ω

Capacitors:

C1 = 560 n
 C2 = 10 μ /6.3 V
 C3 ... C13 = 100 n

Semiconductors:

T1 = TUP
 D1 ... D23 = DUG
 D24, D25, D28 = LED
 D26, D27, D29 = DUS
 IC1 = 7404
 IC2, IC3 = 7402
 IC4 = 74155
 IC5, IC6, IC9 = 7400
 IC7 = 7410
 IC8 = 7420
 IC10, IC23, IC24 = 74195
 IC11, IC12 = 7475
 IC13, IC14,
 IC19, IC20 = 7493A
 IC15, IC16 = 74157
 IC17, IC18 = 7485
 IC21 = 74145
 IC22 = 7483A
 IC25 ... IC28 = 7474

Sundries:

S = Switch SPDT
 R_L = 100 ... 200 Ω loudspeaker

Figures 10 and 11. Component layout and p.c. board for the circuit of figure 4 (EPS 9759). Note, that D19 is not mounted 'the same way round' as its neighbours!

Some wire links are required on the copper side of the board: 'a' is connected to 'a', 'b' to 'b', etc.

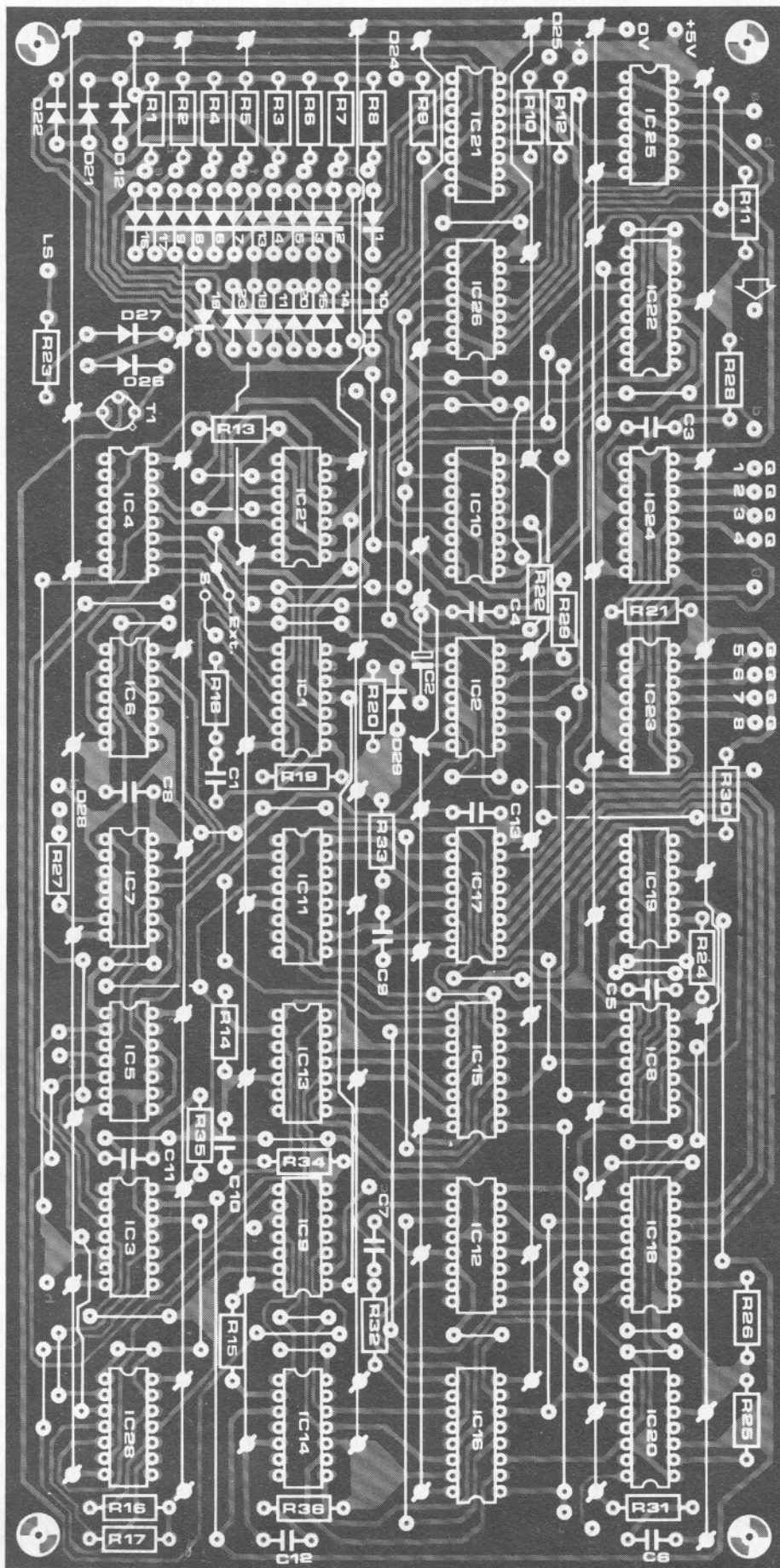

12

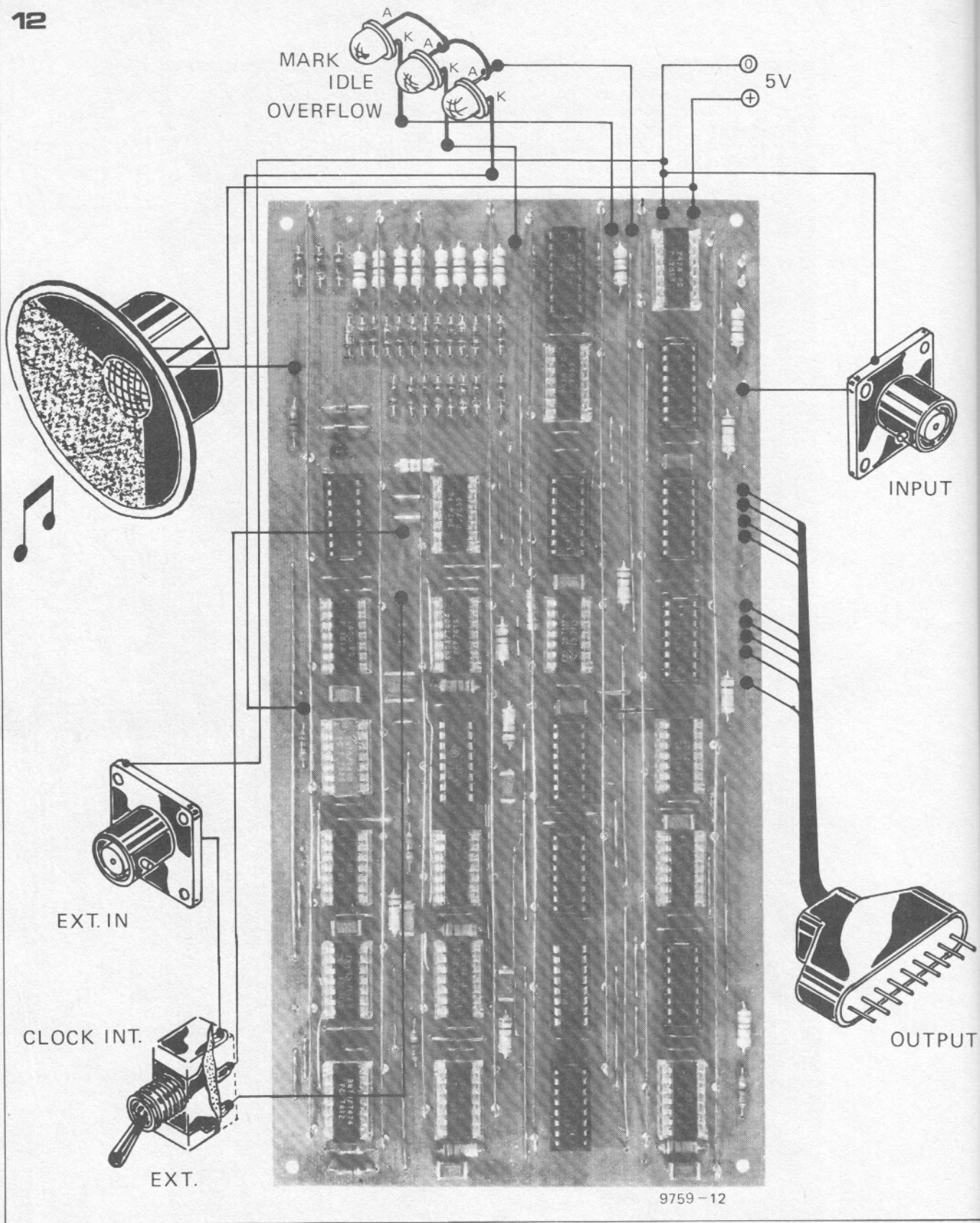

9759-12

Figure 12. External connections to the board.

Figure 13. Suggested power supply. It can be mounted on the TV tennis 5-volt supply board (EPS 9218B).

Table 3. The ASCII code (American Standard Code for Information Interchange).

13

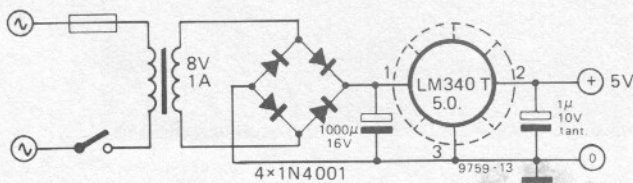

9759-13

Table 3

ASCII CHARACTER CODE

000000	@	100000	BLANK
000001	A	100001	!
000010	B	100010	"
000011	C	100011	#
000100	D	100100	\$
000101	E	100101	%
000110	F	100110	&
000111	G	100111	'
001000	H	101000	(
001001	I	101001)
001010	J	101010	*
001011	K	101011	+
001100	L	101100	COMMA
001101	M	101101	DASH
001110	N	101110	PERIOD
001111	O	101111	/
010000	P	110000	0
010001	Q	110001	1
010010	R	110010	2
010011	S	110011	3
010100	T	110100	4
010101	U	110101	5
010110	V	110110	6
010111	W	110111	7
011000	X	111000	8
011001	Y	111001	9
011010	Z	111010	:
011011	{	111011	;
011100		111100	^
011101	}	111101	~
011110	^	111110	V
011111	UNDERLINE	111111	?

letters are constantly shifted further so that 'running-script' results.

As already said, this form of read-out is intended only as an example. High signalling speeds require a large number of displays to keep the message received legible An alternative solution would be to use a teletype or ASCII display. The latter may be of particular interest, and the code is shown in Table 3. The 'double diode matrix' principle of figure 8 can be used.

Construction

A printed circuit board layout is shown in figures 10 and 11. For reasons of economy, a double-sided board was not used, so a large number of wire links are required. The long links with 'φ' marks at each connection are the supply lines; these are mounted last as 'overhead wires'. It is advisable to use solder posts and interconnect them with insulated wire links.

A further set of (insulated!) wire links is required on the copper side of the board. These interconnect points 'a' and 'a', 'b' and 'b' etc.

As with all TTL circuits, it is advisable to mount the unit in a screened box. The external connections to the board are shown in figure 12.

A suitable power supply is shown in figure 13. The IC should be adequately cooled; the heatsink should have an area of at least 40 cm² (6in.²).

digisplay on board

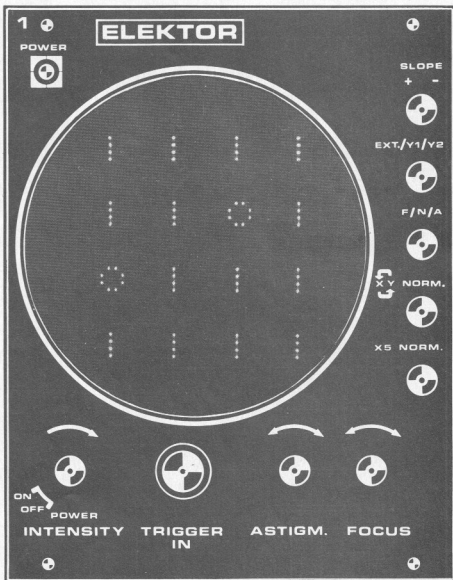

The 'Digisplay' circuit described in E13 (May 1976, p.538) has proved to be more popular than we had expected. Whenever the working model was demonstrated at radio shows we received a large number of requests for a design for a printed circuit board.

A suitable board design is shown in figures 1 and 2. Since the unit will normally be used as a more-or-less self-contained measuring instrument, a

suitable power supply was included on the board. The circuit of this supply is shown in figure 3. The fuse and transformer are not mounted on the board, of course.

Photo 1. This logic tester displays the states of sixteen binary signals (either '0' or '1') simultaneously, in the convenient form of a 4 x 4 matrix on an oscilloscope screen.

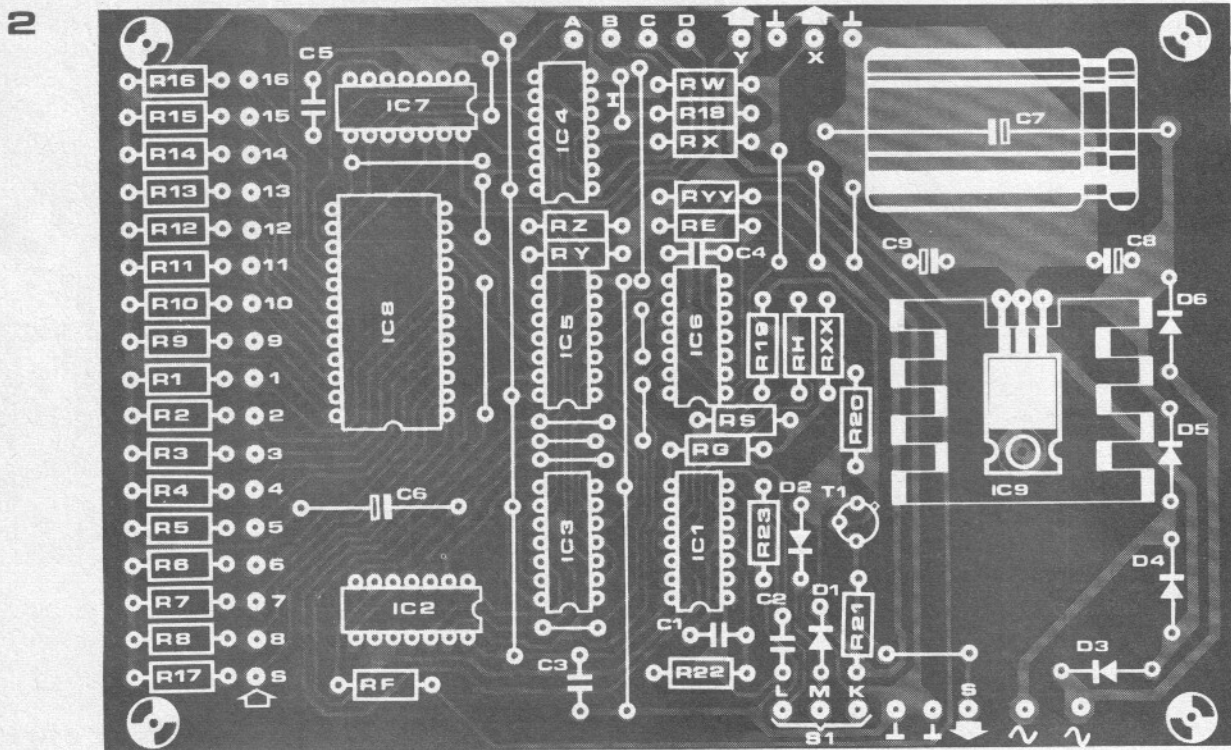
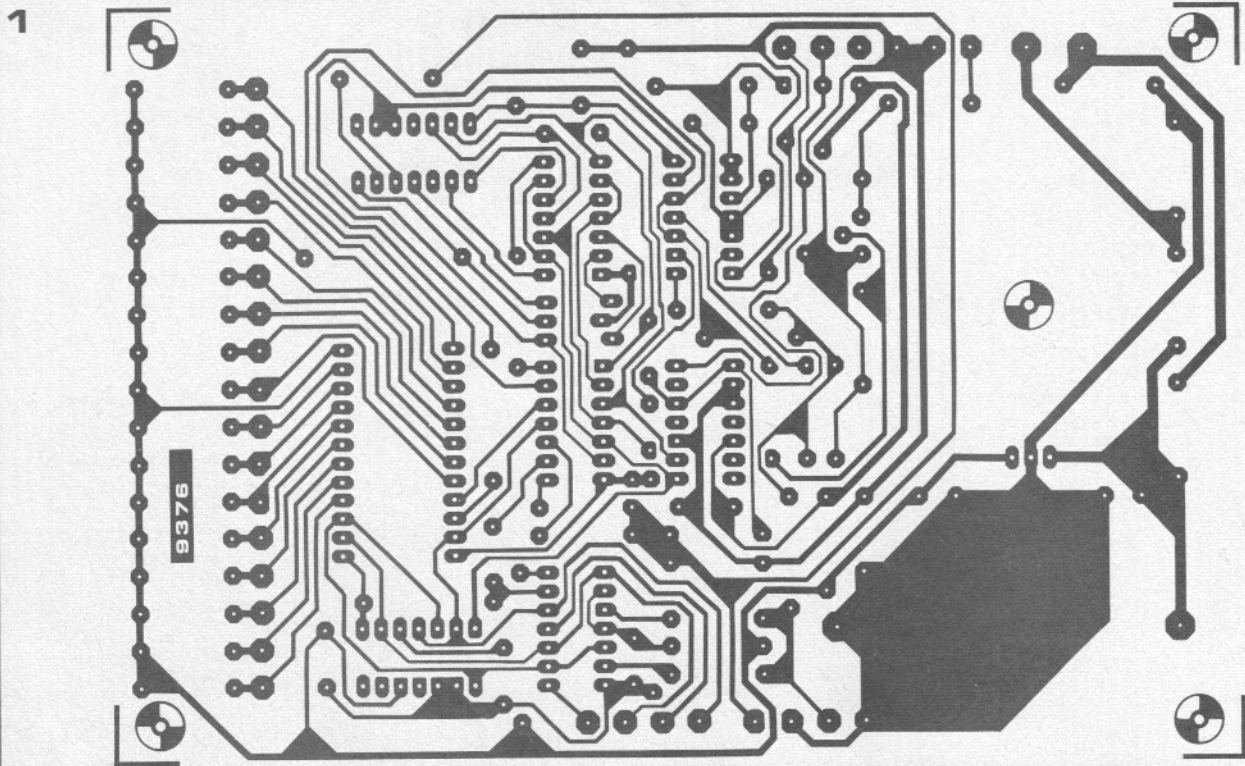

Figure 1. Printed circuit board design for the Digisplay (EPS 9376).

Figure 2. Component layout. Note that there is sufficient space on the board for an adequate heat-sink for IC9.

Figure 3. The power supply circuit.

Figure 4. Complete circuit of the Digisplay, as originally published in May 1976.

Parts list

Resistors:

R1 ... R17, R19, R20 = 10 k
 R18, R_x, R_z = 3k3
 R21 ... R23 = 1 k
 R_{yy}, R_{xx}, R_w, R_y = 6k8
 R_e, R_g = 68 k
 R_f, R_h = 33 k
 R_s = 47 k

Capacitors:

C1, C2 = 33 n
 C3 ... C5 = 10 n
 C6 = 22 μ/6.3 ... 25 V
 C7 = 2200 μ/16 V
 C8, C9 = 10 μ/16 V tantalum

Semiconductors:

T1 = BC547, BC107 or equ.
 D1, D2 = DUS
 D3 ... D6 = 1N4001
 IC1 = 7400
 IC2 = 7420
 IC3 = 7410
 IC4 = 7486
 IC5 = 7404
 IC6, IC7 = 7493
 IC8 = 74150
 IC9 = 7805

Sundries:
 S1 = SPDT (single pole double throw)
 Tr1 = mains transformer, 9 V/300 mA secondary
 Fuse = 100 mA, slow blow.

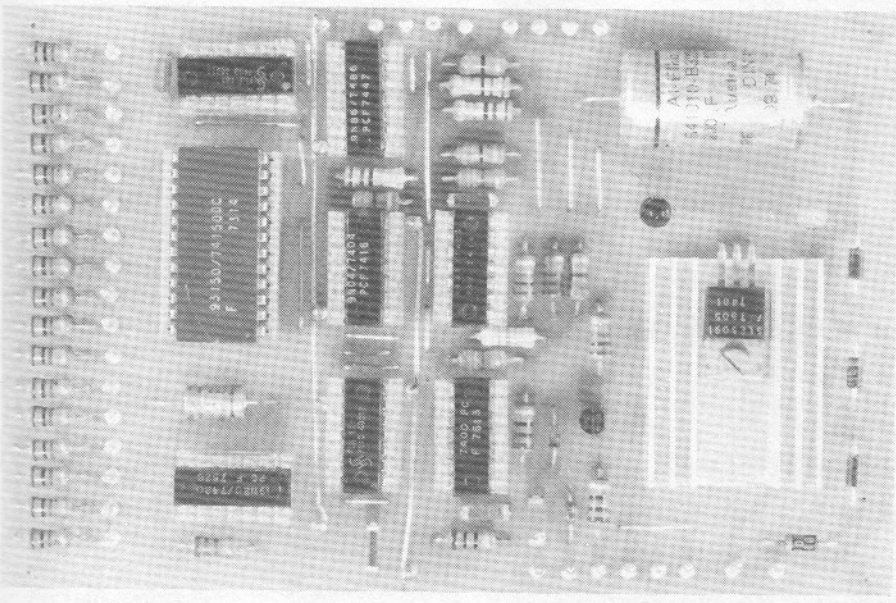
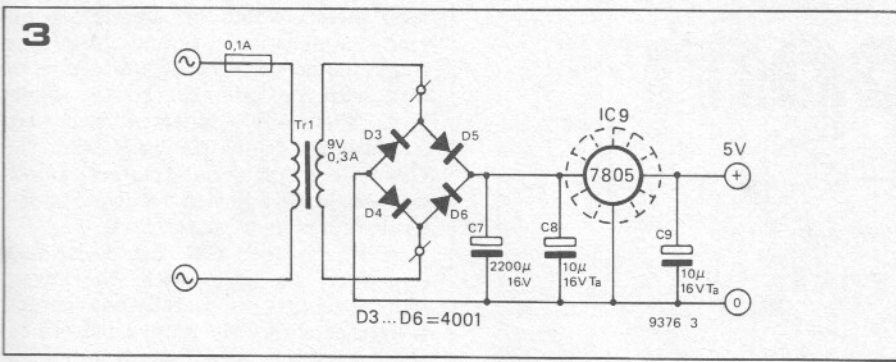

Note that the regulator IC (IC9) should be provided with an adequate heat-sink. There is sufficient room on the board for this.

The complete circuit of the Digisplay is shown in figure 4; however, we will not annoy our regular readers by repeating the article as originally published last May

For our not-so-regular readers, we can sum it up very briefly as follows. The Digisplay tests the states of sixteen binary signals and displays the results on an oscilloscope screen in the particularly convenient form of a four-by-four matrix of '0' and '1' characters. It may be used to test digital integrated circuits; to display logic states in the form of Karnaugh maps; as a programmed 16-bit pulse generator.

A fixed-frequency clock generator is incorporated in the circuit, and an external clock input is also provided. For testing digital ICs and for Karnaugh mapping, the 'X' and 'Y' outputs are connected to the Horizontal (X) and Vertical (Y) inputs of an oscilloscope. The test inputs '1' to '16' are connected to the relevant points in the circuit under test and the unit is switched to the internal clock generator. For Karnaugh mapping, the BCD code corresponding to each position of the display matrix is available at the A, B, C and D outputs. The serial in- and outputs ('S') are required when the unit is used as a programmed pulse generator.

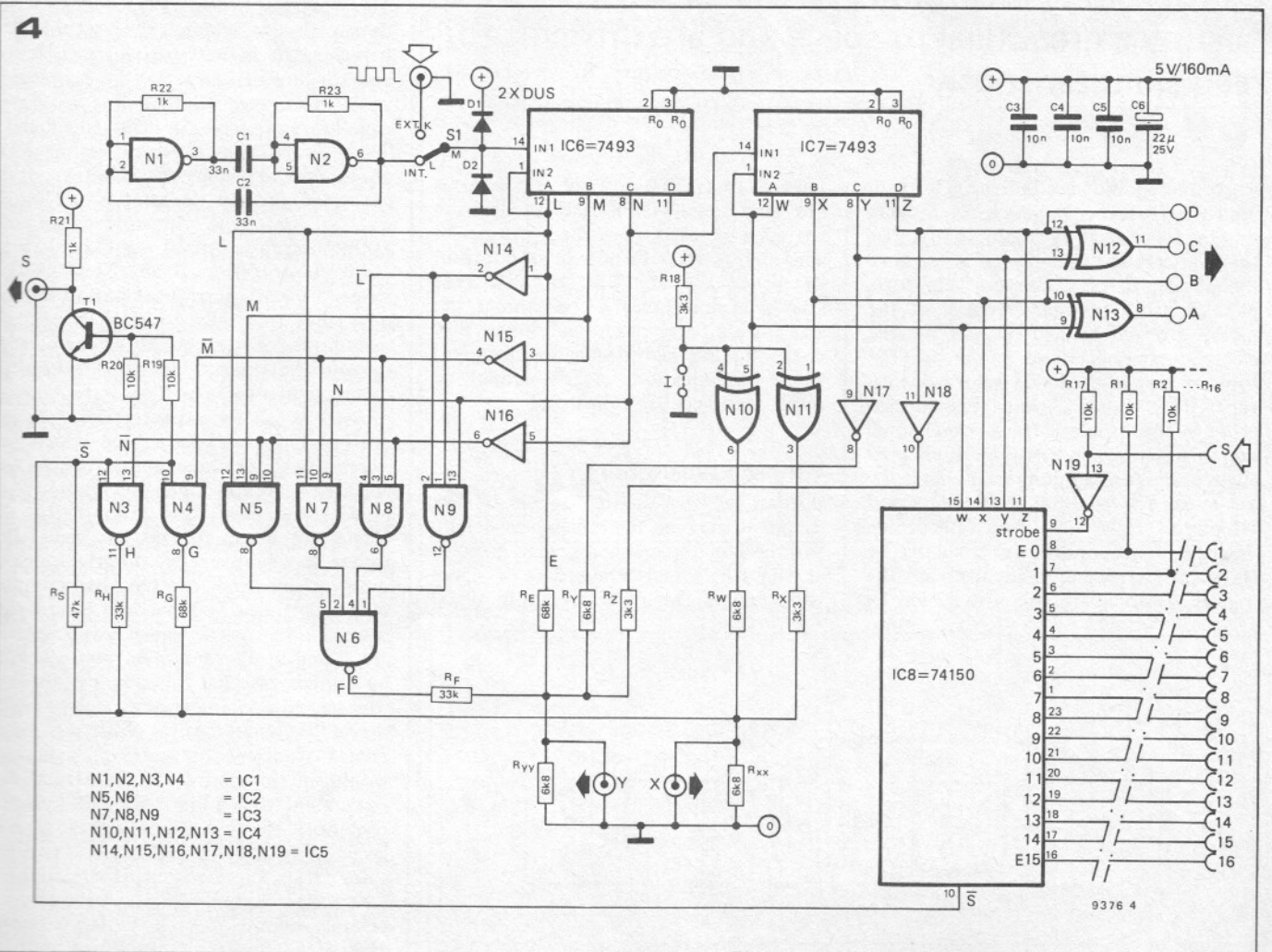

led vu/ppm

VU (Volume Unit) meters and PPMs (Peak Programme Meters) are used widely in the recording industry and by the amateur to monitor audio signal levels. Meters using conventional moving coil indicators have, however, several disadvantages. The ballistics of the meter movement are quite critical, which makes the meters expensive. They are also relatively bulky, which means that in a multichannel recording system the meters occupy a great deal of space and are difficult to read simultaneously.

Recording studios are increasingly turning to instruments in which the moving pointer is replaced by a column of LEDs that indicate the signal level. These have the advantage of occupying very little panel width. The characteristics of the meter are determined purely by the electronic circuitry, so a VU or PPM type of response can be achieved with very little modification. The design given in this article is for a two-channel meter, but this can easily be duplicated to give any desired number of channels. To avoid the possibility of letters and telephone calls from irate recording engineers and enthusiasts, it should be stated at the outset that, although the meters described in this article will be

referred to as 'VU' or 'PPM', these terms are used somewhat loosely to describe the type of response of the instruments. The meters do not and cannot conform to either VU nor BBC or IEC PPM standards since, among other things, the size, scale arc, scale markings and colour of the meter scale are specified. These specifications clearly cannot be duplicated by LED indicators.

Why and Wherefore?

Before looking at the details of the design it may be instructive, especially for the less experienced reader, to look at the why's and wherefores of signal level meters. In a perfect world signal

level meters would be superfluous for many applications. Sound from any source could be recorded on to tape or disc with no reference to the signal level. The only adjustment necessary would occur during playback, when the volume control of our (perfect) amplifier would be adjusted to give a sound level acceptable to our ears.

Regrettably the real world is very imperfect. To begin with, the lowest signal level that can usefully be recorded is determined by the noise generated by the recording and/or transmitting medium itself in the absence of a signal. In the case of disc this is caused by the surface texture of the disc material, in the case of tape, by random orientation of the magnetic domains. At the other extreme, the maximum signal level is determined for tape by the level at which the tape 'saturates', i.e. when the signal level versus magnetisation graph becomes non-linear, thus distorting the signal. In the case of disc the upper limit is determined by the tracking ability of the cartridge and, to a lesser extent, that of the cutting lathe.

The electronic circuits used to process the signal also have upper and lower signal limits due to noise on the one hand and distortion due to clipping on the other. In a recording/reproducing situation however, the limits imposed by the recording medium are much narrower than those imposed by the electronics.

This brings us to the concept of dynamic range, which is simply the ratio between the highest usable signal level and the lowest. This may be expressed as a ratio, e.g. 1000:1, but is more usually expressed in dB (decibels). There is nothing mystical or magical about the use of decibels, a voltage ratio expressed in dB is simply $20 \log_{10} V_1/V_2$. Thus the dynamic range of 1000:1 expressed in dB would be $20 \log 1000$. $\log 1000 = 3$ so the dynamic range = 60 dB. It is most important to note that this tells nothing about the magnitude of the quantities involved, merely their ratio. If some absolute quantity such as a voltage is to be expressed in dB then a reference voltage must first be chosen against which to express it. Thus, for example, the mains voltage (250 V) could be quoted as 60 dB (reference 0 dB = 250 mV).

There are many reasons for using dB rather than simple ratios. Firstly, human sense organs tend to respond to stimuli in a logarithmic fashion, so if electronic instruments such as signal level meters are scaled in dB then their response will be similar to that of the human ear (disregarding frequency response). Secondly, when dealing with dynamic ranges of many thousands of times, it would be impossible to construct an instrument with a linear scale that could read both the lowest and highest signal levels without changing ranges. Thirdly, since ratios expressed in dB are simply logarithms, to express the product of several quantities such as the overall gain of a number of amplifiers and/or

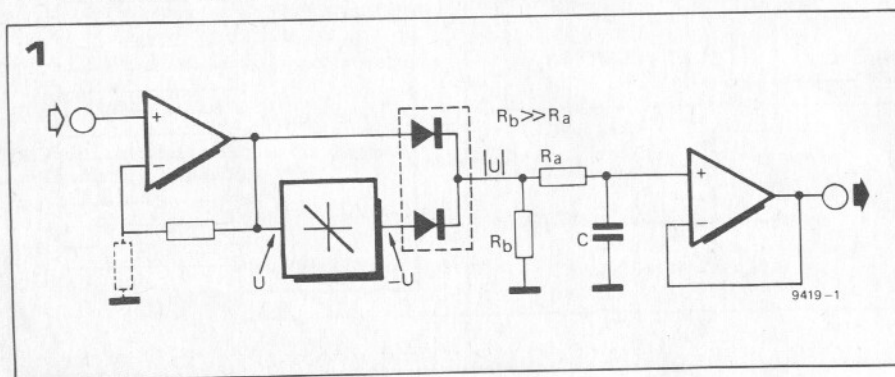

2

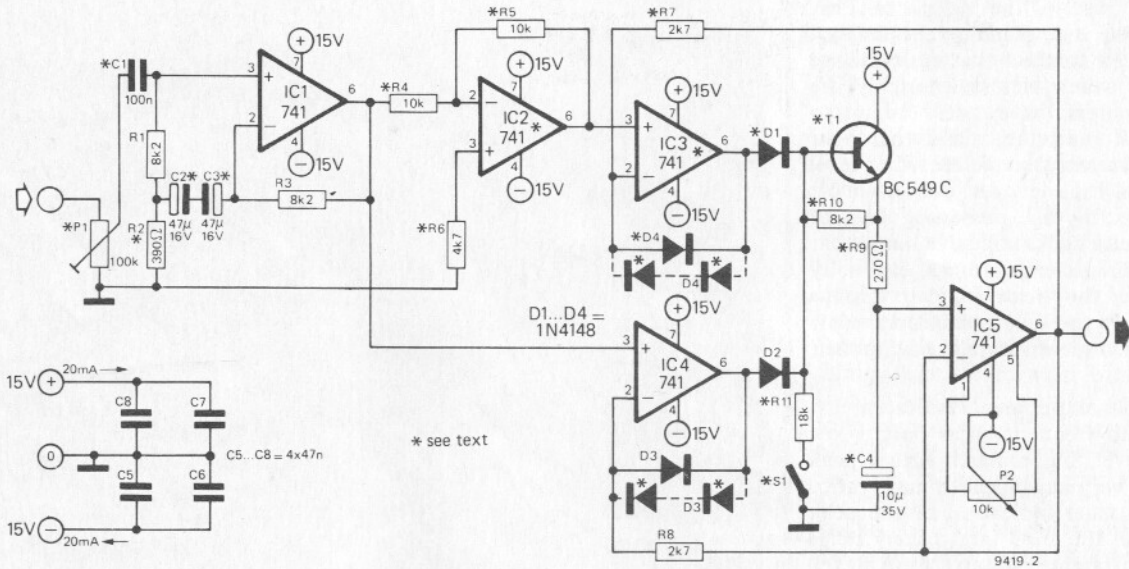

attenuators in cascade it is necessary merely to add up the dB gain/attenuation of each stage rather than multiplying the straight ratios. This makes life much simpler.

Meter Characteristics

This may seem something of a digression from the why's and wherefores of signal level meters, however, from the foregoing it is possible to make the following conclusions.

1. Signal level meters are required for the following reasons:

a. To set the limits of the signal within the dynamic range of the recording/reproducing chain.

b. When making multichannel recordings (including plain stereo) to set the balance between the different channels. This is particularly important in recordings studios using multi-mike techniques and umpteen-channel mixing desks.

c. The dynamic range of live sound is much greater than can be accommodated by the recording medium. It is around 120 dB, determined on the one hand by the softest sound that can be heard, and on the other by the threshold of pain. Since a tape or disc might have a dynamic range of only 50 to 60 dB it is necessary to turn up the recording level during quiet passages so that the signal is not masked by the noise, and to turn the level down during loud passages, so that the equipment is not overloaded. Of course automatic compressors can be used in this situation, but manual adjustment by a skilled engineer is frequently less noticeable.

2. From the earlier discussion it is evident that a signal level meter should have a logarithmic (dB) scale.

PPM or VU?

Since the average value of a symmetrical AC waveform is zero, before the signal level can be measured with any sort of DC meter it must first be rectified. If the rectified waveform is fed to a DC

voltmeter then, due to the mechanical inertia of the meter movement, the meter will tend to indicate the average voltage of the waveform. So that the meter needle does not tend to follow the waveform at low signal frequencies (which would make it difficult to read) the inertia of the meter must be fairly high. This is the basic principle of the VU meter.

However, a meter that is sufficiently well damped for the needle not to jitter at low frequencies will also be unable to repond quickly to short transients. This means that the meter will tend to underestimate peaks,

Figure 1. Showing the principle of full-wave rectification of the audio signal, and the attack and decay time constants.

Figure 2. Complete circuit of the rectifier section of the meter.

Figure 3. Showing how, in a VU meter the voltage on C4 builds up until equilibrium is reached between charge and discharge.

Figure 4. For half-wave 'VU' measurement the inverting half of the rectifier section may be omitted.

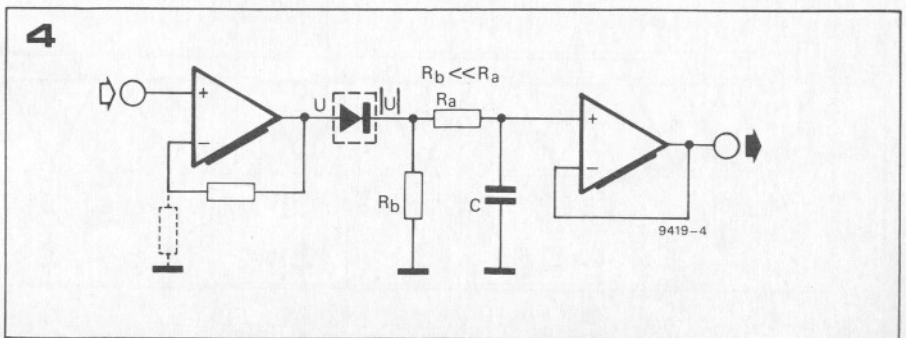
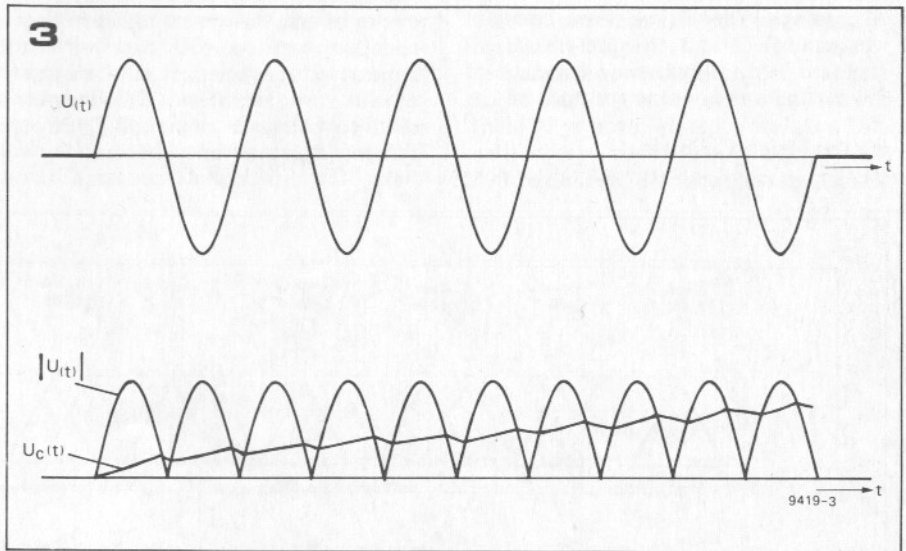

leading to overrecording, and this has been a criticism of the VU meter. That this criticism is to some extent justified is verified by the fact that cassette tape recorders, which almost invariably use VU-like meters, have lately begun to sport peak indicator lamps that light when the maximum safe recording level is exceeded by a few dB, even on short transients. Anyone possessing one of these cassette decks will have noted that when making live recordings, especially of speech, the peak indicator lamps can be made to flash merrily on and off with the VU meters barely leaving their end stops.

This simple experiment indicates that 'live' sound frequently has only a low average level, but a much higher peak level i.e. a very large peak to mean ratio. To give a truer indication of the peak signal level the BBC (and other) PPMs (Peak Programme Meters) were developed. These instruments were designed to respond very quickly to increase in signal level, but for ease of reading the meter reading was made to die away at a much slower rate. To put it another way, the PPM has a short attack time constant and a long decay time constant. The original PPMs had an extremely fast attack. However, later experiments in psycho-acoustics showed that the ear is unable to perceive distortion caused by short duration clipping (e.g. less than 10 ms). This means that overrecording of short transients is allowable, provided no undesirable effects occur such as blocking of amplifiers or r.f. bursting, and in this situation the original PPM tended to overestimate the effect of peaks.

Accordingly the attack time constant was modified, and the present (BBC) standard is an attack time constant of 2.4 ms and a decay time constant of 1 s.

Meter Drive Circuits

In the conventional VU meter and PPM

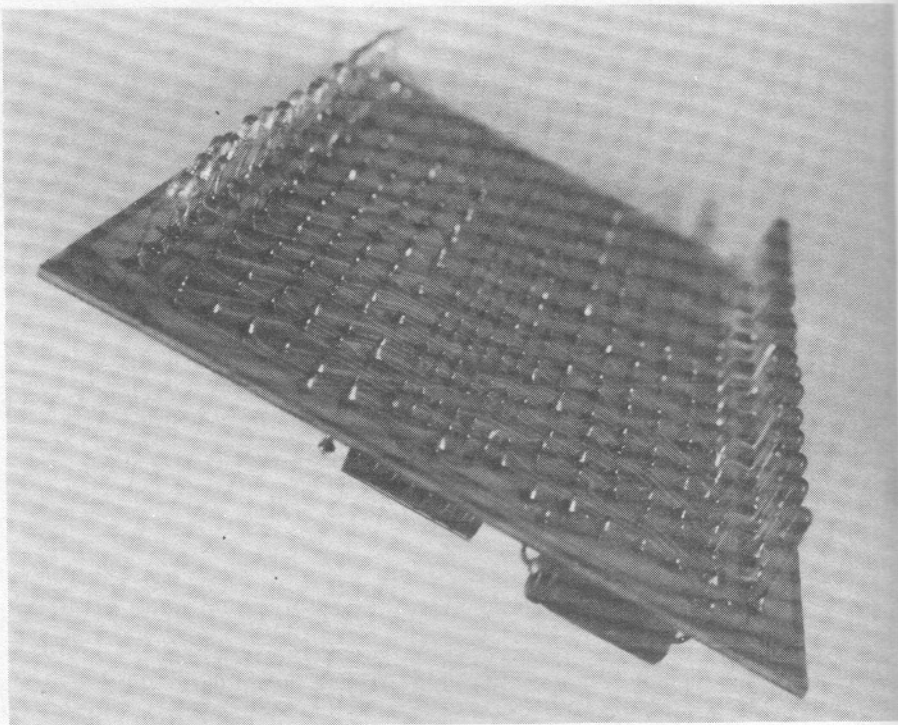

the ballistics of the meter movement play a great part in determining the time constants and are very tightly specified. However, the present design is to use a line of LEDs instead of a moving coil instrument, so the meter characteristics are determined entirely by the electronics.

Figure 1 shows a block diagram of the drive circuitry for the PPM. The signal is first buffered and if necessary amplified before being fed to two rectifiers. The signal to one rectifier is inverted so that this rectifier operates on negative half-cycles of the waveform, and a full-wave rectified version of the waveform appears at the junction of the outputs of the two rectifiers. This output is used to charge a capacitor C through resistor R_a , the time constant $R_a \cdot C$ being the attack time constant. C can

Figure 5. Complete circuit of the LED display with logarithmic divider chain. This gives a DIN-type PPM scale (Table 4) but can be adapted to give a BBC-type PPM (Table 3) or VU scale (Table 2).

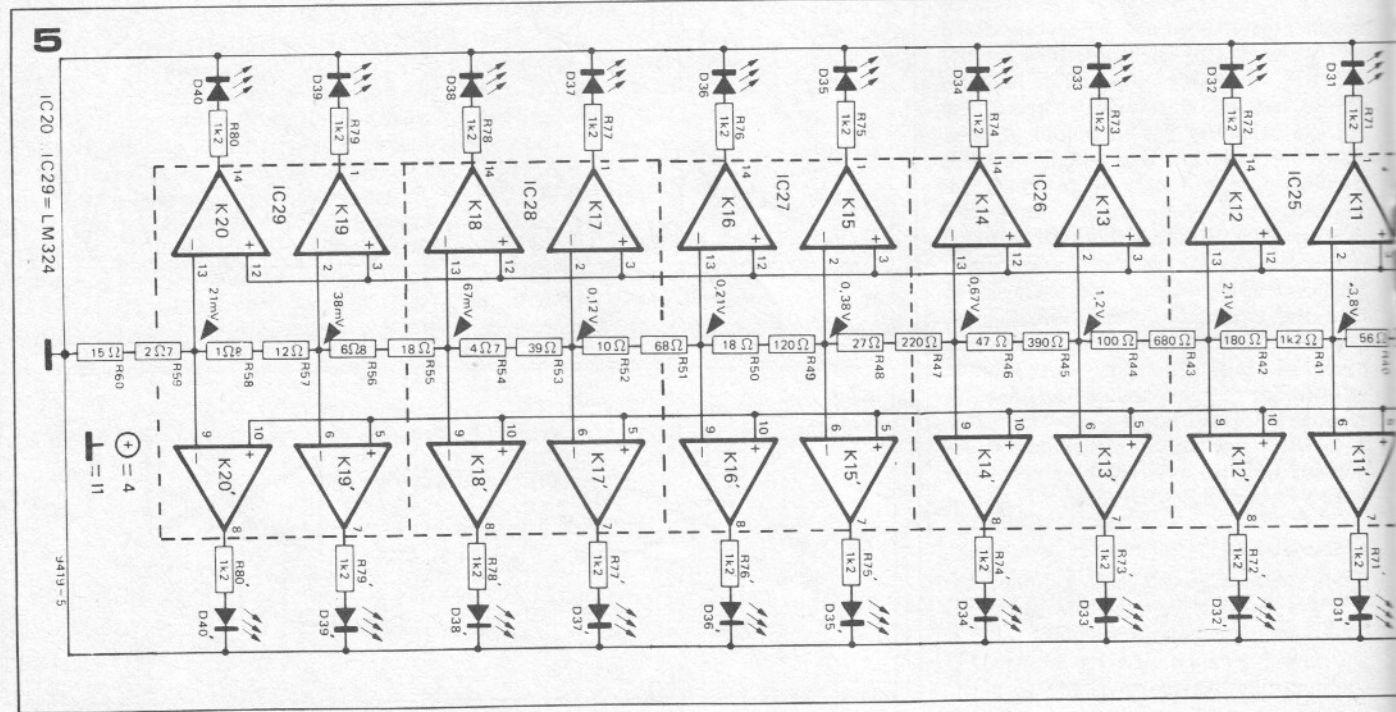

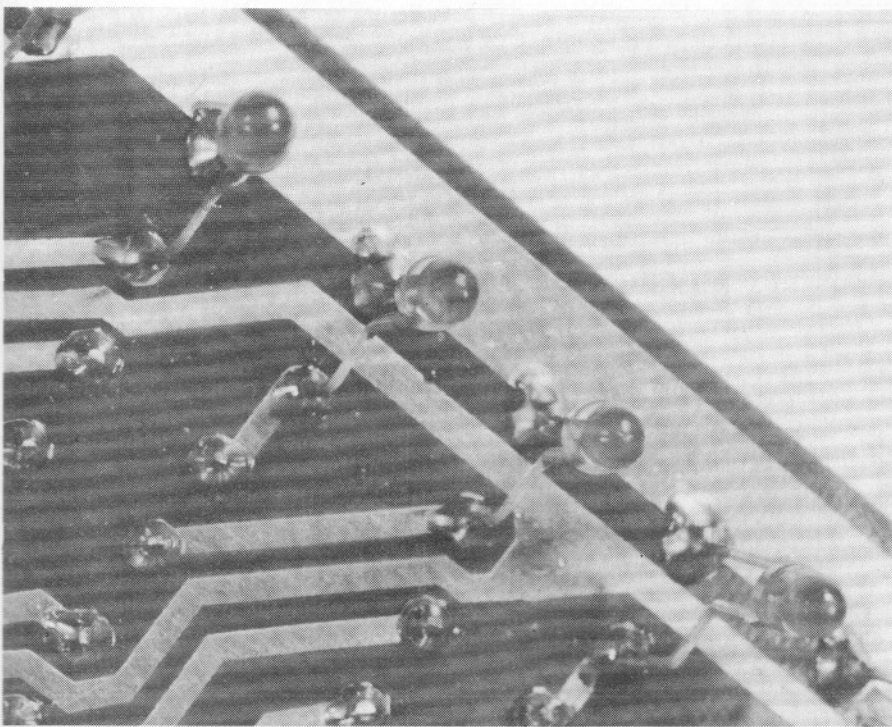

discharge through R_a and R_b . R_a , R_b and C are chosen to give the time constants mentioned earlier. To avoid the output from C being loaded by the following circuits a high input impedance buffer is provided.

Operation of the VU meter drive circuit is very similar. The only difference is that R_b is very small compared to R_a , so the attack and decay time constants are virtually identical.

Figure 2 shows the complete circuit of the meter drive. IC1 functions as a non-inverting amplifier with a gain of

$$\frac{R_2 + R_3}{R_2}$$

Bootstrapping of R_1 at the junction of R_2 and C_2 increases the input impedance. The reverse series connection of C_2 and C_3 is necessary since the DC voltage on pin 2 of IC1

can be either slightly positive or slightly negative. A $22\ \mu$ reversible electrolytic could also be used here.

IC2 functions as a unity gain inverter, and the inverted and non-inverted signals are fed to IC3 and IC4 respectively, which form the two halves of the rectifier circuit. The rectifier circuit is of the active type, and eliminates the effect of the forward voltage drop of the diodes, which could otherwise cause gross errors in the measurement of low signal levels.

The rectifier configuration shown offers some interesting possibilities, depending on how diodes D_3 and D_4 are connected. With the diodes connected as shown the circuit operates as follows: assuming that the circuit is in the quiescent condition the outputs of IC3 and IC4 are at zero volts. Since there is

no bias voltage across D_3 or D_4 IC3 and IC4 have no feedback and are thus operating open-loop. On positive half-cycles of the input signal the output of IC4 will swing rapidly positive until it clips. D_2 will conduct, T_1 will conduct and C_4 will charge rapidly from T_1 via R_9 . IC5 is connected as a voltage follower, so its output will be equal to the voltage on C_4 . This provides negative feedback to the inverting input of IC4. The voltage on C_4 will thus stabilise at a level equal to the peak value of the input voltage.

During this time the output of IC3 will swing negative, forward biasing D_4 so that IC3 simply operates as a voltage follower following the (negative) output of IC2. D_1 is thus reverse-biased, so no negative voltage appears on the base of T_1 .

On negative half-cycles of the waveform the situation is reversed. The output of IC3 swings positive and causes D_1 and T_1 to conduct, while the output of IC4 goes negative, reverse-biasing D_2 . The discharge path for C_4 is through R_9 , R_{10} and R_{11} , since IC5 presents a very high input impedance and thus has little effect on the discharge time. The ratio of R_{10} to R_{11} is chosen so that the voltage on C_4 cannot cause reverse emitter base breakdown of T_1 in the absence of a signal.

S_1 can be opened to remove the discharge path and provide a 'peak memory', which can be useful when making 'dry-runs' of recording sessions to find the maximum level of the signal.

This 'Elektor Standard' system provides a peak rectifier with an extremely fast rise time. However, to make a rectifier with characteristics corresponding to that of a BBC or DIN PPM or VU meter, several changes must be made.

If the circuit is to be used as a VU meter then T_1 is not required since the attack and decay times are relatively long (300 ms). The charging current of the

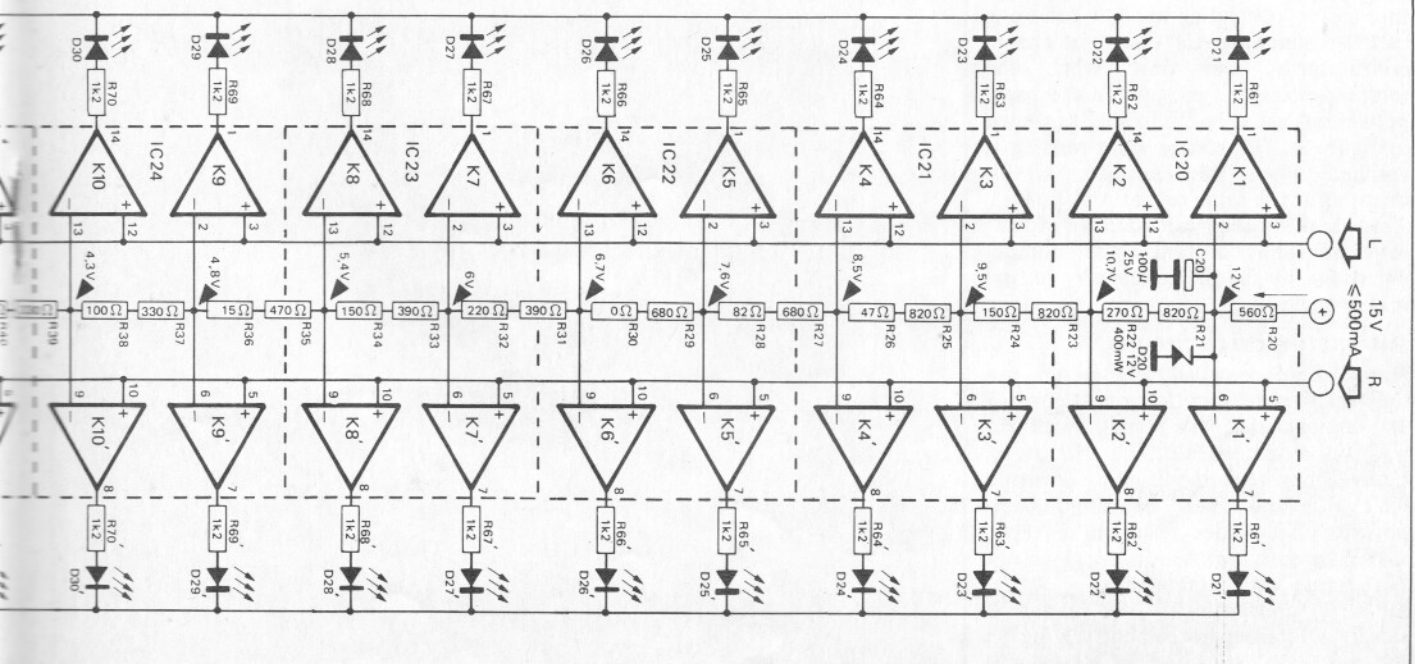

1

Table 1.

Component values for different response characteristics.

	Elektor PPM	DIN PPM	BBC PPM	VU METER
R9	270 Ω	68 Ω	100 Ω	100 k
R10	8k2	10 k	12 k	0 Ω
R11	18 k	18 k	33 k	10 k
C4	10 μ (1)	22 μ (1)	22 μ (1)	330 n
D3	1N4148	2 x 1N4148 reversed		1 x 1N4148 reversed
D4	1N4148	2 x 1N4148 reversed		1 x 1N4148 reversed
T1	BC549C or equivalent			omitted

(1) Tantalum 20% tol. 16 V.

capacitor is smaller and can easily be provided by the outputs of IC3 and IC4 direct. R10 is replaced by a wire link, R9 becomes 100 k, R11 - 10 k and C4 - 330 n.

Diodes D3 and D4 are reversed. This may seem a little strange, but the circuit now operates as follows: on positive half cycles the output of IC4 will swing positive in an open-loop mode until D3 begins to conduct, after which IC4 will operate as a voltage follower. The voltage at the output of IC4 is thus equal to the input voltage plus the forward voltage of D3. D2 is forward biased and its voltage drop cancels that of D3, so the voltage at its cathode is equal to the input voltage to IC4. C4 will charge from IC4 through D2 and R9. On negative half-cycles the output of IC3 will swing positive and C4 will charge via D1 and R9. D4 discharges through R9 and R11, but since R11 is small compared to R9 the attack and decay time constants are similar.

The problem now arises as to how to calculate the required time constants. The specification for a VU meter states that if a 1 kHz sinewave, whose amplitude is such as to give a steady state reading of 100, is suddenly applied, the reading on the VU meter shall reach 99 within 300 ms. If it was a simple step function that was applied to the meter then the time constant would be simple to calculate. Unfortunately, since the meter is dealing with a full-wave rectified sinewave C4 does not charge continuously, but only when the rectified voltage is present. In the 'gaps' between it actually discharges, as shown in figure 3. The steady state reading is reached when the capacitor is discharging at the same rate as it charges. This makes the calculation of the required time constant rather complicated and by far the easiest way to find it is empirically.

Alternative drive circuits

Many cheap so-called VU meters use only half wave rectification (figure 4) and assume that the signal waveform will be symmetrical. The circuit of figure 2 may be so modified by omitting IC2, IC3 and their associated components. This does result in a slight saving in cost, but the meter does not have a true VU characteristic.

Since a conventional VU meter is simply a rectifier instrument relying on the meter ballistics for its attack and

decay times it is fairly easy to simulate electronically. However, the attack time of a conventional PPM is determined by two factors, the meter ballistics and the electrical time constant of the rectifier circuit. This makes it more difficult to simulate accurately without using a more complex double time constant circuit. Some compromise must thus be found.

The standard for a BBC type PPM (BS 4297:1968) states that if a 5 kHz signal (whose steady state value would give a reading of mark 6 on the PPM scale) is applied in a 5 ms burst the reading will be 4 dB below mark 6. To obtain this reading the attack time constant must be about 2.5 ms. Since the attack of a genuine PPM is more complex this necessarily results in small errors at other scale points. The decay time constant of the BBC PPM is 1 s, and the decay time is largely independent of the meter ballistics, since these are swamped by the long time constant. The specification for a PPM to DIN 45406 states that a 5 ms tone burst shall give a reading 2 dB below the steady state reading. Here an attack time constant of 1.5 ms is a reasonable compromise. The decay time of the DIN PPM is 650 ms.

Since the attack time constants of PPMs

are much shorter than that of a VU meter the value of R9 and/or C4 must be reduced. To obtain a value of R9 that could be driven direct from the 741 outputs C4 would need to be less than 1 μ , which means that R11 would be greater than 1 M. This is unacceptable as the input currents of IC5 would then have a significant effect on the decay time. To overcome this T1 must be reinstated so that smaller values of R9 and R11 and a larger value of C4 can be used. However, the base emitter junction of T1 then introduces an extra voltage drop, which must be eliminated. The solution is an extra diode in series with both D3 and D4.

To clarify matters the component values for the 'Elektor Standard' PPM, BBC and DIN PPMs and VU meter are given in Table 1. These values may of course be altered to suit personal taste and/or any other standards.

Display

Having obtained a voltage which increases and decreases with the appropriate time constants in response to a signal, the question now is how to convert it to a suitable display. Established readers of Elektor will be familiar with the ICs manufactured for this purpose by Siemens. These consist of a chain of analogue voltage comparators each having one input tied to a reference voltage from a potential divider, the other input being connected to the signal voltage and the output to a LED. When the input voltage exceeds the reference voltage the comparator output goes low and lights the LED. The higher the input voltage the more LEDs in the chain there are lit.

Unfortunately the response of these LED voltmeters is linear, whereas a logarithmic response is required for a signal level meter. One possibility would be to precede one of the Siemens ICs by

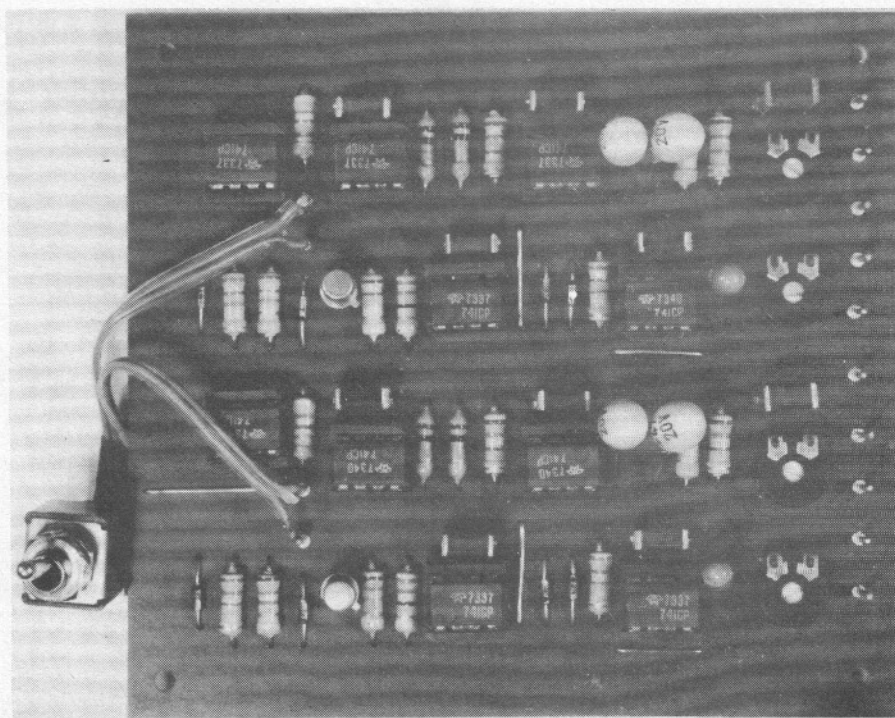

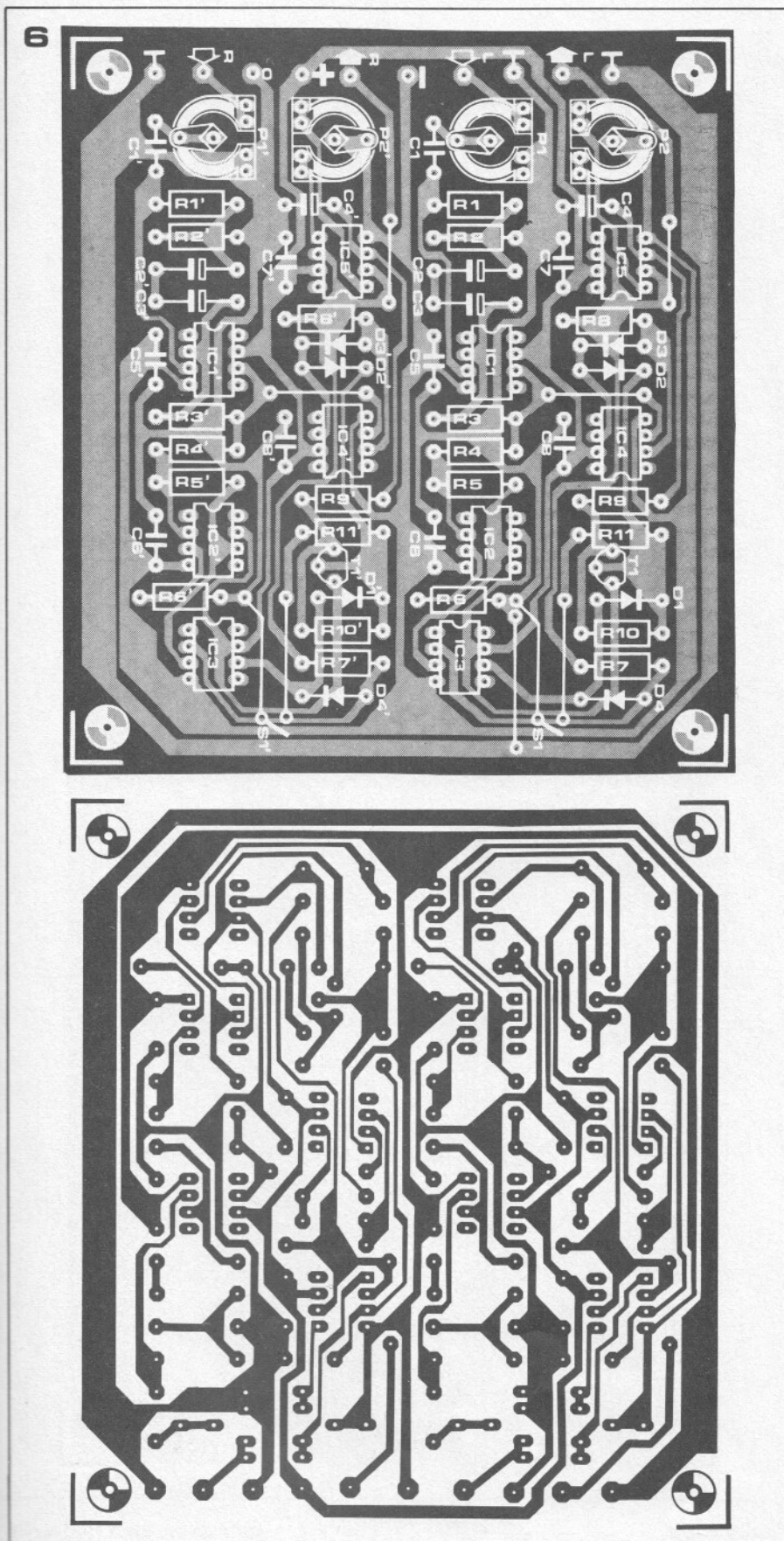

Parts list for figures 2 and 6:

Resistors:

R1, R3 = 8k2
 R2⁽¹⁾ = 390 Ω
 R4⁽²⁾, R5⁽²⁾ = 10 k
 R6⁽²⁾ = 4k7
 R7⁽²⁾, R8 = 2k7
 R9 = see text and Table 1
 R10 = see text and Table 1
 R11 = see text and Table 1
 P1⁽¹⁾ = 100 k
 P2 = 10 k

Capacitors:

C1⁽¹⁾ = 100 n
 C2⁽¹⁾, C3⁽¹⁾ = 47 μ /16 V
 C4 = see text and Table 1
 C5, C6, C7, C8 = 47 n

Semiconductors:

IC1, IC2⁽²⁾, IC3⁽²⁾, IC4, IC5 = 741
 D1⁽²⁾, D2 = 1N4148 or 1N914
 D3, D4⁽²⁾ = see text and Table 1
 T1⁽³⁾ = BC109C, BC549C or equivalent

Miscellaneous:

S1⁽³⁾ = DPST switch

Notes:

- 1: See 'Calibration'.
- 2: Omitted for half-wave VU measurement.
- 3: Omitted for VU measurement.

Table 1. Component values to modify figure 2 for different response characteristics.

Figure 6. Printed circuit board and component layout for the rectifier section (EPS 9419-1).

a logarithmic amplifier. However, these can be somewhat critical in operation, and a much simpler solution is to design a LED voltmeter using discrete comparators but, unlike the IC versions, having a logarithmic potential divider network.

The complete circuit for a stereo version of the indicator is given in figure 5. The

'law' of the logarithmic potential divider is shown in the second column of Table 4. It will be seen that around the 0 dB level the steps are 1 dB, but at lower levels the steps are made much coarser (5 dB). This means that the meter has the best resolution in the most useful part of its range. This corresponds to the scaling of a DIN PPM, but

can easily be altered to give BBC PPM and VU type scales as will be explained later.

Construction

A printed circuit board and component layout for a two-channel version of the rectifier circuit are given in figure 6, and for the display unit in figure 7. The

2

Table 2.

Components for VU type display scale.

Resistors:

R21 — R28 = 0 Ω (wire links)
 R29, R31, R33, R55 = 1 k
 R30, R53 = 270 Ω
 R32 = 100 Ω
 R34, R48, R60 = 0 Ω
 R35 = 820 Ω
 R36, R44, R50 = 68 Ω
 R37, R43, R45, R47 = 470 Ω
 R38, R49, R51 = 330 Ω
 R40 = 390 Ω
 R41, R57 = 560 Ω
 R42, R58 = 56 Ω
 R46 = 33 Ω
 R52 = 22 Ω
 R54 = 47 Ω
 R56 = 120 Ω
 R57 = 18 Ω
 R59 = 820 Ω
 R61 — R64 and R61' — R64' = omitted

Semiconductors:

IC20, IC21 (K1 — K4 and
 K1' — K4') = omitted
 D21 — D24 and D21' — D24' = omitted
 All other components as per figure 5.

3

Table 3.

Components for 'BBC PPM' type display scale.

Resistors:

R21 — R30 = 0 Ω (wire links)
 R31 = 3k3
 R32 = 2k7
 R33 = 1k2
 R34, R37 = 560 Ω
 R35 = 1 k
 R36, R40, R43 = 270 Ω
 R38 = 39 Ω
 R39, R41 = 330 Ω
 R42 = 68 Ω
 R44, R46 = 33 Ω
 R45 = 220 Ω
 R47 = 180 Ω
 R48, R54 = 22 Ω
 R49 = 150 Ω
 R50, R52, R56, R58, R60 = 0 Ω
 R51, R53, R57, R59 = 120 Ω
 R55 = 100 Ω
 R61 — R65 and R61' — R65' = omitted

Semiconductors:

IC20, IC21 (K1 — K4 and
 K1' — K4') = omitted
 D21 — D25 and D21' — D25' = omitted
 All other components as per figure 5.

7

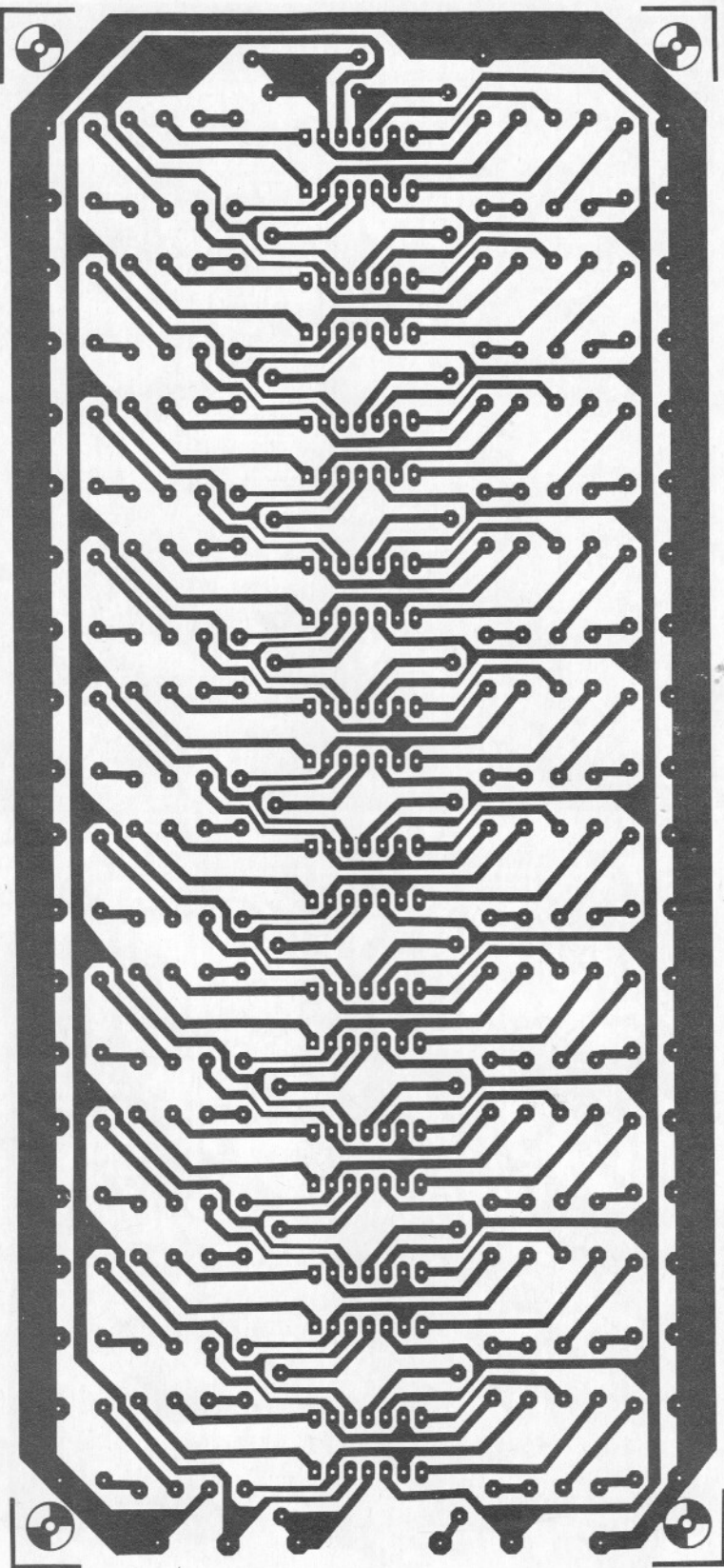

accompanying photographs show the construction of the complete unit. Of course it is not mandatory to mount the LEDs on the back of the p.c. board as shown. If panel width is at a premium the LEDs can be mounted separately on a piece of veroboard and the p.c. board can then be mounted edge on to the front panel.

Calibration

Having checked for any wiring errors, before connecting the rectifier and display boards a few simple checks can be carried out. Firstly, apply power to the display board and check that, with the input grounded, no LEDs are lit, and with the input connected to +15 V all LEDs are lit.

Secondly, with power applied to the rectifier board, adjust P2 in both

channels to give a null (zero volts) at the output of IC5. It may be necessary to swap around the 741s to find the one with the best offset characteristics, so it is a good idea to mount them in sockets.

Having carried out these checks the two boards may be linked together and the whole system tested by applying a sine wave signal to the inputs and varying the input level. Calibration of the meter

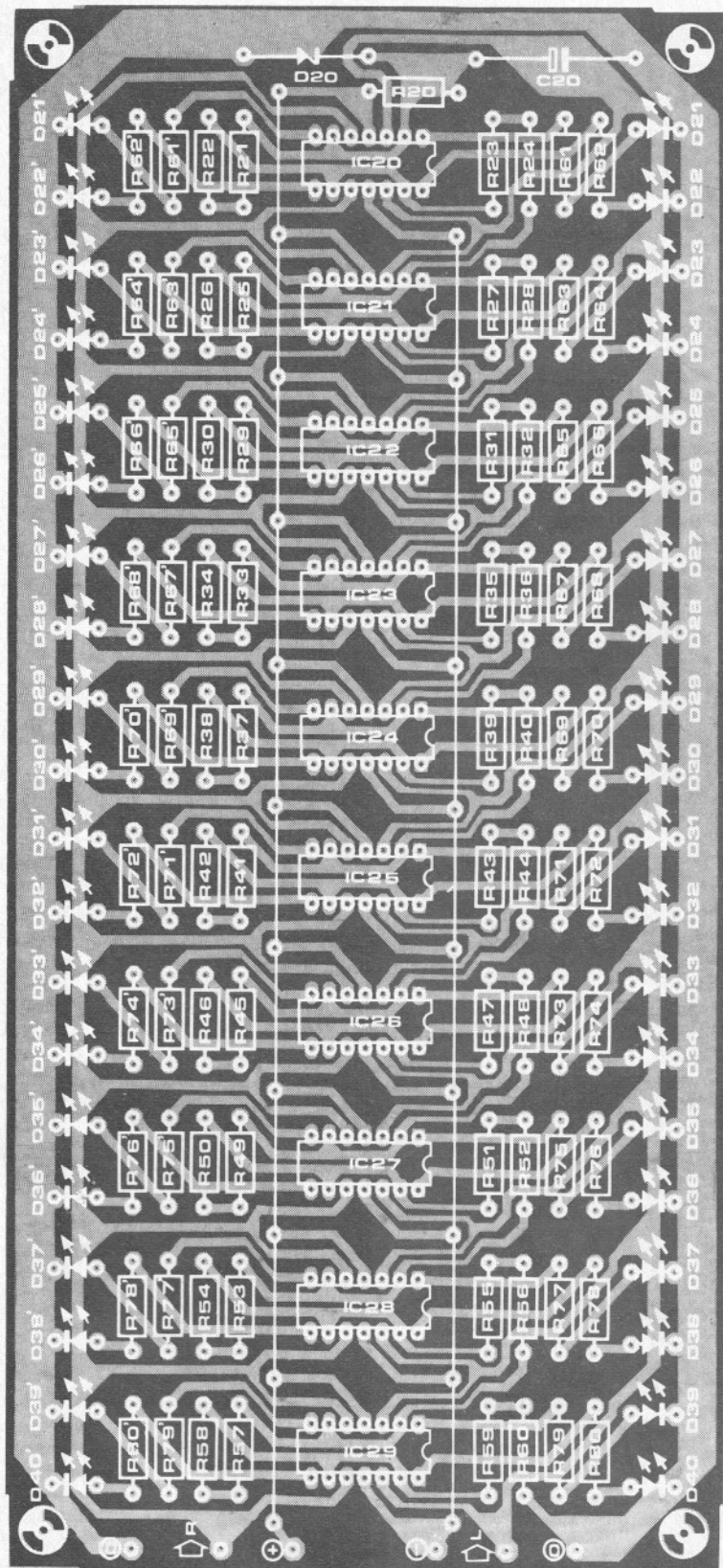

Figure 7. Printed circuit board and component layout for the display (EPS 9419-2).

Table 2. Component modifications for VU-type display.

Table 3. Component modifications for BBC PPM-type display.

depends on the maximum signal level likely to be encountered in the system. In any event, to calibrate the PPM version the unit must be fed with a sine wave signal having a peak value equal to the maximum peak signal level. P1 is then adjusted until all LEDs up to the 0 dB LED are lit.

To calibrate the VU meter it must be remembered that the average value of the signal is being measured, so the peak

Parts list for figures 5 and 7.

Resistors:

R20 = 560 Ω
 R21, R23, R25 = 820 Ω
 R22 = 270 Ω
 R24, R34 = 150 Ω
 R26, R46 = 47 Ω
 R27, R29, R43 = 680 Ω
 R28 = 82 Ω
 R30 = 0 Ω (link)
 R31, R33, R45 = 390 Ω
 R32, R47 = 220 Ω
 R35 = 470 Ω
 R36, R60 = 15 Ω
 R37, R39 = 330 Ω
 R38, R44 = 100 Ω
 R40 = 56 Ω
 R41, R61⁽¹⁾ - R80⁽¹⁾ = 1k2
 R42 = 180 Ω
 R48 = 27 Ω
 R49 = 120 Ω
 R50, R55 = 18 Ω
 R51 = 68 Ω
 R52 = 10 Ω
 R53 = 39 Ω
 R54 = 4.7k
 R56 = 6.8k
 R57 = 12 Ω
 R58 = 1.5k
 R59 = 2.2k

Capacitors:

C20 = 100 μ /25 V

Semiconductors:

IC20 - IC29 (K1 - K20) = LM324
 D20 = 12 V 400 mW zener
 D21 - D25 = red LED⁽¹⁾
 D26 = yellow LED⁽¹⁾
 D27 - D40 = green LED⁽¹⁾

Notes:

1: See 'Adaptions' and Tables 2 and 3. Note that, for the stereo display, R61 to R80 and D21 to D40 are duplicated. IC20 to IC29, R20 to R60, C20 and D20 serve both channels.

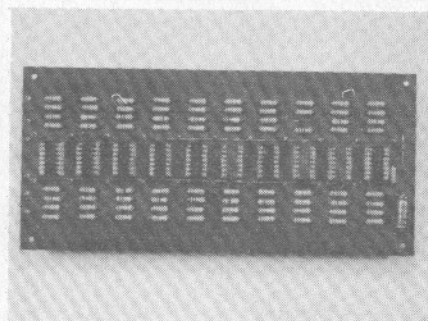

value of the input signal must be $\pi/2$ or 1.57 times higher. If the half-wave 'VU' circuit is used then, since only half the waveform is utilised the peak value of the input signal must be π times greater. To put it another way, if the same signal level is to give a 0 dB reading on both PPM and VU measurements then P1 will need to be turned up further in the VU meter.

If the meter is to be used to monitor the

output of a high signal circuit such as a power amplifier then there is no need for IC1 to have any gain and it can simply be used as a voltage follower. In that case C2 and C3 are omitted, R2 is replaced by a wire link, P1 becomes 10 k and C1 becomes 1 μ .

Adaptations

1. The scaling of the meter is -50 dB to $+5$ dB in accordance with DIN 45406 and the IEC proposal of September 1970. However, the display p.c. board is almost universal in scope and can be altered to give virtually any desired scale. This is achieved simply by altering the resistors in the potential divider chain and/or the number of comparators and LEDs. The modifications required to give a VU-type scale (-20 to $+3$ dB) are given in Table 2. Modifications to give a BBC PPM-type scale are given in Table 3.

2. The time constants of the rectifier circuit can be adjusted to suit personal taste. There are various 'standards' for peak reading meters, none of which agree with one another. If one wishes to stick to a particular standard, however, then the appropriate time constants should be used. The appropriate display scaling should also be used.

3. The current through the LEDs (and hence their brightness) can be varied by choosing different values for the series resistors. However the resistors should not be chosen so low that the current rating of the LEDs is exceeded.

4. The $+15$ volt supply must be well decoupled by a $100 \mu/35$ V capacitor to avoid transients appearing on the supply line due to the large current drawn by T1 and the LEDs on transient signal peaks. The $+15$ V supply should be capable of delivering 500 mA. The -15 V consumption, however is only about 20 mA.

5. Since 741s have a limited slew rate the h.f. response of the rectifiers may be somewhat limited, since for the first part of their output swing the 741s are operating open loop. Perfectionists may like to experiment with faster op-amps such as the 748 or 531. Such ICs, of course, require external frequency compensation, so would-be experimenters are advised to consult the manufacturer's data.

6. The LED colours may be changed to suit personal taste, but it is a good idea to arrange that the display colour changes to indicate an overload e.g. green below 0 dB, yellow at 0 dB and red above 0 dB. ■

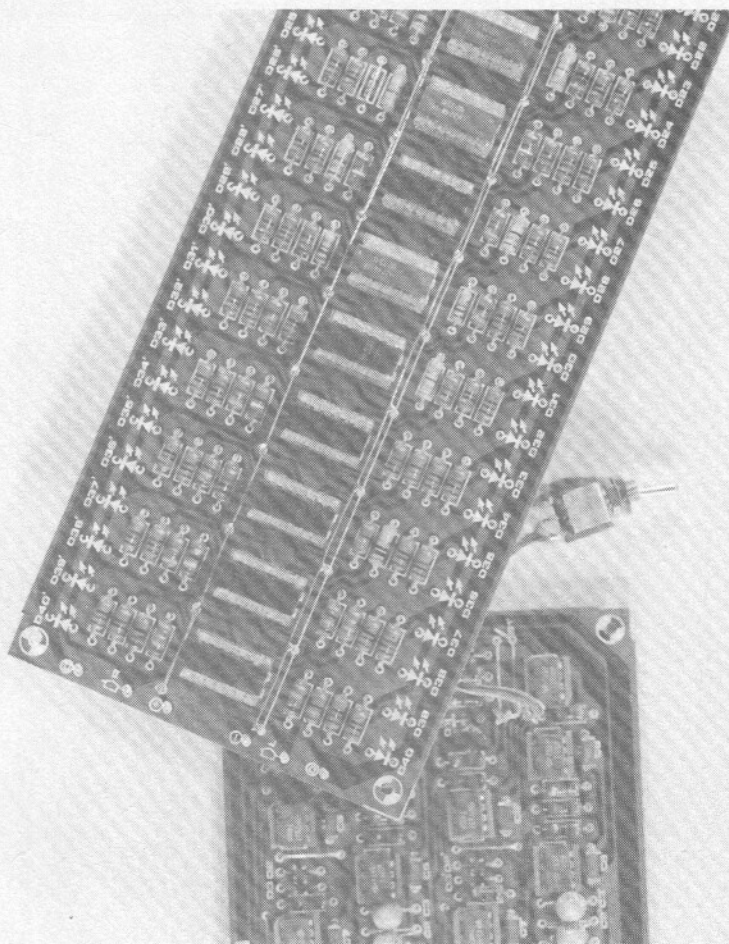

Table 4. Scale layout of the three types of display.

4

Table 4.

'DIN PPM' type scale parameters.			'BBC PPM' type scale parameters.				VU type scale parameters.		
LED	PPM Level (dB)	Absolute voltage applied to display input (volts)	LED	dB Level	PPM reading	Absolute level at display input (volts)	LED	VU Level	Absolute level at display input (volts)
D40	-50	.021	D40	-20	unspecified	0.12	D40	-20	0.85
D39	-45	.038	D39	-14	1	0.24	D39	-15	1.51
D38	-40	.067	D38	-11	1.5	0.34	D38	-10	2.68
D37	-35	.12	D37	-8	2	0.48	D37	-9	3.01
D36	-30	.21	D36	-6	2.5	0.6	D36	-8	3.38
D35	-25	.38	D35	-4	3	0.75	D35	-7	3.79
D34	-20	.67	D34	-2	3.5	0.95	D34	-6	4.28
D33	-15	1.2	D33	0	4	1.2	D33	-5	4.77
D32	-10	2.1	D32	+2	4.5	1.5	D32	-4	5.36
D31	-5	3.8	D31	+4	5	1.9	D31	-3	6.02
D30	-4	4.3	D30	+6	5.5	2.5	D30	-2	6.75
D29	-3	4.8	D29	+8	6	3	D29	-1	7.57
D28	-2	5.4	D28	+11	6.5	4.26	D28	0	8.5
D27	-1	6	D27	+14	7	6.01	D27	+1	9.53
D26	0	6.7	D26	+20	unspecified	12	D26	+2	10.7
D25	+1	7.6					D25	+3	12
D24	+2	8.5							
D23	+3	9.5							
D22	+4	10.7							
D21	+5	12							

signal injector

J.W. van Beek

Many people consider the use of signal injectors to be something of a 'brute force' method of faultfinding. However, a signal injector can easily be carried around in the pocket and is often the service engineer's 'first line of defence' when undertaking repairs in the customer's home. Certainly a signal injector is much more portable than an array of sophisticated signal generators.

Most of the cheap signal injectors on the market produce a squarewave output at about 1 kHz. Since the squarewave is rich in harmonics extending up into the Megahertz region these are useful for testing r.f. circuits, as well as using the fundamental for audio testing.

The signal generator described here differs slightly in that the 1 kHz squarewave is keyed on and off at about 0.2 Hz, which makes it easier to trace.

Figure 1 shows the complete circuit of the signal injector. The keying oscillator consists of an astable multivibrator built around two CMOS NAND gates N1 and N2. This switches on and off T1, which drives a LED to indicate when the signal is on. The 1 kHz squarewave generator also consists of an astable multivibrator, which utilises the two remaining NAND gates in the 4011 package. This astable is gated on and off by the first astable. The output of the 1 kHz squarewave generator is buffered by transistors T2 and T3, the output being taken from the collector of T3 via a potentiometer P1 which serves to adjust the output level. The maximum output is approximately equal to the supply voltage (5.6 V). Diodes D1 and D2 provide some protection for T2 and T3 from external transients, and C6 isolates the circuit from any DC voltage in the circuit under test. If the signal injector is to be used to test circuits having high voltages present, especially mains (e.g. television sets) then C6 should be rated at 1000 V working, in which case it will be too large to mount direct on the p.c. board, the layout for which is given in figure 2. It is also a good idea to mount the complete circuit inside a box made of insulating material, especially when working on live chassis equipment such as a television set. D1 and D2 should be types capable of handling any transient voltages and currents likely to be encountered.

Power for the circuit can be provided by four 1.4 V mercury batteries. The exact type of battery chosen is up to the individual constructor, but should neither be so small that the battery life is too short, nor so large that the complete instrument is too bulky.

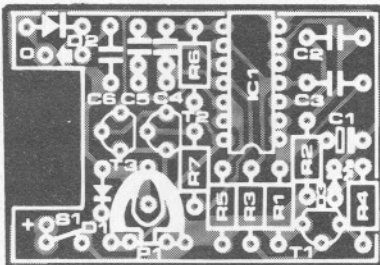
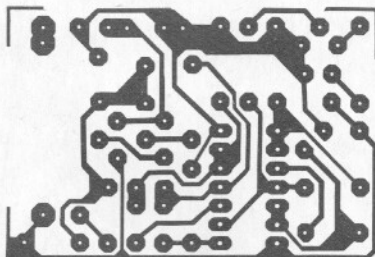

Parts List

Resistors:

- R1, R2, R5, R6 = 10 M
- R3 = 100 k
- R4 = 470 Ω
- R7 = 27 k
- P1 = 1 k preset

Capacitors:

- C1 = 100 μ/6 V
- C2, C3 = 470 n
- C4, C5 = 100 p
- C6 = 100 n/250 V (see text)

Semiconductors:

- IC1 = 4011
- T1 = TUP
- T2, T3 = TUN
- D1, D2 = DUS (see text)
- D3 = LED (e.g. TIL209)

Miscellaneous:

- S1 = SPST switch
- 4 x 1.4 V mercury batteries

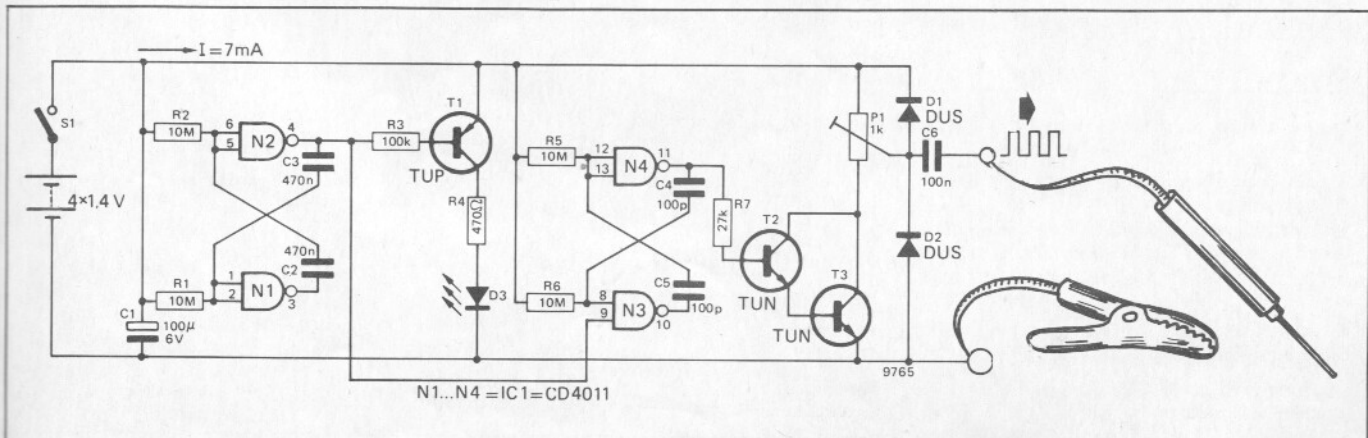

simple auto slide changer

W. Fröse

Automatic slide changers are extremely useful when a recorded commentary is used to accompany a programme of slides. Most auto slide changers make use of a control signal. This may be a high frequency low level signal, recorded on the same track as the commentary, which is unobtrusive but which may be extracted for control purposes by a filter. Alternatively, an audio tone may be recorded on a parallel track.

The slide changer described here uses neither of these methods but senses the drop in signal level of the commentary when the commentator stops speaking for more than one second.

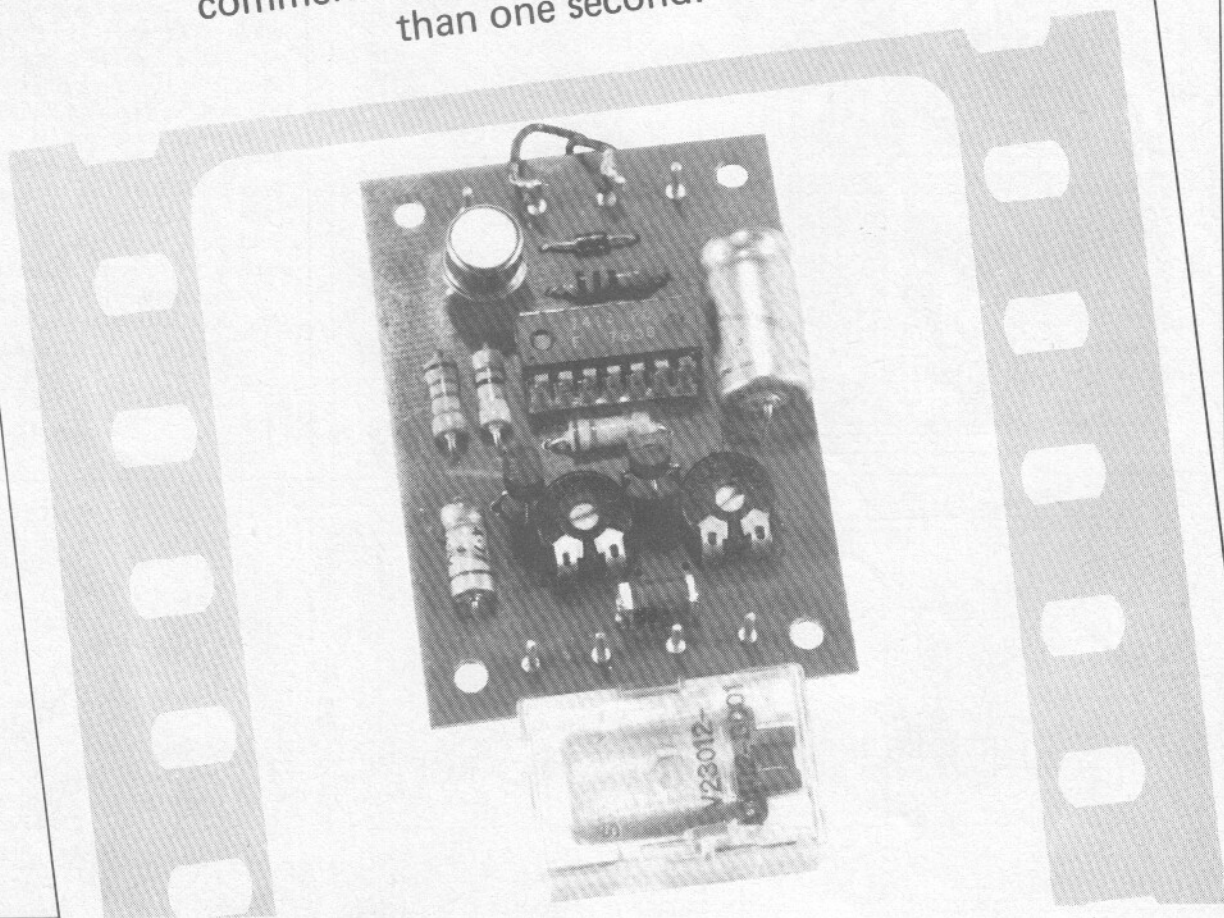

1

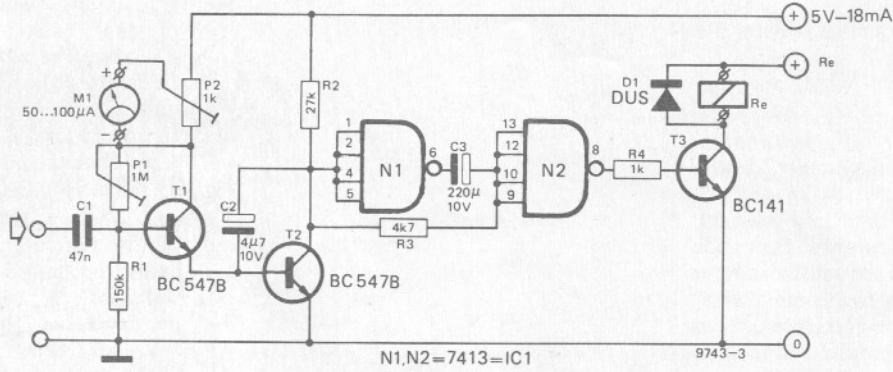
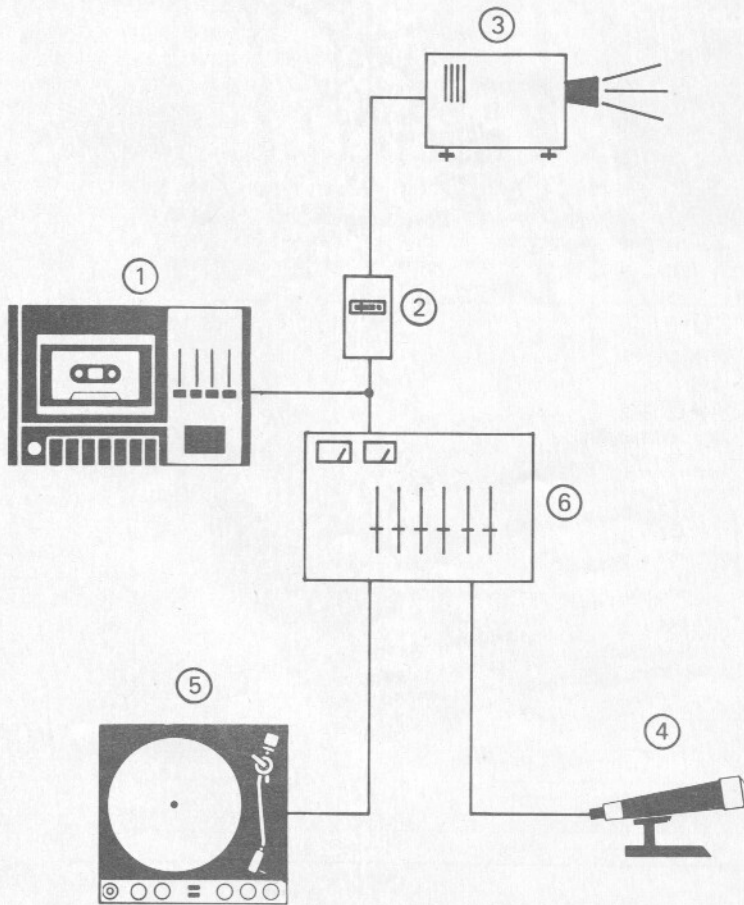

Figure 1 shows the simple circuit of the auto slide changer. In the absence of an audio signal at the input T1 and T2 are cut off. When a signal exceeding a predetermined level (set by P1) appears at the input then T1 will conduct on the positive peaks of the signal. The output from the emitter of T2 is integrated by C2 and T2. The collector voltage of T2 will be below the negative-going threshold of Schmitt trigger N1, so the output of N1 will be high. The input of N2 also floats high, its output is low and T3 is turned off, so the relay is not energised. If the input signal to T1 drops below the threshold then T1 turns off. If the

input voltage to T1 remains low then after a delay of about one second T2 will also turn off taking the input of N1 high. The output of N1 will go low and pull down the input of N2 via C3. The output of N2 will go high, turning on T3 and energising the relay. The relay contacts are connected to the remote change jack of the slide projector, so the slide will change. C3 will charge via R3 until the positive-going threshold of N2 is exceeded, when the output of N2 will go low ready for the sequence to repeat, and the relay will drop out. Diode D1 protects T1 against the back e.m.f. generated by the relay coil.

P1 provides a preset bias on the base of T1 and thus determines the threshold voltage at which T1 starts to conduct. By suitable adjustment of P1 it is possible to have background music underlying the commentary at a low level. P1 is adjusted so that T1 is not turned on with background music only present, but will turn on during the much louder speech passages. Figure 2 shows a typical setup for preparing a slide commentary. Recorded music and speech are mixed together and recorded onto tape. The slide changer is placed at the output of the mixer to check that the slide change does take place during pauses.

2



9743 - 1

3

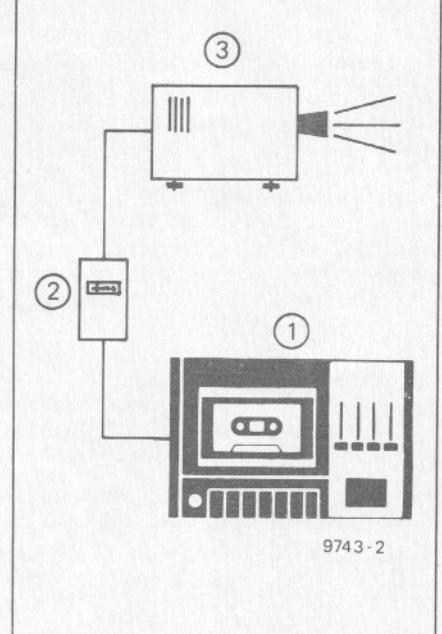

9743 - 2

Figure 1. Circuit of the auto slide changer.

Figure 2. Showing the setup for recording a commentary of speech and music to accompany a slide programme. When the output of the mixer drops below the preset level the slide will change.

Figure 3. For playback the slide changer is connected to the line output of the tape deck.

Notes. 1: Tape deck. 2: Auto slide changer. 3: Slide projector. 4: Microphone. 5: Record deck. 6: Audio mixer.

During the slide show the slide changer is connected to the line output of the cassette recorder (figure 3), or some other point in the system where the signal level fed to it is unaffected by volume or tone controls, since once the changer has been set up the signal level must not be altered.

To set up the slide changer during recording potentiometers P1 and P2 should first be set to their mid-position. P1 is then adjusted until the slide change will occur when a pause of about one second occurs in the commentary. P2 calibrates meter M1 to provide an indication of the threshold level. P2 should be adjusted so that M1 reads about a quarter scale when P1 is correctly set.

Figure 4. Printed circuit board and component layout for the auto slide changer (EPS 9743).

If the record and replay levels of the tape deck are correctly matched then no adjustment will be required when playing back the commentary. If, however, the playback level is different from the record level then it may be necessary to adjust P1 to set the correct threshold level for playback.

A p.c. board and component layout for the slide changer are shown in figure 4.

The unit requires a supply of 5 V at 18 mA (excluding the relay) which can easily be supplied by a simple zener stabiliser. A separate supply pin is provided for the relay, so that if a 5 V - 6 V type is not available some other voltage can be used, possibly derived from the unregulated input to the power supply. M

4

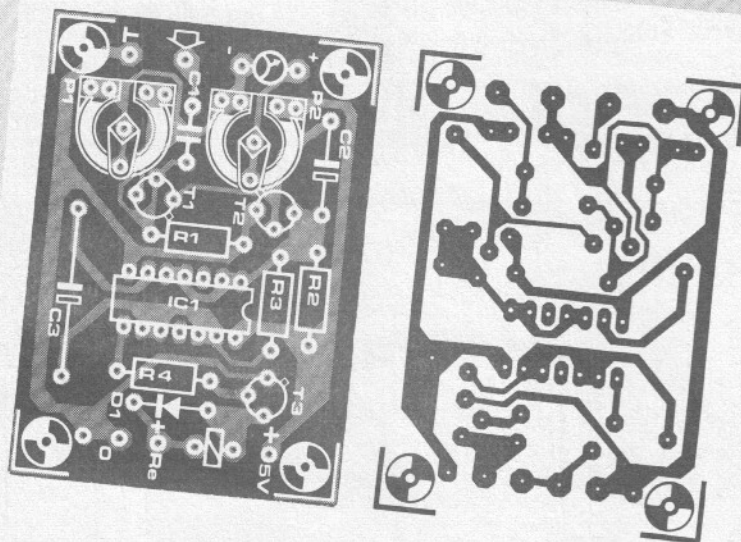

Parts List

Resistors:

R1 = 150 k
 R2 = 27 k
 R3 = 4k7
 R4 = 1 k
 P1 = 1 M preset
 P2 = 1 k preset

Capacitors:

C1 = 47 n
 C2 = 4 μ 7/10 V
 C3 = 220 μ /10 V

Semiconductors:

T1, T2 = BC547B or BC107B
 (or equivalent)
 T3 = BC141 or BC142
 D1 = DUS
 IC1 = 7413

Miscellaneous:

Relay 5 V - 6 V coil 68 Ω or greater, see text; normally open contact rated to suit current taken by projector remote change.

hinil drive for light sequencer

(H.P.Blomeyer)

Readers may remember that the 'Discolights' featured in Elektor September 1975 used TTL shift registers to drive triac switches. This is fine so long as great care is taken with layout and supply decoupling, otherwise noise from the triac switches can interfere with the sequencing of the TTL shift registers due to the poor noise immunity of the latter. The circuit described in this article shows an application of a new family of High Noise Immunity Logic (HINIL) from Siemens. This has the advantage (in this type of application) that the logic thresholds are much higher. The switching speed is also lower than that of TTL, so the circuits are much less likely to be affected by short transients.

The circuit of the light sequencer is given in figure 1. Clock pulses are provided by an oscillator based on a Schmitt trigger, which readers will no doubt have encountered before in TTL circuits. P1 controls its frequency, ST2 buffers the output of the oscillator. Since the HINIL shift registers can sink more current than they can supply the circuit is arranged to operate from a negative supply voltage so that negative-going pulses can be used to trigger the triac switches.

It will be noted that the 0 V rail of the sequencer is connected to the neutral side of the triac dimmer shown at the top left corner of the circuit. Thus when an output of the shift register is high

(i.e. at 0 V) the triac has zero gate voltage and the lamp is extinguished. When an output of the shift register goes low (i.e. down to -12V) the triac receives a negative gate voltage and the lamp lights on negative half-cycles of the supply waveform. Note that since the triac is controlled only on negative half-cycles the lamp receives only half power and is thus not operating at full brightness. This should not really be a disadvantage for the intended application.

The operation of the sequencer is as follows: at the start of a sequence the outputs of all the shift registers are high and all lamps are extinguished. The serial input of IC1 is tied to -12V

(i.e. logic 0) so on each clock pulse a '0' will be loaded into the serial input. The four shift registers are connected in cascade and as the 0's shift through the lamps will light in turn until all are illuminated.

On the clock pulse after the last lamp is illuminated pin 6 of IC4 will go low, causing the output of N4 to go high. The output of N4 is connected to the 'parallel load' inputs of IC1 to IC4, so the data on these parallel inputs will appear on the outputs. Since the parallel inputs are all connected to 0 V they are at logic 1 so 1's appear on all the outputs and the lamps extinguish. The whole cycle then repeats. At any time the sequence may be reset manually by S1, which inhibits the clock generator and makes the output of N4 go high.

Buffer stages N1 to N3 are included on outputs pin 12 of IC1 to IC3 as otherwise these outputs would have to drive both a triac and the serial input of the next shift register, which would exceed their fanout.

Extensions

This, of course, is simply one example of what can be done. It is quite possible to extend the circuit to control many more lamps by increasing the number of shift registers. The only point to remember is that the fanout of N4 is limited to 30, and the input loading of the parallel load input of an FZJ161 is 4, so N4 will drive only 7 shift registers. This can be overcome by connecting additional gates in parallel with N4. Other sequences can also be devised, limited only by the ingenuity of the constructor. Some useful suggestions are given in the previously mentioned article 'Discolights'.

Warning

Since the positive side of the sequencer power supply is connected to mains neutral the entire circuit should be treated as having mains voltages on it. The unit should be mounted in an insulated box, or if in a metal box should be isolated from the box and the box earthed. P1 should have an insulated spindle and none of the metal parts of P1 should be accessible.

Final note

The Siemens triac type TXC 01F40 may not be readily available. Any other reasonably sensitive triac may be used, however.

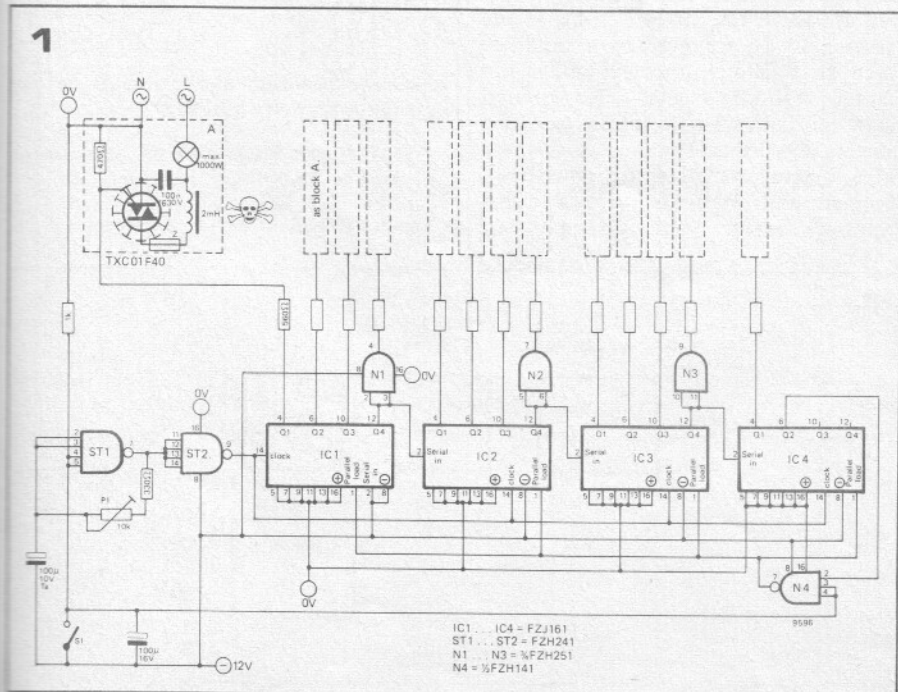

Figure 1. Circuit of the Light Sequencer. Each shift register output drives a triac switch (one only shown).

Variometer tuner

(part 2)

Having dealt with the construction of a mono FM receiver using the Variometer front-end, the second part of this article describes the design of a stereo tuner. This tuner uses a double conversion i.f. and PLL demodulator, and offers performance equal to the best commercially available tuners.

As mentioned in the first part of this article, to provide a satisfactory signal-to-noise ratio in stereo, a PLL demodulator must operate at a low i.f. This ensures that the ratio of the VCO frequency deviation to VCO free-running frequency is as high as possible, so that phase noise in the VCO does not degrade the s/n ratio.

Since the i.f. output of the variometer front-end is at 10.7 MHz this means that a second frequency conversion must be performed to convert this to a much lower intermediate frequency such as 450 kHz, hence the term 'double-conversion'.

There are, on the market, double conversion PLL FM i.f. systems integrated into a single IC. However, it was felt that considerably superior performance could be obtained using a PLL made from discrete components (though admittedly containing one IC) such as the OTA PLL used in the mono receiver described last month. This also means that any readers who have built the mono receiver can, if they wish, extend it to a stereo version without wasting the OTA PLL already built.

Block Diagram

As the simplified block diagram of figure 1 shows, the mono tuner is converted to the stereo version simply by inserting the new i.f. converter and 450 kHz i.f. amplifier between the Vario tuner and the existing OTA PLL, and by adding a birdy filter and stereo-decoder to the PLL output. The OTA PLL must, of course be slightly modified to operate at 450 kHz.

Figure 2 shows that this 'simple' circuit is somewhat more complex when examined in more detail. The i.f. converter is the section enclosed by a dotted line. The 10.7 MHz output of the Vario front-end is first converted down to 450 kHz by mixing with a second local oscillator signal at either 10.25 or 11.15 MHz. Either of these frequencies (low or high frequency heterodyning) will give a difference frequency at the mixer output of 450 kHz.

Of course, other unwanted products also appear at the mixer output, so the mixer must be followed by a bandpass filter that allows through only the wanted 450 kHz signal. The filtered signal is then fed to three cascaded limiting amplifiers. The outputs of these three stages are detected (rectified), summed and used to drive a signal strength meter. Its principle of

operation is as follows: at low signal levels none of the three amplifiers will be limited. An increase in signal will cause an increase in each amplifier output, which will cause an increased reading on the meter. Most of the drive to the meter will, of course, be provided by the third stage, since this has the greatest output. Once the third stage has limited it will make no further contribution to an increase in the meter reading, and most of the incremental meter drive will be provided by the second stage. This in turn will limit, so that only the first stage will be contributing to an increase in the meter reading with increased signal strength.

The meter will thus start off at low signal levels by giving a large increase in the reading for a small increase in signal strength. Once the third stage has limited it will require a much larger increase in signal strength to give the same increase in meter reading and so on. In other words the sensitivity of the meter will reduce as the signal level increases, that is to say it will have an approximately logarithmic response. This is an ideal type of response for a signal strength meter, which may have to deal with a change in signal strength of around 100 dB (100,000 times), since it allows small signals to be seen without overloading on large signals.

The meter drive circuit also provides the drive to a muting circuit that switches off the output signal from the OTA PLL when the signal level falls below a certain value, which can be varied by means of the 'mute level' potentiometer. This means that interstation noise is not heard when tuning between stations.

The output of the third limiting amplifier is fed to the OTA PLL, which provides further gain and also demodulates the signal in a similar manner to

Figure 1. Simplified block diagram of the double conversion stereo tuner.

Figure 2. Block diagram of the stereo tuner showing details of the i.f. converter.

Figure 3. Circuit of the i.f. converter.

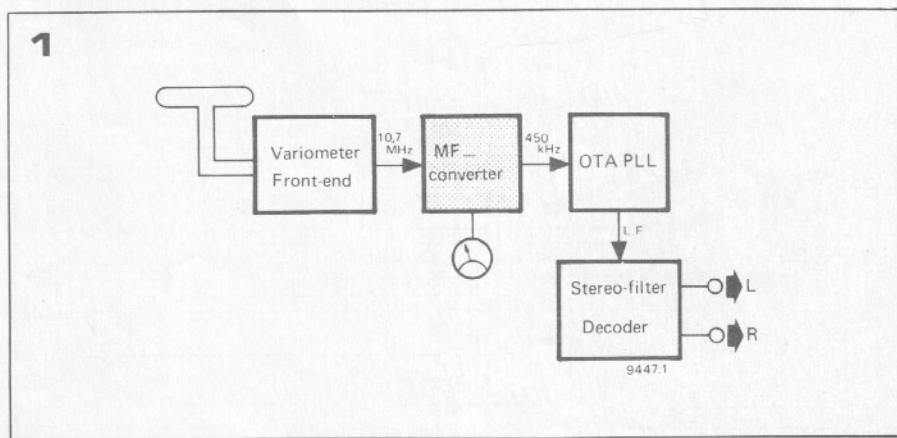

2

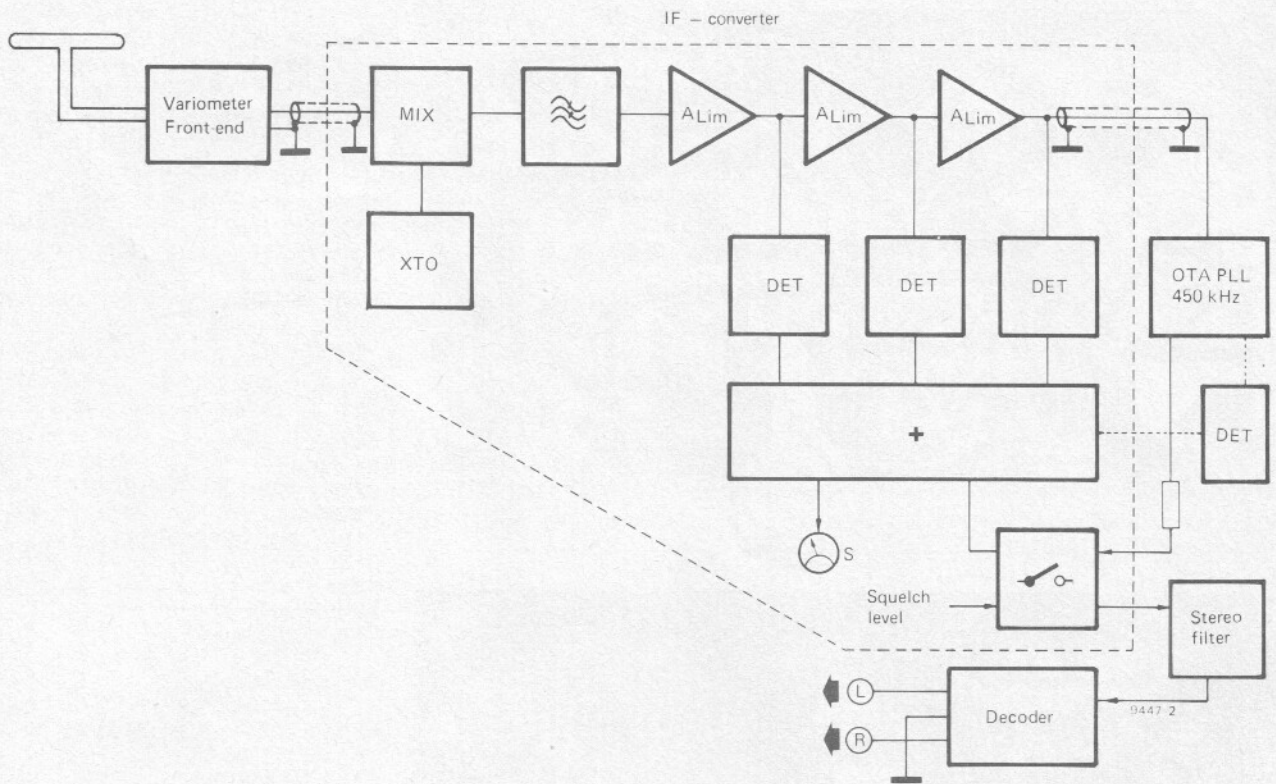

3

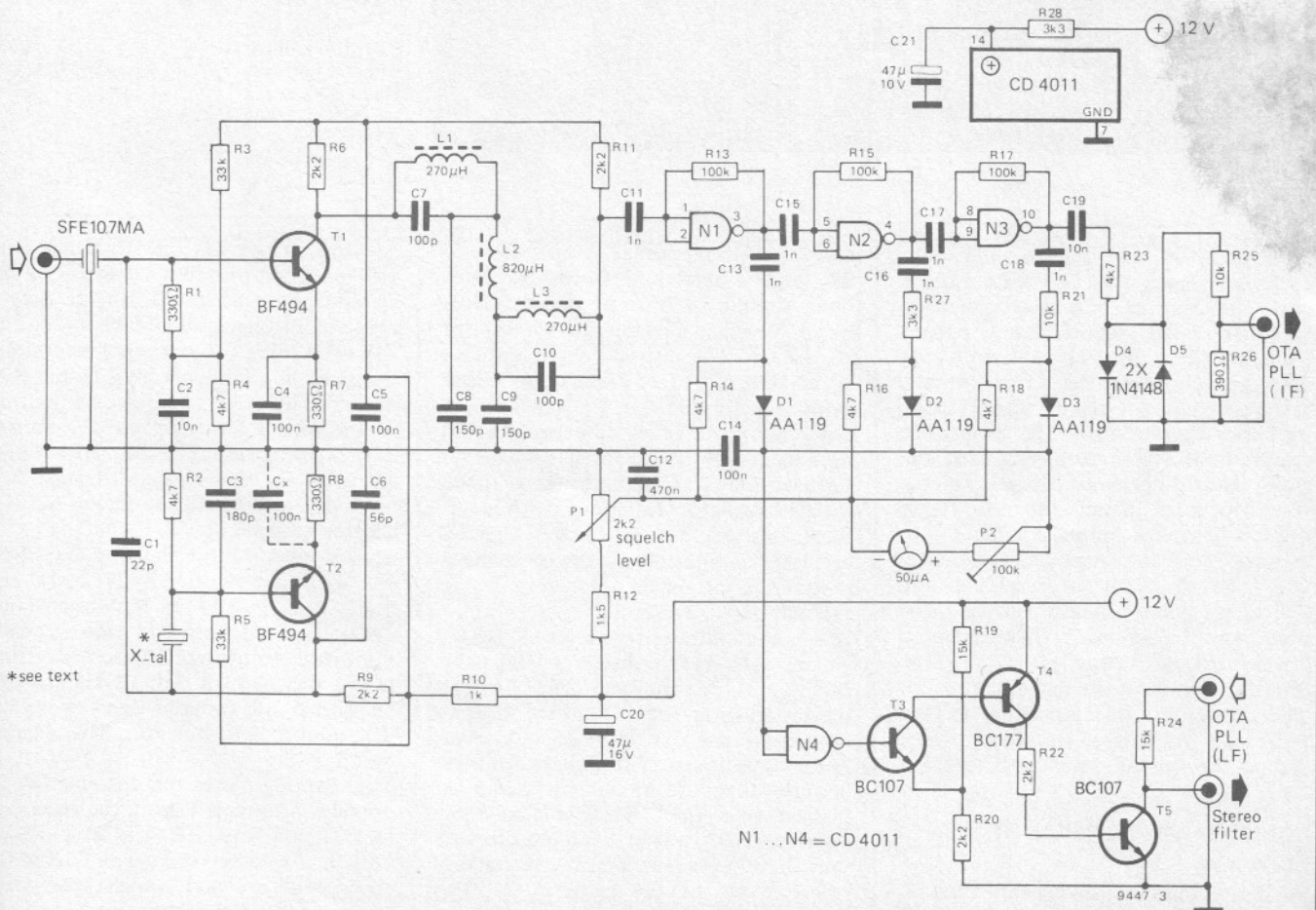

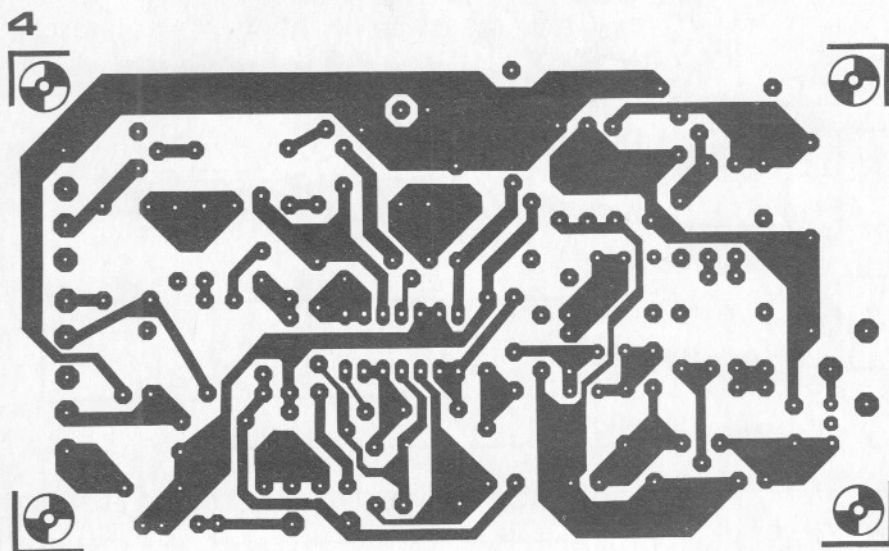

Parts list for figures 3 and 4.

Resistors:

R1,R7,R8 = 330 Ω
 R2,R4,R14,R16,R18,R23 = 4k7
 R3,R5 = 33 k
 R6,R9,R11,R20,R22 = 2k2
 R10 = 1 k
 R12 = 1k5
 R13,R15,R17 = 100 k
 R19,R24 = 15 k
 R21,R25 = 10 k
 R26 = 390 Ω
 R27,R28 = 3k3

Capacitors:

C1 = 22 p
 C2,C19 = 10 n
 C3 = 180 p
 C4,C5,C14 = 100 n
 C6 = 56 p
 C7,C10 = 100 p
 C8,C9 = 150 p
 C11,C13,C15,C16,C17,C18 = 1 n
 C12 = 470 n
 C20 = 47 μ /16 V
 C21 = 47 μ /10 V
 C_x = 100 n (see text)

Semiconductors:

T1,T2 = BF 494
 T3,T5 = BC 107, BC 547
 T4 = BC 177, BC 557
 N1 . . . N4 = CD 4011
 D1,D2,D3 = AA 119
 D4,D5 = 1N4148

Miscellaneous:

L1,L3 = 270 μ H R.F. choke
 L2 = 820 μ H R.F. choke
 P1 = 2k2 lin. pot.
 P2 = 100 k lin. preset
 SFE 10.7 MA or CFSA 10.7 ceramic filter
 10.25 MHz or
 11.15 MHz XTAL \pm 25 kHz
 50 μ A meter

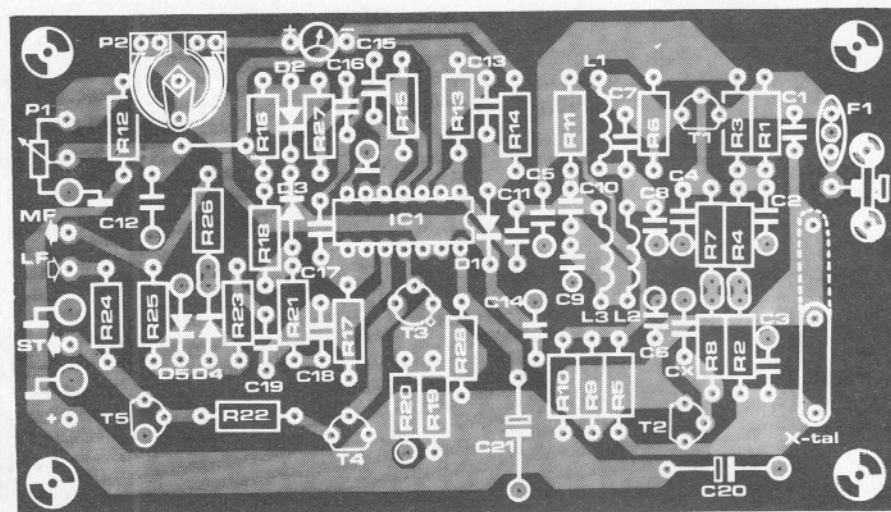

that described last month, the only difference being that the OTA PLL is now operating at 450 kHz instead of 10.7 MHz. The demodulated output from the PLL is fed back into the muting section of the i.f. converter, then out again into a 'birdy' filter. Because of the large i.f. bandwidth required for stereo reception, and the close channel spacing (200 kHz) in the FM broadcast band, the i.f. stages cannot be relied upon completely to suppress adjacent channel interference, which is apparent as warbling and chirruping noises - hence 'birdies'. The only way to suppress these is by a lowpass filter, cutting off at 55 kHz, after the output of the demodulator.

The output of the birdy filter is then fed to the stereo-decoder, which utilises the well-known 1310 IC.

Complete Circuit of the i.f. Converter

Figure 3 shows the full circuit of the i.f. converter. The output of the Vario front-end is fed to a ceramic filter, which provides some 10.7 MHz selec-

tivity. The mixer stage is built around T1, while a crystal controlled oscillator built around T2 provides the oscillator signal, which is injected into the base of T1 via C1. The crystal can be either a 10.25 MHz or 11.15 MHz type, either being equally suitable. Capacitor C_x is not required in every case, and should be added only if the oscillator fails to start without it. It should not be added if the oscillator functions without it since this could lead to too high an oscillator amplitude with consequent production of unwanted harmonics in the oscillator waveform.

The mixer output is filtered by L1-L3 and C7-C10 before being fed into the first limiting amplifier. The limiting stages are somewhat unusual in that they make use of CMOS logic gates as linear amplifiers. These were chosen because they are extremely cheap, if biased into their linear region they make perfectly adequate amplifiers, and they have excellent limiting characteristics. Three of the gates in a 4011 package are used as limiting amplifiers, the fourth being used in the muting circuit.

The output of the third limiting stage (N3) is taken out via C19 and R23 and clamped by D4 and D5. Since only a small input signal should be applied to the OTA PLL for optimum operation, the signal is attenuated by R25 and R26 before feeding to the PLL. The output of the PLL is fed back into the muting switch, comprising T5 and R24. When T4 is off the signal passes through R24 unhindered. When T5 is on the signal is shorted to ground.

The outputs of the limiting amplifiers N1 to N3 are rectified by D1 to D3 and used to charge C14. In the absence of a signal the voltage on C14 will be below the threshold level of N4, so the output of N4 will be high. T3, T4 and T5 will be turned on and the signal from the PLL output will be shorted to ground by T5.

The muting level potentiometer P1 provides a variable bias on the anodes of D1, D2 and D3 via R14, R16 and R18. This puts a preset voltage on C14 in the absence of a signal, which determines how much additional signal will be required from the limiting amplifiers before the threshold of N4 is exceeded

and T3, T4 and T5 will turn off, allowing the signal to pass. For example, with no preset voltage on C14 the output signal from N3 would have to equal the threshold level of N4 plus the forward voltage of D3 before the muting switch would open. With the voltage on C14 preset to just below the threshold of N4, on the other hand, very little signal would be required to switch N4. Note that with P1 turned fully clockwise (max. muting level) the slider is grounded.

The signal strength meter is also connected to C14 via P2, which adjusts its full-scale deflection. However, if the negative end of the meter were connected to ground it would register the preset bias on C14, even in the absence of a signal. To avoid this the negative end of the meter is taken to the slider of P1, so that in the absence of a signal the positive end of the meter is at

more or less the same potential as the negative end (except for the forward voltage of D1-D3). The meter reading will thus be almost zero, in fact very slightly negative, in the absence of a signal.

Printed Circuit

A printed circuit board and component layout for the i.f. converter are given in figure 4 and require little comment. The only point is that 10.25 and 11.15 MHz crystals are likely to be relatively expensive, and it may be worth trying 30.75 MHz \pm 75 kHz or 33.45 MHz \pm 75 kHz third overtone crystals, which are available fairly cheaply on the surplus market.

OTA PLL

The modified circuit of the OTA PLL is given in figure 5, and the printed circuit board and component layout are given

in figure 6. The following changes for operation at 450 kHz should be noted:
 R1, R24 omitted
 P1, now 2k2 or 2k5.
 P2, omitted. Can be left in circuit if already built.
 C11, now 2n7.
 C14, now 82 p.
 C15, omitted.

Figure 4. Printed circuit board and component layout for the i.f. converter (EPS 9447-2).

Figure 5. Modified circuit of the OTA PLL.

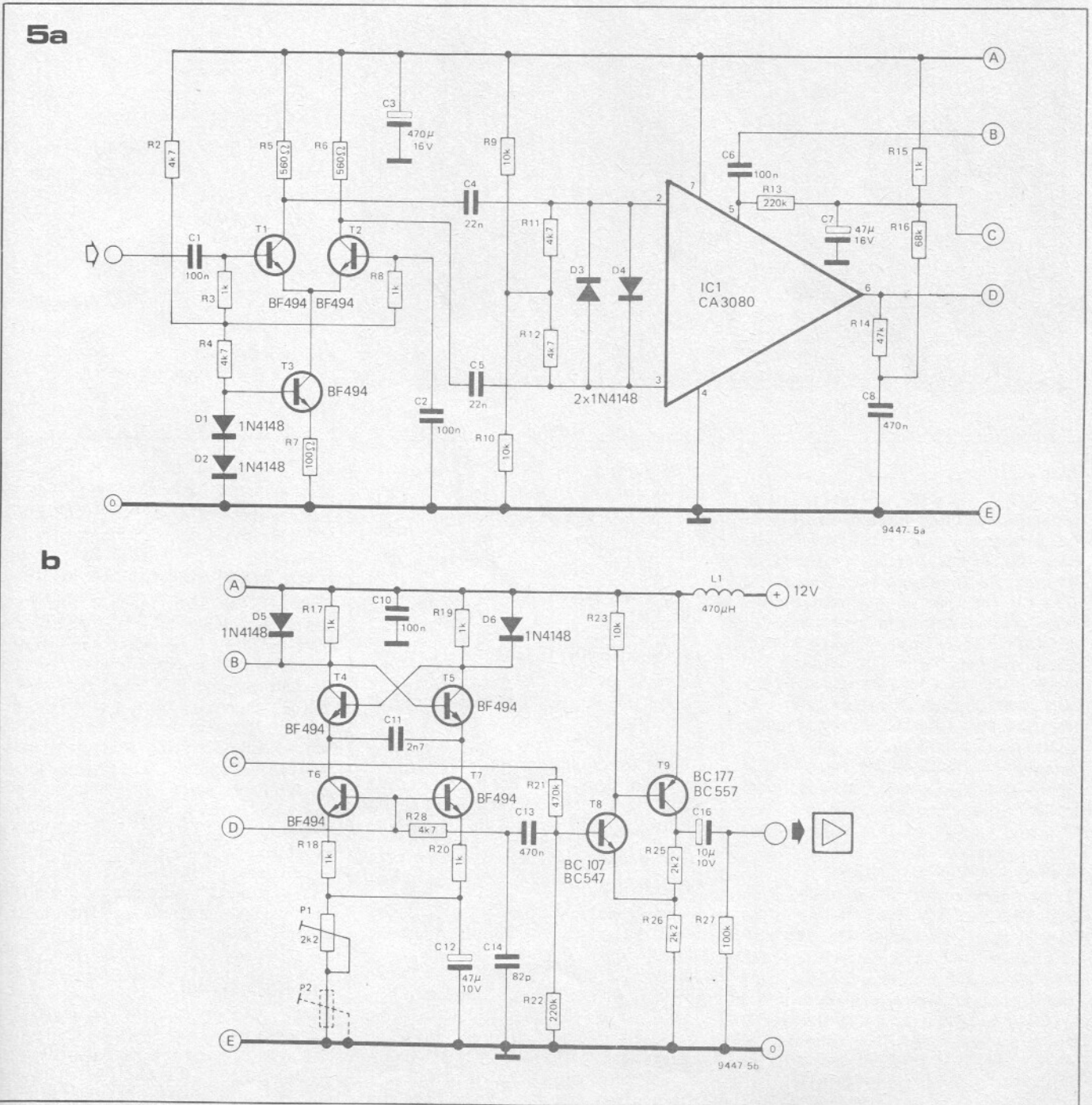

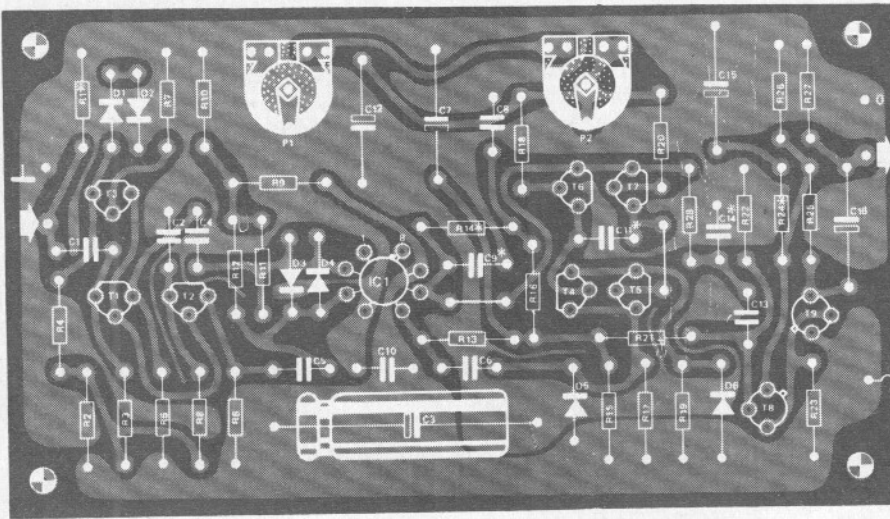
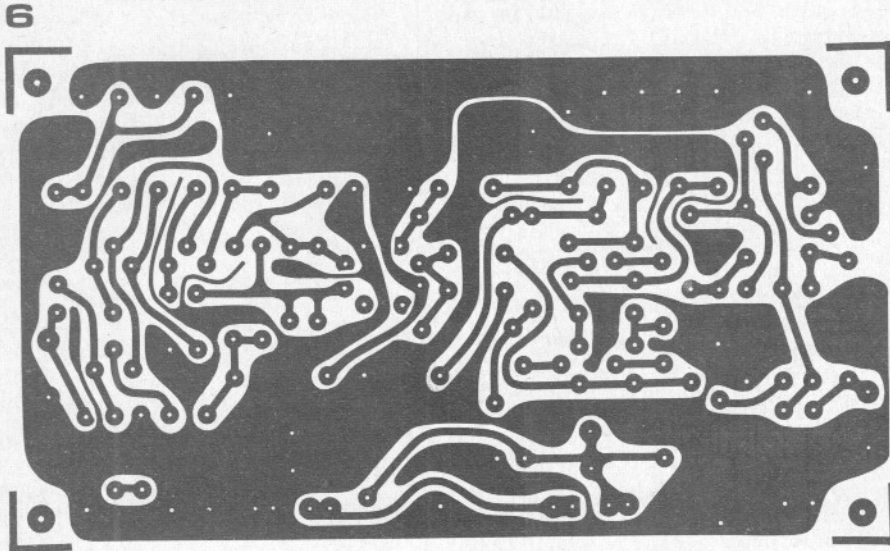

Parts list for figures 5 and 6.

Resistors:

R1, R24 = omitted
 R2, R4, R11, R12, R28 = 4k7
 R3, R8, R15, R17, R18, R19, R20 = 1 k
 R5, R6 = 560 Ω
 R7 = 100 Ω
 R9, R10, R23 = 10 k
 R13, R22 = 220 k
 R14 = 47 k
 R16 = 68 k
 R21 = 470 k
 R25, R26 = 2k2
 R27 = 100 k
 P1 = 2k2 (2k5)
 P2 = omitted (wire link)

Capacitors:

C1, C2, C6, C10 = 100 n
 C3 = 470 μ /16 V
 C4, C5 = 22 n
 C7 = 47 μ /16 V
 C8, C13 = 470 n
 C9, C15 = omitted
 C11 = 2n7
 C12 = 47 μ /10 V
 C14 = 82 p
 C16 = 10 μ /10 V

Semiconductors:

T1 ... T7 = BF 494
 T8 = BC 107, BC 547
 T9 = BC 177, BC 557
 D1 ... D6 = 1N4148
 IC1 = CA 3080

Miscellaneous:

L1 = R.F. choke 470 μ H

Birdy Filter

Established readers of Elektor may recognise the birdy filter of figure 7a as being the same as that used in the 'Feedback PLL Receiver' featured in Elektor No 9. The only difference is that the function of the input resistor R9 is taken over by the collector resistor of T5, R24 on the i.f. converter board. C2 can be used to improve the stereo separation by adjusting the filter to give zero phase shift at 38 kHz. This can be done using a signal generator and dual beam scope, or if this is not available by tuning in to Aunty BBC's stereo test transmissions and adjusting by ear.

Stereo Decoder

With the exception of the 7400, 4011 and 741 the MC1310 must surely be one of most overworked IC's, and here it is again used in the stereo decoder. The circuit has been described so many times that an operational description will not be given here, just the setting up procedure. The best method of setting up, if a frequency counter or calibrated oscilloscope is available, is to set the frequency of the VCO to 76 kHz

by monitoring the 19 kHz (!) output at pin 10 and adjusting P1. Otherwise tune to a strong station transmitting in stereo and adjust P1 until LED D1 lights (S1 must be open). Turn P1 left and right until it extinguishes, then set it to about the middle of the range over which it is lit.

Printed Circuit Board

Figure 8 gives a p.c. board and component layout for the birdy filter and stereo decoder. To allow for the possibility of using this p.c. board with alternative i.f. systems a position for R9 has been included on the board. For use with the double conversion PLL this position should be occupied by a wire link.

Power Supply

A simple stabilized supply for the mono tuner was given last month. Since the stereo tuner operates from a 12 V supply this must be modified as shown in figure 9. The current consumption of the tuner is less than 100 mA, so the stabiliser should be fed from an unregulated 17 V (approx) DC supply capable of providing this current. Alternatively an IC voltage regulator

such as the TBA625B or similar 12 V type could be used. Another alternative is the power supply used in the 'local' radio described in Elektor 22.

Pilot Tone Filter

The 19 kHz pilot tone of the 1310 stereo decoder may not be sufficiently well suppressed for some applications. Those with supersensitive 'earholes' may be able to hear this tone, and what is worse, when used with a tape recorder the 38 kHz subcarrier may beat with the bias oscillator, giving some very nasty noises. Fortunately, Toko manufacture a filter designed to remove these offending signals, which has two deep notches at 19 kHz and 38 kHz, combined with a gradual rolloff at high frequencies. It does all this with hardly any detriment to the bandwidth of the audio signal, as can be seen from table 1 (only 1.2 dB down at 15 kHz).

Wiring Diagram

Figure 10 shows a complete interwiring diagram of the stereo variometer tuner. To avoid any problems this should be adhered to, though the physical disposition of the boards may be varied

Figure 6. Component layout and p.c. board for the OTA PLL (EPS 6029).

Figure 7a. The birdy filter.

Figure 7b. Circuit of the stereo decoder.

Table 1. Data and pin connections of the BLR3107 pilot tone filter.

Table 1

BLR3107 Parameters

Attenuation at:	15 kHz	1.2 dB max.
	19 kHz	26 dB min.
	38 kHz	50 dB min.
Input impedance		3 k
Output impedance		4k7
Insertion loss at 1 kHz		1dB

9447 T1

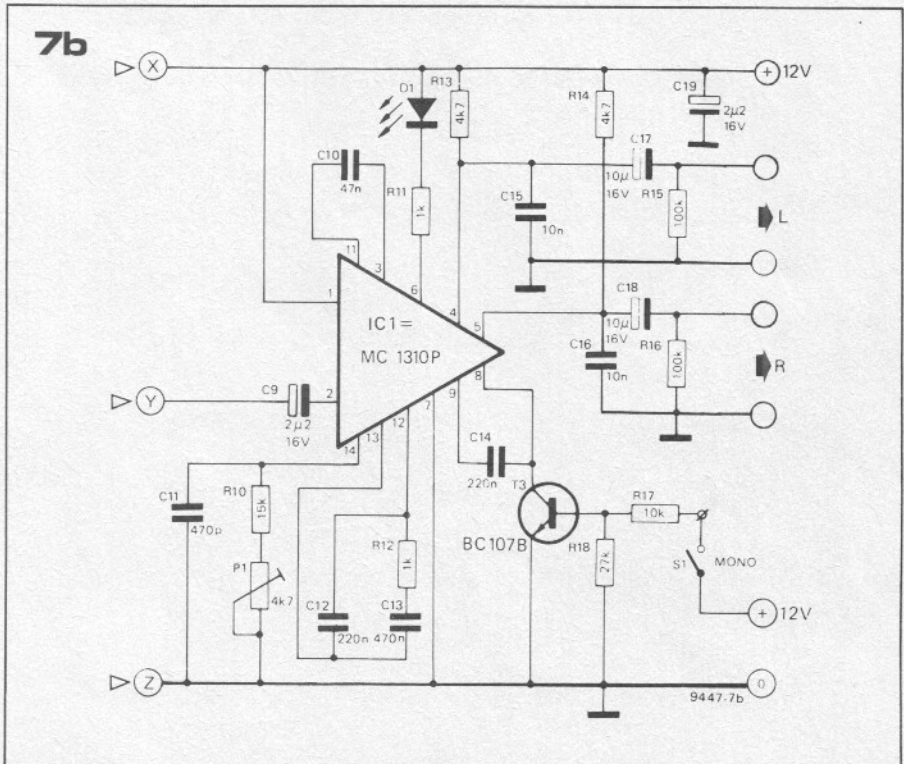
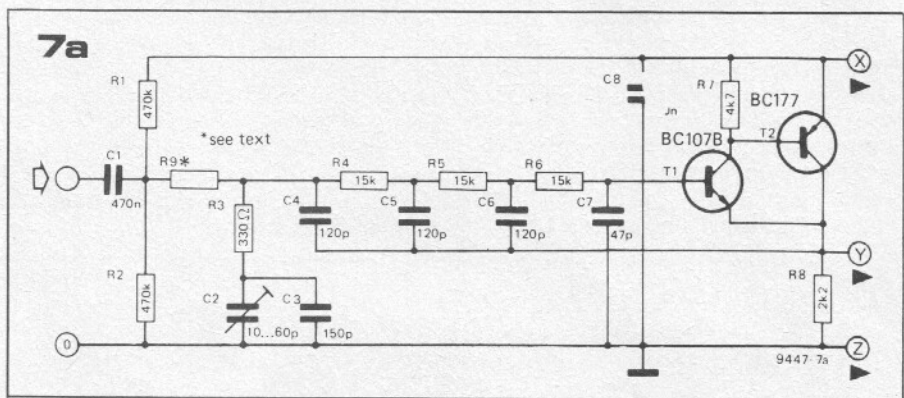

to suit the chassis used. Connections between the aerial socket and front-end, front-end and i.f. converter, i.f. converter and OTA PLL should be made using 75 Ω coax cable, preferably miniature for ease of bending round corners etc. All low frequency signal connections, including the connection to the muting level pot., should be made using screened audio cable. The i.f. converter should preferably be screened from the other units by mounting in a box of steel or tinfoil.

Tuning Scale

Figure 11 shows a suggested tuning scale. If a 45 mm diameter drive drum is used on the Variometer spindle then this scale is full size. For larger or smaller diameter drive drums the drawing must be scaled up or down to suit.

Alignment procedure

For those who wish to build the stereo tuner 'from scratch' without first building the mono version the complete alignment procedure (including that for the front-end) is given here.

1. Connect the tuner input to a good aerial system and the left and right

audio outputs to the tuner or auxiliary input of a stereo amplifier.

2. Turn the muting level control fully anti-clockwise so that the interstation noise is un-muted.

3. Set P1 in the OTA PLL to mid-position.

4. Set the core of L6 in the front-end to give maximum noise.

5. Set the tracking of the front-end by adjusting the core of L5 to tune to 87 MHz with the pointer at the left-hand end of the tuning scale, and by adjusting C21 to tune to 104 MHz with the pointer at the right-hand end of the tuning scale. If no stations can be received at these frequencies then find the two stations which are furthest apart on the tuning scale and adjust L5 and C21 to set them to the correct points on the scale. L5 and C21 interact so several successive adjustments may have to be made.

6. Tune to a (preferably weak) transmission around 90 MHz*, and adjust the cores of L3 and L4 in the front-end for maximum signal and/or minimum noise.

7. If possible tune to a weak transmission around 100 MHz and adjust C5 and C8 for minimum noise.

8. Repeat 5, 6 and 7 until no further

improvement can be obtained. Note that a special trimming tool is required to reach L4. If such a tool is not available, the core of L3 can be removed and L4, L5, C8 and C21 are trimmed. Then the core of L3 is inserted and L3 and C5 are adjusted.

9. Tune to a very weak (noisy) transmission and adjust the core of L6, in the front end to obtain minimum noise and/or maximum signal.

10. Adjust the free-running frequency of the VCO in the OTA PLL until the capture range of the PLL is symmetrical about the i.f. frequency. To do this turn P1 first clockwise, then anti-clockwise until the signal disappears, then set P1 to the middle of this range.

11. Tune to a stereo transmission and set P1 in the stereo decoder so that the LED D1 lights. Find the range of settings of P1 over which D1 will light then set P1 to the middle of that range.

* If an FM signal generator is available then the alignment procedure can be carried out using it.

A strong broadcast transmission can be turned into a 'weak' one by using an aerial attenuator or by substituting a short piece of wire for the good aerial system.

12. Using the BBC stereo test transmissions, of which details are available from the BBC, adjust C2 in the birdy filter to obtain maximum channel separation either by ear or using a millivoltmeter or oscilloscope connected to the amplifier output. When a signal is present only on the right channel C2 should be adjusted for minimum signal

on the left channel and vice versa.

13. Tune to the strongest signal in the FM band and adjust P2 in the i.f. converter to give full-scale deflection of the signal strength meter.

14. Finally, if desired, insert a 10-60 p trimmer in the position marked C_x in the front-end and trim for minimum noise on weak stations.

Final Notes

The output from the 1310 stereo decoder is nominally 100 mV when connected to the output of the OTA PLL. This output level was chosen to obtain minimum distortion from the 1310, but it may be a little on the low side for some amplifiers. Those who require a higher output and are willing

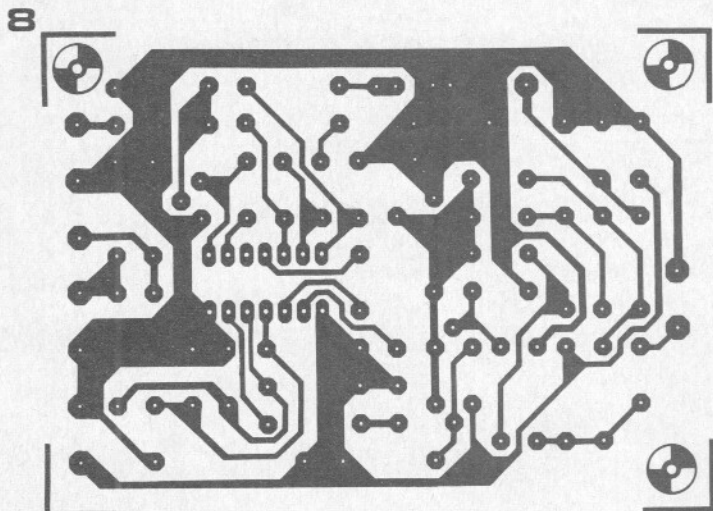

Parts list for figures 7 and 8.

Resistors:

- R1,R2 = 470 k
- R3 = 330 Ω
- R4,R5,R6,R10 = 15 k
- R7,R13,R14 = 4k7
- R8 = 2k2
- R9 = see text
- R11,R12 = 1 k
- R15,R16 = 100 k
- R17 = 10 k
- R18 = 27 k

Capacitors:

- C1,C13 = 470 n
- C2 = trimmer 10 . . . 60 p
- C3 = 150 p
- C4,C5,C6 = 120 p
- C7 = 47 p
- C8 = 100 n
- C9 = 2μ2/16 V
- C10 = 47 n
- C11 = 470 p
- C12,C14 = 220 n
- C15,C16 = 10 n
- C17,C18 = 10 μ/16 V
- C19 = 47 μ/16 V

Semiconductors:

- T1,T3 = BC 107 B, BC 547 B
- T2 = BC 177, BC 557
- D1 = LED
- IC1 = MC 1310 P

Miscellaneous:

- P1 = 4k7 lin. pot
- S1 = SPST switch

9

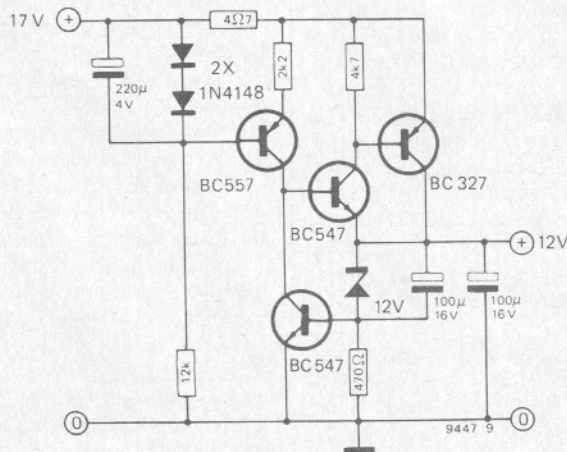
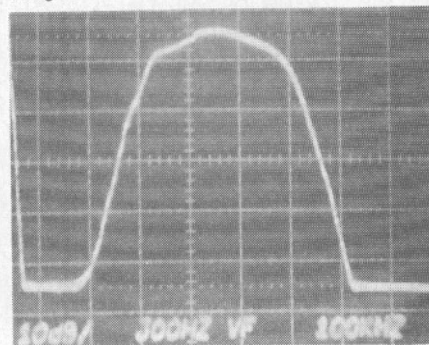

Figure 8. Component layout and p.c. board for the birdy filter and stereo decoder (EPS 9447-3).

Figure 9. The power supply used in the mono tuner, modified for use with the stereo tuner.

Figure 10. Complete wiring diagram of the stereo tuner. Note that the power supply shown is that used in the 'local' radio (Elektor 20) which is equally suitable for this design.



10

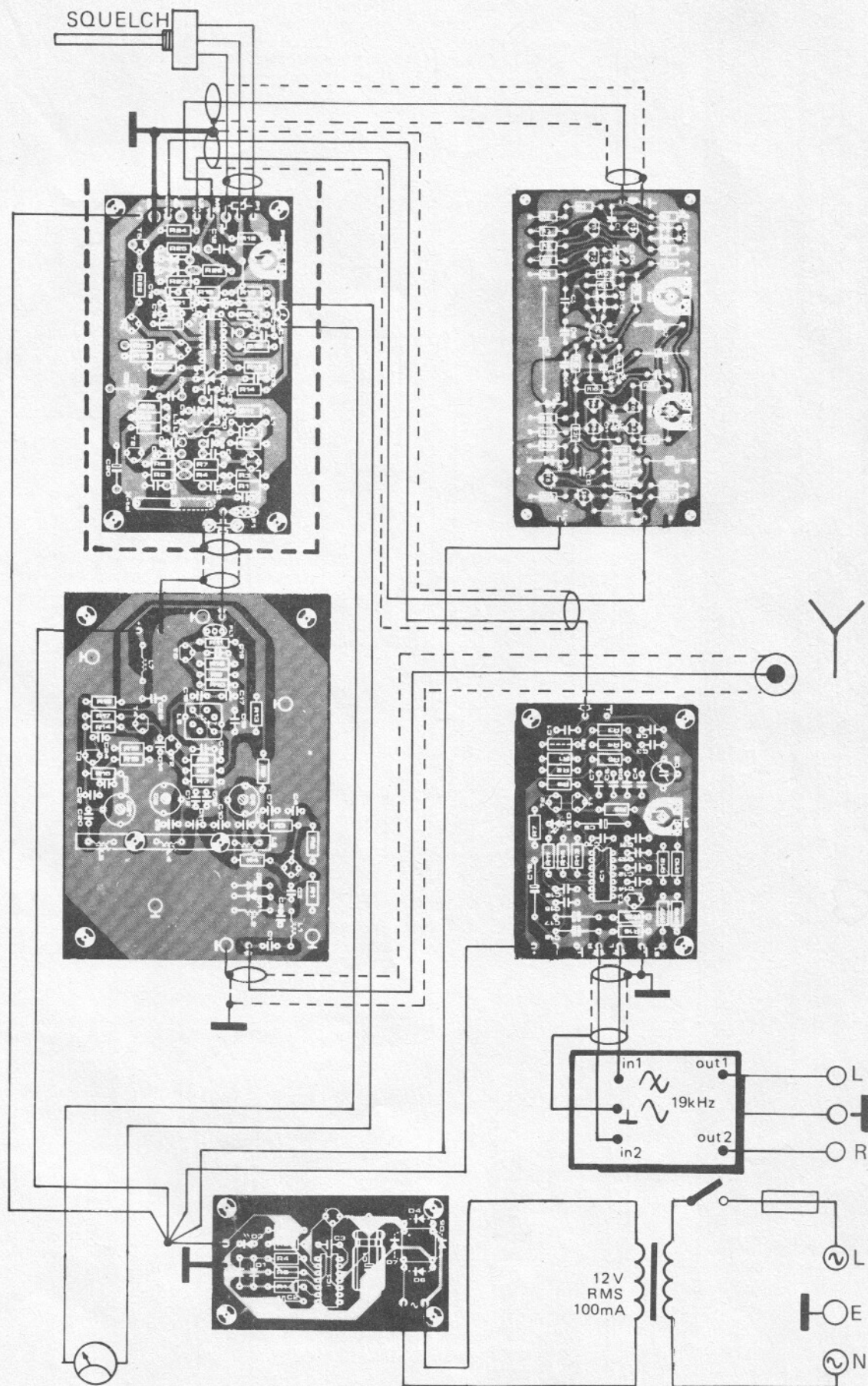
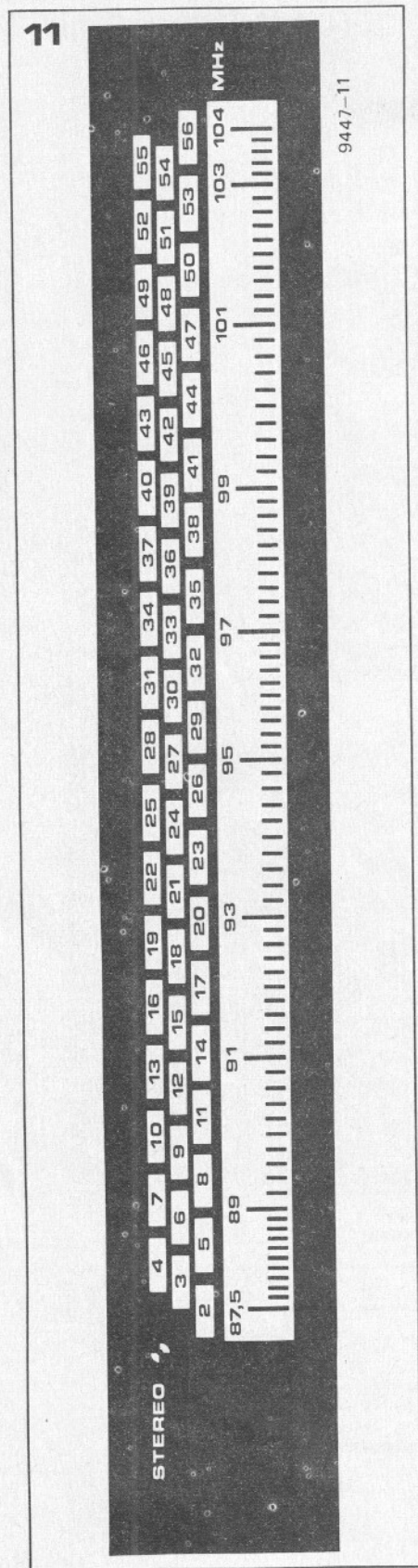

Figure 11. Suggested tuning scale layout.



11

9447-11

to tolerate a slight increase in distortion can increase the decoder output by feeding in a larger signal from the PLL. This is achieved by increasing the gain of the PLL output stage T8/T9. To do this R24 and C15 are reinstated in the circuit. C15 should be 100 μ 6V and R24 can be between 470 Ω and 2k2, determined experimentally. Note that the load impedance at the output of the decoder should be not less than 22 k. **K**

albar mk II = a bfs...

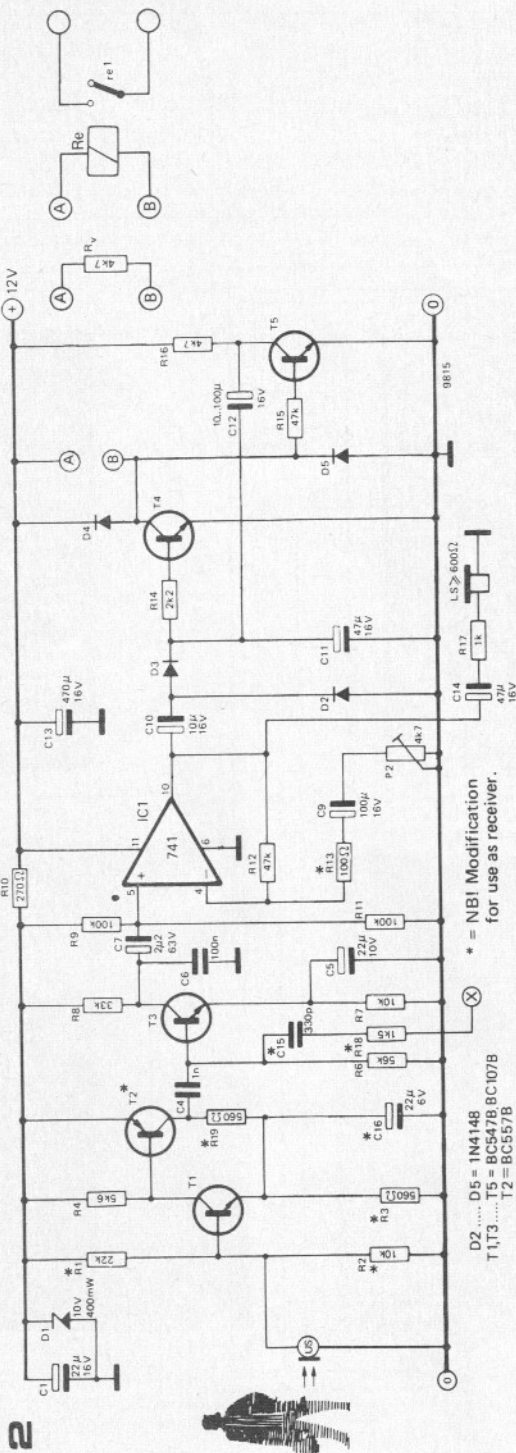

2

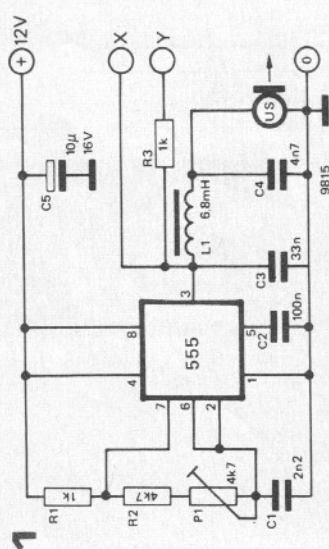

1

The ultrasonic movement detector 'Albar', originally published in E19 (November 1976), has proved a great success. Unfortunately, in some cases the joy was short-lived: over 10% of the units constructed would only work over a very short range. Lab tests have shown that the root of the problem is the ultrasonic transducer itself. These transducers are quite delicate — they do not take kindly to being dropped on a stone floor, for instance — and furthermore their actual character-

istics are often very different from the 'typical specs'. Several alternative approaches to the problem have been tried, with varying degrees of sophistication and varying degrees of success. Finally, we settled on a Brute Force Solution: use two transducers, one as transmitter and one as receiver. This is more expensive than the single-transducer version, of course, but it has proved 100% reliable in all lab tests so far — with a large number of different transducers.

The original Albar circuit is modified slightly to work as a receiver (figure 2) and a transmitter is added (figure 1). The modifications to the original circuit can be carried out on the existing board, but a new board is now being prepared that can be used for both the old and the new circuit. This will be described in detail next month. For those readers who can't wait to try it out, the main points to watch are that the transmitter and receiver are inter-connected at point 'X' and have a

common supply; that the transducers are mounted in the same box, facing out in the same direction, and that the circuit may become over-sensitive if there are large reflecting surfaces in the immediate vicinity of the transducers. Connection 'Y' is not used yet. P1 in the transmitter sets the optimum transmitting frequency: the easiest way is to use the earpiece and set P1 for maximum doppler shift with a moving object in front of the transducers. P2 is a sensitivity control which can be set according to personal taste. One final tip: in some cases one transducer is better than the other, so it is worth while interchanging them to see which one is best for the receiver. **K**



Availability of polyester capacitors

Compstock is now stocking a full range of Erie radial-lead polyester metallised film capacitors, series 51016.

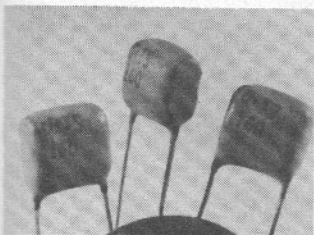

This series is manufactured in four ranges which are designed to handle working voltage ratings of 160 volts D.C., 250 volts D.C., 400 volts D.C. and 630 volts D.C. They have a capacitance range of 0.010 to 10.0 microfarads and are stocked in ± 10 percent and ± 20 percent tolerance. The capacitors will operate over the temperature range of -40 to $+85^{\circ}\text{C}$ and have a dissipation factor of less than 0.002 when measured at 1 kHz at 25°C . Solderability is to BS9076 and the capacitors are dipped in a resin-based solvent resistant coating. The capacitors are available either with standard straight leads or to order with leads preformed.

Compstock Electronics Ltd.,
42/44 Bowlers Croft,
Basildon, Essex

(433 M)

Illuminated contactless pushbuttons

Recently announced by EES Ltd. is a new range of illuminated pushbuttons incorporating a Hall effect chip from which a switch output via two open collector transistors operating

either in phase or in antiphase is derived. Capable of operating between 4.5 volts and 27 volts and with rise and fall switching times of less than $0.5 \mu\text{sec}$, the outputs from these switches enable them to be directly interfaced with all data logic systems.

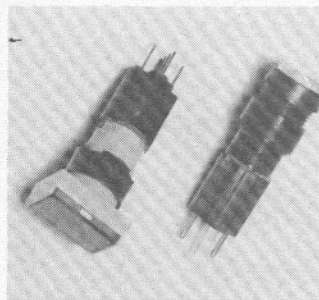

This new Lumotast 75C range which is manufactured by RAFI, is suitable for both IP40 and DIN 40 040 Class applications, has 0.7 mm by 0.5 mm wire wrappable leads and will operate over a temperature range of -25°C to $+70^{\circ}\text{C}$.

The Button tops, which are manufactured in Makralon and available in either neutral, red, yellow, green or blue, can be supplied in either round, square or rectangular design.

EES Ltd.,
98 Croydon Road, Penge,
SE20 7AB, London

(430 M)

New contactless microswitches

Three new ranges of contactless microswitches which utilise Hall Effect IC's, and thereby provide true solid state, bounce free switching, have recently been introduced by EES Ltd.

These long life, high reliability microswitches require a maximum operating force of less than 1.2 N and, under constant environmental conditions have a life in excess of 10^8 operations and a switching point reproducibility of $\pm 3 \mu\text{m}$.

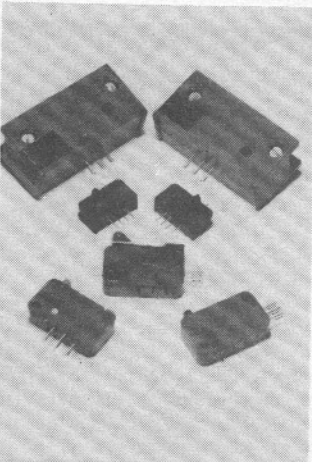

The output is derived from two open collector transistors which generate a static uniphase or

antiphase signal and, with rise and fall times of less than $0.5 \mu\text{sec}$, switching currents up to 500 mA and operating voltages of between 4.5 volts and 27 volts, these contactless microswitches, manufactured by RAFI, will directly interface with all data logic systems.

Designated CM1, 2 and 3, these three sizes of microswitch are mechanically interchangeable with standard mechanical versions, have an operating temperature of -25°C to $+70^{\circ}\text{C}$, are available with either push-on or p.c.b. terminations and comply with the application and environmental requirements of classes HSF (DIN 40 040) and IP40 respectively.

ESS Ltd.,
98 Croydon Road, Penge,
SE20 7AB, London

(425 M)

Prototype Logic Wiring System

The Wire Distribution System from Zartronix is a well-proven point-to-point wiring system. Wiring is carried out using a wiring pencil which carries 36 SWG solderable synthetic enamelled copper wire. The wire is routed and kept in place on the prototype board by special plastic combs.

Connection to IC pins is made

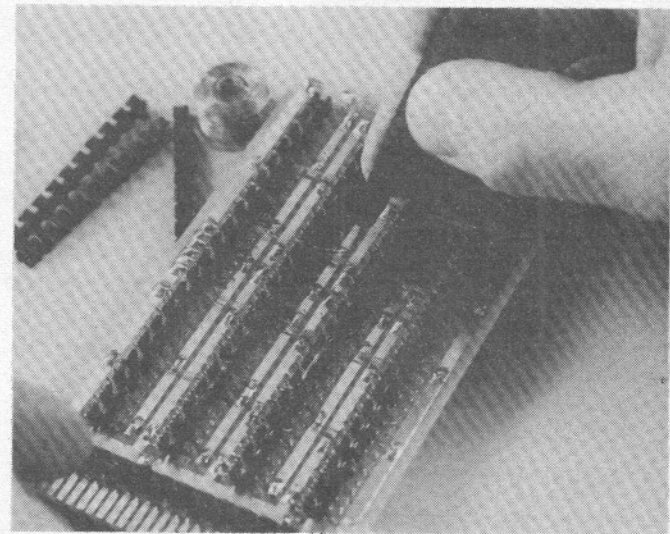

simply by wrapping the wire two or three times around the pin then, when the board is finished, completion of connections is effected using a soldering iron. The application of heat and solder melts the enamel and makes a permanent joint.

Zartronix,
115 Lion Lane, Haslemere,
Surrey

(434 M)

New family of LED indicators

Recently introduced by BOSS Industrial Mouldings Limited is a

new family of low current, low voltage, Gallium Phosphide LED indicators which are fully IC compatible and have fast switching characteristics.

Three types of indicators are available, with the BIM 21 LED being fitted with a choice of two polycarbonate lens styles which are available in red, green, or amber, and give a viewing angle of 55° .

The BIM26 and 56 LED indicators utilise 4 and 5 mm dia. light emitting diodes respectively, which sit forward from the front of the body thus obviating the need for a lens, and giving a viewing angle of 80° .

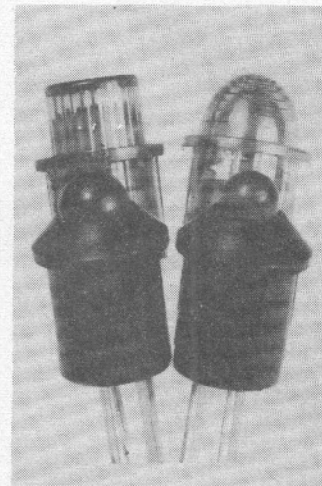

All three types have high luminous intensity figures of between 1.2 and 1.8 mcd at 10 mA, power dissipation of up to 115 mW at 25°C , and will operate over a temperature range of -55 to $+100^{\circ}\text{C}$. Having 23 mm long wire wrappable leads, and being a push-fit into an 8 mm dia. hole, these low cost LED indicators are eminently suitable for both development projects and production equipment.

BOSS Industrial Mouldings Ltd.,
Higgs Industrial Estate,
2 Herne Hill Road,
London, SE24 0AU, England

(427 M)

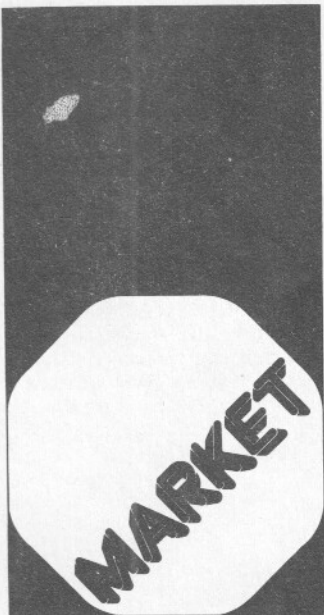

Lloyds approval for Highland switches

The heavy-duty oil-sealed range of switches, (coded series 04), marketed by Highland Electronics Ltd., have received Lloyds Approval under Certificate No. 847 (Rotterdam). This range of switches, introduced in 1975, comprises push buttons, indicator lights, rotary actuators and keylock actuators. Panel mounting is by 22.5 mm diameter circular hole and a modular flexible design is employed so that the actuators, lamp block adaptors and snap-on contact blocks, with toggle or butt action mechanisms, are easily interchangeable.

The contact blocks, up to four on one actuator, are rated at 10 amp 500 volt A.C. max., and are available in normal toggle action or slow make — slow break versions. Two pairs of normally open contacts, two pairs of normally closed contacts or one normally open and one normally closed contacts per block may be specified.

In addition to the recent Lloyds approval, making this range of switches eminently suitable for marine use, the actuators are oilproof and waterproof and conform to IEC 144/IP65 and

DIN 400 50/P54. Swiss SEV 500 V 10 A and Canadian CSA 300 V A.C. approvals also apply.

Highland Electronics,
8, Old Steine,
Brighton BNI IEJ,
East Sussex

(424 M)

New power transistors

Recently introduced by Jermyn Distribution are 3 pairs of NPN silicon power transistors, continuously rated at 5, 8 and 15 amps. Each pair within this series has a sustaining V_{ceo} of either 300 or 400 volts DC at a case temperature of 25°C and power dissipation figures of 100, 125 and 175 watts.

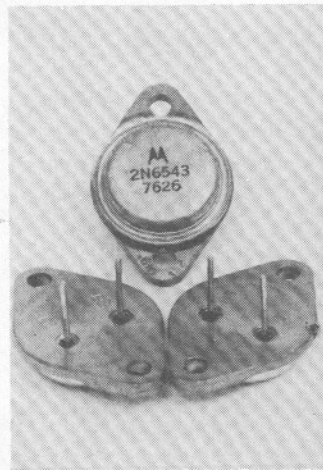

With DC current gains in excess of 60 these 2N6542-7 devices are ideal for high speed power switching in inductive circuits where fall times of less than 800 nsecs are imperative. Capable of operating over a temperature range of -65°C to +200°C, and housed in a rugged hermetically sealed TO3 package which gives low thermal resistance and high reliability, all six devices are particularly suitable for 115 and 200 volts line operated switch mode applications such as switching regulators, PWM invertors, motor controls, as well as solenoid and relay drivers.

Jermyn Distribution,
Sevenoaks, Kent

(426 M)

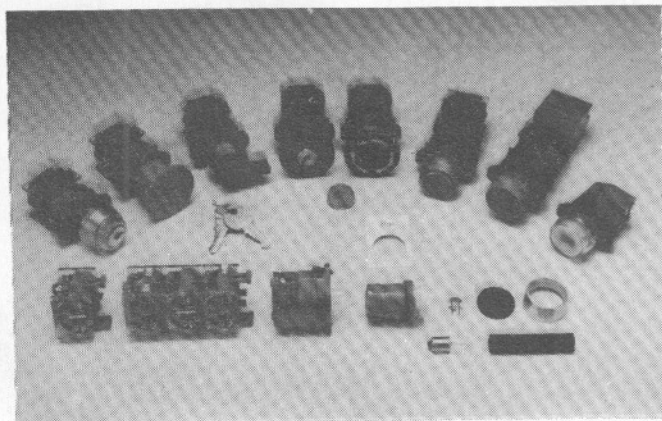

Availability of metal oxide resistors

Compstock is now stocking the full range of Erie MO4 and MO5 miniature metal-oxide resistors. These series, which are available off-the-shelf, have BSI and Post Office Approval and can be released to BS9111-N002 or DQAB 6/49 as appropriate. The resistors are suitable for use in avionic, military and professional industrial applications.

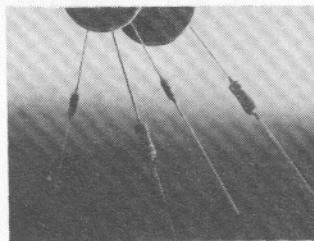

The MO4 is rated at ¼ watt and is available in E12 values from 10 ohms to 270k ohms, the MO5 being ½ watt also available in E12 values from 10 ohms to 330k ohms. Both ranges are stocked in ± 2 percent tolerance. Solderability is to BS2011 and marking to BS2488/BS1852. The MO4 is Post Office style 91F and the MO5 style 91E.

Compstock Electronics Ltd.,
42/44 Bowlers Croft,
Basildon, Essex

(432 M)

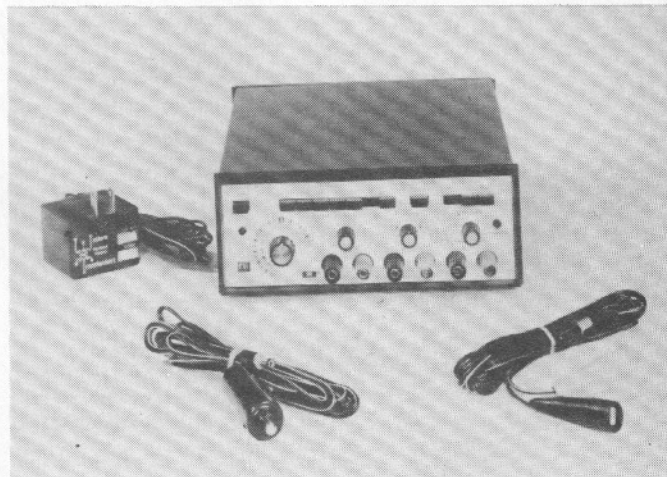

New GaAs FET in low-cost package

The availability of a new gallium arsenide field-effect-transistor (GaAs FET) in a new low cost 70-mil square metal-ceramic package has been announced by California Eastern Laboratories, exclusive U.S. distributor of Nippon Electric Co., Ltd.'s microwave semiconductors. The new device, called the NE 24483 has been widely expected as a broad based replacement for conventional bipolar transistors in 4-8 GHz small signal applications. The device, with a typical 4 GHz noise figure of 1.7 dB and a 13 dB associated gain is better than and competitively priced with the

best commercially available bipolar transistors. The price of the NE 24483 is \$85 (100-999 quantity) and is 'considerably cheaper' for higher quantity orders.

California Eastern Labs,
One Edwards Court,
Burlingame, CA 94010

(428 M)

Portable V.C.F. function generator

Dana Electronics have announced that their associate company, Exact Electronics, have added a new low-cost v.c.f. portable model to their range of function generators. Model 119P is a very compact instrument that can be either mains operated or run from 12 volts D.C., supplied by either its own rechargeable batteries or a car dashboard socket. The in-built batteries will power the 119P for up to 8 hours.

The instrument offers a dynamic frequency range from 0.02 Hz to 2.2 MHz, with sine, square, triangle and variable time symmetry of all waveforms for ramp and pulse operation. A v.c.f. input is provided to allow the generator to be varied either up or down over a range of 1000 : 1. Minus 10 volts D.C. will increase the frequency by three decades from a minimum multiplier setting, and plus 10 volts D.C. will decrease the frequency three

decades from a maximum multiplier setting.

The 600-ohm output of the Model 119P delivers 20 V peak-to-peak open circuit, or 10 V into a 600-ohm load. An amplitude control provides a continuously-variable control of the output voltage, and a D.C. offset control makes available a maximum of ±10 V of output voltage offset. Pulse and ramp waveforms can be reversed in polarity by means of an invert switch. A TTL-compatible pulse output capable of sinking 20 TTL loads is available at the front panel. Price £230.00

Dana Electronics Ltd.,
Collingdon Street, Luton, Beds

(431 M)

