

up-to-date electronics for lab and leisure

ELEKTOR 15/16

July/August 1976
double issue - 80 p



SUMMER CIRCUITS

76



with more
than 100 circuits



contents

About this issue p. 709

Audio	nr	Sundries	nr
class A amplifier re-considered	54	a steady hand	7
Hafner circuit for quasi-quadrophony	86	AMV without R and C	50
hand-effect organ	91	aquastat	10
HI-Z stereo amplifier for headphones	12	battery indicator	22
motorphone	4	bird-bell	87
peak indicator	63	car clock using watch IC	46
piano tuner	61	crystal timebase for synchronous clocks	19
rain synthesizer	6	dark room aid	21
simple headphone amplifier	29	digital speed readout for turntables	71
sound effects generator	81	driving LEDs from TTL	72
speech shifter	60	electronics lap counter	37
stereo indicator	96	electronic voting system	75
super-bootstrap RC oscillator	98	frequency doubler using 4011	17
symmetrical power amp.	89	handy dark room timer	76
three channel mixer	48	ignition key reminder	45
tremolo	65	infra-redphone	94
triangular wave oscillator	36	kettlestat	8
variable slope filter	26	light sensitive astable multivibrator	2
variable stereo width mixing stage	1	liquid level indicator	24
wien bridge oscillator	32	min-max temperature indicator	14
wind machine	34	MMV for ACG	62
7 watt IC audio amplifier	82	moisture indicator	97
		molestation	11
		MOS monostable	43
Power units	nr	on-off-TAP	59
battery charger	84	one-shot	66
cascode current source	67	opto coupler with two LEDs	38
current source	30	perpetual solar clock	42
dissipation dumper	80	poker	57
quad symmetrical supply	99	porch lighter	33
regulated + and -15 V power supply	35	quiz selector	93
symmetrical regulated supply	95	read-out brightness regulator	85
TTL-insurance	28	rev. counter for diesels	20
variable regulated supply	73	Schmitt trigger	58
voltage regulator for motorbikes	92	seat belt reminder	39
0-30 V/1 A, stabilised	55	single transistor sawtooth generator	53
		solarstat	16
		spike monoflop	44
RF	nr	tap doorbell	49
aerial booster	25	tapped code lock	31
aircraft communication receiver	51	touch activated dimmer	77
DSSC generator	83	VCO with 74123	47
preset aerial amplifier	100		
sample/hold synthesiser	69		
simple front-end for VHF FM	68		
single sideband adapter	70		
sqlch	64		
SSB adapter	40		
SSB exciter with HF compressor	101		
trawler band converter	102		
TV modulator	56		
wide band frequency doubler	23		
'wireless' bell extender	52		
200 MHz sample/hold adapter	90		
Test	nr		
audioscope	79		
acoustic logic probe	13		
active oscilloscope probe	27		
linear scale ohmmeter	88		
microammeter	41		
PIP meter	74		
polarity indicator	9		
simple pulse generator	18		
sine-square-triangle generator	5		
test logic	15		
transistor tester	78		
voltage to frequency converter	3		

about this issue

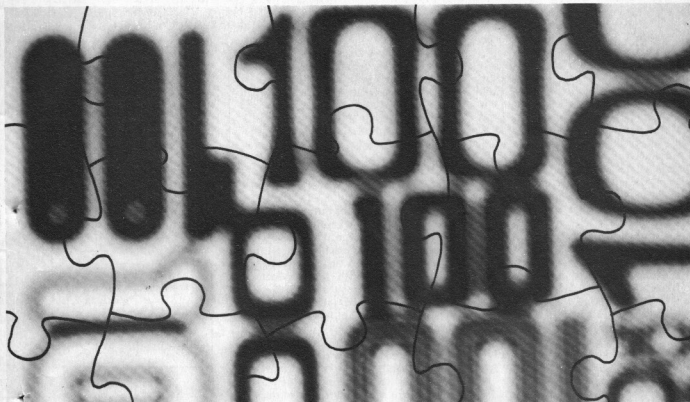

Our often-quoted motto is: 'Elektor is different'.

Well, this issue is even more different. Where a 'normal' issue of Elektor contains about ten or twelve construction articles, the 'summer circuits' issue contains more than 100. This means that our design staff have to dream up nearly as many new circuits for one issue as would otherwise suffice for a whole year.

And the number of circuits needed isn't the only problem. The editor demands that the circuits should be 'new', 'original', 'different'. The chief of design demands that they must work. And the deputy editors for the various editions demand that the components should be available.

We haven't yet reached the stage where every circuit meets all the demands, but nobody can say we didn't try.

Admittedly, some of the designs are based on manufacturer's application notes (for which we thank all concerned), so they are not original - but we have tried to select application notes which are of general interest.

Admittedly, not all circuits have been tested. However, if any member of our technical staff voiced his doubts about a design it was either scrapped or built and tested. The 102 circuits presented here were selected from a total of 231. And that is not counting the hundreds of basic ideas that never got past the first editorial selection. Furthermore, as

a last resort, we have our technical queries service and the 'missing link'. But, if last year's 'summer circuits' issue is anything to go by, the demands on these services should be few and far between.

Admittedly, not all components used will be readily available. This is one of our major headaches. In our first issue we stated: 'The availability of components is always considered, and when new components are needed every effort is made to ensure that they can be obtained through the normal retail outlets.' And we meant it - and we mean it.

Perhaps it should be clearly stated: it is the exception rather than the rule that we specify components that cannot be made available - and this is usually the result of over-optimistic advance information from the manufacturer.

However, the 'normal retail outlets' must buy their components from distributors - and the latter are not always interested. Perhaps they forget that if 10% of our readers want to build a particular project, this means nearly 5,000 potential customers in the U.K. Furthermore, most of the components used in Elektor have been readily available overseas for several years. Even 'on the doorstep', so to speak: in Holland. We would advise our readers not to accept comments like 'The production of the BC547B was stopped several years ago'

without contacting us.

Rest assured, we are still working on this problem. We have now started issuing advance information sheets to the retail trade, listing the components to be used in coming issues of Elektor. Retailers who would like to be put on our mailing list can contact our Canterbury office. We are also contacting major suppliers in the common market, to see whether they will supply the U.K. retail trade - and possibly even the U.K. reader direct. Some readers have asked why Elektor doesn't supply components when these are not readily available. However, our basic policy has been clearly stated from the outset: 'Elektor will not sell components, so that complete editorial independence is assured'.

It is, however, conceivable that if the worst comes to the worst - and in the interest of editorial independence where the choice of components is concerned - we may decide to act as a temporary go-between for the retail trade by offering them the necessary components on a non-profit basis. This would, of course, be stopped as soon as the regular distributors took over. Enough talk about problems. We hope that we have succeeded in finding 'more than 100 circuits' that come sufficiently close to fulfilling all our requirements. We wish you pleasant reading - and soldering!

1 variable stereo width mixing stage

2 light sensitive astable multivibrator

1 This mixing stage is a modular unit of universal design, so that several units can be joined in parallel to form a central control for more complex stereo systems. In this type of system, each stereo source is controlled by its own module; the circuit of one module is indicated inside the dotted line in the diagram. The total (sum) output signal appears across Ra (L) and Ra' (R); the value of these resistances depends on the number of input channels.

Signal sources with output levels of 100 mV or more can be connected straight to the module input terminals; lower level sources and those needing special processing (microphones, dynamic cartridges) will require separate preamplifiers.

Some aspects of stereo width control were already discussed in the 'Preco' articles of earlier Elektor issues (12, p. 416 and 13, p. 516).

Super-stereo is obtained by closing S1; the control range can be increased by reducing R6. P2 is used for continuous width adjustment between mono and super stereo.

The value for the two resistances Ra and Ra' is found by choosing the nearest standard value to 3900 divided by the number of mixing stages. As an example, if five stages are to be used the value should be the nearest standard value to

$$\frac{3900}{5} = 777 \Omega,$$

i.e. 820 Ω . In the majority of cases this common resistance will be sufficiently low to serve as L and R output circuits without further buffering.

The L and R output levels practically equal the sum of the levels at the inputs.

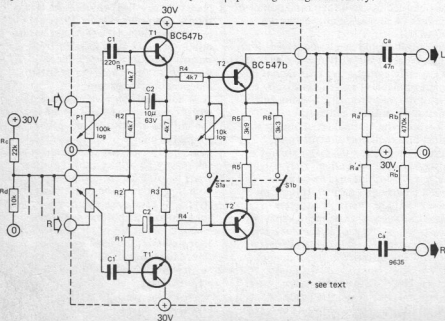

2 The circuit of an astable multivibrator using a Schmitt trigger and a single RC time constant has frequently been used in Elektor. Figure 1 shows how this circuit can be modified so that the frequency of oscillation is dependent upon the intensity of light falling on a phototransistor.

Assuming that C1 is initially uncharged, the output of S1 will be high. C1 will now charge via R1, D2 and T1 at a rate depending on the leakage current of T1, which is in turn dependent on the light level. When the voltage on C1 has reached the upper threshold voltage of the Schmitt trigger the output of S1 will go low and C1 will now discharge through D1 and R1 until the lower threshold voltage is reached, when the output of S1 will go high again and the cycle will repeat. With the component values shown the frequency will vary between about 5 kHz and 10 kHz, depending on the light level incident on the phototransistor.

The disadvantage of this circuit is that the duty-cycle of the waveform varies with the light intensity, since the phototransistor controls only the half-cycle of the waveform when the output of S1 is high. This problem can be overcome by placing the phototransistor at the centre of a diode bridge, and a circuit using two CMOS inverters is shown in figure 2. When the output of N1 is high then current will flow through the phototransistor via D2 and D3. When the output of N1 is low current will flow through the phototransistor via D4 and D1. With the capacitor value shown the frequency of oscillation will vary between about 10 Hz and 1 kHz depending on light intensity.

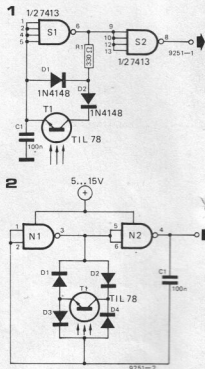

$$N1, N2 = \frac{1}{2} \times 4011$$

$$D1...D4 = 1N4148$$

A circuit using CMOS gates and analogous to figure 1 is shown in figure 3. The phototransistor is connected in a feedback loop around N1 and since the phototransistor will be reverse-biased when the output of N1 is low it controls only the half-cycle of the waveform when the output of N1 is high. The duty-cycle therefore varies with light intensity. This can be cured in this circuit by using an LDR (e.g. ORP12).

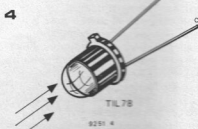
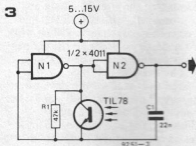

3 voltage-frequency converter

4 motorphone

J. Borgman

instead of the phototransistor. The resistor R1 in parallel with the phototransistor (or LDR) determines the range of variation of frequency and with the component values given this will be between 500 Hz and 1 kHz. The leadout configuration of the TIL78 is given in figure 4.

drops at a constant rate. This continues until T1 is blocked; when this happens, the collector voltage of T1 jumps to the 5 V level, triggering IC2 and producing a positive-going pulse at the Q-output of this IC.

The pulse width is 5 μ s, determined by R11 and C4. During this time T2 is driven into saturation, switching on FET T3 so that C1 is discharged over a constant range. This causes the inte-

4 It is almost always impossible for a motor cyclist and his passenger to maintain aural contact without dangerous acrobatics. The circuit shown in the figure affords effortless voice contact. The microphone amplifier of post 1 is formed by an amplifier stage T1 followed by a super emitter follower. The DC coupling determines the current through R1 and

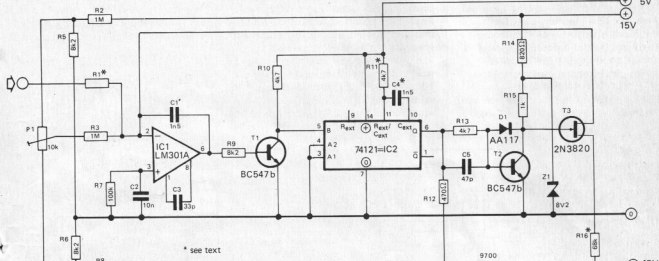

* see text

3 In conjunction with a frequency counter, this unit can be used as a digital voltmeter. The output is a TTL compatible pulse train with a 5 μ s pulse width. The pulse repetition frequency is directly proportional to the input voltage. The conversion factor is 10 kHz per volt. In this circuit, due attention was paid to linearity and zero-point stability. The unit remains linear to about 100 kHz. This means that the upper voltage limit, without external voltage dividers, is about 10 V. The input is connected, via R1, to the opamp (IC1), which functions as an inverting integrator. When a output is applied to the input of IC1, its output

grator output to rise to its original (positive) value. Then the entire process is repeated, again and again. . . The repetition frequency of the resulting pulse train is directly proportional to the input voltage. The value of R1 is about 90 k. It can be composed of a fixed metal film resistor and a stable preset potentiometer, so that the circuit can be calibrated. It is recommended to use metal film resistors for R11 and R16, and polycarbonate capacitors for C1 and C4. With the input short circuited, the frequency should be adjusted somewhere between 0 and 2 Hz by means of potentiometer P1.

the base-emitter voltage of T1. So when one party speaks he hears himself, so that he knows the system is working. Since the two posts are connected in series, the signal generated in post 1 travels through both telephones, so that this 'intercom' needs only one wire between the two posts. The main function of the supply with T7, T8 and T9 is noise suppression, whilst at the same time the system is made short-circuit proof. Via R13 and D2 an audible indication of the trafficators is obtained. The interphone posts can be made so small they can be mounted in the crash helmets. The supply is mounted on the machine. The microphones are crystal types.

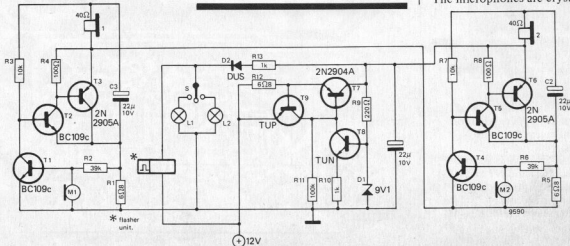

5 sine-square-triangle generator

5 Unlike the more usual type of function generator, in which the sinusoidal output is derived by shaping a triangular waveform, the basis of this circuit is a Wien-bridge oscillator, which provides a sinusoidal output. The square and triangular waveforms are then derived from this.

The Wien-bridge oscillator is built around CMOS NAND-gates N1 to N4, and amplitude stabilization is provided by T1, D1 and D2. These diodes should, if possible, be a matched pair, for minimum distortion. The frequency adjustment potentiometer P1 should also be a good quality stereo potentiometer with the tracks matched to within 5%. The preset R3 provides adjustment for minimum distortion and if matched components are used for D1,

also varies with frequency. In practice the amplitude variation is relatively unimportant, since the generator will usually be used with a millivoltmeter or oscilloscope and the output can be monitored. Adjustment of the triangle amplitude is provided by P3.

As the CMOS gates cannot drive very low load impedances an output buffer amplifier is provided, which greatly increases the usefulness of the generator. The amplifier is capable of driving loads of 4 Ω or greater, which makes it particularly useful for loud-speaker testing. If the generator is likely to be used to generate square-waves at low frequencies (less than 100 Hz) it may be worth increasing the value of C15 to make the top of the square wave flatter. Quiescent current

adjustment is provided by P4 and this should be set to about 50 mA. P5 controls the output amplitude. As the impedances around the CMOS circuits are fairly high the generator should be mounted in a screened metal box to avoid interference pickup. If a mains power supply is used this should be screened from the rest of the circuit to avoid hum pickup. For optimum results at high frequencies C_a (8 pF) and C_b (33 pF) can be added; note that these components are not shown on the layout for the p.c. board.

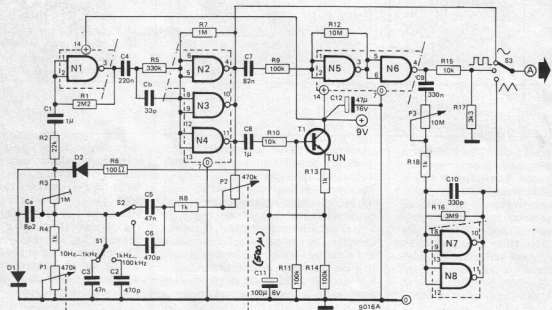

N1 ... N4 = CD4011 = IC1
N5 ... N8 = CD4011 = IC2
D1 ... D2 = 1N4148

D2 and P1 the total harmonic distortion should be less than 0.5%.

The output of the Wien-bridge oscillator is fed into N5, which is biased into its linear region and operates as an amplifier. N5 and N6 together amplify and clip the oscillator output to give a square waveform. The duty-cycle of the waveform is somewhat dependent on the threshold voltages of N5 and N6, but it is close to 50%.

The output of N6 is fed into an integrator constructed around N7 and N8, which integrates the square wave to give a triangular waveform. The amplitude of the triangular waveform is, of course, frequency dependent, and since the integrator is not perfect the linearity

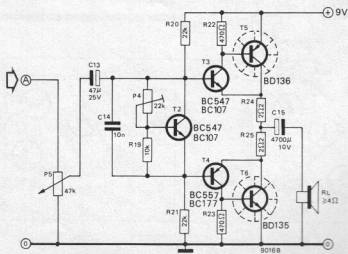

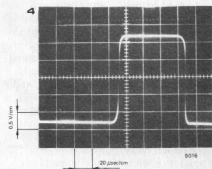
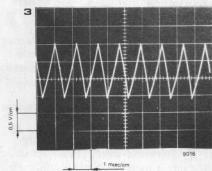
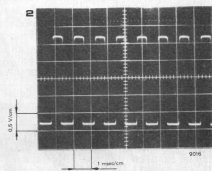
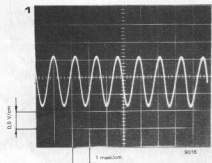
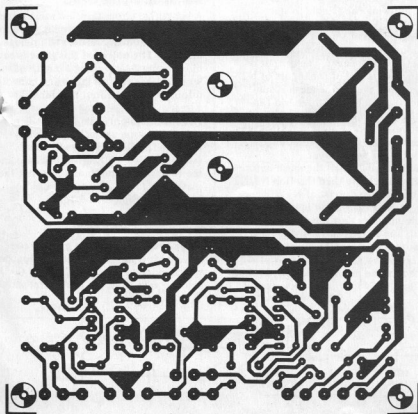
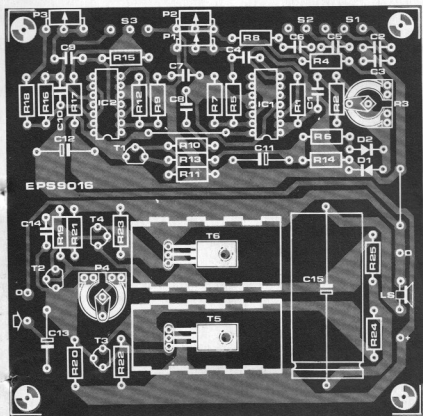

6 rain synthesiser

R. Otterwell

7 a steady hand

6 This simple circuit has proved very reliable and effective as a background sound effect generator for use by organists etc. Other simple devices of this type often use several stages of amplification or make use of special noise diodes which are comparatively expensive. The advantage of this design is that it employs an ordinary OA 91 or similar diode. The

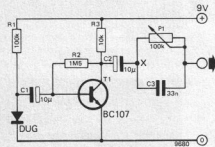

internal noise produced by the diode is amplified by the single stage pre-amplifier, consisting of T1 and its associated components, which is designed for high gain and low cost. T1 can be almost any silicon NPN transistor, a BC107 being used in the prototype.

The output at X may be taken straight to an amplifier if only a white noise output is required. However, the addition of the passive filter, comprising C3 and P1 enables a variety of effects ranging from light rain to a heavy storm to be obtained.

7 This is a game of skill requiring 'nerves of steel'. The object of the game is to pass a metal rod through one of the holes in a sheet of chicken wire and to touch a metal plate located some 6-12 inches behind the wire — without touching the wire. When the plate is touched a buzzer will sound and a LED will light, but if the rod inadvertently touches the wire before reaching the plate the buzzer will sound and a different LED will light. The plate and the chicken wire form the contact plates of touch controls, so no circuit connection is required to the rod, the circuit operates simply on hum picked up from the player's body.

The heart of the circuit (figure 1) consists of two set-reset flip-flops constructed around CMOS NAND gates N1/N2 and N3/N4. Initially the circuit is reset by pressing the reset button. This takes one input of N2 and N3 to '0' via diodes D1 and D2, so the outputs of these two gates are high. The output of N5 is thus low and the astable multivibrator N6/N7 is disabled. The

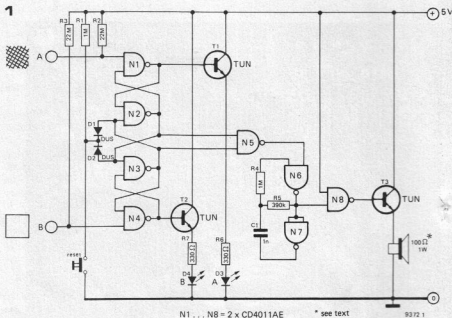

outputs of N1 and N4 are low, T1 and T2 are turned off and both LED's are extinguished.

If the player succeeds in touching the plate (B) without touching the mesh (A) the hum picked up from his body will set flip-flop N3/N4. The output of N4 will go high, turning on T2 and lighting LED B. The output of N3 will go low, so the output of N5 will go high, allowing the astable to start oscillating. Via N8 this switches the Darlington pair T3 and T4 on and off at about 1 kHz, and produces a tone from the loudspeaker. The output of N3 also holds one of the inputs of N2 low, so that even if the mesh is subsequently touched with the rod flip-flop N1/N2 cannot be set, but remains in the reset state. Flip-flop N3/N4 must be reset by pressing the reset button, ready for the next player.

Should the rod touch the mesh before reaching the plate then flip-flop N1/N2 will be set. The output of N1 will go high, turning on T1 and lighting LED A, which indicates that the player has failed. The output of N1 will be low, the output of N5 will be high and the 'buzzer' will sound. The output of N2 also holds one input of N3 low, so that flip-flop N3/N4 cannot be set, even if

the plate is subsequently touched.

A typical method of construction for the game is shown in the photograph. The circuit can be mounted in a small box behind the metal backplate. This does not need to be solid metal of course, but can be a sheet of plywood covered with aluminium foil.

Variation on the Game

A simplified (from the electronic point of view) version of the game is given in figure 2, and many readers will recognise this. The object of this game is to move a metal loop along a length of wire that has various kinks and convolutions — again without touching the wire.

For this game only one flip-flop is required. As soon as the loop touches the wire flip-flop N1/N2 will be set, astable N3/N4 will start to oscillate and the tone will sound, indicating that the player has failed. The circuit can be reset by pressing the button.

Constructional points

If the first version of the game is constructed it is important that the spacers, which separate the frame holding the chicken wire from the backplate, should

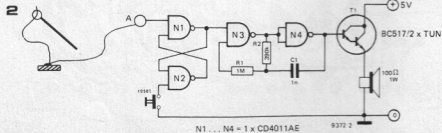

8 kettlestat 9 polarity indicator

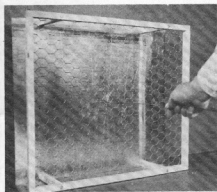

made of insulating material. The whole frame should also have an insulated base, so that it will not be grounded if placed on a conducting surface such as the earth.

The same considerations also apply to the second version of the game. The length of bent wire must be mounted on an insulating base or in an insulated frame of some kind. The wire should also obviously be fairly stiff, and 2 mm piano wire is a suitable material. The loop can also be made from a piece of the same wire.

8 Automatic kettles which will switch themselves off after they boil are very convenient, but also expensive. For a component cost of about £ 4,— a normal electric kettle can be converted for automatic operation. A circuit using an NTC for the temperature sensing element, will work well.

Operation

Normally the NTC's resistance is high, which means that the input voltage to

the Schmitt trigger is low. Therefore, T1 is off and T2 is on, so T3 is conducting and the relay is closed. As long as the relay remains closed, the triac will be continuously triggered, allowing current to flow to the kettle's heating element. When the water boils the steam heats the NTC, causing its resistance to go down, in turn the voltage to the Schmitt trigger goes up. When the voltage reaches the threshold voltage, T1 turns on and T2 and T3 turn off, the relay opens and the triac stops conducting — switching off the current to the kettle. A LED indicates the water has boiled. A large degree of hysteresis is built into the Schmitt trigger which ensures that the kettle will not switch on again until the NTC has cooled almost to room temperature. There is little chance of the kettle boiling dry unless it is left unattended for several hours. On the other hand the water will be heated up to the boil every few minutes and will thus be kept hot. To bring the water back to the boil manually a push button switch (S) is provided. Pressing it resets the Schmitt trigger even if the NTC has cooled sufficiently for the input voltage to fall below the turn-off threshold.

Construction

There are two possible methods of construction. The circuit can be mounted in a small plastic box attached to the kettle plug with the NTC mounted on a small arm. A hole about 4 mm diameter is drilled in the back of the kettle (above the wareline) to allow steam to pass over the thermistor. The second method is to mount the components in a box with a 13 amp socket into which the kettle is plugged. The thermistor may then be mounted in a probe made

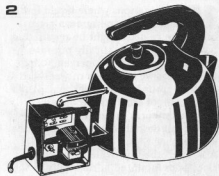
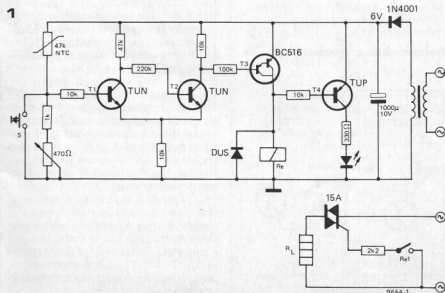

from an old ball point pen which is inserted in the kettle spout. In either case great care must be taken with the insulation. All the mains connections should be well insulated from the low-voltage circuits and the components should be fixed in the case with nylon screws.

9 With this device it is possible to determine the polarity of test points with respect to the circuit common.

The indicator is built around the 741 opamp. It has an input impedance of about 1 MΩ, so that there is little

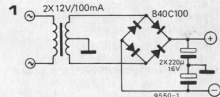

circuit loading by this device.

However, when checking circuits with high impedances, the loading effects must be taken into account.

The opamp compares the voltage of

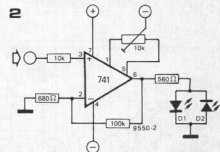

the test point relative to common. If the voltage is positive so is the output of the opamp. As a result LED D1 will light. If the voltage is negative, LED D2 lights up. The pin numbers given on the drawing are related to a TO-5 case.

10 aquastat

H. Frakstein

11 molestation alarm

12 Hi-Z stereo amplifier for headphones

10 In situations where liquid levels should not transgress a given maximum value it might be required to have a pump automatically put into operation in a case of emergency. In this respect we can think of well-head control, ground water level control and other cases of emergency concerned with waterworks in general. Perhaps the circuit described here can mean the solution.

A P.V.C. tube is provided with three electrodes mounted horizontally in the space c.q. place to be controlled (figure 2). Via a sturdy (weather-resistant) three-core cable these electrodes are connected to the control circuit. The bottom electrode is connected to plus, electrode 'N1' to the base of T1 via a series resistor Rx, and 'N2' to the base of T4 via a resistor Rx. The positions of 'N1' and 'N2' on the P.V.C. tube correspond to the critical liquid levels.

The circuit functions as follows:

— Suppose that for some reason the water rises from an initial level situated between electrode '+' and electrode 'N1'. As soon as the water reaches level 'N1', there will be an electric contact between '+' and 'N1'; T1 is driven open via Rx, the collector of T2 is 'high', and T5 could become conductive were it not that T6 is not (yet) conducting. The transistor can begin to conduct only when level 'N2' is reached; for then T4 becomes conductive and T3 is blocked. When both T5 and T6 are conducting, the relay is energized and the pump is switched on. The base and collector of T6 are short circuited via a second make contact on the relay; which means that the relay remains energized even when the level is pumped down again to below 'N2'. The latch is removed from the relay only after the level has dropped below 'N1'; then T5 is not driven, T5 and T6



block, the relay cuts out, and the pump stops.

The values of the resistors Rx must be found by experiment. Generally, these values will lie around 150 kΩ. The current through the electrodes should be kept at a minimum in view of electrolysis phenomena. Owing to the low current consumption the power supply can be quite simple. Depending on the application, an aquarium or fountain pump can be used; if necessary, with the inclusion of an additional transformer.

Warning — To ensure safe operation, the primary and secondary of the mains transformer (if used) should be well insulated! Furthermore, a series resistor (of, say 47 k) can be included in the lead to the '+' electrode, provided the values of Rx are reduced to approximately 47 k.

11 Take a 555 timer IC, connect it as an astable multivibrator with a duty cycle of about 5%, use this signal to drive a miniature loudspeaker via a BD 136, and the result is such a sound that any hostile intentions of a would-be attacker are converted (hopefully) into the well known urge to get away. At the same time, people in the area should become curious and inclined to track down the source of the noise. The circuit can be made very compact and consumes about 50 mA when the power supply voltage is 9 volts.

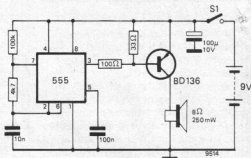

12 This amplifier is intended to be used in conjunction with the popular Sennheiser stereo headphones (HD 414, HD 424). These headphones have a 2 k impedance. According to the factory specifications, a voltage of 1.41 V_{rms} is needed for a sound pressure of 102 dB. (That is 4 V_p - p, or 1 mW into 2 k).

To meet the needs of the hard of hearing, an output of at least 40 V_p - p can be reached with this design, so that a maximum sound pressure of about 122 dB is obtainable. This is not recommended, however . . .

Each channel uses 2 of the 4 opamps in an LM324. The headphones (the load) is driven by two emitter followers T1 and T2 connected in a bridge circuit. IC 1a and T1 provide the necessary amplification, set by R3 and R4 at x 30. At the same time T1 drives the other amplifier in anti-phase via R6 and R7. The input impedance is quite high as a result of bootstrapping via R1 and C2, so that it is possible to obtain the audio signal from a high-impedance point in the pre-amp. Other sources are also possible, like the 'monitor' output of a tape recorder.

Except for R10, R11 and C4, each part occurs twice on the p.c. board; components with an apostrophe belong to the right channel. The space on the p.c.b. which is reserved for the heatsinks for T1, T2 and T1', T2' is somewhat limited, but these heatsinks may touch each other.

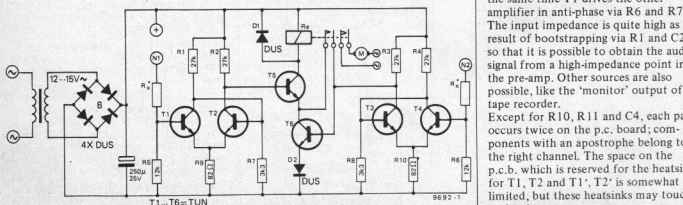

13 acoustic logic probe

The gain of the total amplifier is $2 \times (R3 + R4)/R4$. Using the indicated values for R3 and R4 the gain is approximately 60. If the available input voltage is higher than necessary, it is recommended to reduce the gain by selecting a higher value for R4.

It should be noted that the amplifier outputs are floating! This amplifier can not be used with headphones which use a common return lead. In other words, the two earphones must be completely isolated from each other.

The frequency response is within 3 dB between 20 Hz and 25 kHz. The supply voltage should be between 25 and 30 volts. Current consumption will be less than 125 mA.

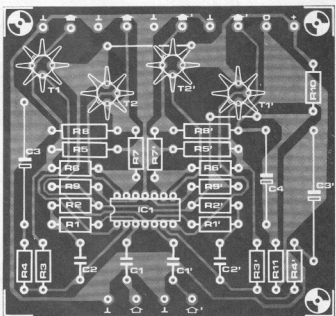
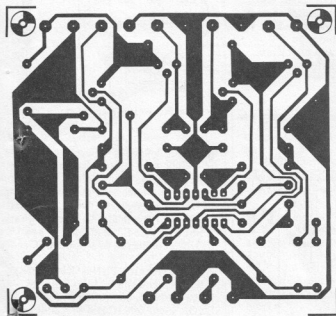
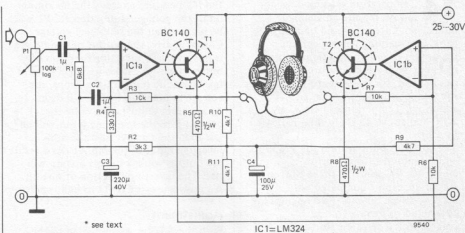

13 This logic probe is a little unusual, as it indicates the logic states by audio tones rather than the normal light display (LEDs, etc.). The audio tone generator used to make the high and low notes, which correspond to the high and low logic levels, is formed by S1 and R4. These two parts form an astable which is tuned by C1 or C2. The signal is buffered and amplified by S2 to drive the loud-speaker.

The way the probe detects different logic levels is very simple. If the input signal voltage exceeds 2.4 V (this level is set by P2) transistor T3 will be driven into saturation. This in turn causes one side of C2 to be connected to (probe) common, so that the oscillator produces a high frequency tone.

When the probe is on a 0.8 volt level or less T1 will cause T2 to saturate, so that

the left side of C1 is connected to common through the low resistance of T2. This produces the low note. The 0.8 V level is set by P1.

The capacitance of C1 should be about twice that of C2, this makes the tone for the low logic level about one octave

below the high tone. The device is inoperative at test levels between approximately 0.8 and 2.4 V, or if the probe is not connected to the circuit. The acoustic probe can be powered by the supply in the circuit that is being tested.

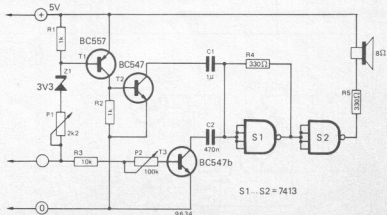

14 min-max temperature indicator

15 test logic

J. Kefer

16 solarstat

14 Temperature reading does not always require an analogue indication. Often it would be nice only to receive warning when a certain maximum or minimum temperature is reached. Such a temperature indicator can be used, for instance, to monitor the temperature of water in an aquarium. Temperatures below, say, 20°C and above 25°C are then indicated by LEDs.

The circuit is built around the LM3900, an IC containing four Norton amplifiers. In principle these Norton amplifiers can be compared with a current-driven opamp. Two opamps are connected to form a voltage comparator. The other Norton amplifiers serve as buffer stages. The entire circuit is fed from a stabilised supply. A reference voltage is obtained by means of voltage divider (R3-R4). The temperature sensor is an NTC-resistor. This NTC resistor (R2), together with P1, forms another voltage divider. The voltage at junction R2-P1 is thus temperature-dependent. The opamps A1 and A3 compare this voltage with the reference voltage. When

the temperature exceeds the maximum limit, the voltage at junction R2-P1 will be higher than the reference voltage.

Consequently, the output of opamp A3 is positive. The inverting function of buffer stage A4 causes LED D3 to light up. When the temperature drops, the voltage at junction R2-P1 will drop. At a certain (adjustable) value the current into the inverting input will be less than the current into the non-inverting input of opamp A1. As a result the output voltage of this opamp will rise. The inverting function of opamp A2 now causes LED D2 to light up.

Adjustment

With the NTC in water heated to the maximum permissible temperature, P1 is adjusted so that LED D3 is just lighting up. Allowing the water to cool to the minimum temperature, adjust P2 so that LED D3 just comes on.

Note that the connections which are immersed in water must be well insulated, of course.

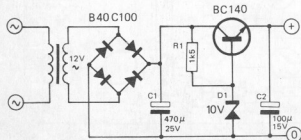
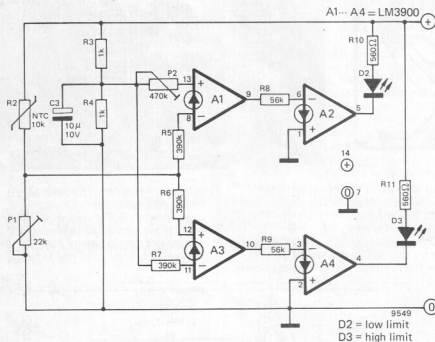

15 This test probe is suitable for measuring three TTL-logic levels: the usual levels '0' and '1' and the non-defined region between the two. When the circuit sees a '0' the TUP is saturated, turning on the '0' LED. If

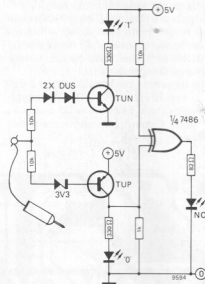

the input voltage is between one and two volts, both transistors are blocked. This means the exclusive OR (EXOR) receives two unequal logic levels making its output go high; the 'NC' LED lights up. This LED will also be lit if the probe is not connected to a measuring point or when connected to a floating IC input pin.

Above 2 volts the TUN is driven into saturation and the '1' LED lights up. Since a 7486 is comprised of four EXOR gates, one IC and a small handful of parts could be turned into a 4 channel logic analyser.

16 Solar water heaters are becoming popular due to the current interest in energy conservation. Water is pumped through solar collectors mounted on the roof and, when hot, is used to heat up the domestic hot water supply in a normal two circuit hot-water tank.

However, it is pointless pumping water through the solar collectors on a cold day when the temperature of the collectors is less than the domestic hot water temperature (which will then be heated by other means) as the solar collectors then become very effective radiators. What is required is a differential thermostat that will start the pump only when the temperature of the solar

17 frequency doubler using 4011

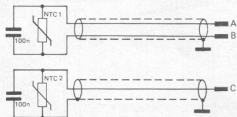
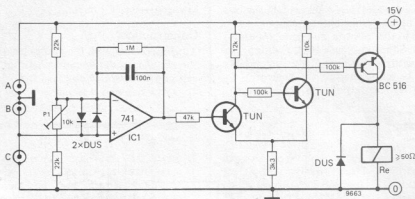

panels is higher than that of the water in the tank.

The circuit operates as follows: Temperature sensing is carried out by two negative temperature coefficient thermistors, one on the solar roof and one on the tank. These form two arms of a bridge, the other two arms being formed by two fixed resistors and a preset pot. When at the same temperature the two NTC's have nominally equal resistance and the bridge is balanced (P1 allows adjustment to compensate for differences in the NTC's). If the thermistor on the roof becomes hotter than that in the tank its resistance becomes lower, the voltage on the non-inverting input of IC1 exceeds the voltage on the inverting input, and the output goes high. The Schmitt trigger switches and the relay closes, turning on the pump. If the temperature of the solar roof falls below the temperature of the tank the voltage on the + input of IC1 falls below the voltage on the - input, the output goes low and the relay drops out. The Schmitt trigger ensures clean switching of the relay, which eliminates relay chatter at the switch over point. The unit is calibrated in the following manner. Firstly, both thermistors should be clamped to an aluminium plate so they will remain at the same temperature during calibration. Place the thermistors in near boiling water, allow them to stabilize, then adjust P1 so the output of the IC is low. After this, remove the thermistors from the water; monitor the IC output, making sure the output stays low as the thermistors cool. This ensures that the

temperature of the roof thermistor must always be higher than that of the thermistor before the relay will switch on.

17 This frequency doubler uses one CMOS quad, two-input NAND gate package type 4011. The frequency doubler proper consists of an inverter N2, two differentiating networks R1/C1, R2/C2 and NAND gate N3. N1 and N4 function as input and output buffers.

The incoming signal is buffered and inverted by N1, giving waveform (A) (it is assumed the waveform has 1:1 mark-space ratio). (A) is inverted by N2, giving waveform B, which is the complement of (A) (i.e. it is antiphase). The negative-going edges of waveform (B) are differentiated by R2 and C2, giving waveform (C), while (A) is differentiated by R1 and C1, giving waveform (D). Waveforms (C) and (D) are fed into N3, and every time one of these waveforms is negative-going a

positive-going pulse appears on the output of N3, (waveform E). The output of N4 is an inverted version of (E). The switching threshold of CMOS logic is about 45% of supply voltage, so the switching point of N3 on the rising exponential portions of waveforms (C) and (D) will occur at this point. The time taken for the waveform to rise to this voltage is just less than the time constant RC, so the pulse duration of waveform (E) is approximately equal to the time constants R1C1 and R2C2. For reliable operation these time constants should be chosen to be much less than the shortest possible period of the input waveform. The reason for this is that the width of the positive-going pulses (E) is constant, but the length of the spaces between them diminishes as the input frequency increases. If the pulses are not of short enough duration they may overlap at high input frequencies.

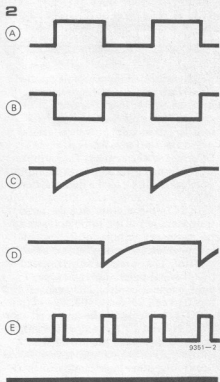

1

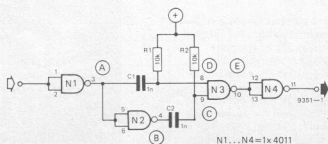

N1...N4=1x 4011

18 simple pulse generator

J. Bonthond

18 A pulse generator is an extremely useful tool for investigating the dynamic behaviour of logic circuits. The circuit described here is based on the versatile 555 timer, and provides variable pulse length and repetition frequency.

zener diodes D1 and D2 protect the input of N4 against excessive input voltages to the 'ext trig' and 'gate' inputs. With S4 in the 'single-shot' position the set-reset flip-flop comprising N1/N2 can be set by pressing the single-shot button. The output of N3 will thus go

low, triggering IC2 once.

Construction

All components with the exception of the switches, potentiometers and timing capacitors C1 to C11 and C14 to C24

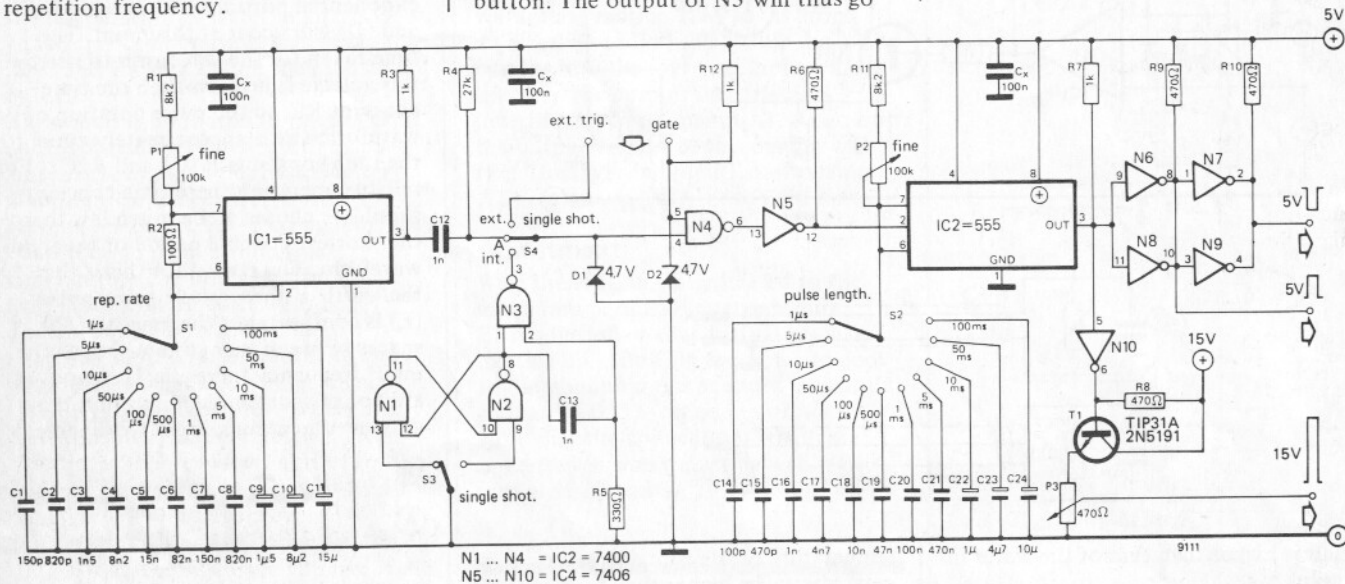

IC1 is connected as an astable multivibrator, whose repetition frequency depends on R1, R2, P1 and the switched capacitors C1 to C11. The switched capacitors provide coarse control of the pulse interval, while P1 provides fine control. The output of IC1 is taken via a differentiating network R4/C12 to the mid-position of S4.

With S4 in the mid-position the pulse train from IC1 is fed through N4 and N5 to the trigger input of IC2, which is connected as a monostable multivibrator. This is repetitively triggered by the input pulses and the output pulse length is controlled by capacitors C14 to C24 and by P2. The output of IC2 is buffered by the inverters N6 to N9 and a TTL compatible output and its complement are provided at the outputs of N7/N9 respectively. For testing other logic families such as HLL or CMOS a variable amplitude output is provided by the emitter follower T1. The amplitude may be adjusted by P3. If this option is adopted a 15 V collector supply to T1 is required.

In addition to a continuous pulse train the circuit also has facilities for external trigger, external gating of the pulse train and single-shot operation. With S4 in the mid-position the pulse train from IC1 may be interrupted by applying a logic '0' to pin 5 of N4. With S4 in the 'ext' position the output of IC1 is disconnected and IC2 may be triggered from an external source. The

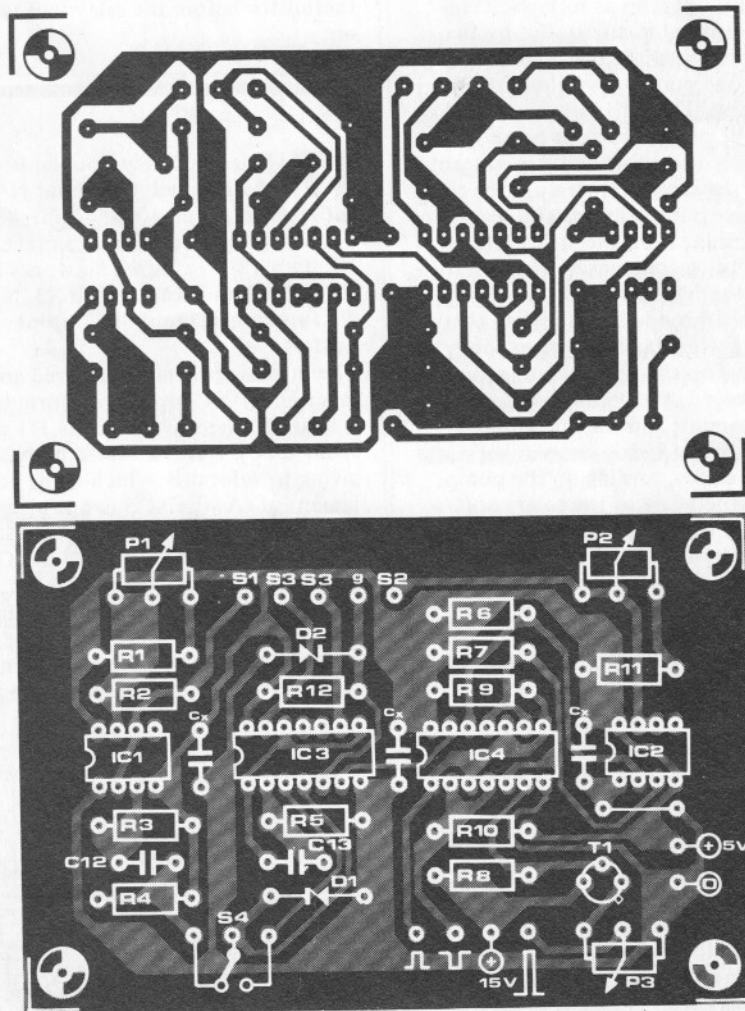

19 crystal timebase for synchronous clocks

20 rev. counter for diesels

F.A. Heinrich

are mounted on the p.c. board. Switches S1 and S2 can be made up from the 'maka-switch' type of assembly, using an 11- or 12-way wafer and a dummy wafer for each switch. The timing capacitors can then be mounted between the tags of the switch wafer and the dummy wafer.

19 Many people prefer a conventional clock face to a digital readout and under normal circumstances the conventional mains driven synchronous clock provides good accuracy at low cost (typically £ 5 -

NiCad battery would keep the clock running for 8 hours in the event of mains failure.

The circuit operates as follows: The reference frequency is provided by a 1 MHz crystal. Other frequencies may, of course, be used, but 1 MHz xtals are readily obtainable. The output of the xtal oscillator is divided down to 50 Hz by CMOS dividers and a complementary darlington output stage provides the drive to the primary of the step-up transformer (which is simply a normal mains transformer reversed). The output capacitor and choke form a filter so that the waveform reaching the transformer is reasonably sinusoidal.

must be provided with a vane which periodically intercepts the light incident on the light sensor. Little can be said about the choice of light sensitive element, because they come in numerous types. Instead of a photo diode, photo transistors or photo darlington can be used. In practically all cases it will be necessary to experiment with the value of R1. A first setting can be obtained by applying half the supply voltage to point A by means of R1.

For slow-running machines, D1 can sometimes be replaced by an LDR. As soon as more light is incident on D1, the current through D1 will increase so that the voltage on point A drops. Via C1 and C2 this voltage drop is fed to the monostable multivibrator N2/N3.

In the quiescent state both inputs of N3 are earthed via R5, so the output of N3 is 'high'. Consequently, the two inputs of N2 are 'high' so that its output is 'low'.

As soon as a negative pulse arrives at one of the inputs of N2, the output of N2 changes to 'high' and causes gate N3 to change state, so that the second input of N2 goes 'low'. Even when the trigger pulse on the input of N2 cuts out, the circuit remains in this condition. Only after C3 (+C4) is (are) charged to such an extent that the voltage on the inputs of N3 are 'low' again will the circuit return to the initial state. Thus the monostable multivibrator changes any input pulse on D1 into a pulse of constant width. These pulses are fed to the meter via buffer stage N4.

The lamp in the supply line provides a better stabilization than a resistor, at the same time giving an on/off indication for the meter.

The measuring range can be doubled with S1. When S1 is closed, the range is from 0 to 33 Hz (0 - 2000 r.p.m.); when S1 is open the range is from 0 to 66 Hz (0 - 4000 r.p.m.).

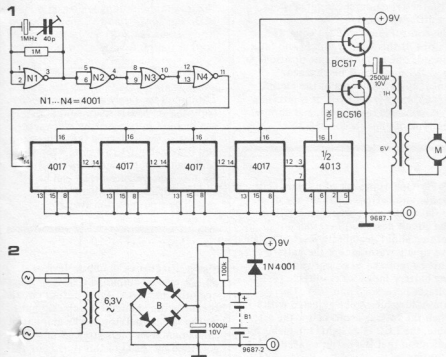

£ 10) Unfortunately, in countries where the mains supply frequency is subject to fluctuation, or in rural areas in this country where power failures are frequent, the mains driven clock is not such a good idea. The alternatives are battery clocks that offer inferior accuracy at about twice the price or, for the very rich, crystal controlled battery clocks starting at about £ 35.

A third alternative is to provide a synchronous clock with a crystal timebase, which divides down a frequency of say 1 MHz to give a 50 Hz signal which is then used to drive the clock through a step-up transformer. The power consumption of a synchronous clock is about 1 - 2 W, so if a 9 V battery supply is used the current drain will be of the order of 250 mA, allowing for transformer inefficiency and power consumption of the dividers, so a 2 Ah

20 The peculiarity of this rev. counter is that it responds to differences in luminous intensity. Consequently, if this circuit is to be used as a rev. counter, the motor shaft

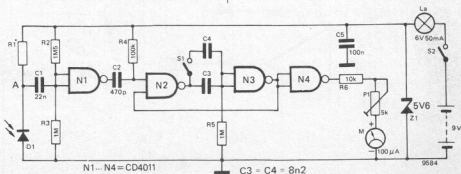

* see text

21 dark room aid H.F. Blom

22 battery indicator

23 wide band frequency doubler

21 This circuit is intended as an aid in the dark room to ensure correct exposure time without effort. Before the paper is placed under the enlarger, the amount of light is measured by means of an LDR. This is the light-sensitive element. The LDR makes up one branch of a bridge circuit, which is formed by the LDR, R1, R2 and part of P2. The other branch consists of P1, R3, R4 and a part of P2. With P2 in centre position, and P1 adjusted to a resistance value lower than that of the LDR, the voltage at the + input of the op-amp is lower than the voltage at the - input. With this condition, the output voltage of the op-amp is negative, and D1 lights up. On the other hand, when the resistance of P1 is higher than that of the LDR, the output is positive, and D2 lights. If the voltages on both inputs are equal, both LEDs light at half brilliance. This is due to the fact that hum is picked-up by the high sensitivity op-amp. Thus the circuit indicates when the resistance values of the LDR and P1 are equal. When the LDR is placed under the enlarger, its resistance value will correspond to the light intensity.

P1 is now adjusted until the bridge is balanced, after which the exposure time can be read from a calibrated scale attached to P1. By adjusting P2 slight changes to the bridge balance are possible. In this way it is possible to introduce corrections for different sensitivities of the photographic paper. This dark room aid has only one drawback: the scale calibration of P1 can only be obtained by spending some evenings in the dark room. But, of course, for the real enthusiast, this is no problem at all! The LDR must be mounted in a flat holder and be partly covered by a mask. This method allows spot measurement

and also helps adapt the LDR to the circuit. To calibrate the unit, first of all ensure that the bridge can be balanced with P1 over the entire range, from extreme light to extreme dark. If not larger or smaller apertures in the LDR mask can be tried. After this, by using an ohm-meter, P1 can be provided with a scale.

For example: P1 = 500 Ω gives one second, 1 kΩ gives 2 seconds, and so on until P1 = 32 kΩ which corresponds to 64 seconds. By means of test strips and an 'average grey' negative, the exposure time can now be brought into accordance with the sensitivity of the photographic paper by means of P2. To this end, P2 is also provided with a scale with the type numbers or gradations for different papers.

The control range of P2 is equal to 4 stops. If this scale is shifted too far towards one of the extreme positions, the LDR mask must be changed. Since only a small area of the picture is measured by the LDR, it is possible to determine the contrast, and choose the type of paper accordingly.

22 One drawback of primary cells and batteries is that they often go flat at the most inconvenient times. The circuit described here can do nothing about dead batteries, but it can give timely warning that the batteries must be replaced or charged soon. The battery indicator is suitable for voltages between 3 and 15 V; the threshold value can be adjusted with P1. When the voltage drops below the set value, the LED (D1) lights up, giving an indication that the batteries need attention.

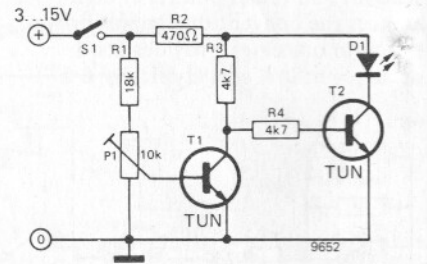
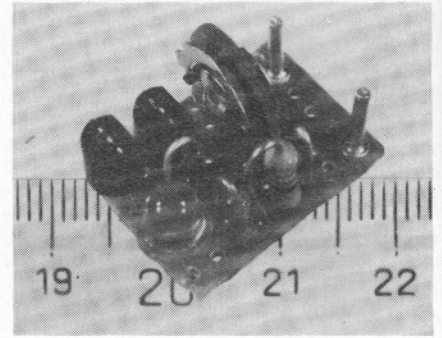

The circuit uses only a few components, requiring very little space so that it can be built into miniature radio sets. As long as the battery is O.K., the circuit draws about 1 to 3 mA; when the LED lights up, this increases to 5 to 15 mA. To save current, S1 can be added which can be either a toggle switch or a push-button switch.

23 Frequency doubling devices usually employ a transistor stage operating in class C. In its output circuit there is a tuned circuit which resonates on the second harmonic. The amount of fundamental frequency rejection is governed by the Q of this tuned circuit. However, when a frequency doubler based on the SO 42-P is used, a 100 ohm pot is used to reject the fundamental. At 10 MHz, and as long as the input signal does not exceed 30 mV rms level, 40 dB fundamental suppression can be obtained. The output capacitance of the circuit is 6 p.

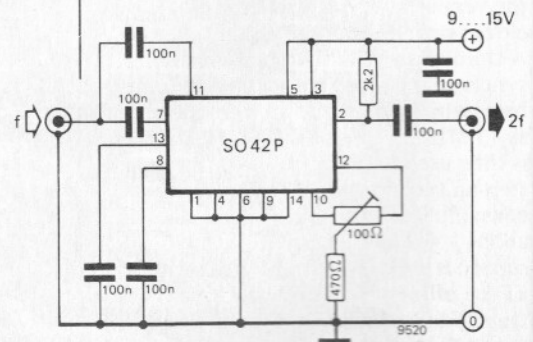
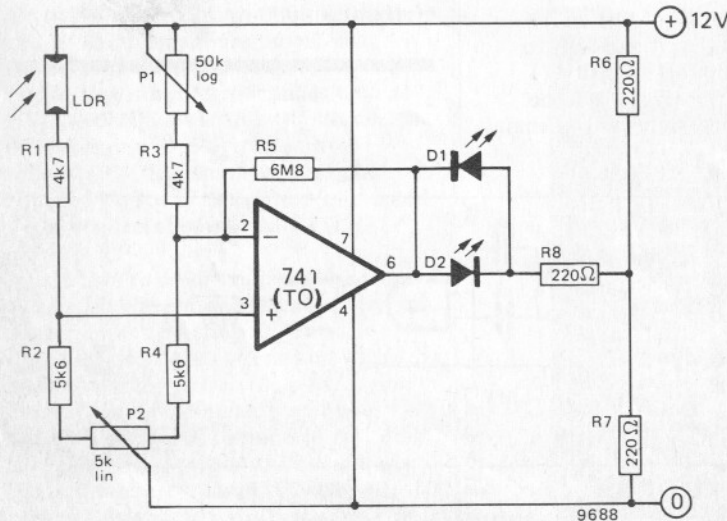

24 liquid level indicator

25 aerial booster

26 variable slope filter

24 This circuit was originally intended as a water level indicator for use by blind persons, to give an audible indication when a cup, bowl or other container was full. It will function with any liquid that will conduct electricity, such as beer, tap water, tea, milk. It will, of course not function with distilled or de-ionised water. The circuit has other applications such as a rain sensor (when used with a suitable probe).

The circuit is extremely simple. The input of N1 is normally held low by a 1M resistor. When the probes are immersed in a conducting liquid the input of N1 goes high, so the output goes low and the output of N2 goes high, enabling the astable multivibrator N3/N4, which switches T1 and T2 on and off to produce a tone from the speaker. An open collector transistor output is also provided to drive a relay or other circuit. Probe construction for level sensing and for rain sensing are shown in figure 2. The level sensor probes should preferably be made of stainless steel wire for ease of cleaning, and the circuit housing should be watertight in case of accidents.

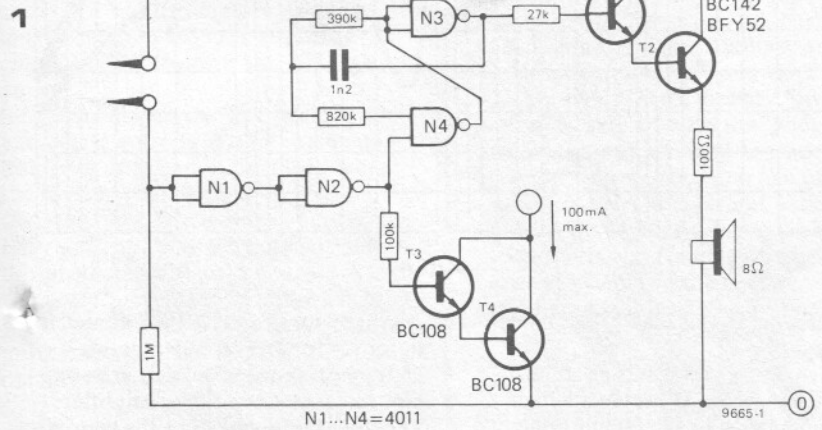
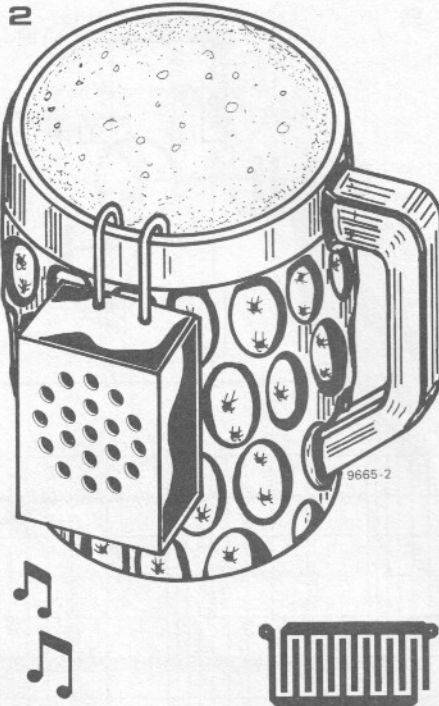

This booster design was tried in front of a variety of receivers with good results. The average voltage gain figure proved to be about 12 dB.

The preamplifier design is quite straightforward, using a common base configuration conditioned for minimum noise. 75 ohm antenna systems can be coupled straight to C1. For 300 ohm systems a matching transformer L1 can be made, by winding a 2 turn primary and a 1 turn secondary on a ferrite bead. Use 0.3 mm enamelled wire (SWG33). The output matching transformer is wound on a 6 mm (1/4") diameter coil form. It should have a ferrite slug with a permeability $\mu r = 12$. Using 0.9 mm enamelled wire (SWG21) the primary (L2A) has 4 turns while the secondary (L2B) has 2 turns.

The circuit is not particularly critical to operate, provided that due care is taken in the construction of the amplifier and long connections are avoided. The transistor screening pin can be connected to the base, as shown in the drawing, or straight to the p.c. board common.

The only circuit requiring adjustment is the primary of the output transformer, L2/C4. This adjustment is carried out by tuning the FM set to a station at approximately 95 MHz. C4 is then set to minimum capacitance, after which L2 is set for maximum signal strength by adjusting the slug. Tuning is completed by the adjustment of C4, also for maximum signal strength.

26 Most RC noise filters show a fixed roll-off (slope) at frequencies above the cross-over frequency. Such filters with a single RC network usually have a 6 dB per octave roll-off.

Admittedly, with such filters, noise and high frequency distortion is made less obtrusive. However, not only the noise is effected, an important part of the high frequency content of the original signal may also have been wiped out. In such cases a filter with adjustable roll-off slope would be an asset.

Figure 2 shows a noise filter circuit with a cross-over frequency of approximately 7 kHz and a variable slope adjustable between 0 and approximately 25 dB/

25 A very convenient way of improving the performance of a not-so-sensitive FM tuner is the addition of a VHF pre-amplifier stage in front of the existing equipment. Satisfactory gain improvement can be obtained if the booster stage is designed using a

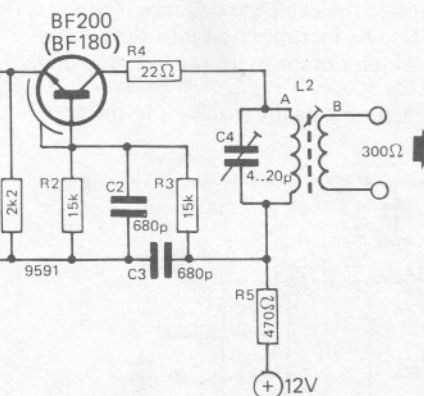

transistor having good VHF properties, such as the BF 200 or BF 180. These transistors also have good noise figures.

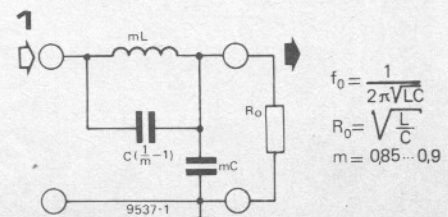

$$f_0 = \frac{1}{2\pi\sqrt{LC}}$$

$$R_0 = \sqrt{\frac{L}{C}}$$

$$m = 0.85 \dots 0.9$$

26 variable slope filter (cont.)

27 active oscilloscope probe

28 TTL-insurance (Norbert Conrads)

oct. The network, analogous to the cross-over filter in the Quad 33 pre-amplifier, is based on the m-derived low-pass filter (figure 1). The inductor is a Toko 33 mH 5% coil.

The frequency dependent characteristics of this filter are shown in figure 3.

Graph 1 represent a 0 dB/oct roll-off over the audio frequency range; this is with P1 shorting out the inductor.

Graph 2 shows a halfway position of the control, and graph 3 the effect of a maximum resistance across the inductor.

The equation of figure 1 will be of guidance to the constructor who wants to design a filter after his own taste using other inductances and/or cross-over frequencies.

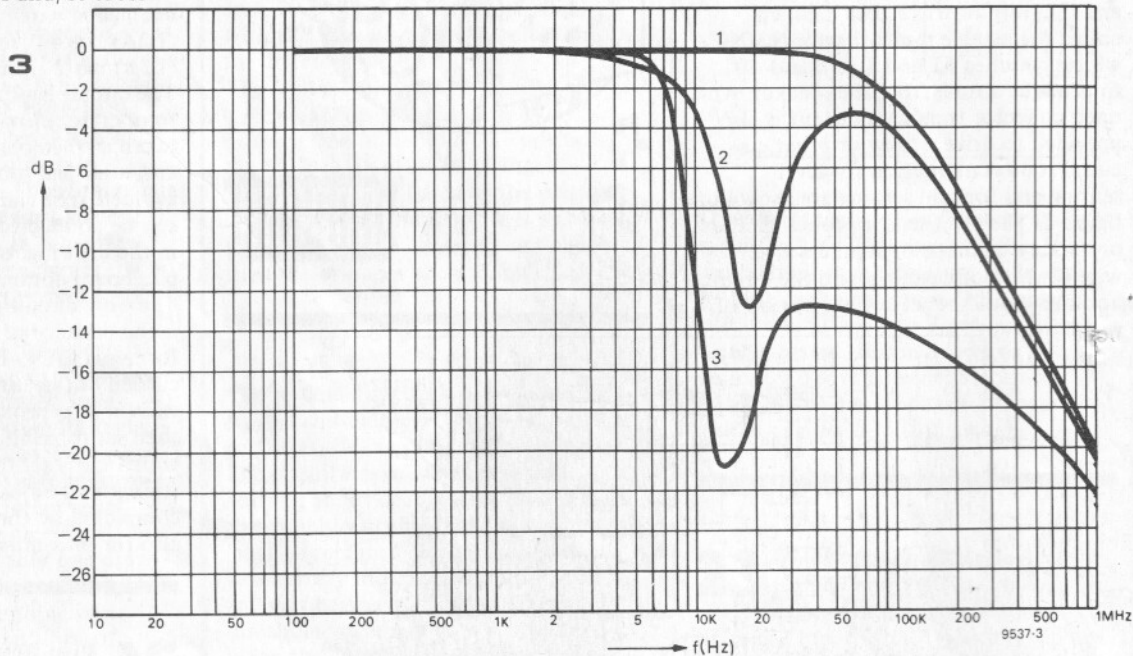
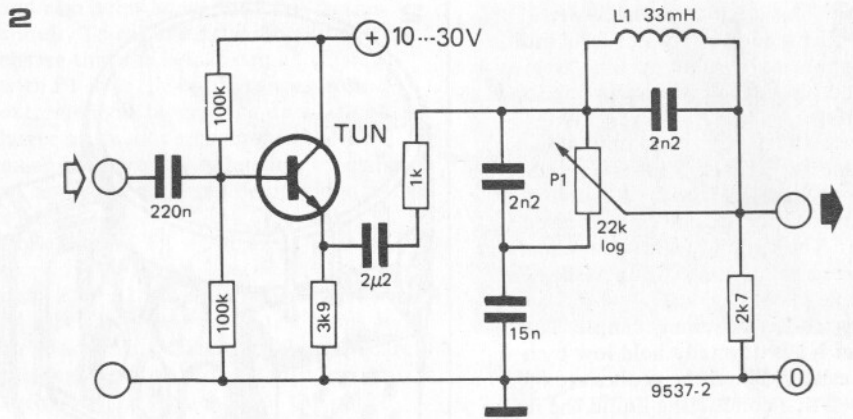

27 The vast majority of oscilloscopes possessed by home constructors have a fairly low bandwidth, between 3 and 10 MHz. On the most sensitive voltage ranges the bandwidth is often further reduced. The usual piece of screened lead (coax) with prods has a lot of capacitance. This is particularly noticeable when testing logic or other

pulse circuits, as this load capacitance can cause ringing. An active scope probe acts as an impedance converter. It presents a high input impedance to the circuit under test and has a low output impedance to drive the cable capacitance. Gain may also be incorporated into the probe, which can make up for lack of gain in the scope. A simple probe is shown in the ac-

companying circuit. A FET connected in source follower mode presents a high input impedance. This drives a bipolar transistor voltage amplifier. The upper frequency limit is approximately 30 MHz, provided sufficient care is taken with the construction. For high frequencies the lead must be correctly terminated at each end to minimise reflections.

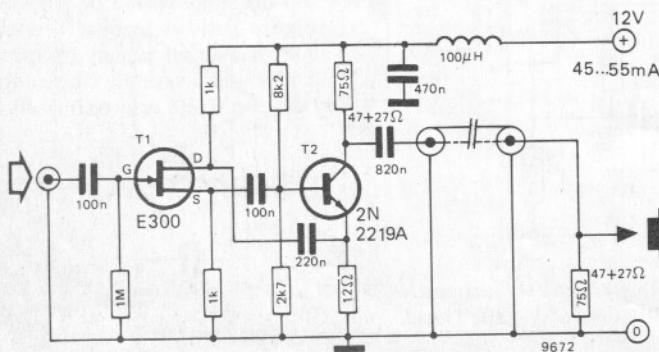

28 It still happens too often that a mains supply fails due to thermal overload. The result is usually a short circuit between collector and emitter of the output transistor. When this happens in a TTL-supply, the output voltage may reach an extremely high value, usually causing destruction of the TTL-ICs. The circuit described below prevents such disasters because it switches off the supply if the output voltage goes higher than 6 V.

29 simple headphone amplifier

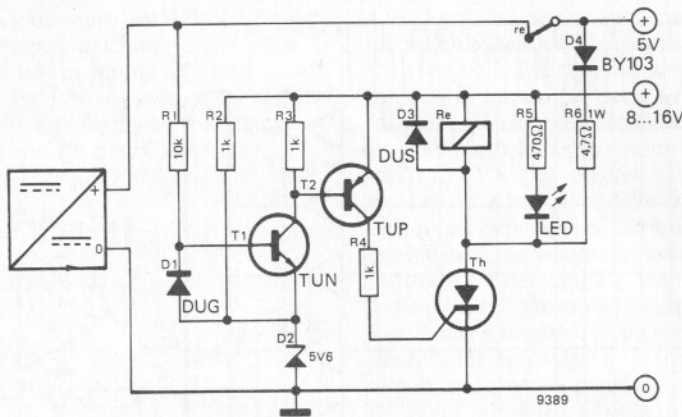

T1 functions as the voltage detector; via R2 and D2 the emitter of this transistor is held at a potential about equal to the TTL-supply voltage. If the base voltage now becomes about 0.7 V higher than the emitter voltage, T1 begins to conduct and triggers Th via T2 and R4. When the thyristor is triggered, relay Re is energized and cuts off the TTL-supply voltage. In addition a LED is connected parallel to the relay to give the user visual warning that the voltage is too high. Diode D1 limits the negative base/emitter voltage of T1 to a value of about 0.3 V. Furthermore, D4 and R6 in combination with the thyristor, create a heavy load for the TTL-voltage. Since a 'broken-down' supply is no longer stabilized, the TTL-voltage immediately drops to a safe value under influence of the additional load when the thyristor is triggered. Consequently, the response time of the relay does not play a significant part in this protective circuit. Diode D4 prevents interaction of the two supply voltages. The supply for the protective circuit (8...16 V) can be obtained from the non-stabilized out-

put (electrolytic smoothing capacitor) of the 5 V TTL-supply. The thyristor is reset by switching off the supply. Diode D4, shown as a BY103, can be replaced by any type that can handle at least 2 A. Thyristor Th must be a 3 Amp. type, and the operating voltage of relay Re should be about 10 V.

29 This headphone amplifier is intended for use with high impedance headphones (greater than 300 Ω) such as the Sennheiser HD414 and HD424. It is extremely simple and uses only two transistors per channel. The circuit comprises a voltage amplifier T1, driving an emitter follower T2, which provides the necessary low output impedance to drive the 'phones'. The circuit was intended to be driven by a control amplifier that can provide a nominal 1 V r.m.s. output, such as the TCA730/740 circuit published in Elektor 8. It was found that a gain of between 3 and 4 in the headphone amplifier would provide an adequate volume level in the headphones. The gain is determined by the ratio R3:R4 and is about 3.7. With such a small gain the distortion is fairly low due to the large amount of negative feedback at

the emitter of T1. The unbypassed emitter resistor R4 ensures that the impedance at the base of T1 is high (in fact $[1 + h_{FE} T_1]$ times R4) so the actual input impedance of the circuit is largely determined by the biasing resistors R1 and R2, and is greater than 40 k. The amplifier can thus be driven without difficulty by the control amplifier.

The output impedance of 6k8 at the collector of T1 is stepped down by the emitter follower T2, so that the headphones can be driven. The frequency response of the circuit is determined mainly by the input and output coupling capacitors C1 and C2 and is substantially flat between 20 Hz and 20 kHz. The nominal supply voltage of the circuit is 15 V but any supply voltage between 12 and 18 V may be used. The printed circuit board layout is arranged so that the input connections line up with the outputs on the TCA730/740 control board.

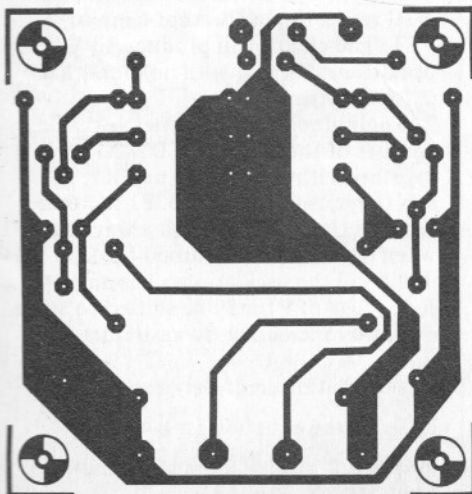
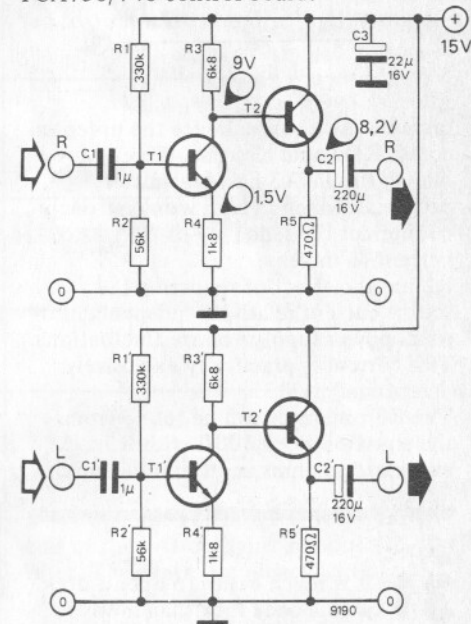

- Resistors:
 R1 = 330 k
 R2 = 56 k
 R3 = 6k8
 R4 = 1k8
 R5 = 470 Ω

- Capacitors:
 C1 = 1 μ
 C2 = 220 μ/16 V
 C3 = 22 μ/16 V

- Semiconductors:
 T1 = BC109C
 T2 = BC108B
 2 of each component
 for stereo, except C3.

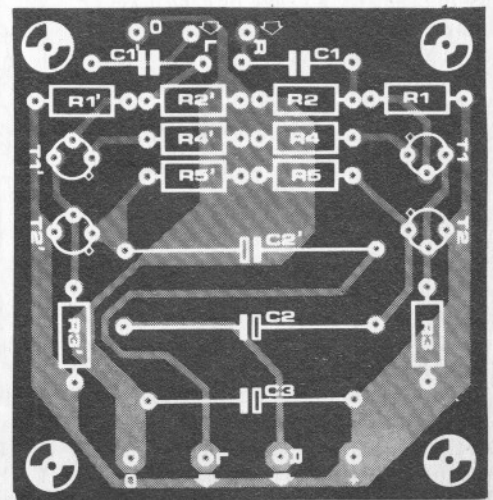

30 current source H. Frakstein

31 tapped code lock P. Cousin

32 wien bridge oscillator

30 This circuit features a Darlington pair T2/T3 joined by T1 to complete a negative feedback loop. This can be explained as follows.

Let it be assumed that, for one reason or another, the source current I has a tendency to increase. This would increase the potential across R3, causing the T1 base-to-emitter potential to rise and thereby the current through T1 to

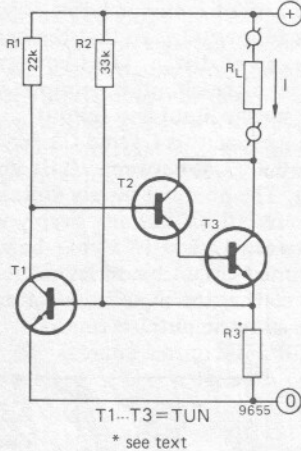

increase. As a consequence the potential across R1 would also rise, thereby reducing the T2/T3 base-to-emitter potential, which in turn would strongly counteract the tendency of the source current to increase.

R2 has the effect of rendering the source current relatively independent of small power supply voltage fluctuations. This current is practically exclusively determined by R3.

The R3 resistance can be found from the equation $R3 = 600/I$ with R3 expressed in ohms and I in milliamps.

31 It is much easier to open a door with a code lock than always having to carry a heavy bunch of keys about. Besides, keys can get lost, and code locks can't.

The diagram in figure 2 shows a code lock that can be opened with a simple three-digit code. However, this lock operates in a slightly unusual way. With this lock, three figures must be touched simultaneously (i.e. with three fingers). One finger in the wrong place, and the relay cannot be energized.

As figure 1 clearly shows, it is impossible to deduce from the lock's construction how it should be operated. This feature, together with the enormous number of possibilities, makes it impossible for an outsider to open the lock. The code for the example is 9-11-4. When this code is tapped, the inputs of N2, N3 and N4 become

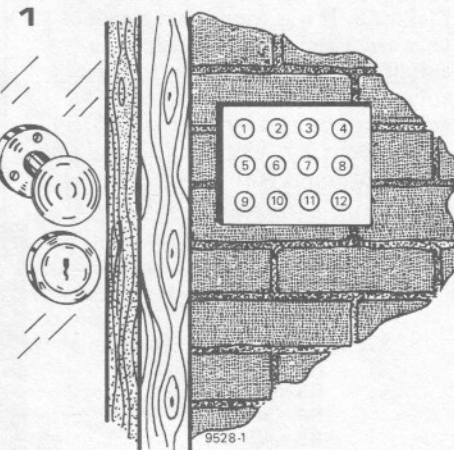
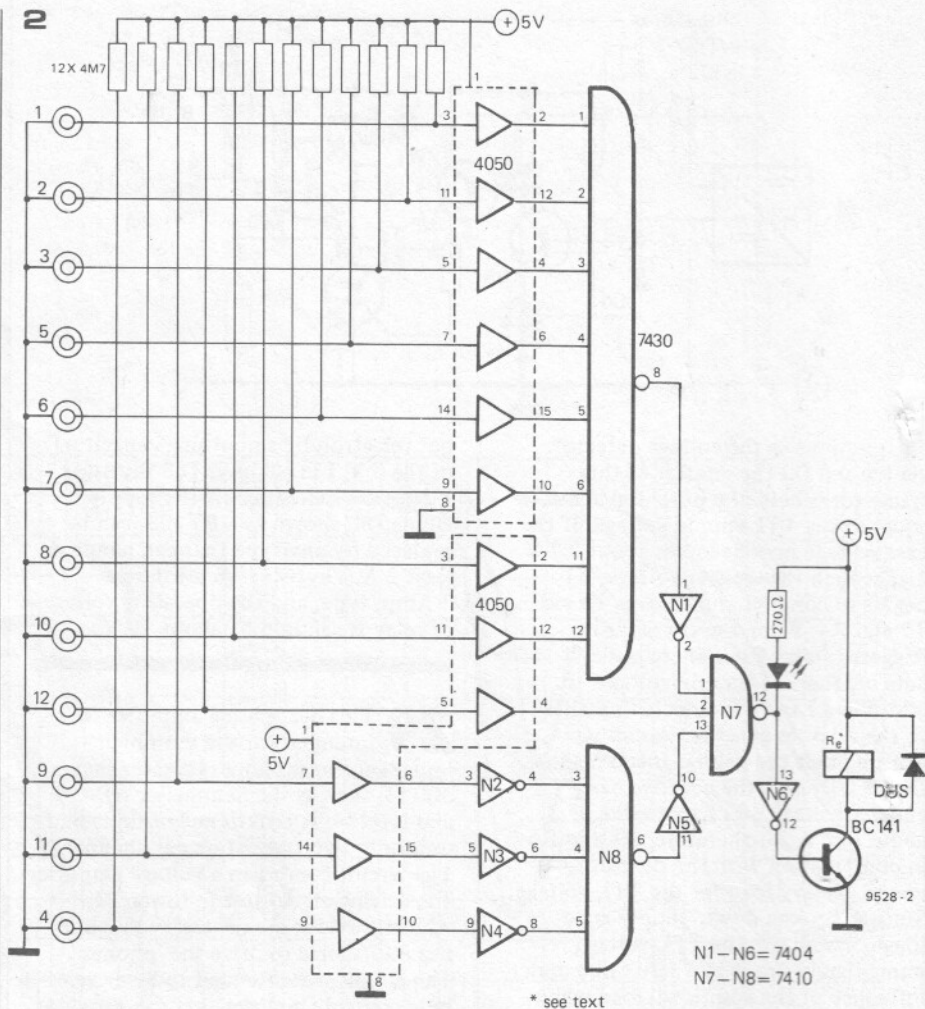

logic '0'; so, the three inputs of N8 and the output of N5 become logic '1'. If none of the other taps are touched, all inputs of N7 will be logic '1', which causes the relay to be energized and the LED to light up. The relay can be used to switch an electric door opener.

32 This oscillator uses a 741 opamp (or 1/4 of a LM 324) as its active component. It features an interesting and effective method to stabilise the output amplitude. A pair of reverse-parallel strapped diodes is used instead of the more conventional NTC resistor, incandescent lamp or FET. The circuit will produce 10 V peak-to-peak signal with no more than 0.2% distortion.

The amplitude stabilising network consists of the diode pair D1/D2 together with P1, R3, R4 and R7. P1 sets the output amplitude. P1 is connected into the circuit in such a way that when its resistance is turned too low it will kill the oscillations. The amplitude range of P1 may be shifted to some extent by increasing the resistance of R7.

The oscillation frequency can be found by using the equation $f = \frac{1}{2\pi RC}$ in which $R = R1 = R2 = 10 \text{ k}$, and $C = C1 = C2$.

33 porch lighter H.J. Wigbels

34 wind machine O. Corff

A frequency of approximately 1 kHz is obtained when C is 15 n. A balanced power supply of + and -15 V can be used in place of the single 30 V supply, in which case the voltage divider R5 and R6 plus C3 is not needed.

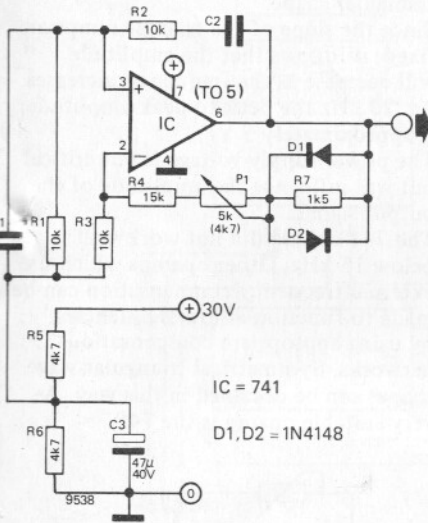

IC = 741
D1, D2 = 1N4148

470 Ω pot. An alternative arrangement would be to use a 6 V lamp in parallel with the bell. The only disadvantage is that it will burn out after a while. Initially, C1 charges through D1, R1 and the porch lamp to the zener voltage of Z1 (24 V). The resistance of the LDR in daylight is low, therefore the connection point between the LDR and P1 is held high. Even when the door bell button is pushed and T1 conducts, there is insufficient current to pull that point low. Since a negative pulse is needed by the SCS (at point Ag) to activate the circuit, nothing happens. However, when the LDR is in the dark it's resistance goes up, so that when T1 conducts the voltage drop at the anode gate (Ag) will be sufficient to trigger the SCS. When the SCS has been triggered, point Cg goes high, causing T2 to conduct which triggers the thyristor 'Th'. turning on the porch light. At the same time, C1 is discharging through the SCS and R5, R6 and R7. After about one minute, C1 has dis-

charged to such a low value, avout that of Z3, that the SCS stops conducting. The lamp is now switched off and the circuit then goes back to the quiescent state. C1 charges up and the circuit is ready for the next push of the button. The LDR must be mounted in a place so that it can detect day and night. Care should be taken so that outside lights (street lamps, passing cars) will not shine on it, otherwise the circuit may think it is daytime.

Warning: as mains voltages are present at many points in this circuit, caution must be taken. Use good insulation, especially at the opto coupler.

34 This circuit gives a true imitation of the sound of wind. Transistor T1 is connected as a zener diode and supplies T2 with a noise signal. This signal, amplified by T2, is fed to a selective amplifier built around

33 This circuit will automatically turn on the porch light when the door bell button is pushed, provided it's dark outside. After about one minute it turns the light off again. In the door bell circuit, when the bell-push S1 is closed, current flows through the two 1N4001 diodes (during alternate half cycles). The voltage across these two diodes is about 1.2 V, sufficient to light the LED in the optoisolator. LED current is adjusted by the

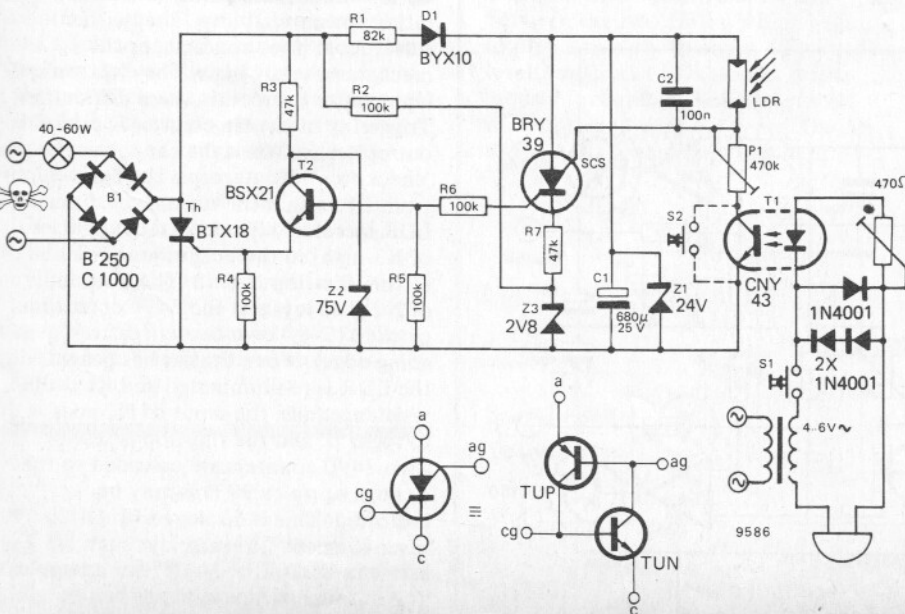
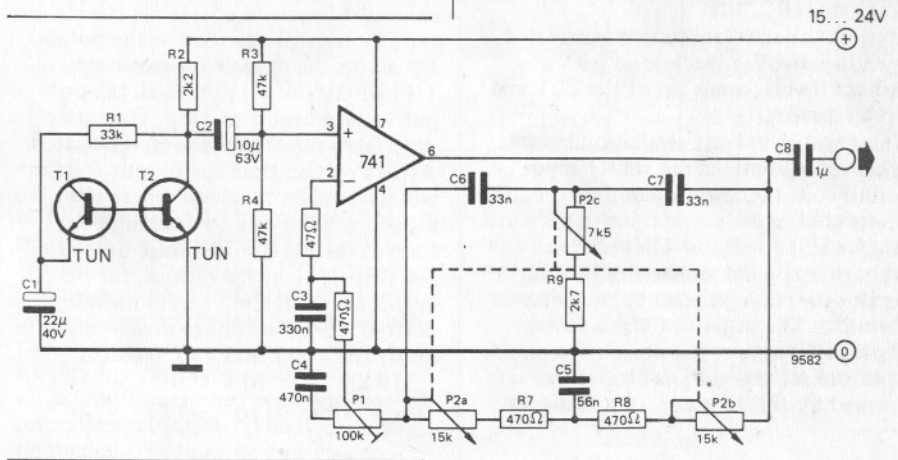

a 741 opamp. The negative feedback circuit of the 741 contains a double-T filter. The centre frequency of this filter, and thus the 'wind timbre' is adjusted with the three-section potentiometer P2a/P2b/P2c. Potentiometer P1 is for the wind force adjustment and can be provided with a Beaufort scale, if required. Potentiometer P2 can be made of a 15 k quadro pontentiometer, with two of the sections connected in parallel (P2c). If required, the component values in the double-T network can be modified to suit a different value for P2, according to the formula:

$$f = \frac{1}{2\pi RC}, \text{ with } R = P2a = P2b = 2P2c, \text{ and } C = \frac{1}{2}C5 = C6 = C7.$$

It is also possible to make P2 using three p.c.b. adjustment potentiometers mounted vertically and placed in line. Then some type of home made shaft can be slid through all three pots.

35 regulated + and - 15 V power supply

36 triangular wave oscillator

G. Bruggink

37 electronic lap counter

M. Hund

35 This compact balanced power supply makes use of the four opamps in a single 324 IC. They are used to stabilise the output voltage as well as limit the output current. The current limiter circuit is set at 60 mA and contains a minimum of components. It should be noted that under some conditions it may seem that the primary (input) power supply of only ± 16 V is on the low side. The maximum output voltage will depend on the properties of the IC which is used. It is NOT safe to increase the primary voltage; any increase may damage the chip.

A 5.6 V zener diode is used for the reference voltage. The zener voltage is not very critical; if low, the output voltage will be slightly low.

P1 is the voltage control for both the + and - supplies. Through it, the reference voltage is divided and applied to the + input terminal of the (top) opamp. This opamp regulates the positive output voltage by controlling the base current of the series regulating transistor (BC140).

Output voltage stabilisation is effected by a negative feedback loop with a voltage divider made up of the 22 k and 10 k resistors.

The negative voltage regulation is somewhat more complicated. The + input terminal of the lower opamp is connected to the zero potential terminal '0', via a 6k8 resistor. The reference voltage is applied via control P1 and some other components to the - input terminal. The negative output voltage is balanced against the positive reference potential by the voltage divider 'see-saw' formed by the 33 k and 10 k resistors

(which are bridged by a trimming network).

Trimming control P2 neutralises the influence of minor tolerances in the network components, and is adjusted to balance the positive and negative output voltages. Current protection is accomplished by the two remaining opamps in the IC. If the potential across either of the 10 ohm resistors exceeds 0.6 V, the reference voltage will drop to zero and, consequently, the output voltages with it. At the same time the LED's will light up to indicate that the protective circuit is operating.

36 A triangular wave generator can be designed and built with very few components, using an operational amplifier which has built in frequency compensation. The circuit was designed using the 741 opamp, however many other opamps will work.

When the power is switched on, the capacitor begins to charge via the variable resistor. As soon as the potential across the capacitor rises above 1/11 of the output potential, the output voltage begins to drop. The rate of drop (slew rate!) depends on the opamp. After a certain time the output voltage will have fallen to a level where the capacitor will begin to discharge. As soon as the capacitor voltage drops to less than 1/11 of the output, the output begins to rise again. The 1/11 level is derived from the voltage divider made up by the 100 k and 10 k resistors:

$$\frac{10\text{ k}}{10\text{ k} + 100\text{ k}} = \frac{10\text{ k}}{110\text{ k}} = \frac{1}{11}$$

With the design parameters indicated in the diagram the frequency can be set anywhere between 15 and 70 kHz. At 15 kHz the wave has a trapezoid shape with a peak-to-peak amplitude of approximately 25 V. At 20 kHz the output signal shows an excellent triangular shape.

Since the slope of the triangle ramps are fixed, it follows that the amplitude will decrease as the frequency increases. At 70 kHz the peak-to-peak amplitude is approximately 5 V.

The power supply voltage is not critical but will influence the amplitude of the output signal.

The 741 opamp did not work well below 15 kHz. Other opamps which use external frequency compensation can be made to function at low frequencies, by using appropriate compensation networks. Symmetrical triangular wave shapes can be obtained in this way. A very suitable opamp is the 748.

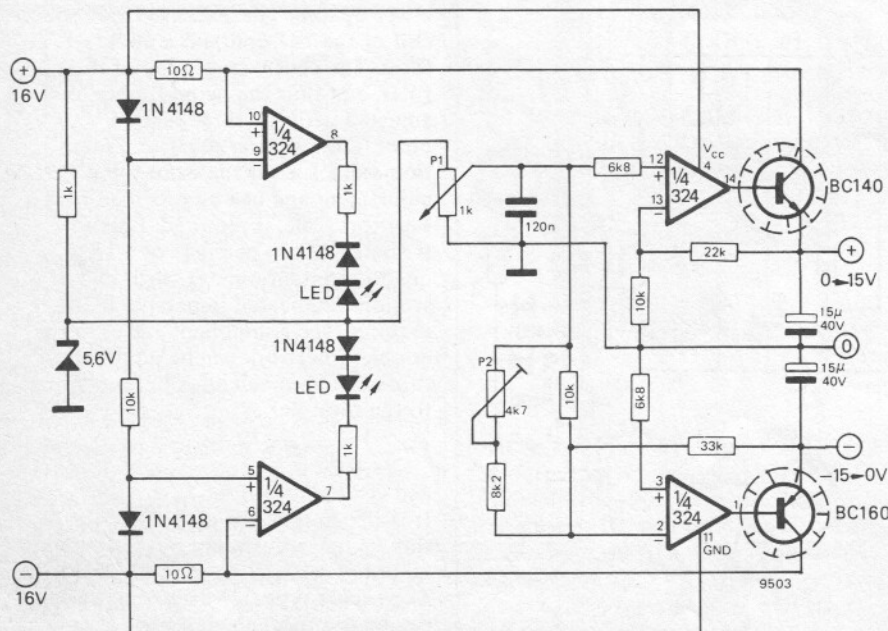
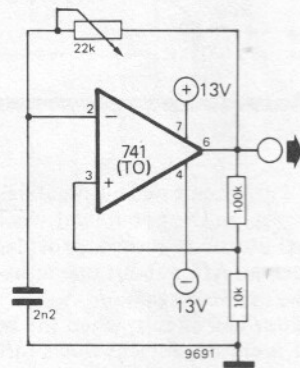

37 Mechanical lap counters for model racetracks have a reputation for unreliability. They either suffer from poor contacts, or the mechanism easily jams. The electronic lap counter overcomes these difficulties. Triggering of the lap counter is carried out optically. When the car passes the 'checkpoint' it interrupts the light from L1 so that the resistance of the LDR increases. This takes the input of N3 high, so the output goes low, setting flip-flop N1/N2. The output of N2 goes low and the 7490 counter is clocked (7490 counts on negative-going edge). When the car has passed, the LDR is re-illuminated and its resistance falls, the input of N2 goes to logic '0' and the flip-flop is reset. Two 7490 counters are cascaded so that a count of up to 99 laps may be indicated. This is displayed by two seven-segment LED displays such as Litronix DL707, or MAN7 for example. The number of laps in a race can be

38 opto coupler with two LEDs

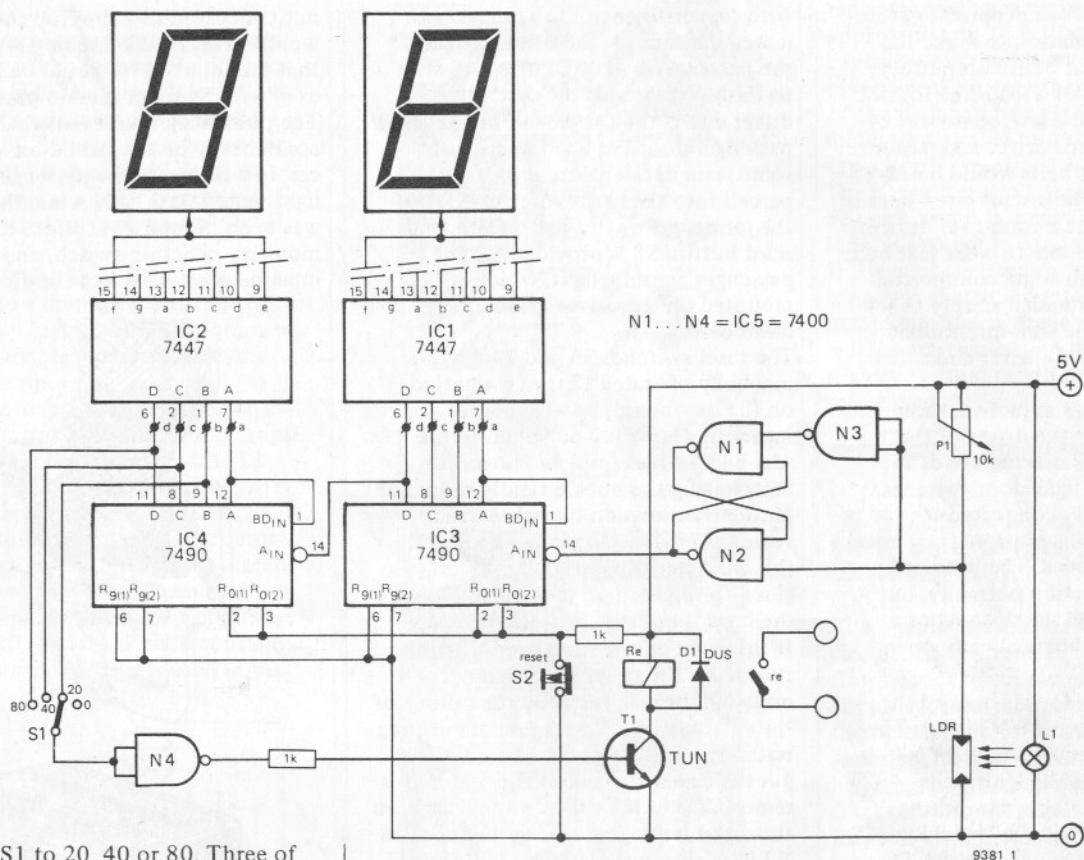

preset by S1 to 20, 40 or 80. Three of the positions of this switch are connected to the 2,4 and 8 outputs of the 10 lap counter IC4. The input of N4 is normally low so the output is high and T1 is turned on, energising relay Re. Power to the racetrack is supplied via the contacts of this relay. If the number of laps is set to say 40, then when the fortieth lap is completed the 'C' output of IC4 will go high. The output of N4 will thus go low, turning off T1 and opening the relay contacts, which cuts off the power to the track so that the car will stop. One lap counter is required for each lane of the racetrack and the relay contacts should be connected in series so that as soon as the first car completes the course power to the circuit is cut. Power can be restored and the counter reset by pressing the reset button S2. The LDR should be mounted in a cylindrical tube to screen it from ambient light, which might otherwise keep the LDR resistance low and block the circuit. The sensitivity may be adjusted by P1.

investigated. The diagram shows positive results. A logic level of at least 2 V is applied to the input of T1. The photo current generated in LED 2 is fed to a three-stage amplifier where it is brought to a level suitable to drive T5 and T6. At very low frequencies the duty cycle varies, but this forms no objection for most applications. The maximum frequency could not be determined owing to the capacitive cross talk between the two LEDs, which begins to play a role above about 40 kHz. The results with all LEDs are not unanimously favourable. The best results were obtained with HP types. Owing to the LED's selectivity as a light

sensitive diode, the system is hardly affected by ambient light. Only in a few exceptional cases will it be necessary to screen the LEDs against ambient light, particularly from fluorescent tubes.

R_x should be chosen according to the formula:

$$R_x = \frac{V_b}{I_{LED1 \text{ max.}}}$$

R_y represents the load resistor; for TTL applications, the supply should be 5 V and R_y is 270 Ω.

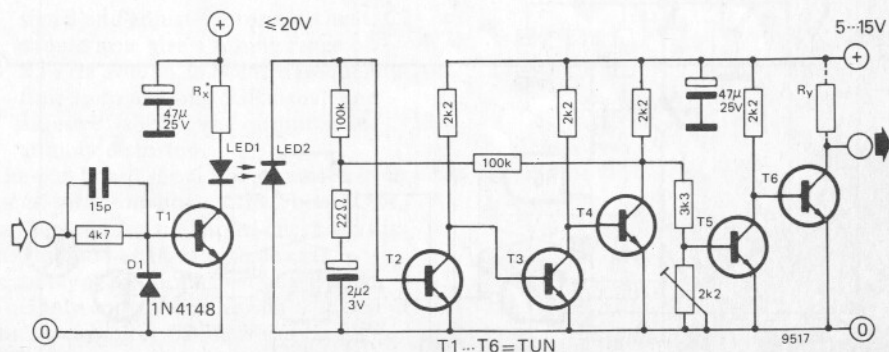

38 On the basis of the principle that the conversion of electrical energy to light in a LED must be reversible, its merits for practical use were

* see text

39 seat belt reminder

39 In view of the proposed government legislation to make the wearing of car seat belts compulsory, and the prospect of a £50 fine for not complying with the law, some sort of device that reminds driver and passenger to wear their seat belts would be extremely useful. The circuit given here is not intended to be a foolproof device for compelling people to wear seat belts (as is the case with some commercial systems) but is intended simply to jog the memory of the well-intentioned (but absent-minded) driver and passenger.

The circuit senses the fact that someone has entered either the driver or the passenger door by making use of the interior courtesy light door switches. These are normally connected in parallel, but for this purpose they must be isolated by diodes. The interior light will then still function normally, but it is possible to sense the opening of a door when the other is already open.

When the driver's door is opened the flip-flop comprising N1/N2 is set. The output of N1 takes the input of N4 high, so that when the ignition is switched on the astable comprising N3/N4 starts to oscillate, switching T1 and T2 on and off and flashing the warning light. When the door has been closed flip-flop N1/N2 may be reset by pressing the reset button S3, thus disabling the astable.

For the passenger door the same function is performed by N5/N6 and N7/N8,

with one difference. If the passenger leaves the car but the driver remains the passenger's warning light will start to flash. This is also the case if the driver enters the car alone but the passenger door has been opened at some time in the past e.g. to load parcels into the car before the start of the journey. For this reason a second reset button S5 is provided for the passenger warning light, which is mounted on the driver's side of the dashboard.

The reset switches S3 and S4 may be manually operated buttons mounted on the dashboard, or with a little ingenuity they may be linked to the seat belts. An example is shown for belts having the buckle rigidly mounted on the transmission tunnel. A reed switch is mounted on the buckle and this is activated by a small magnet glued to the hasp of the belt whenever the hasp is inserted into the buckle.

If this type of system is used then flip-flop N1/N2 may be dispensed with by omitting the link between the output of N1 and one input of N2 and connecting both inputs of N2 to S3 and R1. This has the advantage that if the seat belt is removed after the driver's door has been closed S3 will open, taking the input to N2 high. The output of N1 will thus also go high, enabling the astable multivibrator and flashing the driver's warning light.

It is not possible to do this on the passenger side however, because of the manual reset button S5. If N5/N6 were

not connected as a flip-flop then S5 would have to be a latching type so that the input of N6 could be held low even with S4 open (i.e. no passenger). The possibility then exists that S5 might accidentally be left closed on leaving the car, in which case the passenger warning light would flash only while the door was open. S5 must therefore be a momentary action switch, and N5/N6 must be connected as a flip-flop.

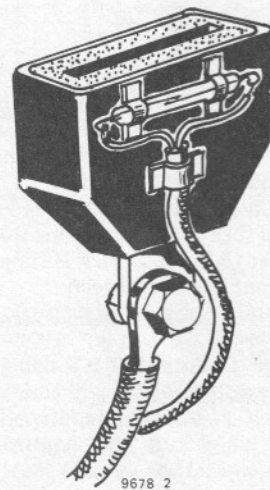
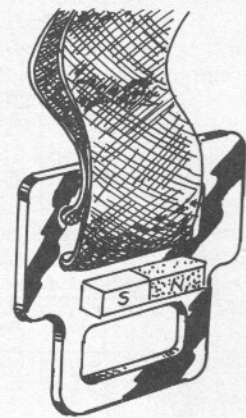

S1 = passenger's door
S2 = driver's door
S3 = driver reset
S4 = passenger reset
S5 = passenger override

N1 ... N4 = IC1 = 4011
N5 ... N8 = IC2 = 4011
D1 ... D2 = 1N4001
T1 ... T4 = TUN

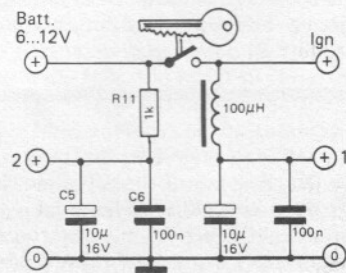
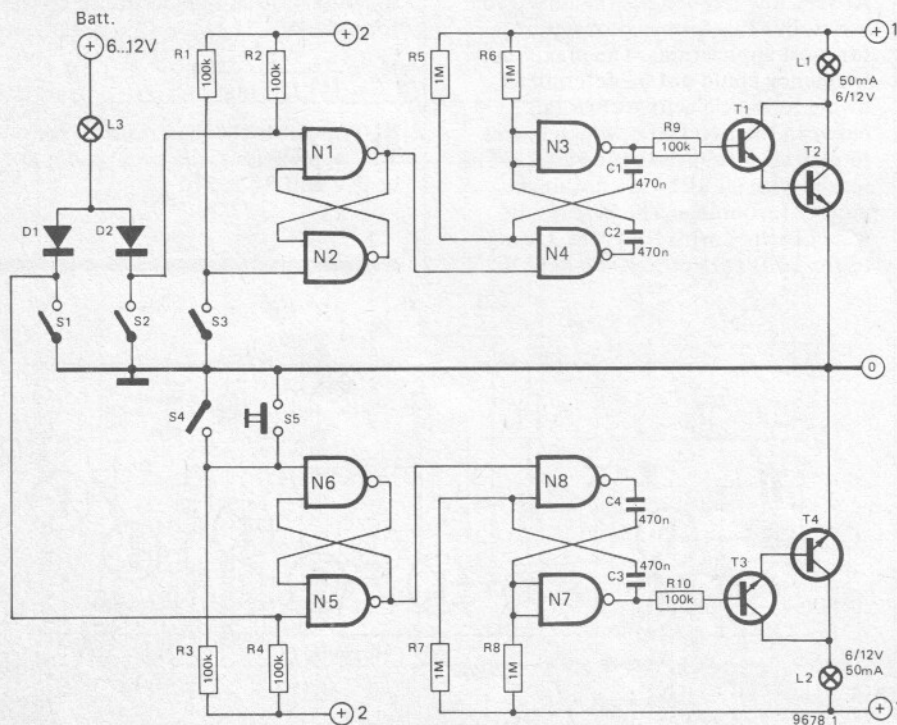

40 SSB adapter 41 microammeter

40 Several of the better portable radios have a number of short wave bands, with adequate stability for SSB (Single SideBand) reception. However, they are not provided with the necessary SSB detector, and very often the selectivity is also insufficient. A suitable extension circuit is required if one is interested in short-wave SSB reception.

In the circuit shown, a FET input stage (T1) is used so that the input impedance is sufficiently high to allow for connection of the adapter to practically any existing IF strip.

The limiting amplifier in IC1 is used as an oscillator, the high gain of this amplifier means that the tuned circuit (L1, C2...C4) need hardly be loaded, so that high stability of the oscillator can be achieved. Furthermore, the internal limiting stage in this amplifier is already designed to reduce the influence of supply voltage variations to a minimum. The TBA120 (or SO41P) also contains a multiplier stage, and this is used in this

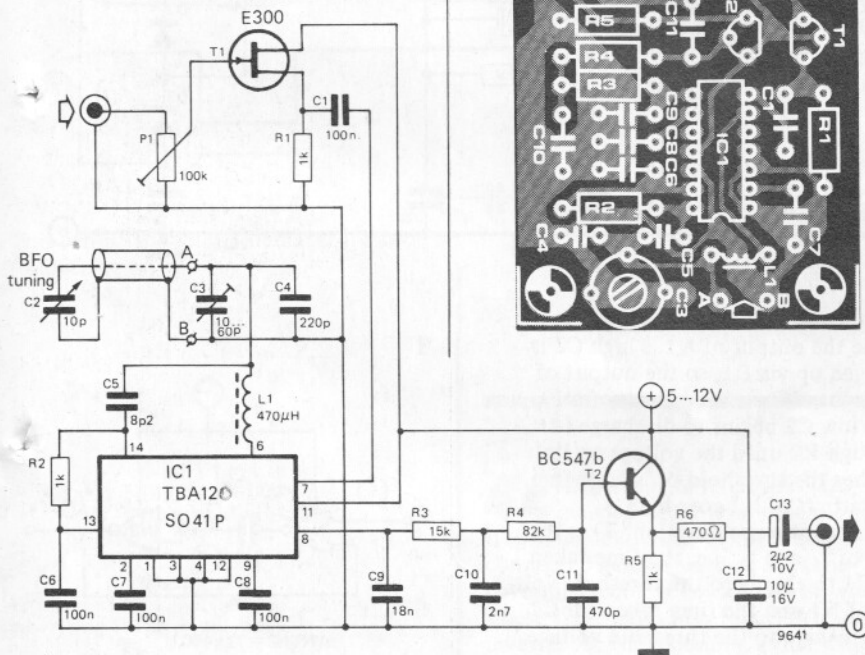
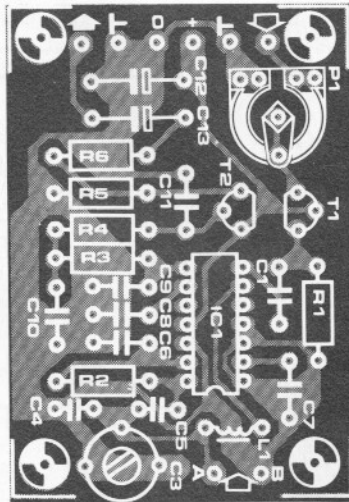
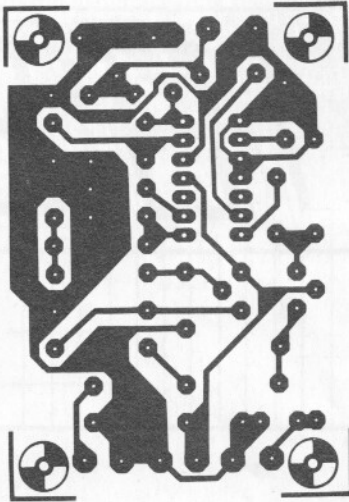

circuit as a product detector. To increase the selectivity, the output of this decoder is fed through a low-pass filter with a cut-off frequency of approximately 3.4 kHz (R1, R4, C9...C11). The output stage (T2) is simply an emitter-follower; it can drive practically any headphone direct. The alignment procedure is relatively simple:

- set C2 in its mid position;
- using C3, set the oscillator frequency to match the original IF frequency (455 kHz). This can be done with a frequency counter, if one is available; failing this, tune in to a normal AM

signal and adjust C3 for zero beat. C2 should now give a tuning range of ± 3 kHz around the centre frequency. - tune in to a strong SSB signal, and adjust P1 so that the output is not audibly distorted.

The p.c. board should be mounted in a metal screening box. A BNC connector can be used for the input; check that it makes good contact with chassis, certainly if an aluminium box is used. The only control on the box is the BFO tuning capacitor C3. This can be connected to the p.c. board using screened cable. The actual value of C3 is not so critical, provided it gives a total tuning

range (capacitance variation) of approximately 10 p. If the only tuning capacitor obtainable is too large, it is always possible to either strip out some of the plates to bring it into the required range, or else add a small series capacitor.

The connection to the receiver should be coax, and not more than 3' (1 m) long. It should be connected to the final IF stage of the receiver via a 10 p capacitor that is mounted as close as possible to the IF stage in question. This will, of course, detune the final IF stage slightly, so that it will have to be retrimmed.

41 This circuit can be used for current measurements in five ranges, from 1 μ A to 10 mA f.s.d. (D.C.).

The opamp is used in a virtual earth circuit. The current I_x to be measured flows direct to supply common, and the circuit supplies an equal current from the opamp output through the corresponding feedback resistor to the inverting input terminal; the polarity of this current is indicated in the diagram. Inspection of the circuit reveals that I_x is supplied by the opamp output circuit. Since the inverting input terminal remains at earth potential (this is what 'virtual earth' is all about!), the opamp output terminal will be positive with respect to zero; the voltage at f.s.d. will be 1 V for the feedback resistance values indicated in the diagram.

The resistance of the meter plus the series resistor R must give full scale deflection at 1 V. With, for instance, a meter of 1 mA f.s.d. the sum of the resistances must be 1 k Ω ; for a 100 μ A meter the sum must be 10 k Ω , and so on. A preset potentiometer can be used for R.

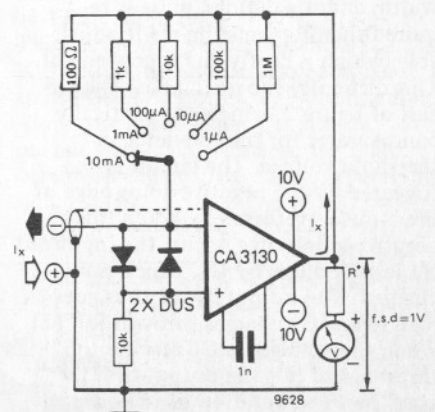

42 perpetual solar clock

43 MOS monostable

42 Using a modern CMOS watch chip driving a Liquid Crystal display, it is a perfectly feasible to construct a perpetual clock that will obtain its power from the sun. The only components that may eventually fail are the LC display and the NiCad batteries used to power the clock during darkness. The solar power supply is extremely simple. 5 silicon solar cells provide about 2.75 volts in bright sunlight, slightly less in average artificial lighting, which powers the clock and charges the batteries. The two diodes drop the 2.44 volts of the NiCad battery down to about 1.6 V which is the voltage from which the clock IC operates. (Suitable solar cells cost about 70 p each.)

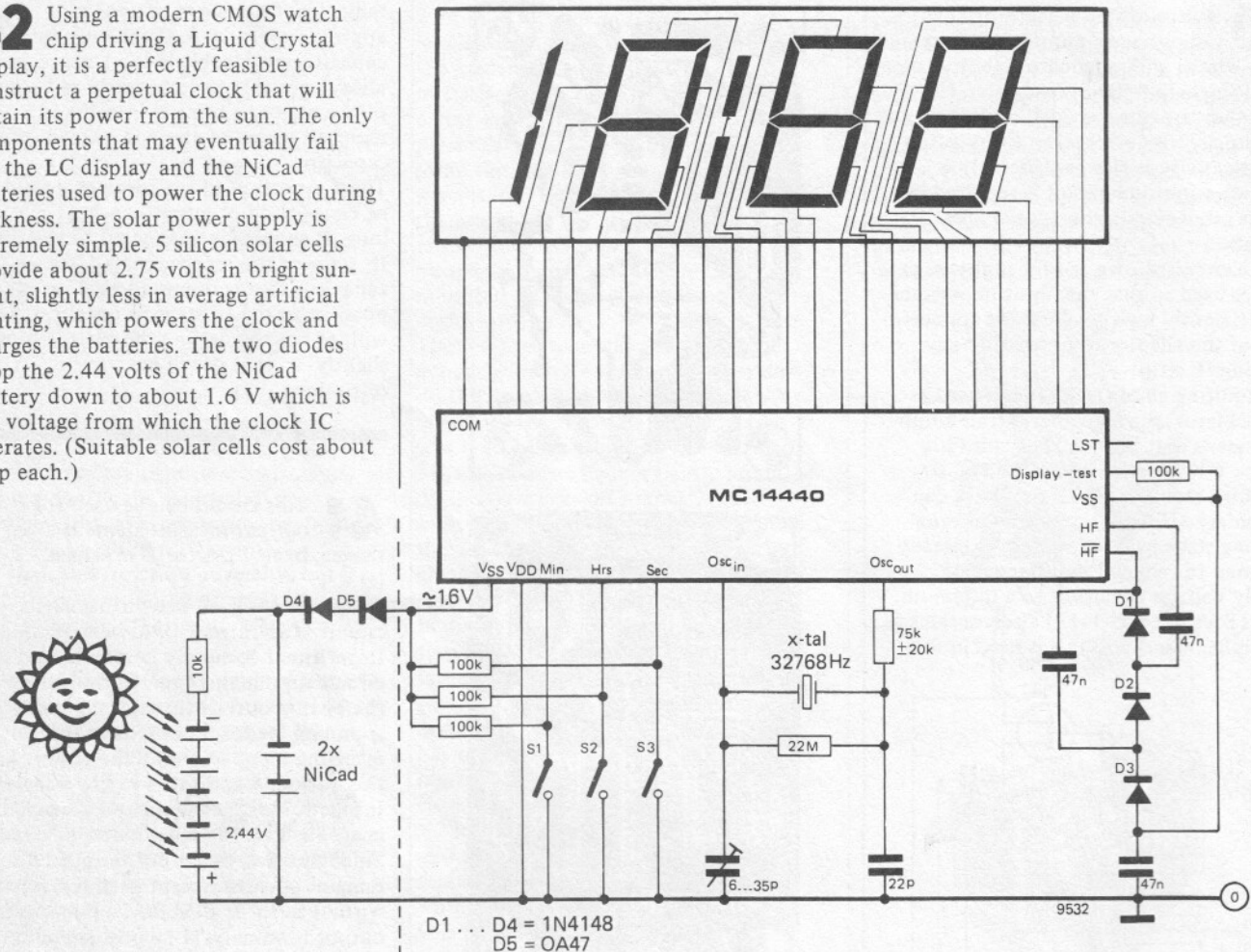

43 The basic circuit of a monostable using CMOS NOR-gates is given in figure 1. The disadvantage of this simple circuit is that the output pulse width depends not only on the time constant $R_T C_T$, but also on the switching threshold of the output inverter N2. As this is subject to a $\pm 33\%$ manufacturing tolerance it is not possible to accurately determine the pulse width, and if a defined pulse is required then R_T must be made adjustable, which is costly and inconvenient. This difficulty is overcome by the circuit of figure 2, which automatically compensates for the tolerance in threshold voltage. The circuit is triggered by the negative-going edge of the input waveform (1). When this negative-going edge occurs the input of N1 is pulled low by C1, which is uncharged. The output of N1 thus goes high, while C1 charges through R1. (2) When the voltage on C1 reaches the threshold of N1, the output of N1 goes low. The duration of the output pulse from N1 (3) is denoted by t_1 .

While the output of N1 is high C2 is charged up via D1, so the output of N2 is low. When the output of N1 goes low C2 begins to discharge (4) through R2 until the voltage on it reaches the threshold of N2, when the output of N2 goes high. The output pulse duration (T) is the sum of t_1 and t_2 , i.e. the time taken for C1 to charge to the threshold voltage of N1 and the time taken for C2 to discharge to the threshold voltage of N2, respectively.

The compensation of the output pulse length depends on the fact that two gates fabricated on the same chip usually have equal threshold voltages, so it will work only if N1 and N2 are in the same package. The compensation operates as follows: if the threshold voltage is the nominal value (approx 45% supply voltage) then, assuming that the time constants $R_1 \cdot C_1$ and $R_2 \cdot C_2$ are equal, it will take approximately the same time for C1 to charge to the threshold voltage of N1 as it takes C2 to discharge to the threshold voltage of N2. If the threshold voltages are higher than nominal it will

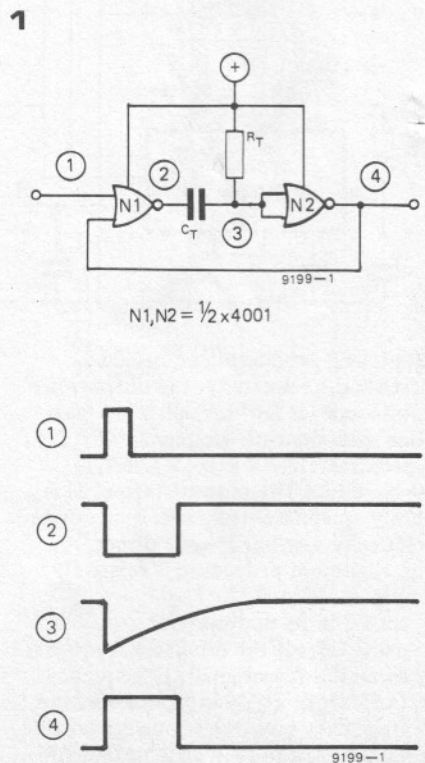

44 spike monoflop

take C1 longer to charge to the threshold voltage, but it will take C2 a shorter time to discharge to the threshold voltage. If the threshold voltages are lower than nominal it will take C1 a shorter time to charge, but C2 a longer time to discharge. The net result is that the overall pulse length stays more or less constant.

With the manufacturing tolerance on V_t , k can vary between 0.33 and 0.66, but this will cause only an 8.5% variation in the monostable output pulse width. With the nominal value of threshold voltage the pulse length is approximately 1.4 RC.

Literature:
RCA Application Notes

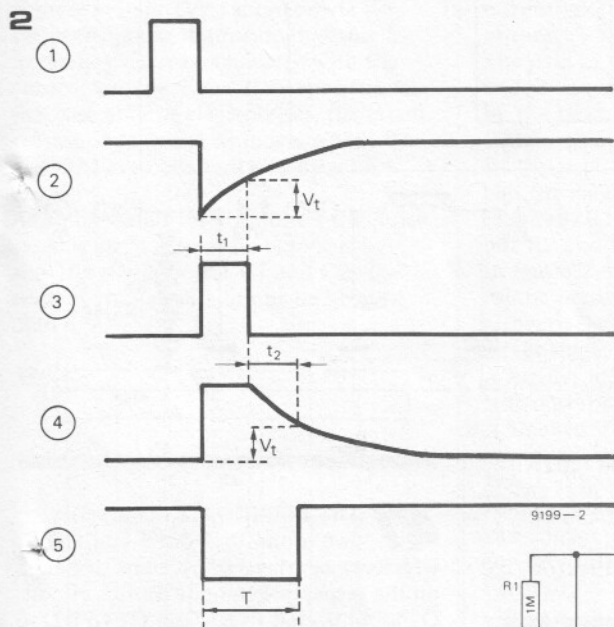

This can be shown mathematically as follows:

$$T = t_1 + t_2$$

$$t_1 = R \cdot C \cdot \ln \frac{V_b}{V_b - V_t}$$

$$t_2 = R \cdot C \cdot \ln \frac{V_b}{V_t}$$

where V_b = supply voltage
 V_t = threshold voltage

$$C = C_1 = C_2$$

$$R = R_1 = R_2$$

rewriting these equations

$$t_1 = R \cdot C \cdot \ln \frac{1}{1 - k}$$

$$\text{and } t_2 = R \cdot C \cdot \ln \frac{1}{k}$$

$$\text{where } k = \frac{V_t}{V_b}$$

therefore

$$T = R \cdot C \cdot \ln \frac{1}{1 - k} + R \cdot C \cdot \ln \frac{1}{k}$$

which simplifies to

$$T = R \cdot C \cdot \ln \frac{1}{(1 - k)k}$$

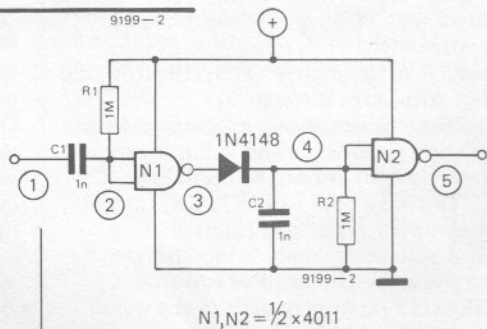

44 Only four NAND-gates are needed to build a spike monoflop. The delay time of three series-connected gates is used as the time-governing element (output pulse width). These three gates also function as an inverter for the incoming signal. During static conditions when the input signal is either '0' or '1' the gate N4 receives input signals which are not the same. This means the NAND output will be high (1). Understanding the static condition of this circuit is simple, however for dynamic conditions it is best to think

of the input signal as a 'wave front' rather than just levels. This wave front passes through two different circuit paths. One path is direct to N4 and the other is through the delaying inverter N1...N3 then to N4. Since one wave front arrives slightly before the other it is only during this short time that the output of gate N4 will change state. Furthermore, this only occurs during positive going input transitions: if the input signal was low, the inputs to N4 would be '0' and '1' (top to bottom); when the input changes to '1' the top input to N4 changes instantaneously. This makes the inputs to N4 '1' and '1' which gives a '0' at the output. The output will remain at '0' as long as the wave front is moving through the delay gates, the typical propagation delay for each gate is 11 ns. Therefore the output pulse is only about 30 ns. A negative going input transition will not produce an output pulse: at the moment the input goes '0' the inputs to N4 are '0' and '0' which still gives a '1' at the output.

If a positive going spike is need at the output, an inverting transistor stage can

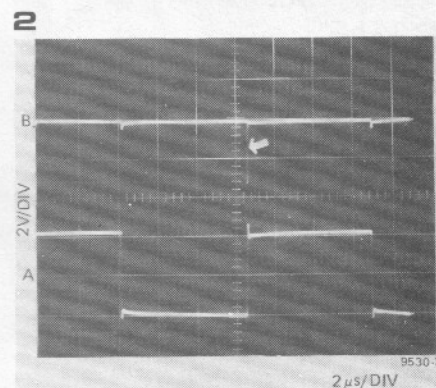

be added. The use of TTL inverters is not a good idea, because there is a good chance they will not respond to such short spikes (30 ns). To increase the pulse width, five gates could be connected in series to form the delaying inverter, which would make a pulse width of about 50 ns. This pulse should be TTL compatible.

The circuit was tried using the TTL IC 7400, but it should also be possible to use COSMOS gates. The photograph shows the input signal (A) and the output signal (B). The negative spike occurs on the positive edge of the input signal.

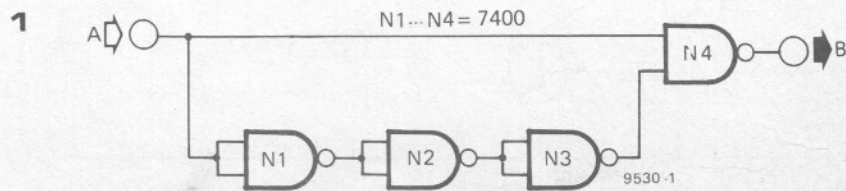

45 ignition key reminder

46 car clock using watch IC

47 VCO with 74123

45 This circuit is intended to prevent a car driver inadvertently leaving the ignition key in the lock. It will provide a warning if the driver attempts to leave the car while the ignition key is still in the lock, whether the ignition is switched on or off. The fact that the key is in the lock with the ignition switched off is detected by a light source and sensor arrangement. When the car door is opened the interior courtesy light switch will close and L1, which is wired into the same circuit, will light. T3 will be turned off and one input of N1 will go high. If the key is not in the lock then the phototransistor T2 will receive light from L1 and the other input of N1 will be held low. If the key is in the lock with the ignition off the light from L1 will be blocked by the key and the input of N1 will be high by R2. The output of N1 will be low so the output of N2 will be high and the multivibrator comprising N3/N4 will start. Similarly, if the ignition is turned on when the door is opened T1 will be turned on, holding the input of N1 high, and the alarm will sound.

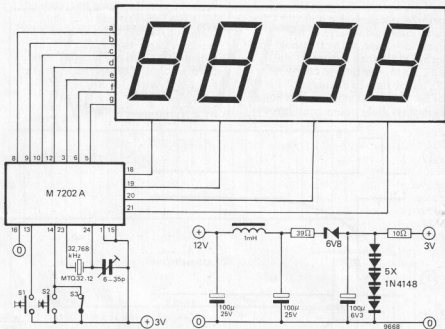

46 Using the Intersil ICM7202A (new version of the 7202) an extremely compact car clock can be constructed. The circuit is basically similar to the digital watch (Elektron 10), but with three differences.

1. The display runs continuously. This is quite permissible and will not exceed the power or current ratings of the IC.
2. The p.c. board can be larger, thus making for easier construction.
3. A stabilised supply is incorporated to allow the circuit to be run from 12 V. The DL34M display used in the watch circuit should be quite visible even when mounted on a car dashboard. (Anyone who can't read it shouldn't be driving!)

The master control S3 is normally closed so the display is on continuously.

47 The TTL-IC 74123 comprises two monoflops (MF1 and MF2) which can be triggered by a positive edge on the respective B-input. In this circuit Q2 is connected to B1, and Q1 to B2; so the two monoflops MF1 and MF2 together form an astable multivibrator. The cycle time is determined by the sum of the pulse times of the monoflops.

2

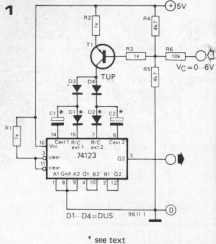
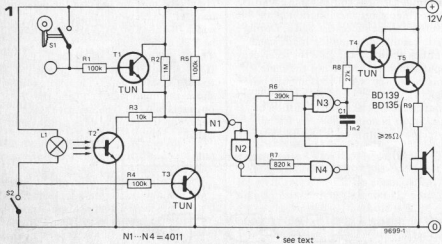
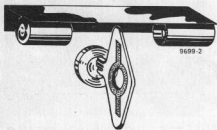

Normally, the pulse times of the monoflops are determined by an external capacitor (between the points 14/15 and 6/7, respectively) in combination with an external resistor (between the points 15 and positive supply, and 7 and positive supply). This standard configuration has been

48 three channel mixer

49 tap doorbell

B. Segor

changed in so far that the diodes D1 and D2 have been added. This is important when electrolytic capacitors are used for C1 and C2. Furthermore, the external resistors are replaced by the current source transistor T1. The charge times for C1 and C2, respectively, are now determined by the collector current of T1 which in turn is determined by the control voltage (V_C) supplied via R6. From the graph it appears that the frequency decreases linearly with the control voltage. Since the capacitors in this case are not electrolytics, the graph corresponds to the situation where D1 and D2 have been replaced by wire links.

At equal values for C1 and C2 the duty cycle is 50%. Any value between 1 n and 100 μ will do for C1 and C2. The control voltage should not be higher than 6 V.

considered as current-driven instead of voltage-driven. For this reason resistors must be included in series with each input. This type of opamp is ideal for virtual earth mixer circuits (figure 1). An obvious application is to use three of the four opamps in one IC as input preamps (A1, A2 and A3 in figure 2), and to use the fourth as a summing output buffer stage, i.e. the mixer proper.

The gain of the basic virtual earth circuit shown in figure 1 is determined by the ratio of the two resistors R1 and R2. Furthermore, to obtain a correct DC balance, the value of R3 should be half the value of R2. If variable gain is required, R1 should be made variable but R2 and R3 remain fixed.

In figure 2, the gain of the input stages can be preset with P4, P5 and P6 respectively; P7 sets the gain of the mixer stage.

A further interesting feature of a Norton-type opamp is that the amplifier is blocked if the non-inverting input is grounded; the output voltage is then practically equal to the positive supply voltage. This means that switches S1, S2 and S3 can be used to completely block any unwanted input, reducing noise and crosstalk.

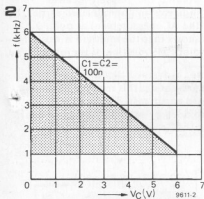

48 The LM3900 and the CA3401 are both quad Norton-type opamps; the inputs can best be con-

49 A reliable tap doorbell can be built using a few cheap components, which usually can be found in the junk-box.

In the circuit described here the touch contact (tap) is connected to the base of T1. When a finger is placed on the TAP, mains hum on the skin will drive T1. This changes the bias on the base of T2, which in-turn drives the darlington T3/T4, switching on the buzzer and the lamp. A small piece of printed circuit board, aluminium foil or something similar can be used for the TAP contact. T1 must be mounted very close to the TAP or the connecting wire will pick up too much hum.

In the quiescent state the circuit draws about 4 mA. It will work on any supply voltage from 6 to 12 volt. Of course the buzzer and lamp must be suitable for the supply voltage which will be used.

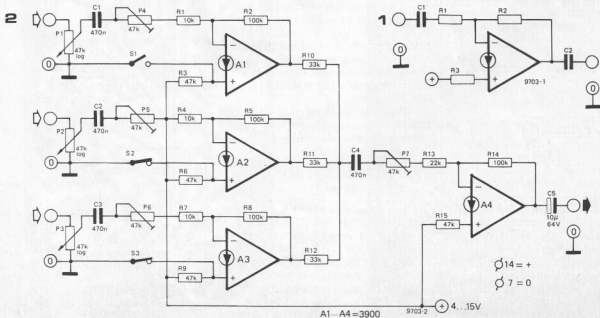
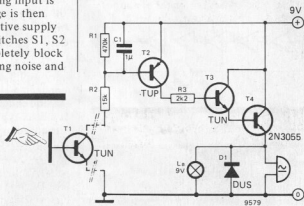

A1 - A4 = 3900 9702-2 + .15V

50 AMV without R and C

51 aircraft communication receiver

50 This astable multivibrator is built from an odd number of inverters. These inverters can be either TTL or COSMOS. The frequency of oscillation depends on the total propagation delay time of the inverters. The oscillation is the result of circulating inverted pulses. The cycle time of the square wave voltage equals twice the total propagation delay time. The frequency can be calculated by using:

$$f = \frac{1}{2 \cdot n \cdot T_p}$$

where f = oscillating frequency
 n = number of inverters (odd)
 T_p = propagation delay time (per gate)

If the circuit was built using 5 TTL inverters such as a 7404, the propagation delay time would be 10 ns per gate. The resultant frequency would be:

$$f = \frac{1}{2 \times 5 \times 10^{-8}} = 10 \text{ MHz}$$

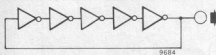

51 The simplest VHF receiver is the superregenerative.

Unfortunately, it is also one of the most difficult to get working properly . . .

Most of the problems stem from the fact that the oscillator is self-quenching.

The receiver described here is less critical than the conventional superregen, but it also uses more components: the various superregen functions are each performed in separate stages.

The first stage (T1) is an RF preamplifier. The input (aerial) is not tuned, both in the interest of a simple alignment procedure and to reduce the danger of feedback from the oscillator to the RF input.

The LC tuned circuit at the collector of T1 doubles as the tuned circuit for the oscillator. The oscillator stage (T2) is operated in a grounded base configuration. A multivibrator (T3 and T4) supplies a quench signal which turns the oscillator on and off. For proper operation of the circuit, either the turn-on or turn-off must be exponential; in this design, the turn-off was made exponential.

The quench voltage at the oscillator output is passed through an RC filter network (C7, C9-C12, R9-R14, T6); the remaining (audio) signal is amplified by

T7 and T8 to a sufficient level to drive a crystal earphone or audio amplifier. The measurement results on the prototype were as follows:

- sensitivity: 2 μ V for 12 dB S/N;
- bandwidth: 1 . . . 10% of the centre frequency, depending on the input signal level;
- audio output level: 50 mV . . . 2 V (p-p);
- quench frequency: \geq 30 kHz (depending on supply voltage);
- type of detection: logarithmic law, i.e. the audio output level is almost independent of the RF input level;
- residual quench voltage at the output: \leq 50 mV (p-p);
- tuning range: 90 . . . 180 MHz.

Construction details

The p.c. board (and, if required, a 4.5 or 9 V dry battery) should be mounted in a metal box. The tuning capacitor should be mounted in such a way that the wires connecting it to the p.c. board are not longer than half an inch (1 cm). Note that the connection to the rotating vanes must also be connected to the p.c. board — the capacitor will not work very well if only one side is connected . . .

A good choice for the aerial input socket is a coax-type UHF connector. This has the advantage that a 'banana plug' fits into it perfectly. The aerial can now be made of a large metal knitting needle (about 15 inches long), soldered into the banana plug.

If an aluminium box is used, make sure that all panels make good contact to each other and to supply common — check this with an ohmmeter. When the receiver is switched on, a loud hissing should be audible. Set P1 for maximum hiss level. It should now be possible to tune in to several transmitters, certainly in the VHF FM band. The aircraft communications are concentrated around 123 MHz and 137 MHz.

If no stations can be received, something is wrong with the receiver. The following trouble-shooting procedure should be carried out:

1. Turn the slider of P1 up to the R5 end (shorting out P1).
2. Tune a portable VHF-FM receiver to approximately 100 MHz, hold its whip aerial about an inch away from the oscillator coil L1, and turn C3 slowly. If the portable FM receiver suddenly starts to hiss loudly, the oscillator and quench generator of the aircraft receiver are working properly. If an unmodulated carrier

is found instead of hiss (the portable receiver goes quiet instead of hissing loudly), this means that the quench multivibrator T3/T4 is not working properly. An AC voltmeter can be connected via a capacitor to point 'X' to check this.

3. If the above measurements did not locate the fault, the next step is to check the audio stages. The voltages at points B and D should be $\frac{1}{3}V_b - 1$ volt and $\frac{1}{2}V_b$ respectively.
4. The RF amplifier stage can be checked by measuring the emitter-base voltage of T1 (0.2 V); the voltage at point A should be $\frac{1}{2}V_b + 0.2$ V.
5. If the oscillator and the quench multivibrator are both working — see point 2, the portable receiver indicates an unmodulated carrier, but the AC measurement at point X shows that the multivibrator is working — diode D5 must be of the wrong type.

Note: be warned that under no circumstances should this receiver be used on board an aircraft. This is strictly forbidden by international agreement, and the penalties are very high!

Resistors:

R1 = 4k7
 R2,R3,R4,R6,R7 = 10 k
 R5 = 470 Ω
 R8 = 27 k
 R9 = 220 k
 R10 = 470 k
 R11,R12,R13,R14 = 33 k
 R15 = 2k2
 R16,R19,R20,R27 = 1 k
 R17,R18,R22 = 47 k
 R21 = 22 k
 R23 = 100 k
 R24,R25 = 3k3
 R26 = 33 Ω

Semiconductors:

T1 = AF239
 T2 = BF199
 T3,T4,T6,T7 = BC547, BC147
 T5,T8 = BC557, BC157
 D1 . . . D5 = 1N4148

Capacitors:

C1 = 47 p
 C2,C4 = 820 p
 C3 = 2 . . . 20 p, tuning capacitor
 C5 = 22 μ /3 V
 C6 = 2p2
 C7 = 12 n
 C8 = 680 p
 C9,C10,C11,C12,C22 = 1n5
 C13,C14 = 470 p
 C15,C18,C21 = 100 n
 C16 = 47 n
 C17 = 10 n
 C19 = 47 μ /10 V
 C20 = 470 μ /10 V

$A = \frac{V_b}{2} + 0.2$
 $B = \frac{V_b}{3} - 1$
 $C = 0.5 \dots 0.7$
 $D = \frac{V_b}{2}$

L1 = 2.5 turns 1 mm Cu ϕ = 6 mm

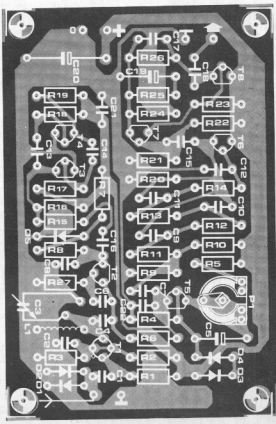
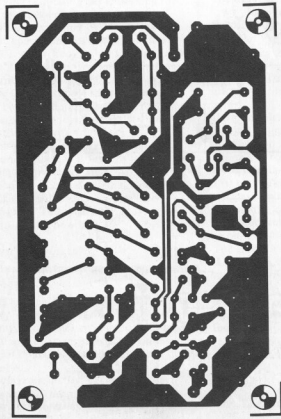
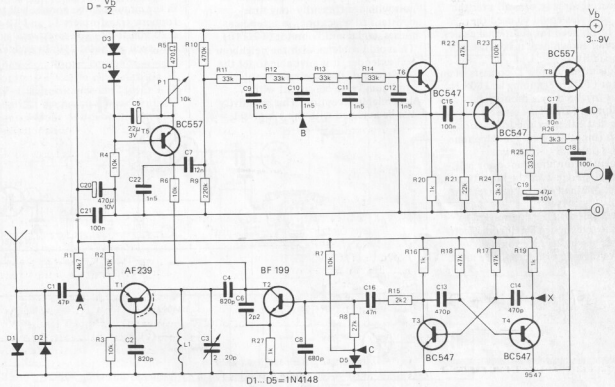

52 'wireless' bell extender

52 The front-door bell or telephone cannot always be heard all over the house. Extending the bell usually means running wires all over the house, which is not a particularly elegant solution to the problem. However, the mains wiring already runs all over the house, so if this could be used there would be no need for additional cables. The circuit shown here makes use of this possibility.

The transmitter (figure 2) consists of an oscillator (T5/T6), running at 150 kHz, which is triggered by a monostable multivibrator (T4). This monostable can be triggered either by the front-door bellpush (input 3) or by the telephone amplifier (input B). If it is not convenient to run the front-door bell and the telephone over the same transmitter, more than one transmitter can be used.

Since it is not officially permitted to derive the telephone signal from electrical pulses inside the receiver, an inductive pick-up or microphone must

be used. An amplifier boosts this signal to a useful level (figure 1). T3 is also used for rectifying the AC signal picked up from the telephone.

The receiver (figure 3) consists of a two-stage amplifier (T7/T8), a rectifier circuit with a sufficiently long time-constant to reject brief interference pulses, and a multivibrator (T9/T10). To avoid problems with the neighbour's bell extender, it is advisable to set the sensitivity of the receiver to the minimum value consistent with dependable reception. This sensitivity can be adjusted with the 1 k preset

potentiometer. The components should not be a problem: an equivalent for the BC547b is the BC107b (see 'TUP-TUN-DUG-DUS', elsewhere in this issue); similarly, the BC557b is equivalent to a BC177b. The supply transformers used in the circuit can be normal bell transformers; transformers T1 and T2 are ϕ 20 mm ferrite pot cores with an air-gap, such as the A1 250. In each case,

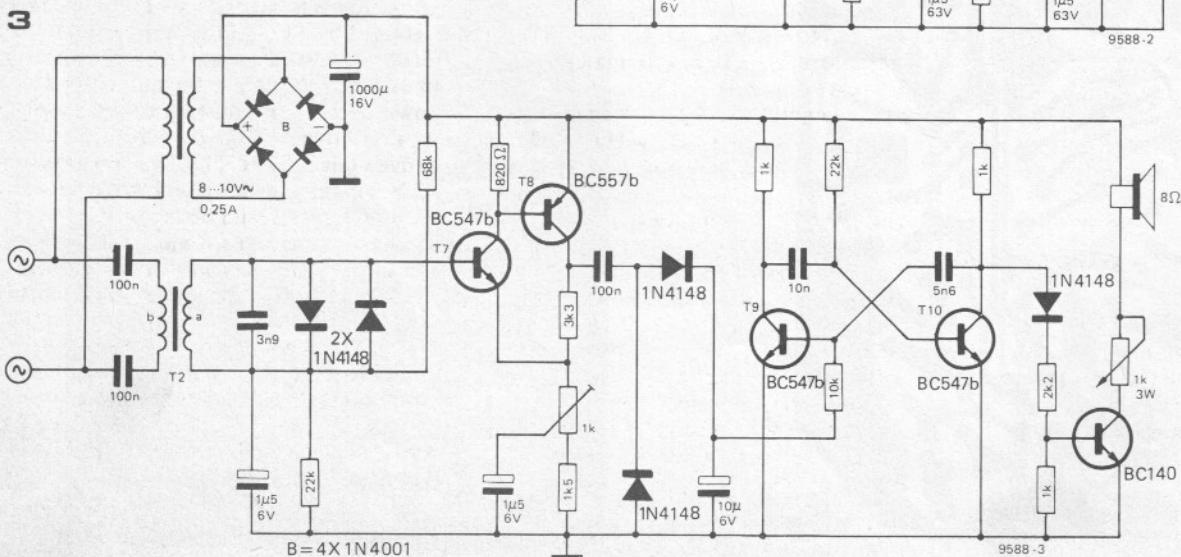
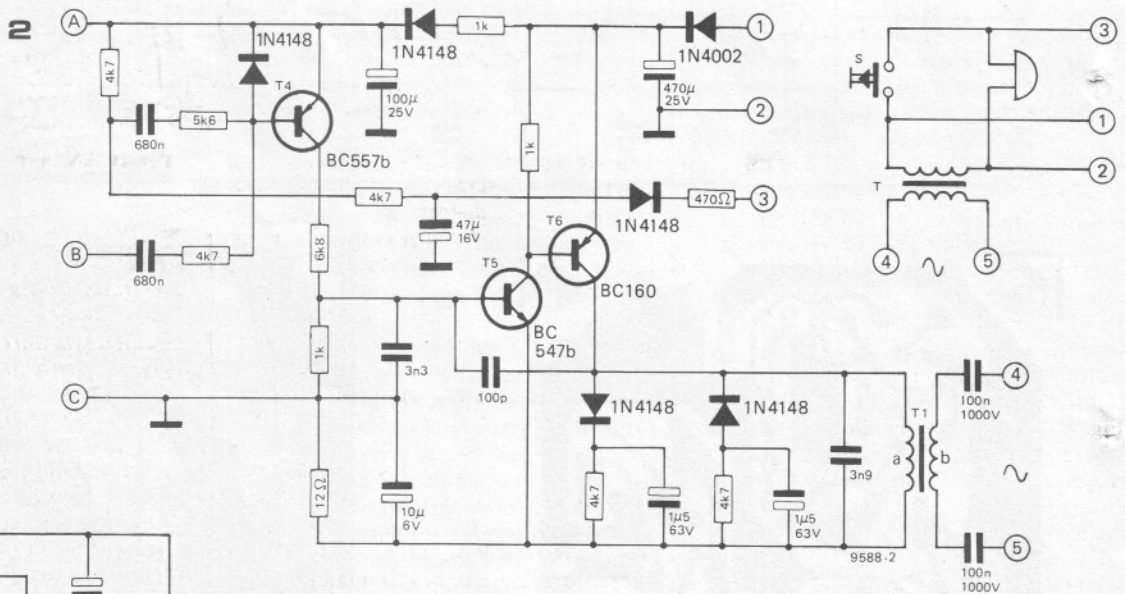
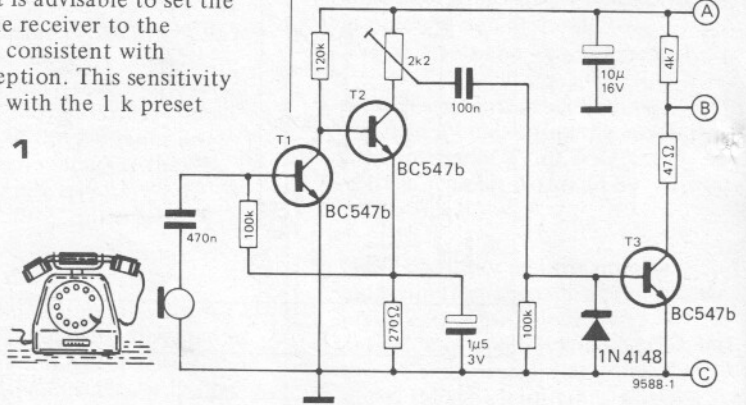

53 single transistor sawtooth generator

54 class A amplifier re-considered

55 0-30 V/1 A, stabilised

G. Ebner

winding 'a' consists of 40 turns of 0.3 mm copper wire (31 SWG) and winding 'b' is 20 turns of the same wire.

53 This simple sawtooth generator makes use of the 'reverse' characteristic of an NPN transistor: the emitter is positive with respect to the collector and the base is not connected. Under these conditions, certain types of transistor show a V_{ce}/I_c characteristic with a negative resistance kink (over a certain limited operation range), similar to the tunnel diode or unijunction transistor characteristic.

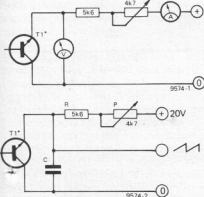

Medium power transistors such as the 2N2218 and 2N2219 show this phenomenon to a pronounced degree. It is no use trying ordinary TUN's. Finding the most useful specimen is a question of trial and error, either by measuring the V_{ce}/I_c characteristics in the circuit of figure 1, or by hooking-up the circuit of figure 2 and plugging in various transistors until one works.

Figure 2 is the simple sawtooth oscillator circuit. The R and C values and the 'negistor' breakdown potential determine the sawtooth frequency. The capacitance value (C) can be between 10 n and 1000 μ . P is used to vary the frequency over a certain range. For frequencies of over 45 kHz the output wave shape will become more like a sine-wave. The sawtooth peak-to-peak amplitude will be about 2 V.

Popular Electronics

54 In this amplifier-with-a-difference the 15...20 watt output stage operates in Class A. Due to a sliding bias arrangement, the quiescent current increases as the drive swing increases.

The class distinction between A and B modes of operation becomes apparent when considerations of high fidelity are

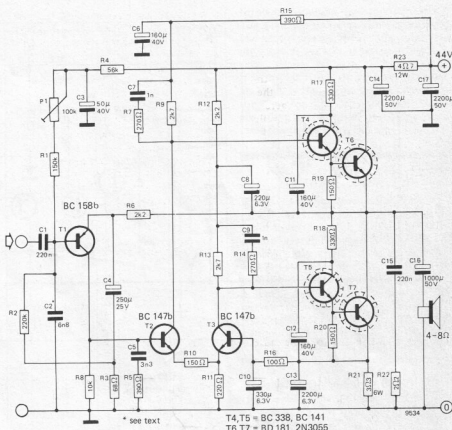

weighed against efficiency considerations. Class A stages are inherently free from cross-over distortion.

The drawback of class A systems is their low efficiency compared to class B stages.

With this design, and using a 44 V power supply the quiescent current will be approximately 960 mA. An output power of about 15 W will be delivered into an 8 Ω load, or 20 W into a 4 Ω load.

Harmonic distortion will remain below 0.1%. The input sensitivity will be about 360 mV for 15 W into 8 Ω and about 300 mV for 20 W into 4 Ω loads. The input impedance is approximately 150 k.

For preamplifiers with a 1 k source impedance, capacitor C2 will be 6n8, for 2 k source impedance it will be 3n3, and so on.

The amplifier is short circuit proof; if there is a short it will draw approximately 1.6 A.

Control P1 is used to offset the no-signal output voltage at the R18/R19 junction (approximately 21 V).

Each output transistor (T6 and T7) requires a generous heat sink, the thermal resistance should not be less than 3.3°C/W; drivers T4 and T5 require a clip-on heat sink.

Mullard Technical Communications.

55 Power supplies are always useful, and, in spite of the fact that integrated voltage regulators are now becoming quite readily available, a circuit using only standard components may be of interest.

To avoid wasting too much power, and to limit the dissipation in the series regulator, the total 0-30 V control range is subdivided into three smaller ranges. Each of the three ranges corresponds to an appropriate secondary supply voltage (selected by S1a) and an appropriate reference voltage (selected by S1b).

In order to obtain continuous control down to 0 V, a negative auxiliary supply must be added. In the circuit, this is derived (via D5 and C2) from a separate 12 V winding on the mains transformer. An alternative would be to use an auxiliary mains transformer; a cheaper solution was described in an earlier issue of Elektor ('+0/-' from one transformer winding', Elektor 5, p. 724).

The results measured on the prototype are quite good: ± 35 V mains voltage swing caused only ± 25 mV swing of the output voltage, at full load (1 A) the A.C. component of the output (hum) was less than 15 mV.

The circuit operates as follows. A reference voltage, derived from the

55 0-30V/1A, stabilised (cont.)

56 TV modulator

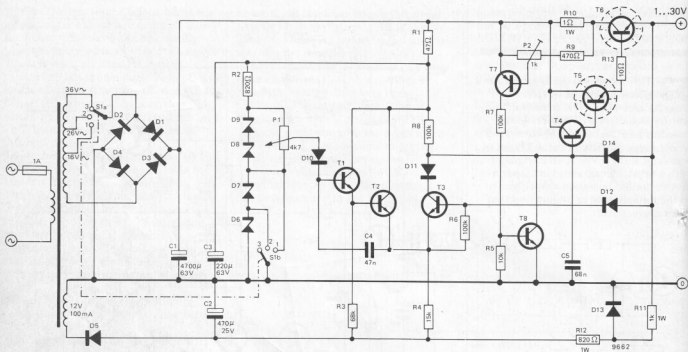

D1...D4 = 4 x 50 V/2 A...850 C2200
 D5, D13 = 1N4001
 D10, D11, D12, D14 = 1N4148
 D6, D7 = 10 V 400 mW 5%
 D8, D9 = 5V1 400 mW 5%

T1, T2, T3, T4, T8 = BC107
 T7 = BC177
 T5 = BD137
 T6 = 2N3055

zener diode(s) D6-D9 and set with P1, is applied to the base of T2 via D10 and T1. T2 and T3 operate as a differential amplifier; the output voltage is applied to the base of T3 via D12. The output of this differential amplifier is applied, via D11, to the base of the 'compound' series regulator consisting of T4, T5 and T6. Even if it looks a bit complicated, this is a standard regulator circuit; it keeps the output voltage practically constant over a wide range of output currents.

T7 and T8 with associated components are a current limiter stage. When the voltage across R10 reaches a specific value (set by P2) T7 starts to conduct. This, in turn, causes T8 to conduct; the base drive to T4 is reduced, pulling down the output voltage so that the output current remains within the preset limit.

Position 1 of S1 corresponds to an output range of 0-10 V, position 2 gives 10-20 V and position 3 gives 20-30 V. P1 gives a fine adjustment within the range set by S1. The maximum output current is set with P2. This control can either be preset to give a maximum output current of 1 A or used as an adjustable output current control. Note, however, that the current limiter is not operative when P2 is turned fully

towards the emitter of T7; either handle this control with care, or else add a series resistor between P2 and the emitter of T7 of approximately 2k Ω .

56 One of the major disadvantages of simple video modulators is that the stability of the oscillator is usually insufficient. This leads to drift and unwanted frequency modulation. A far better modulator can be built

using a cheap 27 MHz crystal. The first transistor in the circuit is the crystal-controlled oscillator. This is followed by a two-stage amplifier/pulse shaper, which converts the basic oscillator signal into short pulses with a rise time of approximately 1 nanosecond. Due to this extremely short rise time, all harmonics of the 27 MHz are present in the output signal.

The series-type mixer stage has a video bandwidth of approximately 7 MHz. It should be noted that this simple circuit inverts the modulation signal.

The prototype proved capable of giving high quality TV throughout the whole VHF and UHF band.

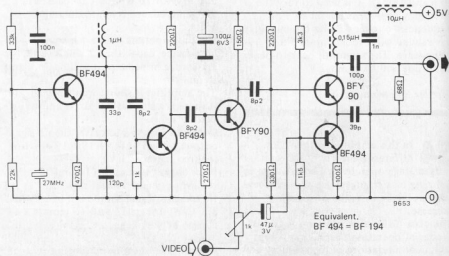

Equivalent.
 BF 494 = BF 194

57 poker 58 schmitt trigger

57 Sometimes one wonders why some people seem to want to do everything electronically. A case in point is the set of poker dice described here. Admittedly, the circuit has the advantage that it makes it almost impossible to cheat — even when playing bluff poker ('liar dice') . . .

The 'dice' in this circuit are 6-bit shift registers driving six LEDs each. Each LED represents one face of the 'die': 9, 10, jack, queen, king or ace. A poker set consists of five dice, so the circuit shown in figure 1 must be repeated five times. 'Rolling the dice' is achieved by starting the oscillator (N13/N14). Since there are five oscillators which can each be set to a different frequency, there is even less chance of a 'controlled throw' than in normal poker.

The circuit shown in figure 2 controls the number of dice to be rolled as well as the length of the roll.

A game now proceeds as follows: The first player rolls all five dice. To do this he first sets all five set-reset flip-flops which control the five oscillators, by briefly touching each of the five touch switches ('1' to '5'). He then touches the 'start' contacts, starting all five oscillators.

When he feels that the dice have rolled long enough, the player touches the 'stop' contacts. This stops the oscillators and resets all five flip-flops. The result of the throw can be read off on the LEDs.

The next player must now try to get a higher score by rolling one or more of the dice again. He selects the dice that he wants to roll by touching the corresponding contacts. Then he, too, touches the 'start' button and ends the

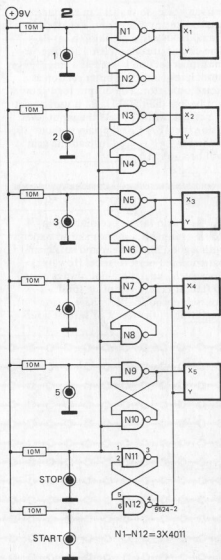

throw by touching the 'stop' contacts. The game continues in this way until one of the players either fails to beat his predecessor's score, or else gets five aces.

In some variations of the game, six dice are used. It is a simple matter to extend the game for this: one extra unit according to figure 1 and one extra set-reset flip-flop are added.

58 As long as the input voltage to this trigger circuit is less than the lower threshold level, T1 is cut off; T2 will be saturated through R2.

Consequently, the T2 collector voltage will be low, determined by the T2 saturation voltage (approximately 100 mV) and the voltage across the positive feedback diode D2. The latter voltage can vary over a limited range as a function of the power supply voltage and the R3 resistance. Both these parameters may be selected between wide limits without upsetting the operation of the circuit.

If the level of the incoming signal exceeds the upper threshold level, which is determined by the voltage across D2 and the T1 base-to-emitter threshold, T1 will conduct. When T1 reaches the saturation point, T2 will be blocked, so that the voltage on its collector will equal the power supply voltage.

R1 limits the T1 base current should the input signal be high and positive. D1 may be fitted to protect the T1 base-to-emitter diode should the input signal go too far negative.

The Schmitt trigger hysteresis is determined by the relation between R2 and R3. For R3 = R2 it is practically zero; as the value of R3 is reduced with respect to R2, the hysteresis will increase. The maximum hysteresis obtainable in this way is approximately 100 mV.

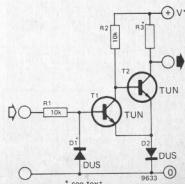
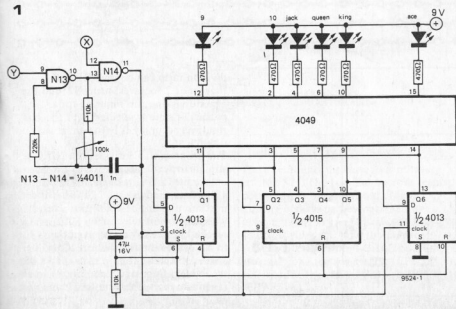

59 on-off-TAP

J. Tiernan

60 speech shifter

61 piano tuner

E.H. Leefsa

59 This circuit can be used for controlling CMOS analog switches of the types 4016 or 4066. The special thing about it is that the switch can be repeatedly turned on and off via only one touch contact. The gates N3 and N4 form an SR flipflop which is set and reset by negative pulses on point 13 and point 9, respectively. By touching the contact, a logic 1 is produced on points 1 and 6. This results in a reset pulse on point 9 if the flipflop is set ($Q = 1$), or a set pulse on point 13 if the flipflop is reset ($Q = 0$). Each time the contact is touched, the flipflop changes state. The Q- and/or \bar{Q} -output of the flipflop can be used to drive the CMOS-switch(es).

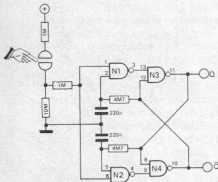

N1, N4 = CD4011 9701

Note:

The contact should be touched very briefly (shorter than about 1 s) as otherwise the circuit will function as an astable multivibrator with the output of the flipflop changing state every second.

60 Many recording enthusiasts often have some rather peculiar wishes. This device is usually one of them. It is used to alter the pitch of the

human voice, so that it can be made to sound like anything from a chattering Donald Duck to a croaking frog. The circuit uses one TBA 120. The multiplier section is used as a ring modulator, and the limiter section as a tuned oscillator. The output load should not be less than 500 Ω . P2 is used to set the effect, while P1 sets the input level. Using the TBA 120 the gain is about 20; if the SO 41 P is used instead the gain will be about 10.

61 Piano (and electronic organ) tuning is a job for skilled experts with a good musical ear and sufficient patience and perseverance. However, since such experts are not always easy to find, it is very tempting for do-it-yourself enthusiasts to have a try. Regrettably, the result of several hours

work is usually neither a well-tempered piano nor a well-tempered tuner . . .

Note	Divisor	Frequency
A	3616	879.99 Hz
G sharp	3831	830.60
F	4059	783.95
F sharp	4300	740.01
E	4556	698.43
D sharp	4827	659.22
D	5114	622.22
C sharp	5418	587.31
C	5740	554.36
B	6081	523.27
B sharp	6443	493.87
A sharp	6826	466.16

work is usually neither a well-tempered piano nor a well-tempered tuner . . . The digital tuning aid described in this article was designed to aid the amateur. It uses a stable crystal-controlled oscillator (N4-N6) followed by a programmable divider to provide all required reference frequencies. The

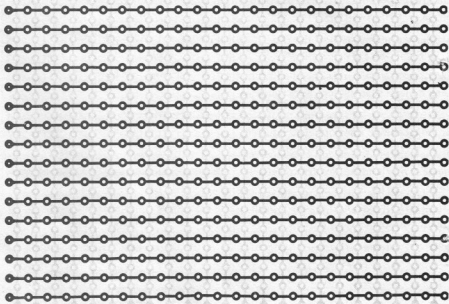

division ratio can be pre-scaled in powers of 2 (octaves) using S2, and the exact division ratio required for a particular note is selected with S1. The resulting accuracy is better than 0.006%.

The programmable divider is a fairly straightforward circuit: IC4 is the octave prescaler. Its output is fed to a three-stage counter (IC1-IC3) with a maximum count of 4096. However, when the count selected by S1 is reached, the resulting input pulse to N1 causes the first half of IC5 to be cleared. This flip-flop in turn clocks the second flip-flop in IC5 and simultaneously resets the counter chain (IC1-IC4).

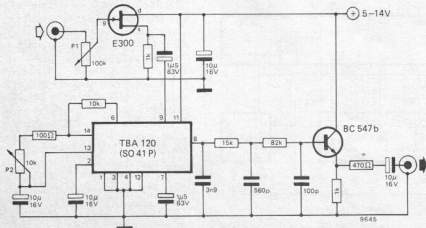

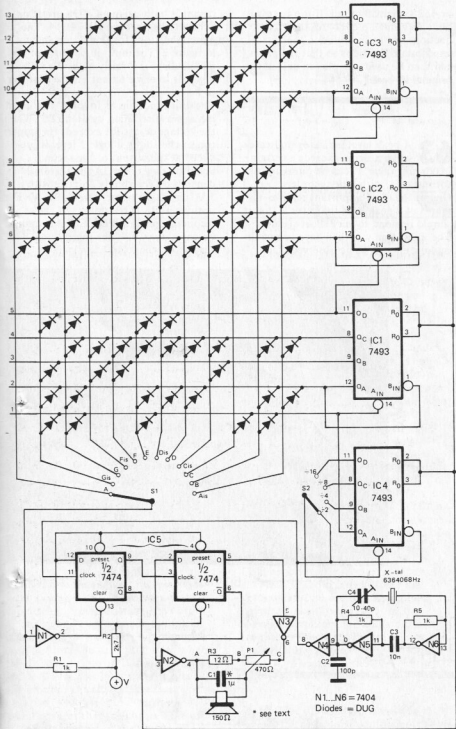

The outputs of IC5 are used to drive the loudspeaker in a simple bridge circuit. Note that the output frequency is half the frequency set by the programmable divider. The frequencies in the top octave are shown in the table. The musical instrument can now be tuned by comparing the sound from the instrument against the sound of the tuning aid. Correct pitch coincides with zero beat.

The circuit encompasses four octaves (switch S2). The top and bottom piano octaves have been omitted. These missing octaves can be obtained by using a higher crystal frequency and/or adding divider stages in the octave prescaler. Two printed circuit boards are used: one for the matrix (EPS 1497) and one for the rest of the circuit (EPS 9578).

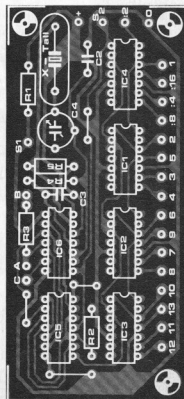
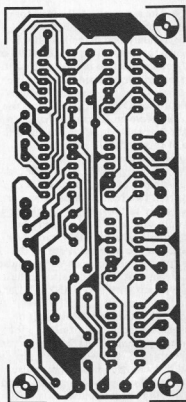

62 MMV for ACG

63 peak indicator

62 The automatic call generator or mors-o-mat (E10, February 1976) has only one drawback: IC4 is not easy to obtain. This IC, the 4098 or 4528, comprises two monostable multivibrators which are used to determine the durations of the dots and dashes. Without this IC the entire circuit is useless. Therefore an alternative has been sought that will not affect the performance of this circuit.

The problem here is that the original MMVs are retriggerable. This excludes the possibility of using simple MMVs built from two NAND-gates. However, closer study of the original circuit shows that only the dash-MMV needs to be retriggerable. The dot-MMV can never receive a new trigger pulse during the time that it is producing an output pulse. This means that the dot-MMV can be a simple circuit with two NANDs (N1 and N2 in the diagram).

The fact that the dash-MMV must be retriggerable means that it needs a lot more components. The solution chosen is to use a flipflop dividing the input signal by two. Each new trigger pulse causes this flipflop to change state, and this is used to switch between two RC circuits.

Directly following the switch-over, the diode across the resistor of the inactive RC circuit ensures that the capacitor is rapidly discharged, so that this delay circuit can be used again, if necessary, without the resulting pulse duration being affected.

The only restriction of this circuit relative to the original circuit is that the transmission speed cannot be varied because the pulse duration is determined by fixed resistors.

The terminals shown in this diagram correspond to the terminals of the 4098

or 4528 originally used. If the circuit is built on a small p.c. board, these connections can be mounted in the appropriate positions so that the panel can then be used as a plug-in unit in the original IC base.

63 A peak level indicator indicates when a signal exceeds a certain maximum value. It can be quite useful, for instance, with tape recorders. One of the most important requirements of a peak level indicator is that it should respond to very short signals. The indication will then have to remain on long enough to be observed. The

circuit is built using a CMOS inverting Schmitt trigger, type MM74C14. The pin connections for this IC are shown in figure 2. The input impedance of the peak indicator is fairly high; the value depends to some extent on the position of P1.

The unit functions as follows. The input is half-wave rectified by diode D1. When the voltage across R1 exceeds the upper trigger threshold, a logic 1 level is produced at the output of the second Schmitt trigger. The trigger threshold depends on the supply voltage; with a 5 V supply the trigger level is 3.6 V. The positive pulse at the output of the second trigger is fed back to the input via capacitor C2. If the input signal was very short, the logic 1 level will be

3

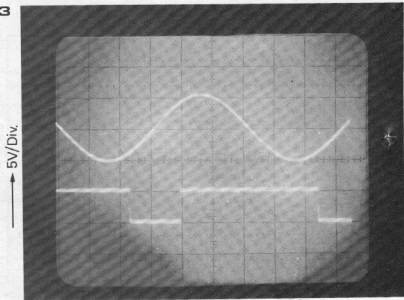

50 ms/Div.

9529-3

1

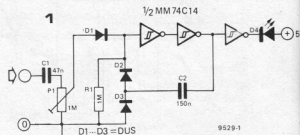

9529-1

2

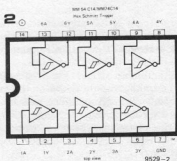

9529-2

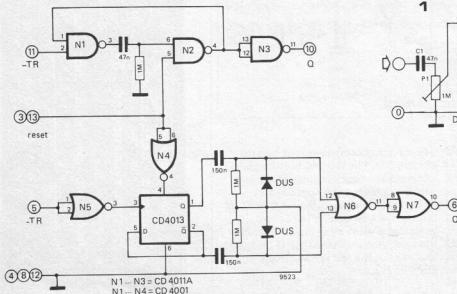

N1...N3 = CD 4011A

N1...N4 = CD 4001

9529

64 squelch

65 tremolo

66 one shot

R. Dörner

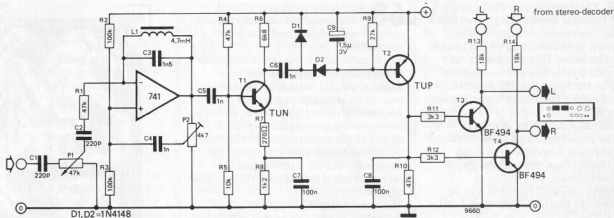

maintained during the charging time of C2. This time is determined by the values of C2 and resistor R1.

During this time the output of the third trigger is logic 0, so that LED D4 lights up as an indication that the level of the input signal is too high. The current through the LED is internally limited by the trigger; hence no current limiting resistor is needed.

Figure 3 shows a sine wave input signal on an oscilloscope screen. The lower curve is the output voltage of the second trigger. Pot P1 is adjusted to the maximum desired level that the peak indicator should begin to function at. As soon as the pre-set maximum value is transgressed, the LED lights up for at least the charge time of C2 (about 225 ms). If after this period the signal is still too large, the LED remains on until the input signal has dropped below the maximum value.

Diode D2 prevents attenuation of the positive edges of the input signal which would cause the indicator to respond less quickly. Diode D3 ensures that C2 can discharge rapidly when the output of the second trigger becomes logic 0. As a result, the indicator has immediately returned to the initial state when the discharge time of C2 has elapsed.

Diode D1 has two functions; it prevents the input of the first trigger from going negative (which would destroy the IC) and it ensures that the charge time of C2 is independent of the position of P1. The MM74C14 comprises six inverting Schmitt triggers, so that only one IC is needed to build a stereo peak indicator.

tified; this signal is used to control T3 and T4. The result is that when no station is tuned in (so that the noise level is high) T3 and T4 will be conducting and the audio signal will be shorted to ground.

The frequency selective amplifier is formed by a 741 opamp. An LC network, tuned to about 80 kHz, is connected in the negative-feedback loop. P2 controls the selectivity of the amplifier (set it so that the circuit does not oscillate), while P1 controls the squelch level. Since the 741 cannot handle large signals at 80 kHz, an amplifier stage T1 has been added. This is followed by rectification (D1, D2). The switching transistors are BF494's, since they provide a better suppression than low frequency transistors in this circuit. The signal suppression (squelch on) of a BF 494 was measured at 53 dB, as opposed to 45 dB using a BC 547 B. Connection to the receiver is relatively simple: the audio output from the demodulator before the de-emphasis circuit is taken to the input of the selective amplifier; the audio outputs from the stereo decoder are fed through the switching stages.

65 The unijunction transistor with the associated components form a pulse generator, which can be set between 1 and 15 Hz by means of control P1. The generator drives an NPN transistor with two light emitting diodes in its emitter circuit. One LED gives a visual indication of the tremolo rate, the other modulates the LDR (light dependent resistor) in the optocoupler. The circuit is switched on by opening S1. The LDR resistance varies in sympathy with the generator. Since it has been inserted in series with the signal path, it modulates the signal to create the

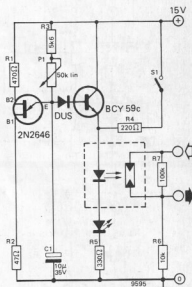

tremolo effect. This tremolo can be applied to the sound from electronically aided musical instruments, or used with recording equipment.

The LED current is about 10 mA in the conductive state of the transistor. S1 overrules the action of the tremolo circuit by causing the LED's to remain permanently activated.

64 This squelch circuit blocks the audio signal path to the amplifier when the amount of noise exceeds a certain level. The unit works in the following way: The noise around 80 kHz is filtered, amplified and rec-

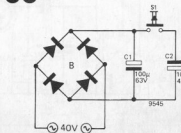
66

67 cascode current source

68 simple front-end for VHF FM

67 The performance of the normal current source using a common-emitter connected transistor can be improved by the addition of just one more transistor. This is shown in the circuit diagrams. The influence of the T1 collector voltage on the source current is greatly reduced through the action of T2.

The output characteristics of the cascode circuit approach those of the ideal constant current source much more closely than those of the single transistor circuit.

In figure 2, diode D3 sets the V_{ce} of transistor T1 just above the 'knee'.

1

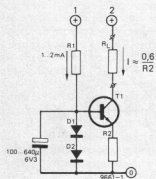

2

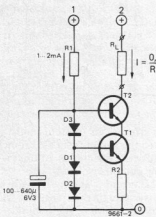

68 For mono reception of local FM transmitters with an indoor aerial, a very simple front-end is adequate.

The input stage (T1) is operated in grounded base; band-pass filters are added at in- and output to reduce the level of transmitters outside the FM band. It would be possible, of course, to use a much sharper tuned circuit at the collector of T1. This would improve the selectivity and the sensitivity, but for a simple receiver such as this it is just not worth the extra expense.

The second stage (T2) is a self-oscillating mixer. The output is matched for a 330 Ω load. At a supply voltage of 15 V the tuning range will be up to at least 104 MHz, so the same supply can be used for the front-end and varicap tuning voltage. It is advisable to use a good IC voltage regulator, such as the 723, in the interest of minimum hum and noise on the supply to the varicap. For the same reason it is advisable to use a good quality tuning potentiometer ('crackle-free'); the value can be anything between 10 k and 100 k. If the potentiometer proves to 'crackle' more than is acceptable, a 1 µF capacitor can be connected between its slider (point 'V' in the circuit) to supply common — although this will result in 'sluggish' tuning.

When used in combination with a simple IF strip, the sensitivity will be about 10 µV for 26 dB S/N. The image rejection will be about 15 dB, and the oscillator voltage fed back to the aerial input is about 1 mV.

These specifications are not at all spectacular, but they are adequate for receiving local transmitters in mono on a simple whip aerial. The receiver should never be connected to a high gain outdoor aerial, since the radiation from the local oscillator would be sufficient to cause interference on any other receivers in the vicinity. The same holds for most portables, for that matter.

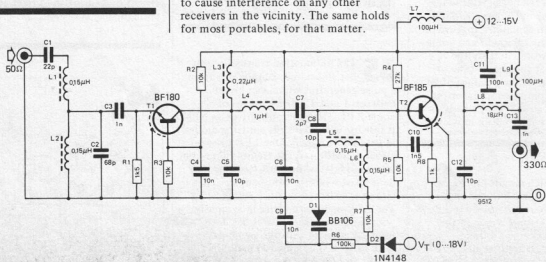
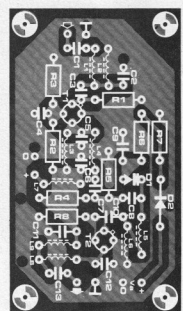
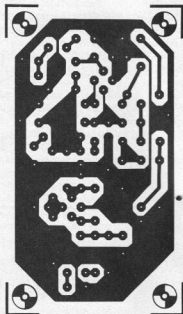

69 sample/hold synthesiser 70 single sideband adapter

69 This synthesiser is primarily intended for use in portable communications receivers which use 'up' conversion. The 100 k ten turn pot is used to set the output frequency. However, when this frequency becomes closely related to a harmonic of the 1 MHz frequency standard, the VCO locks on and gives a stable output signal. This lock occurs every 1 MHz within the tuning range of the coils. The inductor values as shown in the diagram work over a frequency range of approximately 16 to 32 MHz. By changing these coils, different frequency ranges can be covered; the maximum usable frequency will be about 70 MHz. If construction is carried out with due care and shielding is used around the different circuit blocks, spurious outputs will be more than 60 dB down. The output frequency accuracy is dependent upon the accuracy of the 1 MHz crystal in the pulse-box. The pulse-box generates the standard frequency; the output contains strong harmonics extending up to about 70 MHz. The sample/hold circuit uses a pair of E300 FETs.

The circuit efficiency can be improved by using a balanced configuration in this stage. An E420 dual FET will work well. This should also greatly reduce the influence of power supply fluctuations upon the circuit performance. The job of this circuit is to compare the harmonics from the pulse-box with the frequency of the TVCO (tuned voltage controlled oscillator) and produce a control voltage which is used to tune the TVCO. This feedback mechanism results in the desired frequency lock. The TVCO is buffered to keep the 1 MHz pulses from finding their way into the output, as this would produce undesirable side bands. If frequency lock is lost an alternating current is produced at the output of the sample/hold circuit. After amplification, this is used to light a LED.

70 It is very easy to make a good SSB adapter using the SO 42-P IC. Its output enables a symmetrical oscillator to be built with great ease. In order to minimise the influence of different source impedances, the input is terminated with a low resistance. It is recommended to limit the working frequencies to below 1 MHz. The coil in the diagram is a 455 kHz IF transformer.

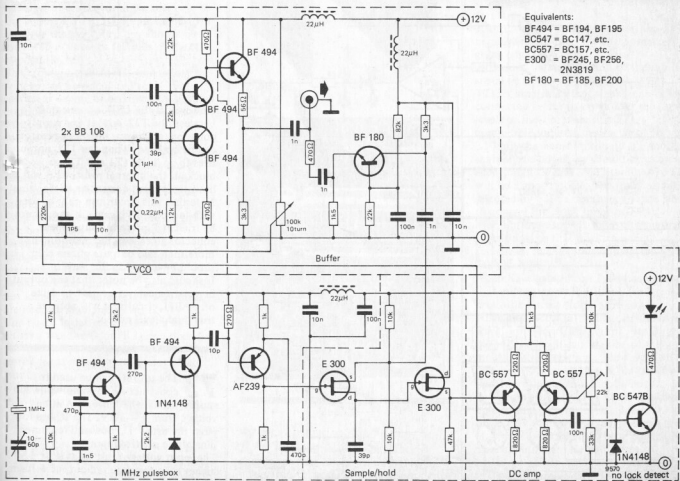
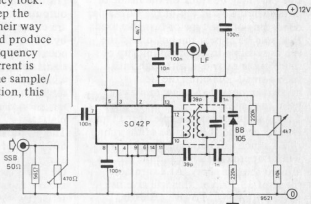

- Equivalents:
 BF494 = BF 194, BF 195
 BC547 = BC147, etc.
 BC557 = BC157, etc.
 E300 = BF245, BF256, 2N3819
 BF 180 = BF 185, BF 200

71 digital speed readout for turntables

72 driving LEDs from TTL W. v. Rooijen

73 variable regulated supply

71 The basis of the system is a magnetic sensor that picks up pulses from a magnetic tape around the periphery of the turntable. The tape is a premagnetised plasti-ferrite strip as used on wall planner charts, and sold under the name Sasco Magna Tape. This is available in 5 mm and 10 mm widths, either of which are suitable for this application. The tape is magnetised alternately N and S along its length with a pole-pitch of approximately 6.4 mm.

The tape may be stuck on the inside or outside of the outer rim of the turntable, depending on the type of turntable used. It should be as near the bottom of the rim as possible to avoid any pickup of field by the cartridge, although with such a small pole-pitch the field is negligible more than a few mm away from the tape.

Taking a numerical example, if the tape is stuck around the outside of the rim of a 12 inch (300 mm) platter, there will be approximately 148 pole pitches around the periphery. At a turntable speed of 33.3 r.p.m. this will give rise to a 82 Hz signal. To give a 3 digit readout the counter chain must count

333 pulses, so the counter gate period must be 4.06 secs. This seems slightly long, even though the speed being measured is nominally constant, but fortunately the necessary gate period can be halved by full-wave rectifying the input signal, thus doubling the frequency.

The circuit

Pulses from the pickup coil are amplified by IC1 and inverted by IC2. The positive half-cycles of the IC1 and IC2 outputs are selected by D3 and D4 and are clamped to CMOS compatible level by R5, R6 and D7. The pulses are counted by a 3-decade counter, the gate signal being provided by a 555 timer, which can be adjusted to suit the pulse rates produced by different lengths of magnetic strip on different diameter platters.

The pickup coil can be made by winding 500 turns of 0.2 mm wire (36 SWG) on a large nail.

On turntables having a built-in strobe around the rim of the platter a retro-reflective optical source/sensor arrangement may be used. In this case, on two-

speed 33/45 turntables the 33 strobe should be used as this has the most markings. The 33 r.p.m. strobe has 182 dots around the periphery of the turntable so the existing counter gating circuit can be used with no modification of component values.

72 The accompanying figure shows the output circuit of a normal TTL gate.

The usual way to drive an LED from such an output is shown dotted: the LED and a series resistor are connected between the positive supply and the TTL output. The LED is on when the output is 'low'; T3 is in saturation, so the series resistor is needed to limit the current.

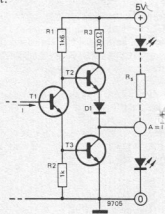

However, if the LED is connected between the TTL output and supply common, as shown, the series resistor can be omitted. When the TTL output tries to go 'high' (T1 and T3 are blocked) the internal resistor R3 will limit the output current to a safe value. Note that this circuit can only be used with 'normal' TTL gates. It should not be tried at flipflop outputs, open collector gates, etc. Furthermore, not more than two outputs of one chip should be loaded in this way. It should also be noted that the output in question cannot be used to drive other TTL circuits: it will not give a true 'high' level output.

73 The μ A78G can be used to construct a very simple power supply which will deliver 1 A at any voltage from 5 – 30 V. The IC has four pins: the usual '1', 'out' and 'common' pins plus a control input. The input voltage must be at least 5 V higher than the required output voltage; the maximum input voltage is 40 V and

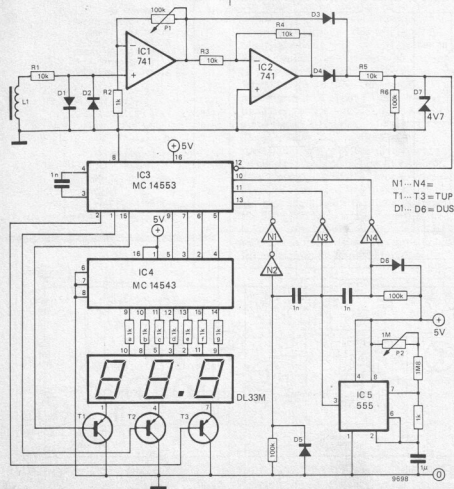

74 PIP meter

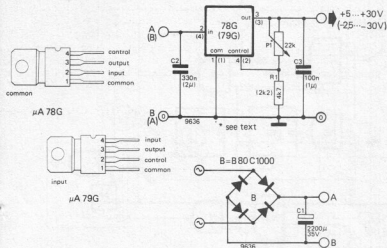

the maximum dissipation is 15 W. It is not easy to blow up this IC: it has built-in thermal and current overload protection circuits.

Using the component values shown in the diagram, the maximum output voltage will be approximately 28 V, but if a 25 k potentiometer is used for P1 the voltage can be set to over 30 V. An alternative solution is to reduce the value of R1 slightly by adding a 68 k resistor in parallel.

Capacitors C2 and C3 are included to improve the stability; they should be mounted as close to the pins of the IC as possible.

The required transformer secondary voltage can be calculated to a sufficient degree of accuracy by simply multiplying the desired raw supply voltage (i.e. the maximum output voltage plus 5 volts) by 0.7.

For a negative stabilised supply a different IC can be used in the same circuit: the μ A79G. In this case this component values shown in brackets should be used.

Either circuit can be mounted on the p.c. board shown; for the negative supply version the polarity of the bridge rectifier and of C1 should be reversed. Furthermore it should be noted that the pinning of the two ICs is not identical, so some extra wire links are needed when mounting the 79G. The board is designed to accommodate either a fixed resistor (R2) or a preset potentiometer for P1; it is also possible to run leads to a potentiometer on the front panel.

If the fixed resistor option is chosen, the value can be calculated as follows:

$$R_2 = \frac{4700}{5} \times (V_{\text{out}} - 5) \text{ for the } 78\text{G}; \text{ or}$$

$$R_2 = \frac{2200}{2.2} \times (V_{\text{out}} - 2.2) \text{ for the } 79\text{G}.$$

Fairchild application note.

very few parts, and is easy to build is shown in figure 1. The unit can be used with no internal connections to the counter, but if it is connected into the internal counter circuitry it will be much easier to work with.

The basic idea of period measurement is the inverse of normal frequency measurements: For frequency measurements a time base is used to open and close a gate, for a specific length of time, allowing the input signal to flow into the counters during this specific period.

For period measurements, the input signal controls the gate, allowing a standard frequency from the time base to flow into the counters during the period to be measured. This standard frequency time base, not shown in the circuit, is connected to input 3.

1 kHz is used, however any standard frequency such as 10 kHz or 100 kHz will do equally well. The higher the standard frequency, the higher the readout resolution will be.

The PIP meter makes 3 different types of period measurements:

1. Pulse: the period between the positive-going edge and the negative-going edge (+ to - of the input wave form).
2. Interval: the period between the negative-going edge and the positive-going edge (- to +).
3. Period: the total period of the input signal (+ to +).

TTL-compatible input signals can be connected direct to input 2. If the signal levels or rise-times are not TTL

compatible, input 1 can be used: Rs and Z1 limit the signal levels and N1 and N2 sharpen the edges. Rs should be chosen according to signal level; usually 470 Ω will be a good choice. The input signal, selected by S1, passes through gate N5 to control the clock input of FF1. The flipflop responds to negative going transitions, so that positive-going transitions at the input of inverter N5 will clock FF1.

When S2 is in position 1, and assuming that initially both flipflops have been reset, the circuit works as follows:

When the first positive edge of the input waveform occurs, FF1 'flips'. Its Q output goes high causing one of the inputs to N6 to be high. However, N6 remains blocked as long as the input signal remains high, since the output of inverter N3 is then low. As soon as the input signal goes low, (this does not cause FF1 to change state) the output of N3 becomes high. With two of its three inputs high, N6 can pass the 1 kHz standard frequency connected to its third input. Gate N6 remains open until the next positive going

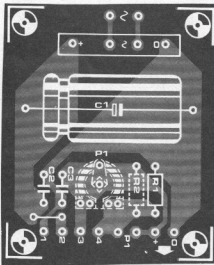
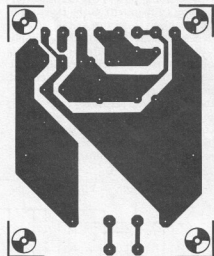

74 It is relatively easy to extend the capabilities of a frequency counter so that it is possible to make pulse, interval and period measurements. An extension circuit which contains

74 PIP meter (cont.)

75 electronic voting system

76 handy dark room timer

H.F. Blom

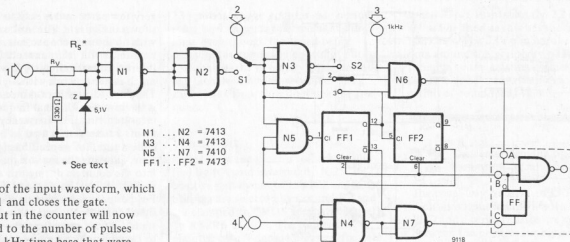

transition of the input waveform, which 'flops' FF1 and closes the gate.

The readout in the counter will now correspond to the number of pulses from the 1 kHz time base that were passed during one interval of the input waveform. If the counter reads, say, 3000 this would mean the gate was open for 3 seconds. So when a standard frequency of 1 kHz is used, the readout has a resolution of 1 msec.

When FF1 'flops' at the end of the first input period, it 'flips' FF2. The Q output of FF2 goes 'low', blocking N5 so that no further clock pulses can reach FF1. The system now remains disabled until both flipflops are reset. In switch position 2, the only difference to the circuit is the deletion of inverter N3. This means that when the positive-going signal flips FF1, all inputs to N6 are high and the 1 kHz is passed to the counter. At the end of the 'high' part of the input waveform ('pulse') N6 is blocked. The readout now corresponds to pulse length.

When S1 is in position 3, only the Q-output of FF1 is used to control the gate, so that it remains open during the whole period from the first to the second positive-going edge of the input waveform.

The output of gate N6 can be connected direct to the counter input. The counter's gate must be modified so that it will stay open during the entire period on the input waveform. To do this, the output of N7 is fed to the control input of the original flipflop in the counter gate circuit. The flipflop output can be used to clear FF1 and FF2 after one count; a pulse input to N4 will now initiate a new measurement.

75 This circuit probably meets the requirement of 'democratic' conferences, in which each participant should be able to give his vote (preferably without cross talk).

A handful of components is sufficient to enable analog-electronic voting. Each voter gets a push button with which the

corresponding TUP/TUN thyristor can be reset (if required). If the thyristor is set, a current flows through it, which depends on the values of R, R_x, supply voltage V and the saturation voltage V_d of the thyristor, which is usually about 600 to 700 mV. When a certain critical number of push buttons are depressed, the voltage drop across R_x exceeds the threshold voltage V_{dr}, causing the 741 comparator to switch and the LED to light up. The resistance is selected according to the formula:

$$R_x = \frac{V_{dr} \cdot R}{m(V - V_{dr} - V_d)}$$

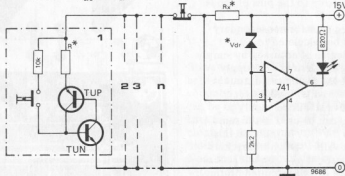

where m is the number of votes required in favour of a given proposal. This number depends on the number of voters and the type of majority required ('half + 1' or two-thirds majority).

The voting procedure is as follows: if a voter is in favour of the proposal he depresses his button; if he is against the proposal he'd better do nothing! If after the voting (and with the correct value for R_x) the LED lights up the proposal has been accepted.

A LED can be included in series with each resistor R, provided the value of the latter is suitably adapted. This provides a visual indication of the individual voting.

To make the apparatus more flexible, it is recommended to replace R_x by a

number of switchable potentiometers, or to use a potentiometer with a calibrated scale, which should be marked with different numbers of required votes (m).

For high values of m, a certain inaccuracy arises due to the offset voltage of the 741. This can be remedied by means of the appropriate compensation circuits. However, it might be considered that even democracy is not quite 100% perfect.

76 When taking a photograph, the amount of light incident on the negative is influenced by both the diaphragm and the shutter time. Both of these controls operate in such a way that one full step of either halves (or doubles) the amount of light. This logarithmic system was chosen because it enables easy work without (too much) thinking and knob turning. A linear scale is rather unpractical; if, say, the sequence 5-10-15... up to and including 90-95-100 was used, the first step from 5 to 10 doubles the amount of light, whereas the final step (95-100) is no more than 5% and would make no visible difference in the picture.

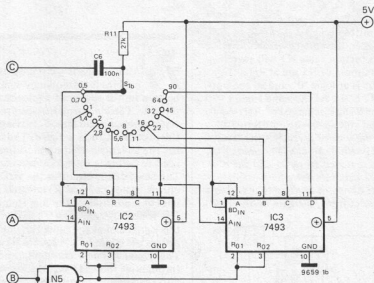
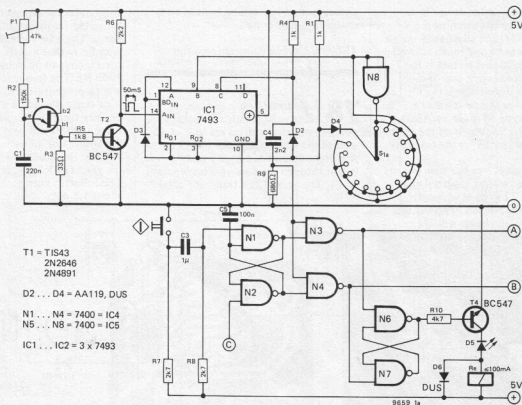

Furthermore, the total control range from 5 to 100 is only 1:20, whereas 19 logarithmic steps provide a control range of 1:500,000. Therefore it is obvious that a good design for a dark room timer will also use a logarithmic scale. To enable a somewhat finer exposure control, it should preferably also be possible to use half-stop adjustments. This is achieved by using a factor $7/5$ instead of exactly $\sqrt{2}$ in the circuit.

This timer does away with all calculation, one diaphragm stop on the

enlarger lens now simply corresponds to two positions on the timer.

Operation is as follows: The counting pulses are generated by means of a UJT (T1). T2 acts as a buffer stage between this oscillator and the first divider (IC1). This divides by 5 or 7 to provide the factor of $1/\sqrt{2} = 0.7$. This is achieved by sensing the 5 or 7 outputs via an AND-gate (D2...D4), and feeding the signal to the reset input of the divider.

The network comprised of C4 and R9 form a wave shaping circuit which

changes the square-wave output to a short pulse.

When the 'start' button is depressed, flipflop (N1-N2) changes state and the clock pulses are passed on via N3. The first pulse causes flipflop (N6-N7) to change state. This energizes the relay via T4, and the enlarger lamp is turned on. The clock pulses which are being passed by gate N3 are counted by the dividers IC2 and IC3. The rate at which the successive outputs of the dividers go 'high' has the desired logarithmic progression: each output goes 'high' after twice the time needed for the preceding output to go 'high'.

Therefore no decoding is required; it is sufficient to connect the outputs direct to switch S1b. As soon as the selected output changes from 'high' back to 'low' flipflop N1-N2 is reset.

This, in turn, resets flipflop N6-N7 (turning off the enlarger lamp), resets the counters IC2 and IC3 and blocks the count gate N3.

The time is calibrated by adjusting P1. The circuit draws about 100 mA at 5 V, so that a simple IC stabilizer can be used. It is recommended to decouple the supply near the ICs by means of a capacitor of 10 to 100 n.

77 touch activated dimmer

78 transistor tester

A. Schiplage

79 audioscope

J. Schmidt

77 A feature of this device is the possibility of switching a dimmer (IC2, U112B) alternately on and off by means of one touch activated contact. An additional feature is the possibility of connecting one or more remote control units (IC1, U113) in its basic design the device uses a single U112B type IC made by AEG/Telefunken. The brightness of the light is controlled (or preset, as the case may be) by P1.

Since the voltage across the triac powers the IC, the triac will be triggered at a phase angle of 22 degrees or more, leaving sufficient voltage to power the IC. Admittedly, the lights will not receive full power, but the difference will be barely noticeable. The R6 + C8 combination limits the current to the IC. Note that C8 and C10 must safely stand the full mains voltage; this means that they should be rated for 450 V DC wkg. The tap contact is protected by two 4M7 resistors.

These resistors are an absolute necessity to prevent electrocution!

A short switching delay has been introduced in the touch switch input circuit to reduce the influence of interference. This delay is set by C5, and by C7 and C2 for the remote control circuits. The values which are given can be altered if necessary.

Any number of remote control ICs can be added between pin 14 and pin 3 of the U112B.

The device will not work satisfactorily unless the live and neutral mains connections are made as indicated in the diagram.

All resistors can be 1/4 watt. Unless otherwise indicated, capacitors are 100 volt types. Inductor L is an interference suppressor coil for triac control. Practically any type of triac will be suitable.

With some skill and patience, the basic

circuit around IC2 can be built in to a traditional light switch.

AEG/Telefunken Application notes

78 This circuit when used in conjunction with a frequency counter will give a direct readout of the gain of the transistor under test (T1). A current determined by R2 and P1 is sent through the base-emitter junction of T1. The gain of this transistor deter-

mines the charge time of C1 and hence the frequency of the output signal. The base current can be adjusted with P1 so that a current gain of 100 corresponds to an output frequency of 1000 Hz. The frequency of the output will be proportional to the gain over a wide range, therefore β can be read directly from the counter.

If required, the output frequency for $\beta = 100$ can be adjusted to 100 Hz or 10 kHz; this is achieved by changing the values of R2, P1, and C1.

The collector current of T1 is usually about 1.8 mA.

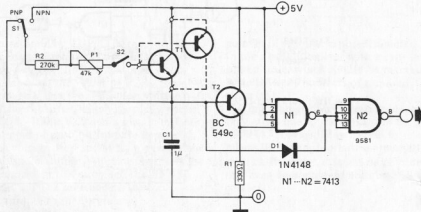

mines the charge current of C1.

The Schmitt trigger N1 is driven by T2, so that when the voltage across C1 reaches a certain value N1 will switch. When all inputs of N1 are at logic '1', its output is at logic '0', and so the output of N2 is '1'. At the same time, capacitor C1 is discharged via D1. As a result, the voltage at the emitter of T2 drops rapidly until it reaches the level where N1 switches back. The short circuit is removed from C1 and the output of N2 becomes low.

From the above, it appears that with a fixed base current, the gain of T1

79 Audioscope is a circuit which enables low frequency signals to be seen on the screen of a television receiver. The electronic circuit produces vertical bars on the screen, moving in the rhythm of the LF signal. The circuit has the advantage that no modifications need to be made to the TV set.

The heart of the circuit is the astable multivibrator (T2 and T3), which oscillates at a multiple of the line frequency. The following transistor T4 amplifies this signal and at the same time improves the edges of the square wave. This signal will now contain harmonics throughout the VHF band, and even into the UHF band, so it can be fed direct to the aerial input of a television receiver. After synchronisation with the line frequency, the screen shows one or more black bars, according to adjustment. Synchronisation and the required number of bars are set with P2. This potentiometer is adjusted until the picture is stationary with P1 set at zero (no LF signal).

After P2 has been adjusted, P1 can be turned up slowly. The bars will move horizontally in the rhythm of the input signal.

Further interesting effects can be achieved, such as by mixing a normal

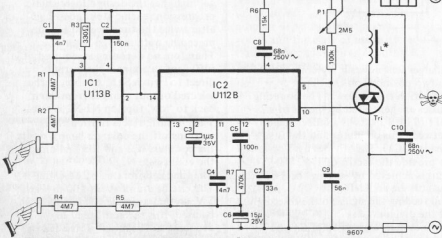

* see text

80 dissipation dumper

Parts list

resistors:

- R1, R4, R5, R6 = 10 k
- R2 = 22 k
- R3 = 100 k
- R7, R8 = 39 k
- R9 = 4k7
- R10 = 15 k
- R11 = 8k2
- P1 = 100 k log
- P2 = 47 k

capacitors:

- C1 = 33 n
- C2 = 22 n
- C3, C4 = 330 p
- C5 = 1 n
- C6, C7 = 1 n/400 V

semiconductors:

- T1 = TUN
- T2, T3, T4 = BF494, BF194

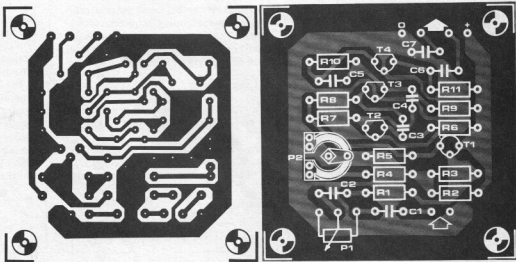
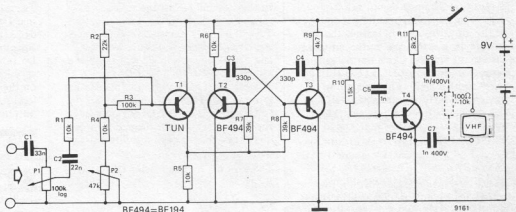

TV picture with the accompanying sound which is also made visible. The output of the circuit is simply connected to the (VHF) aerial input of the television receiver. The described effect shows up best on channels 2, 3 and 4. The current source of this circuit is provided by a 9 V battery.

two power transistors, a power resistor (R2) and a few extra components. The complete circuit is equivalent to a single NPN power transistor. The 'collector', 'base' and 'emitter' are marked with arrows.

The interesting point about this circuit is that the maximum dissipation in the two power transistors is only about one

quarter of the maximum total dissipation; the rest (three quarters) is dissipated in the resistor R2.

The circuit operates as follows. T1, D1, D2, R1 and R3 form a current source, which biases the zener diode D5. At low output currents, the voltage at the collector of T3 will be higher than the voltage at the collector of T1. This

80 Nearly all stabilised power supplies use a series regulator transistor. The dissipation in this transistor increases with increasing load current and with increasing voltage across it. This means that it is often necessary to use several transistors in parallel for the series regulator, and to incorporate a large heatsink - certainly if the power supply is to have a variable output voltage at high output currents (lab power supply). It is cheaper to dissipate as much as possible of the excess heat in a resistor, provided some way can be found to do this without interfering with the voltage stabilisation. The circuit shows a replacement for the original series transistor, consisting of

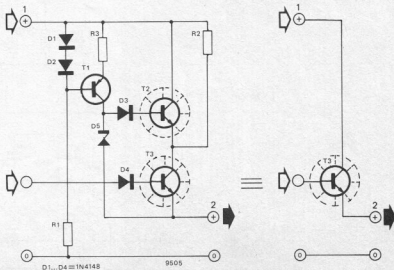

80 dissipation dumper (cont.)

81 sound effects generator

J. Klasek

means that T2 must be cut off. The voltage at the collector of T3 is equal to the input voltage '+1' minus the voltage drop across R2. In this situation, the circuit behaves like a normal single transistor series regulator (T3) with a series resistor (R2). The maximum dissipation in T3 occurs when half the voltage difference between '+1' and '+2' is dropped across it; the load current is then:

$$I_L = \frac{'+1' - '+2'}{2R2}$$

As the current increases further, the voltage drop across the resistor increases, and the drop across T3 decreases. At a certain output current (twice the value found above) the voltage drop across T3 would be zero, i.e. the transistor would be in saturation — and that would be the limit of the stabilisation range. However, the zener voltage of D5 is chosen in such a way that T2 will start to conduct just before T3 goes into saturation. At higher load currents T2 forms a variable shunt across R2, maintaining a voltage drop across T3 that is just sufficient to keep this transistor out of saturation so that it will still work as a series regulator.

In this 'second leg' of the series regulator operation, the dissipation in T2 will increase progressively. However, the dissipation in T3 is now very low, and the dissipation in T2 will reach the same maximum found earlier for T3. For this reason, both transistors can be mounted on a common heatsink (provided insulating washers are used); the heatsink must be designed for one quarter of the maximum total dissipation.

The formula for calculating the value of R2 is:

$$R2 = \frac{'+1'}{I_{max}}$$

where '+1' is the DC input voltage and I_{max} is the maximum output current, limited by a fuse or a current limiter circuit in the power supply. The maximum dissipation in R2 equals:

$$P_{R2,max} = \frac{'+1'^2}{R2}$$

This type of power resistor is used in the electrical system of some makes of car.

The value of R1 is chosen so that a few milliamps pass through D1 and D2. R3 determines the collector current of

T1; this current must be sufficient to bias D5, even when T2 requires base drive in the second leg of the regulator. Bear in mind that this current through D5 flows into the output, so that at very low loads it may have an effect on the regulation. In this case, an extra load resistor may be needed across the output.

81 This circuit generates a wide variety of noise effects to be used as a background to, or mixed with, other sound effects; it can simulate, for instance, a helicopter's swish as well as grasshopper's chirp. The circuit operates as follows. The signal from an astable multivibrator (T1, T2, C1, P4, R4) is fed through the lowpass network R6, C4, to the modulating input of a tone generator (T3, T4). The basic frequency control of this generator is P2. Emitter follower T5 buffers the output signal of T3. As a result, a frequency modulated oscillation is available at control P3. Another astable driven tone generator

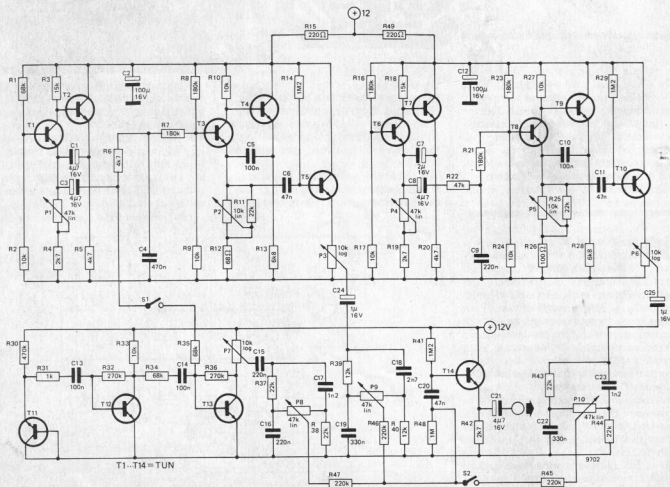

T1...T4 = TUN

82 7 watt IC audio amplifier

(T6 . . . T10) functions in the same way. Transistor T11 functions as a noise source. The signal across R30 is amplified by T12, T13 and can be superimposed, via R35 and S1, upon the signal generated by the first astable.

The signals from these three sources are passed, via controls P3, P6 and P7, to three tone filters. These filters include the tone controls P8, P9 and P10.

Finally, the output signals from the tone filters are mixed (R45 . . . R48) to produce the desired noise effect at the output of T14.

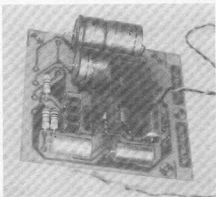

Without any additional cooling, the IC can deliver 1 Watt into a 4 Ω load with a 6 V supply. With a sufficiently large cooling fin and a 16 V supply it can deliver up to 7 W into 4 Ω , the input sensitivity in this case is 240 mV. If 8 Ω loudspeakers are used, the maximum output power is about half.

The input impedance is practically determined by P1 (1 M), so it is possible to connect a crystal cartridge direct to the input. If this high input impedance is not required, the value of P1 can be reduced.

There are two versions of the TBA810: the 'S' and the 'AS', with differently shaped cooling fins. The additional fin shown in the drawing is suitable for the 'S' version, but it will need some slight modifications to fit the 'AS' type.

The frequency response is ± 3 dB from 40 Hz to 18 kHz. The voltages shown in the circuit were measured when the unit was powered with a 16 V power supply. Note that the pin numbers in the circuit do not take account of the cooling fin; the IC has a total of 12 pins.

82 The TBA 810 has been in production for several years, and by now the price has dropped to a very reasonable level. It has built in thermal and short-circuit protection circuits, so it should have a reasonable life expectancy.

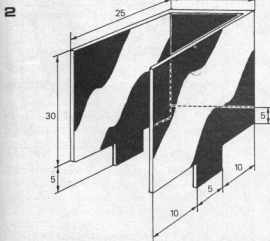
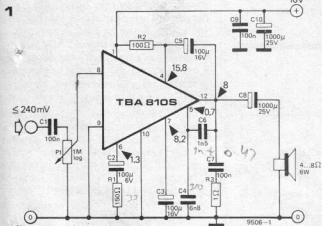

all dimensions in mm.

9506-2

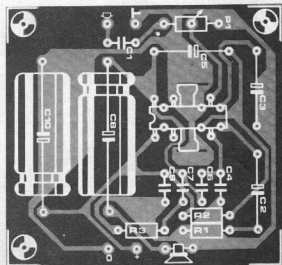
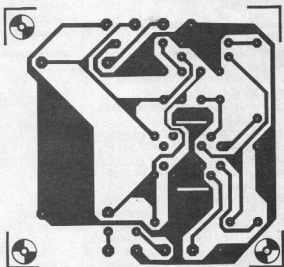

83 DSSC generator

84 battery charger

85 read-out brightness regulator

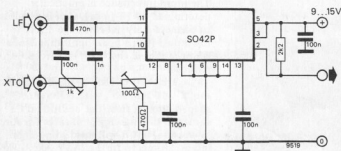

83 It is possible to maintain a carrier suppression better than 40 dB up to 10 MHz using this circuit. The load impedance can differ from the indicated value provided that the DC resistance does not exceed 2k Ω . Optimum operation will be obtained if the input circuit is driven by a signal of approximately 100 mV peak-to-peak. If it is required to 'clip' the output signal the audio signal (input) level must be increased. Carrier suppression will be reduced if the crystal oscillator signal level is too high.

84 It's summer now, but based on past experience it is to be expected that winter is just around the corner. This circuit will (hopefully) keep motorists happy on cold mornings. It automatically charges the car's accumulator overnight so in the bleak morning light the engine should wake up readily. When designing an overnight charging unit, care must be taken to avoid the possibility of overcharging the battery. To avoid this, the output voltage should be limited to a safe value. For 12 volt batteries the maximum safe voltage is about 14.1 V and for 6 V batteries about 7 V. These voltage levels are adjusted by P2 and P3. Overcharging is now prevented

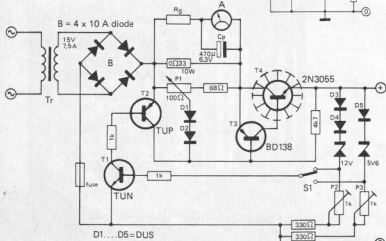

in the following way. During the charging period the battery voltage goes up; when the battery reaches a 80 or 90% charge the voltage will have reached the maximum safe voltage as set by P2 or P3. The current will then be switched off via T1 and T2. P1 sets the charging current between 2 and 6 Amps. The output current can be monitored by adding a simple ammeter. Almost any meter can be used, Rs being selected to calibrate the meter. Cp prevents the meter needle from vibrating at 100 Hz: the only other smoothing device in the charger is the car battery!

85 Sometimes it seems impossible to set the correct read-out brightness for LED displays. If the brightness is set for good daytime contrast, at night the read-out becomes blinding. The purpose of this device is to automatically adjust the brightness of seven-segment LED displays in such a way that the visible contrast compared with ambient light is maintained over a wide range of ambient light levels. This is done by using a transistor which chops the positive supply voltage to the readout device. The chopping frequency is about 1 kHz; the amount of ambient light determines the duty cycle (on/off). Due to the persistence of the human eye, the readout will not be seen to flicker. To give an example, if the on/off ratio is assumed to be 1:1, the average readout current will be about half the non-chopped value. As a result, the LED brightness will also be about half.

The device uses two LDRs (light dependent resistors), one to sense the surrounding light and the other to sense the display intensity. Since it is not convenient to mount an LDR in front of the display itself, a 'slave' LED (D1) is connected in parallel with the display and is used to sense the readout brightness. A sawtooth signal is generated by IC1a and IC1b at a frequency of about 1 kHz,

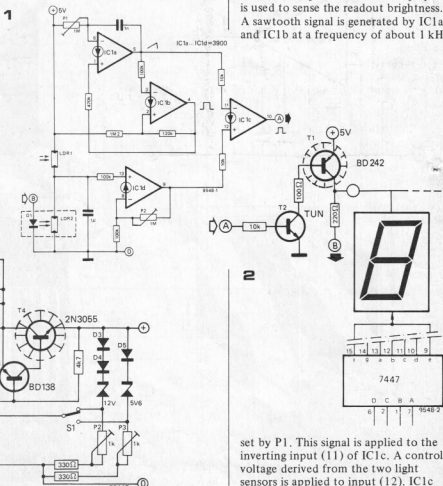

set by P1. This signal is applied to the inverting input (11) of IC1c. A control voltage derived from the two light sensors is applied to input (12). IC1c

86 hafler circuit for quasi-quadrophony

87 bird-bell

H. Geuer

now operates as an analogue-to-pulsewidth converter. The design parameters are such that under average lighting conditions the output on/off ratio is about 1:1. This duty-cycle varies as a function of the control voltage: an increase in control voltage causes the on/off average to increase, with the result that the display brightness (and the brightness of the 'slave' LED) increases.

The control voltage is derived from measurement of the ambient light and the brightness of D1 in the following way. Assume that the system is initially in equilibrium, i.e. the display contrast is set correctly. If the ambient light increases the resistance of LDR 1 will drop, so that the input voltage to the error amplifier (IC1d) increases. This in turn increases the control voltage so that the display will brighten, as described above.

The resistance of LDR 2 will also drop (as D1 becomes brighter) counteracting the drop in resistance value of LDR 1 to a large extent. The resulting actual voltage change at the LDR 1/LDR 2 junction will be just sufficient, after amplification by IC1d, to re-adjust the duty-cycle at the output so that equilibrium between the values of LDR 1 and LDR 2 is maintained. In effect, the circuit is a negative-feedback controlled brightness-follower!

The desired degree of contrast can be set with P2; if the range is not sufficient, some experimenting with masks between D1 and LDR 2 may be required.

Power to the display can be supplied via series transistor T1, which will safely pass up to 1 A when mounted on a small heat sink. While on the subject of this final stage, it is worth noting that some types of BCD to seven-segment decoder ICs are provided with a strobe input terminal. This can be used for 'dousing' the light emitted by the display for the duration of the 'spaces', in which case the series transistor is no longer needed.

86 Although there are, on the market, many expensive 'quadrophonic synthesiser' boxes that make use of the Hafler effect, there have, as yet, been few if any designs for the home constructor. This is a pity, as Hafler-effect boxes can provide an economic introduction to experiments in quadrophony.

The circuit is extremely simple. Two two-pole six-way switches and two banks of resistors provide 6 steps of attenuation to control the volume of

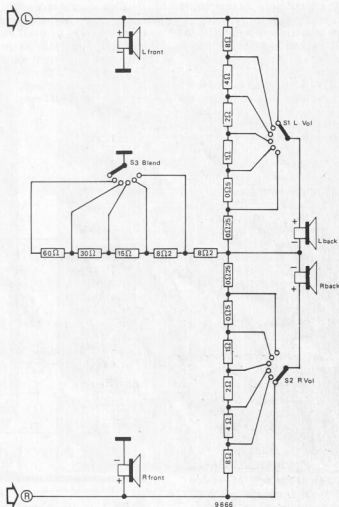

the rear speakers.

A third switch introduces six steps of resistance between the midpoint of the loudspeakers and ground, thus introducing a degree of front-rear blend. Stepped attenuators are used in preference to continuously variable resistors as high wattage resistors and switches are more readily obtainable than high-wattage low resistance pots.

circuit the doorbell transformer is equivalent to bird feed. In other words, the existing doorbell transformer can be used to power the bird.

The song frequency is controlled by the loudspeaker impedance and C2. The length of time the bird sings is controlled by C5. If C5 is made too large, the bird will sing too long; on the other hand, if C5 is made too small, the bird will HUM at 50 Hz. Which is most undesirable.

Note that it is also possible to have the bird sing with a Japanese accent, by using old parts from a broken transistor radio.

87 Tired of the same old doorbell? Here's a new twist: an electronic doorbell that sings like a bird. In the

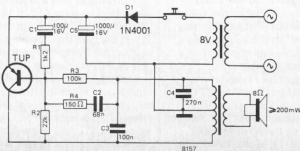

88 linear scale ohmmeter

89 symmetrical power amp.

88 The ohms ranges of most multimeters are inadequate for measuring high and low resistance values. Resistance ranges below 100Ω or above 1 M often do not exist on cheap meters, and anyway the scale is non-linear. A linear scale resistance meter that will measure between $100 \text{ m}\Omega$ and 10 M full-scale can be constructed using two op-amps, and can be used in conjunction with a multimeter on any voltage range between 1 and 8 volts, depending on the scales available on the meter. The circuit operates by passing a

constant current through the resistor under test, so the voltage developed across it is proportional to the resistance. This voltage is amplified by an op-amp and is measured by the multimeter. The voltage reading on the meter corresponds directly to the resistance value, i.e. on the kilohms range 1 volt corresponds to 1 k, on the ohms range 1 volt corresponds to 1Ω etc.

The output resistance of the op-amp IC1 has an effect, so the aforementioned method cannot be used. Instead the current is supplied from the supply rail via a constant current source. FET input op-amps are employed for their low input currents. This is necessary as on the $1 \text{ M}\Omega$ range the current is only 100 nA .

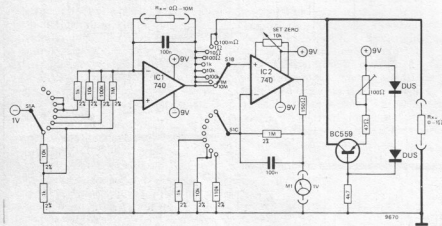

constant current through the resistor under test, so the voltage developed across it is proportional to the resistance. This voltage is amplified by an op-amp and is measured by the multimeter. The voltage reading on the meter corresponds directly to the resistance value, i.e. on the kilohms range 1 volt corresponds to 1 k, on the ohms range 1 volt corresponds to 1Ω etc.

The constant current through the resistor is produced by two different methods. On the higher ranges a constant voltage is applied to a known resistor connected to the inverting input of an op-amp. The unknown resistor is connected between output and inverting input, so the same current flows through it. The inverting input is a virtual earth point, so the voltage across the resistor is equal to the voltage at the op-amp output. Put another way, the op-amp amplifies the known input voltage with a gain proportional to the value of the unknown resistor.

On the lowest resistance range about $10 \text{ M}\Omega$ is required to flow through the resistor to give even 1 mV across it, which is the minimum that can easily be measured (even so the op-amp offset must be nulled). At this sort of current

89 This class B amplifier has a few characteristics that makes it stand out from the crowd. For one thing, not only is the final stage symmetrical and complementary, but all of the other stages are as well. The differential input stage requires an extra outlay of about 40 p , when compared with an asymmetrical preamplifier stage. The balanced design abolishes the need of expensive (and unreliable) coupling and decoupling capacitors. The loud-speaker connects straight to the final stage. Switching phenomena are inaudible. The required frequency compensation is accomplished in such a way that transient intermodulation distortion is eliminated. This was more fully described on page 452 of the April 1976 issue of Elektor (nr. 12).

To make sure that the amplifier is stable, the open loop gain must roll off at 6 dB/oct above the break frequency f_0 . In conventional circuits this would mean the driving signal would have to increase at frequencies above f_0 , also at 6 dB/oct . Under those conditions the driving signal at higher frequencies could rise to such a level

that clipping would occur. This design features a network composed of the output impedance of the preceding amplifier in series with $R7$ plus $C2$ and $R18/R19$. The signal across $C2$ is the effective signal driving the amplifier; its level decreases as its frequency rises above f_0 .

The amplifier is of universal design, both in theory and in practice. This leaves plenty of scope for the do-it-yourself constructor. A few examples follow.

1. Omission of $R20$ and $R21$ causes the final stage to function as a balanced current controlled circuit.
2. Open loop gain and DC adjustment of all stages are practically independent of the balanced power voltages, provided zeners $D1$ and $D2$ always draw a current of approximately 10 mA . The printed circuit board will accommodate the half watt resistors $R1$ and $R2$.
3. The T9/T10 transistors can be either complementary darlington pairs or discrete complementary power transistors. Components $R22$, $R27$, $R14 \dots R17$ and $T5 \dots T10$ must be chosen in accordance with the requirements of the other active elements in the circuit. Unfortunately, limited space prohibits full discussion of all possibilities.

The complete amplifier when powered by a balanced plus and minus 30 V source, will have an output of at least 40 W into an 8 ohm load, with a harmonic distortion of approximately 0.05% at 1 kHz . The gain is about 22. Some construction tips:

1. The PNP darlington (T9) can be chosen from the following selection: TIP 145 (60 V), TIP 146 (80 V), TIP 147 (100 V) and similar types; the NPN (T10) from TIP 140 (60 V), TIP 141 (80 V), TIP 142 (100 V) and the like. T9 and T10 can have a common sink with a 2°C/W thermal resistance.
2. Control P2 adjusts the quiescent current of the final stage to $25 \dots 50 \text{ mA}$. The exact adjustment procedure is described on page 530 of the May '76 issue of Elektor (nr. 13).
3. Zero offset control, P1, balances the amplifier output terminal (the R25/R24 junction) in the absence of an input signal. This adjustment requires a universal meter with a low DC millivolt range. The balancing effectiveness can be verified by reversing the meter polarity. It is recommended to verify the offset balance again when P2 has been re-adjusted.
4. Capacitor C3 must be bipolar, not an electrolytic.
5. The $2 \times 24 \text{ V}$ centre tapped power transformer and bridge rectifier must be capable of supplying $2 \dots 3 \text{ A}$.

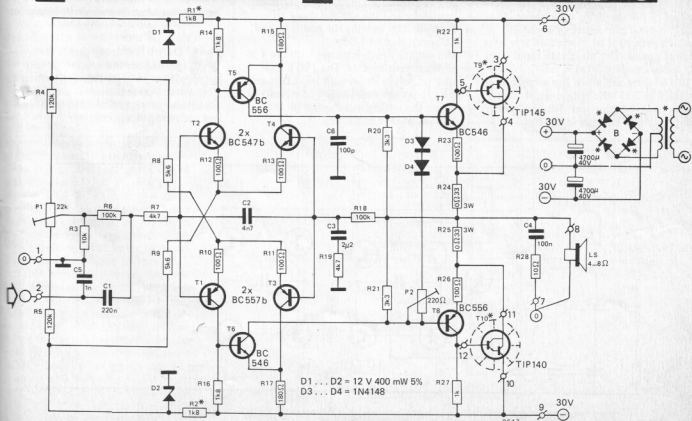
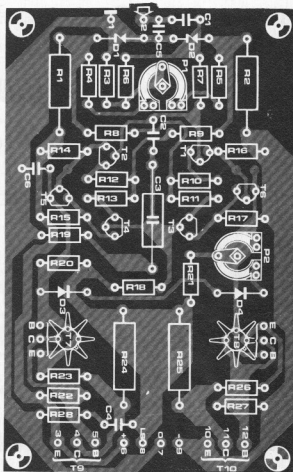
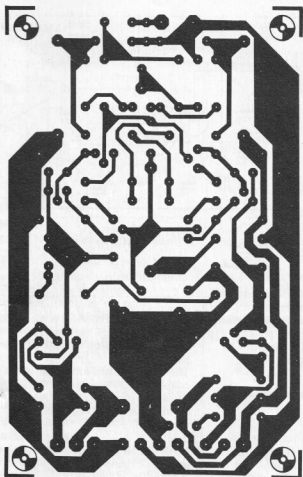

* see text

9647

90 200 MHz sample/hold adapter

91 hand-effect organ

92 voltage regulator for motorbikes

B. Paul

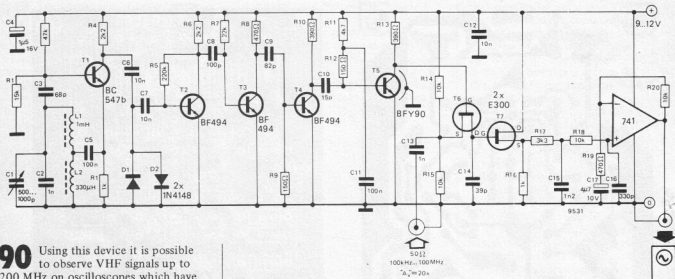

90 Using this device it is possible to observe VHF signals up to 200 MHz on oscilloscopes which have bandwidths as low as 100 kHz. The sample & hold circuit proper is T6. T7 operates as a heterodyning mixer, it will produce a zero beat when the input signal is at any harmonic multiple of the frequency being generated by T1. Assume that a 30 MHz signal with second and third harmonics must be inspected. When C1 is adjusted to produce a 10 kHz signal on the oscilloscope, the second harmonic would produce a 20 kHz signal and the third harmonic would produce a 30 kHz signal.

T2...T5 are required to sharpen the edges of the oscillator wave-shape. The circuit has a gain figure of about 20 which permits it to be used on low level input signals. The maximum input level is approximately 30 mV.

This adapter will allow the inspection of signals to 200 MHz. However, it does have its inconveniences: for one, it is impossible to determine the frequency

of the input signal. Also, when unstable signals are inspected, tuning may become a problem, since the signal drift is multiplied by the heterodyning process. An equivalent for the BC547B is the BC147B; an equivalent for the BF494 is the BF194.

91 Two voltage controlled oscillators (VCOs) are used in this 'organ', one to produce the tone and one to introduce vibrato. The oscillator frequency and the vibrato speed are controlled by moving the hands to and fro over a pair of LDRs.

The vibrato depth is preset with the 1 M preset potentiometer. The 100 k and 10 k presets in series with the LDRs are used to set the frequency and vibrato range; the setting will depend on the amount of ambient light.

To avoid hum if the unit is used under fluorescent lamps, the output from the LDRs is first passed through RC low-pass filters.

The VCOs are well-known emitter-coupled oscillators; the oscillation frequency depends on the current flowing through each lower pair of transistors.

Practically any general purpose small silicon NPN transistor can be used instead of the specified BC547.

92 Only a few components are needed for this electronic voltage regulator for motorbikes. Compared to conventional regulators it has the advantages of high reliability, long life and accurate voltage control.

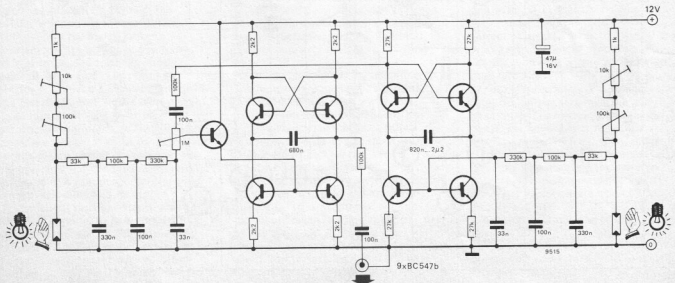

93 quiz selector

A. Schmeusser

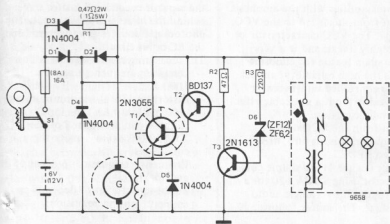

Values in brackets for 12 V version

* see text

As soon as S1 (ignition switch) is closed, the battery supplies current via D1. Current flowing through the base resistor R2 drives the power-darlington circuit (T2/T1) into saturation, so that the field winding of the dynamo is energised.

When the motor is running, the dynamo supplies the necessary current to the electrical installation via D2, blocking D1 and taking over from the battery. As soon as the output voltage becomes higher than the sum of the zener diode D6 and the base-emitter voltage of T3 (0.8 V), T3 will start to conduct. This pulls down the voltage on the base of T2, reducing the current into the field winding of the dynamo. The result is that the output voltage of the dynamo will drop. When the voltage drops below the zener voltage, T3 is blocked and the dynamo is 'opened up' again. This control system keeps the output voltage almost constant at 0.8 V more than the zener voltage.

Diodes D4 and D5 are included as a protection against negative spikes at these points. The battery is charged through diode D3 and limiting resistor R1.

Diodes D1 and D2 are power diodes, capable of carrying 25 amps. The reverse breakdown voltage should not be a problem: it can never be much more than the battery voltage. A suitable type would be the Siemens E1110 used in the prototype, if it is available . . .

After the circuit has been tested, it is a good idea to pour polyester resin over it: when this has hardened it is quite a good shock absorber. T1 will need a small heatsink; this should not be covered with polyester, but it must be well insulated from the frame of the bike!

The prototype was designed and built

for a 6 V electrical system, but if the values shown in brackets are used the circuit can be used in a 12 V system.

93 In a 'professional' quiz, some form of electronic detector is invariably used to determine which candidate is first to indicate that he thinks he knows the answer. The circuit shown here can be used to do the same job. Push-button S5 is under control of the quiz master. As long as he keeps this button depressed, none of the indication circuits will work. As soon as he releases it, the other circuits become operative. The first candidate to push his button (S1-S4) triggers the associated monostable (IC1-IC4). The monostable turns on an indicator LED and simultaneously blocks the other three monostables via N1. The monostable time is set at approximately 8 seconds; after this time the indicator lamp goes out and the other players can have a go. The quiz master can reset all monostables at any time with his 'override' button S5.

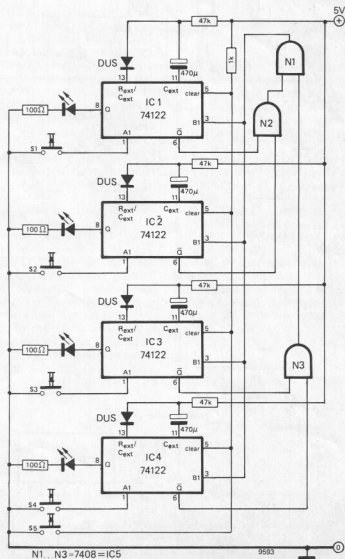

N1...N3=7408=IC5

9658

94 infra-redphone

94 The disadvantage of normal headphones is that they are connected to the main hi-fi equipment via a length of cable. This is unsightly, and people can trip over it. In recent years, a new solution to this old problem has been proposed: the infra-red transmission link. Although price, distortion and signal-to-noise ratio are all 10 - 20 dB worse than the original cable (yes, the price too . . .) there seems to be quite a demand for such a system. It is particularly popular as an 'extra' in TV sets — the price difference isn't so obvious there. The transmitter (figure 1) consists of

an audio preamplifier with pre-emphasis. The output from this is fed to the VCO, an XR 2207. The VCO characteristic of this IC is highly linear, and it is very stable. The main reason for choosing this IC was the high reliability: almost any voltage controlled multivibrator could be used without a noticeable effect on the overall distortion.

The output from the VCO drives a class-C amplifier; this, in turn, drives the infra-red LEDs.

The receiver (figure 4) is a simple coincidence detector using a TBA 120 (or a SO 41 P), followed by a single audio amplifier stage. The source follower at

the input is needed as a buffer stage behind the high impedance input. The photodiode doubles as varicap to tune the LC input circuit.

The measuring results were as follows:

- Operating frequency: approx. 100 kHz;
- Distortion: 3% at maximum output (500 mV) into 1 k. The input voltage to the modulator (pin 6 of the XR 2207) is 40 mV under these conditions;
- Frequency response: -6 dB at 15 Hz and 15 kHz;
- Signal-to-noise ratio: depends on ambient lighting conditions.

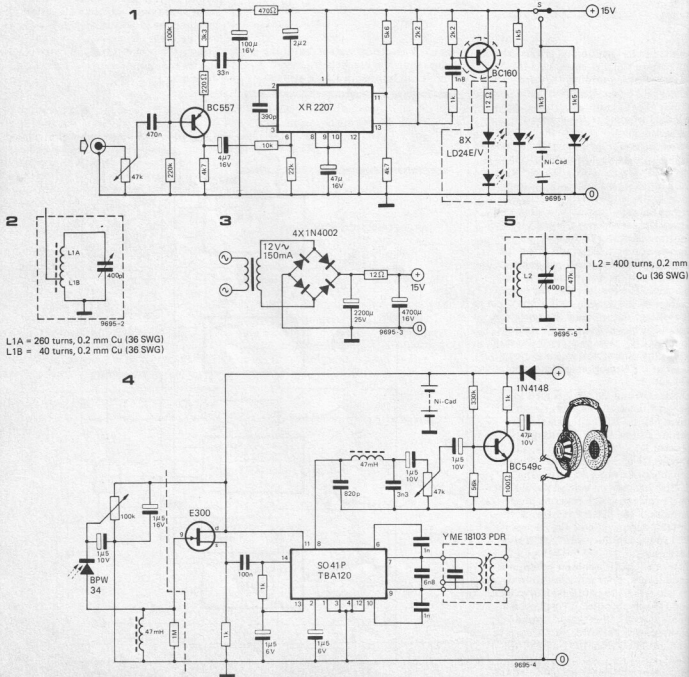

95 symmetrical regulated supply

96 stereo indicator

Since the infra-red LEDs are extremely expensive, an alternative solution should be of interest: replace the LEDs by ferrite rods... The circuit shown in figure 2 can be used instead of the 8 LEDs in figure 1. It is simply connected between the collector of the BC 160 and supply common. The coil is wound on an 8" (20 cm) ferrite rod with a diameter of about 1/2" (1 cm).

In figure 4, the receiver LED and associated components are replaced by the LRC circuit shown in figure 5. The coil is wound on a similar ferrite rod.

The tuning capacitors are adjusted until the greatest range is achieved (approximately 10', or 3 m). Be careful not to tune in to a harmonic of the transmitter - this will reduce the range drastically. A suitable power supply for the transmitter is shown in figure 3.

95 This symmetrical, variable, regulated power supply uses two voltage regulator ICs and one additional oamp. The maximum output current is 1 A; if one half of the supply runs into

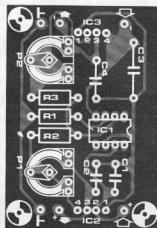
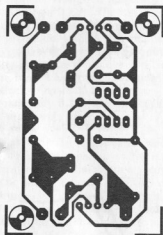

current limiting it automatically reduces the output voltage of the other half as well, so that the output voltage remains symmetrical.

Basically, the circuit consists of a positive regulator ($\mu A78G$) and a negative regulator ($\mu A79G$), each with its own output voltage adjustment (P1 and P2, respectively). This means that the circuit can also be set to give a double asymmetrical output. However, it is easier to understand the circuit if it is assumed that the output voltages are equal. In this case, the voltage at the R2/R3 junction is zero as long as the two output voltages remain equal and opposite. The output of the 741 will also be 0 V under these conditions, and all is well.

However, if the output from, say, the negative regulator drops for some reason, the voltage at the R2/R3 junction will swing positive. This causes the 741 output to swing negative, offsetting the common reference point to both regulators to such an extent that the output remains symmetrical.

The maximum input voltage is determined by the maximum supply voltage permissible for the 741; this is 36 V (2×18 V). The minimum output voltage is determined by the $\mu A78G$: 5 V.

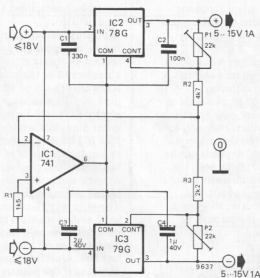

Note that single supplies using these two ICs are described elsewhere in this issue.

Fairchild application note.

96 This very simple circuit, giving an indication about the presence of stereo information in a music signal, is connected to the loudspeaker outputs of a stereo amplifier. The input level is adjusted with stereo potentiometer P1.

Both the R- and the L-signal are half-wave rectified via the base-emitter junctions of T1 and T2, respectively, producing 'pulsating' collector currents. If the L- and R- signals are equal (mono information), the collector voltages of T1 and T2 are equal, too, so neither of the LEDs will light up. If the signals are unequal (stereo) one or both of the LEDs will light.

The input level must be sufficiently high: the peak signal level at the base of T1 or T2, respectively, must be at least 0.6 V.

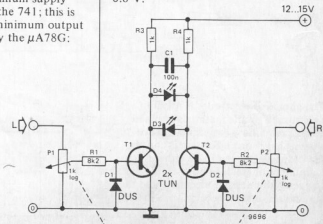

97 moisture indicator

98 super-bootstrap RC oscillator

97 One of the many problems facing millions of Britons this summer is: when must I water my garden?

Perhaps this little gadget will help. It makes use of the contact potential at the junction of two different conducting materials. When two rods of different materials are pushed into the soil close to each other, they will operate like a battery. The internal resistance of this 'battery' depends on the amount of moisture in the soil. If a sufficiently sensitive microammeter is connected between the rods, the deflection of the pointer will give a good indication of the amount of moisture in the soil.

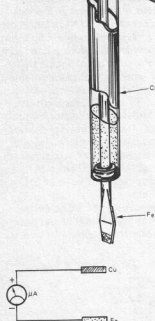
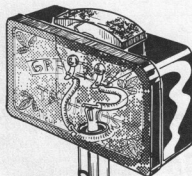

The choice of electrodes is mainly determined by the materials available. Some preliminary experiments have shown that if one electrode is copper, the other electrode can be either aluminium or steel. In both cases the copper is the positive electrode and the aluminium or steel is negative; a meter sensitivity of $50 \mu\text{A}$ f.s.d. will always be sufficient — if the electrode materials

are well-chosen, even $100 \dots 250 \mu\text{A}$ f.s.d. will do.

A possible construction is shown in the figure. If copper gas pipe is used, the second electrode (a piece of aluminium antenna rod or the blade of a steel screwdriver) can be mounted inside the pipe. Needless to say, the centre electrode should be insulated from the outer pipe, furthermore, it is a good idea to seal the gap between the inner and outer electrode at the top and bottom of the pipe with polyester resin or some other material that will give a strong and watertight seal.

The only way to calibrate the indicator is by adding resistors in parallel with the meter. This is only necessary if the pointer goes off the end of the scale in wet soil. A useful range should be obtained if the pointer just hits the end of the scale when the electrodes are immersed in a glass of tap water. A reading of less than one quarter of full scale will then mean that the soil is fairly dry, whereas a reading of more than three-quarters of full scale indicates an underground river.

After using the meter, always remember to wipe it clean and dry; never leave it pushed into the ground for long periods, as this will cause severe corrosion of the copper electrode.

98 Certain types of passive RC networks show a resonance effect, that is to say, their output voltage is slightly larger than the input voltage at a specific frequency. Two

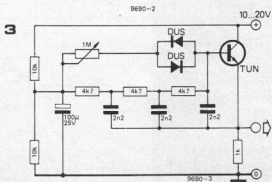
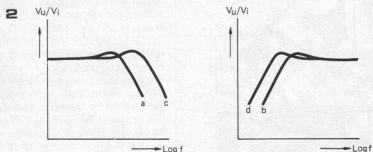
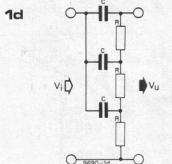
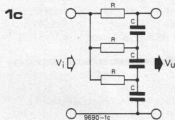
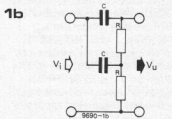
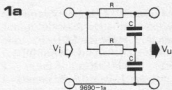

99 quad symmetrical supply 100 preset aerial amplifier

typical networks that demonstrate this effect are the lowpass filter of figure 1a and its highpass counterpart of figure 1b. Figure 2 indicates that both filters have a 6 dB per octave roll-off with a slight hump around the break frequency (curves a and b respectively). The 'gain' near the break point is roughly 0.8 dB. Since the slope changes from positive to negative this would indicate that somewhere near the break the phase angle is zero. Further RC networks can be added (figures 1c and 1d) which results in a more pronounced magnification. This is about 1 dB (figure 2c and 2d).

With these facts in mind, it should be possible to design an RC oscillator using an emitter follower whose gain is just below unity. Its emitter is connected to the input end of the filter network, and the base to the output end.

This arrangement would seem to satisfy the fundamental condition for sustaining oscillation, namely, an in-phase loop gain not less than unity at the critical frequency.

These theoretical considerations lead to the bootstrap-like circuit of figure 3, employing the selective network of figure 1d. With the RC parameters indicated the oscillation frequency is approximately 2 kHz. The variable resistor and the pair of reverse-parallel strapped diodes stabilise the amplitude. The variable resistor is set to a point slightly above the threshold of oscillation, in which case the oscillation is practically sinusoidal (distortion approximately 0.2%) and the amplitude at its minimum (approximately 0.5 V rms).

The distortion figure can be considered remarkably low, especially when it is remembered that the circuit employs just one transistor and a relatively crude amplitude stabilisation. The circuit illustrates how a simple theoretical consideration can be turned into a practical circuit.

99 Besides the set of symmetrical supply voltages (± 1 in the figure), it is often handy to have available a second set of symmetrical supply voltages (± 2 in the figure). These voltages are higher than the ± 1 voltages, and can supply only a relatively low current. With this circuit it is possible to obtain these auxiliary voltages from the same transformer windings as used for the main voltages.

The circuit operates as a symmetrical voltage doubler. Suppose the secondary of the transformer gives $2 \times V$ volts rms and that the diode threshold voltages are

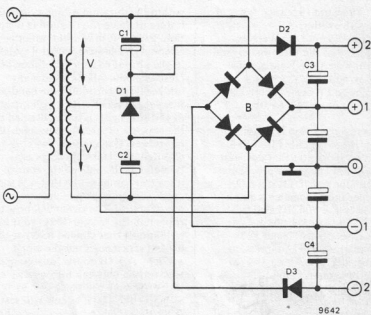

neglected. Then the voltages ± 1 are equal to $\pm V \times \sqrt{2}$. Capacitor C3 is charged from C1 via D2 during one half cycle; during the next half cycle C4 is charged from C2 via D3. Consequently the points ± 2 carry a voltage of $\pm 2V \times \sqrt{2}$ relative to supply common. For the practical circuit IN4000 series diodes can be used for D1, D2 and D3. The values of C1, C2 and C3 are 100 to 470 μF with a maximum voltage rating of at least $V \times \sqrt{2}$ volts.

100 This amplifier is intended for use in the 88-108 MHz VHF-FM band. It uses fixed input and output circuits.

Figure 1 shows how the amplifier is connected for use with a separate power supply cable; figure 2 shows the connections for supplying power via the coax cable. For optimum results, a trimming potentiometer of 2 k can be connected in series with the emitter resistor, and a trimmer of 10-40 p between the junction of the 22 p capacitor/0.15 μH choke coil and common. These controls are set for maximum S/N ratio. The gain is 12 to 15 dB at a noise figure of 2 dB.

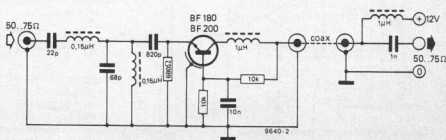
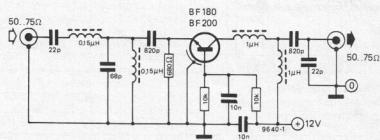

101 SSB exciter with HF compressor

101 There are two basic types of SSB exciter:

1. Filter-type circuits: these are expensive because of the filter and crystal required but have the advantage of being easy to adjust!
2. Phase-type and Weaver circuits: these are cheap but not so easy to align properly.

An intermediate solution is described here, using cheap ceramic filters in a high quality SSB exciter that does not call for awkward alignment procedures. The microphone signal (crystal mike or high impedance dynamic) is amplified and fed to the S042P balanced mixer. The 100 Ω preset potentiometer between pins 10 and 12 is set for maximum carrier suppression. The local oscillator uses a BF494 (or BF194) and a ceramic filter. The output signal from the S042P is DSSC (double sideband suppressed carrier). This signal is passed through a series filter chain and amplified in the two 703 opamps. The output from the second 703 is rectified and drives a second BF494; as soon as the base drive to this transistor exceeds about 0.5 V the transistor will start to limit the input signal to the first 703. This gives the desired gradual compressor function. It is fast (complete control

within the duration of one syllable) but it does not give rise to audible distortion. Even if it may seem rather peculiar to connect a shunting control system to the output of a ceramic filter, several measurements failed to show any noticeable distortion of the band-pass filter characteristic. The high quality of the SSB signal is only obtained at the expense of a reduced average output power. If maximum power is required, the 100 k preset potentiometer at the base of the control transistor can be set so that it is shorted out — this puts the gradual compressor out of action. The signal will now be clipped in the second 703, and it is well-known that clipped SSB has the highest efficiency (and the worst quality . . .). Of course, any compromise setting between high quality and high efficiency can be chosen by adjusting the 100 k trimmer to taste. Since the second 703 can always be driven into clipping, there is no guarantee that its output signal will be sufficiently clean. For this reason a second filter cascade had been added. The spectrum analyser photo shows the resulting selectivity, and the oscillator frequency relative to this. As can be seen from the photo, the result is USB (upper sideband). To convert this to

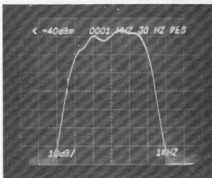

LSB, a mixer can be used: the exciter output and the n^{th} harmonic of the carrier are fed to this, and the mixer output is tuned to $(n-1)$ times the carrier frequency. All components can be left in circuit even if one wishes to switch back to USB: the only difference in that case is that the $(n-2)^{\text{nd}}$ harmonic of the carrier must be fed to the mixer instead of the n^{th} . This method for switching from USB to LSB and back has the advantage that it does not introduce zero-beat shift.

An experienced amateur should have no problems using the S042P, the filters and the 703s for reception as well as for transmitting. The IF can be injected at point 13 of the S042P (marked 'X' in the diagram).

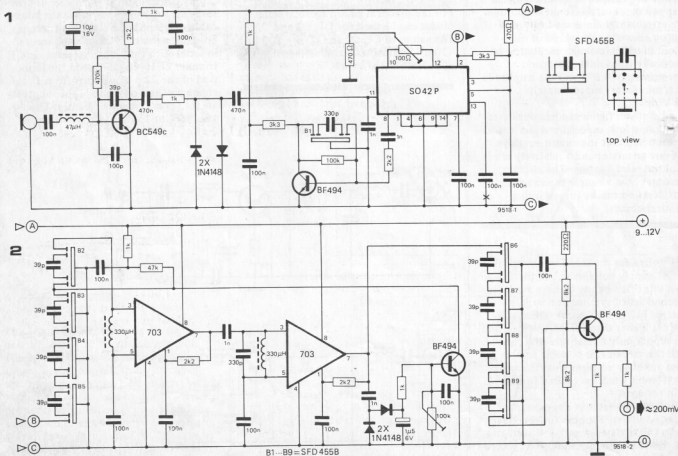

102 trawler band converter

102 There are quite a few interesting transmitters in the frequency band from 1.8 to 5.4 MHz: ships, aircraft, amateurs and broadcast transmitters in the tropics. With the aid of a simple converter this band can be received on a normal MW receiver.

The converter described here gives a certain amount of gain, so that it can be used with practically any normal receiver - even one with relatively poor sensitivity. FET T1 is included in a source follower circuit to reduce the loading of the LC tuned circuit at the input. The limiting amplifier in IC1 is used for the oscillator circuit, and the product detector is used as a mixer.

The output circuit (L4, C10, C11) is tuned to approximately 1.7 MHz (175 m). This is the frequency that the MW receiver is tuned to; it should be at one end of the MW scale. If necessary, C10 and C11 can be increased slightly to accommodate receivers with a shorter MW band.

The balanced mixer has the advantage that the local oscillator frequency does not appear at the output.

The output is designed for a 50 Ω load impedance (standard aerial input); if the receiver hasn't got an aerial input, about 4 turns run right around the receiver should give adequate coupling to the (ferrite) aerial. The output of the converter can be connected direct to this 'coil'.

It is impossible to say in advance what the results will be when the converter is connected to a portable in this way, for the following reasons:

1. The oscillators in portable radios usually radiate quite strongly, and this radiation is picked up by the converter. This results in 'dead' areas and beat frequencies, which sound, respectively, like areas where there is no reception and areas where there is nothing but interfering whistles.
2. The ferrite aerial of the portable receiver is still connected to this receiver. This gives the same effect as IF interference: any broadcast transmitter on or near the output frequency of the converter is mixed with the output from the converter.

Alignment of the converter is fairly simple, since the oscillator coil is fixed. C2B is turned until a transmitter at 5.4 MHz is received. C1B is now adjusted for maximum signal strength. After this adjustment, tune in to a transmission at 2 MHz and adjust L1A and L1B for maximum signal strength (slide one or both of these coils to and fro along the ferrite rod). Repeat the alignment procedure until no further improvement can be obtained.

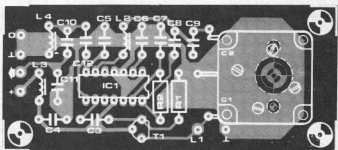
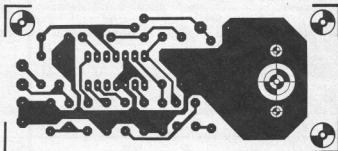
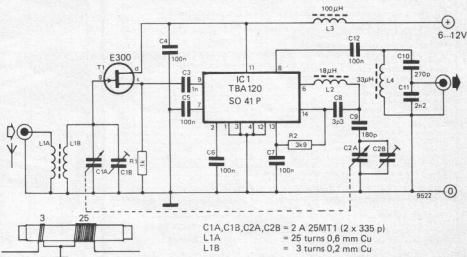

If an outdoor aerial is to be used, a short ferrite rod is sufficient for L1. However, if it is not certain that the receiver will be used with an outdoor aerial, it is advisable to use a long ferrite rod, say 8" long and 1/2" diameter. The printed circuit board is meant for a Toko tuning capacitor type 2A25MT1. This contains the necessary trimmers, which can be connected to the correct points. Only one set of trimmers are needed

Prototype measurement results:
 - conversion gain (50 Ω in and out): > 20 dB;
 - frequency range: 1.7 . . . 5.4 (or 6) MHz, according to the setting of C2B;
 - image frequency rejection: > 30 dB;
 These results cannot be guaranteed if a standard portable MW receiver is connected via the suggested 4 turns of wire round the case!

look out!

Have you already thrown away the mailing wrapper that this issue came in? If so, you'd better start digging in the waste paper . . .

As compulsive odd-corner-fillers, we couldn't resist the temptation to use the inside of the wrapper for one more little circuit. We intend to do something like this every month from now on. If you haven't got a subscription, you'll be missing one interesting item each month. Sorry, but we haven't got room for it in the magazine.

SPRING MADNESS BARGAIN SALE!

Echo-chambers, Variable time delay, Variable number of repeats. Use cartridge tape (not loop) giving very long life. More versatile than other units costing several times the price.....	£ 37.50
F.M. Tuners, 8-transistor chassis with stereo-decoder and L.E.D. indicator, Requires only 6 volts, 20 mA.....	£ 12.90
Stereo Amps, 3-watt, 8 ohm, With knobs and Escutcheon.....	£ 2.75
10-watt Amps, 12 volt D.C. 3/8" 15 ohm output.....	£ 4.40
Cartridges, Acos GP 104, Ceramic/Diamond.....	£ 1.50
Cartridges, Acos GP 101, Crystal/Sapphire/Compatible.....	£ 0.50
Speakers, 2" 8-ohm.....	£ 0.35
Speakers, Car Stereo, Both 5-watt, In cabinets.....	£ 0.20
Cynamic Tape Mikes with remote-control facility.....	£ 0.90
Crystal Tape Recorder Mikes.....	£ 0.60
Crystal Mike Inserts with brackets.....	£ 0.50
Indicators, 12-volt L.E.D. In Chrome Bezel.....	£ 0.35
*Bargain Bags 4lbs Caps/Resistors/Transistors/Diodes.....	£ 4.00
Controls, Volume/Preset (Rotary & Slider) Assorted 100.....	£ 2.50
Transistors, 20 NPN/PNP, All new and marked.....	£ 1.00
Transistors, 100 NPN untested.....	£ 1.00
Diodes, 100 Germanium untested.....	£ 0.50
Diodes, 100 Silicon untested.....	£ 0.50
Diodes, 100 Zener untested.....	£ 0.50
Pack 1 100 resistors, 100 ceramics, 100 diodes.....	£ 1.00
Pack 2 100 resistors, 100 ceramics, 100 polyethylene.....	£ 1.00
Pack 3 100 resistors, 100 S/Mica/Ceramic, 100 Polyester.....	£ 1.00
ALL ABOVE ITEMS PLUS 12½% VAT	
Fluorescent 12-volt Camping Lights, 21" 13-watt.....	£ 4.90
12" 8-watt.....	£ 3.90
Disco type 3-Channel flashing light units, Built-in mike, No connection needed to amp.....	£ 17.50
Multimeters, AC 0-1000V, DC 0-1000V, 0-100 mA, 0-150 kohm.....	£ 3.50
Multimeters, AC, 0-1000 volts, 5 Ranges, D.C., 0-1000 volts, 7 Ranges, D.C., current 0-10 µA to 0-500 mA, 4 ranges, Resistance 0-130 ohms, 0-50 megohms, 8 ranges, Decibels -20 to +62 dB.....	£ 14.50
Panel Meters, 0-30 µA, 4½" x 3½", Illuminating kit available.....	£ 3.50
Soldering Irons, 15-watt, Power Bit.....	£ 1.40
Special Switch Cleaner (with Snorkel).....	£ 0.50
Copper-clad Fibre Glass Board, Single-sided, Square foot.....	£ 1.00
Double-sided.....	£ 1.25
Fotokal Light sensitive spray for printed circuit making.....	£ 1.30
Developer for same.....	£ 0.30
Fabric Chloride for etching.....	£ 0.40
ALL ABOVE ITEMS PLUS 8% VAT	

D.F. MILWARD, 359 Alum Rock Road, POSTAGE: Below £ 10 50p
Tel. 021-327 2339, Birmingham B8 3DR. Above £ 10 Free

Cardis Limited

ELECTRONIC COMPONENT DISTRIBUTORS

P.O. Box 25 Canterbury Kent

Telephone: Canterbury (0227) 52139

Elektor

printed circuit boards and binders.

Prices as in this issue

Component kits and individual components available by return of post from stocks at Canterbury. All prices include VAT and P.+P.

741-B/14DIL	£0.22	E.1109	£6.08
7400	£0.15	7038A	£3.68
7401	£0.15	TBA231	£1.02
7405	£0.19	CA1310AE	£2.27
7447	£1.20	CA3080	£0.79
7473	£0.30	CD4011AE	£0.23
7495	£0.69	CD4017AE	£1.76
74121	£0.32	CD4049AE	£0.67
MM5314N	£4.77	TBA120	£1.24
SFE 6 mA (6 MHz Filter)	£0.90		
I/C EXTRACTOR	£0.55	NE555V	£0.65
I/C INSERTER	£1.40	2N3055	£0.54

Crystals for any requirement

PH 100 5-digit 30 MHz freq. counter £99.50

Above types are partial examples.

Write or phone for details.

7 p.m. to 9 p.m. phone Dover (0304) 812332

Stock List free on request.

DESIGNED BY TEXAS

30,000 ALREADY SOLD

Texan Amplifier as featured by PRACTICAL WIRELESS

SOLE U.K. DISTRIBUTORS — HENRY'S

Build it yourself for only

£32 KIT PRICE INC. VAT + £1.00 p&p
Built and tested £42.00 inc. VAT + £1.00 p&p

Build the Texan stereo amplifier, then you can be doubly proud! For a start, you'll own a superb home entertainment unit. And have had all the pleasure of doing it yourself, with the Henry's kit.

Look at the Texan specification

Incorporating fully integrated stereo preamp and power amp, with 6 IC's, 10 transistors, 6 rectifiers and zener diodes. Plus stabilised, protected circuitry, glass fib. pcb. Gardeners low-fielded, low line mains transformer, all facilities and controls. Slim design, chassis 14½" x 6" x 2" overall, 20 watts per channel RMS, less than 0.1% distortion at 1 kHz.

★ Can be built Stage by stage
★ Ask for leaflets 5.
★ Everything necessary supplied.
★ Full after sales service and guarantees.

TEXAN FM TUNER KIT £23.50
inc. VAT + 50p p&p

Built and tested £28.50 inc. VAT + 50p p&p

Build the matching Texan stereo tuner! Features advanced varicap tuning. Phase lock loop decoder. Professionally designed circuit. Everything you need is in the kit. From the glass fibre pcb to the cabinet itself. Excellent spec: 2.5 uV aerial sensitivity, 500 mV output (adjustable), Tuning range 87-102 MHz. Mains powered.

THE NATURAL FOLLOW-ON

Henry's latest
ELECTRONICS CATALOGUE

- over 5000 items — many new
- free 50p voucher inside every copy
- virtually everything needed by amateurs and professionals
- over 200 pages
- easy-to-use, complete alphabetical index
- section index
- everything at competitive prices

ONLY 50p

FREE to Educational Establishments when ordered on official headed notepaper 1001 pack

HENRY'S RADIO

All mail to: Henry's Radio
303 Edgware Rd. London W2

LONDON W2: 404/6 Edgware Road. Tel: 01-402 8381
LONDON W1: 231 Tottenham Ct Rd. (sales floor) Tel: 01-636 6681
*NOTTINGHAM: 94/96 Upper Parliament St. Tel: (0602) 40403
*READING, BERKS: 130/131 Friar Street. Tel: (0734) 583230
*HARROW: 190/4 Station Road. Tel: 01-863 7788
*CROYDON: 110 North End. Tel: 01-681 3310
*NEW STORES

Please Note: Mail Order Customers HENRY'S WILL CREDIT ANY VAT DOWN VAT OVERPAYMENTS

VIDEO SPORT



An up-to-the-minute game. Plugs into your own TV aerial socket. Switch on. And you're away! Choose your game — football, tennis or hole-in-the-wall. Absolutely safe. For you, your children. And your TV. Mains powered. List Price £42.50

HENRY'S PRICE £25.00 inc. VAT + 50p p&p

★ OVER 10,000 ALREADY SOLD

★ IDEAL GIFT

For this latest edition, we have made hundreds of changes and additions. Features now include:

The easy way to a PCB...

...the Seno 33 system!



The Dalo Pen!
The original fine-line etch resist marker. Simply draw onto the planned tracks on copper-clad board — new etching in minutes. Valve controlled ink dispensing for longer life. £1.50 for 1, £5.00 for 6, £9.40 for 12.

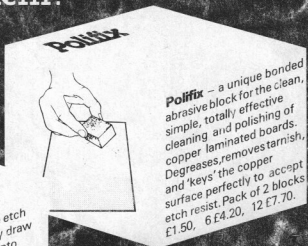

Polifix — a unique bonded abrasive block for the clean, simple, totally effective cleaning and polishing of copper laminated boards. Degreases, removes tarnish, and 'keys' the copper surface perfectly to accept etch resist. Pack of 2 blocks £1.50, 6 £4.20, 12 £7.70.



Seno etch resist transfer symbols for a truly professional finish!

Sharply defined, adhesive-backed symbols in easy-to-use strip form, adhere direct to copper laminate and offer total etch resistance. Presented in packs of 10 strips, each of different symbol. £2.00 per pack, £17.50 per 10 packs.

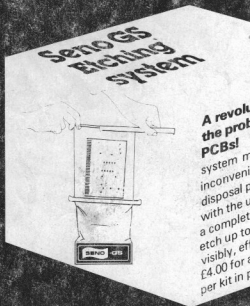

A revolutionary solution to the problems of etching PCBs! Unique sealed system minimises the risk, inconvenience, storage and disposal problems associated with the use of acid etchants — a complete kit designed to etch up to eight boards rapidly, visibly, effectively and SAFELY! £4.00 for a complete kit, £3.45 per kit in packs of 6.

Seno 33 — The Laboratory in a box

From your usual component supplier or direct from:

DECON LABORATORIES LTD.
Ellen Street, Portslade,
Brighton BN4 1EQ
Telephone: (0273) 414371
Telex: IDACON BRIGHTON 87443