

\$12.50

*Harley-Davidson*

# Panhead Service Manual

*1948-1957 Rigid*

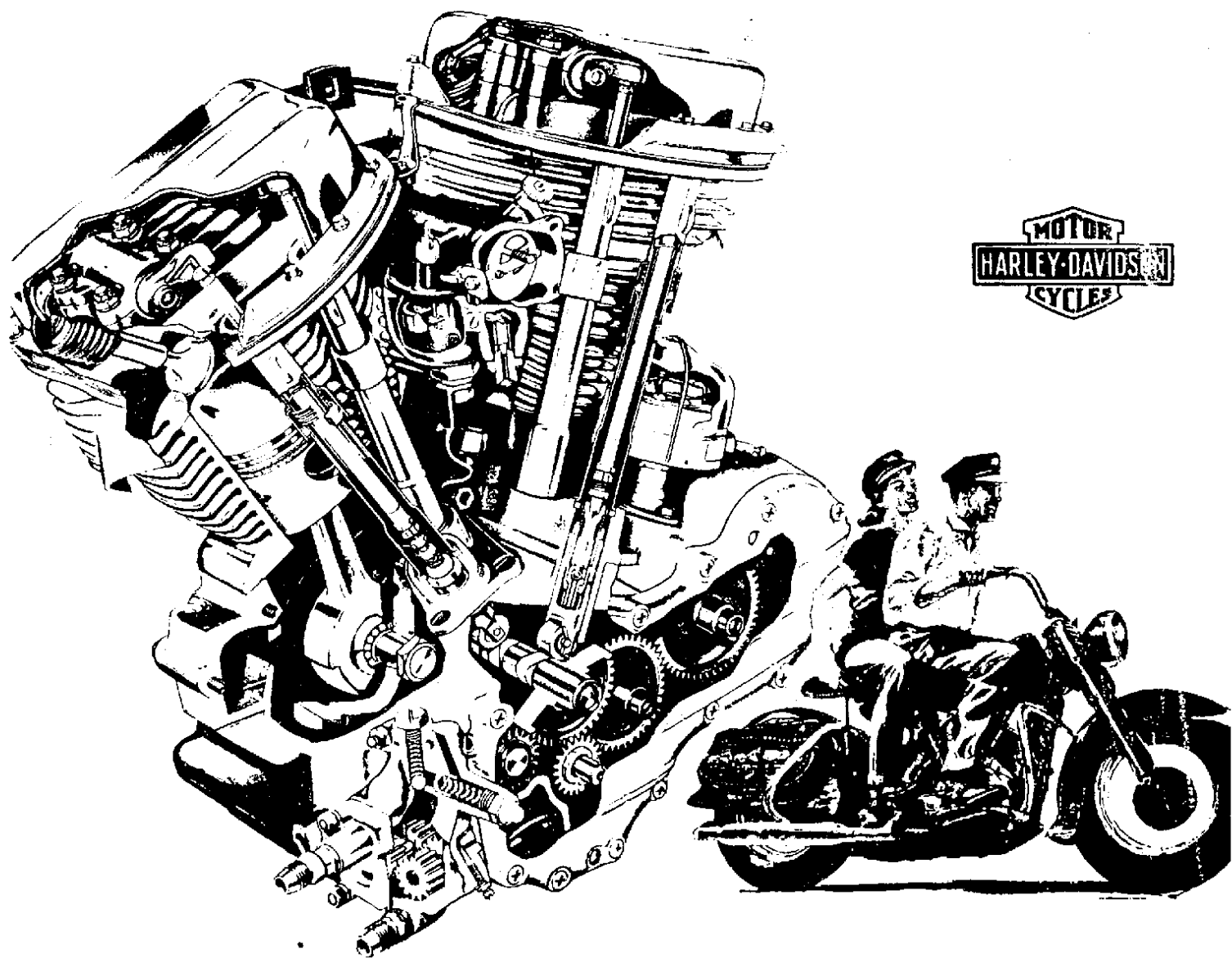



**T**his Service Manual is dedicated to attaining for Harley-Davidson motorcycle owners the highest degree of performance and satisfaction.

Except when a particular model or year model is indicated, the information in this manual applies to O.H.V. Twin Models back to 1948.

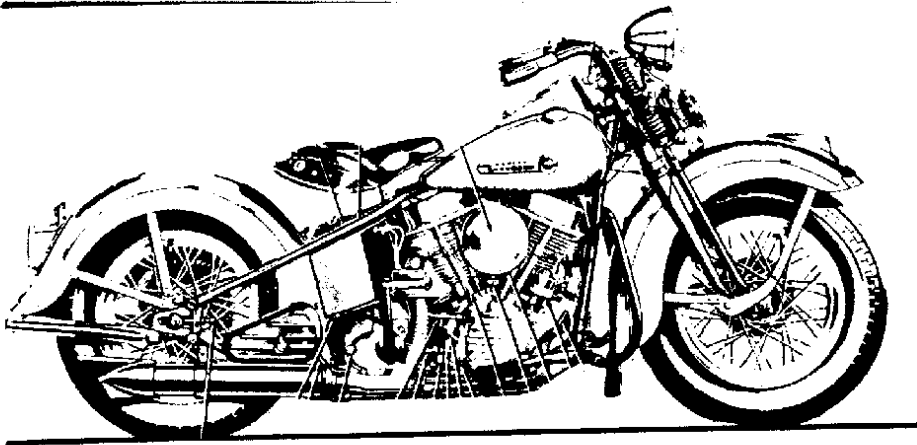

**Product**

General Specifications 1948-1954... 4  
 General Specifications 1955-1957... 6  
 Lubrication Chart ..... 8  
 Signal Lights ..... 9  
 Starting Engine ..... 9  
 Stopping Engine ..... 9  
 Running in New Engine ..... 9  
 High Speed Tips ..... 10  
**Trouble Shooting Charts** ..... 10  
   engine ..... 10  
   generator ..... 11  
   carburetor ..... 11  
   transmission ..... 11  
   brakes ..... 12  
 General Lubrication ..... 12  
 Lubrication Chart ..... 13  
 Servicing Air Cleaner ..... 14  
 Initial Servicing of New Motorcycle... 14  
   first 250 miles ..... 14  
   first 750 miles ..... 14  
   first 1500 miles ..... 15  
 Regular Interval Inspection & Maintenance ..... 15  
**Care & Lubrication of Drive Chain**... 16  
   adjusting drive chain ..... 16  
   adjusting front chain ..... 16  
   adjusting rear chain ..... 16  
   lubrication front chain ..... 16  
   lubrication rear chain ..... 17  
   repairing drive chain ..... 17  
 Clutch & gear shifter ..... 18  
 Compensating sprocket (early style)... 18

**Chassis**

**Wheels** ..... 20  
   general ..... 20  
   removal ..... 20  
   removal (side car) ..... 21  
   servicing wheel hubs ..... 22  
   replacing rear wheel sprocket ... 23  
   spoking wheels ..... 23  
   truing wheels ..... 24  
   removing & installing tires ..... 25

**Shop Data**

wheels ..... 26  
**Servicing Handlebar Controls** ..... 28  
   early model ..... 28  
   late model ..... 29  
**Removing & Installing Forks** ..... 29  
   springers ..... 31  
**Fork Frame & Handlebar Alignment**... 34  
   rough check for fork alignment... 34

rough check for frame alignment. 34  
 frame alignment diagram ..... 35  
 springer shock ..... 36  
**Glide Forks** ..... 37  
   general ..... 37  
   changing oil ..... 37  
   glide fork diagram ..... 39  
   glide fork diagram (adjustable) .. 40  
   disassembling fork sliders & tubes 41  
   adjusting steering damper ..... 41  
   adjusting fork trail (adjustable)... 42  
   disassembling front fork ..... 42  
   steering head bearings ..... 43  
   replacing slider bushings ..... 43  
   inspecting & servicing fork ..... 44  
   straightening fork tubes ..... 44  
   straightening fork stem & bracket assembly ..... 45  
   assembling fork ..... 46  
   assembling fork (adjustable) .... 47  
**Brakes** ..... 48  
   disassemble front brake (glide) .. 48  
   inspection & servicing (glide) ... 48  
   assembling front brake (glide) ... 48  
   adjusting front brake cable (glide) 48  
   adjusting front brake shoes (glide) 48  
   glide brake diagram ..... 49  
   springer brake diagram ..... 49  
   rear brake diagram ..... 50  
   adjusting rear & springer brakes. 51  
   servicing rear & springer brakes. 51  
**Servicing Saddle Spring Post** ..... 52

**Engines**

general ..... 54  
 engine diagram ..... 55  
 lubrication ..... 56  
 winter lubrication ..... 57  
 changing oil ..... 57  
 oil pressure signallight ..... 57  
 operating oil pressure ..... 57  
 oil filter ..... 57  
 pressure oil system ..... 58  
 return oil system ..... 59  
 engine repair procedure ..... 59  
 pressure oil system diagram ..... 61  
 return oil system (early) ..... 62  
 return oil system (late) ..... 63  
 disassembling cylinder & piston... 64  
 refinishing cylinders ..... 65  
 fitting piston rings ..... 66  
 connecting rod bushings ..... 67  
 straightening connecting rods ... 68  
 assembling cylinder & piston ... 69

**Shop Data**

cylinder reboring & piston fitting.. 70  
 pistons & rocker arms ..... 72

removing cylinder head assembly. 73  
 disassembling cylinder head ..... 73  
 replacing valve guides ..... 73  
 cylinder head diagram ..... 74  
 replacing valve seats ..... 75  
 grinding valve faces & seats ..... 75  
 lapping valve faces & seats ..... 76  
 assembling cylinder head ..... 76  
 adjusting tappets ..... 76

**Shop Data**

valve guides ..... 77  
 installing high lift cam ..... 78  
 intake valve guides ..... 79  
 valve guide sizes ..... 80  
 exhaust valve rotating mechanism 81  
 valve spring testing information.. 82  
 FLH valve springs ..... 83  
 hydraulic pushrods ..... 84  
 adjusting hydraulic pushrods .... 85  
 servicing hydraulic pushrods .... 86  
 tappet check valve servicing ..... 88  
 misc. clearances & oil pressure.. 89  
**Oil Pump** ..... 90  
   servicing oil pump ..... 90  
   installing oil pump ..... 91

**Shop Data**

oil control ..... 92  
 oil pump charges ..... 94  
 late oil pump ..... 96  
 oil pump flow diagram ..... 97  
**1948-1954 Lower End Diagram**..... 98  
**Disassembling Lower End** ..... 99  
   installing timing gears ..... 100  
   installing timing gear case cover. 100  
   1948-1954 gear & crankcase data procedures ..... 100  
   truing & sizing main bearing races ..... 101  
   fitting main bearings ..... 102  
   servicing flywheels & installing crankpan ..... 102  
   truing & sizing connecting rod lower races ..... 102  
   determining correct lower bearing fit ..... 103  
   assembling connecting rods & flywheels ..... 103  
   truing flywheels ..... 104  
   assembling crankcases ..... 105  
   installing generator ..... 106

**Shop Data**

removing & replacing pinion shaft gear ..... 107  
 crankcase drilling procedures ... 109  
 connecting rod roller & retainer size chart ..... 111  
 engine fitting specifications ..... 112  
 servicing pinion shaft rollers ... 113  
 pinion shaft assembly diagram... 114  
 1955-1957 oil pump diagram ..... 115

1953-1957 Valve Tappets & Guides... 116  
 1954-1957 Gear Case Diagram ..... 118  
 1954-1957 Gear Case Timing Cases. 119  
 1955-1957 Crankcase ..... 122

**1955-1957 Complete Lower End Procedures** ..... 122-130

**Shop Data**

engine fitting data '55 & later... 131

roller bearing roller guides .....132  
 identification of roller retainers..134

**Adjusting Carburetor** .....136  
 disassembling carburetor .....136  
 carburetor diagram .....137  
 cleaning & repairing carburetor..138  
 assembling carburetor .....139  
 air cleaner .....139  
 fuel strainer .....140  
 fuel tanks .....140

## Shop Data

servicing notes for carburetor...141  
 specification chart for carburetor.142  
 float bowl .....143  
 adjusting carburetor on engine ..144  
 carburetor conversions .....145  
 manifold .....146  
 carburetor specifications .....147

general .....148  
 clutch general .....151  
 adjusting foot clutch control ....151  
 adjusting hand clutch control ...151  
 adjusting clutch .....152  
 disassembling clutch .....152  
 cleaning & inspecting clutch ....153  
 assembling clutch .....154  
 disassembling starter .....155  
 cleaning & inspecting starter ....155  
 assembling starter .....155  
 disassembling starter clutch ....155  
 cleaning & inspecting starter  
 clutch .....155  
 assembling starter clutch .....156  
 starter diagram .....156  
 adjusting shifting linkage .....157  
 adjusting foot shifter cover ....157  
 replacing main drive gear oil  
 seal .....157  
 removing shifter cover .....158  
 disassembling shifter cover ....159  
 cleaning & inspection shifter  
 cover .....159  
 assembling shifter cover .....159  
 shifter cover diagram  
 (footshift) .....160  
 replacing shifter cover.....162  
 removing shifter forks.....162  
 disassembling shifter forks.....162  
 cleaning & inspection shifter  
 forks .....162  
 assembling shifter forks .....163  
 disassembling gear box .....163  
 counter shaft assembly diagram ..164  
 disassembling mainshaft .....165  
 disassembling main drive gear...166  
 assembling main drive gear .....167  
 assembling main shaft .....167  
 assembling counter shaft .....167  
 transmission vent screw .....168

## Electrical

wiring diagram for 1948 model ..170  
 wiring diagram for 1949-54 .....171  
 wiring diagram for 1955-57  
 (standard) .....172  
 wiring diagram for 1955-57  
 (radio special) .....173  
 Ignition Light Switch .....176  
 Button Switch .....177  
 Headlamp Dimmer & Horn Switch..177

**Headlamps** .....178  
 3 Brush 32E Generator Diagram...179  
 radio 2 brush generator diagram.181  
 trouble shooting & repairing  
 generator .....183  
 removing generator .....184  
 testing field coils & brush holders  
 assembled .....184  
 disassembling generator .....186  
 testing armature .....188  
 turning down commutator .....189  
 undercutting commutator .....189  
 reassembling generator .....189  
 assembling generator to engine..190  
 generator charging rate .....190  
 replacing generator brushes ....190  
 cleaning commutator .....190  
 lubricating commutator end  
 armature bearing .....191  
 cut out relay .....191  
 generator brush diagram .....192  
 current & voltage regulator ....193  
 fan cooled generator .....194  
 fan cooled generator diagram ...195

## Shop Data

fan cooled generator .....198  
 model 32E 2R radio generator  
 diagram .....199  
 model 48 3 brush fan cooled  
 generator diagram .....200  
 model 48 2 brush fan cooled  
 generator diagram .....201  
 model 51 '52 & later 2 brush fan  
 cooled generator diagram ....202  
 model 32E standard 3 brush  
 generator diagram .....203  
 model 52 standard 3 brush  
 generator diagram .....204

**Circuit Breaker Description** .....205  
 single contact point manual  
 advance .....205  
 double contact point manual  
 advance .....205  
 adjusting circuit breaker points..206  
 checking & adjusting ignition  
 timing .....206  
 circuit breaker diagram .....208  
 removing circuit breaker .....210  
 inspection & replacement of  
 parts circuit breaker .....210

**Ignition Coil** .....212

**Spark Plugs** .....213

## Shop Data

regulator service information ....215

**Battery** .....217

**Horn** .....218

## Miscellaneous

removing side car from  
 motorcycle .....222  
 attaching side car to  
 motorcycle .....222  
 side car wiring digram .....222

**Servicing Speedometer** .....223

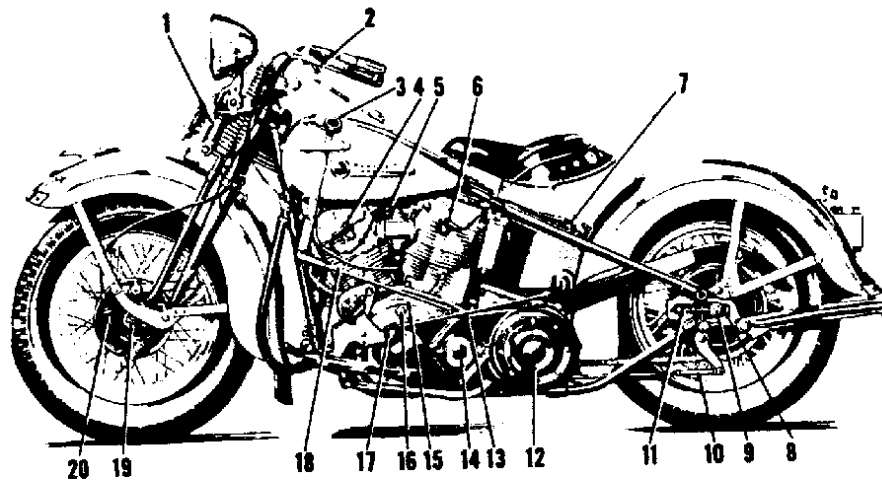

1948 Left Side View of OHV Model

- |                              |  |  |
|------------------------------|--|--|
| 1. Hydraulic Shock Absorber  | 9. Rear Axle Nut                         | 15. Engine (Serial) Number               |
| 2. Headlamp Dimming Switch   | 10. Rear Brake Rod Adjusting Clevis      | 16. Ignition Timing Inspection-Hole Plug |
| 3. Gear Shifter Lever        | 11. Left Side Rear Wheel Adjusting Screw | 17. Clutch Footpedal                     |
| 4. Front Spark Plug          | 12. Clutch Inspection-Hole Cover         | 18. Gear Shifter Rod                     |
| 5. Carburetor Choke Lever    | 13. Clutch Footpedal Rod                 | 19. Front Wheel Axle Nut                 |
| 6. Rear Spark Plug           | 14. Front Chain Inspection-Hole Cover    | 20. Front Wheel Brake Adjusting Sleeve   |
| 7. Positive Battery Terminal |  |  |
| 8. Brake Sleeve Nut          |  |  |

1948 - 1954

### GENERAL SPECIFICATIONS

MODEL	E and EL	F and FL
Type of Engine	61 Cu. In. O.H.V. Twin	74 Cu. In. O.H.V. Twin
Cylinder Bore	3 <sup>5</sup> / <sub>16</sub> "	3 <sup>7</sup> / <sub>16</sub> "
Stroke	3 <sup>1</sup> / <sub>2</sub> "	3 <sup>31</sup> / <sub>32</sub> "
Piston Displacement	60.32 Cu. In.	73.66 Cu. In.
Compression Ratio (Low compression engine)	E Model 6.5 to 1	F Model 6.6 to 1
Compression Ratio (High compression engine)	EL Model 7.0 to 1	FL Model 7.0 to 1
Horsepower (N.A.C.C. Rating)	8.77	9.44
Wheelbase	59 <sup>1</sup> / <sub>2</sub> "	59 <sup>1</sup> / <sub>2</sub> "

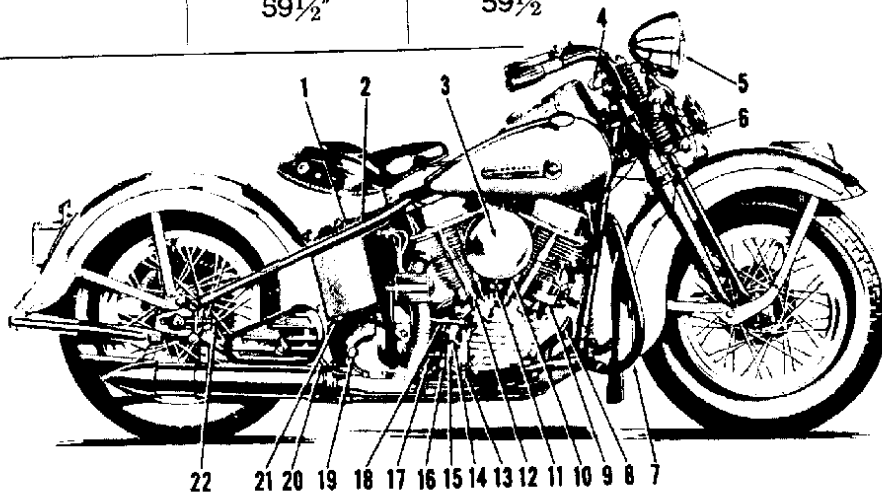

Figure 2 - Right Side View of OHV Model

1949-54

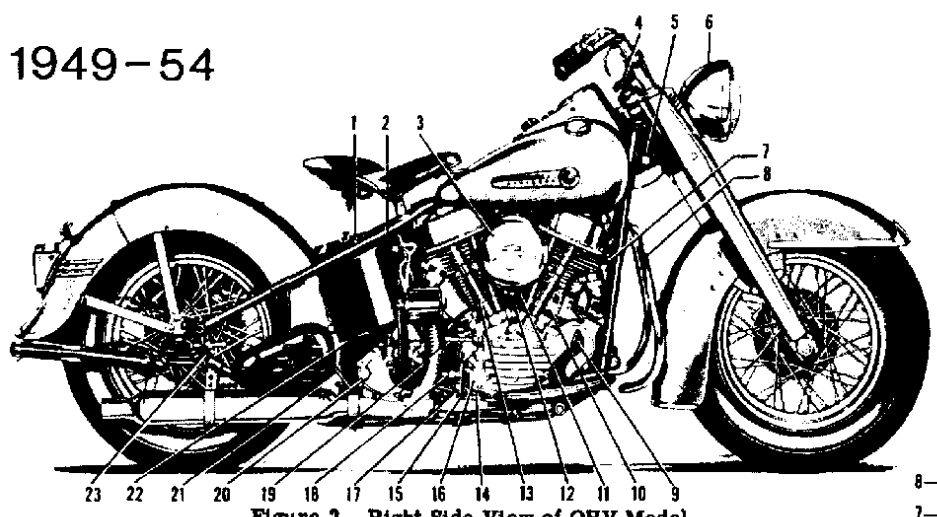

Figure 2 - Right Side View of OHV Model

- |   |   |   |
|---|---|---|
| 1. Negative (grounded) Battery Terminal | 9. Rear Wheel Brake Foot Pedal                              | 16. Oil Pump                              |
| 2. Oil Tank Cap with Gauge Rod Attached | 10. Ignition Circuit Breaker                                | 17. Stop Light Switch                     |
| 3. Carburetor Air Cleaner               | 11. Carburetor Bowl Drain Plug                              | 18. Oil Return Pipe from Scavenger Pump   |
| 4. Steering Damper Adjusting Knob       | 12. Gasoline Strainer                                       | 19. Oil Tank Vent Pipe                    |
| 5. Head Lock                            | 13. Valve Push Rod Cover                                    | 20. Transmission Oil Filler Plug          |
| 6. Head Lamp                            | 14. Adjusting Screw in Oil Pump Body for Front Chain Oiling | 21. Oil Supply Pipe to Feed Pump          |
| 7. Horn                                 | 15. Oil Pressure Indicating Light Switch                    | 22. Oil Tank Drain Plug                   |
| 8. Safety Guard (Extra Equipment)       |   | 23. Right Side Rear Wheel Adjusting Screw |

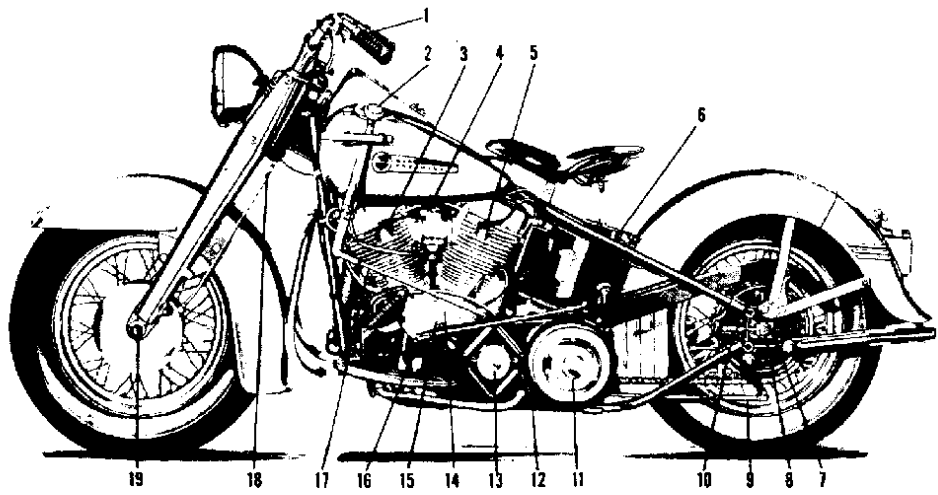
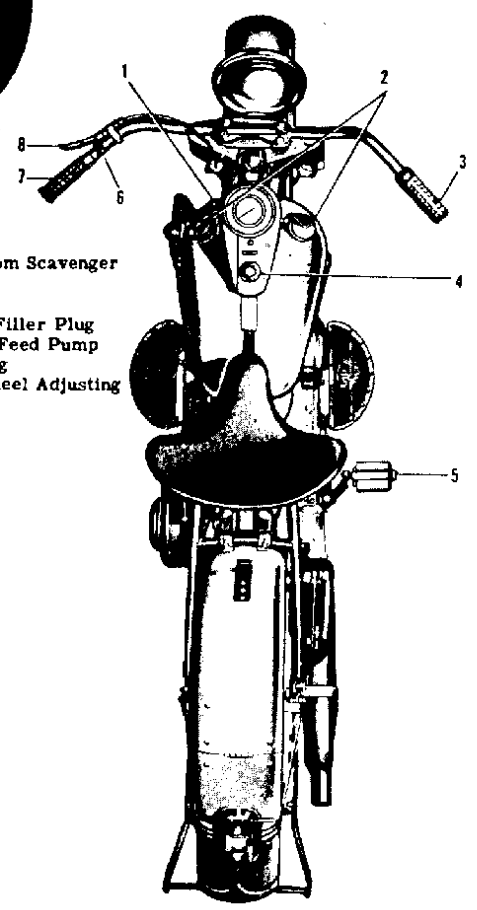

Figure 1 - Left Side View of OHV Model

- |                              |  |  |
|------------------------------|--|--|
| 1. Head Lamp Dimming Switch  | 9. Rear Brake Rod Adjusting Clevis       | 14. Engine (Serial) Number               |
| 2. Gear Shifter Lever        | 10. Left Side Rear Wheel Adjusting Screw | 15. Ignition Timing Inspection Hole Plug |
| 3. Front Spark Plug          | 11. Clutch Inspection Hole Cover         | 16. Clutch Foot Pedal                    |
| 4. Carburetor Choke Lever    | 12. Clutch Foot Pedal Rod                | 17. Gear Shifter Rod                     |
| 5. Rear Spark Plug           | 13. Front Chain Inspection Hole Cover    | 18. Front Wheel Brake Adjusting Sleeve   |
| 6. Positive Battery Terminal |  | 19. Front Wheel Axle Nut                 |
| 7. Brake Sleeve Nut          |  |  |
| 8. Rear Axle Nut             |  |  |

1. Gas Shut-off and Reserve Supply Valve Plunger
2. Gas Tank Cap (2)
3. Throttle Control Grip
4. Ignition - Light Switch
5. Starter Crank Pedal
6. Horn Button
7. Spark Control Grip
8. Front Wheel Brake Hand Lever

**GEAR RATIOS**

No. of Sprocket Teeth	*Fourspeed Transmission		†Threespeed Transmission	
	Solo	Sidecar	Solo	Sidecar
Engine Sprocket E 61 and EL 61	22	20	22	18
Engine Sprocket F 74 and FL 74	23	21	23	20
Clutch Sprocket	37	37	37	37
Countershaft Sprocket	22	22	22	22
Rear Sprocket	51	51	51	51
<b>Third Gear Ratio</b>				
E 61 and EL 61	4.78	5.28		
F 74 and FL 74	4.58	5.01		
<b>High Gear Ratio</b>				
E 61 and EL 61	3.90	4.29	3.90	4.76
F 74 and FL 74	3.73	4.08	3.73	4.29

**TIRE DATA**

	Front	Rear	Sidecar
<b>Solo - Rider Only</b>			
4.00 x 18 Tire	14 lbs.	16 lbs.	
5.00 x 16 Tire	12 lbs.	14 lbs.	
<b>Solo - Rider and One Passenger</b>			
4.00 x 18 Tire	18 lbs.	26 lbs.	
5.00 x 16 Tire	12 lbs.	16 lbs.	
<b>Sidecar - Rider and One Sidecar Passenger or 150 lb. Sidecar Load</b>			
4.00 x 18 Tire	20 lbs.	24 lbs.	14 lbs.
5.00 x 16 Tire	14 lbs.	16 lbs.	14 lbs.

\*With fourspeed transmission use "Third" gear when driving slowly and when accelerating. Cruise in high gear.

†Or threespeed and reverse transmission

The tire inflation pressures given are based on rider and passenger weight of approximately 150 lbs. each. When these loads are exceeded by 50 lbs. or more, increase tire pressure as follows: For each 50 lbs. of overload, increase pressure of rear tire 2 lbs.; front tire, 1 lb.; sidecar tire, 1 lb.



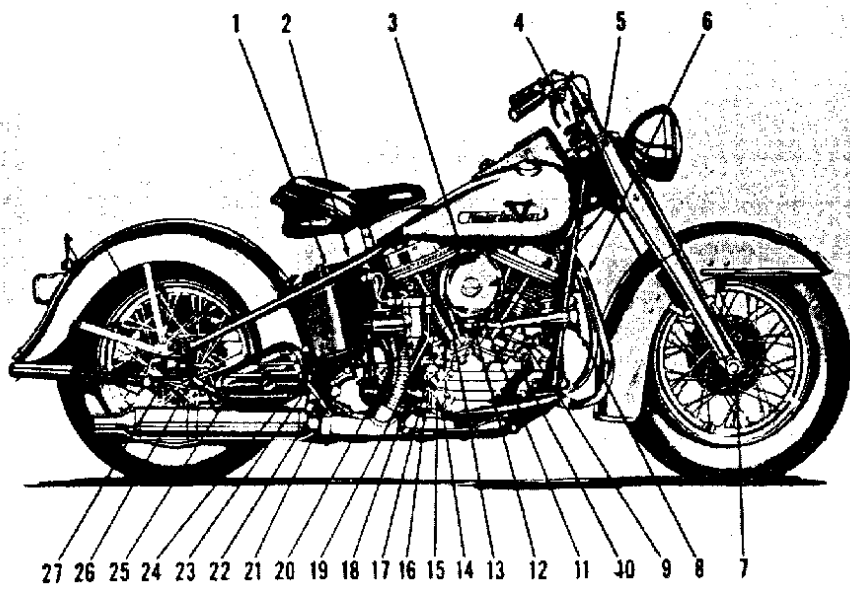

- |   |  |
|---|--|
| 1. Negative (Grounded) Battery Terminal | 14. Front Chain Oiler Adjusting Screw    |
| 2. Oil Tank Cap - Gauge Rod Attached    | 15. Oil Pump                             |
| 3. Carburetor Air Cleaner               | 16. Stop Light Switch                    |
| 4. Steering Damper Adjusting Knob       | 17. Oil Pressure Indicating Light Switch |
| 5. Head Lock                            | 18. Oil Return Pipe                      |
| 6. Safety Guard (Extra Equipment)       | 19. Oil Tank Vent Pipe                   |
| 7. Front Wheel Axle                     | 20. Oil Filter (Extra Equipment)         |
| 8. Horn Trumpet                         | 21. Transmission Oil Filler Plug         |
| 9. Ignition Circuit Breaker             | 22. Starter Crank                        |
| 10. Rear Wheel Brake Foot Pedal         | 23. Oil Supply Pipe                      |
| 11. Carburetor Bowl Drain Plug          | 24. Oil Tank Drain Plug                  |
| 12. Gasoline Strainer                   | 25. Tool Box                             |
| 13. Valve Push Rod Cover                | 26. Right Rear Wheel Adjusting Screw     |
|   | 27. Rear Wheel Axle                      |

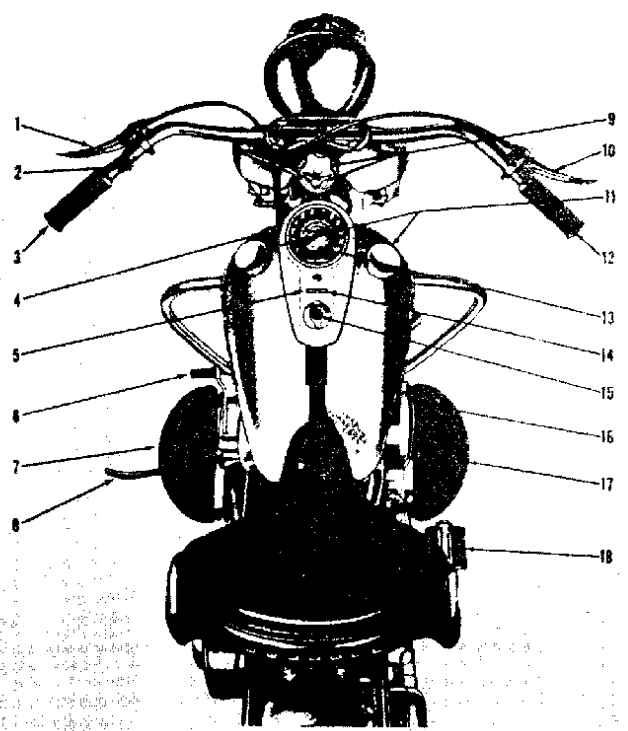

- |  |                                   |
|--|-----------------------------------|
| 1. Clutch Hand Lever                     | 9. Steering Damper Adjusting Knob |
| 2. Horn Button                           | 10. Front Brake Hand Lever        |
| 3. Spark Control Crip                    | 11. Gas Tank Cap (2)              |
| 4. Gas Shut-off and Reserve Supply Valve | 12. Throttle Control Grip         |
| 5. Generator Signal Light                | 13. Speedometer                   |
| 6. Foot Gear Shift Lever                 | 14. Oil Pressure Signal Light     |
| 7. Left Foot Board                       | 15. Ignition - Light Switch       |
| 8. Jiffy Stand                           | 16. Rear Brake Foot Lever         |
|  | 17. Right Foot Board              |
|  | 18. Starter Crank Pedal           |

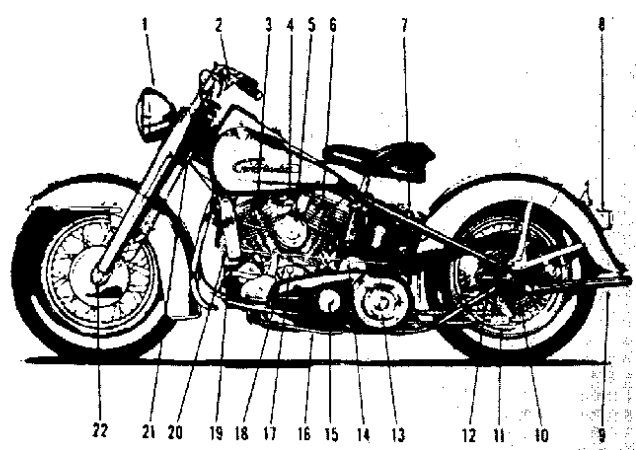

- |                                     |  |
|-------------------------------------|--|
| 1. Headlamp                         | 12. Left Rear Wheel Adjusting Screw        |
| 2. Headlamp Dimmer Switch           | 13. Clutch Inspection Hole Cover           |
| 3. Front Cylinder Spark Plug        | 14. Clutch Release Rod                     |
| 4. Carburetor Choke Lever           | 15. Front Chain Inspection Hole Cover      |
| 5. Horn                             | 16. Jiffy Stand                            |
| 6. Rear Cylinder Spark Plug         | 17. Ignition Timing Inspection Hole Cover  |
| 7. Positive Battery Terminal        | 18. Engine (Serial) Number                 |
| 8. Tail Lamp                        | 19. Foot Gear Shift Lever                  |
| 9. Rear Stand                       | 20. Hand Clutch Booster Spring             |
| 10. Rear Axle Nut                   | 21. Front Wheel Brake Adjusting Sleeve Nut |
| 11. Rear Brake Rod Adjusting Clevis | 22. Front Wheel Axle Nut                   |



The following chart outlines recommended Maintenance and Lubrication intervals after performance of service on a new motorcycle and the initial break-in period. Refer to Figure 1B-1 when using the chart.

**IMPORTANT:** To prevent over-greasing, use hand grease gun on all grease fittings.

### REGULAR LUBRICATION AND SERVICE INTERVALS CHART

REGULAR SERVICE INTERVAL	FIG. 1B-1 INDEX NO.	SERVICE	FIG. 1B-1 INDEX NO.	OIL	FIG. 1B-1 INDEX NO.	SERVICE
EVERY 1,000 MILES	15	Saddle Post	15	Clutch Hand Lever	24	Air Cleaner
	5	Saddle Bar Bearing	5	Brake Hand Lever	25	Battery
	23	Rear Brake Pedal	23	Clutch Control Cable	26	Rear Chain Adjust- ment
	20	Bearing	20	Front Brake Cable		
	7	Foot Shift Lever Bearing	7	Throttle Control Cable		
	12	Hand Clutch Booster Bearing	12	Spark Control Cable		
	21	Front Wheel Hub Thrust Bearing	21	Clutch Lever Rod Clevis		
		Rear Wheel Hub Thrust Bearing		Shifter Control Joints		
	4	Foot Clutch Pedal	4	Generator Bearing		
	14	Bearing	14	Rear Chain		
19	Compensating Engine Sprocket	19	Saddle Post Roller and Bolt			
EVERY 2,000 MILES					27	Oil Filter
					28	Fuel Strainer
					29	Tappet Oil Screen
					34	Front Chain Adjust- ment
					30	Front Chain Oiler Rear Chain Oiler
EVERY 5,000 MILES OR 1 YEAR (whichever comes first)					31	Circuit Breaker
					32	Spark Plugs
	7	Throttle Control Spiral			33	Hydraulic Fork Replace:
	6	Spark Control Spiral			24	Air Cleaner
	2	Front Wheel Hub (Center)			27	Oil Filter
13	Rear Wheel Hub (Center)				Time Ignition Switch Tires Adjust Brakes	
31	Sidecar Wheel Hub (Center)					
31	Circuit Breaker Camshaft					
EVERY 10,000 MILES						
EVERY 50,000 MILES		Repack Steering Head Bearings				
WEEKLY						Check Tires Check Battery

## INSTRUMENT PANEL SIGNAL LIGHTS

Red light marked "GEN" in center of instrument panel indicates whether or not generator is charging.

Red light marked "OIL" in center of instrument panel indicates whether or not oil is circulating.

*All Models:* When switch is turned "ON" preparatory to starting engine, both lights should go "ON." (Exception: When switch is turned "ON" immediately after engine has been primed by cranking, oil pressure signal may not light, but will light after a few seconds. This is due to oil pressure built up by cranking and is most likely to be noticed in cold weather.)

With engine started and running at a fair idling speed, both lights should go "OFF." At slow idling speed or under about 20 miles per hour road speed in high gear, generator signal will normally flash "ON" and "OFF" because at that speed generator output is very low and unsteady.

Should generator signal fail to go "OFF" at speeds above approximately 20 miles per hour, generator is either not charging at all or its output is not up to normal and it should be inspected at once.

Should oil circulation signal fail to go "OFF" at speeds above idling, it is most likely due to: empty oil tank; oil supply badly diluted, or using very light grade of oil and pump not building up normal pressure; if freezing weather, oil feed pipe may be clogged with ice or sludge. However, it may be: grounded oil signal switch wire, faulty signal switch; or oil pump in bad order. Give due attention to oil supply and, if signal still does not operate normally, check to see if oil returns to tank. To do this, remove oil tank cap and, with engine running, look for pulsating return of oil. A small flashlight is an aid in making this check. If oil is returning, motorcycle can be driven slowly, but no further than absolutely necessary before checking and servicing oiling system. If oil is not returning, do not drive further before having the fault corrected, as engine is likely to be damaged.

## STARTING ENGINE

When starting engine, gear shifter handle must be in neutral and clutch fully engaged. Spark should be fully advanced or nearly so.

Note: Choke lever positions are as follows:

*O.H.V. Engine:* Choke lever all the way down, choke is "closed"; choke lever all the way up, choke is "open."

*Side Valve Engine:* Choke lever all the way up, choke is "closed"; choke lever all the way down, choke is "open."

*All Models:* Starting Cold Engine: Set choke lever in fully-closed position, open throttle wide, and with ignition switch "OFF," prime cylinders by operating starter crank once or twice.

Then, with choke lever set  $\frac{1}{4}$  or  $\frac{1}{2}$  closed in mild weather,  $\frac{3}{4}$  or fully closed in extremely cold weather, and throttle slightly open, turn ignition switch "ON" and start engine with vigorous strokes of starter.

**CAUTION:** It is only in extremely cold weather that engine may start best with choke fully closed, and even then, it will have to be moved from this position immediately after engine starts. Under no conditions will engine continue to run with full choke.

As soon as engine starts, set throttle for moderate idling speed while warming up or until ready to set motorcycle in motion.

As engine warms up and misfires due to an over-rich mixture, gradually move choke lever toward open position. After engine has thoroughly warmed up, move choke lever to fully open position.

*Starting Warm Engine:* This applies to engine half way between hot and cold. Move choke lever to  $\frac{1}{4}$  closed position and with throttle closed, operate starter once or twice. Then, with throttle  $\frac{1}{4}$  to  $\frac{1}{2}$  open, turn ignition switch "ON" and operate starter. Soon after engine starts, choke lever should be moved back to fully open position. Remember: This procedure calls for having throttle part way open during starting strokes after switch has been turned "ON."

*Starting Hot Engine:* If engine has been shut off for only a brief period and is at about normal running temperature, it is not necessary to use choke lever. Simply close throttle, turn ignition switch "ON" and operate starter. With some engines, depending on carburetor adjustment, hot starting is more dependable if starter is given one stroke before turning ignition switch "ON."

When a hot engine does not start readily, that is, with two or three starter strokes, it is usually due to an over-rich (flooded) condition, and the proper procedure then is to open throttle wide so more air can enter, closing it quickly as engine starts.

## TO STOP ENGINE

Stop engine by turning ignition switch "OFF." If engine should be stalled or stopped in any other way than with switch, turn switch "OFF" at once to prevent battery from being discharged through circuit breaker points.

Don't idle engine unnecessarily with motorcycle standing.

## RUNNING IN NEW ENGINE

Don't run new motorcycle faster than 35 miles per hour the first 250 miles; 40 miles per hour the second 250 miles; 45 miles per hour (sidecar) or 50 miles per hour (solo) the next 500 miles. Avoid running at or near top speed for long distances below 2000 miles.

After a new motorcycle has been run 500 to 1000 miles it needs to be thoroughly checked over and any loose screws and nuts tightened. Particular attention must be given to those that secure engine and transmission; also to wheel mounting socket screws. See that this attention is given.

Both chains should be checked for ample lubrication.

## HIGH SPEED TIPS

Develop the habit of frequently snapping throttle shut for an instant when running at high speed. This draws additional lubrication to pistons and cylinders and helps cooling.

In cold weather run engine slowly until it is thoroughly warmed up, to avoid possible damage to piston rings, pistons and other parts before oil is warm enough to circulate freely.

A motorcycle run long distances at high speed must be given closer than ordinary attention to avoid overheating and possible consequent damage. Engine must be kept well tuned, especially as concerns valve seating, good compression, spark plugs and ignition timing. Carburetor should be adjusted moderately rich, rather than too lean. This applies particularly when motorcycle is equipped with handlebar windshield and legshields.

## TROUBLE CHART

### Engine

Note: Too frequently, spark plugs and or ignition coil are thought to be defective when engine starts hard, runs irregularly, or fails to start.

Sometimes when a spark plug fails to function normally, it is the result of an accumulation of dirt on plug core which becomes a conductor when damp or wet, allowing spark to jump from cable terminal to plug base, instead of across electrodes in combustion chamber. Under such a condition, wiping plug core clean with a dry rag will allow plug to function normally.

An ignition coil suspected of being defective may only need new spark plug cables installed. Cable insulation eventually deteriorates and sometimes cracks at the point where cable enters coil case. Spark may then jump from cable to cable packing nut (on coil case) instead of across electrodes in combustion chamber, especially if cables are damp or wet.

#### *If engine starts hard:*

1. Spark plugs in bad condition, or partially fouled.
2. Spark plug cables in bad condition and "leaking."
3. Circuit breaker points out of adjustment or in need of cleaning.
4. Battery nearly discharged.
5. Loose wire connection at one of battery terminals or at coil or circuit breaker.
6. Carburetor not adjusted correctly.

7. Defective ignition coil.
8. Defective condenser.

#### *If engine starts but runs irregularly or misses:*

1. Spark plugs in bad condition, or partially fouled.
2. Spark plug cables in bad condition and "leaking."
3. Spark plug gap too close.
4. Circuit breaker points out of adjustment or in need of cleaning.
5. Condenser connections loose.
6. Defective ignition coil.
7. Defective condenser.
8. Battery nearly discharged.
9. Loose wire connection at one of battery terminals or at coil or circuit breaker.
10. Intermittent short circuit due to damaged wiring insulation.
11. Water or dirt in fuel system and carburetor.
12. Gasoline tank cap vent plugged and tank air bound.
13. Carburetor not adjusted correctly.
14. Weak or broken valve springs.

#### *If engine fails to start, it may be due to one or more of the following conditions:*

1. Gasoline tank empty.
2. Gasoline valve shut off.
3. Gasoline line clogged.
4. Discharged battery or loose or broken battery terminal connection. Check by turning light switch "ON."
5. Fouled spark plugs.
6. Spark plug cables in bad condition and "leaking."
7. Badly oxidized ignition circuit breaker points.
8. Circuit breaker points badly out of adjustment.
9. Loose wire connection at one of battery terminals or at coil or circuit breaker.
10. Defective ignition coil.
11. Defective condenser.
12. Clutch slipping and starter not turning engine over.
13. Sticking valves, or tappets too tight.
14. Engine flooded with gasoline as a result of over-choking.

#### *If a spark plug fouls repeatedly:*

1. Too cold a plug for the kind of service or for type of engine.
2. Piston rings badly worn or in bad condition otherwise.
3. Oil pump improperly adjusted—oil pressure too high.
4. O.H.V. Engine—intake valve spring cover oil return line clogged with carbon or sludge. One or more push rod cover cork washers in bad condition or push rod covers not seating properly against cork washers.

#### *If engine preignites:*

1. Excessive carbon deposit on piston head or in combustion chamber.

2. Too hot a spark plug for the kind of service or for type of engine.
3. Defective spark plugs.

***If engine overheats:***

1. Insufficient oil supply, or oil not circulating.
2. Leaking valves.
3. Heavy carbon deposit.
4. Carburetor high speed adjustment too lean.
5. Ignition timing too late.

***If engine detonates:***

1. Unsuitable fuel (octane rating too low).
2. Heavy deposit of carbon on piston head and in combustion chamber (decreases combustion space, thereby increasing compression ratio. The higher the compression ratio, the higher the octane rating of fuel required).

***If oil does not return to oil tank:***

1. Oil tank empty.
2. Scavenger pump gear key sheared.
3. Oil feed pump not functioning.

***If engine uses too much oil:***

1. Breather valve incorrectly timed.
2. Oil pressure too high—readjust oil pump.
3. Piston rings badly worn or in bad condition otherwise.
4. O.H.V. Engine—oil return line clogged with carbon or sludge. One or more push rod cover cork washers in bad condition or a push rod cover not seating properly against its washer.
5. Chain oiler adjusting screw adjusted for an excessive amount of oil.

***Excessive vibration:***

1. Cylinder bracket loose or broken.
2. Engine mounting bolts loose.
3. Broken frame.
4. Front chain badly worn, or links tight as a result of insufficient lubrication.
5. Transmission and/or transmission sub-mounting plate loose in chassis.

## **Generator**

***If generator does not charge:***

1. Brushes badly worn.
2. Brushes sticking in holders.
3. Relay, or current and voltage regulator, not grounded.
4. Defective relay or current and voltage regulator.
5. Commutator dirty or oily.
6. Positive brush holder grounded.
7. Generator "relay" terminal grounded.
8. Loose or broken wire in generator-battery circuit.
9. Broken field coil wire or loose terminal (both coils).

10. Commutator shorted.
11. Defective armature.

***If generator charging rate is below normal:***

1. Regulating brush not properly adjusted.
2. Current and voltage regulator not properly adjusted.
3. Broken field coil wire or loose terminal (one coil).
4. Commutator worn and not turning true with shaft—throws brushes at high speed.
5. Commutator dirty or oily.
6. Brushes gummy and sluggish in holders.
7. Defective armature.

## **Carburetor**

***If carburetor floods:***

1. Float set too high.
2. Float valve sticking.
3. Float valve and/or valve seat worn or damaged.
4. Dirt or other foreign matter between float valve and its seat.
5. Carburetor float not located correctly in bowl—may be binding.

## **Transmission**

***If transmission shifts hard:***

1. Bent shifter rod.
2. Clutch dragging slightly.
3. Transmission oil too heavy (winter operation).
4. Shifter forks (inside transmission) sprung as a result of using too much force when shifting.
5. Corners worn off shifter clutch dogs (inside transmission)—makes engagement difficult.

***If transmission jumps out of gear:***

1. Shifter rod improperly adjusted.
2. Shifter forks (inside transmission) improperly adjusted.
3. Shifter engaging parts (inside transmission) badly worn and rounded.

***If clutch slips:***

1. Clutch controls improperly adjusted.
2. Insufficient clutch spring tension.
3. Worn and/or oil soaked friction discs.

***If clutch drags or does not release:***

1. Clutch controls improperly adjusted.
2. Clutch spring tension too tight.
3. Friction discs gummy.
4. Clutch key ring badly worn.

***If clutch chatters:***

1. Clutch disc rivets loose.
2. Clutch sprung disc too flat.

(Continued on next page)

## Brakes

*If brake does not hold normally:*

1. Brake improperly adjusted.
2. Brake controls binding as result of improper lubrication, or being damaged.
3. Brake linings impregnated with grease as result of overgreasing wheel hub and/or brake operating shaft.
4. Brake linings badly worn.
5. Brake drum badly worn and/or scored.

## GENERAL LUBRICATION

Refer to Lubrication Chart

### Special Instructions

Note: If predominating service conditions are either wet or muddy, or very dusty, the 750 and 1500 mile greasing intervals should be reduced to 500 and 1000 miles respectively.

- 15—Every 5000 miles, or at least once a year, pack generator commutator end bearing with high melting point grease (Harley-Davidson grade "A" grease). See "Lubricating Commutator End Armature Bearing."
- 16—Lubricate front wheel brake handle lever and control cable every 750 miles or whenever operation of brake indicates lubrication is necessary.
- 17-21—Twice a year, or whenever operation of grips indicates lubrication is necessary, remove grips and clean parts, then apply grease (Harley-Davidson "Chassis" grease) and reassemble. See "Servicing Handlebar Controls."
- 18—If engine is equipped with air cleaner, wash with gasoline or solvent, and reoil, at least each time engine oil tank is drained and refilled. Service more frequently under dusty conditions; daily under extremely dusty conditions. See "Servicing Air Cleaner."
- 19—Drain engine oil tank and refill with fresh oil at least every 2000 miles. In dusty service, and in winter weather, change oil oftener. See "Engine Lubrication," and very carefully read complete information given.
- 20—Pack steering head bearings with high melting point grease (Harley-Davidson grade "A" grease) every 50,000 miles, or whenever there is occasion to remove rigid fork for repair or replacement of parts. See "Removing and Installing Forks,"
- 22—Remove filler plug and check transmission oil

level every two weeks or every 1000 miles, whichever comes first, and add oil if necessary. Fill to level of filler opening. See "Transmission Lubrication."

**CONTROLS:** To keep controls working freely, all control joints which are not provided with grease fitting should be oiled regularly with oil can, particularly after washing motorcycle or operating in wet weather. Spark, throttle and front brake control wires should also be oiled at ends of control wire housings near circuit breaker, carburetor and front brake respectively.

**DRIVE CHAINS:** (See "Lubricating Drive Chains,"

**CIRCUIT BREAKER CAM:** Apply a very light coating of grease to cam every 1000 miles.

**SPEEDOMETER:** Every 15,000 miles lubricate speedometer core. This necessitates removing speedometer head, disconnecting core housing from transmission and removing core. Place about a tablespoonful of special speedometer core lubricant in one hand and feed core through the grease and into the housing. Under no circumstances should housing be filled with grease. See "Removing and Installing Speedometer Head and Drive Core."

**SIDECAR:** Four grease fittings are provided. One at each end of frame rear cross tube (brake cross shaft bearings); one on brake side cover (brake operating shaft); one on wheel hub. Lubricate hub at 1500 mile intervals; other bearings at 750 mile intervals. Oil sidecar brake linkage regularly with oil can.

Be careful about over-greasing wheel hubs, brake operating shafts and front wheel brake cover bushing, as excess grease working out of these bearings or bushings not only develops a messy condition, but is also likely to get onto brake linings, which will greatly reduce efficiency of brakes.

# LUBRICATION CHART

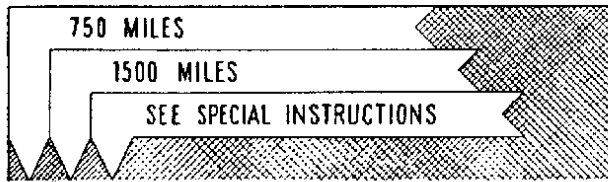

- 1 Front Wheel Brake Operating Shaft
- 2 Front Wheel Brake Cover Bearing
- 3 Rocker Plate (left side)
- 4 Front Wheel Brake Shackle
- 5 Fork Spring Rods
- 6 Clutch Footpedal Bearing (later models do not have this fitting)
- 7 Saddle Bar
- 8 Saddle Post
- 9 Rear Wheel Brake Operating Shaft
- 10 Rocker Plate (right side)
- 11 Rear Wheel Brake Footpedal
- 12 Rear Wheel Brake Crossover Shaft
- 13 Rear Wheel Hub
- 14 Front Wheel Hub
- 15 Armature Bearing (commutator end)
- 16 Front Wheel Brake Handlever
- 17 Spark Control Grip
- 18 Air Cleaner
- 19 Engine Oil Tank
- 20 Steering Head Bearings
- 21 Throttle Control Grip
- 22 Transmission

+ Indicates grease fitting. Wipe fittings clean before connecting grease gun.

### Type of Lubricant to be Used

- COLUMN A**—Chassis grease (Harley-Davidson "Chassis" grease).
- COLUMN B**—High melting point grease (Harley-Davidson grade "A" grease).
- COLUMN C**—Engine Oil.
- O.H.V. ENGINE:** Use Harley-Davidson "Medium Heavy" oil above +10° F.; Harley-Davidson "Light" oil when predominating temperature is +10° F. or colder.

If winter weather becomes so extremely cold that "Light" oil congeals in tank, add just enough kerosene to keep oil fluid.

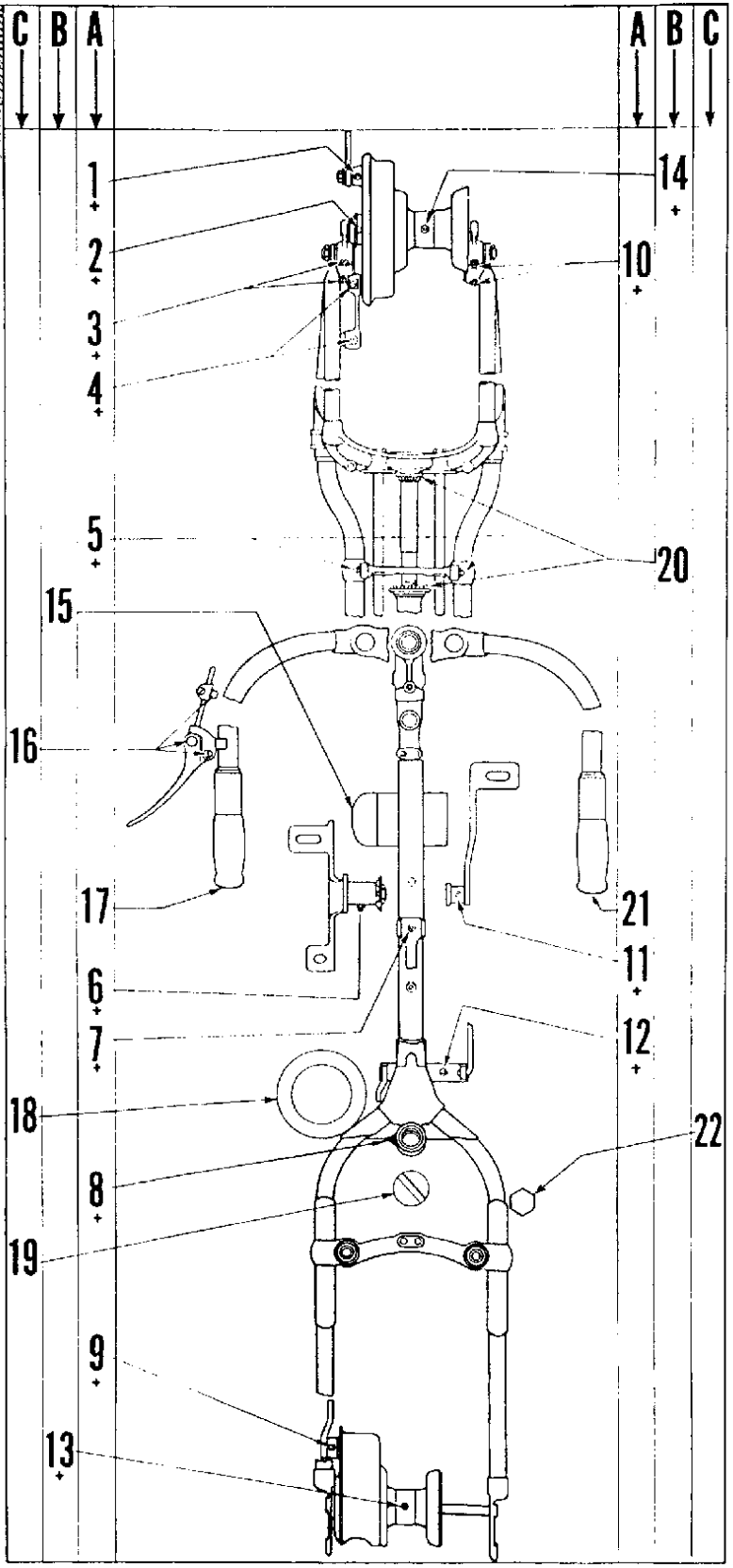

ILLUS. 1

## SERVICING AIR CLEANER

### Mesh Pack Type Cleaner

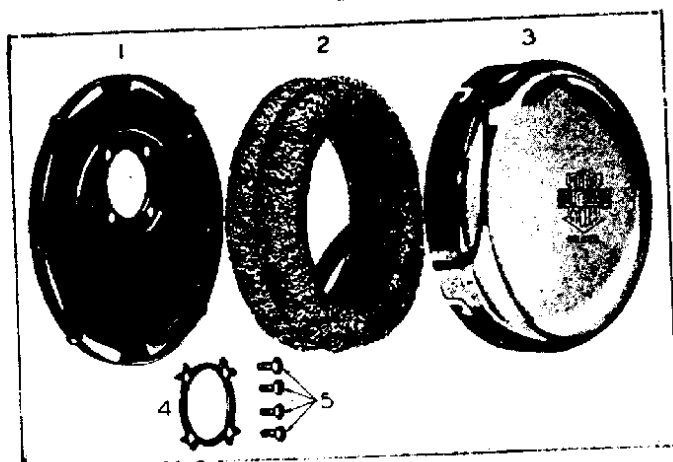

ILLUS. 2  
AIR CLEANER DISASSEMBLED (MESH PACK TYPE)

1. Air cleaner back plate.
2. Air cleaner mesh with support.
3. Air cleaner cover.
4. Air cleaner mounting screw lock.
5. Air cleaner mounting screws.

In normal service on hard surface roads, it is important that the air cleaner metal mesh be removed, washed thoroughly in gasoline or kerosene (or solvent), and then saturated with same grade of new oil as used in engine at least once every 1000 miles. In dusty service this attention should be given more frequently and in extremely dusty service every 100 miles or at least once a day.

To remove air cleaner cover, press inward and turn counter-clockwise. After mesh pack has been cleaned in gasoline or kerosene (or solvent), dip it in engine oil and allow excess oil to drain off, then reassemble and attach mesh pack assembly and cover by reversing removal operations. Cover must be attached with drain hole at bottom.

### Oil Bath Type Cleaner

A few motorcycles are in service equipped with an oil bath type air cleaner.

Clean and refill air cleaner oil cup at least each time engine oil tank is drained and refilled. Service frequently under dusty conditions.

Remove oil cup and baffle, thoroughly clean them and refill to indicated level with same grade of new oil as used in engine. Do not fill oil cup above indicated oil level as a higher level will restrict passage of air through cleaner and upset carburetion to the extent that engine may not start at all, or at best run very irregularly. The effect is the same as running with choke partially or fully closed.

When reassembling, observe that oil cup gasket is in place and make sure oil cup and baffle are properly seated against gasket and secured to cleaner housing. Careless assembly is likely to result in an oil leak between cup and cleaner housing and possibly a lost cup.

Occasionally, at time of servicing oil cup, complete cleaner should be removed from motorcycle and immersed for a time in a bucket of gasoline or kerosene (or solvent). Cleaner element, which cannot be removed from housing, must be thoroughly flushed to wash out accumulated dirt. After flushing, dry thoroughly (use an air hose if available) and apply a few squirts of engine oil to inside of cleaner element, using oil can.

Note: Observe instructions on air cleaner body.

## INITIAL SERVICING OF NEW MOTORCYCLE

### At First 250 Miles

1. At the first 250 miles, check front chain to make sure it is receiving required amount of oil for ample lubrication. If necessary, readjust chain oiler. See "Lubricating Drive Chains."
- Note: If motorcycle is equipped with rear chain oiler, instructions that apply to checking front chain lubrication, also apply to rear chain.
2. Check adjustment of chains. Readjust if needed.

### At First 750 Miles

1. Drain oil tank and refill with fresh oil. Thereafter, in average service change oil at intervals not exceeding 2000 miles. In extremely dusty serv-

ice, or when service is exceptionally hard, also in winter weather, oil must be changed at much shorter than normal intervals. See "Engine Lubrication."

2. Check level of oil in transmission and add oil if needed. Use same grade of oil used in engine. See "Transmission Lubrication."
3. Lubricate all points indicated for 750 mile attention on Lubrication Chart.
4. Oil all control joints, namely, clutch, gear shifter, brakes, front brake control wire, and spark and throttle control wires at ends of their respective housings.
5. If motorcycle is equipped with air cleaner, inspect and service if needed. See "Servicing Air Cleaner."

6. Check adjustment of chains and readjust if needed. Again, check lubrication of front chain and readjust chain oiler if found necessary. Clean and lubricate rear chain.
7. Check adjustment of brakes. Readjust controls if needed.
8. Check wheel mounting socket screws and tighten if needed. These screws must be kept very tight.
9. Check axle nuts and fork rocker plate stud nuts for looseness.
10. Check level of battery solution and add distilled water if needed. See that terminals are clean and connections tight.
11. Inspect all wiring connections and tighten any found loose. Check switches, lights, etc.
12. Check carburetor-manifold cap screws and manifold nuts.
13. Road test motorcycle to check carburetor adjustment and all-around performance.

### At First 1500 Miles

1. Check condition of oil in tank to determine if oil change is needed.
2. Check level of oil in transmission and add oil if needed. Use same grade of oil used in engine. See "Transmission Lubrication."
3. Lubricate all points indicated for 750 mile attention on Lubrication Chart.
4. Lubricate wheel hubs at 1500 mile intervals as indicated on Lubrication Chart.
5. Oil all control joints, namely clutch, gear shifter, brakes, front brake control wire, and spark and throttle control wires at ends of their respective housings.
6. Check adjustment of chains. Adjust if needed. Again, check lubrication of front chain. Clean and lubricate rear chain and check for broken rollers, loose pins or cracked side plates.
7. Check adjustment of gear shifting control. Adjust if needed.
8. Check adjustment of clutch and clutch control. Adjust if needed.
9. Check adjustments of brakes and brake controls. Adjust if needed.
10. Check all nuts, bolts and screws and tighten any found loose. Particular attention should be given to engine mounting bolts, cylinder head bracket bolts or nuts, transmission mounting stud nuts, and wheel mounting socket screws.
11. Check front and rear wheel for loose or broken spokes and rim damage.
12. Check level of battery solution and add distilled water if needed.
13. Engine should be given a complete tune-up including: Checking circuit breaker points, ignition timing, valve tappets, spark plugs, draining and flushing carburetor bowl, cleaning and flushing gasoline strainer, carburetor adjustment, and cleaning muffler outlet. Service air cleaner if motorcycle is so equipped.

14. Road test motorcycle to check carburetor adjustment and all-around performance.

Preceding three service jobs conclude what is considered initial servicing. Further servicing should be given according to schedule of "Regular Interval Inspection and Maintenance," which follows below.

### REGULAR INTERVAL INSPECTION AND MAINTENANCE

After schedule of initial servicing of new motorcycle has been completed, this maintenance schedule is then to be followed at regular intervals not exceeding 1500 miles.

1. Check condition of oil in tank to determine if oil change is needed.
2. Lubricate all points indicated for 750 mile attention on Lubrication Chart.
3. Lubricate wheel hubs at 1500 mile intervals as indicated on Lubrication Chart.
4. Oil all control joints, namely, clutch, gear shifter, brakes, front brake control wire, and spark and throttle control wires at ends of their respective housings.
5. If motorcycle is equipped with air cleaner, inspect and service if needed. See "Servicing Air Cleaner."
6. Remove rear chain, check for broken rollers, loose pins or cracked side plates, and then clean and lubricate as per instructions under "Lubricating Drive Chains." Check front chain for ample lubrication. Adjust chains.
7. Flush chain oiler passage as explained under "Lubricating Drive Chains."
8. Check clutch and clutch control adjustments. Readjust if needed.
9. Check brakes. Readjust controls if needed.
10. Check all nuts, bolts, and screws and tighten any found loose.
11. Check wheel mounting socket screws and tighten if needed. These screws must be kept very tight.
12. Check axle nuts and fork rocker plate stud nuts for looseness.
13. Check front and rear wheel for loose or broken spokes and rim damage.
14. Clean and flush gasoline strainer.
15. Remove carburetor bowl drain plug and flush bowl.
16. Check level of battery solution and add distilled water if needed.
17. Inspect all wiring connections. Check switches and lights.
18. Completely tune up engine, including: Checking circuit breaker points, ignition timing, valve tappets, spark plugs, carburetor adjustment, and cleaning muffler outlet.
19. Note that generator and oil pressure signal lights, in switch panel, go out when engine is running above idling speed.



20. Road test motorcycle to check carburetor adjustment and all-around performance.

Once every 5000 miles, or at least once a year (if total yearly mileage is less than 5000 miles), lubricate commutator end bearing of generator with high melting point grease (Harley-Davidson grade "A" grease).

## CARE AND LUBRICATION OF DRIVE CHAINS

### Adjusting Drive Chains

Inspect the adjustment of chains at least every week and adjust them if necessary. Adjustment of front chain can be checked through inspection hole provided in chain guard. Chains must not be allowed to run loose enough to strike guards or other chassis parts, because when that loose, they cause motorcycle to jerk when running at low speed, and there is excessive wear of chains and sprockets. The rear chain requires more frequent adjustment than front chain. As chains stretch and wear in service, they will run tighter at one point on the sprockets than at another. Always check adjustment at the tightest point and adjust chains at this point so that they have about 1/2-inch free movement up and down, midway between sprockets. Do not adjust tighter because running chains too tight is even more harmful than running them too loose.

Inspect chains occasionally for links in bad condition. If any are found, make repairs or renew the chain. The rear chain can be taken apart and removed after locating and taking out the spring locked connecting link. The front chain is not, however, originally provided with such a connecting link and whether or not one has at sometime been installed in making repairs, it will be necessary to remove the engine sprocket before chain can be taken off.

### To Adjust Front Chain

Loosen the four stud nuts and one cap screw underneath transmission. This permits moving transmission backward or forward by means of adjusting screw at rear of transmission on right side. Turn adjusting screw to right to tighten chain—to left to loosen chain. When chain is correctly adjusted, securely tighten stud nuts and cap screw and recheck chain, as tightening stud nuts and cap screw sometimes changes chain adjustment. Also check transmission mounting plate bolts occasionally and keep them tight.

Adjusting front chain changes the adjustment of rear chain, therefore, rear chain must also be adjusted.

Moving transmission to adjust front chain, also affects adjustment of gear shifter and clutch controls. Therefore, each time front chain is adjusted, these controls will need to be adjusted or at least their adjustment will have to be checked. See "Checking and Adjusting Clutch Control," and "Checking and Adjusting External Shifter Control."

### To Adjust Rear Chain

Remove rear axle nut and lock washer and loosen brake sleeve nut. Also loosen rear wheel adjusting screw lock nuts (one on each side of frame).

Turn adjusting screws to move rear wheel as necessary to correctly adjust chain. Assuming that wheel was correctly aligned the last time chain was adjusted, turning each screw an equal number of turns will maintain alignment.

When correct adjustment of chain is attained, securely tighten brake sleeve nut, rear axle nut and adjusting screw lock nuts. Then recheck chain adjustment, as tightening brake sleeve nut and axle nut sometimes changes chain adjustment.

Check alignment of wheel in chassis. This can be done by measuring the distance from inner side of chain to tire rim. For 5.00" x 16" tire rim, the distance should be approximately 1-3/16", and for 4.00" x 18" tire rim, the distance should be approximately 1 5/8". Distance between chain and rim should be checked at four equidistant points around rim, and if it happens to be out of true sideways to any appreciable degree, this will have to be taken into consideration. If measurement indicates wheel is out of alignment in chassis, it must be corrected, and of course, chain adjustment will have to be rechecked.

After adjusting rear chain, rear brake may be found too tight. Check and adjust if necessary. See "Adjusting Rear Wheel Brake."

## LUBRICATING DRIVE CHAINS

### Lubricating Front Chain

Front chain is automatically lubricated by engine oil pump. Chain oiling is adjustable and occasional readjustment may be needed to meet lubrication requirements of varied operating conditions.

As nearly everyone knows through experience, the good performance and life of a front chain depends entirely upon its ample lubrication. The quantity of oil required for ample lubrication is very slight. However, oiling must be constant. If oiling fails for a period of only a few hours or a few hundred miles, especially when operating at high speed, chain is likely to be ruined. Initial oiling adjustment is set at the factory as closely as possible to normal service requirements; however, the quantity of oil involved is so small, initial adjustment cannot always be trusted as final. Standard factory setting of chain oiler adjusting screw (illus. 3) is as follows: O.H.V. Models—1 full turn open; A 1/16" washer and required number of .002" washers are placed under screw head so that when screw head bottoms against washers point of screw is the specified number of turns off its seat.

At the intervals specified under "Initial Servicing of New Motorcycle," and "Regular Interval Inspection and Maintenance," remove inspection hole cover from chain guard and make a very close inspection of chain. If chain appearance

raises the least doubt as to its getting ample lubrication, add one or two more .002" washers under head of chain oiler adjusting screw. A well lubricated chain not only has an oily surface, but is also clean and free of discoloration. If chain has a brownish hue, and rusty appearance at side and center plates, it is under-lubricated even though the surface may be oily.

Since the quantity of oil involved is very small, the opening through which oil bleeds to chain is regulated by adjusting screw to a very small orifice. Sediment and gummy matter accumulated in oil supply deposits in and around this orifice and gradually decreases the oil supplied to chain. In other words, a chain that has been lubricating perfectly the first 2000 miles may run short of oil the second 2000 miles. Therefore, even though inspection indicates chain is amply lubricated, it is advisable at intervals of approximately 2000 miles, to loosen the chain oiler adjusting screw, and back it up about two turns. Operate this way a few miles and then turn screw back down moderately tight against its adjusting washers. This procedure flushes away accumulated sediment and restores oil orifice to its original size.

The same result can be accomplished if compressed air is available, by completely removing screw and washers, flushing opening with gasoline and blowing out. When this procedure is followed, care must be taken not to lose any of the thin washers under screw head, otherwise when screw is installed, it will not have the same adjustment as it did before being removed.

Following the above recommendations will go a long way toward eliminating chain failure.

If it is definitely determined that chain is getting an excessive amount of oil, remove one or more thin washers from under head of chain oiler adjusting screw. It is advisable to remove only one washer at a time and inspect chain again after motorcycle has been run approximately another hundred miles to determine whether or not further adjustment is needed.

## REPAIRING DRIVE CHAINS

When necessary to repair a chain, remove damaged link or links by pushing out pins with chain repair tool. Then install necessary repair links, noting that spring clips are properly and securely locked on pin ends.

Front chain is a double row or duplex chain; rear chain is a single row chain. The chain tool furnished in the tool kit is designed to accommodate both.

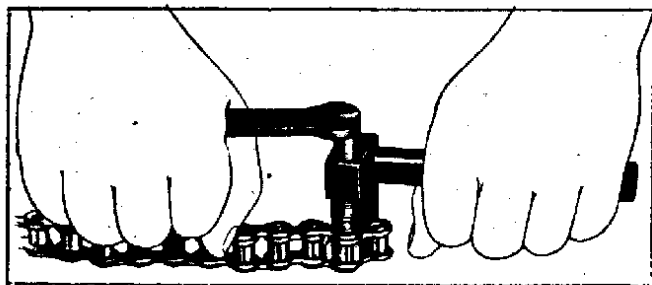

ILLUS. 5  
USE OF CHAIN REPAIR TOOL

## Lubricating Rear Chain

### *Applying to rear chain not lubricated with rear chain oiler:*

Under dry, hard surface road operation, apply engine oil at 750-mile intervals. Under dusty, wet or muddy conditions, oil chain daily with a very light oil.

Occasionally chain should have additional lubrication as follows:

Remove chain from motorcycle. Soak and wash thoroughly in a pan of kerosene. After removing chain from kerosene, hang it up for a time to allow kerosene to drain off.

Immerse for a short time in a pan of grease heated to consistence of light engine oil. If grease and facilities for heating are not at hand, substitute light engine oil. While immersed, move chain around to be sure that hot grease or oil works through all inside parts.

After removing from hot grease or oil, allow chain to drain and wipe all surplus grease or oil from surface of chain.

Install chain on motorcycle. Inspect connecting link and spring clip closely for bad condition. Replace if at all questionable. Be sure spring clip is properly and securely locked on pin ends.

### *Applying to rear chain lubricated with rear chain oiler:*

A few motorcycles are equipped with rear chain oiler that automatically lubricates chain. Instructions applying to front chain lubrication, also apply to rear chain except that standard factory setting of rear chain oiler adjusting screw is 1/2 turn open.

Occasionally chain should have additional lubrication as explained above for chain not automatically lubricated.

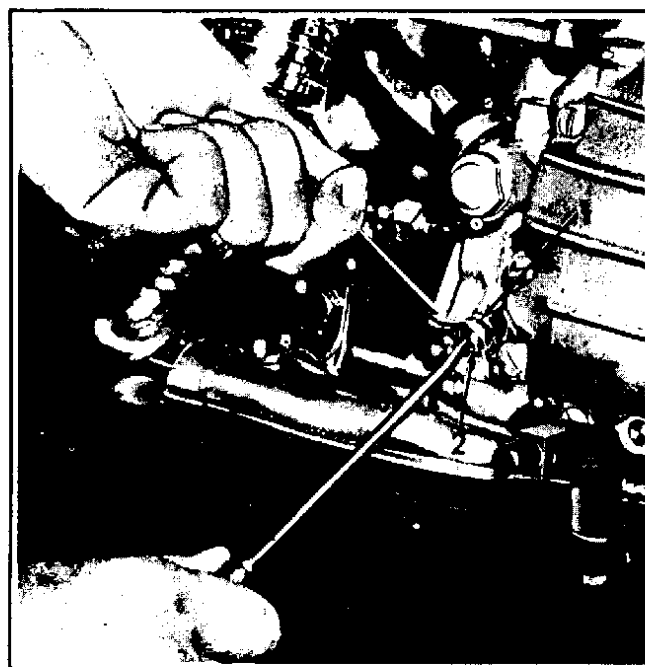

ILLUS. 3 Adjusting Front Chain Oiler

## CLUTCH AND GEAR SHIFTER

Need for attention to clutch and control is indicated by clutch slipping under load or dragging in released position. In either case, the first thing to be checked is adjustment of control; this is the attention usually needed.

The first warning or indication of shifter control being out of correct adjustment is transmission "jumping" out of engagement when accelerating under heavy pull. This warning must not be disregarded.

### Checking and Adjusting External Gear Shifter Control

1. See that control joints from transmission gear shifter lever to gear shifter handle are well oiled and free-working.
2. Check handlever center pivot bolt nut for tightness.
3. Observe whether there is binding or interference with shifter rod at any point in the shifting range; this is sometimes found as a result of bent rod.

4. Check to determine whether or not shifter rod is correctly adjusted so that when handlever is moved to any gear position in shifter guide, transmission lever moves to just the right position to fully engage shifter clutch and shifter cam spring plunger (inside transmission).
5. Adjust as follows: Locate handlever in shifter guide "neutral" position, disconnect shifter rod from handlever and, with slight backward and forward movement, carefully "feel" transmission lever into exact position where shifter cam spring plunger (inside transmission) seats fully in retaining notch. Next, see that handlever is in exact "neutral" position in the guide and adjust length of shifter rod so shifter rod end hole lines up with hole in handlever. Insert bolt and tighten nut. It is advisable to repeat this check in "low" and "second" gears to be sure of having best all-around adjustment.

After each adjustment of front chain, also whenever any irregularity is noticed with shifting and positive engagement in different gear positions, adjustment of this rod must be checked.

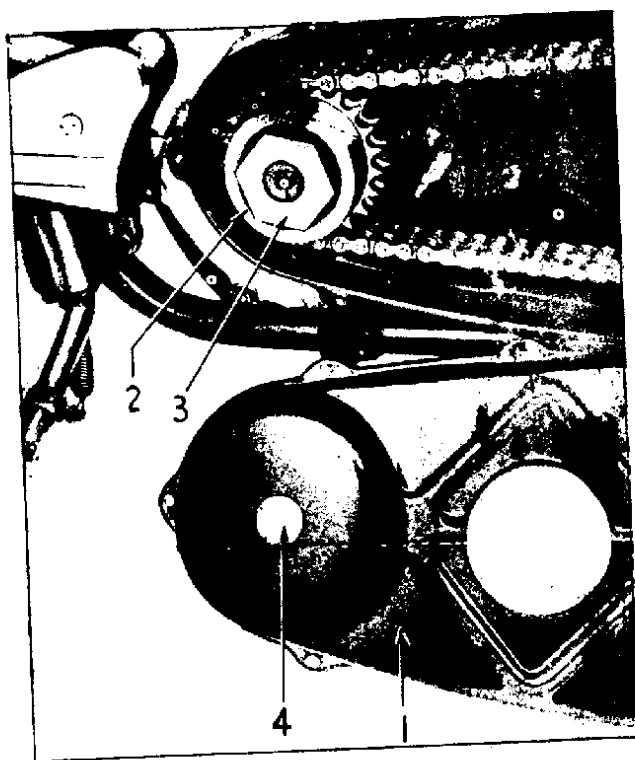

1948-1964

### ENGINE SPROCKET REMOVAL

Remove engine sprocket nut (right thread) using Harley-Davidson special wrench, Part No. 12645-26. It will be necessary to strike wrench handle with a hammer to loosen nut. Free sprocket from shaft taper by striking flat surface, near outer edge, a light but sharp rap with a hammer being careful not to strike sprocket teeth or sprocket shaft threads. Sprocket and chain are then free to be removed.

## EARLY STYLE

### MOUNTING COMPENSATING SPROCKET

1938 to, and including, 1954 Big Twin Models  
22 Tooth Part #40280-54 — 23 Tooth Part #40282-54

Remove chain guard (1), engine sprocket and sprocket shaft key from motorcycle.

Install longer key supplied with kit. Assemble compensating sprocket (2) on engine. Be sure that "O" ring oil seal is in place on compensating sprocket nut (3) before nut is placed and tightened in position.

Cut a hole in the center of the front chain guard (1) front bulge in the following manner:

1. Either by using a divider or by placing a 4 1/2" circle on the inside of the chain guard front bulge as a template determine the exact center of this bulge. Center punch and drill a 1/8" hole.
2. Using a 7/8" hole saw cut a hole in the center of the chain guard front bulge and insert chrome plated snap cap (4) in place as indicated in figure above.

**NOTE** There are hole saws made by numerous manufacturers and should be available locally to dealers. One of these hole saws is manufactured by Black and Decker and their part numbers follow:

Part	Part No.
Saw	16883
Mandrel	22181

The compensating sprocket should be greased with Harley-Davidson All Purpose Grease before placing motorcycle in service. Thereafter grease at 1500 mile intervals or oftener as required.

# CHASSIS

## WHEELS

### GENERAL

Good handling of a motorcycle at any speed will result in maximum tire mileage. Tires must be transposed at regular intervals for best performance and long life.

The larger the tire size and higher the average road speed, the more essential it is that wheels and tires be given proper attention. A tire kept in continuous solo motorcycle front end service long enough to allow tread to wear irregular and peaked, may cause high speed weave, especially if over-inflated.

At regular intervals of approximately 5000 miles or when a solo motorcycle develops handling irregularities at high speed, check the following list for possible causes:

1. Loose wheel axle nuts.
2. Excessive wheel hub bearing play.
3. Loosened spokes.
4. Rear wheel out of alignment with frame and front wheel.
5. Rims and tires out-of-true sideways (tire run-out should not be more than 3/64 in.).
6. Rims and tires out-of-round or eccentric with hub (tire run-out should not be more than 3/32 in.).
7. Irregular or peaked front tire tread wear. Determine mileage since tires were last transposed. If mileage is found to be 2500 or more, transpose front and rear wheels and tires even though irregular wear or peaking of front tread is not noticeable.
8. Tires over-inflated. Check "Tire Data," Section 1A. Do not over-inflate.
9. Tire and wheel unbalanced. Static balancing will be satisfactory if dynamic balancing facilities are not at hand.
10. Steering head bearings loose. Correct adjustment and replace pitted or worn ball bearings and races.
11. Shock absorber not functioning normally. Check possible causes see "Forks "

Switching wheels and tires approximately every 5000 miles and inflating to recommended pressure are of major importance. In many cases, this attention alone applied to a solo motorcycle will remedy faulty handling at higher speeds.

It is advisable to rebalance wheels and tires, at least statically, whenever casing and/or tube is replaced.

### SERVICING WHEELS

Front and rear wheels may be removed as necessary for wheel or tire service. When removing a wheel, apply brake to hold drum securely while pulling wheel from drum. When detached from drums, Glide wheels are interchangeable.

### MEMORANDA

#### REMOVING FRONT WHEEL (Fig. 2C-1)

Block motorcycle under frame until front wheel is clear of ground. Disassemble in following order:

Remove the cotter pin (1), axle nut (2) and flat washer (3). Servi-Car wheel disassembly includes removing bushings (4); also remove the five wheel mounting socket screws (5), loosen the two right slider cap nuts (7) and remove axle (6). Remove front wheel, leaving the brake drum in its place over the brake shoes.

When replacing the wheel, assemble in reverse order. First securely tighten wheel mounting socket screws (5) and axle nut (2), and then tighten the two right slider cap nuts (7). This will insure correct alignment of fork sides.

#### REMOVING REAR WHEEL GLIDE

Elevate motorcycle rear wheel with Service Stand, or suitable blocking under frame. Remove two rear screws from fender support, and raise end of fender as shown in Fig. 2C-2. Remove the five socket screws (4) that secure wheel to brake drum. The socket screw wrench can be inserted only at the rear of axle; turn wheel to bring each screw to this position.

Remove axle nut (3) and axle nut lock washer (2). Remove axle (1) from brake drum side of motorcycle and then remove spacer (5) from between wheel hub and right axle clip. Apply rear brake and remove wheel.

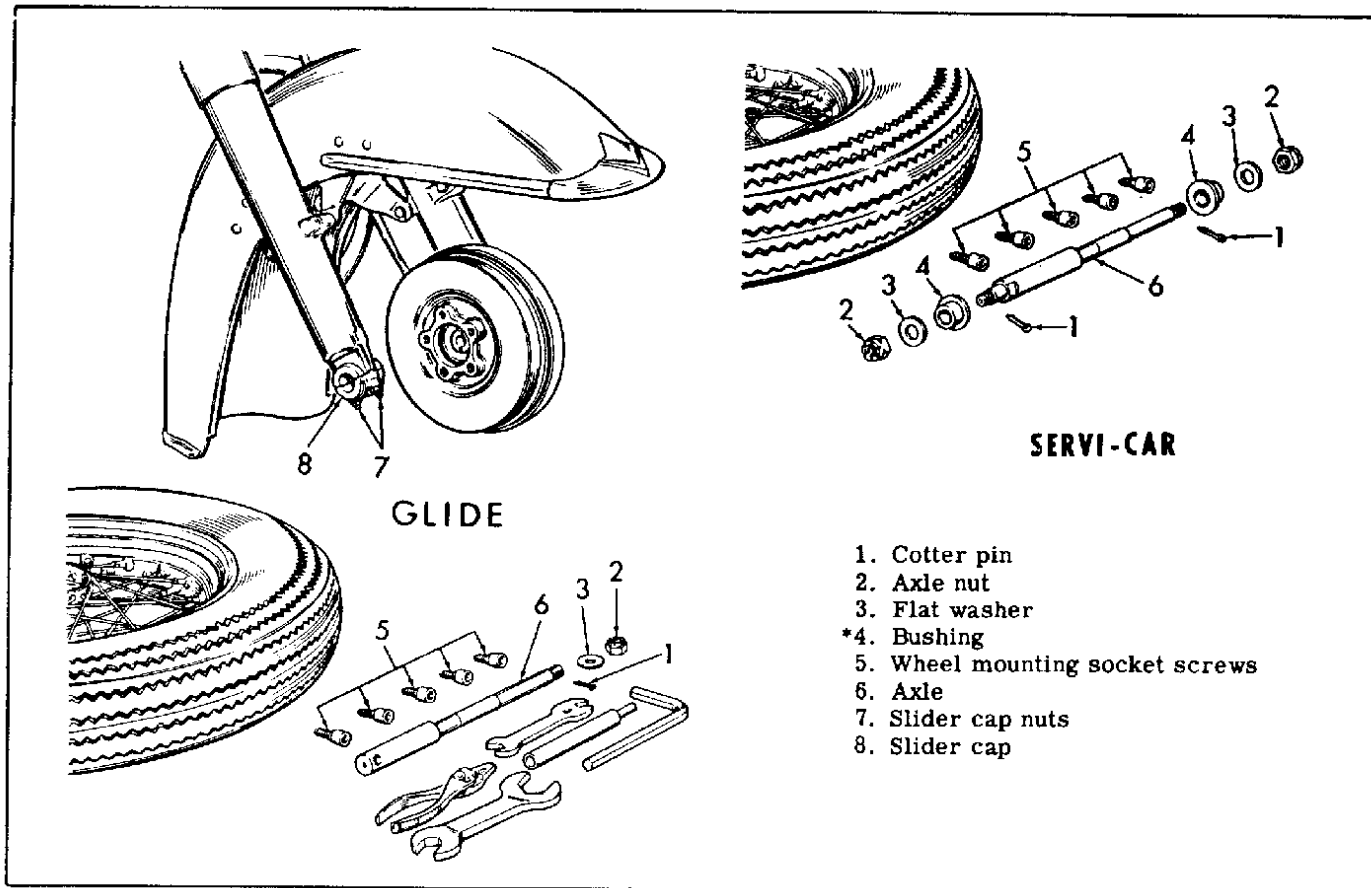

Figure 2C-1. Removing Front Wheel

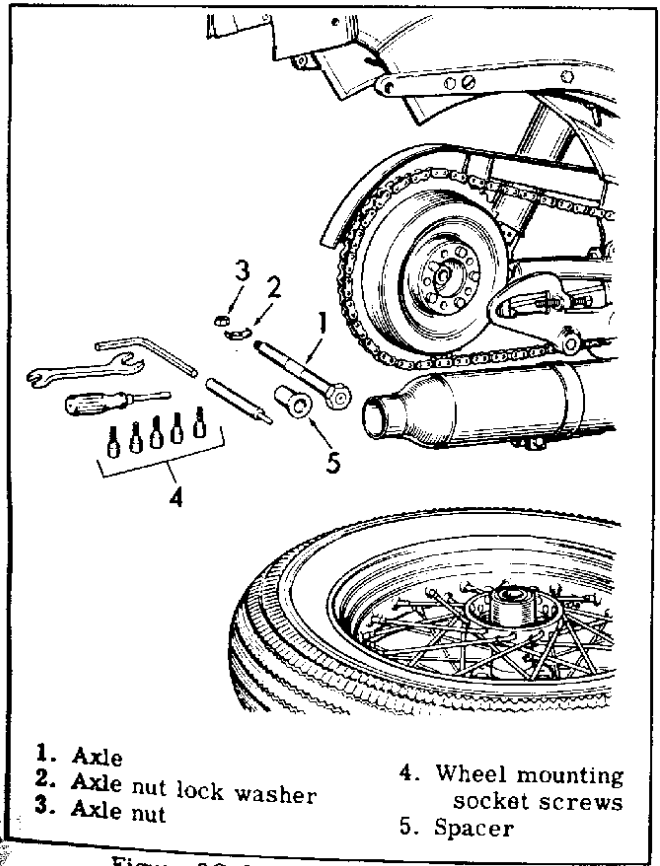

Figure 2C-2. Removing Rear Wheel

When installing wheel, reverse the removal procedure. Securely tighten the five wheel socket screws before tightening the axle nut (3). To avoid possibility of wheel working loose and damaging clamping flange, it is important that socket screws be pulled very tight.

**REMOVING SIDECAR WHEEL.**

Raise wheel by blocking up under sidecar chassis. Loosen nut that secures fender front bracket to sidecar step lug. Loosen the fender inner brace clip bracket nut. Remove outside axle nut, lock washer and outer brace. Hinge fender forward, taking care to provide slack for taillamp wiring. Remove extension nut, axle nut and washer. Pull wheel from axle with brake drum attached.

Detachment of wheel from brake drum is necessary only when wheel or brake drum is to be replaced or wheel interchanged. To detach wheel from brake drum, remove the five wheel mounting socket screws that secure wheel to brake drum.

To replace wheel, reverse removal procedure. Tighten wheel mounting socket screws securely to

avoid possibility of wheel working loose and damaging hub flange.

**SERVICING WHEEL HUBS (Fig. 2C-3)**

All spoked wheel hubs are identical. However, keep parts for all wheels separated. Bearing assemblies (20, 21 and 11, 12) and thrust bearing adjusting shims (7) have been fitted at the factory, and subsequent hub repairs may have included installing oversize bearings. A transposition of parts will result in oversize or undersize fit.

**DISASSEMBLING WHEEL HUB (Fig. 2C-3)**

Remove five thrust bearing cover screws (1) and lock washers (2). Lift off thrust bearing outer cover (3), cork grease retainer (4), thrust bearing housing (5), gasket (6), a number of adjusting shims (7) which varies with the hub, thrust washer (8), thrust bearing sleeve (9) and another thrust washer (10).

Remove bearing rollers (11) and retainer (12), and roller retainer thrust washer (13).

Turn hub over and remove spring lock ring (14), retaining washer (15), hub inner sleeve (16), cork grease retainer (17), spring lock ring (18) and roller bearing washer (19).

Large diameter retainer (21) and bearing rollers (20) are then free to be removed from hub shell (22).

**INSPECTION AND REPAIR (Fig. 2C-3)**

Clean and dry all parts and inspect for wear. If excessive sideplay is present, one or more bearing adjusting shims (7) must be added. Thrust bearing sleeve (9) must be free with thrust bearing outer cover (3) completely screwed down. A clearance of .005 in. to .007 in. is correct. Leave cork grease retainer (4) out of thrust assembly while determining correct adjustment of thrust sleeve, and reinstall it when adjustment is completed.

Excessive radial (up and down) play in wheel hub bearings can be taken up by fitting oversize rollers (11 and 20). Bearing rollers are available from .001 in. undersize to .001 in. oversize in steps of .0002 in. Select roller size that will give .001 in. to .0015 in. clearance.

**ASSEMBLING WHEEL HUB (Fig. 2C-3)**

Assemble hub components in reverse order of disassembly. Closed sides of roller bearing retainers (12 and 21) go toward center of hub. Be sure to include a plain washer (25) under grease fitting (24) in thrust bearing housing (5). Failure to do so will cause end of fitting to crimp adjusting shims (7).

Apply a thin coating of "Grease-All" grease to rollers, races and thrust washers. After final assembly, inject 1 ounce additional grease into hub. Carefully check hub to avoid a bearing fit too tight. Roller bearings must turn freely and have slight play. Do not over-lubricate hub. An over-lubricated hub will throw grease that may get into brake assembly.

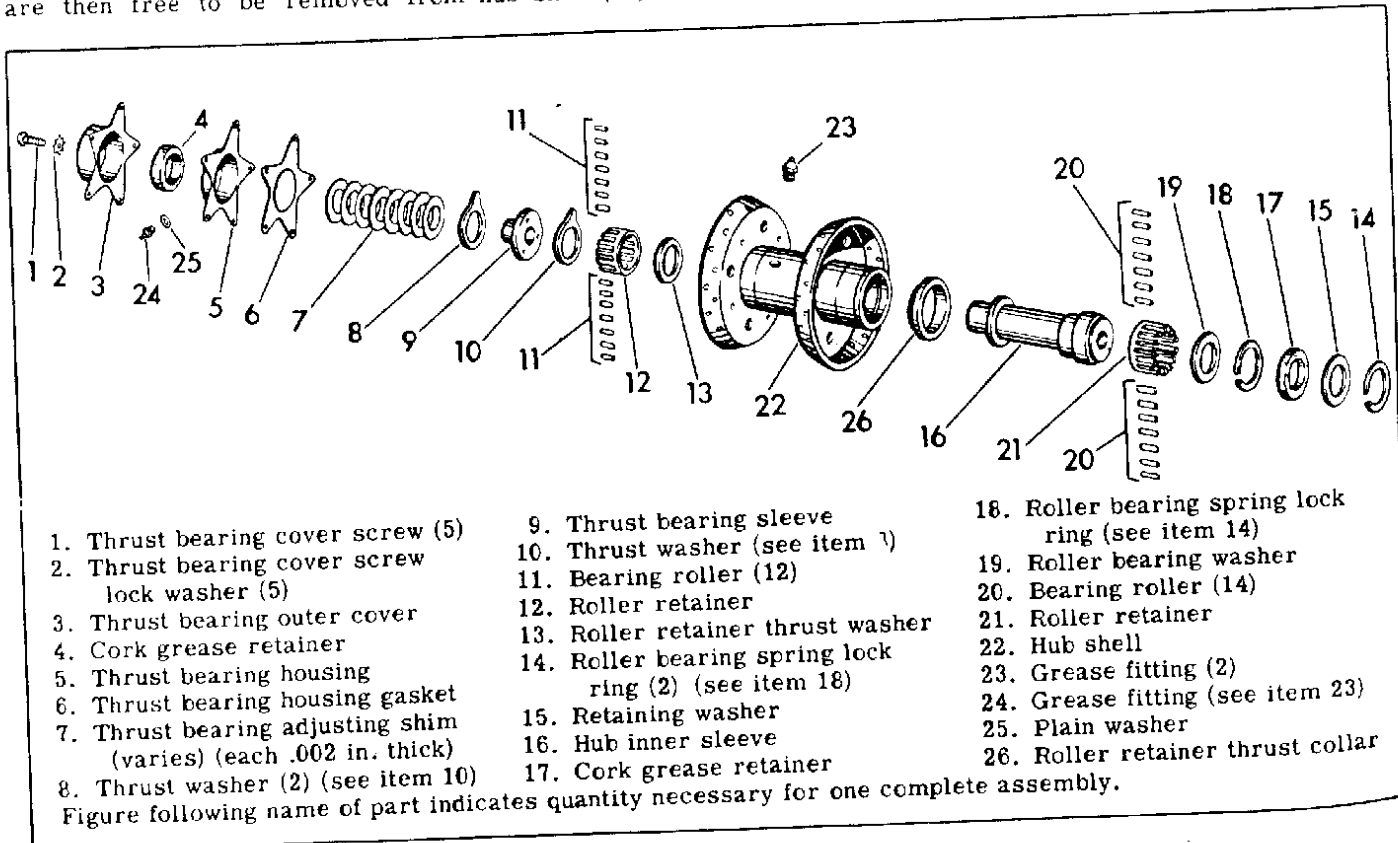

Figure 2C-3. Wheel Hub - Exploded View

## REPLACING REAR WHEEL SPROCKET

To replace a worn rear wheel sprocket remove wheel from motorcycle as described in "Removing and Installing Rear Wheel." Disassemble brake drum from wheel. Chisel heads off all rivets and dowel pins from brake shell side and punch them out. If the rivet holes are not worn, use the rivet holes again. If the rivet holes are found slightly worn or elongated and drum is in good condition, drill a new set of rivet holes in drum flange midway between original dowel and rivet holes.

To drill new rivet holes, proceed as follows using new sprocket as a template for locating holes.

1. Drill a hole from the brake shell side.

Size:  $5/32$  in. dia. drill  
 $1935$  in. dia. (No. 10  
 drill) for  $3/16$ " rivet

2. Drill one hole and insert rivet (do not head rivet).
3. Drill a hole directly opposite first hole and insert rivet (do not head rivet).
4. Drill remaining 14 rivet holes.
5. Remove rivets and separate sprocket from drum.
6. Remove burrs from newly drilled holes.

Whenever a rear wheel sprocket is replaced it is very important to drill new dowel holes to insure a press fit for the dowel pins. Use the new sprocket as a template and drill the four dowel pin holes  $3/16$  in. dia. for a press fit.

Position sprocket and drum on center support flange of Riveting Jig, Part No. 95600-33B. Proceed as follows, inserting and seating dowel pins first, and then rivets.

1. Insert dowel pins and rivets from brake shell side.
2. Use hollow driver and seat dowel pins and rivets at the same time driving sprocket and hub flange together.

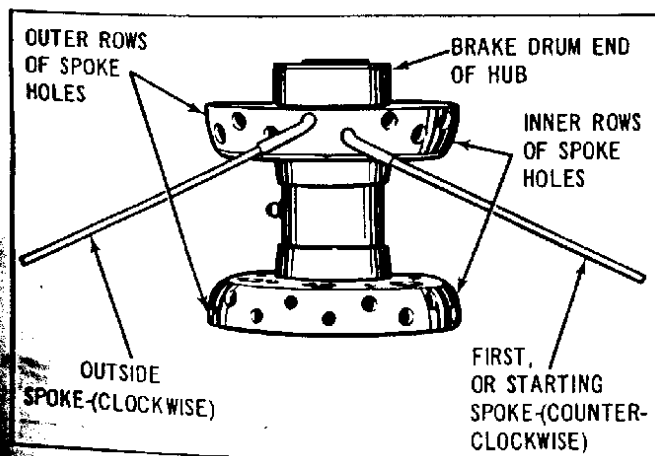

Figure 2C-4. Starting Spokes in Wheel Hub

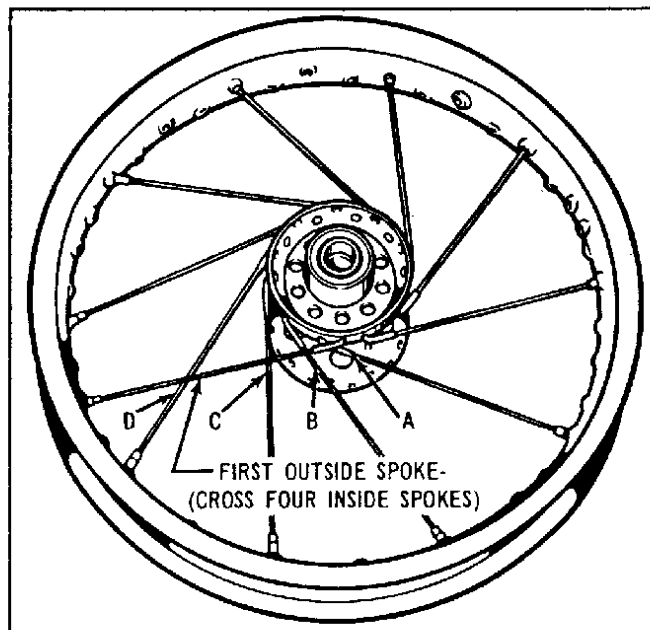

Figure 2C-5. Spoking Wheel

3. Use punch to flare dowel pin ends and rivet ends until heads extend  $3/64$  in. above sprocket face for  $5/32$  in. rivet size and  $3/32$  in. for  $3/16$  in. rivet size. Use concave end punch for small diameter rivets and dowel pins. Use flat end punch for larger diameter rivets.

4. Rivet opposite dowel pins and rivets until all are in place.

### SPOKING WHEELS

Front, rear and sidecar wheels are spoked identically. Spoke holes in hub flanges are in two rows around flange, ten inner row holes and ten outer row holes in each flange.

All spokes must be inserted from inside of flange.

1. Place hub on bench with brake drum end of hub up.
2. Insert spokes in ten inner spoke holes of brake side flange (see Fig. 2C-4).
3. Swing loose end of spokes counterclockwise as far as hub will allow without turning hub.
4. Place rim over hub (with tire valve hole 90 degrees to 180 degrees from hub grease fitting) and insert spokes in upper row of holes in rim that angle in same direction as spokes.

### NOTE

18 in. rim is placed over hub, either side down; 16 in. rim is placed over hub with tire valve hole down (opposite brake drum side of hub).

Just start nipples on spokes as they are inserted in rim.

5. Insert spokes in outer ten holes of flange and swing spokes clockwise (see Fig. 2C-5).



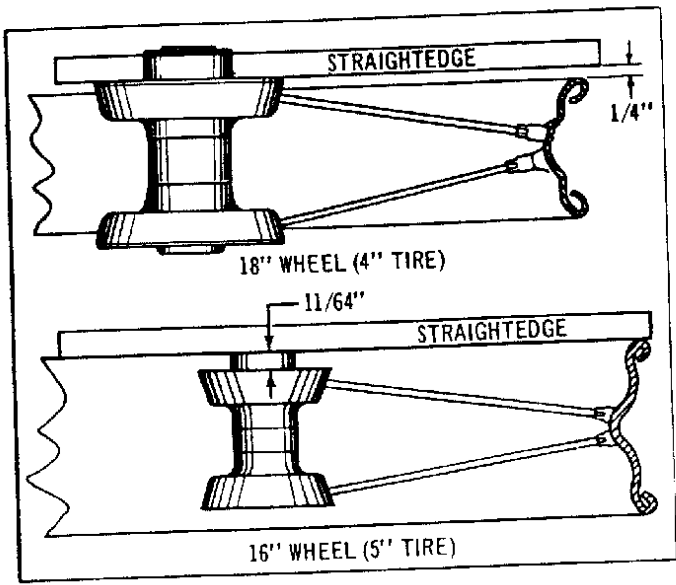

Figure 2C-6. Centering Wheel Rim

6. Select any outer spoke, cross it over four inner spokes (A, B, C and D) and insert spoke in nearest upper rim hole and start nipple. Follow same procedure with balance of spokes.

7. Turn rim and hub over. Repeat operations 2, 3, 5 and 6, except in operation 3 swing spokes clockwise and in operation 5 swing spokes counterclockwise.

**NOTE**

Outer spokes on both sides point in same direction.

**TRUING WHEEL**

1. Install truing arbor in wheel hub and place wheel in Wheel Truing Stand, Part No. 95500-29. Secure arbor nuts so that hub will turn on its bearings.

2. Turn each nipple on just far enough to cover spoke threads.

3. Start at valve hole and tighten all nipples three full turns each, using special Nipple Wrench, Part No. 94681-39. If further tightening is needed to pull spokes snug, tighten all nipples one full turn at a time until spokes are snug.

4. Check rim for centering sideways with hub, for running true sideways and concentricity. Centering rim sideways with hub and truing rim sideways must be done as one operation.

Rim must be properly centered sideways in relation to hub for correct alignment and "tracking" of front and rear wheels. Fig. 2C-6 shows method of using a straightedge to determine correct sideways centering of wheel rims. Straightedge should be a perfectly straight metal bar. To adjust sideways centering, loosen all nipples on one side and tighten all nipples on opposite side same amount.

For 16 in. wheel (5.00 in. tire), place straightedge across rim on brake side and measure the distance

from straightedge to brake side spoke flange of hub. When rim is correctly centered, this distance will be 11/64 in.

For 18 in. wheel (4.00 in. tire), lay straightedge across brake side spoke flange of hub and measure distance from straightedge to rim. When rim is correctly centered, this distance will be 1/4 in.

Adjust truing stand gauge to side of rim as shown in Fig. 2C-7 so rim at highest point will strike gauge as wheel is rotated slowly. Loosen nipples at highest point of rim on gauge side and tighten nipples on opposite side the same amount. Repeat this operation until rim runs true sideways. Reverse loosening and tightening of nipples as explained above if rim moves too far away from gauge. After each loosening and tightening of spokes, check rim in relation to hub as explained in above paragraphs. Rim should be trued to within 1/32 in. sideways run-out.

After rim has been centered sideways with wheel hub and runs true sideways, check it for concentricity. Adjust truing stand gauge to circumference of rim as shown in Fig. 2C-8. If rim runs eccentric (out of round), nipples must be loosened at points rim does not contact gauge, and nipples tightened at points rim contacts gauge. Amount nipples are to be loosened or tightened is determined by the amount rim runs eccentric. Rim should be trued to within 1/32 in. concentricity.

5. After above operations have been checked and corrected, start at valve hole and tighten nipples one turn at a time all the way around rim until spokes are normally tight. While tightening nipples, repeatedly check rim with gauge according to instructions in step 4.

After all nipples have been pulled up until spokes are normally tight and wheel is true, or nearly so, seat

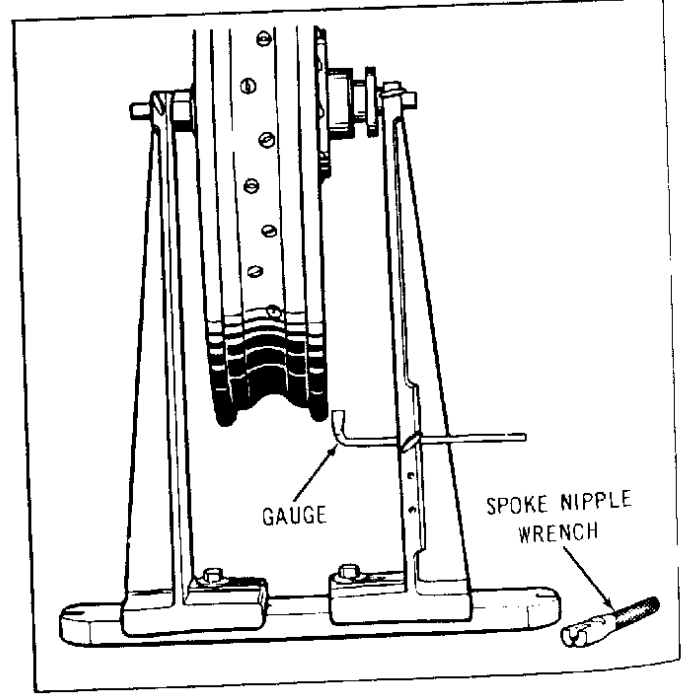

Figure 2C-7. Truing Rim Sideways

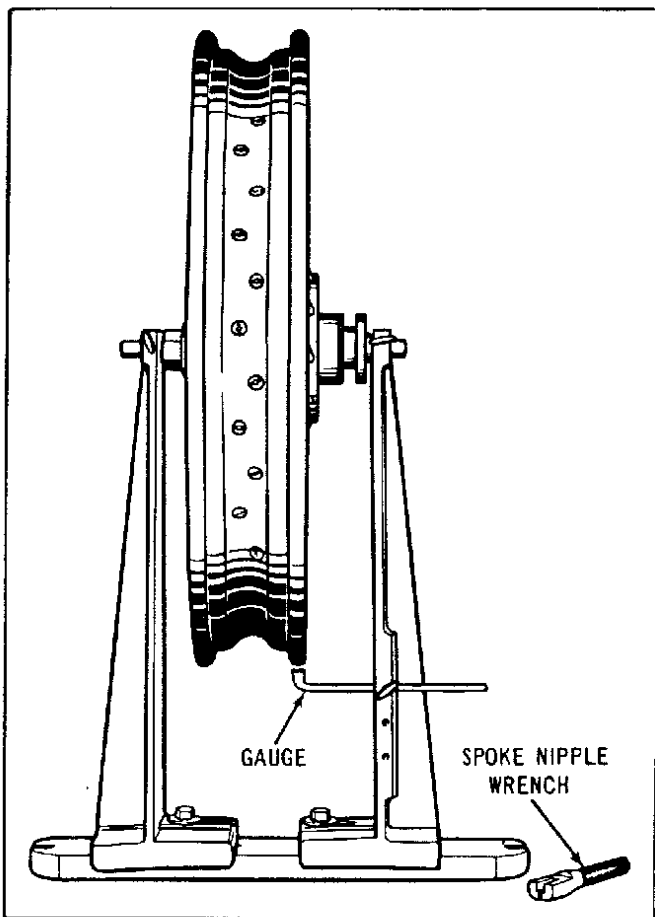

Figure 2C-8. Truing Rim Concentric with Hub

each spoke head into hub flange with a sharp blow, using a flat nose punch and hammer. Then retighten all nipples and finish truing wheel. This method allows spokes to be drawn tighter at the start and prevents possibility of spokes loosening, due to spoke heads seating into flange, after wheel is put into service.

**CAUTION**

Do not tighten spokes too tight or nipples may draw through rim, or hub flanges may be distorted. If spokes are left too loose, they will continue to loosen when wheel is put in service.

6. File or grind off ends of spokes protruding through nipples to prevent puncturing tube when tire is mounted.

**REMOVING AND INSTALLING TIRES**

Wheel rims are of the drop-center type, having a depression or "well" in center of rim. Rim-well, being smaller in circumference than rest of rim, allows one casing bead to fit loosely in it while other bead is being worked over edge of rim.

**REMOVING TIRE FROM RIM**

Remove wheel; lay wheel on its side.

Remove valve cap and valve core to free all air from tube. Remove valve stem nut (18 in. rim).

Loosen both beads from rim flanges by stepping on sides of tire or by using a tire tool. Stand or kneel on tire opposite valve to push bead into rim-well.

Using tire tools (not sharp instruments), start upper bead over edge of rim at valve. Don't use force when starting bead over edge of rim with tire iron, because bead wires may be broken or stretched and tire ruined. Carefully remove tube before attempting to remove second bead.

Push lower bead into rim-well on one side and insert tire iron on opposite side and pry bead over flange. After a portion of second bead is started over rim edge, tire can be further removed from rim without aid of tire iron.

It is not always necessary to completely remove casing from rim. Removing one side allows tube to be removed and reinstalled and also allows inside of casing to be inspected.

**MOUNTING TIRE ON RIM**

Before installing tube in tire, all dust and dirt, particularly hard particles which might chafe an inflated tube, must be removed. Wipe tube and inside of tire thoroughly with clean, dry cloth. If rim is dirty or rusty, clean with a stiff wire brush. Be sure to examine a used tire carefully for fabric injuries that may damage tube.

Before mounting tire, see that rubber rim strip is in place in rim-well, and that rim strip valve hole registers with valve hole in rim.

Tire balance mark on Firestone tires is a red triangle and on Goodyear tires a red dot.

Insert tube in tire, (placing valve at tire balance mark). Swab thoroughly all around base of tube, between the tube and side walls of tire with a heavy suds solution of tire mounting compound and water. Bead seat of tire should not be coated. Inflate tube just enough to round it out. With wheel lying flat, place tire on rim and align valve with hole in rim.

Push bottom bead into rim-well near valve and hold in well while forcing remaining portion of bead over rim flange with a tire tool.

Spread tire and insert valve through hole in rim.

Force upper bead over rim flange and into well at point opposite valve. Stand or kneel on this side of tire to hold it in well and pry remaining portion of tire over rim flange. While forcing bead over rim flange, keep as much bead as possible in rim-well. Be careful not to damage beads or pinch tube. Inflate tire to recommended pressure and check valve for leak. See tire inflation pressures in "Tire Data," Section 1A.

After inflating to recommended pressure, completely deflate to smooth out any wrinkles in tube and allow tube to find its place, free from strain or stress. Again inflate to recommended pressure and check valve for leak.

# SHOP DATA:

When a racing motorcycle or car is being groomed for an event on road or track, just as close attention is given to perfect condition of wheels and tires as to engine tuning for maximum performance. Wheel bearings are checked, wheels and tires are checked for out-of-true sideways, eccentricity, out-of-round, and out-of-balance. Careful attention is given to anything found not just right. If a tire tread is found worn irregular to an appreciable degree, tires are transposed or a new tire installed. Inflation pressure is carefully adjusted to the poundage known to be right for weight of vehicle and nature of event.

In other words, engine R.P.M. and horsepower don't mean anything unless the vehicle being driven can be guided with ease and safety at top speed. If, due to faulty wheel and tire condition, a racing vehicle develops wheel hop, shimmy, or some other bad handling condition which makes control difficult at high speed, it might just about as well be without an engine.

Stock model motorcycles of today are approaching the speed of racing model motorcycles. Therefore, due attention to wheels and tires of stock motorcycles driven solo at high speed is just as essential as in the case of a racing motorcycle. Too many motorcycle mechanics are pretty much engine and horsepower minded, and as a result are inclined to consider wheels and tires something secondary to be given attention only after something fails, or a rider complains of serious handling irregularities at high speed.

Riders as a general thing do their own tire inflating and a wide variable is found in the pressures to which they inflate. This probably is mainly because no one has taken the time to impress them with the importance of correct inflation pressures according to load and tire size, and to enlighten them as to the influence this has on good or bad high speed handling. One motorcycle will be found with 10 lbs. tire pressure; another with 25 lbs. or more.

Here and there a rider transposes his tires to avoid excessive irregular wear of front tire tread and to equalize tire wear, but most riders don't make this a practice because they don't realize it is a must, if high speed handling is to be kept at its best. A tire kept in continuous front end service long enough to allow tread to wear quite noticeably irregular and peaked, is very likely to handle poorly at high speeds especially if over-inflated.

When a rider complains of bad handling at higher speeds, check as follows and give attention as needed:

CHECK FOR -

- 1 - Loose wheel axle nuts.
- 2 - Excessive wheel hub bearing play.
- 3 - Loosened spokes.
- 4 - Rear wheel alignment in frame and with front wheel.
- 5 - Rims and tires too much out-of-true sideways. (Should not be more than 3/64").

- 6 - Rims and tires too much out-of-round or eccentric with hub (Should not be more than  $3/32$ " ).
- 7 - IRREGULAR OR PEAKED FRONT TIRE TREAD WEAR; ALSO DETERMINE MILEAGE SINCE TIRES WERE LAST TRANSPOSED. IF MILEAGE IS FOUND TO BE 2500 OR MORE, TRANSPOSE TIRES EVEN THOUGH IRREGULAR WEAR OR PEAKING OF FRONT TREAD IS NOT VERY NOTICEABLE.
- 8 - Tire inflation as per inflation pressure chart below. DO NOT OVER-INFLATE.
- 9 - Tire and wheel balance, if balancing equipment is available. Static balancing will be satisfactory, if dynamic balancing facilities are not at hand.
- 10 - Correct adjustment of steering head bearings and any indication of pitted ball races.
- 11 - Normal functioning of hydraulic forks.
- 12 - Good working order and adjustment of steering damper so that it can be applied easily and gradually to any desired steering friction.

With attention given as outlined you will in nearly every case find any high speed handling faults corrected. The possible exception will be the case where there is serious frame or fork misalignment or maybe a tire in extremely bad condition, which should be replaced. REMEMBER, TRANSPOSING TIRES AND INFLATING NO HIGHER THAN THE RECOMMENDED PRESSURE ARE OF FIRST IMPORTANCE. IN MANY CASES YOU WILL FIND THAT THIS ATTENTION ALONE APPLIED TO A MOTORCYCLE THAT DEVELOPS FAULTY HANDLING AT HIGHER SPEEDS, WILL GAIN THE DESIRED RESULT.

#### TIRE INFLATION PRESSURES

OHV MODEL  
Solo-Rider Only  
4.00" Tire - Front 14 lbs; Rear 16 lbs.  
5.00" Tire - Front 12 lbs; Rear 14 lbs.

The above tire inflation pressures are based on rider weight of approximately 150 lbs.

When above weights are exceeded by 50 lbs. or more, increase tire pressures as follows:  
For each 50 lbs. of overload, increase pressure of rear tire, 2 lbs; front tire 1 lb.

# EARLY MODEL SERVICING HANDLEBAR CONTROLS

(To Identify Items, Refer to Illus. 19)

To lubricate control parts, or to replace a throttle or spark control wire, or a damaged control wire housing, proceed as follows:

Disconnect control wire at carburetor or circuit breaker. Insert a large heavy screw driver through hole in end of grip as shown in Illus. 18 and turn out end screw (A) by using a wrench on screwdriver. Sometimes this screw is difficult to remove. In this case, insert a punch in slot in screw and strike it two or three sharp blows to start it. After removing grip sleeve assembly (C), working parts are accessible. Remove roller (E), roller block (F), and roller pin (D). Plunger (G), with control wire (H) attached, can now be pulled out of handlebar end. If wire is broken, remove other half from housing at connection end. Wire is fastened into end of plunger by means of a hexagon head screw (I) with a hole through it.

Remove any rust, dirt or gum from grip spiral, handlebar end, wire plunger, and inside of handlebar where plunger operates.

If control wire housing is to be removed, first remove grip control parts as explained above. Then, remove the small lock screw underneath handlebar, just ahead of spiral locating shoulder on bar (on left bar, this screw is under headlamp dimmer switch). After lock screw is removed and housing freed from housing clamp or clamps, it can be pushed out through end of handlebar.

When installing control wire housing, see that housing end is secured in handlebar with lock screw (screw must register in groove in control coil plug) and that housing is secured with clamp or clamps.

When reassembling control parts to handlebars, apply a light coat of grease or a few drops of engine oil to control wire as it is inserted into control housing, and lubricate remaining parts with grease (see "Lubrication Chart." Overgreasing of these parts will cause a messy condition.

End screw (A) can best be started, without danger of crossing threads, by holding grip sleeve assembly

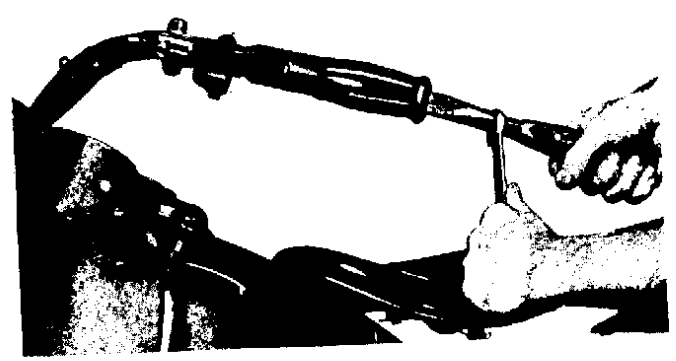

ILLUS. 18  
REMOVING HANDLEBAR GRIP SLEEVE ASSEMBLY

(C) back with slight pressure against screw while starting screw in handlebar end. This squares screw with end of grip sleeve, aligning threads. Always tighten screw securely.

After throttle and/or spark controls are completely assembled, connect control wire at carburetor and/or circuit breaker.

Adjust throttle control so throttle closes and opens fully with throttle control grip movement. There should be about 1" to 1 1/2" between end of throttle control wire housing and throttle lever when lever is in fully closed (forward) position.

With circuit breaker in fully advanced position, be sure end of spark control wire points directly to hole (in which it is to be secured) in advance and retard lever—  
or timing adjusting stud—

O.H.V. Models: Allow about 1/2" of spark control wire housing to extend beyond clamp. Side Valve Models: allow about 2" of spark control wire housing to extend beyond clamp.

All Models: Adjust spark control wire so circuit breaker advances and retards fully with spark control grip movement.

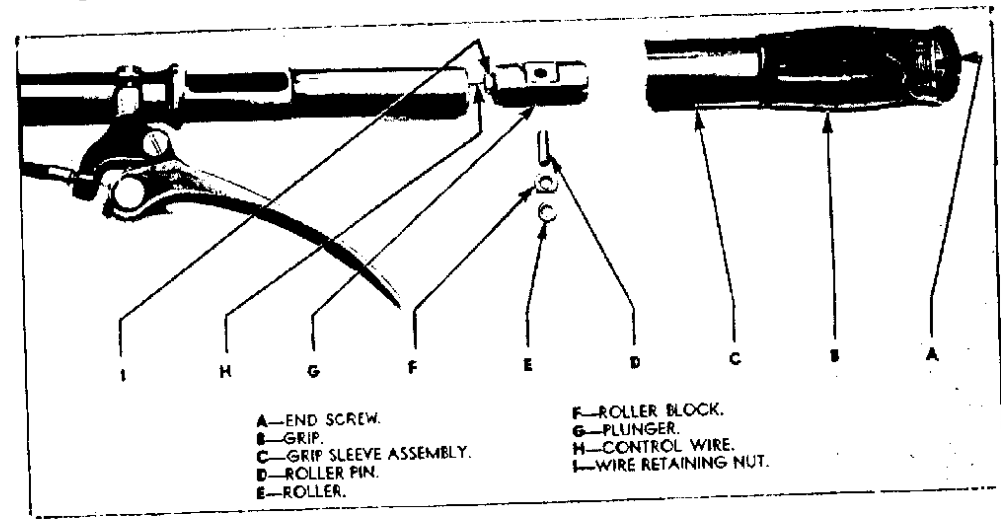

ILLUS. 19  
CONTROL GRIP DISASSEMBLED

## REPLACING FRONT BRAKE CONTROL CABLE

Remove control cable lower clevis clamp nut and pull cable out of clevis. Next, remove cotter pin and flat washer from handlebar hollow pin and pull pin out of lever. Control cable can now be pulled out of housing.

Insert new control cable in housing (at handlebar end). Make sure lower end of cable is inserted through adjusting sleeve. Apply grease or engine oil to new cable as it is being inserted. Handlebar hollow pin must be reassembled before lower end of cable is connected. Narrow slot in pin straddles cable. Replace flat washer and cotter pin at end of hollow pin.

Pull cable taut making sure control cable housing is seated in recess in handlebar bracket and in adjusting sleeve and that handlebar is tight against its bracket. With cable pulled taut, insert it through cable clamp nut, through clevis and back through nut and adjust cable so there will be 1/4" of cable between end of adjusting sleeve and end of clevis. Holding cable in this position, install cable clamp nut on clevis and tighten nut securely. Cut off excess wire.

Adjust control, by means of adjusting sleeve, so that handlebar moves freely about one-quarter of its full range of movement before brake begins to take effect. Tighten adjusting sleeve lock nut.

## HANDLEBAR (LATE MODEL)

### SERVICING HANDLEBAR CONTROLS

#### NOTE

Spark control information applies to earlier models having manual spark advance.

Handlebar controls for throttle and spark advance must operate freely. If a control becomes stiff and hard to adjust, parts must be removed and cleaned of caked grease, gum and dirt. A kinked control coil must be replaced if complete straightening cannot be accomplished.

DISASSEMBLING HANDLEBAR CONTROLS (Fig. 2D-2)

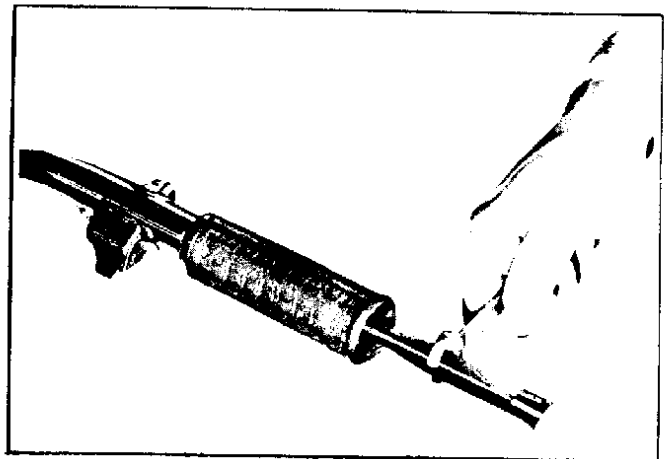

Figure 2D-1. Removing Handlebar Controls

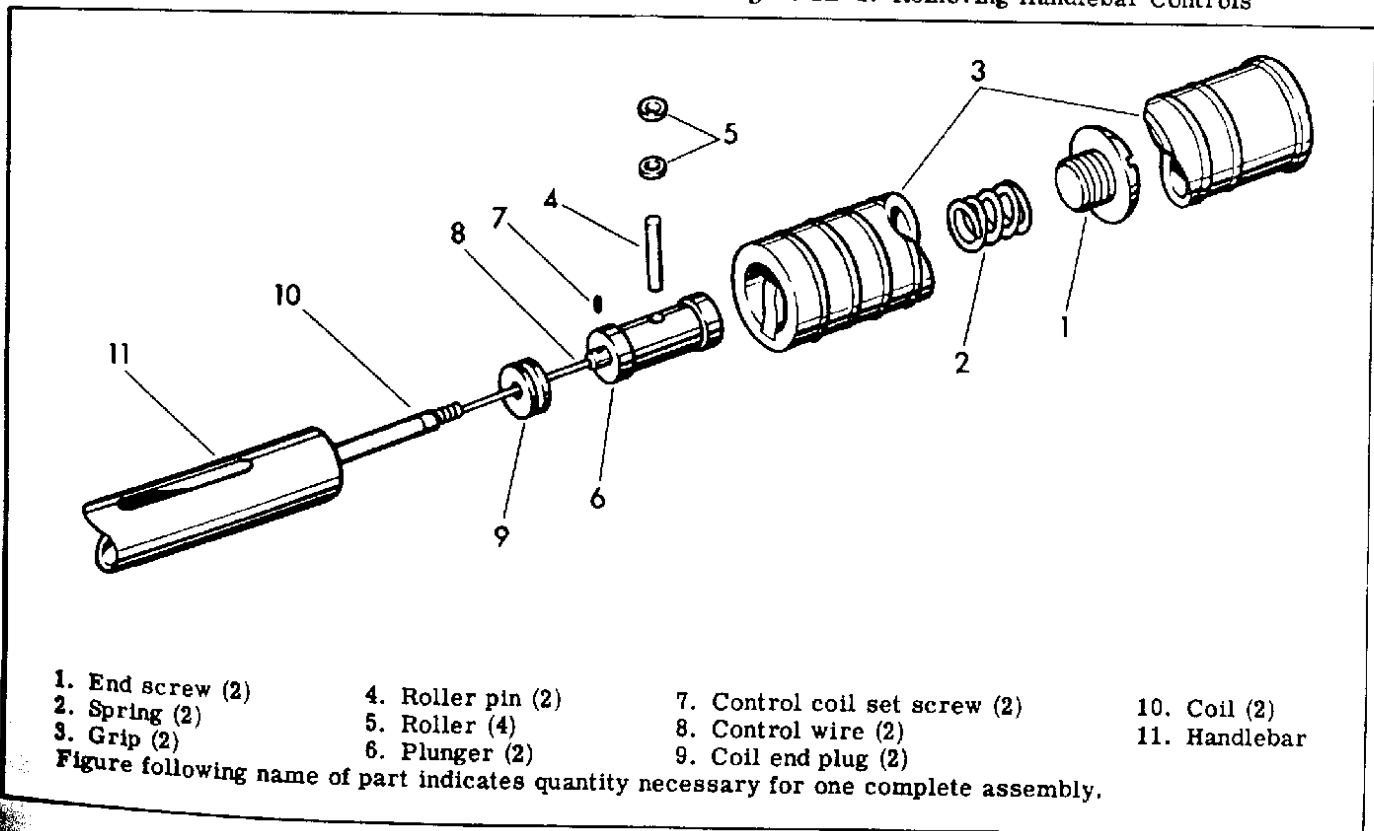

Figure 2D-2. Handlebar Controls - Exploded View

## Notes

Disconnect control coil and wire at carburetor or circuit breaker. Loosen clip which secures spark control coil to upper frame tube.

Insert a large screwdriver through hole in end of grip as shown in Fig. 2D-1 and loosen handlebar end screw (1). Handlebar end screw and spring (2) will remain inside grip. Remove grip sleeve assembly (3), exposing working parts.

Slip two rollers (5) off roller pin (4) and remove roller pin from plunger (6). Plunger with control wire (8) may be pulled through handlebar. If the control wire is broken, remove lower end at carburetor or circuit breaker. The control wire is fastened into the end of the plunger by means of set screw (7).

If control coil is to be removed, loosen the lock screw under the horn or starter button retainer on the handlebar that positions the coil end plug (9) in handlebar. The throttle end plug lock screw is exposed on the underside of the right handlebar. After loosening, control coils and end plugs may be pulled out of handlebar ends.

### INSPECTION AND REPAIR

Clean all parts in solvent. Be sure they are free from rust, gum and dirt. Inspect all parts including inside of grip and replace all worn parts.

### ASSEMBLING HANDLEBAR CONTROLS (Fig. 2D-2)

Slip control coil through handlebar and secure at end plug with lock screw through handlebar (screw must register in groove of end plug). Slip roller pin through plunger and assemble rollers to ends of roller pin, rounded side out. Attach control wire to plunger assembly by means of the set screw (7).

Apply a light coat of grease or oil to control wire as it is inserted into coil. Lubricate remaining parts with grease. Turn grip onto handlebar with rollers following spiral grooves inside grip.

Handlebar end screw may be started without danger of crossing threads by holding grip sleeve assembly back slightly when starting screw in handlebar end. This squares screw with end of grip sleeve, aligning threads. Tighten screw securely.

Connect throttle and/or spark control wires at carburetor and circuit breaker. Adjust throttle control so throttle closes and opens fully with grip movement. Allow about 3/8 in. of throttle control coil to extend beyond carburetor control coil clip when throttle is in a closed position.

With circuit breaker in fully-advanced position, the end of the spark control wire must point directly at hole in timer adjuster stud. Allow about 3/8 in. of spark control coil to extend beyond clamp. Adjust spark control so circuit breaker advances and retards fully with spark control grip movement.

## REMOVING AND INSTALLING FORKS

Spring fork only can be removed and replaced, or complete fork assembly (spring and rigid fork) can be removed and replaced as a unit.

### Removing Spring Fork

1. Set motorcycle on rear stand.
2. Remove spring rod lock nuts (acorn-type).
3. Sit on front mudguard, or otherwise provide weight, to compress fork cushion (lower) springs. The spring rod larger nuts can then be easily removed, freeing upper recoil and upper bumper springs for removal.
4. Free lower end of horn assembly from horn bracket on mudguard.
5. If motorcycle is equipped with ride control, free the two eye bolts (10) and (12) Illus. 153, from spring fork crown; if equipped with shock absorber, remove the two bolts (T), Illus. 152.
6. If motorcycle is equipped with mudguard lamp, disconnect lamp wire from terminal on ignition-light switch and tie a piece of string approximately 30" long to wire terminal. Pull wire out of loom and untie or cut string, allowing it to extend through each end of loom. String will be used when reassembling to pull wire back through loom.
7. Raise front end of motorcycle high enough to permit removing front wheel and front mudguard—support motorcycle by means of suitable blocking underneath frame.
8. Remove front wheel. See "Removing Front Wheel."
9. Remove brake assembly from left rocker plate, after disconnecting brake shackle from rigid fork.
10. Remove front mudguard, after removing nuts and locks from rocker plate rear studs, and the two bolts securing mudguard to rigid fork.
11. Remove rocker plate studs and rocker plates assembled.
12. Remove spring fork from motorcycle.

### Installing Spring Fork

13. Place buffer springs and lower cushion springs on spring rods. Apply grease to rods. Pass rods

up through spring rod bushings in rigid fork bracket. Bind lower end of spring fork to lower end of rigid fork with a strap or piece of heavy wire, to prevent forks from separating while compressing cushion springs.

Note: Before installing spring fork note type of rigid fork used. Earlier type rigid fork stem upper end and fork side upper ends were on same center line, whereas, center line of later type rigid fork stem upper end is  $\frac{3}{8}$ " to rear of fork side center line.

There are three different spring forks which can be used with rigid forks as follows:

Any spring fork used with an earlier type rigid fork can be installed with either side of fork crown facing rear.

If earlier type spring fork (fork crown not milled, approximately  $\frac{7}{8}$ " wide at center lower section) is to be used with later type rigid fork it will be necessary to remove sufficient metal from one side of fork crown lower center section to allow clearance for steering damper steel disc when fork is installed.

If later type spring fork (one side of fork crown milled) is to be used with later type rigid fork, install spring fork with milled side facing rear to allow clearance for steering damper steel disc.

If latest type spring fork (fork crown not milled approximately  $\frac{5}{8}$ " wide at center lower section) is to be used with later type rigid fork, spring fork can be installed either way.

14. Insert two bolts in rigid fork bracket which mount the mudguard. Place a rod about 8" long and  $\frac{1}{2}$ " or larger diameter, on and across rigid fork brackets, resting it against the two bolts inserted in fork brackets. This rod will serve as a pry base for the leverage bar when compressing cushion springs. With a leverage bar about 18" long, anchored on top of the pry base rod and under the spring fork, lift upward to compress cushion springs sufficiently to install one of the rocker plates—then install the other rocker plate.
15. Install front mudguard.
16. Install front brake assembly on left rocker plate, and connect brake shackle to rigid fork.



17. Install front wheel.
18. Install upper bumper springs and upper recoil springs on the spring rods.
19. Remove blocking from underneath motorcycle frame.
20. Sit on mudguard to compress fork cushion (lower) springs. Tighten the two larger spring rod nuts sufficiently to provide 7/16" thread for the spring rod lock nuts (acorn-type). Install spring rod lock nuts and tighten.
21. If motorcycle is equipped with ride control, insert the two eye bolts (10) and (12) Illus. 153, through holes in spring fork crown; if equipped with shock absorber, insert the two bolts (T) Illus. 152, in spring fork crown. Install nuts and washers and tighten nuts securely.
22. Attach lower end of horn assembly to horn bracket on mudguard.
23. If motorcycle is equipped with mudguard lamp, tie string to wire terminal, pull wire through loom and connect wire to ignition-light switch terminal from which it was removed.
24. After assembly has been completed, check front wheel brake for correct adjustment.

### Removing Complete Fork Assembly

1. Set motorcycle on rear stand.
2. Disconnect battery negative wire at frame (ground) connection.
3. If motorcycle is equipped with spotlamps mounted on fork bracket, disconnect lamp wires and remove bracket with lamps attached.
4. If motorcycle is equipped with mudguard lamp, disconnect lamp wire from terminal on ignition-light switch and tie a piece of string approximately 30" long to wire terminal. Pull wire out of loom and untie or cut string, allowing it to extend through each end of loom. String will be used when reassembling, to pull wire back through loom.
5. Remove headlamp and disconnect its wires.
6. Disconnect all remaining wires from insulated junction terminals on horn bracket or lamp bracket, and also from horn.
7. Free cables and any wires from cable retaining clips on right and left sides.
8. Remove headlamp bracket and horn assembly.
9. Remove ride control, or shock absorber, if motorcycle is so equipped.
10. Raise front end of motorcycle high enough to permit removing front wheel and front mudguard—support motorcycle by means of suitable blocking underneath frame.
11. Remove front wheel. See "Removing Front Wheel."
12. Remove brake assembly from left rocker plate after disconnecting brake shackle from rigid

fork. Free front brake cable housing from clamp on rigid fork.

13. Remove front mudguard, after removing nuts and locks from rocker plate rear studs, and the two bolts securing mudguard to rigid fork.
14. If motorcycle is equipped with steering damper, remove lock nut from steering damper rod, then remove upper end parts in the following order: adjusting nut, keyed steel washer, fiber washer, operating lever, and actuating sleeve. This entire assembly is located in the central part of the handle bar mounting bracket. Steering damper rod, cushion spring, pressure disc, fiber disc, and steel disc assembly can now be withdrawn (downward) from fork stem hole.
15. Remove handlebar lock nut and cone lock plate.
16. Loosen the two handlebar pinch bolts, and with a rawhide mallet, or a hammer and a block of wood, drive handlebars off fork ends. There will be enough slack in throttle and spark control wires and housings without loosening or disconnecting them when driving off handlebars. After handlebars have been driven off, swing them to left side of motorcycle and let them hang by control wire housing, placing cloth or other suitable padding as needed, to protect finish.
17. Remove upper head cone (adjusting cone) from fork stem, thereby freeing fork assembly for removal from frame head. When removing fork assembly, be careful that none of the balls in head cups drop out and become lost. Remove all balls from head cups.

### Disassembling and Assembling Forks

1. Clamp fork stem in suitable vise.
2. Remove rocker plates.
3. If forks have spring rod bushing retaining plate, remove bolt from center of plate.
4. With suitable "C" clamp, decompress fork recoil springs and remove nuts from ends of spring rods.
5. Decompress cushion springs and spring fork is then free for removal.
6. Assemble forks in reverse order of disassembly. See paragraph 13, under "Installing Spring Fork."

### Installing Complete Fork Assembly

1. Thoroughly clean and inspect balls, cones and head cup ball races. If any are found worn or damaged, renew.
2. Put a liberal amount of Harley-Davidson grade "A" grease in each head cup and then place 17 balls in each cup. Insert fork stem through frame head and install upper head cone (adjusting cone). Adjust head cone so there is no per-

ceptible shake in bearing; however forks must turn freely.

- 3. Drive handlebars onto fork ends, using a rawhide mallet, or a hammer and a block of wood.

Install cone lock plate, entering pin through hole in handlebars and engaging a notch in adjusting cone. Install and tighten handlebar nut securely. *When tightening this nut, always make sure that register on nut enters hole in lock plate and handlebars.* Check steering head bearing adjustment, as tightening lock nut may have changed this adjustment slightly. The fork must turn freely without perceptible shake. If necessary to readjust, remove handlebar lock nut and cone lock plate and turn adjusting cone, clockwise for less shake or counter-clockwise if too tight. It is not necessary to remove handlebars to turn adjusting cone; cone may be turned by tapping cone at lock pin notches with a pin punch and light hammer. Cone must be adjusted so pin on cone lock plate is free to enter hole in handlebar center forging and go on through to engage a notch in the cone. Adjusting cone lock plate and lock nut must be securely tightened for each check. When desired setting is obtained, tighten handlebar pinch bolts securely.

- 4. Install steering damper if motorcycle is so equipped. See "Steering Damper,"
- 5. Install front mudguard.
- 6. Install front brake assembly on left rocker plate, and connect brake shackle to rigid fork.
- 7. Install front wheel.
- 8. Remove blocking from underneath motorcycle frame.
- 9. Install headlamp bracket with its rear connection arm below handlebar lug.
- 10. Install ride control or shock absorber if motorcycle is so equipped. See Illus. 151 showing shock absorber installed.
- 11. Install horn assembly.
- 12. If motorcycle is equipped with mudguard lamp, tie string to wire terminal, pull wire through loom and connect wire to ignition-light switch terminal from which it was removed.
- 13. Connect headlamp wires and install headlamp.
- 14. Install spotlamps together with bracket if motorcycle is so equipped.
- 15. Connect all remaining wires that were disconnected before removing fork assembly. Refer to wiring diagram that applies as to model and electrical equipment.
- 16. Secure cables, and any wires originally secured, with retaining clips, on right and left sides.
- 17. Secure front brake cable housing with clamp on rigid fork.
- 18. After assembly has been completed, check front wheel brake for correct adjustment.

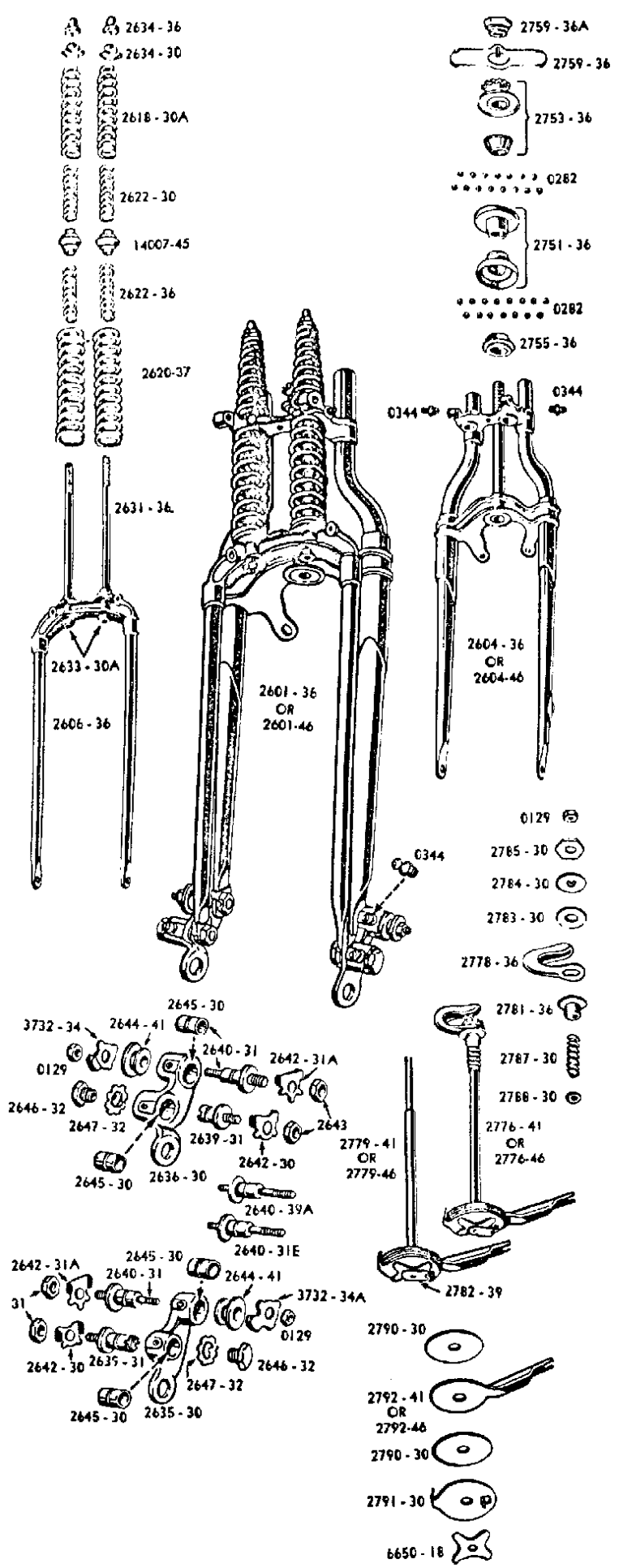

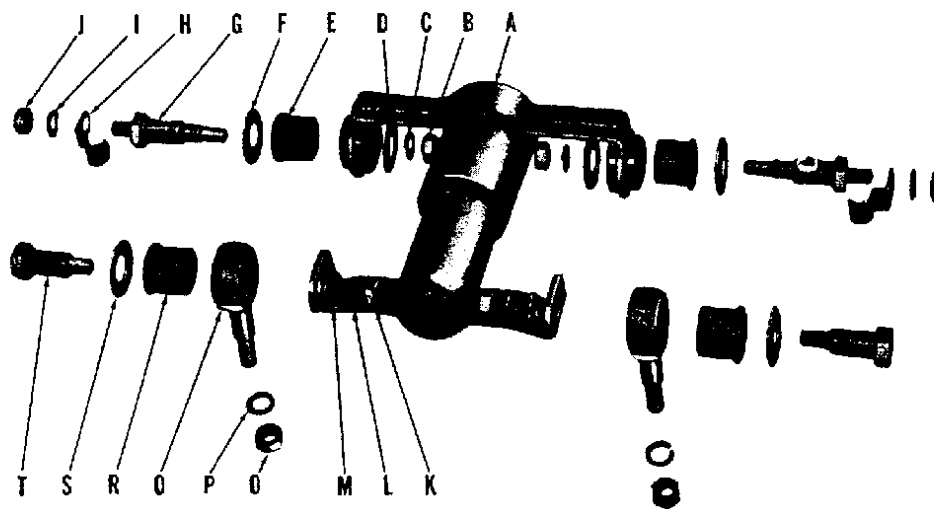

ILLUS. 152  
HYDRAULIC SHOCK ABSORBER DISASSEMBLED

### SHOCK ABSORBER ASSEMBLY

NOTE: Items on unlettered side are a duplicate of items on lettered side, and total number of items for both sides are given under "NUMBER USED."

ITEM	NUMBER USED	PART NUMBER	NAME
A	1	54206-45	Shock Absorber (less all fittings)
B	8	7793	Shock Absorber Stud Nut (same as Items J, K and O)
C	8	7045	Lock Washer (same as Item I, L and P)
D	6	6395	Plain Washer (same as Items F and S)
E	4	54216-45	Shock Absorber Rubber Bushing (same as Item R)
F	See Item D and S		.....
G	2	54219-45	Shock Absorber Upper Stud
H	2	9973	Wire Clamp
I	See Items C, L and P		.....
J	See Items B, K and O		.....
K	See Items B, J and O		.....
L	See Items C, I and P		.....
M	2	0224	Plain Washer
O	See Items B, J and K		.....
P	See Items C, I and L		.....
Q	2	54220-45	Eye Bolt
R	See Item E		.....
S	See Items D, and F		.....
T	2	54224-45	Shoulder Bolt

## FORK, FRAME AND HANDLEBAR ALIGNMENT

### Rough Check for Fork Alignment

Obtain a perfectly straight  $7/16$ " diameter round bar about 30" long. Turn down one end of rod to  $3/8$ " diameter for a distance of approximately 1".

Rough check rigid fork for alignment as follows: Temporarily install a steering damper screw in fork stem upper end. Referring to Illus. 146, pass  $7/16$ " bar through hole in fork center stem with  $3/8$ " diameter end entering hole in steering damper screw to determine if fork sides are parallel with center stem. As shown in illustration the fork side tips should be  $3-45/64$ " from the sides of test bar.

Upper end fork sides and fork stem must be spaced to fit handlebar mounting holes.

Fork sides can be checked for relative alignment by using two perfectly straight  $5/16$ " diameter round bars at least 18" long. Referring to Illus. 147, note that fork is to be supported in horizontal position on level blocks or by clamping center stem in a vise. Insert one rod through holes in lower fork tips and lay the other squarely across upper end of forks. Sight across the two rods and note their relative alignment. If they are not in close alignment, either one or both of the fork sides are not straight, or possibly the fork sides are straight enough, but they are out of alignment with each other, or across the fork, due to a twist in the fork crown.

This method of checking fork alignment is recommended only in connection with emergency repair. Except in emergency, fork straightening and aligning should be referred to a shop where any needed straightening equipment and more accurate aligning gauges are available.

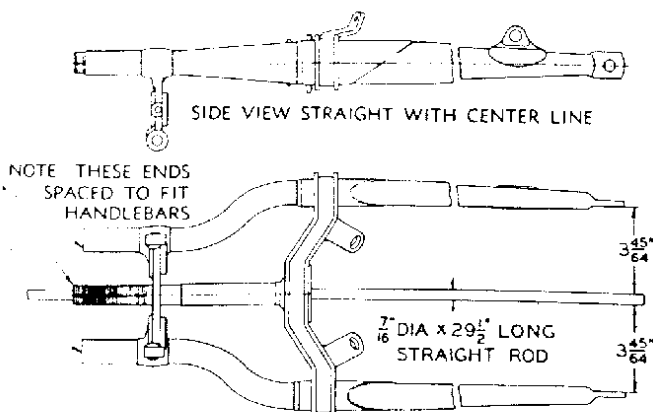

ILLUS. 146

CORRECT ALIGNMENT OF FORK SIDES WITH FORK STEM

### Rough Check for Frame Alignment

Sketch (Illus. 148) shows a satisfactory method of rough checking a frame that is not visibly badly damaged but there is doubt as to its possible alignment. This check will determine whether or not frame is far enough out of alignment to require either a major re-aligning job or replacement. Straightening a badly bent frame requires special tools and fixtures for holding, bending and gauging.

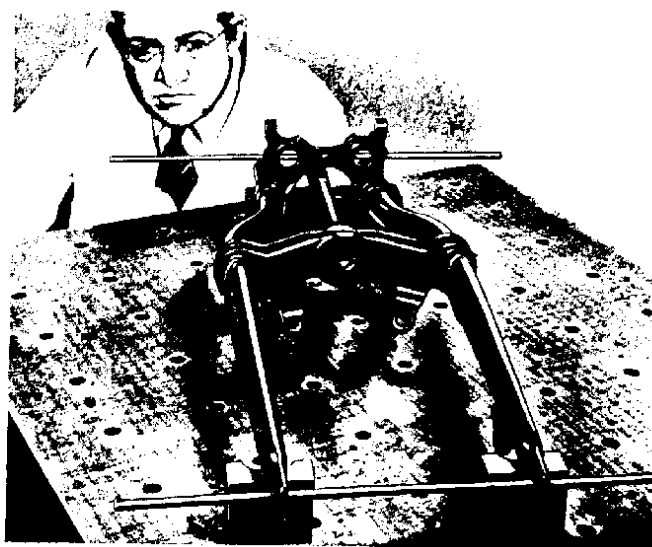

ILLUS. 147

VISUAL CHECK OF FORK SIDE RELATIVE ALIGNMENT

The straight edge must be perfectly straight and can be either a 1" rod, or a rectangular bar 1" wide and  $1/2$ " thick or of sufficient thickness so that it is rigid. Its length should be 65" or more.

The gauge rod can be any straight  $3/8$ " diameter —24 thread rod at least 6" long. It is to be installed in transmission mounting plate left rear bolt hole.

The shim must be  $5/16$ " thick and approximately 3" long. It is to be inserted between straight edge and  $3/8$ " gauge rod.

The round bar for head must be  $1-3/64$ " in diameter and at least 32" long. A shoulder or pin may be provided at top end of bar to prevent it from passing all the way through frame head. Bearing cups are left in frame head when using gauge bar.

Sketch includes measurements for checking alignment.

#### NOTE

Replace all badly bent or broken frames. The cost of repair would be prohibitive.

To rough check a frame for correct alignment, see The dimensions shown will provide basic information to determine whether a frame is enough out of alignment to require a major realigning job or replacement.

Straightening a badly bent frame requires special tools and fixtures for holding, bending and gauging. If frame straightening facilities are not available locally, damaged frames may be returned to the factory for repair (through authorized Harley-Davidson dealers only).

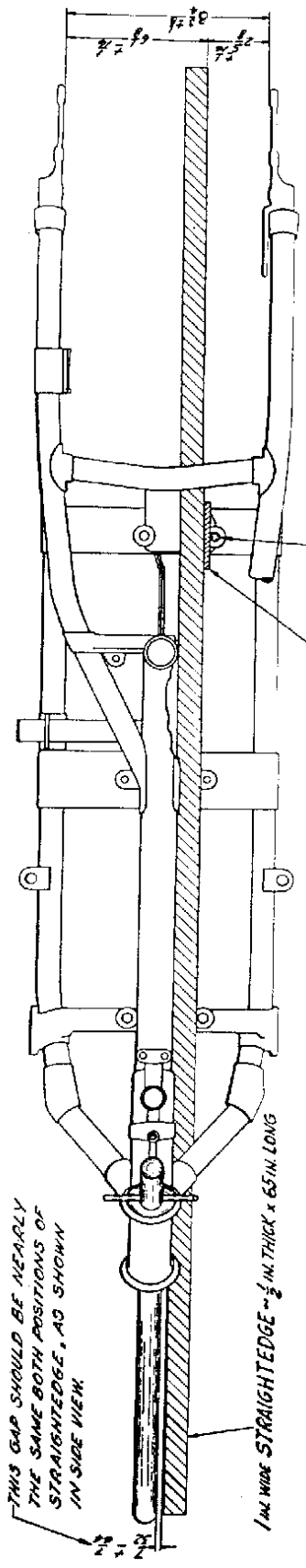

5/16 IN. THICK x 3 IN. LONG SHIM

3/8 IN. DIA. STRAIGHT ROD, 6 INCHES LONG, 2 1/2 INCH THD. AT LEAST 1/2 IN LONG ON ONE END. (45° MODEL FRONT AXLE PART NO. 3910-30 WILL DO) ROD MUST BE SCREWED TIGHT INTO LEFT REAR TRANSMISSION SUB MOUNTING PLATE CAP SCREW HOLE.

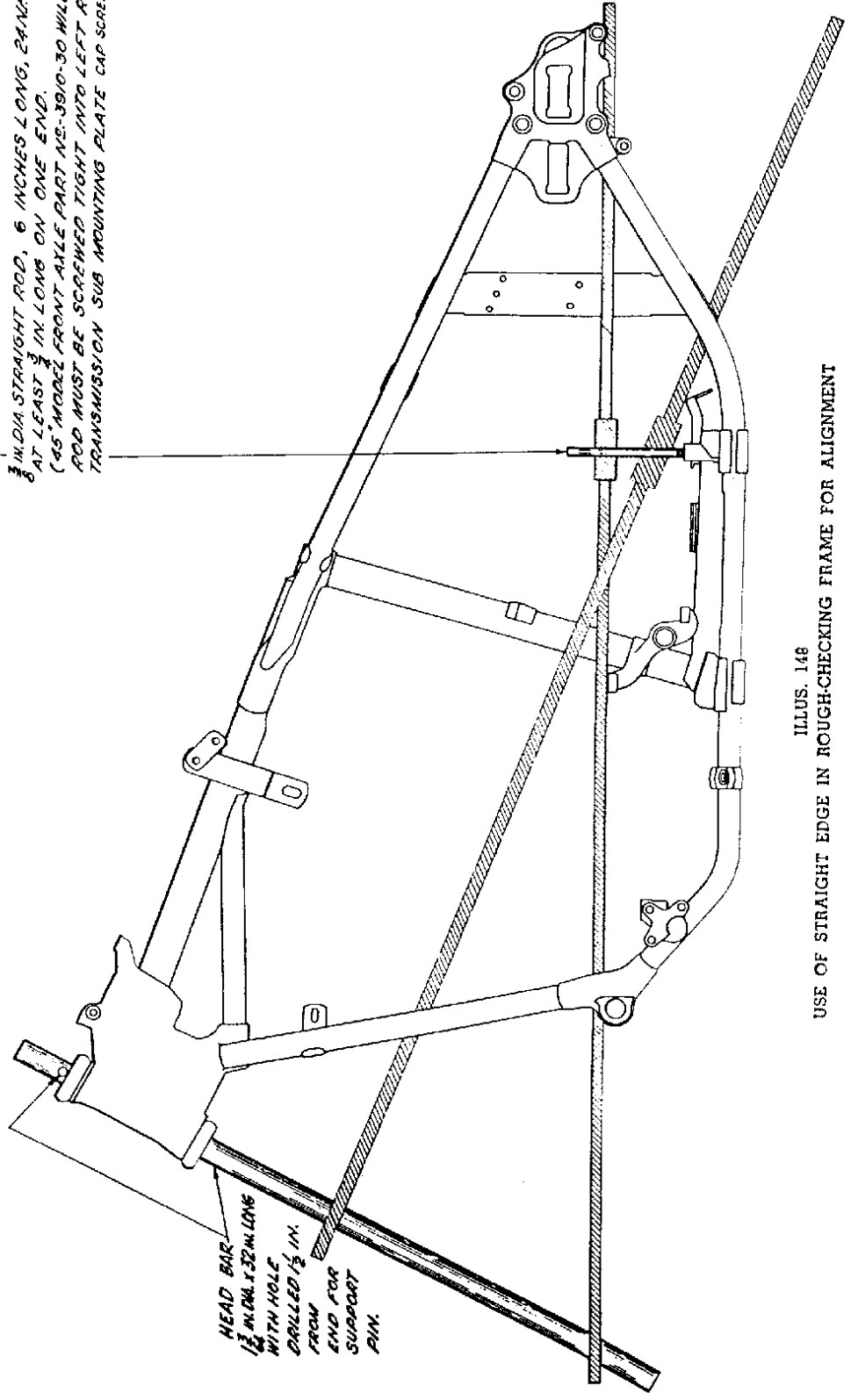

ILLUS. 148 USE OF STRAIGHT EDGE IN ROUGH-CHECKING FRAME FOR ALIGNMENT

## HYDRA-GLIDE FORKS

### GENERAL

The Hydra-Glide fork is comprised of two sets of telescoping tubes that work against springs, with an oil filled (hydraulic) dampening mechanism to control the action. The unit is engineered to give long service with a minimum of repair. Usually, only periodic (approximately 5000-mile intervals) oil change is necessary.

**GLIDE (NON-ADJUSTABLE).** The non-adjustable Glide fork, as illustrated in Fig. 2F-3, is for use on a solo motorcycle. The fork "trail" (the distance, at ground level, from the fork stem axis to a perpendicular through the wheel axle) is set and cannot be adjusted. This fork may be recognized by the two hexagon head upper bracket bolts (2, Fig. 2F-3) in the slider tube tops.

**GLIDE (ADJUSTABLE).** The adjustable Glide fork is for use on a motorcycle which operates with and without a sidecar. It is essentially the same as the non-adjustable fork except it has a two-position bracket that allows the trail to be changed for best solo or sidecar-equipped operation, also a steering damper adjusting mechanism which dampens the steering head to suit conditions and rider preference. All other adjustments and repairs are made exactly as on the non-adjustable fork. This fork may be recognized by the reversible bracket bolt washers, bolt and stem design (18, 19, 20, Fig. 2F-4) as described in "Adjusting Front Fork Trail."

**SERVI-CAR (NON-ADJUSTABLE).** The Servi-Car fork is a combination of the above forks. It has greater trail than the non-adjustable Glide fork, but is itself non-adjustable. The stem and bracket are the same as the adjustable fork except for the bracket bolt washers. In appearance, it is similar to the adjustable fork.

### CHANGING OIL

**GLIDE (NON-ADJUSTABLE).** Remove upper bracket bolt (2, Fig. 2F-3) at top of each fork tube.

**GLIDE (ADJUSTABLE) AND SERVI-CAR.** Remove fork cover side panels or headlamp housing and fork filler screws (23, Fig. 2F-4).

**ALL MODELS.** Remove drain plug, Fig. 2F-3 at the outside bottom of each slider tube with a 3/16 in. Allen wrench and drain. Draining speed will be increased by gently flexing the fork as it empties. Replace drain plugs and pour 6-1/2 oz. of Harley-Davidson Hydra-Glide Fork oil into each tube, 7 oz. if fork has been disassembled and washed. Measure amount very carefully. Flow of oil into tubes will be increased if fork is worked up and down during filling operation. Replace upper bracket bolts and tighten securely.

The fork filling device shown in Fig. 2F-1 will hasten and simplify the filling operation. The unit consists of a Neoprene (not rubber) stopper to fit the hole in the top of the fork, a length of flexible tubing, a funnel and an appropriate size can, soldered to the top of the funnel.

To make a filler can, drill a dozen 1/4 in. holes in the bottom of a one quart tin can (2), near the outside edge. Shape the bottom of the can with a light hammer so that it is dished upward to assure complete draining of oil through the holes.

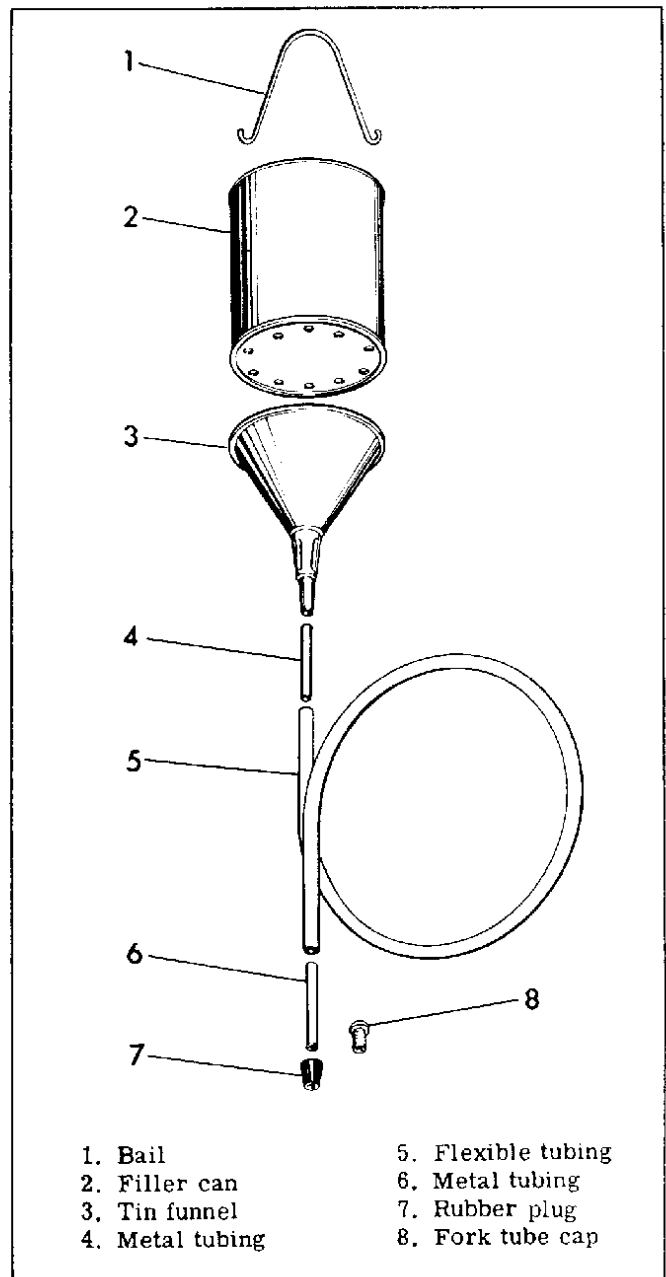

- |                 |                    |
|-----------------|--------------------|
| 1. Bail         | 5. Flexible tubing |
| 2. Filler can   | 6. Metal tubing    |
| 3. Tin funnel   | 7. Rubber plug     |
| 4. Metal tubing | 8. Fork tube cap   |

Figure 2F-1. Fork Filler Can Components

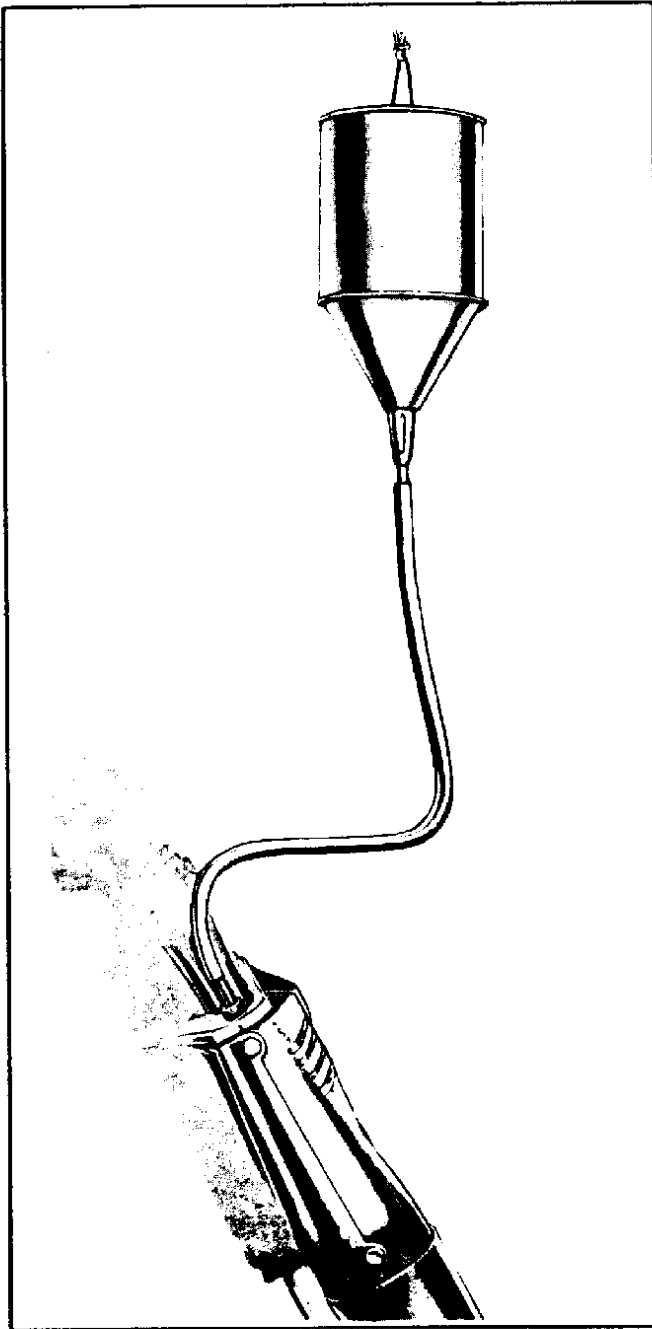

Figure 2F-2. Filling Hydraulic Fork with Oil

Select a tin funnel (3) with the funnel mouth about the same size as the bottom of can (2). Swage and shape the funnel spout so that a piece of 1/4 in. metal tubing (4), about 2 in. long, (a piece of fuel line is suitable) can be soldered into it. Solder (3) onto the bottom of (2). Improvise and attach ball (1) to the filler can.

Make plug (7) from a rubber bottle stopper purchased from a drug store. Rubber stopper should be 1 in. to 1-1/8 in. long, and its largest diameter about 5/8 in.

Hold rubber stopper in vise and drill a 3/32 in. hole lengthwise through the center. Then enlarge the hole with a 1/4 in. drill. After hole is drilled in the stopper, insert a 1/4 in. rod through the hole and grind

#### KEY FOR FIGURE 2F-3

1. Fork stem nut
- 1A. Nut lock (63 models)
2. Fork upper bracket bolt and valve (2)
3. Tube plug oil seal (2)
4. Fork upper bracket cover
5. Handlebar and fork bracket
6. Head bearing nut
7. Head bearing (2)
8. Fork bracket clamping stud (2)
9. Fork bracket with stem
10. Fork slider cover (2)
11. Slider tube plug (2)
12. Fork spring (2)
13. Damper valve stud lock nut (2)
14. Fork slider tube (2)
15. Slider tube snap ring (2)
16. Damper tube bushing gasket (2)
17. Damper tube lower bushing (2)
18. Damper valve stud gasket (2)
19. Damper tube valve (2)
20. Spring ring (2)
21. Spring ring washer (2)
22. Upper oil seal felt washer (2)
23. Upper oil seal (2)
24. Slider (2)
25. Slider upper and lower bushing (2 each)
26. Head bearing (see item 7)
27. Lower head bearing guard

Figure following name of part indicates quantity necessary for one complete assembly.

the stopper to a 5/8 in. diameter at the large end, and slightly under 1/2 in. diameter at the small end, straight taper between ends, to form the plug.

Slightly flare one end of a piece of 1/4 in. tubing (6), about 2 in. long and insert into plug (7). Attach filler can to plug with transparent flexible tubing (5) about 2 feet long. See Fig. 2F-2.

Push the plug into the filler hole in fork top, Fig. 2F-2. Pour exact amount of oil into can. Work fork up and down. Air escaping through oil in filler can as fork is pushed downward will cause the oil to bubble violently, but because the bottom of the can serves as a baffle, no oil will be lost. Compressing the fork forces air out, releasing it draws oil into fork.

After the can appears to be empty, allow several minutes for can to completely drain then work fork once more. This assures getting into fork side the full quantity of oil poured into can.

#### INSPECTION PROCEDURE

If hydraulic fork does not work properly; that is, if it leaks oil or lacks original snubbing action, check the following before disassembling:

If oil leaks from vent hole in upper bracket bolt (2, Fig. 2F-3 and filler screw 23, Fig. 2F-4) when fork flexes, check for over-filling. Drain and refill with exact amount of oil.

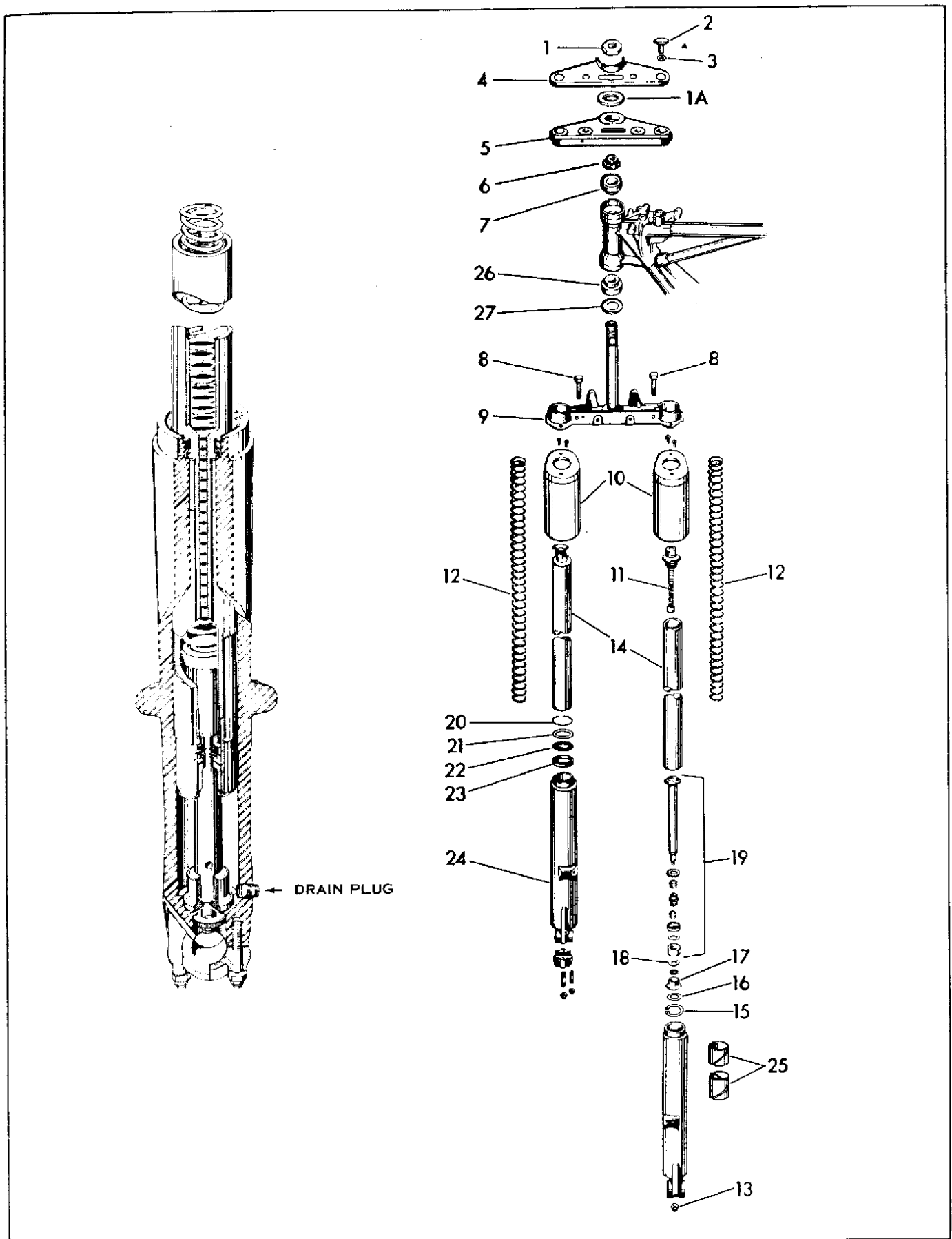
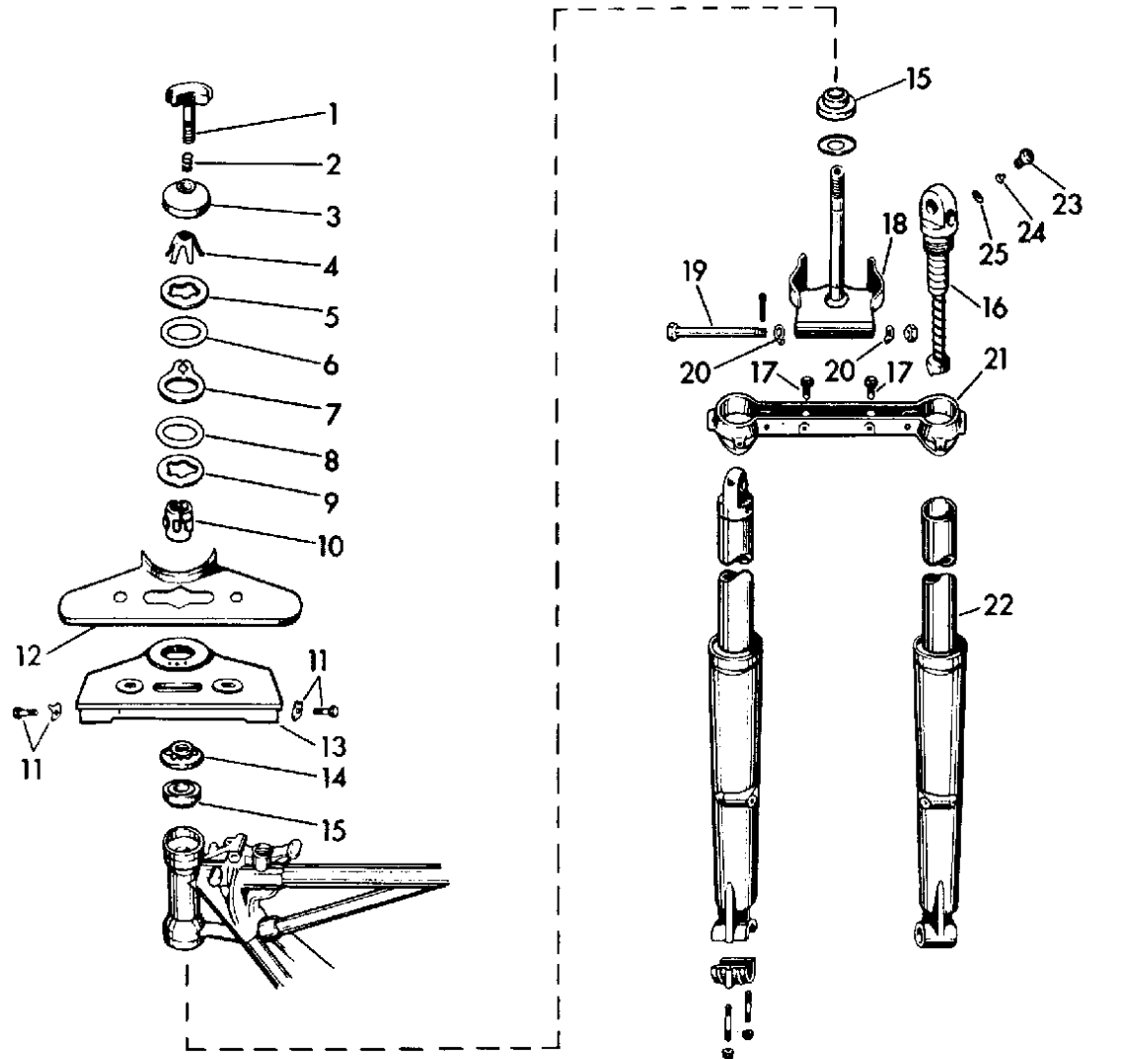

Figure 2F-3. Hydra-Glide Fork - Exploded View





- |  |  |
|--|--|
| 1. Steering damper adjusting screw         | 14. Head bearing nut                     |
| 2. Spring                                  | 15. Head bearing (2)                     |
| 3. Spider spring cover                     | 16. Slider tube plug (2)                 |
| 4. Spider spring                           | 17. Bracket clamping stud (2)            |
| 5. Pressure disc (2)                       | 18. Bracket with stem                    |
| 6. Friction washer (2)                     | 19. Bracket bolt with nut and cotter pin |
| 7. Anchor plate                            | 20. Bracket bolt washer (2)              |
| 8. Friction washer (see item 6)            | 21. Bracket                              |
| 9. Pressure disc (see item 5)              | 22. Fork tube and slider assembly (2)    |
| 10. Fork stem nut                          | 23. Filler screw (2)                     |
| 11. Upper bracket bolt and washer (2 each) | 24. Filler screw valve (2)               |
| 12. Upper bracket cover                    | 25. Filler screw washer (2)              |
| 13. Upper bracket                          |  |

Figure following name of part indicates quantity necessary for one complete assembly.

Figure 2F-4. Adjustable Fork - Exploded View

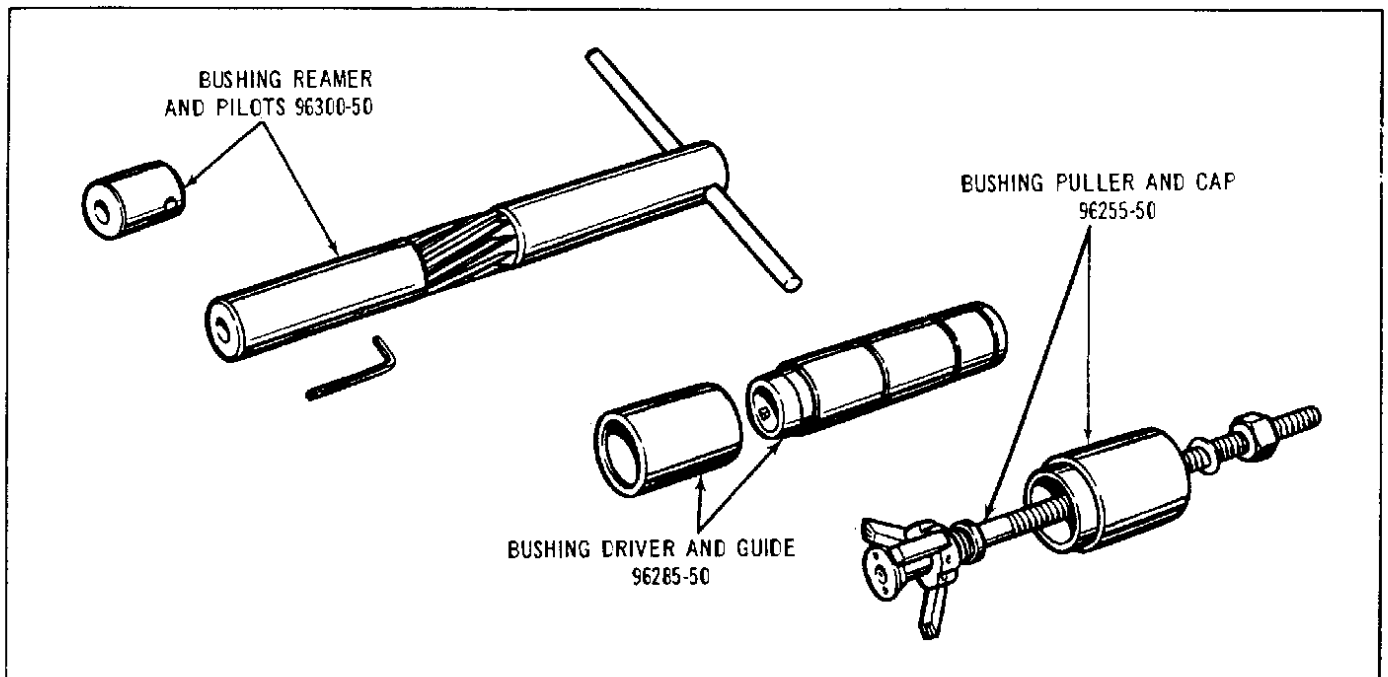

Figure 2F-5. Fork Rebushing Tools

If oil leaks from vent hole in upper bracket bolt when fork tubes contain correct amount of oil, check breather valve in upper bracket bolt or hole. To replace breather valve, place bolt in vise and tap back three stake locks with small punch and hammer. Pry valve from recess with length of stiff wire. If unable to free valve, drill hole in valve larger and pry valve out with small pin or screwdriver. In some cases, it is necessary to drill and tap hole in valve and pull it out with tap. Insert new valve assembly and stake three spots on bolt lip.

If fork action is stiff or soft and spongy and breather valves are functioning and oil content is correct, damper valves in fork tubes are inoperative. Fork must be disassembled. If fork is submerged in water, oil must be replaced at once. Water will rust damper tube valve parts. In neglected cases, the valves may stick and result in almost no snubbing action.

If oil bypasses slider tube bushings and leaks at top of sliders, bushings are worn and must be replaced. To replace slider bushings, fork must be disassembled. If slider bushings are worn, water will contaminate oil. Oil will appear emulsified, aerated and light brown.

If fork slider has play on slider tubes, bushings are worn and must be replaced. Fork must be disassembled. However, it is not necessary to disassemble entire fork and steering head unless desired.

#### DISASSEMBLING FRONT FORK SLIDER AND TUBES

If necessary repairs involve only sliders and slider tubes, the entire fork need not be disassembled.

To remove sliders and slider tubes, proceed as follows:

Remove front wheel as described in "Wheels," Section 2C. Remove front brake hand lever coil clip on fender. Turn off axle sleeve nut and pivot stud nut, and pull brake side cover and shoe assembly plus axle sleeve off fork. Remove front fender.

Loosen fork bracket clamping studs (8, Fig. 2F-3 or 17, Fig. 2F-4). Remove the two upper bracket bolts with oil seals (2 and 3, Fig. 2F-3; 23, Fig. 2F-4). Pull fork slider and slider tube assemblies out bottom of slider covers.

Proceed with fork slider and slider tube disassembly and repair as described in a following paragraph, "Disassembling Front Fork."

#### DISASSEMBLING FORK SLIDER

The slider only may be removed without disassembling remainder of fork assembly as follows:

Remove front wheel axle as described in "Wheels," Section 2C, and fender mounting screws from slider.

Right slider may be removed after turning off damper valve stud lock nut (13, Fig. 2F-3).

To remove left slider, first remove wheel, brake drum and brake side cover as described in "Disassembling Front Fork Slider and Tubes" above, and damper valve stud lock nut (13, Fig. 2F-3).

#### ADJUSTING STEERING DAMPER (GLIDE ADJUSTABLE AND SERVI-CAR)

Turn steering damper adjusting screw (1, Fig. 2F-4) clockwise to apply dampening action and counter-clockwise to reduce dampening action. Apply steering damper only when operating under conditions where some degree of dampening stabilizes steering.

It is best to keep the damper set a little snug when operating with a sidecar.

#### ADJUSTING FRONT FORK TRAIL (GLIDE ADJUSTABLE) (Fig. 2F-4)

To adjust fork trail for use with sidecar, turn off nut on bracket bolt (19). Tap bolt head back far enough to pry out washer (20). Grasp fork tubes and pull forward sharply. It may be necessary to loosen upper bracket bolts (11) to move fork forward or backward. Revolve bracket bolt washers 180 degrees until pin on washer is forward. Seat washer pin in slot in bracket (21) boss. Tap bracket bolt (19) into position and turn on nut.

To adjust fork for solo riding, follow same procedure except push fork tubes back and insert washer (20) so pins are rearward.

#### DISASSEMBLING FRONT FORK

Prepare for disassembling by raising front end of motorcycle on stand or suitable support, so wheel is off the floor.

Remove front and side fork trim panel or headlamp

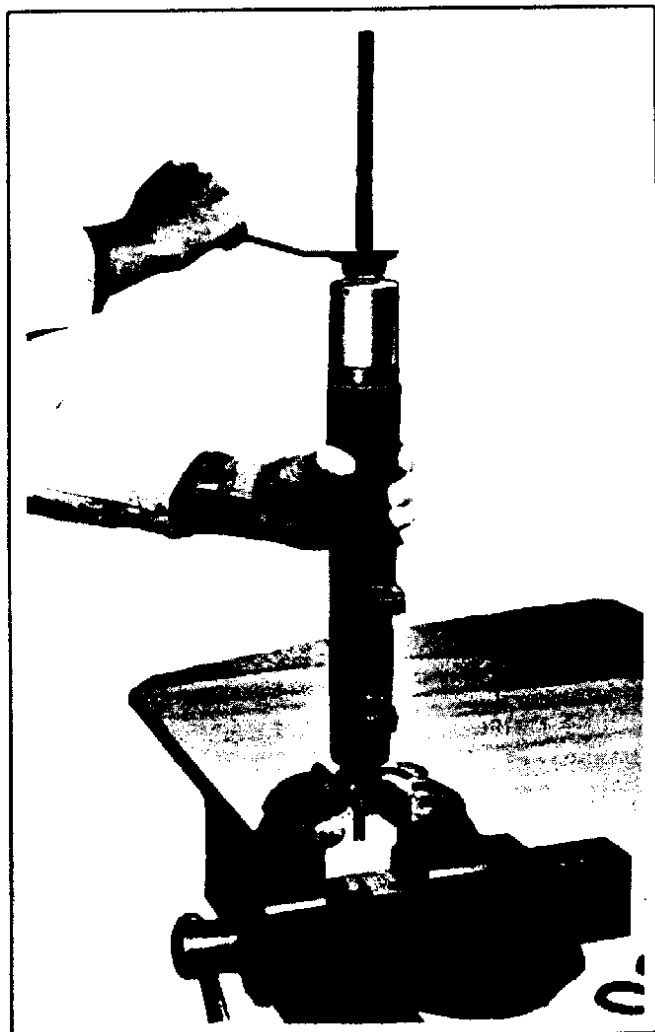

Figure 2F-6. Removing Fork Slider Bushing

housing. Remove headlamp. Disconnect at terminal strip the two headlamp wires and all wires that pass through handlebars. Disconnect throttle and spark advance cables from carburetor and circuit breaker.

Remove front wheel as described in Section 2C. Remove front brake hand lever bracket and coil clip on fender. Turn off front axle sleeve nut and pivot stud nut, and pull brake side cover and shoe assembly and axle sleeve off fork. Remove front fender. Slider bushing play can best be checked at this point. Remove the handlebars.

#### GLIDE (NON-ADJUSTABLE) (Fig. 2F-3)

Remove the fork stem nut (1) and nut lock (1A) (if used). Remove the two upper bracket bolts (2) with oil seal (3) and upper bracket cover (4) (if used). Lift off handlebar and fork bracket (5). Remove head bearing nut (6). Remove upper head bearing (7) and pull fork out bottom of steering head.

Note: Frame head bearing Lock Nut Wrench, Part No. 96219-50, is used to remove nut (6).

Loosen fork bracket clamping studs (8) and slide fork bracket (9) off fork tubes with fork slider covers (10). Turn out two slider tube plugs (11) and invert sliders to drain out oil and remove fork springs (12).

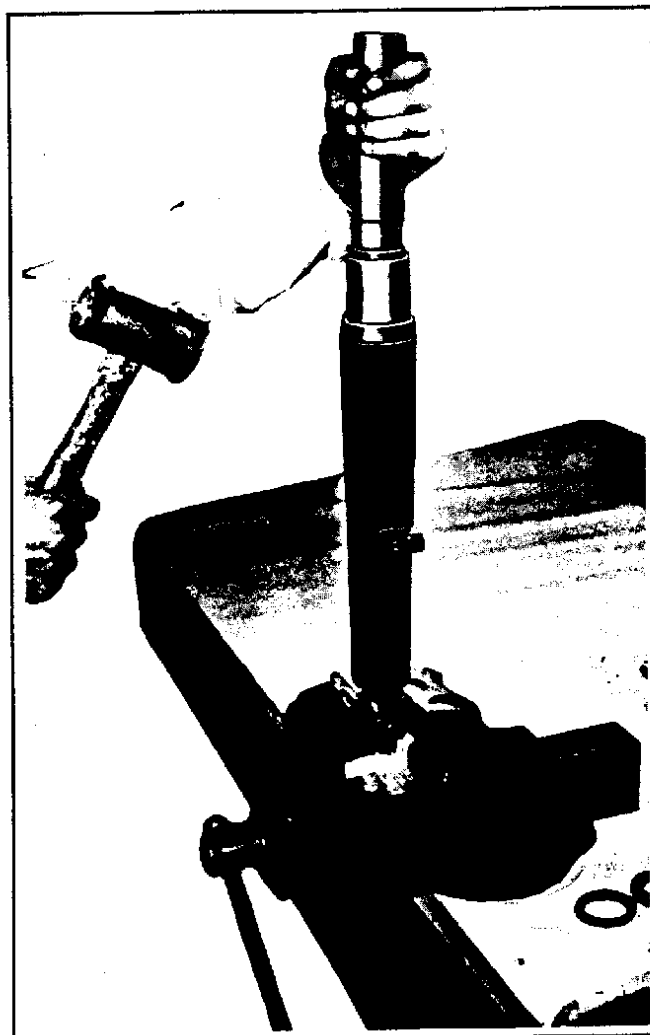

Figure 2F-7. Driving in Fork Slider Bushing

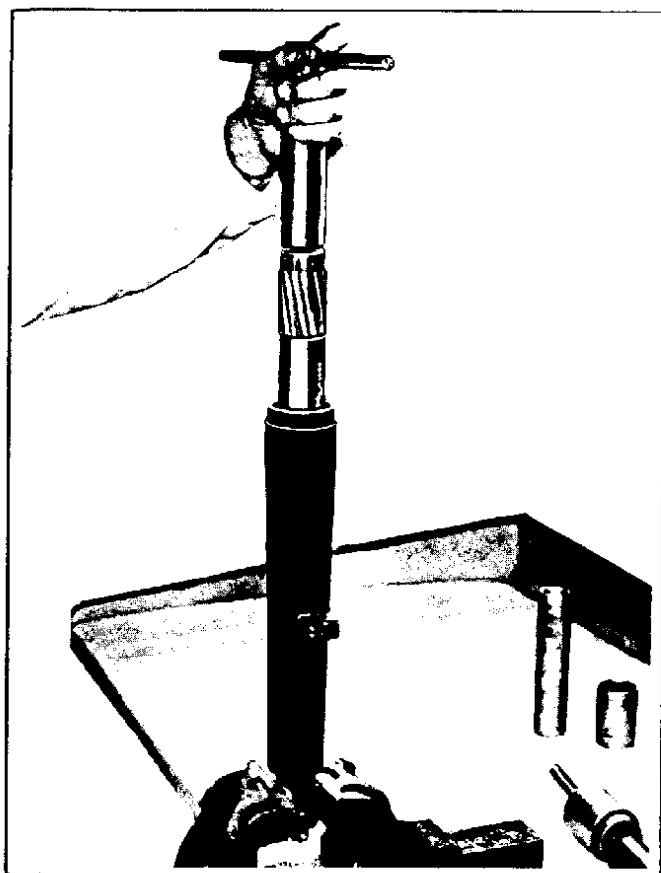

Figure 2F-8. Reaming Replacement Bushing

Remove damper valve stud lock nut (13) from bottom of slider and pull slider tube (14) out of slider (24). Pinch out snap ring (15) from lower end of slider tube and drop out damper tube lower bushing (17). Discard gaskets (16 and 18). Slide out damper valve assembly (19). Snap out spring ring (20), washer (21), felt washer (22) and pry out oil seal (23).

#### GLIDE (ADJUSTABLE) AND SERVI-CAR (Fig. 2F-4)

Prepare for disassembly as described in paragraph above. Turn out steering damper adjusting screw (1) and lift out parts 2 through 9. Parts 5, 7 and 9 may be loosened by inserting a screwdriver tip between parts and prying upward.

Turn off stem nut (10). Remove upper bracket bolts and washers (11) and lift off bracket cover (12) and upper bracket (13). Remove head bearing nut (14). Lift out upper head bearing (15) and slip fork assembly out of frame steering head.

**NOTE:** Frame head bearing Lock Nut Wrench, Part No. 96219-50, is used to remove nuts (10) and (14).

Remove slider tube plugs (16) and loosen clamping studs (17). Slip fork tube and slider assembly (22) out of bracket (21). Slider tube and slider disassembly is the same as described for non-adjustable fork.

#### STEERING HEAD BEARINGS

Each steering head bearing consists of two pieces,

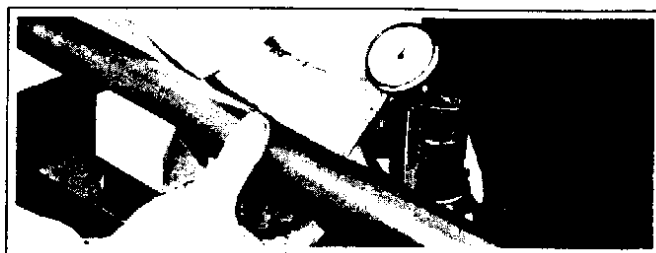

Figure 2F-9. Indicating High Point

the bearing outer race, and the roller bearing with inner race. The outer races are pressed into the steering head cups in the frame head. The lower roller bearing is assembled over the fork stem and the upper roller bearing is held in place on the fork stem by the bearing lock nut on the upper threaded end of the fork stem.

After fork is removed inspect bearings and races for pitting, roughness or wear. Roughness of the roller bearings can be determined by rolling the bearings on the bearing races by hand. If bearings or races require replacement it is best to replace them in sets.

To replace bearing race, knock head cup from steering head using a suitable drift. Press new bearing race in new head cup and then press assembly into frame head. If you wish to use old head cups, holes must be drilled in back side of cup so that race can be driven out by using small diameter drift or by some other improvised means.

#### MEMORANDA

##### REPLACING FRONT FORK SLIDER BUSHINGS

The front fork slider bushings (25, Fig. 2F-3) may be replaced using three special tools.

1. Part No. 96255-50, Fork Slider Bushing Puller.
2. Part No. 96285-50, Bushing Driver and Guide.
3. Part No. 96300-50, Bushing Reamer and Pilots.

**REMOVING SLIDER BUSHINGS.** Position fork slider in vise as shown in Fig. 2F-6.

Remove spring ring, steel retaining washer and felt wiper from slider upper end. Pry out oil seal with large screwdriver.

Install Fork Slider Bushing Puller, Part No. 96255-50, so the three claws expand inside the tube under the upper, or shorter bushing. Place puller cap in oil seal counterbore, apply oil to screw threads and

steel washer. Turn nut down against puller cap and use engine sprocket wrench on nut to extract bushing. See Fig. 2F-6.

Remove lower bushing in the same manner.

**INSTALLING FORK SLIDER BUSHINGS.** New, replacement bushings are installed with Fork Slider Bushing Driver and Guide, Part No. 96285-50.

Wash out fork slider and lubricate slider bore with engine oil. Position new lower bushing in bushing driver guide to compress bushing, then place driver guide with bushing in slider oil seal counterbore as shown in Fig. 2F-7.

Drive bushing through the driver guide into fork slider. Bushing is positioned correctly in slider bore when second groove from top on driver is flush with top edge of driver guide. Do not drive bushing deeper than specified, or it will collapse enough so it cannot be finish-reamed.

Install upper bushing in the same manner lower bushing was installed. Drive it into slider until lower groove on driver is flush with top of driver guide. This positions upper bushing 1/16 in. below slider oil seal counterbore.

**REAMING BUSHINGS.** The Fork Slider Bushing Reamer with pilots, Part No. 96300-50, is used to ream the bushings to finished size.

Attach long pilot to reamer as shown in Fig. 2F-8. The long pilot fits into the unfinished lower bushing, acting as a guide, while reaming the upper bushing. Do not drop reamer into bushing. Slowly lower reamer into cutting position and ream bushing, turning reamer clockwise. Continue turning reamer clockwise as it is being extracted when cut is finished.

Remove long pilot from reamer and attach short pilot. Finish lower bushing in same manner as upper bushing. Use caution when passing reamer cutters through the upper bushing.

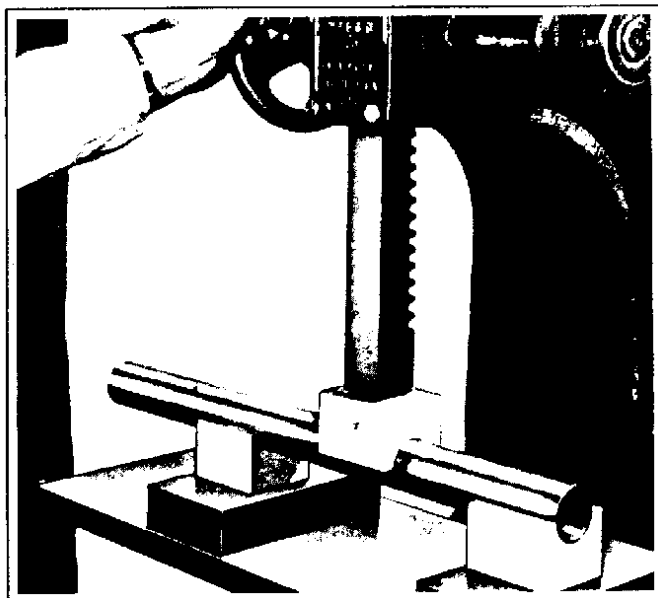

Figure 2F-10. Pressing High Point

## INSPECTING AND SERVICING FRONT FORK

Clean and air dry all parts. Inspect outside of slider tubes and inside of slider for scratches, grooves, nicks and scoring. Minor burrs may be taken off with a fine oil stone. Replace all badly worn parts.

Inspect damper tube valve parts for rust and broken springs. Replace broken springs and all valve parts that are deeply pitted or otherwise in unusable condition.

Inspect slider tube plug for loose or displaced fork upper baffle cups and broken spring. Solder loose cups in place and replace any broken parts. Be sure cups are arranged with slots for oil passage on alternate sides. Improper arrangement may cause oil leak at upper bracket bolt.

## STRAIGHTENING FORK TUBES

Straightening fork tubes requires several special tools including hydraulic or arbor press, dial indicator and straightening blocks. If facilities are not available locally, fork tubes may be returned to the factory for straightening.

### IMPORTANT

Repair fork tubes must be sent to the factory through an authorized Harley-Davidson dealer.

Never attempt to straighten a fork tube that has a sharp angle bend. It should be scrapped because the metal is stretched.

Before beginning the straightening operation, clean the fork tube. Locate bends with dial indicator. A fork tube is usually bent in two or three places, seldom only one. Place fork tube on straightening blocks. Correct bend in tube with an arbor or hydraulic press.

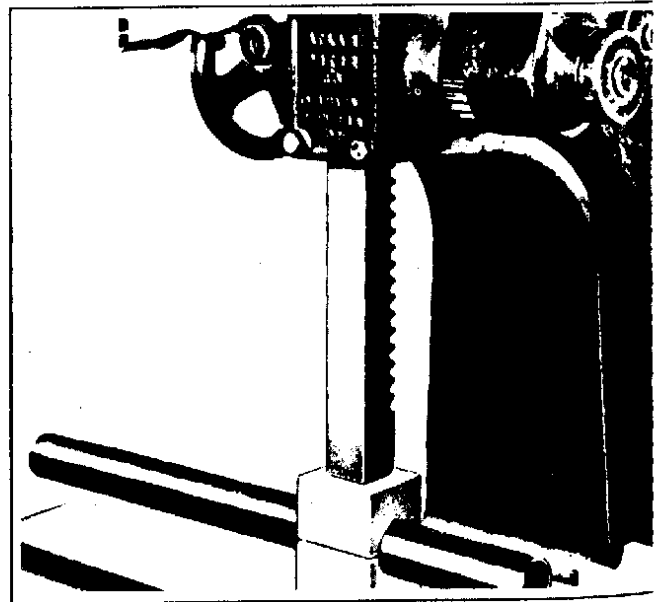

Figure 2F-11. Pressing Fork Tube Round

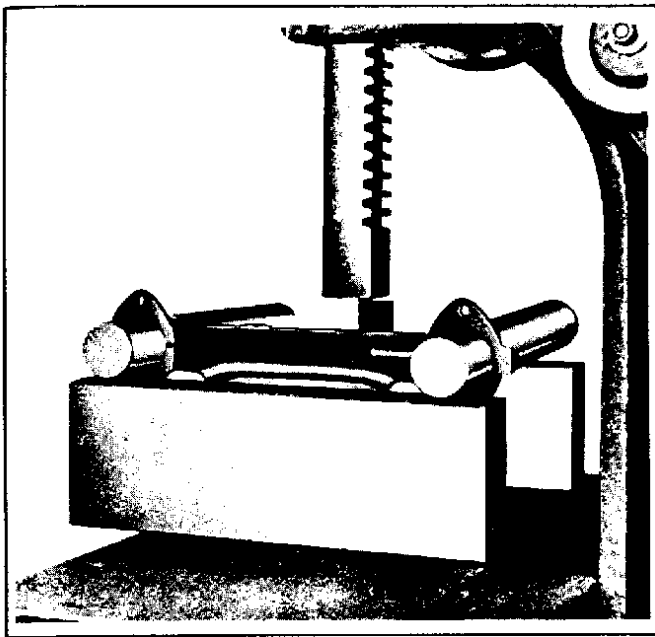

Figure 2F-12. Correcting Bracket Bow

Find the highest point out of round with a dial indicator (Fig. 2F-9) and mark with chalk. Press high point as shown in Fig. 2F-10. Repeat indicating and pressing operations until tube is within .003 in. to .004 in. of being straight.

Sometimes fork tubes are out of round, especially at the point it is clamped in the fork bracket. Place tube in straightening blocks and press until perfectly round as shown in Fig. 2F-11, checking with dial indicator and micrometer. Finally, check tube by inserting in new fork slider. Work tube up and down. If it does not bind, it is straight.

#### STRAIGHTENING FORK STEM AND BRACKET ASSEMBLY

Straightening a fork stem and bracket assembly requires a great deal of skill, experience and several tools and fixtures. Special tools necessary include Fork Tube Straightening blocks, Part No. 96246-50, four blocks are needed; Bending Bar, Part No. 96806-40; Fork Stem and Bracket Aligning Gauge, Part No. 96245-51. In addition, the following pieces of bar stock are needed: Two bars, 1-5/8 in. diameter, about 12 in. long; two bars 1 in. x 4 in. x 12 in. (approximately); assorted pieces of rectangular bar stock to use in transmitting arbor press pressure to unit to be straightened.

If facilities are not available locally, fork stem and bracket assembly may be sent to factory for straightening providing it is not badly bent or broken.

#### NOTE

Repair fork stem and bracket assemblies must be sent to factory through authorized Harley-Davidson dealers.

To straighten stem and bracket, proceed as follows: Insert the two 1-5/8 in. x 12 in. bars in fork bracket

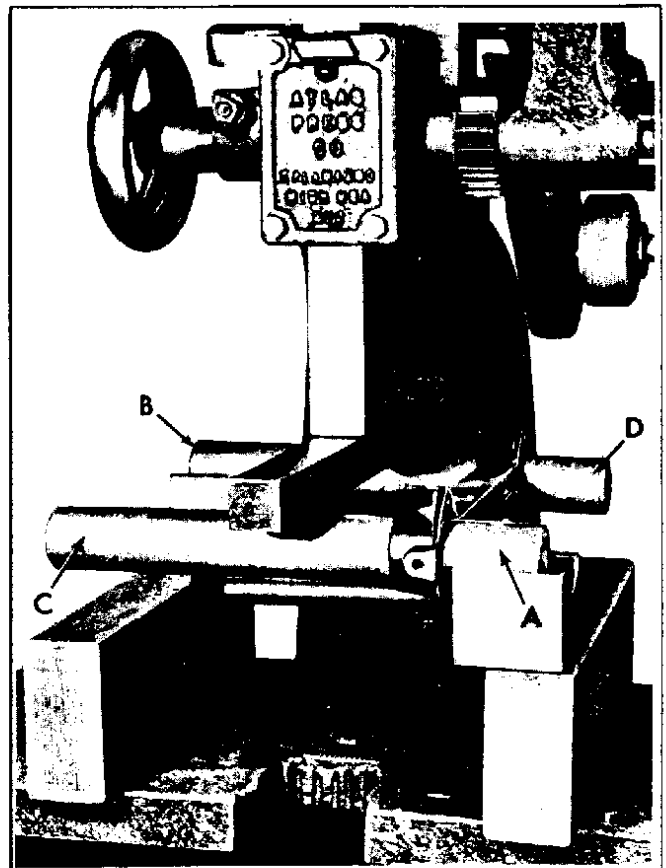

Figure 2F-13. Straightening Two Twisted Legs

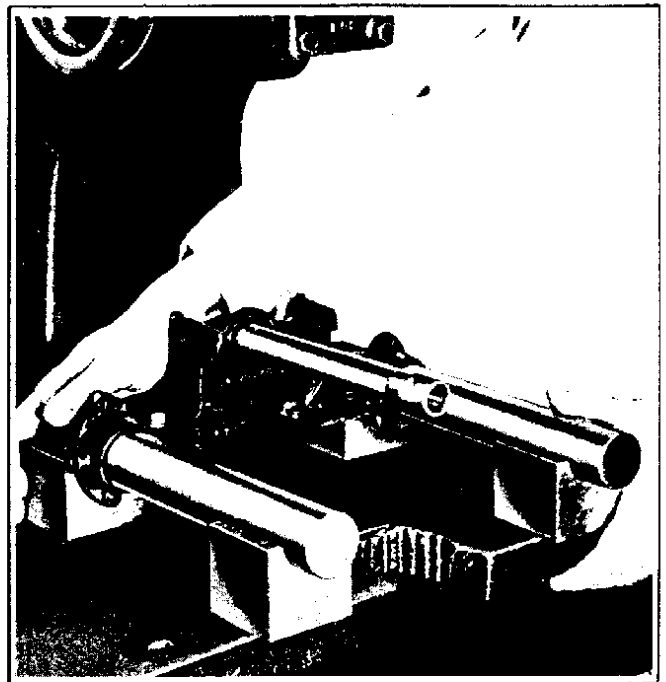

Figure 2F-14. Checking Bracket Alignment

and secure with two clamping studs. Sometimes the bracket is so badly bent that the bars cannot be inserted. In this case, press the bars into place with an arbor press, then press on the front edge of bracket to correct the "bow" distortion as shown in

Fig. 2F-12. Repeat pressing operation along edge until bars are loose in bracket.

A bracket assembly is usually out of alignment along the horizontal centerline, with one or both legs bent.

#### NOTE

Reference to vertical and horizontal centerlines applies to bracket and fork stem as positioned on arbor press (see Fig. 2F-12).

If both legs are twisted, place bracket assembly on arbor press as shown in Fig. 2F-13 with blocks placed under two low legs only (A and B). With press block placed across bracket and bar assembly, press until high legs (C and D) are in alignment.

If one leg is bent, place bracket and bar assembly on three straightening blocks, two blocks under straight leg and one block under low end of other leg. Place press block diagonally across bracket assembly to high leg until high leg is forced down and into alignment with the other three leg ends.

Place the fork stem and bracket assembly on the four straightening blocks located on the surface plate (see Fig. 2F-14). If the legs rest squarely on straightening blocks, the bracket assembly is correctly trued on a horizontal plane. If bracket is not true, press again, checking alignment after each operation.

Use a square to check if bracket assembly is bent, distorted or out of parallel on a horizontal plane as shown in Fig. 2F-15. Place bracket and bar assembly in a heavy vise and straighten using the Bending Bar.

Check fork stem alignment with Fork Stem and Bracket Aligning Gauge as shown in Fig. 2F-16. Use Bending Bar to bring stem into position. Recheck the fork completely.

#### ASSEMBLING FRONT FORK (GLIDE NON-ADJUSTABLE) (Fig. 2F-3)

Replace upper oil seal (23) and felt washer (22) in top of fork slider. Wash chips and oil from fork slider and position new oil seal in counterbore. Drive oil seal into counterbore and against seat with driver and mallet as shown in Fig. 2F-17. Drive with light blows and stop immediately when seal has bottomed.

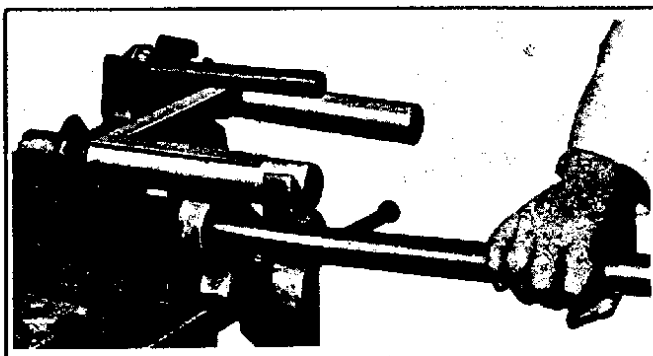

Figure 2F-15. Bending Bracket Legs Parallel

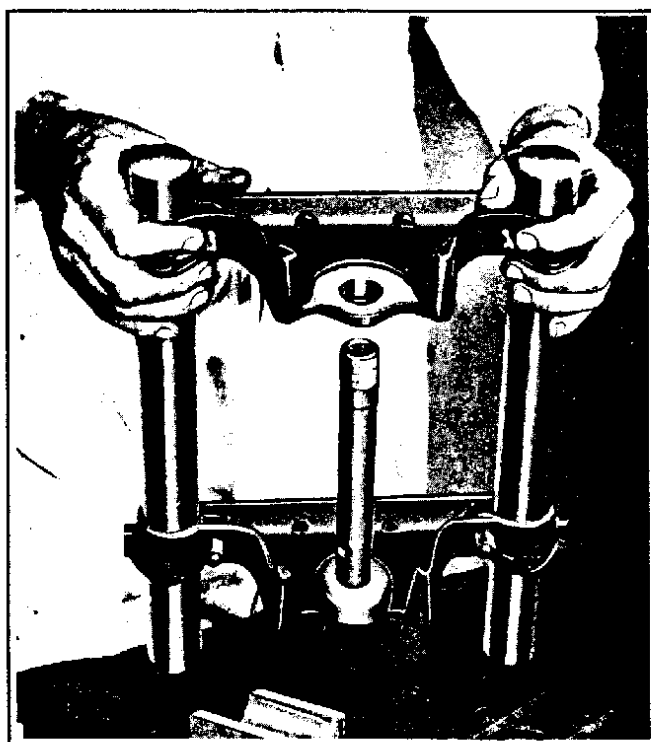

Figure 2F-16. Checking Stem Alignment with Gauge

Insert spring ring washer (21) and spring ring (20). Position spring ring so its gap is directly over water drain hole in slider top.

Clamp a length of about 1 in. steel rod upright in a vise so that 13-1/2 in. extends above top of jaws. Assemble damper valve (19) with gasket (18), lower bushing (17) and lower bushing gasket (16). Make sure all of old gasket is removed before installing new part. Invert slider tube over length of rod in vise and drop damper valve assembly in place. Install snap ring (15) in notch provided in bottom of slider tube. Check clearance between snap ring and lower bushing. If clearance exceeds .004 in., remove snap ring, gasket and lower bushing and insert additional shims to bring to a maximum of .004 in. clearance.

Lubricate outside of slider tube with fork oil and slip slider assembly down over slider tube. Turn lock nut (13) on damper valve stud extending out bottom of slider. Work slider to check for bind. If bind is present, release lock nut, rotate slider 180 degrees and reassemble. Fasten fork slider covers (10) to fork bracket (9), and slip fork bracket over slider tubes. Adjust so 5-1/16 in. of slider tube extends above top of fork bracket and temporarily tighten bracket clamping studs (8).

Pour 7 oz. of Harley-Davidson Front Fork Oil into each slider tube, insert fork springs (12) and turn in slider tube plugs (11).

Press lower head bearing guard (27) and greased lower head bearing (26) onto stem. Install stem in steering head on motorcycle. Grease and position upper head bearing (7). Turn on head bearing nut

## Notes

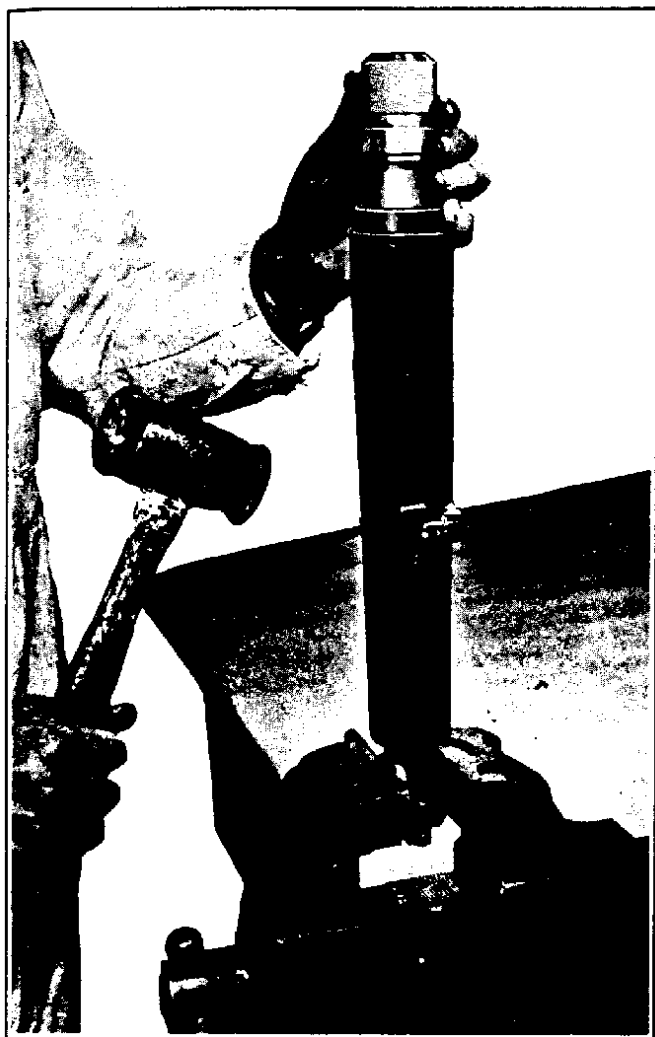

Figure 2F-17. Inserting New Oil Seal

(8), until there is noticeable drag in bearing when fork is turned - then loosen nut enough so fork turns freely. Install handlebar and fork bracket (5), bracket cover (4). Securely tighten slider tube plugs. Loosen bracket clamping studs (8) and rotate slider tubes so flats on slider tube plugs are to the sides of the fork assembly. They must be in this position to have the slider tube plugs function properly. Install fork stem nut and then securely tighten bracket clamping studs.

Slip plug oil seal (3) on upper bracket bolt (2) and screw into slider tube plug. Replace handlebar, etc. Reassemble motorcycle in reverse order of disassembly.

### ASSEMBLING FRONT FORK GLIDE ADJUSTABLE AND SERVI-CAR) (Fig. 2F-4)

Follow procedure described for non-adjustable front fork except for the following points:

1. Position slider tubes in bracket (21) so top of slider tube is exactly 5-1/16 in. above top of bracket, and flat surfaces on slider tube plugs are directly toward side of motorcycle with filler screw (23) toward rear of fork.



## BRAKES

### DISASSEMBLING FRONT BRAKE (Fig. 2G-2)

Remove wheel with brake drum from fork as described in 2C. Spring brake shoes out and away from side cover (23) at top to free shoes (2 and 4) and springs (1 and 3) from pivot stud (8) and cam lever (18).

Remove cotter pin (16), cam lever washer (17) from cam lever stud (20). Disconnect control coil ferrule by loosening clamp nut (10) and depressing brake hand lever. Slip cam lever assembly off stud. Make complete disassembly in order shown.

### INSPECTION AND SERVICING (Fig. 2G-2)

If linings are worn down to rivet heads, impregnated with grease as a result of over-greasing wheel hubs, cracked or ridged badly, they must be replaced. When relining a shoe, start at one end and work to the other to make linings bear tightly against shoe.

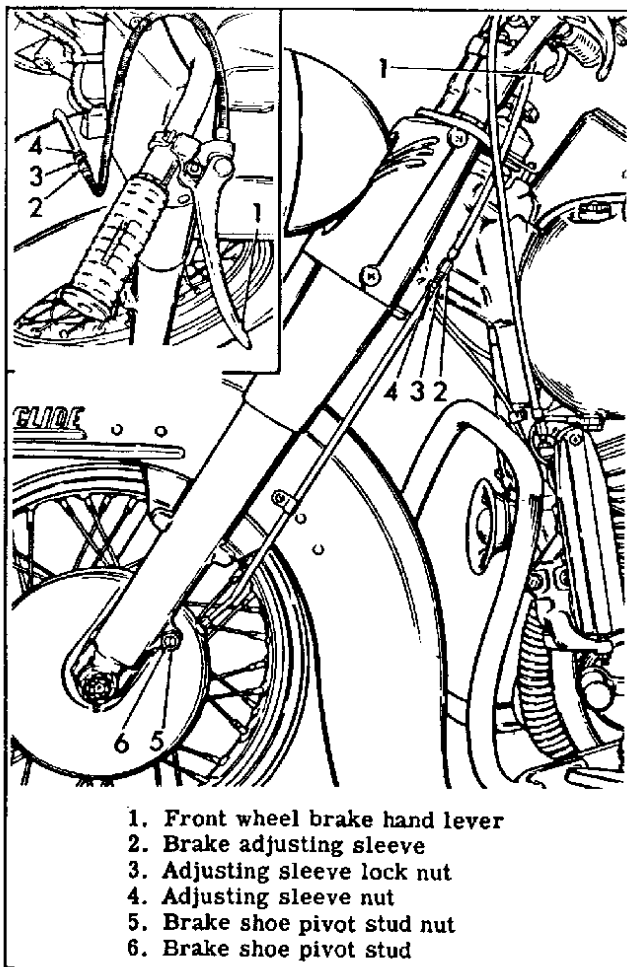

Figure 2G-1. Adjusting Front Brake

If a riveting machine is not available, set rivets with hand tools and bevel lining ends.

Examine drums for ridging and scoring. Surface must be reasonably smooth and flat. If ridged, turn down drums to clean up. Wash cam lever and cam lever stud and check fit. If play exists, force out cam lever bushing (24) and install new part.

### ASSEMBLING FRONT WHEEL BRAKE (Fig. 2G-2)

Assemble in reverse order of disassembly except, for ease of assembly, connect two shoes with top return spring (3). Position unit on pivot stud (8) and cam lever (18). Insert lower spring (1). Spring hooks must be in shoe spacer notch nearest side cover. Reassemble wheel.

### ADJUSTING FRONT BRAKE CABLE (Fig. 2G-1)

Front brake cable may be adjusted as follows:

Loosen adjusting sleeve lock nut (3) and turn adjusting sleeve nut (4) to obtain desired amount of hand lever (1) free movement; clockwise for less movement and counterclockwise for more movement. About 3/16 in. of brake cable movement should be free, or about 1/4 of the full lever movement. Tighten adjusting sleeve lock nut.

### ADJUSTING FRONT BRAKE SHOES

Raise front wheel off ground so it may be rotated. Loosen brake shoe pivot stud nut (5, Fig. 2G-1) and loosen axle sleeve nut. Apply brake. With brake pressure applied, tighten axle sleeve nut and pivot stud nut. This procedure centers shoes against drum so full lining length contacts drum on brake application.

### Memoranda

---



---



---



---



---



---



---



---



---



---

1949 & LATER

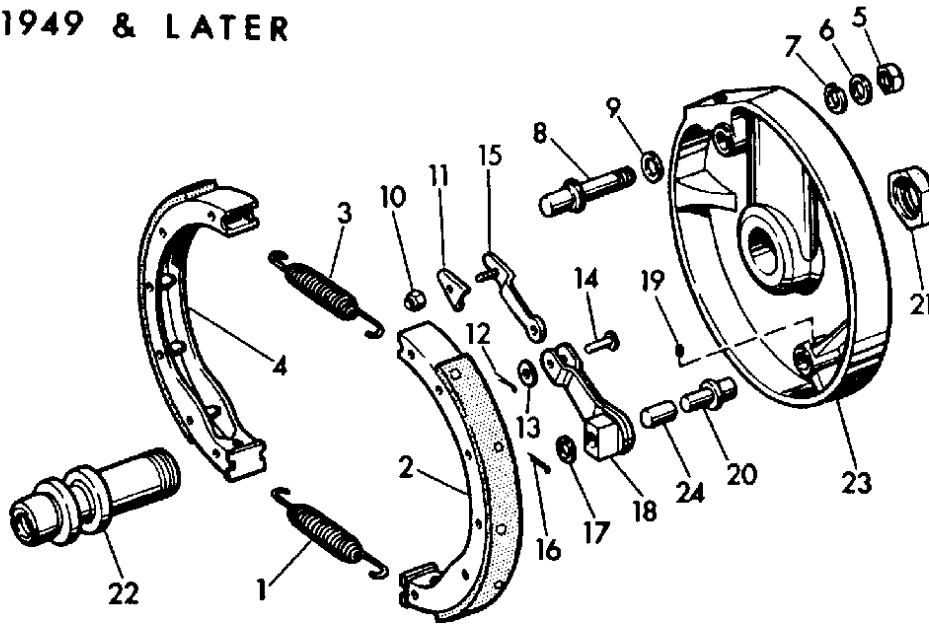

- |                                       |                          |                       |
|---------------------------------------|--------------------------|-----------------------|
| 1. Brake shoe spring (2)              | 9. Pivot stud washer     | 17. Cam lever washer  |
| 2. Brake shoe and lining (2)          | 10. Clevis clamp nut     | 18. Cam lever         |
| 3. Brake shoe spring (see item 1)     | 11. Cable clevis clamp   | 19. Set screw         |
| 4. Brake shoe and lining (see item 2) | 12. Cotter pin           | 20. Cam lever stud    |
| 5. Brake shoe pivot stud nut          | 13. Flat washer          | 21. Axle sleeve nut   |
| 6. Pivot stud flat washer             | 14. Cam lever clevis pin | 22. Front axle sleeve |
| 7. Pivot stud lock washer             | 15. Cable clevis         | 23. Brake side cover  |
| 8. Pivot stud                         | 16. Cotter pin           | 24. Cam lever bushing |

Figure following name of part indicates quantity necessary for one complete assembly.

NAME

Brake Shoe and Lining (same as Item 26)  
 Brake Shackle Bushing (same as Item 4)  
 Brake Shackle

Brake Shackle Fork Stud Washer  
 Lock Washer  
 Brake Shackle Stud Nut  
 Brake Shoe Pivot Stud  
 Brake Shoe Pivot Stud Plate  
 Lock Washer  
 Brake Shoe Pivot Stud Nut  
 Front Axle Sleeve  
 Brake Side Cover Bushing  
 Brake Side Hub Washer (cork)  
 Brake Side Plate Spring  
 Brake Side Hub Washer  
 Axle Sleeve Nut  
 Brake Operating Shaft  
 Brake Operating Shaft Spring Washer  
 Brake Shoe Spring (same as Item 21)

Brake Operating Lever (use inner clevis pin hole for solo service,  
 outer clevis pin hole for sidecar service)  
 Brake Operating Shaft Washer  
 Lock Washer  
 Brake Operating Shaft Nut  
 Brake Side Cover

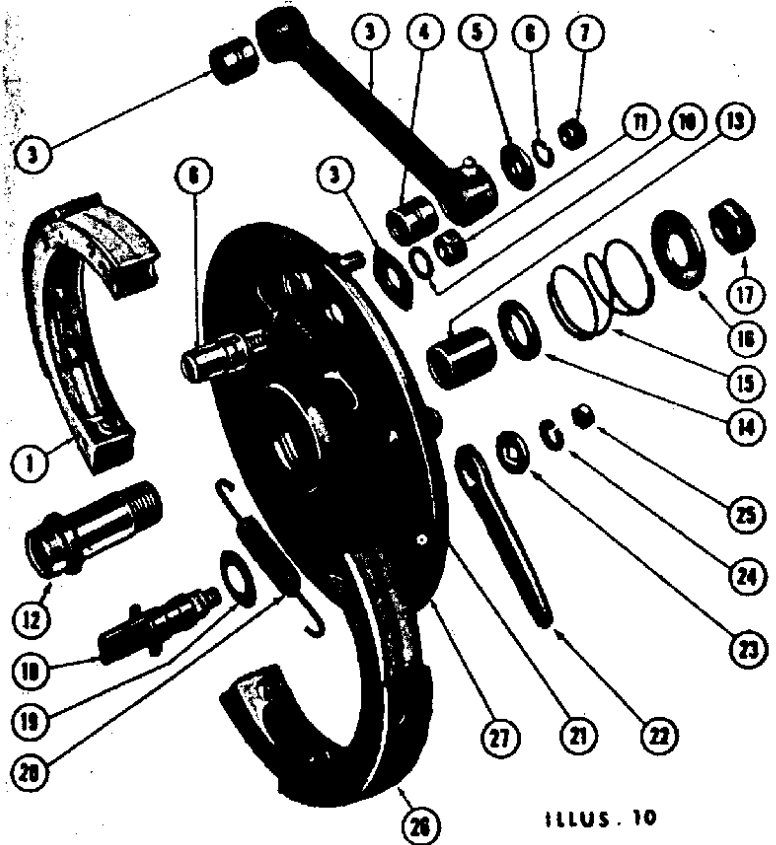

ILLUS. 10

1948

FRONT WHEEL BRAKE ASSEMBLY

# REAR WHEEL BRAKE ASSEMBLY

(Item Numbers Refer to Illus. 11)

ITEM	NUMBER USED	NAME
1	1	Brake Shoe and Lining (rear shoe)
2	1	Cotter Pin
3	1	Brake Shoe Cup (outside)
4	1	Brake Shoe Cup (inside)
5	1	Brake Shoe Pivot Stud
6	1	Brake Side Cover
7	1	Brake Shoe Pivot Stud Plate
8	1	Lock Washer
9	1	Brake Shoe Pivot Stud Nut
10	1	Rear Axle Sleeve
11	1	Rear Axle Sleeve Collar
12	1	Rear Axle Sleeve Nut
13	1	Brake Operating Shaft
14	1	Brake Operating Shaft Spring Washer
15	1	Brake Operating Shaft Bushing
16	1	Brake Shoe Spring
17	1	Brake Operating Lever
18	1	Lock Washer
19	1	Brake Operating Shaft Nut
20	1	Brake Shoe and Lining (front shoe)

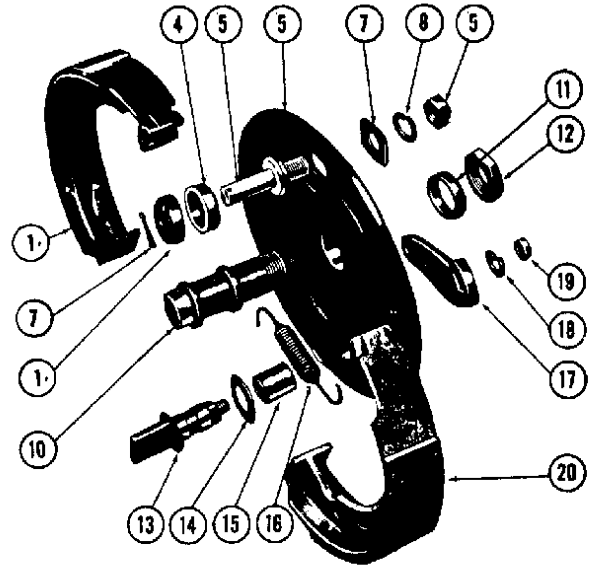

ILLUS. 11  
REAR WHEEL BRAKE DISASSEMBLED

## Harley Mechanical Brake Parts

- B1 Brake pedal
- B2 Brake pedal backing plate, with washers and nuts
- B3 Front clevis  
Clevis pin (B3-A)
- B4 Front brake rod
- B5 Cross shaft with washers and nuts
- B6 Two-hole arm, right side
- B7 One-hole arm, left side
- B8 Rear brake rod, with nut, washer and key

- B9 Rear clevis  
Clevis pin (B3-A)
- B10 Rear brake arm
- B11 Brake cam, nut and washer
- B12 Rear axle spacer
- B13 Rear axle, nut
- B14 Axle stub spacer
- B15 Backing plate sleeve
- B16 Backing plate sleeve nut
- B17 Pivot stud and cups, nut, washer and pin
- B18 Brake lining and rivets
- B19 Brake springs

- B20 Lockwasher
- B21 Chromed wheel lug bolt
- B22 Sprocket kit, includes dust shield and rivets
- B23 Brake drum
- B24 Brake drum and sprocket assembled,

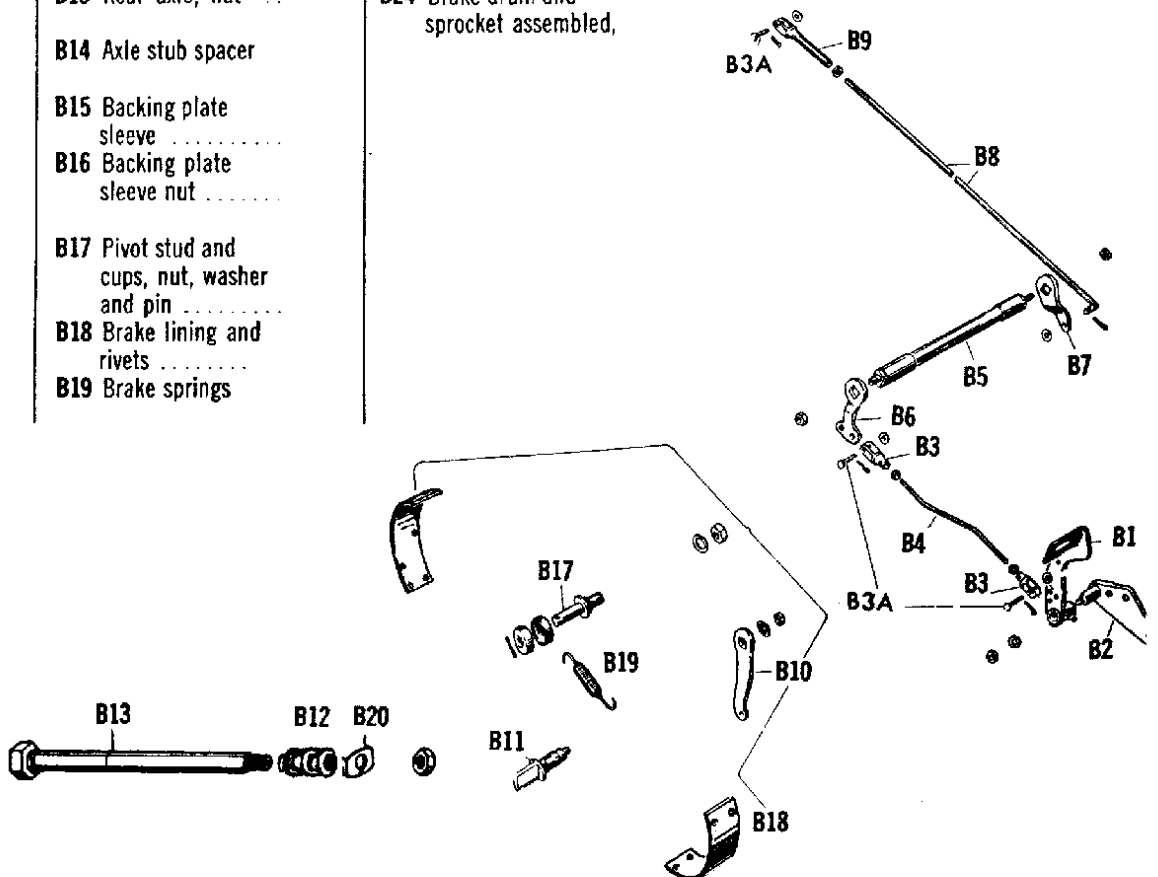
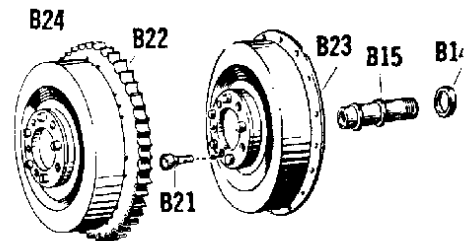

1948

**ADJUSTING BRAKES****Adjusting Front Wheel Brake**

Loosen adjusting sleeve lock nut and turn adjusting sleeve as necessary to attain correct free movement of hand lever. After correct hand lever adjustment is made, tighten adjusting sleeve lock nut.

Properly adjusted, hand lever will move freely about one-quarter of its full movement before brake starts to take effect. Adjusted tighter brake may drag.

Keep brake control wire well oiled for easy operation.

**Adjusting Rear Wheel Brake**

Loosen clevis lock nut on brake rod. Remove clevis pin from end of rear brake rod clevis and turn clevis as necessary to attain correct adjust-

ment.

Correctly adjusted, brake will not take effect until pedal is pushed down about an inch. Brake should take full effect at least an inch before pedal bottoms. Turn rear wheel to make sure brake is not too tight and dragging.

Note: If motorcycle is equipped with sidecar, see "Adjusting Sidecar Wheel Brake," before adjusting rear wheel brake.

**Adjusting Sidecar Wheel Brake**

Disconnect sidecar brake rod (short rod) from brake shaft lever. Adjust rear wheel brake, see "Adjusting Rear Wheel Brake." After rear wheel brake has been correctly adjusted, adjust length of sidecar brake rod so when footpedal is operated, the rear brake starts to take effect slightly before sidecar wheel brake.

**SERVICING BRAKES**

If a correctly adjusted brake does not function normally, new brake shoe linings and/or brake drum are usually needed, however, any worn or damaged parts that affect operation of brake must be renewed.

Remove wheel (see "Wheels, Hubs and Tires,"

To remove rear wheel brake shoes: (To identify items, refer to Illus. 11). Remove cotter pin (2) and brake shoe cup (3) from pivot stud (5). Pry brake shoes off pivot stud without removing shoe spring (16).

To remove front or sidecar wheel brake shoes: (To identify items, refer to Illus. 10). Place the end of a large screwdriver or other suitable tool between the ends of brake shoes at pivot stud (8) and pry ends of shoes off pivot stud without removing shoe springs (20) and (21). Shoe ends are registered in a groove in pivot stud.

Note: Sidecar wheel brake shoes, brake shoe springs, brake operating shaft and pivot stud, and the manner of assembling these items are the same as applies to "Front Wheel Brake Assembly," Illus. 10 and 12.

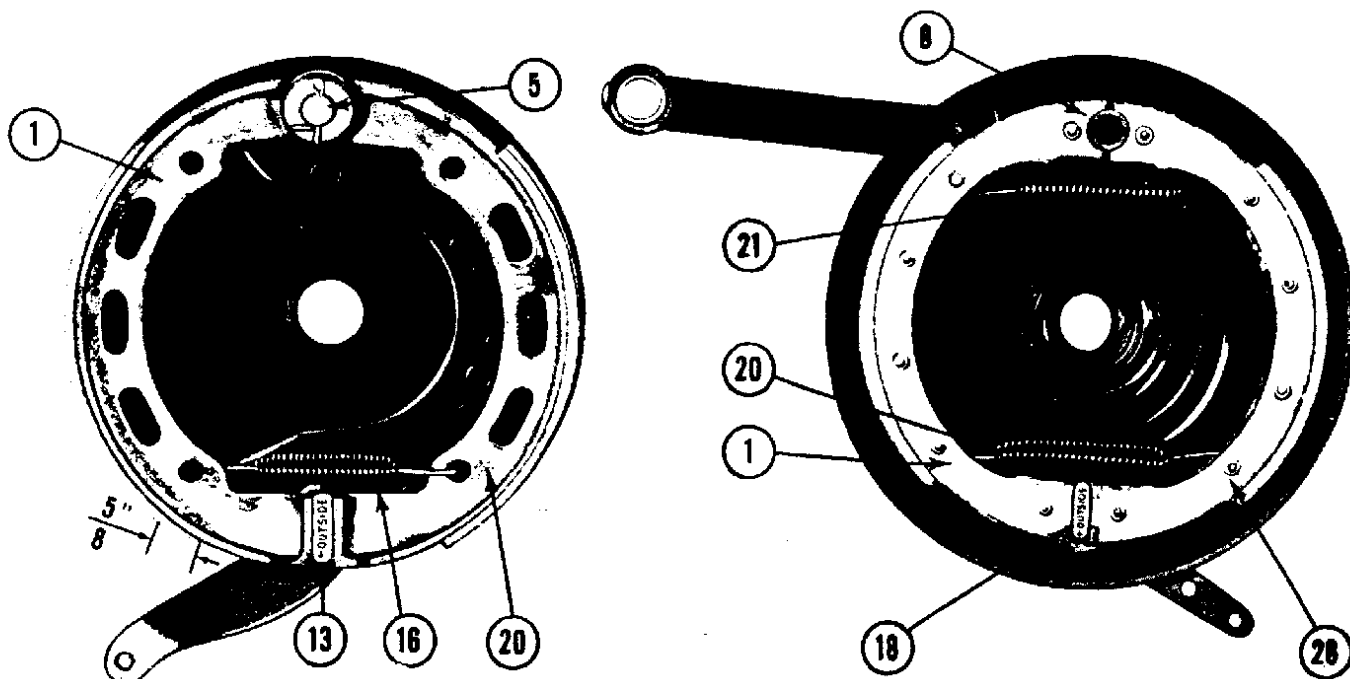

ILLUS. 12

FRONT AND REAR BRAKE ASSEMBLIES  
(To Identify Items Refer to Illus. 10 and 11)

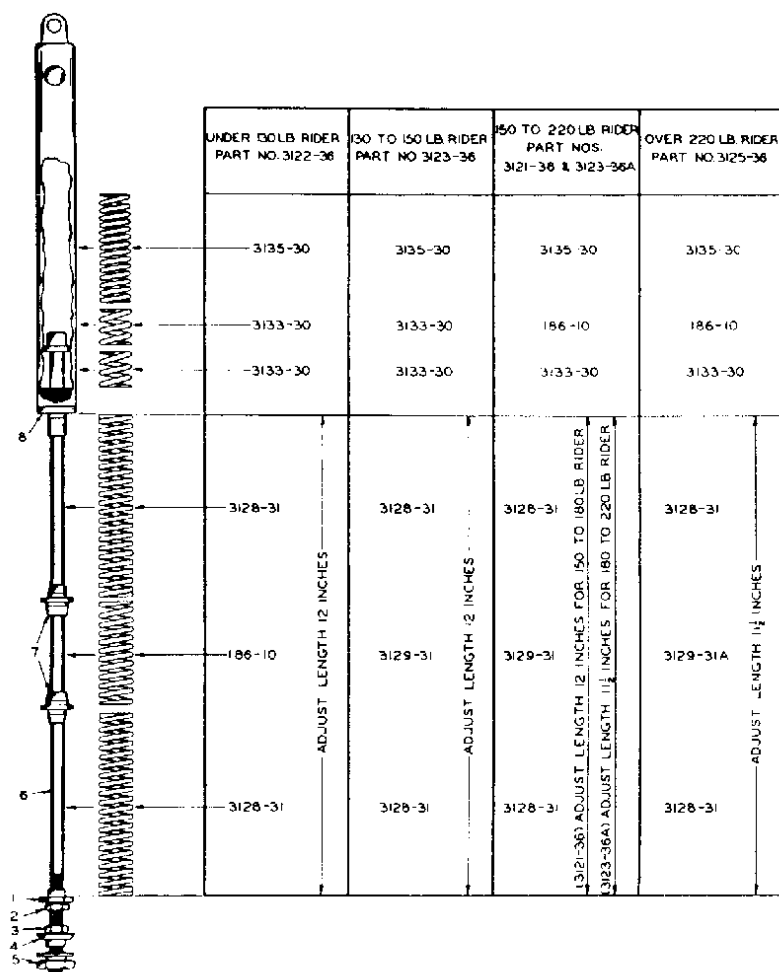

ILLUS. 20  
SPRING SADDLE POST ASSEMBLY  
Standard Assembly (150 to 180 lb. Rider) Part No. 3121-36.

## SERVICING SADDLE SPRING POST

(To Identify Items and Part Numbers, Refer to Illus. 20)

Spring combinations with part numbers that make up saddle spring post assemblies, Part Nos., 3122-36, 3123-36, 3121-36, 3123-36A, 3125-36, are listed.

New motorcycles are furnished with standard saddle spring post assembly unless other than standard is specified on order.

The illustration shows following parts of saddle spring post assembly:

1. Spring tension adjusting nut.
2. Adjusting nut lock nut.
3. Rod nut lock nut.
4. Rod nut.
5. Post clamp nut.
6. Saddle post rod.
7. Spring guide collars.
8. Plunger nut.

After raising saddle, remove saddle post clamp nut (5), which is located underneath frame at bottom end of post tube. Post assembly can then be pulled out.

To disassemble saddle spring post, remove nuts (1, 2, 3, and 4), cushion springs and collars (7). Remove nut (8) from plunger and then saddle post rod (6) and upper springs are free for removal. To re-

assemble, reverse operations of disassembly. To adjust cushion spring assembly (three lower springs), loosen lock nut (2) and turn adjusting nut (1) to right to increase spring tension; to left to decrease spring tension. If, however, considerable change in spring tension is required, a different set of springs to suit weight of rider will be required. Refer to Illus. 20 to determine spring combination needed.

Saddle spring post assemblies, Part Nos. 3121-36 and 3123-36A, use same spring combination but adjustment of cushion spring assemblies differs as shown in illustration.

When post assembly is inserted in frame tube, see that flat side machined on post rod nut (4) registers in flat side of hole in bottom of tube.

Ordinarily saddle spring post assembly will not need lubrication other than that given with grease gun at intervals given in Lubrication Chart. See "Lubrication Chart," Page 9.

If, however, spring combination is changed, any springs replaced, or springs and other parts cleaned, initial lubrication should be given by applying a liberal amount of Harley-Davidson grade "A" grease to springs and other moving parts.

# ENGINE

## GENERAL

### ENGINE SPECIFICATIONS

#### VALVES (3B)

Fit in guide (EX) . . . . .	.004 - .006 in.
Fit in guide (IN) . . . . .	.002 - .004 in.
Spring (FL)	
(Outer) . . . . .	55 - 65 lbs. at 1-13/32 in. (closed)
	110 - 120 lbs. at 1-1/16 in. (open)
Free length . . . . .	1-13/16 in.
(Inner) . . . . .	25 - 35 lbs. at 1-1/4 in. (closed)
	70 - 80 lbs. at 29/32 in. (open)
Free length . . . . .	1-15/32 in.
Spring (FLH)	
(Outer) . . . . .	105 - 115 lbs. at 1-3/8 in. (closed)
	180 - 190 lbs. at 1 in. (open)
Free length . . . . .	1-31/32 in.
(Inner) . . . . .	25 - 35 lbs. at 1-3/16 in. (closed)
	70 - 80 lbs. at 51/64 in. (open)
Free length . . . . .	1-23/64 in.

Tappet adjustment . . . . Hydraulic tappet unit compressed 1/8 in. from fully extended position.

#### ROCKER ARM (3B)

Fit in bushing . . . . .	.001 - .002 in. loose
End clearance . . . . .	.004 - .012 in.

#### PISTON (3C)

Fit in cylinder . . . . .	.001 - .002 in. loose
Ring gap (compression) . . . . .	.010 - .020 in.
Ring side clearance . . . . .	.004 - .005 in.
Oil ring (Rail Type)	
Gap . . . . .	.015 - .030 in.
Side clearance . . . . .	.0035 - .008 in.
Oil ring overlap (U-Flex) . . . . .	11/32 in.
Piston pin fit . . . . .	Light hand press at 70° F.

#### CONNECTING ROD (3C)

Piston pin fit . . . . .	.0008 - .0012 in. loose
End play between flywheels . . . . .	.006 - .010 in.
Fit on crankpin . . . . .	.001 - .0015 in. loose

#### OIL PUMP PRESSURE

(3D) . . . . .	(20 MPH) 25 lbs./sq. in.
	(30 MPH) 35 lbs./sq. in.
	(60 MPH) 35 lbs./sq. in.
	(90 MPH) 35 lbs./sq. in.

#### IGNITION TIMING (3D)

Breaker point setting . . . . .	.022 in. gap
Points to open . . . . .	34° - 36° BTC
	(7/16 in. before Piston T.C.)

#### TAPPETS (3D)

Guide fit . . . . .	.002 tight - .002 loose
Fit in guide . . . . .	.001 - .002 in. loose
Roller fit . . . . .	.0005 - .001 in.
Roller end clearance . . . . .	.008 - .010 in.

#### GEARCASE (3D)

Timer gear end play . . . . .	.003 - .007 in.
Idler gear end play . . . . .	.003 - .007 in.
Breather gear end play . . . . .	.001 - .005 in.
Cam gear shaft in bushing . . . . .	.001 - .0015 in.
Cam gear end play . . . . .	.001 - .005 in.
Intermediate and idler gear	
(on shafts) . . . . .	.001 - .0015 in.
Oil pump drive shaft	
(crankcase bushing) . . . . .	.0008 - .0012 in.

#### FLYWHEEL ASSEMBLY (3E)

Runout (flywheels) . . . . .	.003 in. maximum at rim
Runout (mainshafts) . . . . .	.001 in. maximum

#### SPROCKET SHAFT BEARING (3E)

Cup fit in crankcase . . . . .	.0015 - .0035 in. press
Cone fit on shaft . . . . .	.0002 - .0015 in. press
End play . . . . .	.0001 - .010 in.

#### PINION SHAFT BEARINGS (3E)

Roller bearing fit . . . . .	.0005 - .001 in. loose
Cover bushing fit . . . . .	.0005 - .0012 in. loose

### ENGINE DESCRIPTION

The Glide engine is a two-cylinder, four-cycle, air cooled, overhead-valve, V-type engine with 74<sup>1</sup>/<sub>2</sub> cu. in. displacement. It has three major component assemblies: cylinder, crankcase and gearcase.

Cylinder assemblies include cylinder head, valves, rocker arms and piston. Cylinders mount on the engine crankcase in a 45 degree "V," with both connecting rods connected to a single crank pin.

The reciprocating, linear motion of the piston in the cylinder is converted to circular motion in the crankcase. The built-up crankshaft consists of an off-center crank pin interposed between two counter-weighted flywheels which rotate on two end shafts (pinion and sprocket shafts) supported by anti-friction roller bearings. The lower end of the rear cyl-

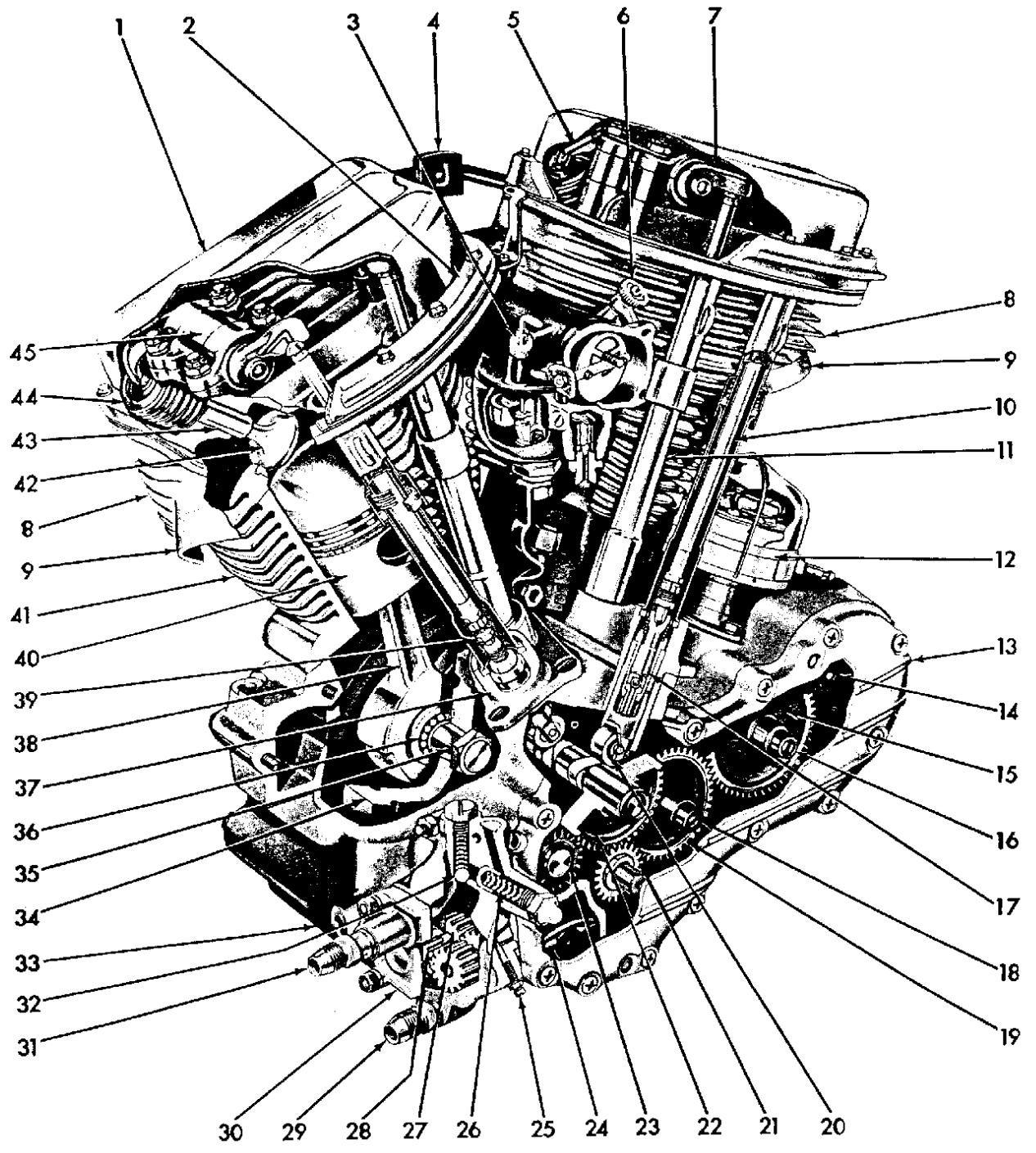

3a-1



## LEGEND FOR FIGURE 3A-1

- |                                     |                                  |                                   |
|-------------------------------------|----------------------------------|-----------------------------------|
| 1. Rocker arm cover                 | 15. Idler gear                   | 31. Oil feed nipple               |
| 2. Cover reinforcing ring           | 16. Idler gear spacer            | 32. Check valve                   |
| 3. Carburetor high-speed adjustment | 17. Hydraulic lifter             | 33. Crankcase                     |
| 4. Engine mounting bracket          | 18. Intermediate gear spacer     | 34. Flywheel                      |
| 5. Intake valve oiler               | 19. Intermediate gear            | 35. Crankpin                      |
| 6. Carburetor low-speed adjustment  | 20. Tappet and roller assembly   | 36. Connecting rod roller bearing |
| 7. Rocker arm                       | 21. Pinion gear                  | 37. Tappet guide                  |
| 8. Cylinder head                    | 22. Cam gear                     | 38. Connecting rod                |
| 9. Exhaust port                     | 23. Breather gear                | 39. Tappet adjustment             |
| 10. Push rod                        | 24. Breather screen              | 40. Piston                        |
| 11. Push rod cover                  | 25. Chain oiler adjustment screw | 41. Cylinder                      |
| 12. Circuit breaker (timer)         | 26. By-pass valve                | 42. Exhaust valve                 |
| 13. Gearcase                        | 27. Oil feed pump drive gears    | 43. Exhaust valve guide           |
| 14. Generator drive gear            | 28. Oil scavenger drive gears    | 44. Valve spring                  |
|                                     | 29. Oil return nipple            | 45. Rocker arm bearing            |
|                                     | 30. Oil pump                     |                                   |

inder connecting rod is forked to fit around the single-end front cylinder connecting rod, allowing a single connecting rod-crankpin connection to the flywheel.

Flywheel rotation is clockwise (viewing engine from right side). Using the front cylinder firing position as a starting point, the rear cylinder fires at 315 degrees rotation (360 degrees minus the 45 degrees between cylinders). The front fires in an additional 405 degrees (360 degrees plus the 45 degrees between cylinders), completing the 720 degrees of flywheel rotation necessary for the four piston strokes.

The gearcase is located on the right side of the crankcase and houses a gear train which operates and times the valves, ignition and crankcase breather. The generator is also driven from the gear train. The rotary crankcase breather valve is located between crankcase and gearcase compartments and functions to relieve crankcase pressure caused by downstroke of pistons, and controls the flow of oil in the lubrication system.

A single cam shaft with four cam lobes is gear driven. The engine valves are opened and closed through the mechanical linkage of tappets, push rods and rocker arms. Tappets serve to transmit the cam action to the valve linkage. Hydraulic lifters installed in the tappets automatically compensate for heat expansion to maintain a no-lash fit of parts. Valve and breather timing are obtained by meshing gearcase gears with timing marks aligned.

Ignition spark is produced by operation of circuit breaker, ignition coil and spark plugs. The breaking of a single set of breaker points by a double-lobe cam on the timer shaft determines the spark timing. The narrow lobe times the front cylinder. The wide lobe times the rear cylinder. Both spark plugs fire on each breaker point opening (twice per complete cycle of 720 degrees flywheel rotation since cam shaft operates at 1/2 engine speed). The valves are timed to produce combustion conditions in only one

cylinder at a time so the spark in the other cylinder occurs ineffectually during its exhaust stroke.

Most other engine components function similar to usual internal combustion engine design. For further description of part function, see pertinent manual sections.

## LUBRICATION

The engine is lubricated by a pressure system circulating oil from the tank through the moving parts and back to tank. For adequate lubrication the tank must contain an ample supply of clean oil at all times.

Oil consumption varies from 250 to 500 miles per quart depending on the nature of service, solo or sidecar, fast or moderate driving, and how well the engine is kept tuned. If mileage is not within this range, see following engine overhaul section.

Remove tank cap and check oil supply at not more than 300 miles after each complete refill. If level is down near "Refill" mark on gauge rod, add oil. When level is down to "Refill" mark, add two quarts. Engine will run cooler and usage will be less with oil level well up in tank.

The oil tank capacity is one gallon. The tank is full when the oil level is about one inch from top. Do not fill above this level. The tank needs some air space. Tighten the cap securely to prevent leakage.

Change oil in new engine after first 750 miles, service at about 2,000 mile intervals thereafter. Completely drain oil tank of used oil and refill with fresh oil. If service is extremely hard, hot, on dusty roads or in competition, drain and refill at shorter intervals. Draining should be done while oil is hot. It is not necessary to drain the crankcase for it does not accumulate more than about 5 oz. of oil at any time. At the time of the first 750 mile oil change, and along with at least every second oil change thereafter, thoroughly flush and clean out tank with kerosene to remove any sediment and sludge that may have accumulated.

## WINTER LUBRICATION

Combustion in any engine generates water vapor. When starting and warming up in cold weather, especially in freezing or cold weather, the vapor that gets into the crankcase condenses to water before the crankcase is hot enough to exhaust the vapor through the outside breather. If engine is run often enough to get the crankcase thoroughly warmed up, most of this water is again vaporized and blown out through the breather. A moderately driven engine, making short runs and seldom allowed to thoroughly warm up, will accumulate increasing amounts of water in the oil tank. This water will, in freezing weather, become slush or ice and if allowed to accumulate, will block oil lines and damage the engine. Water mixed with oil for some time forms sludge that is harmful to the engine and causes rapid wear of various working parts. In winter the oil should be changed more often than in normal weather. Any engine used for short runs, particularly in commercial service, must have oil changed frequently and tank thoroughly flushed to remove water and sludge, before new oil is put in tank. The farther below freezing the temperature drops, the shorter the oil change interval should be.

## CHANGING OIL

Run engine until it is fully warm. Block motorcycle upright or tilted to right at a slight angle. Remove oil tank plug from bottom of tank at right rear corner. Allow all oil to drain. Replace plug. Pour a quart of kerosene into tank and agitate by rocking motorcycle from side to side. Remove plug and drain. Replace plug and fill with recommended grade oil as follows:

Use Harley-Davidson 105 (regular heavy) oil when predominating temperature is 75°F or above. Use Harley-Davidson 75 (medium heavy) oil when predominating temperature is 32°F to 75°F. Use Harley-Davidson 58 (light) oil when predominating temperature is 32°F or below.

Old oil may be removed using a suction gun through filler hole and flushed by squirting kerosene into tank from a gun.

## OIL PRESSURE SIGNAL LIGHT

The oil signal light, located above ignition switch on instrument panel, indicates oil circulation.

If the oil signal light fails to go off at speeds above idling, it is usually due to low or a diluted oil supply. In freezing weather the oil feed pipe may clog with ice and sludge, preventing circulation of oil. A grounded oil signal switch wire, faulty signal switch, or trouble with oil pump will also cause the light to stay on. If the oil signal light fails to go off, always check the oil supply first. Then, if oil supply is normal, look inside the oil tank to determine if oil returns to the tank from the oil return pipe outlet located at front of oil tank near filler hole when the engine is running. If it is returning to the tank there is some circulation, and engine may be run a short dis-

tance if necessary. If no oil returns, shut off engine until trouble is located and corrected.

## OPERATING OIL PRESSURE

Operating oil pressure may be checked as follows:

Fill oil tank with Harley-Davidson 75 oil. Disconnect oil pressure switch wire at top of switch and remove switch. Install Oil Pressure Gauge, Part No. 96921-52. Attach gauge bracket to motorcycle and road run or simulate road running until engine is completely warmed. A full operating temperature is essential for accurate gauging. Pressure should be 25 to 28 pounds per square inch at 20 mph. At 30 mph. and over, pressure should be steady at 35 to 38 pounds.

## OIL FILTER (STANDARD, EXTERNAL)

If motorcycle is equipped with an oil filter, thoroughly wash the filter element in clean gasoline or solvent at least once every 2,000 miles when the engine oil is changed. Blow out element with compressed air before installing.

To remove the filter element, take off acorn nut, fiber washer and cup. Remove element retaining nuts and metal element retainer. Then pull element off stud. If upper metal retainer (retainer with five holes in it for oil passage) comes off with the filter element, make sure that it is reinstalled as the upper retainer when replacing the element.

Replace filter element every 5,000 miles.

## OIL FILTER (SPECIAL)

All models specially equipped with large, 51 ampere hour battery are fitted with an external oil tank located to right side of battery case, under the seat. The tank is equipped with a large mouth filler opening and a screw cover. As optional equipment, this tank may be fitted with an internal oil filter (see Fig. 3A-2).

Wash filter element (3) in clean gasoline or solvent at 2,000 mile intervals, renew at 5,000 mile intervals. To service filter element, remove cap from oil tank, remove retaining spring (1) and washer (2) and pull out filter. Make certain "O" ring is positioned against filter cup flange (6) when filter is installed in tank.

**SERVICING OIL TANK CAP AND FILLER OPENING.** To disassemble, follow order shown in Fig. 3A-2. Assembly is reverse order of disassembly. Clean and inspect all parts. Replace any that are worn or damaged.

If oil leak should occur between the tank cap and the filler opening, with cap and gasket in serviceable condition, check the lip of the filler opening. A cap

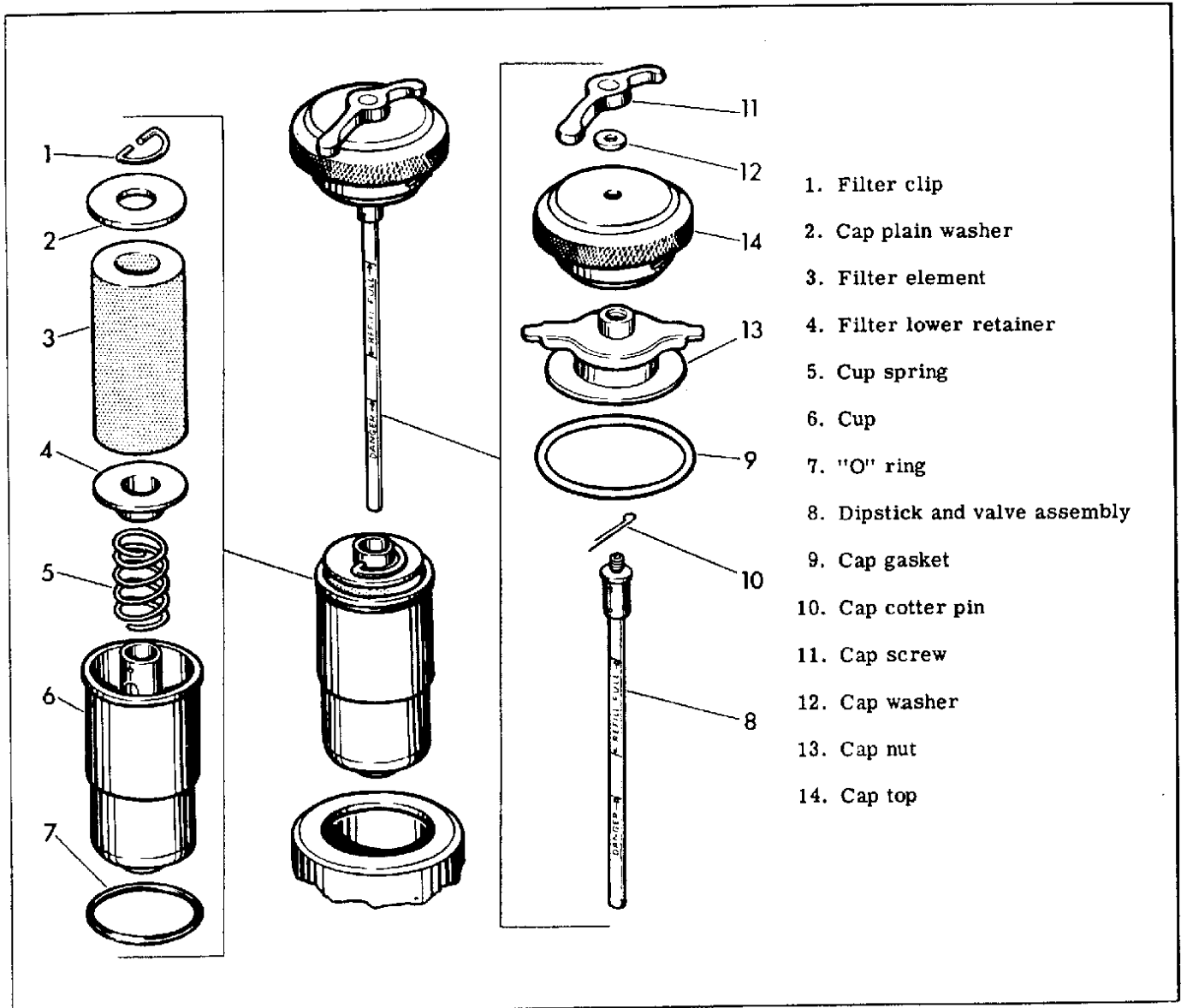

Figure 3A-2. Oil Tank Filter - Exploded View

drawn too tight will bend the lip of the filler opening resulting in an imperfect seal between gasket and lip.

Drain oil from tank. Using a mallet as a driver and a block of wood as a cushion, bend the lip down until flush with sealing surface of tank cap. Remove nicks and rough spots with emery cloth. Flush tank before refilling.

#### PRESSURE OIL SYSTEM (Fig. 3A-3)

A. Feed section of oil pump.

B. Check valve.

C. Maximum oil pressure regulating valve.

D. Front chain oiler adjusting screw.

E. Pinion gear shaft through which oil is forced to connecting rod lower bearings, from which it

splashes to cylinder walls, pistons, main bearings, etc.

F. Oil screen.

G. Dripper.

H. Push rod.

→ Feed oil from tank to engine. Oil is forced through passages as indicated to connecting rod lower bearings, and through oil screen (see inset) and passages in crankcase, cylinder and head walls to tappets, hydraulic lifters, rocker arms and push rods.

⇨ By-Pass oil. Surplus oil over and above the volume required escapes past pressure regulating valve (C) and, flows through passage indicated, discharging directly into timing gear case where it lubricates timing gears and settles into scavenger pump sump from which it is returned to tank.

→→→ Front chain oil. Oil is bled from by-pass oil for front chain lubrication through passages indicated which terminate in outside breather passage. Exhausting crankcase air delivers oil vapor to chain. Oil is regulated by adjusting screw (D).

#### RETURN OIL SYSTEM (Fig. 3A-4)

J. Scavenge section of oil pump.

K. Timed "rotary" crankcase breather valve. Rotary breather valve is timed to open on downward stroke of pistons, allowing crankcase exhaust air to expel scavenge oil from crankcase into timing gearcase. This interval is indicated by arrows. →→→ During this interval, the small port in breather valve is closed. Rotary breather valve closes on upward stroke of pistons, creating vacuum in crankcase. During this interval, the small port in breather valve lines up with passage in crankcase. Oil is then retrieved by vacuum from outside breather oil trap (L) in crankcase as indicated by arrows. ←←←

L. Outside breather oil trap.

M. Crankcase oil scavenging sump.

→○→ Oil returned by gravity. Oil accumulated in cylinder head cover, drains out through passages in cylinder walls and into crankcase. Oil from hydraulic push rods drains down through the push rod covers through slots in tappet guides into timing gearcase.

→→→ Scavenge oil and crankcase exhaust air from crankcase sump (M). Exhaust air expels scavenge oil from crankcase through rotary breather valve (K), into timing gear case where the oil settles into scavenger pump sump and is returned to tank.

→→→ Crankcase exhaust air. Escapes from timing gearcase through outside breather passage which terminates in front chain guard. Any oil still carried by exhaust air is trapped in outside breather oil trap (L).

←←← Oil retrieved by vacuum. As oil accumulates in outside breather oil trap (L) in crankcase, it is retrieved by crankcase vacuum through passage as indicated.

→→→ Scavenge Oil (return oil) from engine to oil tank. Oil is pumped from engine through passages as indicated.

### ENGINE REPAIR PROCEDURE

#### GENERAL

When an engine needs repair, it is not always possible to definitely determine beforehand whether the engine can be repaired by disassembling only cylinders and heads, only gearcase; or whether engine must be completely disassembled for crankcase section repair.

Usually, only upper-end repair is needed and it is recommended procedure to first strip motorcycle for cylinder head, cylinder and piston repair as described in "Stripping Motorcycle for Engine Repair," steps 1 through 10.

After disassembling cylinder head and cylinder it may be found that lower end repair is necessary. This requires removal of engine crankcase from frame as described in steps 10 through 20 in "Stripping Motorcycle for Engine Repair."

In cases where it has been definitely determined beforehand that the lower portion of engine (crankcase) is in need of repair, remove complete engine from chassis before starting disassembly as described in steps 1 through 20 of "Stripping Motorcycle for Engine Repair."

Symptoms indicating a need for engine repair are often misleading, but generally if more than one symptom is present, possible symptom causes can be narrowed down to make at least a partial trouble diagnosis. An above normal consumption of oil, for example, could be caused by several mechanical faults (see "Locating Operating Troubles," Section 1D). But when accompanied by a blue-gray smoke from the exhaust, and when low compression is present, it indicates the rings need replacing. Low compression by itself, however, indicates improperly seated valves, not worn rings.

A noisy engine is usually caused by loose bearings. Main bearings are generally more durable than rod bearings or bushings so the latter should be suspected first. Certain "knocking" noises may be caused by loose bearings, others by piston slap, a condition where piston or cylinder or both are worn out of round and loose fitting, allowing the piston to slap from front to rear of cylinder as it moves up and down.

Most frequently, valves, rings, pins, bushings and bearings need attention at about the same time. If the symptoms can be narrowed down through the process of elimination to indicate any one of the above components is worn, it is best to give attention to all of the cylinder head and cylinder parts.

#### STRIPPING MOTORCYCLE FOR ENGINE REPAIR

Use the following procedure to strip the Duo-Glide for either cylinder head and cylinder removal for repair with engine in chassis, or for engine removal for complete overhaul.

1. To remove instrument cover take out mounting base center screw and pry off cover side plate located at trip mileage set screw.
2. Release seat clevis spring, pull clevis pin and tip seat forward.
3. Disconnect fuel line from left tank and interconnecting pipe from right tank, and drain into a proper container. Gasoline may be pumped out through tank filler opening before disconnecting pipes.

4. Remove upper and lower bolts at the front and the two stud nuts between the gasoline tanks at the rear. Remove tanks. On hand shift models, remove shift lever bottom bolt so shift lever may be removed with left tank.

5. Remove cylinder head bracket. Note washers between bracket and frame lug, use same washer when bracket is assembled. Turn bracket to disengage choke lever from carburetor.

6. Remove spark plugs to avoid damaging. Disconnect ground wire at battery.

7. Turn out center screw and remove horn power pack cover. Disconnect two wires from horn power pack. Remove two bolts mounting horn power pack to bracket. Loosen horn trumpet nut and turn horn power pack off trumpet. Remove carburetor intake manifold clamps.

8. Remove air cleaner cover, filter element, four bolts, lock washers and air cleaner back plate from carburetor body.

9. Disconnect throttle control wire from carburetor. Disconnect fuel line with fuel strainer. Remove top center crankcase nut and washer and slip carburetor mounting bracket off stud. Remove carburetor to right.

10. Remove horn trumpet mounting bolt and horn trumpet. Loosen exhaust pipe clamps and slip clamps down. Remove regulator mounting screws and move regulator away from engine cylinders. It is not necessary to disconnect wires from regulator.

At this stage, the cylinder heads and cylinders may be removed. To remove engine crankcase or complete engine, continue stripping motorcycle as follows:

11. Remove chain guard cover. If motorcycle is equipped with compensating sprocket, use Compensating Sprocket Shaft Nut Wrench, Part No. 94557-55, to remove compensating sprocket shaft nut. If not equipped with compensating sprocket, use 1-3/8 inch socket or box wrench to remove nut. Loosen nut by striking wrench handle several sharp blows with hammer. Remove push rod adjusting screw lock nut (nut on center screw on clutch sprocket), slip washer (any metal washer about 1-3/4

in. in diameter with 3/8 in. hole) over push rod adjusting screw and replace lock nut. Remove three spring tension adjusting nuts and pull clutch outer disc and spring collar assembly off clutch drive hub pins. Move clutch sprocket and motor sprocket out shafts just far enough to slip motor sprocket off shaft.

12. Remove three stud bolts, lock washers and shim washers (located between inner chain cover and engine crankcase) from inner chain cover at engine sprocket shaft.

13. Disconnect timer wire at coil. Disconnect two wires from generator.

14. Remove left rear and front motor mounting bolts.

15. Remove breather and return oil lines from oil pumps and oil tank connections.

16. Remove footboard rear stud nut from inside of frame member and front footboard mounting stud bolts from brake master cylinder by removing nut and lock washer on back side. Remove rear brake cylinder attaching stud bolt which passes through master cylinder and frame with a lock washer and nut on back side of frame member. Remove brake master cylinder sideplate bolt located behind master cylinder plunger boot. Master cylinder and sideplate assembly is free to swing down away from engine crankcase.

17. Remove muffler rear hanger clamp, muffler front hanger clamp and rear end front clamp. Remove muffler. Remove rear hanger bolt and front exhaust pipe frame clamp and remove front exhaust pipe.

18. Loosen oil feed line at tank and remove at oil pump. Have plug for pipe ready or drain oil tank before removing feed line connections. Shift line out of way and tighten connection at tank.

19. Remove spark advance control wire at circuit breaker. Remove two rear screws from horn trumpet bracket and slip out spark advance control wire.

20. Remove front and rear righthand engine mounting bolts. Engine is now completely stripped and may be removed from right side of motorcycle.

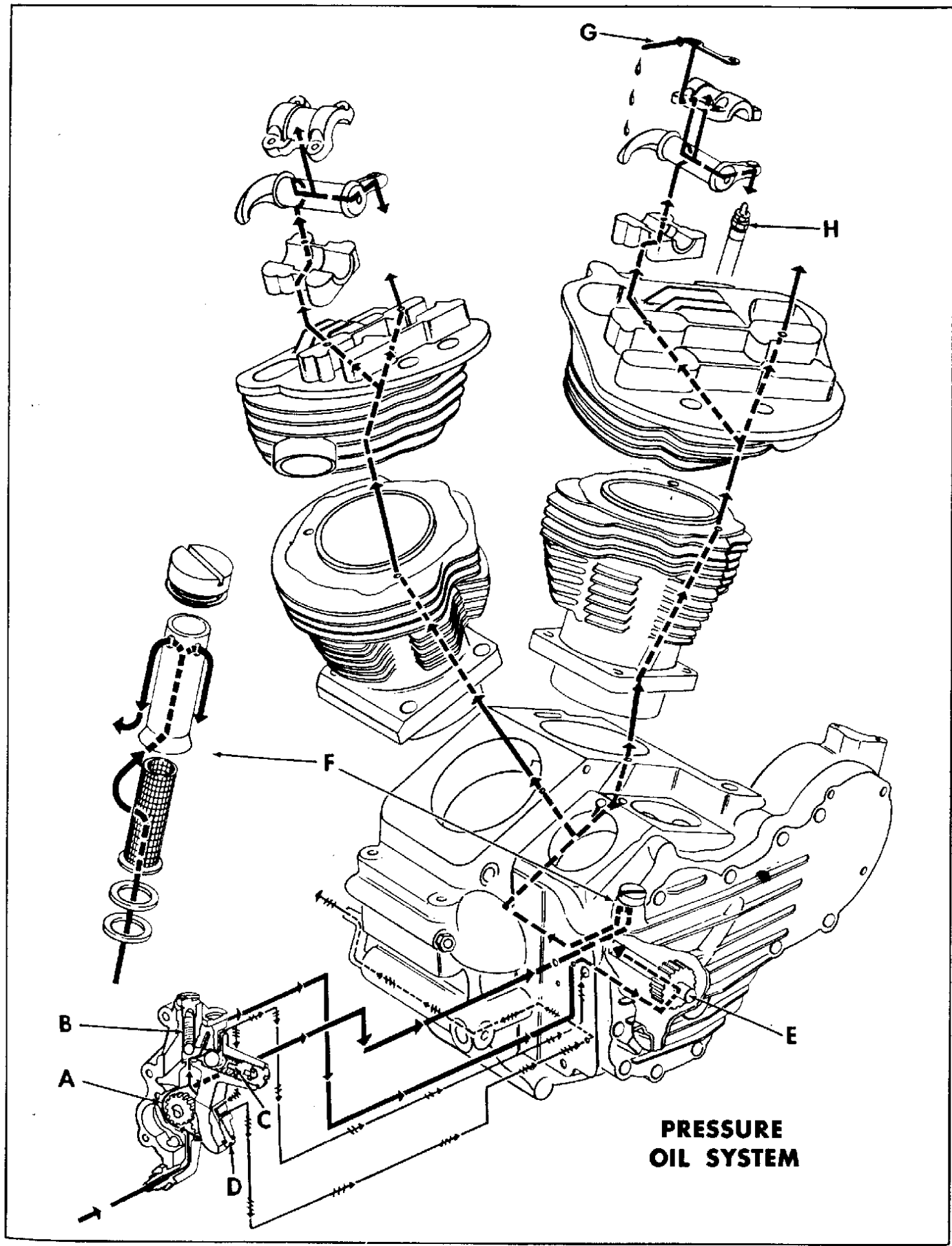

Figure 3A-3. Oil Feed Pressure System

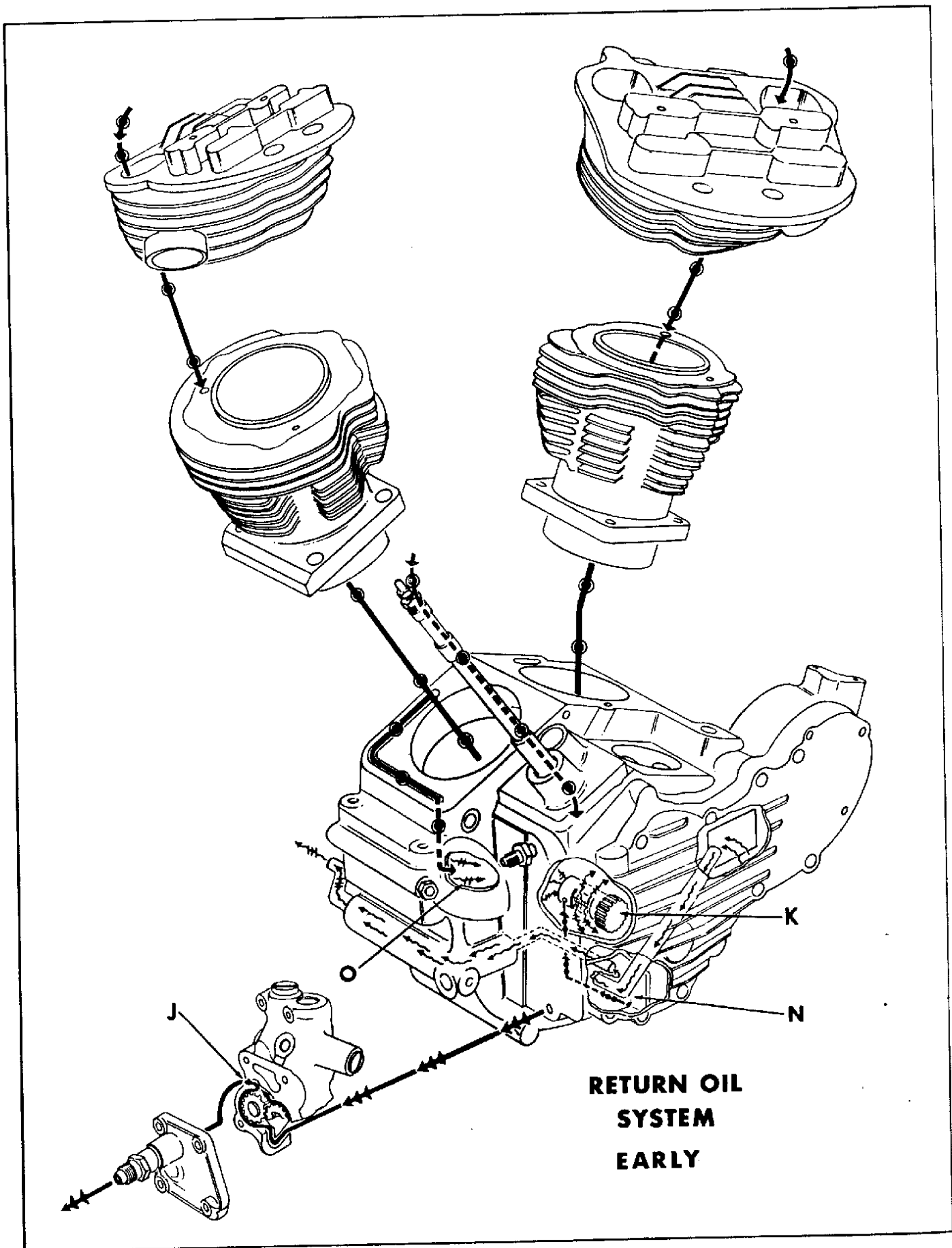

Figure 3A-4. Oil Scavenger System

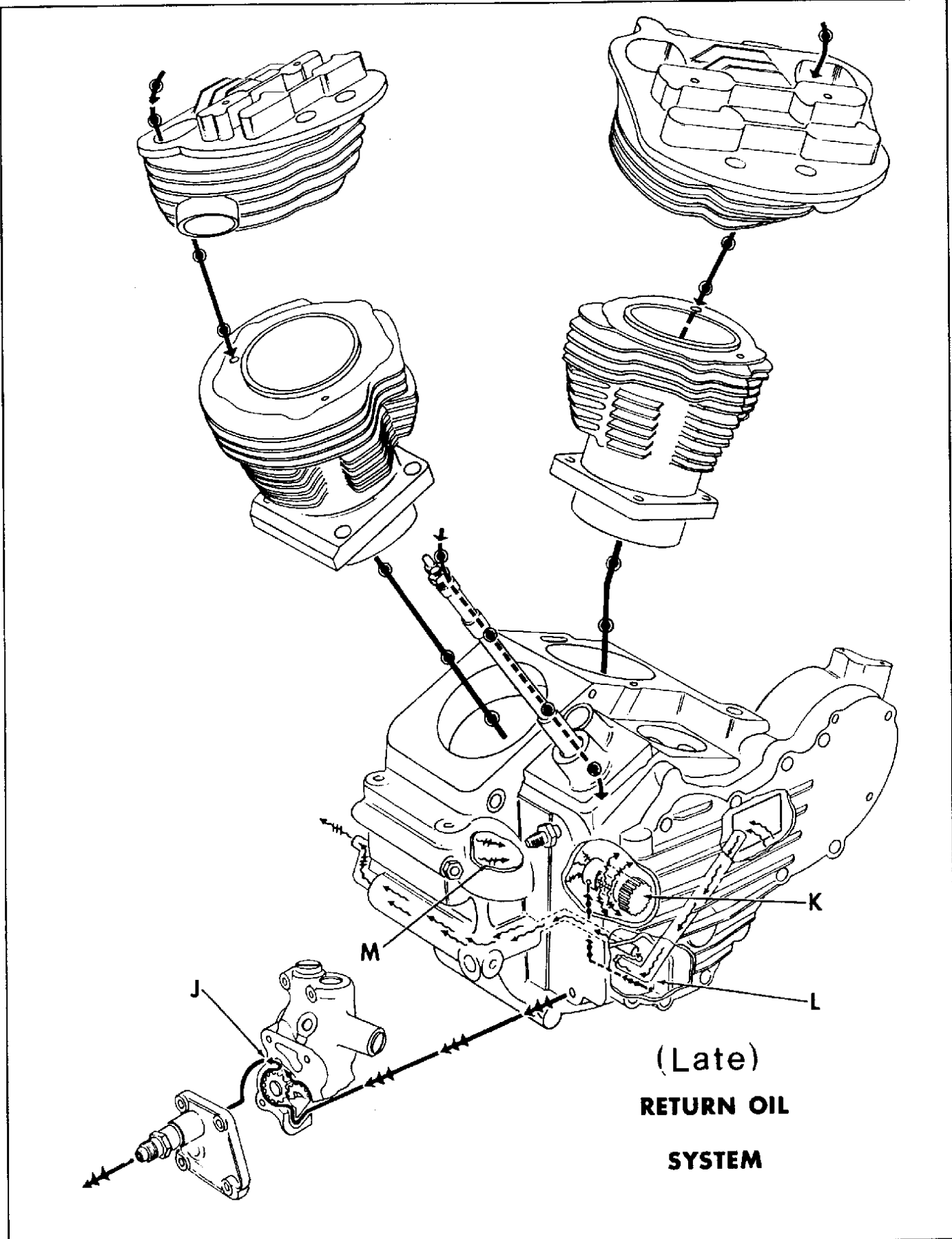

Figure 3A-4. Oil Scavenger System



## CYLINDER

### DISASSEMBLING CYLINDER AND PISTON (Fig. 3C-1)

Strip motorcycle as described in "Stripping Motorcycle for Engine Repair," , steps 1 through 10.

Remove cylinder head as described in "Disassembling Cylinder Head," Section

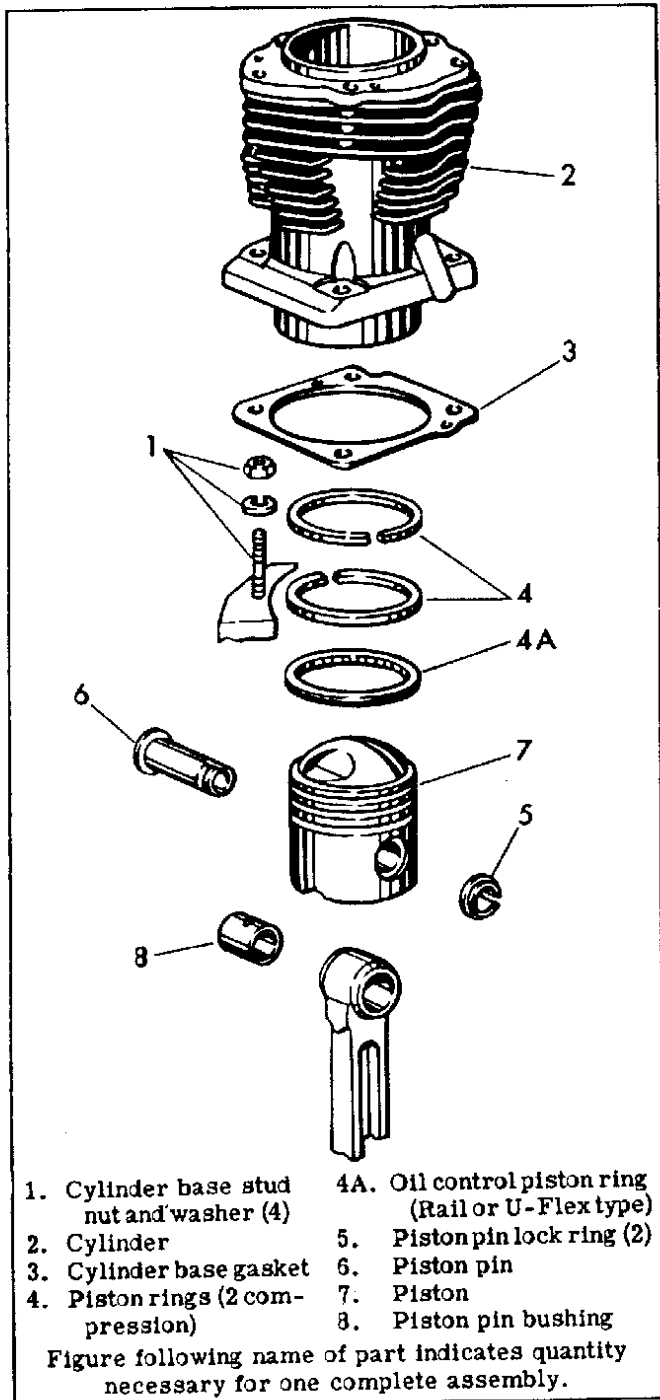

Figure 3C-1. Cylinder - Exploded View

Remove all cylinder base stud nuts and washers (1) except one on rear cylinder using Cylinder Base Nut Wrench, Part No. 94585-30. Raise front cylinder and piston enough to permit placing a cloth over crankcase opening. This will prevent dirt or pieces of broken ring from falling into crankcase. With piston at bottom of stroke, remove cylinder (2). Remove remaining stud nut from rear cylinder. Remove rear cylinder in same manner. Discard cylinder to crankcase gasket (3).

Spring piston rings (4) outward until they clear ring grooves in piston and lift off. Use a commercial ring expander if necessary. Pry right piston pin lock ring (5) off piston pin using the Piston Lock Ring Tool, Part No. 96780-32 and screwdriver as shown in Fig. 3C-2. Right end of piston pin has slots for this purpose. Tap out piston pin (6) and lift off piston (7).

Remove piston pin bushing (8), if necessary (see "Cleaning and Inspection"), using Piston Pin Bushing Tool, Part No. 95970-32. Do not drive bushing out with a drift pin unless rod is disconnected and well supported around piston pin hole.

### CLEANING AND INSPECTION

Place cylinders and pistons in "Gunk Hydro-Seal" or other carbon and gum dissolving agent until deposits are soft. Scrub piston dome and outside of cylinder to remove deposits. Where carbon deposit is thick and hard, it is advisable to scrape carbon before cleaning. Use a putty knife or ground tip on an old file. Use care to keep from scraping into aluminum of piston.

Wash all parts in solvent and blow dry with compressed air. Force air through feed and return oil passages in cylinder. Clean piston ring grooves with a piece of compression ring ground to a chisel shape.

Examine piston pin to see that it is not pitted or scored. Check the piston pin bushing to see that it is not loose in connecting rod, grooved, pitted or scored. A piston pin, properly fitted, is a light hand press fit in piston and has .001 in. clearance in connecting rod upper bearing. If piston pin to bushing free fit exceeds .002 in., replace worn parts, (see "Connecting Rod Bushings").

If piston pin is to be used again, examine lock ring on unslotted end of pin. If ring is tight in its groove, it is not necessary to remove it. When a new ring is required, clean ring groove and install ring before pin is installed in piston. The piston pin included with new piston assembly will have lock ring already installed on unslotted end.



Figure 3C-2. Removing Piston Pin Lock Ring

Examine piston and cylinder for cracks, burrs, burned spots, grooves and gouges.

Check rods for up and down play on lower bearings. See Fig. 3C-3. When up and down play is detected and either rod has more than  $\frac{3}{32}$  in. side shake at extreme upper end, lower bearing should be refitted. This requires removing and disassembling engine crankcase (see Section

#### REFINISHING CYLINDERS

Gauge pistons and cylinders to see if they are worn to the point where cylinders must be rebored and oversize pistons installed. Inside and outside micrometers used for piston to cylinder fitting should be checked together to be sure they are adjusted to read exactly the same. Subtract piston measurement from bore measurement to obtain clearance. Bore measurement of a cylinder should be taken in ring path, starting about  $\frac{1}{2}$  in. from the top of cylinder, measuring front to rear then side to side. Repeat procedure at the center and at the bottom of ring travel (see Fig. 3C-4). This process will determine if cylinder is out of round or "egged" and will also show any cylinder taper or bulge.

Pistons are measured front to rear at base of piston skirt as shown in Fig. 3C-5. Pistons are camground to an egged or oval shape so only front and rear surfaces are touching cylinder wall.

If cylinders are not scuffed, scored and are worn less than .002 in., it is not necessary to re bore oversize at time of cylinder repair. It may be done at time of next complete engine overhaul. If desired, a new piston may be installed to reduce clearance for more quiet operation.

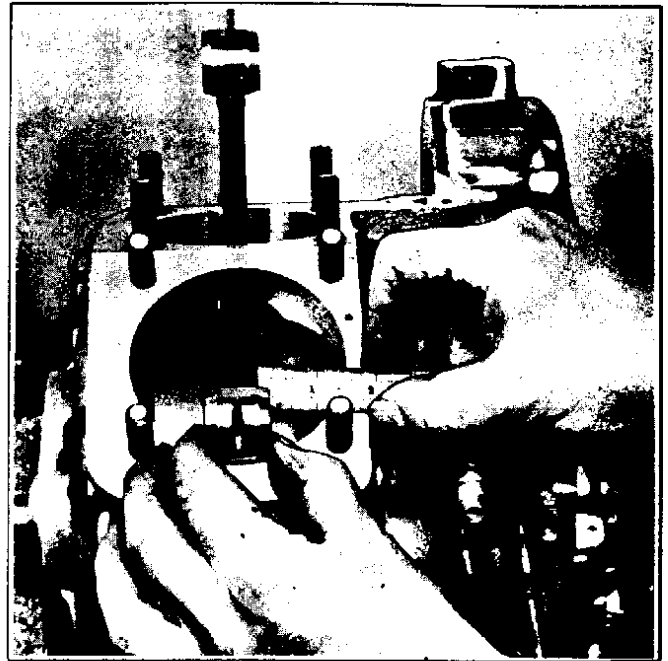

Figure 3C-3. Checking Connecting Rod Fit

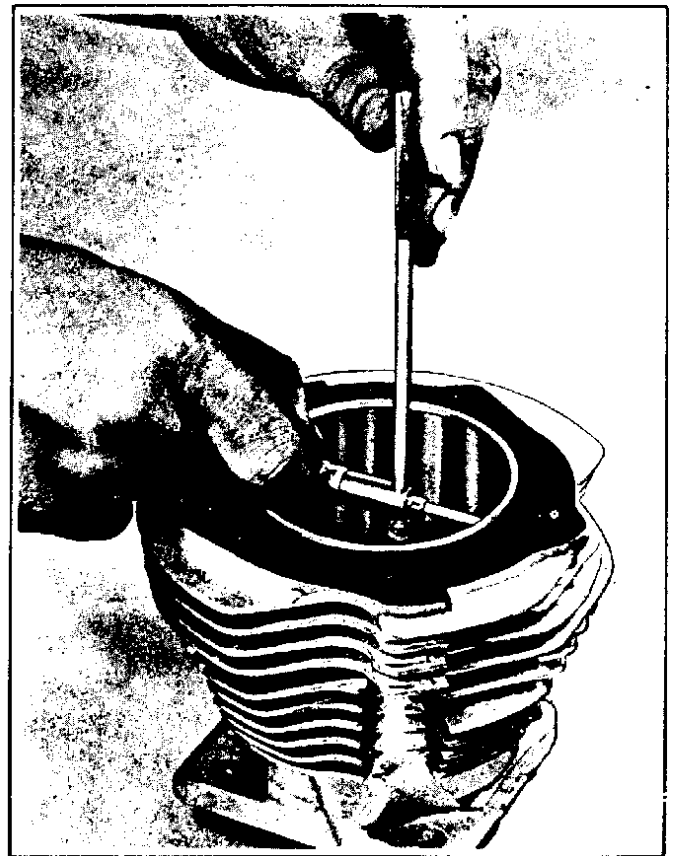

Figure 3C-4. Measuring Cylinder Bore

If cylinders show more than .002 in. wear, they should be rebored and/or honed to next standard oversize and refitted with corresponding pistons and rings.

Pistons are regularly supplied in the following over-sizes: .005, .010, .020, .030, .040, .050, .060 and .070 in. Oversize pistons have their oversize stamped on head; 10, 20, etc.

Cylinders can be refinished oversize with a hone only, or with a boring bar followed by a finishing hone. In general practice only cylinders not scored and not badly worn are refinished entirely with a hone. Cylinders badly worn or deeply scored are first rebored to nearly the required oversize and then are finish-honed to exact size. Exact final size of the cylinder bore is determined by size of the piston to be used in that cylinder. Measure piston diameter accurately as described previously, then add desired piston clearance in cylinder. This will equal the exact final size to which cylinder bore should be refinished, example: the .020 in. oversize piston to be used measures 3.4575 in., adding .001 in. (desired clearance) equals 3.4585 in. (finish-honed size). When cylinders require reboring to beyond .070 in. oversize to clean up, their oversize limit has been exceeded and the cylinders must be replaced.

When cylinders are worn less than the .002 in. maximum, and reboring is unnecessary, unless they are scuffed or grooved the same pistons may be used with the replacement of rings and the roughing of cylinder walls to facilitate ring seating. Use No. 150 carborundum emery cloth to rough walls.

**FITTING PISTON RINGS**

Piston rings are of two types - compression (plain face) and oil control ring. The two compression rings are positioned in the two upper piston ring grooves with the stamped word "TOP" or a dot (.) upward. Rings are regularly supplied in the following over-sizes to fit standard oversize pistons: .005, .010,



Figure 3C-6. Measuring Ring Side Clearance

.020, .030, .040, .050, .060 and .070 in.

Compression rings must have proper side clearance in ring grooves. In new assembly this is .004 in. Check with thickness gauge as shown in Fig. 3C-6. Maximum side clearance is .008 in. Compression ring gap (space between ends) is .010 in. to .020 in.

U-Flex oil control rings should have 11/32 in. overlap when placed free in cylinder bore. Replace ring when worn to 7/32 in. or less overlap.



Figure 3C-5. Measuring Piston

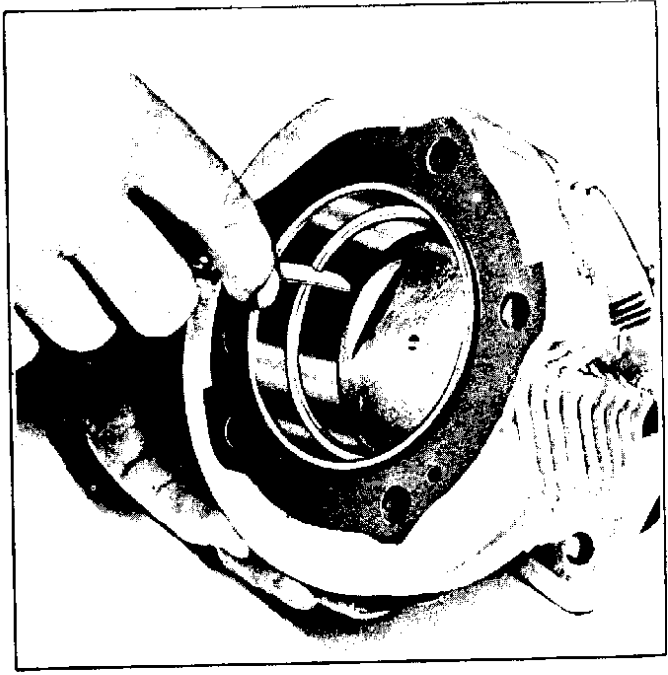

Figure 3C-7. Checking Ring Gap

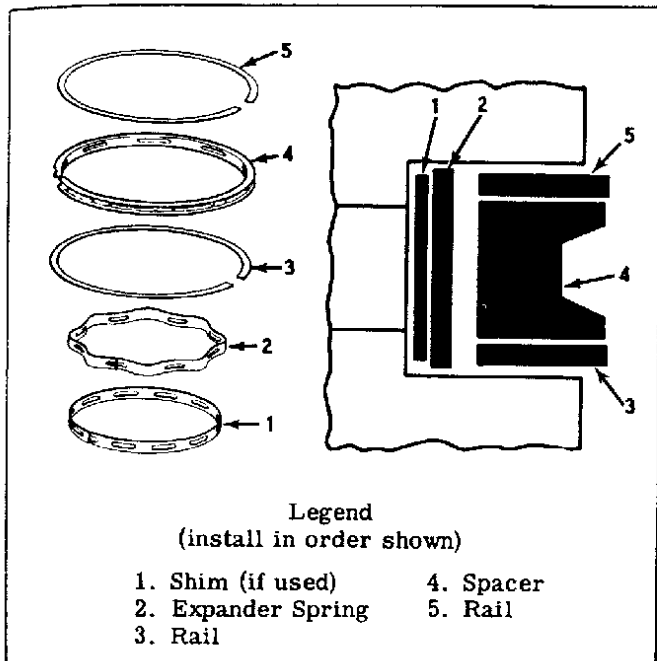

Figure 3C-8. Rail Type Oil Ring Assembly  
MEMO

**COLOR CODE ON U-FLEX OIL RING -**  
(Oposite ring gap)  
Std to .019 not marked  
.020 to .039 Light blue  
.040 to .059 Light green  
.060 to .079 Purple

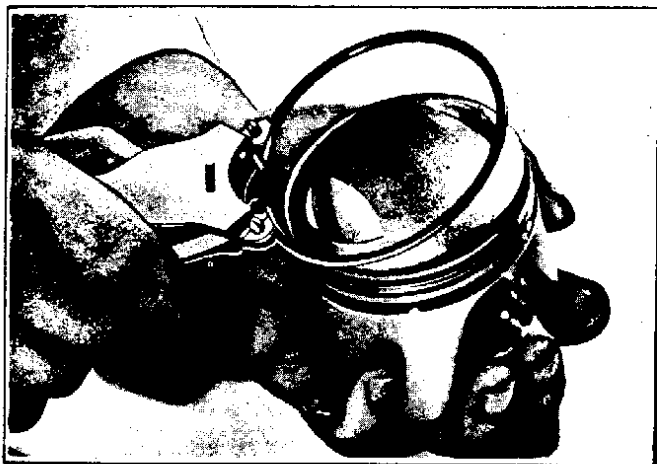

Figure 3C-9. Assembling Rings with  
Ring Expander

To check compression ring gap, place a piston in cylinder with top end of piston about 1/2 in. from top of cylinder. Place ring in cylinder bore squarely against piston and check gap with thickness gauge (see Fig. 3C-7).

Use only standard size rings and piston in standard bore, and only matching oversize rings and piston in the same oversize bore. However, .005 in. oversize rings may be used on standard piston in standard bore if ring gap with standard ring exceeds .020 in. maximum.

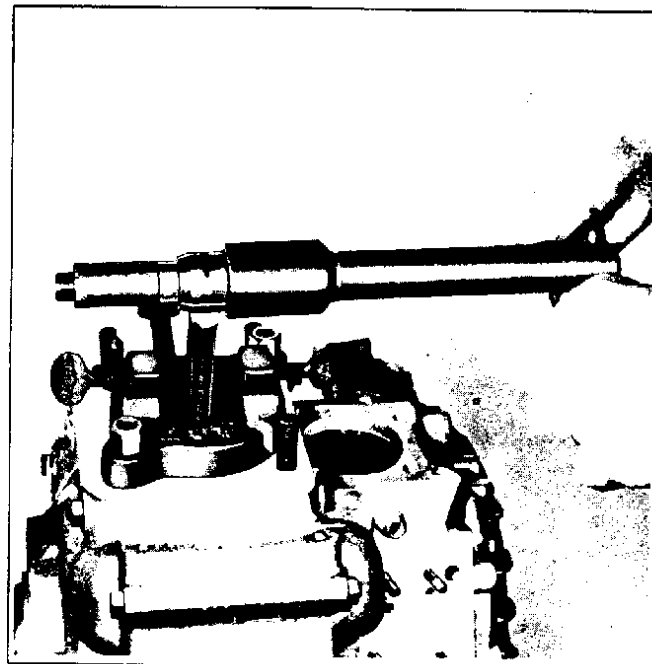

Figure 3C-10. Replacing Rod Bushing

If gap is less than .010 in., ring ends may butt under expansion, and be scored or broken. Compression ring gap may be increased by filing with fine-cut file.

Use a commercially available piston ring expander (Fig. 3C-9) to guide and slip rings over the piston into their respective grooves without over expanding or twisting rings and damaging the finely finished piston surface.

#### CONNECTING ROD BUSHING

When connecting rod bushing is tight in rod but is worn to excessive pin clearance (.002 in. or more) it is possible to service by reaming oversize and fitting an oversize pin. However, it is recommended that a new bushing be installed and reamed to fit a standard pin, except when piston to be used had previously been fitted with oversize pin, or pin is loose in bosses, necessitating fitting with an oversize pin. The objection to fitting upper end oversize is that considerably more time is required for the job. New pistons, standard or oversize, obtained from factory are supplied correctly fitted with standard pin, and may be installed in a short time if the rod bushing is already reamed to standard size. If bushing has been reamed oversize, either a new bushing must be installed and reamed to standard size or piston must be reamed oversize to fit an oversize pin, which involves extra time.

When replacing bushings in connection with only a top overhaul, use Harley-Davidson special tools as shown in Fig. 3C-10, Bushing Tool, Part No. 95970-32, and Connecting Rod Clamping Fixture, Part No. 95952-33. Be careful to start new bushing with oil slot in alignment with oil slot in rod.

Ream new bushing to size with Special Reamer, Part No. 94800-26. A properly fitted pin should have .001 in. clearance; with this clearance, pin will have just noticeable shake in bushing. Fitting tighter is likely to result in a seized pin or bushing loosened in rod. Oversize piston pins are available .002, .004, .006 and .008 in. oversize.

### STRAIGHTENING CONNECTING RODS

In refitting and reassembling connecting rods, and finally fitting pistons, rods may be bent or twisted, throwing upper bearing and lower bearing out of alignment with each other.

After pistons have been installed, rods must be checked and re-aligned as necessary. If a rod is bent or twisted, piston has a "cocked" relation to cylinder bore and the result is excessive noise and rapid wear.

Check rod alignment with Piston Squaring Plate, Part No. 96179-18 as shown in Fig. 3C-11. Be sure crankcase face is clean and free from burrs so that squaring plate seats fully.

#### NOTE

Piston skirt is cut away at bottom (below piston pin) for flywheel clearance, therefore, it cannot be used with squaring plate for checking rod alignment. Temporarily install a 61 O.H.V. piston to check rod alignment.

If a rod is in perfect alignment piston bottom will rest squarely on plate when flywheels are turned so that crank pin is in forward and rear position. This check, to be accurate, depends upon checking with crank pin alternately in both forward and rear positions. It is the change of rod angle, resulting from

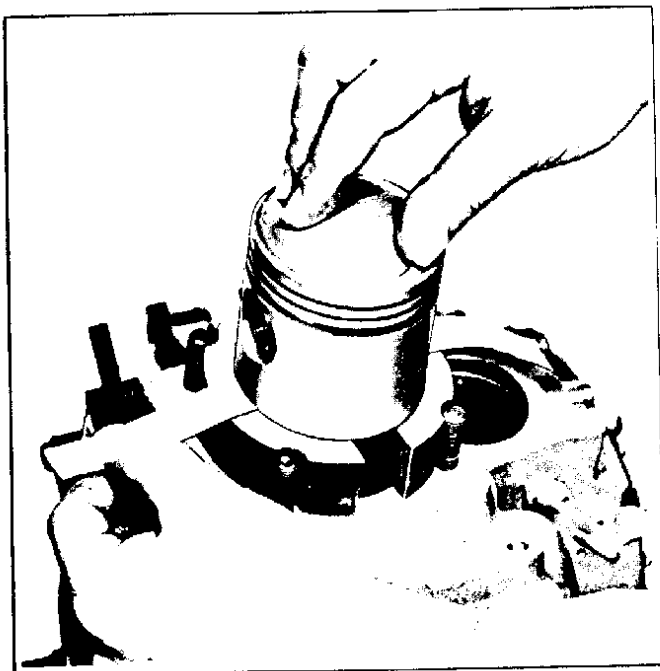

Figure 3C-11. Checking Rod Alignment

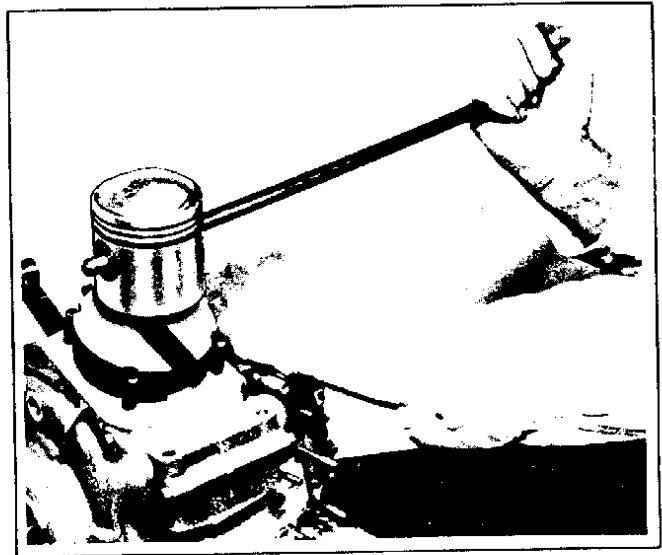

Figure 3C-12. Straightening Connecting Rod

changing crank pin from one position to the other that influences the seat of piston on squaring plate and thus indicates whether or not rod is in alignment.

Insert narrow strips of paper of equal thickness underneath piston, one on each side, below piston pin, as shown in Fig. 3C-11. Press piston down lightly with finger tips resting on center of piston head and pull first one paper, then the other, partially from underneath piston. If piston is perfectly square (rod in alignment), both will have the same amount of drag.

If rod proves to be out of alignment, it can be straightened by means of a bar inserted through piston pin, as shown in Fig. 3C-12. Use a bar with a diameter as close to the hole diameter in the piston pin as possible. The manner in which piston seats on squaring plate indicates as follows:

1. Piston high on same side, both crank pin positions; rod is bent.
2. Piston high on opposite sides as crank pin position is changed; rod is twisted.
3. Piston square or nearly square with crank pin in one position and high on one side with crank pin in other position; rod is bent and twisted.

Correct as follows:

1. To straighten a bent rod, insert straightening bar through piston pin hole on low side of piston and apply upward force.
2. To straighten a twisted rod, insert straightening bar through piston pin hole on high side of piston, and if crank pin position is to front apply force to rear - if crank pin position is to rear apply force to front.
3. To straighten a bent and twisted rod (combination of a bend and twist) remove bend first and then remove twist.

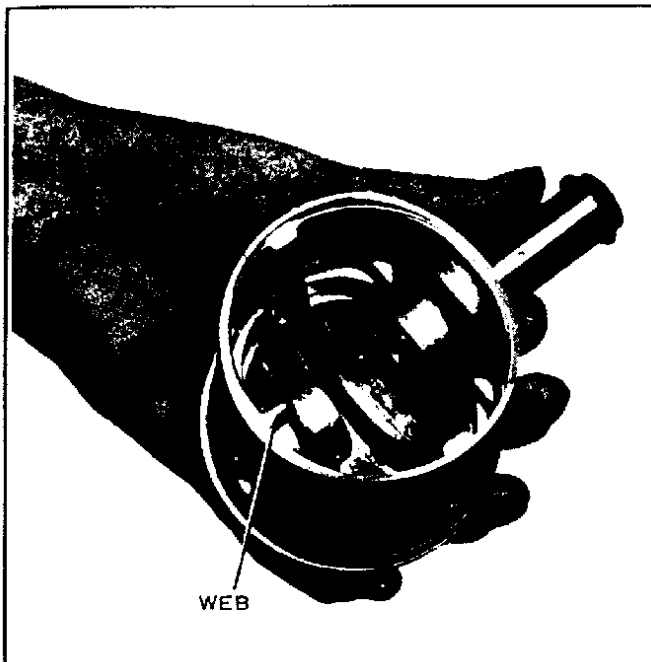

Figure 3C-13. Piston with Web on Right Side

After rods have been aligned check to see that pistons center in crankcase cylinder opening, without side pressure on upper rod ends. If further realigning is necessary to center pistons, correct by dressing off end of rod bushing on interfering side with a file. This allows the piston to shift slightly on rod to find a more suitable alignment of rod, piston, and cylinder bore.

#### ASSEMBLING CYLINDER AND PISTON

Attach piston to connecting rod with a piston pin. Position piston so lug on piston pin boss inside piston skirt is to right side of engine. See Fig. 3C-13.

Clean lock ring groove and install lock ring on end of pin that is not slotted if it was removed. Start slotted end of pin into piston boss from left side and drive through in the same manner in which pin was removed.

If the piston is heated in boiling water, the pin may be inserted into piston as a slip fit.

After pin is in place, clean lock ring groove and install the other lock ring (see Fig. 3C-14). It is important that special Lock Ring Tool, Part No. 96780-32 be used for installing lock rings.

#### NOTE

Lock ring is expanded just enough to go over end of pin. Other means of installing may over-expand ring and possibly crack it. Make sure ring groove is clean and that ring seats firmly in groove.

A lock ring incorrectly installed will soon loosen in service and finally come off pin, resulting in both piston and cylinder being damaged beyond repair. Never install a used lock ring or a new one that has been installed and then removed. Always use an unused lock ring.



Figure 3C-14. Inserting Piston Pin Lock Ring

Lubricate cylinder walls, pistons, pins and rod bushings with engine oil. Rotate rings until gaps are equidistant around rear piston. Turn engine until crank pin is at bottom center. Install new cylinder base gasket. Position Piston Inserter Ring Tool, Part No. 96333-51 on rear piston and slip rear cylinder down over piston as shown in Fig. 3C-15.

Install lock washers and nuts and pull them down evenly. Repeat process to assemble front cylinder.

Assemble cylinder heads and remaining portions of motorcycle as indicated in "Assembling Cylinder Heads," Section 3B, and reverse order of "Stripping Motorcycle for Engine Repair," Section , steps 10 through 1.

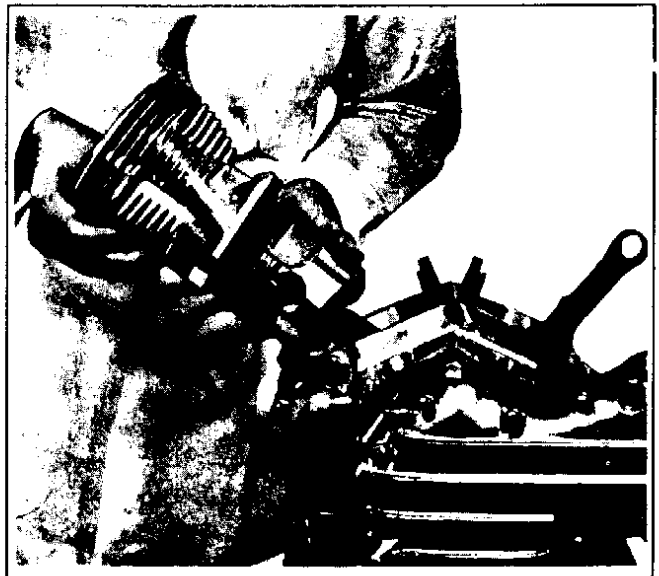

Figure 3C-15. Slipping Cylinder over Piston

TOP

## CYLINDER REBORING AND PISTON FITTING INFORMATION

(Note: Dimensions given are standard size.)

Standard bore  
dimension of  
cylinder.

45" Side Valve Models (1935 and later)	2.745"
74" Side Valve Models (1935 and 1936, and all 80")	3.422"
74" Side Valve Models (1937 to 1948)	3.3125"
61" Overhead Valve Models (1936 and later)	3.3125"
74" Overhead Valve Models (1941 and later)	3.4375"
125 c.c. Models (S and Hummer)	2.0625"
165 c.c. Models (ST and STU)	2.375"
K and KH Models	2.745"

All Models except 125 c.c. Models and 165 c.c. Models -- piston should be fitted .001" to .002" clearance in cylinder, checking fit at bottom of skirt, front to rear.

125 c.c. Models -- piston should be fitted .003" to .004" clearance in cylinder, checking fit at bottom of skirt, front to rear.

165 c.c. Models -- piston should be fitted .0025" to .0035" clearance in cylinder, checking fit at bottom of skirt, front to rear.

## NEW STRONGER PISTON PIN USED IN ALL TWIN MODEL ENGINES

A stronger piston pin (.7915" diameter and oversizes) with thicker wall is now used in all twin model engines. The greater wall thickness, of course, reduces the diameter of hole through pin.

The new pin is now being assembled in all new engines and is also furnished on all parts orders calling for piston pin, or piston with pin.

If you already have piston pin lock ring tool, Part No. 96780-32, which you no doubt have, you will need a new lock ring tapered expander with smaller diameter shaft before tool can be used to install lock ring on new pin. The ring expander you need is available under Part No. 96781-52. Understand, this number covers only the new tapered expander required.

Complete piston pin lock ring tool ordered in the future under Part No. 96780-32 will be supplied with two lock ring tapered expanders - one to fit the earlier piston pin and one to fit the new. We will continue, for some time, to supply with the complete tool the expanding arbor that fits the earlier pin, because of the many engines in service fitted with earlier pin, and because of the earlier pins in dealers stocks.

To drill early OHV cylinder walls for u-flex oil rings drill hole into return channel 1 3/16" from bottom of cylinder. Use 1/4" drill at 35° angle.

# SHOP DATA:

## Pistons and Rings for 1948 O.H.V. Models

256-48 A Piston with rings and pin-standard size  
High Compression 1948 - 61" O.H.V.

Note: This piston assembly includes one new oil control ring and two compression rings.

The above piston supplied in oversizes listed below:

256-48 C	.005 O.S.	256-48 G	.040 O.S.
256-48 D	.010 O.S.	256-48 H	.050 O.S.
256-48 E	.020 O.S.	256-48JA	.060 O.S.
256-48 F	.030 O.S.	256-48KA	.070 O.S.

22141-48 Piston with rings and pin-standard size  
Low Compression 1948 - 61" O.H.V.

Note: This piston assembly is not shown in 1948 parts book but is used on 1948 E (low compression) motors. It includes one new oil control ring and two compression rings.

The above piston supplied in oversizes listed below:

22142-48	.005 O.S.	22146-48	.040 O.S.
22143-48	.010 O.S.	22147-48	.050 O.S.
22144-48	.020 O.S.	22148-48	.060 O.S.
22145-48	.030 O.S.	22149-48	.070 O.S.

256-41 Pistons no longer used on 1948 - 74" O.H.V. models. Correct parts book to read 1941 to 1947 - 74" O.H.V. See below for 1948 - 74" O.H.V. pistons.

22101-48 Piston with rings and pin-standard size  
High Compression 1948 - 74" O.H.V.

Note: This piston assembly includes one new oil control ring and two compression rings.

The above piston supplied in oversizes listed below:

22102-48	.005 O.S.	22106-48	.040 O.S.
22103-48	.010 O.S.	22107-48	.050 O.S.
22104-48	.020 O.S.	22108-48	.060 O.S.
22105-48	.030 O.S.	22109-48	.070 O.S.

255-48A Piston with rings and pin-standard size  
Low Compression 1948 - 74" O.H.V.

Note: This piston assembly includes one new oil control ring and two compression rings.



# SHOP DATA:

The above piston supplied in oversizes listed below:

255-48 C	.005 O.S.	255-48 G	.040 O.S.
255-48 D	.010 O.S.	255-48 H	.050 O.S.
255-48 E	.020 O.S.	255-48JA	.060 O.S.
255-48 F	.030 O.S.	255-48KA	.070 O.S.

262-48 Set of piston rings-standard size 1948 61" O.H.V.  
 Consists of 4 265-48 Piston Compression rings  
 2 22374-49 Piston oil ring.

The above sets can be supplied in oversizes listed below:

262-48 C	.005 O.S.	262-48 G	.040 O.S.
262-48 D	.010 O.S.	262-48 H	.050 O.S.
262-48 E	.020 O.S.	262-48JA	.060 O.S.
262-48 F	.030 O.S.	262-48KA	.070 O.S.

262-41 Set of piston rings no longer used on 1948 - 74" O.H.V. Change parts book to read 1941 to 1947 - 74" O.H.V. For 1948 - 74" O.H.V. order as follows:

22355-48 Set of piston rings-standard size 1948 74" O.H.V.  
 Consists of 4 265-41 Piston Compression rings  
 2 22364-49 Piston oil rings

The above sets can be supplied in oversizes listed below:

22356-48	.005 O.S.	22360-48	.040 O.S.
22357-48	.010 O.S.	22361-48	.050 O.S.
22358-48	.020 O.S.	22362-48	.060 O.S.
22359-48	.030 O.S.	22363-48	.070 O.S.

Void 102-48 Rocker arm socket. Order rocker arm instead.

Add 109-48 Welsh plug for rocker arms, small O.H.V. Models  
 Add 109-48A Welsh plug for rocker arms, large O.H.V. Models  
 Void 263-48 Oil control ring (Police). Use 22374-49 oil control ring.  
 Void 266-48 Oil control ring. Use 22374-49 oil control ring.  
 Change 265-41A Oil control ring to 1941 to 1947 74" O.H.V. for City Police  
 (Note: 265-41A is also to be used in all early 1948 74" O.H.V.)  
 Change 587-41 to read 1941-1947 O.H.V. Do not use 1947 style pump on 1948  
 motors, or 1948 pump on earlier motors.  
 Add 587-48 Oil pump assembly 1948 O.H.V. models  
 Change 683-41 Oil pump cover plate to 1941 to 1947 O.H.V.  
 Add 683-49 Oil pump cover plate 1948 to 1949 O.H.V.  
 Void 703-48 Check valve spring  
 Change 703-36 Check valve spring to 1936-61" O.H.V., 1937 to 1949

## CYLINDER HEAD

### REMOVING CYLINDER HEAD ASSEMBLY (Fig. 3B-1)

Remove spring cap retainers (1) on push rod covers by prying down on cover spring cap with screwdriver wedged between cylinder cooling fins and pulling spring cap retainers out.

Remove five head bolts and washers (2) from each head. Lift cylinder head enough to slip out push rods (3) and push rod covers (4). Remove cylinder head (5). Remove cylinder head gasket (6). Mark push rods so that they will be reassembled in same position.

### DISASSEMBLING CYLINDER HEAD

Remove the 12 cover reinforcing screws (7) and lift off reinforcing ring (8), rocker arm cover (9) and cover gasket (11). Cover pad (10) is cemented inside cover and needs no attention if in serviceable condition.

Turn off the eight rocker arm bearing stud nuts (12), and lift intake valve oiler (13) off studs. Remove rocker arm bearing halves (14 and 16) with rocker arms (15).

Remove exhaust valve stem pads (17). Compress valve springs with Valve Spring Compressor, Part No. 96600-36, as shown in Fig. 3B-2. Remove valve key halves (18).

### NOTE

On FLH engines, valve stem pads are not used and valve key is split wedge type.

Remove upper valve spring collar (19), outer valve spring (20) and inner valve spring (21) and lower spring collar (22). Slip valves (23) out of valve guides in head.

Do not interchange valves, rocker arms or rocker arm bearing halves. Either process parts separately or mark them in some manner so they may be returned to their respective positions.

### CLEANING AND INSPECTION

Clean outside of cylinder head with a wire brush. Scrape carbon from head, top of cylinder, top of bore above ring path, and inlet and exhaust valve ports. When scraping carbon, be careful to avoid scratching or nicking cylinder head and cylinder joint faces or bore. Blow off loosened carbon or dirt with compressed air.

Wash all parts in Harley-Davidson "Gunk Hydro-Seal". Blow out oil passages in head. Be sure they are free of sludge and carbon particles. Remove loosened carbon from valve head and stem with a wire wheel. Never use a file or other hard-

ened tool that will scratch or nick valve. Polish valve stem with very fine emery cloth or steel wool. Check valve stem for excessive wear.

Valve head should have a seating surface about 1/16 in. wide, it should be free of pit marks and burn spots. Exhaust valves should contain carbon that is black or dark brown. White or light buff carbon indicates excessive heat and burning.

Valve seats are also subject to wear, pitting and burning. They should be resurfaced whenever valves are refinished. Clean valve guides with the Harley-Davidson Valve Guide Reamer, Part No. 94830-47, and check for wear and valve stem clearance.

Inspect valve springs for broken or discolored coils. Check free length or check tension of each spring. If a spring is more than 1/8 in. shorter than a new spring, or tension shows spring to be below low limit tension of new spring, replace it with a new spring. Check valve spring compression with valve spring tester against tolerances shown in "Engine Specifications," Section 3A.

Examine push rods. Replace any rods that are bent, discolored or broken. Check cup at end of rocker arm to make certain there are no chips broken out.

Blow out oil passages in rocker arms, rocker arm bearings and replace intake valve oilers. When used valve oilers are cleaned and reinstalled, they invariably allow over-oiling. Assemble units on head (dry) and check rocker arm clearance in bearing. If rocker arm fit in bearing is greater than .002 in., repair bearings that are otherwise serviceable as follows: Remove locating dowel pins from bearing covers and sand matching faces of top and bottom rocker arm bearing halves on a sheet of emery cloth laid on a fairly true firm surface. Sand both halves an equal amount. Wash parts and assemble (with dowel pins) to cylinder head, but omit rocker arm. Line ream hole in bearing with a standard 7/8 in. reamer. Disassemble, wash parts and reassemble, including rocker arm. Check fit and repeat sanding and reaming procedure until desired tolerance fitting is reached. Rocker arms must be free in bearings or hydraulic lifters will not fill with oil. Always strike sides of rocker bearings a medium blow to align parts before checking fit.

If end of rocker that bears against end of valve stem is worn, dress down on emery wheel to regain original contour. Compare with unused part for correct shape.

### REPLACING VALVE GUIDES

Replacing valve guides (24, Fig. 3B-1) if necessary, must be done before valve seat and face are ground since the valve stem hole in valve guide is the basis from which all face and seat grinding is done.

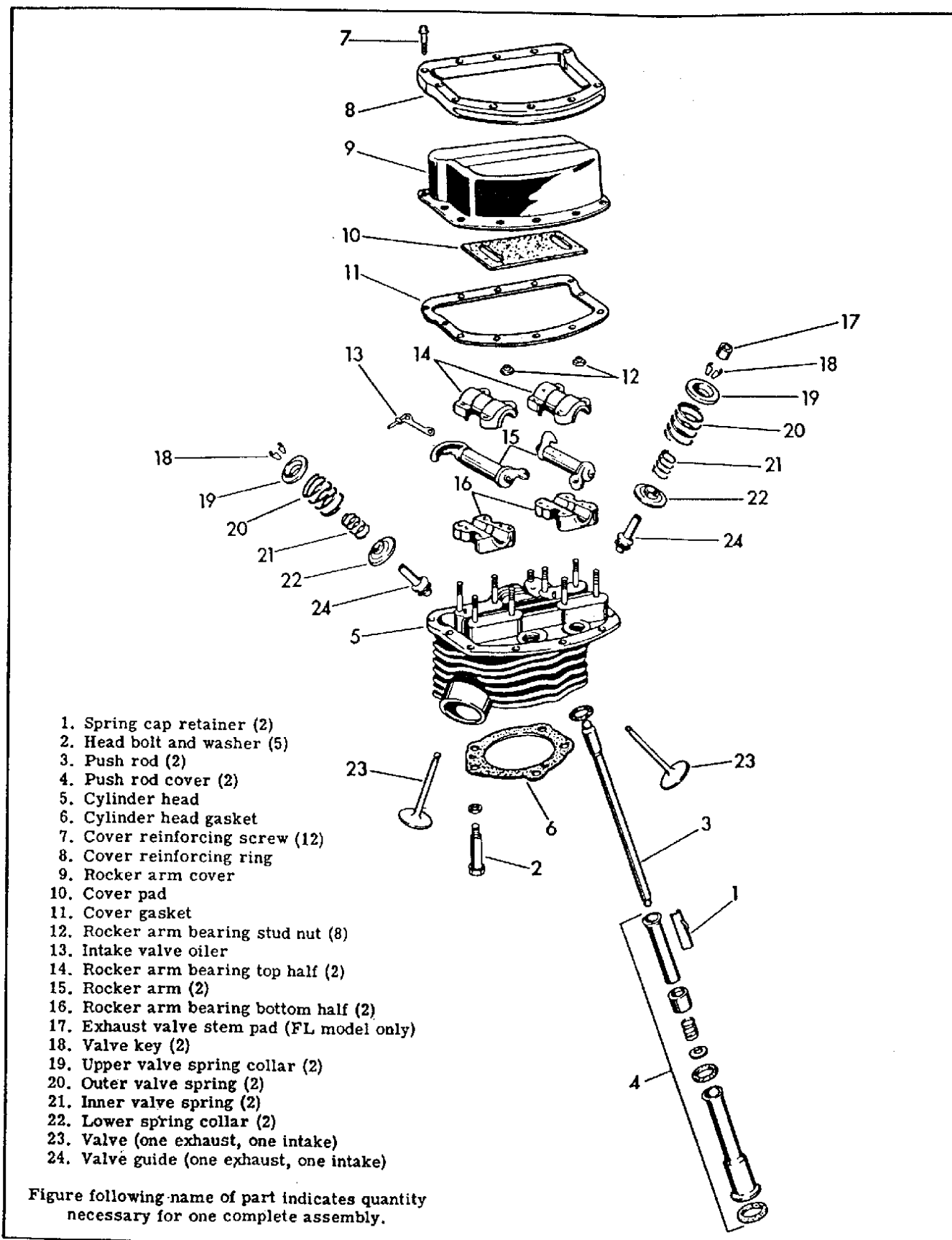

Figure 3B-1. Cylinder Head - Exploded View

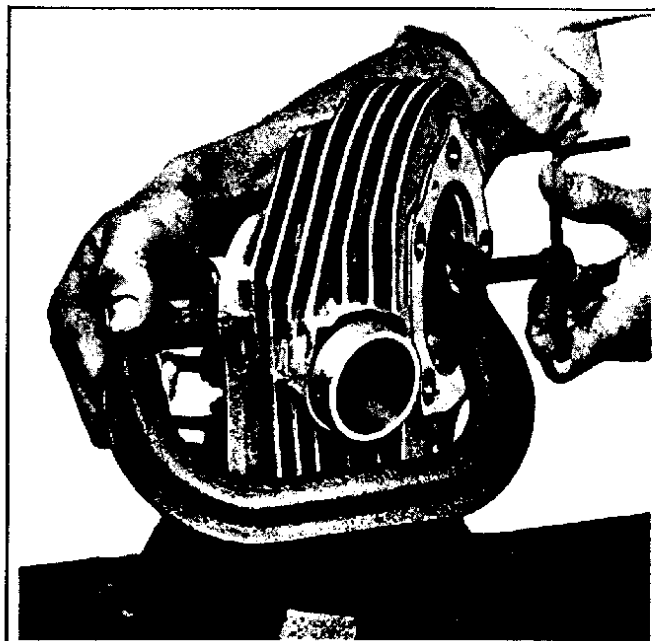

Figure 3B-2. Compressing Valve Spring

Valve stem-valve guide clearance is as follows: Exhaust valves, .004 in. to .006 in. loose; intake valves, .002 in. to .004 in. loose. If valve stems and/or guides are worn to exceed the maximum tolerances by more than .002 in., new parts must be installed.

Tap out valve guides with shouldered drift pin (from chamber side) and insert replacement guide on arbor press. Be particularly careful to press replacement guide squarely into hole.

New valve guides are reamed to correct size. However, when guides are pressed into cylinder heads, they may close up slightly; also the ends may be burred. Therefore, after new guides are in place, they should be sized and cleaned with Valve Guide Reamer, Part No. 94830-47.

It is of prime importance that valve guides fit tightly in cylinder heads, or valves may not seat properly. If original guide or new standard guide is not a tight press fit, an oversize guide must be installed. Oversize guides can be obtained .001 in. to .006 in. oversize.

#### REPLACING VALVE SEATS

After installing valve guides, valve seats must be refaced to true them with guides.

If valves have been resealed several times, valve seats may have become too wide and/or valve may be seating itself too deeply in head. When valve seat becomes wider than 1/16 in. (see Fig. 3B-3) valve seat relief must be counterbored to reduce seat to 1/16 in. Counterbore dimensions are shown. Tools for this purpose are available commercially. To determine if valve is seating itself too deeply in head, measure distance from shoulder of valve guide to end of valve stem. See dimension in Fig. 3B-3. When valve

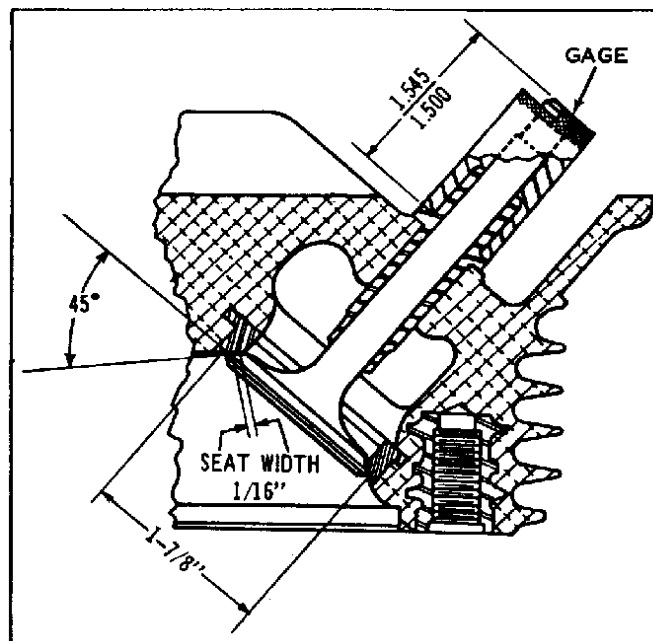

Figure 3B-3. Valve Seat Tolerance

stem extends through guide excess of maximum shown valve seat inserts must be replaced, or an oversize valve installed.

A special gage is available under Part No. 96490-59 which is used to measure this dimension. The tool consists of a gage valve and gage which is placed over the valve stem as shown. If top end of gage valve stem is between steps on gage, the valve seat location is satisfactory.

Cylinder heads may be returned to factory through authorized Harley-Davidson dealer for valve seat insert replacement. Heads are bored out to remove old seats, and new seats are pressed into place.

#### GRINDING VALVE FACES AND SEATS

Valve seat grinding tools and fixtures are available commercially. Grind and seat each valve in same port from which it was disassembled.

Valve face angle is 45° for both intake and exhaust valves, and valve refacing grinder must be adjusted exactly to this angle. It is important to not remove any more metal than is necessary to clean up and true valve face. If grinding leaves the edge of valve very thin or sharp, install a new valve. A valve in this condition does not seat normally, will burn easily and may cause pre-ignition. There is also danger of cracking. Valves that do not clean up quickly are probably warped or too deeply pitted to be used.

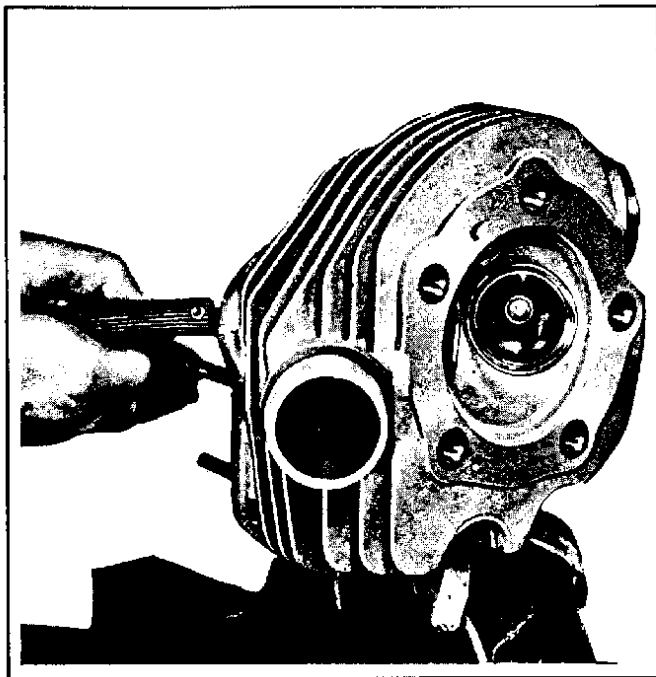

Figure 3B-4. Lapping Valves

If end of valve stem shows uneven wear, true end of stem on a valve refacing grinder equipped with suitable attachment.

Standard intake and exhaust valves are made of different materials and must not be interchanged. Intake valves are marked "IN" on head; exhaust valves are marked "EX".

#### LAPPING VALVE FACES AND SEATS

If valve faces and seats have been smoothly and accurately refaced, very little lapping will be required to complete seating operation. Apply a light coat of fine lapping compound to valve face, insert valve in guide and give it a few oscillations with Valve Grinding Tool, Part No. 96550-36. Lift valve and rotate it about  $\frac{1}{3}$  of a turn. Repeat lapping procedure as shown in Fig. 3B-4. After full turn, remove valve, wash valve face and seat, and dry with cloth that is immediately discarded so grinding compound cannot be transferred to engine parts. If inspection shows an unbroken lapped finish of uniform width around both valve and seat, valve is well seated. If lapped finish is not complete, further lapping, or grinding and lapping is necessary.

#### ASSEMBLING CYLINDER HEAD

Replace valve and valve spring assemblies using Valve Spring Compressor, Part No. 96600-36. Position valve keys so spaces between key halves are equal. Spaces between key halves must face front and rear of engine on intake valves.

Replace rocker arm assemblies making sure intake valve oiler is in place on intake rocker bearing, with oiler tube  $\frac{3}{32}$  in. from rocker arm. Rocker arms must be free or hydraulic lifters will not fill with oil.

Replace rocker arm cover and reinforcing ring. Use new cover gasket. Pull down cover reinforcing screws evenly to obtain tight seal.

Install new cylinder head to cylinder gasket and position rear head. Start cylinder head bolts. Turn engine until front cylinder exhaust tappet is just starting upward. Install rear cylinder exhaust push rod and push rod cover. Make certain both push rod ends are properly seated in rocker arm and tappet.

Rotate engine until front cylinder intake tappet is just starting upward. Install rear cylinder intake push rod in same manner as exhaust push rod. Tighten head bolts evenly to insure a proper seal. First turn bolts snug, then using a torque wrench tighten each  $\frac{1}{4}$  turn at a time until all are drawn to 65 ft. lbs.

Repeat procedure to install front cylinder head.

#### ADJUSTING TAPPETS (Fig. 3B-5)

Engine must be cold. Loosen tappet adjusting lock nut (1) and turn adjusting screw (2) upward, shortening push rod, until push rod has noticeable shake. Keep push rod from turning by holding with wrench on flats provided at base of push rod (3). Slowly turn push rod adjusting screw downward, lengthening rod, until all shake has been taken up. Mark adjusting screw with chalk and turn it downward exactly four full turns. Lock adjustment by tightening tappet adjusting lock nut. Always adjust tappets with push rod at its lowest position. Lowest position may be found by rotating engine until like tappet (intake or exhaust) in other cylinder is at highest point (valve fully open).

Install push rod cover spring cap retainers.

Always use new gasket at all joints unless otherwise specified. Clean off surfaces with a greaseless solvent (white gasoline is satisfactory) and install gaskets dry. Greased gaskets adhere to joint surfaces and become impossible to remove without damaging joint surfaces.

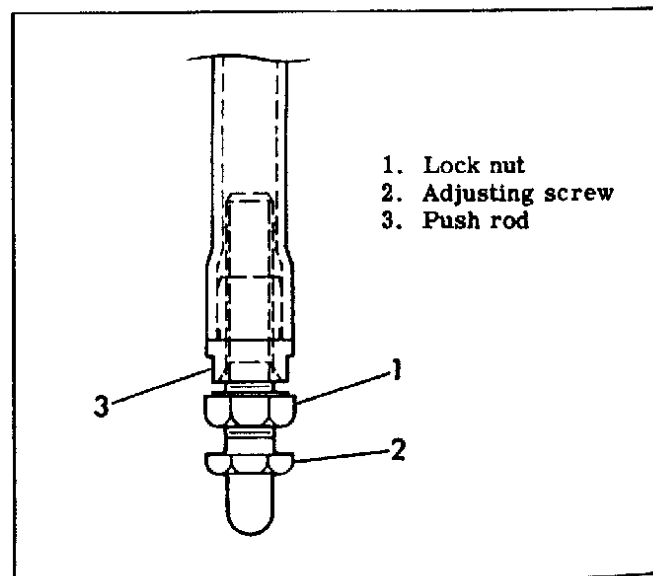

Figure 3B-5. Adjusting Tappets

# SHOP DATA

## VALVE GUIDES, BIG TWIN OHV

Production engines with aluminum cylinder heads have always been supplied from the factory with steel intake valve guides, and with bronze exhaust valve guides starting in 1950. However, valve guides for parts order have been bronze for both intake and exhaust since 1950.

Because of recent changes, subsequently outlined, bronze valve guides will no longer be used for Big Twin OHV Models.

### Exhaust Valve Guides

A change in exhaust valve guide material has been made, starting approximately February 1, 1957, in all Big Twin OHV engines. Valve guide material has been changed from bronze to a special steel alloy. This material is superior to the bronze alloy which it replaces, because of its greater resistance to wear at high temperatures.

The new steel exhaust valve guides will be supplied for parts order under the following part numbers:

18188-48A	(Standard)
18189-48A	(.001" oversize)
18190-48A	(.002" oversize)
18191-48A	(.003" oversize)
18192-48A	(.004" oversize)
18193-48A	(.006" oversize)

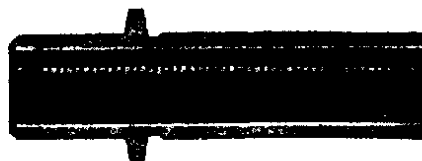

Steel Exhaust Valve Guide

Above steel exhaust valve guides will be supplied henceforth on all orders received at the factory for the following replacement valve guides:

18188-48	(Standard)
18189-48	(.001" oversize)
18190-48	(.002" oversize)
18191-48	(.003" oversize)
18192-48	(.004" oversize)
18193-48	(.006" oversize)

Bronze guides which you now have in stock under above part numbers can be used up by using in intake valve position in Big Twin OHV engines.

### Important:

Some bronze valve guides in your stock under above part numbers may have a female thread in the valve guide hole which is intended to improve valve stem lubrication. Such guides are not approved for use in intake position, because excessive oil may pass by valve stem into combustion chamber. Therefore, use only guides with a smooth bore for intake position. Examine all of your bronze guides under above part numbers to determine if guide bore is threaded. Return threaded bronze guides to the factory for credit or exchange.

# SHOP DATA:

## INSTALLING HIGH LIFT CAM GEAR - PART NO. 25522-51R

(This cam gear is to be used only in 1948 and later 74 O.H.V. engine)

When this cam is installed the valves will be opened an additional  $1/32$ " therefore it will be necessary to check the dimensions shown on drawing to be sure there will be at least  $.020$ " clearance between upper valve spring collar and end of valve guide when valve is open. When valve is on seat as shown this dimension should be at least  $7/16$ ".

If engine is not to be removed from chassis and reconditioned at time of installation it will be necessary to at least remove and disassemble heads so dimension given above can be checked.

After any needed refacing and reseating of valves is completed install each valve, upper spring collar and keepers for check. The parts used when making this check should be used in final assembly of engine in the same locations as when check was made.

If upper collar does not have the required  $7/16$ " clearance from guide grind end of guide off with hand grinder if available. If suitable grinder is not available remove guide so that it can be shortened with tools available. Bear in mind that if guide is removed and replaced it will be necessary to true up valve seat to conform with guides new location.

When installing cam gear ascertain that end play is correct. This should be  $.001$ " to  $.005$ " adjusted by variable thickness washer - Part No. 664-36

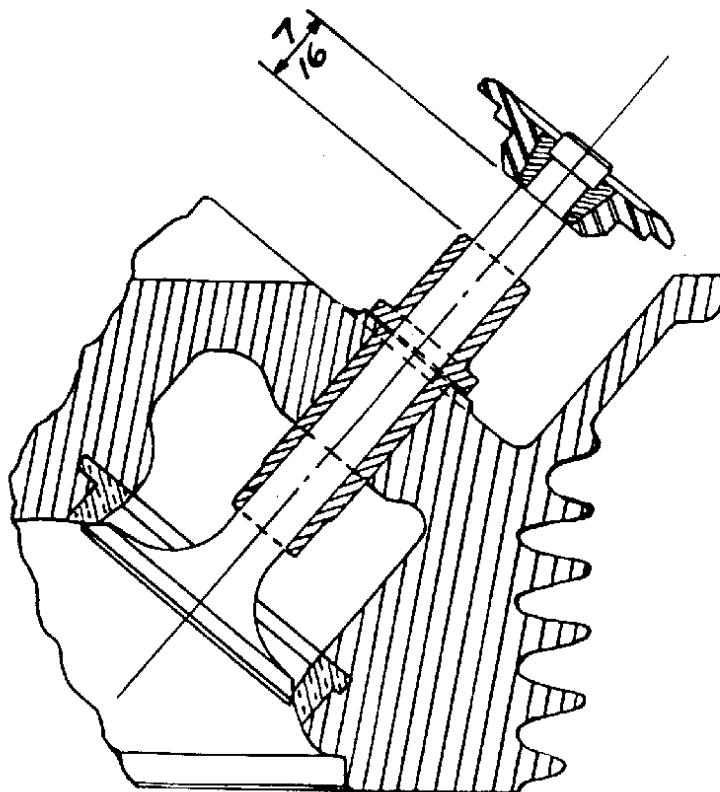

Intake Valve Guides

Steel intake valve guides have always been used for production Big Twin OHV engines. The special steel material used has proven its resistance to wear, and for this reason is now being made available for replacement guides.

The steel intake valve guides will be supplied for parts order under the following part numbers:

- 18163-48 (Standard)
- 18164-48 (.001" oversize)
- 18165-48 (.002" oversize)
- 18166-48 (.003" oversize)
- 18167-48 (.004" oversize)
- 18169-48 (.006" oversize)

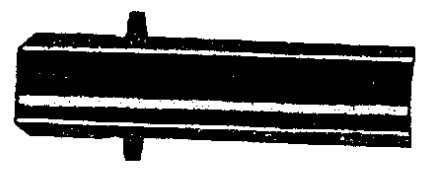

Steel Intake Valve Guide

Note:

All oversize valve guides supplied on parts order are identified with grooves cut around outside at top end, the number of grooves (one to six) indicating .001" increase in outside diameter over standard for each groove. Standard size guide is not grooved.

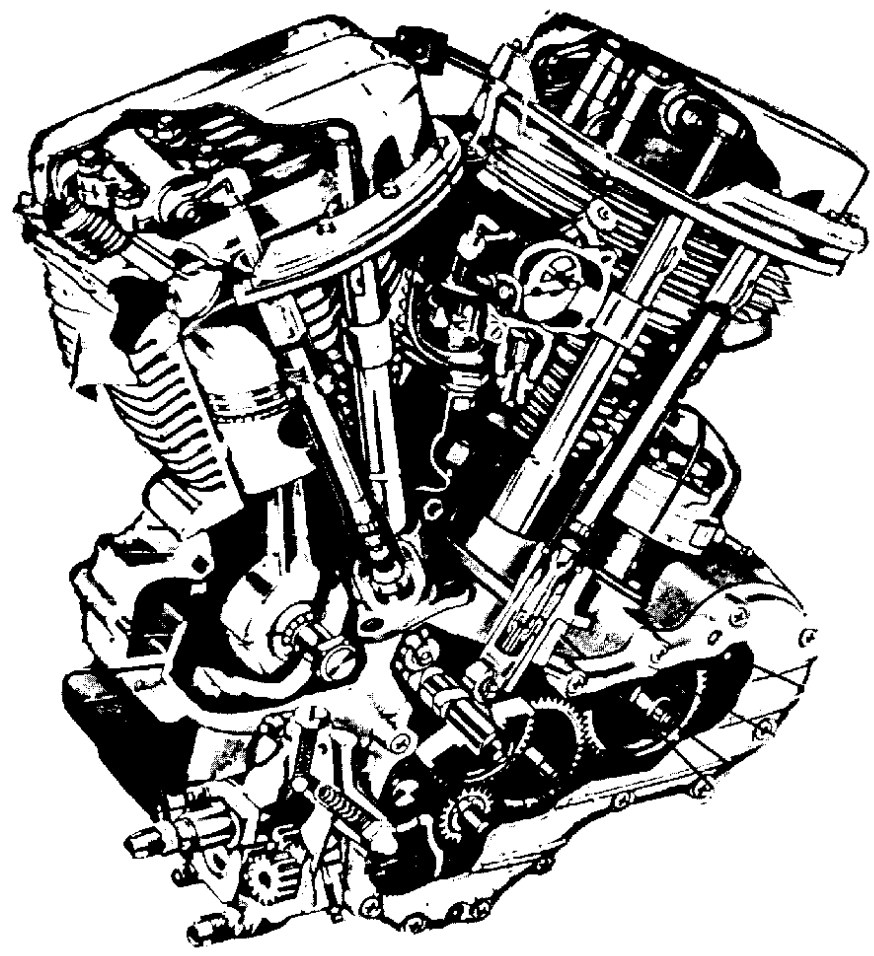



# SHOP DATA:

## VALVE GUIDES -- 1948 AND LATER O.H.V. ENGINES

New engines are assembled with steel intake valve guides and bronze exhaust valve guides, however, only bronze guides are furnished on parts order for both the intake and exhaust valves.

Until recently valve guides have been furnished in standard size and .001" and .002" oversize only. The guides were unmarked except for marking on carton.

When guides first became available in five sizes, standard size, .001", .002", .003" and .004" oversize, the only marking to identify size of guides was the part number stamped on carton. Later on, oversize guides were identified by numerals (1 to 4) stamped on guide, indicating the oversize. At the present time oversize guides are identified by grooves (1 to 4) cut in top end of guide, indicating the oversize.

Standard size guide is not marked for identification. If in doubt whether or not a guide is standard size, measure it -- standard size guide measures .5655".

# SHOP DATA:

## EXHAUST VALVE ROTATING MECHANISM

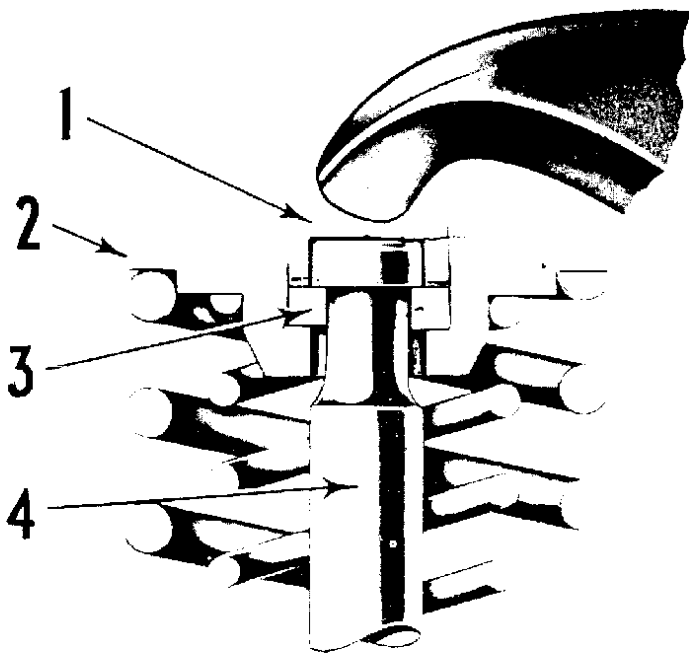

1. Valve Stem Cap (Part No. 18234-52)
2. Valve Key (Part No. 18230-52)
3. Spring Collar (Part No. 18221-52)
4. Exhaust Valve Stem (Valve Part No. 18081-52)

Starting with engine No. 52FL3910 a different type exhaust valve went into production. The new valve in open position is free to rotate, and there is less possibility of valve head warping and burning. Engines will give a longer period of service without valve reseating.

Valve rotating mechanism functions as follows: Valve stem cap, item 1, has slight clearance between end of valve stem and seats against valve key, item 3. When rocker arm applies pressure against valve stem cap, valve key is moved away from valve stem shoulder and valve is free to be rotated by the escaping exhaust gases.

**CAUTION:** Applying to an engine fitted with exhaust valve rotating mechanism, be very careful when there may be an occasion to remove push rods, especially so if they are to be pried out. Unless exhaust valves are allowed to seat gradually, rather than snap back against valve seats, valve stem cap, item 1, may be thrown off end of valve stem.

If assembled heads fitted with exhaust valve rotating mechanism are turned upside down valve stem cap may drop off valve stem. If valve stem cap falls off and is not replaced it can get wedged between the valve spring coils, or it may block oil return channel.

Valve with its rotating mechanism can be used as a replacement exhaust valve in any 1948 and later overhead valve engine. A valve kit is available under Part No. 18083-52. Kit includes valve stem cap, item 1; valve spring collar, item 2; valve key, item 3; and exhaust valve, item 4. Kit is used with standard valve springs.

# SHOP DATA:

## VALVE SPRING TESTING INFORMATION

The information in this bulletin is to be used as a guide in replacing intake and exhaust valve springs which have weakened or "taken a set" due to excessive heat and extended service in the engine. Valve springs which are too weak will not close properly at high speeds causing erratic engine operation, and probable damage to the valve, valve guide and seat.

The following table lists valve spring testing specifications for new valve springs applying to all Harley-Davidson 4-cycle engine models. To use the information listed when testing springs, a valve spring compression testing device is needed which will compress the spring the specified distance and at the same time measure the pounds compression. It is recommended that Harley-Davidson Valve Spring Tester and Torque Wrench, Part No. 96797-47, be used for this purpose.

### VALVE SPRING SPECIFICATIONS

MODEL	PART NO.	FREE LENGTH	VALVE CLOSED		VALVE OPEN	
			COMPRESSED LENGTH	POUNDAGE	COMPRESSED LENGTH	POUNDAGE
1941 and later 45 Side Valve (except K Model)	18201-41	2-19/32	2-3/16	50 to 60	1-7/8	90 to 100
1930 and later 74 & 80 Side V.	18200-30	2-7/16	2-1/8	55 to 65	1-3/4	125 to 135
1936 and later 61 & 74 O.H.V. (except FLH)	18203-36 (outer)	1-13/16	1-13/32	55 to 65	1-1/16	110 to 120
	18204-36 (inner)	1-15/32	1-1/4	25 to 35	29/32	70 to 80
1955 and later FLH Model 74 O.H.V.	18203-36 (outer)	1-13/16	1-3/8	105 to 115	1.00	180 to 190
	18202-57 (inner)	1-23/64	1-3/16	25 to 35	51/64	70 to 80
1952 and 1953 45 Side Valve (K Model)	18201-52	2-15/32	47 to 57	47 to 57	1-7/8	120 to 130
1954 to 1956 55 Side Valve (KH Model)	18200-32	2-15/32	1-15/16	47 to 57	1-19/32	120 to 130
1957 and later 55 O.H.V. (XL, XLH Model)	18203-57 (outer)	1-1/2	1-9/32	52 to 62	15/16	155 to 165
	18204-57 (inner)	1-23/64	1-3/32	30 to 35	3/4	75 to 85

Recommendation: A used valve spring testing 5 pounds or more below low limit poundage shown in table should be replaced with a new spring.

VALVE SPRINGS - FLH MODEL

Starting with engine number 57FLH-4444, all Model FLH engines shipped from the factory have new, stronger valve springs. Also, these new springs are now being supplied on parts order for replacement requirements applying to earlier FLH engines.

Because of the higher valve spring poundage obtained with the new springs, better valve following at high engine speed results. Therefore, on earlier FLH engines, when faulty valve action is suspected as the cause of substandard engine performance at high engine speed, we recommend replacing old valve springs with new type springs.

Use the following chart as a guide for ordering and using Big Twin OHV valve springs.

	Outer	Inner	
New Spring (Stronger Type) Part No. →	18201-57	18202-57	Note: New stronger springs are identified by aluminum paint on coils.
Use For FLH Model			
Old Spring (Standard Type) Part No. →	18201-57	18202-57	
Use For FL and EL Models			

Note:

The following points should be observed in connection with any valve spring replacement on FLH engines.

1. If exhaust valve guides are found to be bronze guides, replace with new steel guides as recommended in Shop Dope Bulletin No. 382.
2. If exhaust valves have run considerable mileage or have been running for some time with a very loose guide fit, it is advisable to replace with new valves.
3. If either valve guides or valves are replaced, reface valve seats only as much as necessary to produce unbroken seating surface between valve face and seat.

# SHOP DATA:

---

## SERVICE INFORMATION ON HYDRAULIC TYPE PUSH RODS WITH WHICH ALL 1948 OVERHEAD VALVE ENGINES ARE FITTED.

Here is complete service information on hydraulic type push rods applying to all 1948 overhead valve model engines.

The instructions which follow under the heading, "Push Rods and Valve Tappets" will be published in the new Rider's Instruction Book now being printed. As you will note from these instructions, riders will be told tappets of these engines do not require periodic adjustment and no information is given riders about adjusting tappets nor hydraulic push rods.

The instructions given under the heading, "Adjusting Tappets of 1948 Overhead Valve Engines, Which Are Equipped with Hydraulic Type Push Rods" explain how to make this adjustment when necessary, and the instructions under the heading "Servicing Hydraulic Push Rod" explain servicing procedure. These instructions are intended for and are being sent only to our dealers for their own use and for the use of their mechanics.

**NOTE:** Since the Rider's Instruction Folders which are being included with new motorcycles until the new books are ready, make no reference to the 1948 hydraulic type push rods and tappets, it will be well for you to pass along to those who purchase 1948 overhead valve models in the meantime, the rider information contained in this bulletin.

### PUSH RODS AND VALVE TAPPETS (Rider Information)

Push rods are self adjusting, hydraulic type. They automatically adjust their length to compensate for hot engine expansion and valve mechanism wear, and thus keep the valve mechanism free of lash when engine is running. Tappet adjustment is required only in new engine assembly, and when engine is reassembled after repair, to compress the push rod hydraulic units to the length specified for normal functioning. No further readjustment of tappets is required.

On starting an engine, which has been shut off even for a few minutes, the valve mechanism may tend to be slightly noisy until the hydraulic push rod units completely refill with oil. If at any time, other than for a short period immediately after engine is started, valve mechanism becomes abnormally noisy, it is an indication that one or more of the hydraulic push rod units may not be functioning properly. Always check the lubricating oil supply in the oil tank first, if the valve mechanism becomes noisy, since normal circulation of oil through the engine is necessary for proper operation of the hydraulic units. If there is oil in the tank, the push rod units may not be functioning properly due to contamination in the oil supply. Drive at moderate speed to the nearest Harley-Davidson Service Station for further attention.

---

## ADJUSTING TAPPETS OF 1948 OVERHEAD VALVE ENGINES

(Dealer and Mechanic Information)

Engine must be cold.

Remove push rod cover keepers and telescope covers to expose tappets.

Before readjusting a tappet, make sure it is at its lowest position. You can make sure of this by turning engine in the direction in which it runs until the like tappet (intake or exhaust) in the other cylinder is at its highest position (valve fully open).

Loosen tappet adjusting screw lock nut and turn tappet screw down until push rod is free and has noticeable shake. When checking for push rod shake, grasp push rod with finger tips just below cylinder head, and shake toward front and rear of engine.

Slowly turn tappet screw upward just far enough to take up all push rod shake. Now, mark tappet screw with chalk or in some other manner, so its turns can be accurately counted, and then continue turning it upward exactly three full additional turns.

Adjust the other three tappets the same way.

With tappets accurately adjusted according to above instructions, hydraulic units will be compressed  $3/32$ " which is the specified setting for normal functioning.

If, after readjusting tappets, engine does not start readily because of loss of compression in one or both cylinders, allow engine to stand a few minutes before further attempt to start. This standing time is required to allow the newly adjusted hydraulic units time to leak-down until valves are fully seated.

Bear in mind that after initial tappet adjustment as described above, hydraulic type push rods are self-adjusting to compensate for hot engine expansion and valve mechanism wear. Therefore, tappet adjustment is normally required only in new engine assembly and when engine is reassembled after having been taken apart for repair.

## SERVICING HYDRAULIC PUSH ROD (Dealer and Mechanic Information)

Servicing push rod consists only of removing it from engine, disassembling hydraulic unit, washing the parts thoroughly, and reassembling.

There are two principal parts of the hydraulic unit. These are the plunger (3), and the cylinder (7). The plunger contains the check valve assembly, which is held in position by the plunger spring (6). It is recommended that only one unit at a time be taken apart for servicing, and that it be reassembled before working on any other unit, as plunger and cylinder are selectively fitted by the manufacturer to the clearance required to allow a definite leakage rate between plunger and cylinder. Plunger or cylinder of one unit must not be interchanged with plunger or cylinder of another unit. Neither the plunger nor the cylinder will be supplied separately on parts order for replacement purposes. Where either part is found in bad order, install a complete new hydraulic unit.

As the hydraulic unit cylinder is a press fit into push rod, it will be necessary to service unit without removing from push rod. Where it may be found that a complete unit must be replaced, cylinder can be forced out of push rod and a new unit pressed or driven in.

In disassembling the hydraulic unit, first remove snap ring (1) which is located at top of cylinder; then remove plunger from cylinder. In case plunger does not pull out of cylinder easily, grip top of plunger with a pair of pliers wrapped with tape, and pull with a twisting motion.

During the disassembly operation it is advisable to hold the hydraulic unit over a pan of clean solvent in which the parts are to be washed, or at least over a bench, so check valve parts will not become lost. After removing plunger, disassemble check valve parts (4) and (5), and wash all parts thoroughly.

After parts have been thoroughly washed, test the hydraulic unit to determine if check valve is holding, and also whether leakage past the plunger is still normal. This can be done as follows: (Do not oil any parts when making this test.)

Assemble ball (4), retainer (5) and spring (6) back into plunger; then, holding plunger in upside-down position so that ball falls into its seat, start cylinder onto plunger. Quickly push cylinder down over plunger and immediately release it. If unit is in good order and check valve is holding, cylinder should bounce back.

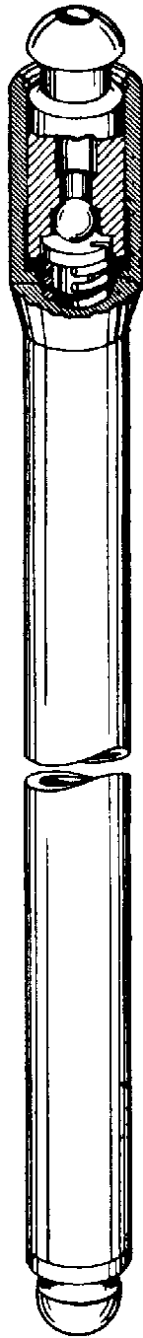
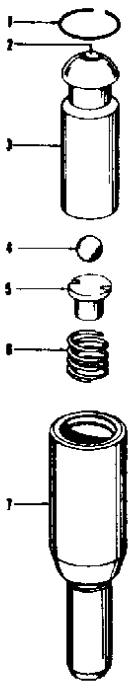

### PUSH ROD HYDRAULIC UNIT

1. Plunger retaining snap ring
2. Oil inlet hole
3. Plunger
4. Ball check-valve
5. Ball retainer
6. Plunger spring
7. Cylinder

If when cylinder is quickly pushed down and immediately released, it stays down, either the check valve is leaking, or cylinder and plunger are worn to the extent that there is excessive leakage past plunger. In order to determine whether check valve is leaking, place a finger over hole (2) at the end of plunger, and repeat the test operation. If the cylinder now bounces back as it should, it is an indication that the check valve is leaking, possibly due to parts still being dirty. Re-wash parts thoroughly and repeat the test operation. If the cylinder still does not bounce back, the complete hydraulic unit should be replaced with a new one.

If the above described test shows the unit to be functioning normally, complete re-assembly by installing snap ring (1), making sure that it seats in its groove near the top of cylinder.

If a serviced push rod is to be used immediately it is not necessary to re-oil the hydraulic unit before assembling push rod in engine. The engine oiling system will re-oil the unit as soon as engine is started.

After reassembling push rod in engine, be sure tappet is accurately readjusted according to tappet adjusting instructions in this bulletin.

A newly serviced hydraulic unit may be noisy for several minutes after engine is started, as some time is required to work out all the air and fill unit with oil. Time interval between starting and quieting may vary from a few minutes to as much as thirty minutes.



## SCREEN AND CHECK VALVE IN OIL PASSAGE TO OVERHEAD FITTINGS AND HYDRAULIC PUSH RODS

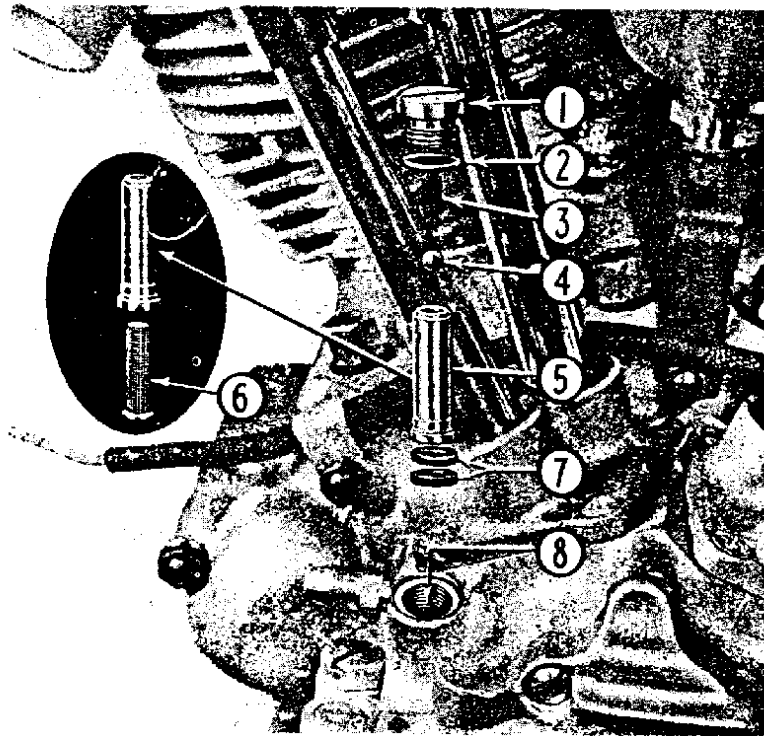

1. Cap Screw (Part No. 24987-52)
2. Cap Screw Gasket (Part No. 24994-52)
3. Check Valve Spring (Part No. 24992-52)
4. Check Valve Ball (Part No. 8856)
5. Screen Housing and Check Valve Ball Seat (Part No. 24985-52)
6. Screen Assembly (Part No. 24975-52)
7. Cork Seals (two) (Part No. 24990-52)
8. Crankcase Well for Screen Assembly

hook in crankcase well (8) engage it with one of the holes (see illustration) in housing (5) and pull housing out of well. Be careful that you do not lose check valve ball (4).

With a pointed instrument engaged in hole in base of screen assembly (6), turn the assembly so notch lines up with key in housing, and remove screen. After cleaning or exchanging screen reinstall it in housing and secure it by turning so that engaging notch is approximately  $180^{\circ}$  from housing key.

It is not necessary to remove or renew the cork seals (7) every time screen is removed for cleaning or replacing unless they show signs of being damaged. If they are removed for any reason, care must be exercised when installing that they be fully seated in bottom of crankcase well. In no case install more than two seals. More than two seals will block the oil passage from well to overhead fittings.

**Note:** As mentioned above, at any time push rod operation becomes erratic, the screen should be removed and cleaned - also oil pump pressure should be checked with a pressure gauge attached to oil pump. The screen should be removed and cleaned first.

Starting with engine number about 52FL3529 (can also be identified by boss and cap screw at the side of rear tappet guide) a screen and check valve were incorporated in the oil passage leading to overhead fittings and hydraulic push rod units.

The purpose of the screen (6) is to keep foreign matter from entering the hydraulic push rod units.

The purpose of the check valve ball (4) is to prevent oil in the overhead passage from draining back when engine is not running, thus maintaining a head of oil, so push rod hydraulic units that have leaked down under open valve load will fill quickly when engine is started.

At the time of every oil change (at intervals not exceeding 2000 miles) or at any time hydraulic push rod operation may become erratic, screen should be removed and thoroughly flushed and cleaned, or better still, discard it and replace with a new screen.

To remove screen first remove items 1, 2 and 3; then bend one end of a piece of wire to form a hook about  $1/16$ " long. Insert

# SHOP DATA.

## VALVE OPENINGS - ALL MODELS

1937-47 OHV	.343
1937-48 B.T. Side Valve	.375
1937-55 WL	.312
1948-52 61 OHV	.343
1948-56 74 OHV	.368

Cam lift on 1948 —  
Later B.T. = 1½ to 1

Started use 61 cam - Engine # 48 EL 5258

## VALVE SEAT WIDTHS

OHV	.0672
UL	.154

When grinding valve seats use stellite stone with steady flow of kerosene. This prevents clogging of stones.

Standard guides measure .740/.732. When using H.L. Cam guides should measure from Collar to Base .692/.700.

## VALVE ADJUSTMENT

On bench job. Adjust valve between rocker and valve end to .045 with oil free engine.

Oil dripper should have 3/32" clearance from inner edge of dripper to rocker arm end.

## FOR CORRECT VALVE ADJUSTMENT ON ENGINE RUNNING;

Adjust valve until engine begins to miss and back off two complete turns.

## ROCKER ARM SHAFT CLEARANCE

Use .002 or .003 paper to check on rocker shaft. Surface grind faces of rocker housings and then assemble and lap with 7/8" bar or sunnin hone (to proper fit).

Rocker stud height 1 15/32".

High speed lifter leakage caused by head gasket leak close to oil feed hole. 1948- 52 models.

## FOR ENGINE OVER - OILING

Leave on side stand at lowest idling speed for 15 minutes (Engine will not overheat). Remove manifold and check for oil in inlet port hole. If oil fills or collects in port the trouble is caused by oil dripper on intake rocker. Clearance for new drip tube is 3/32" to rocker arm end.

## OIL PRESSURE CHECK - ON 1952 AND LATER

Make oil tappit strainer solid around the upper holes. This checks oil pressure in the bottom end. If this checks OK, check cylinder one at a time by blocking off oil feed passage between cylinder and cylinder head.

## OIL PUMP Maximum oil pressure with oil at hot operating temperature.

Part #	Check Ball Dia.	Spring Free Length	Oil Pressure	Model	Adjustment
713-36	23/64"	1 11/32"	6 to 8 lbs.	1936 to 1939 OHV	3/8" from outer surface
26371-37	25/64"	1 5/8"	14 to 16 lbs.	37 to 40 SV	open 9 turns from bottom
713-39	25/64	1 25/32	19 to 22 lbs.	1940 SV	open 9 turns from bottom
713-39	25/64	1 25/32	14 to 17 lbs.	1940 OHV	3/8" from outer surface
26374-36	25/64	1 31/32	30 lbs.	1941-51 OHV	3/8" from outer surface
26371-41	3/8	2 1/16	35 lbs.	1940 & later OHV	3/8" from outer surface
26374-52	25/64	1 31/32	30 lbs.	1952 & early 54 OHV	no adjustment
26374-52	25/64	1 31/32	7 to 10 lbs.		solid plug
26374-54	21/64"	2 3/8"	30 to 35 lbs.	Late 54 thru 57 OHV	Discard regulating valve & use.
					No adjustment



### Servicing Oil Pump (O.H.V. Engine)

(To Identify Items, Refer to Illus. 56)

Oil feed pump and scavenger (oil return) pump are gear type pumps incorporated in one pump body. Feed pump incorporates an automatic (centrifugal) by-pass valve, reducing oil feed supply at low engine speeds and increasing supply at high engine speeds. Pump is provided with check valve (11) and adjustable pressure regulating valve (16). Maximum pressure is approximately 30 pounds per sq. in.

Thoroughly clean exterior of pump in gasoline or cleaning solvent before disassembling.

With cover (29), governor rotor (28) and cover plate (26) and gasket (27), already removed, scavenger pump gears (wide gears) (22) and (23) are exposed. Scavenger pump gear (23) is keyed on pump drive shaft (8) and idler gear (22) idles on stud in pump body.

Remove lock ring (24) from end of pump drive shaft and slide gears off shaft and stud respectively. Remove scavenger pump gear key (21) from pump drive shaft.

ILLUS. 56  
OIL PUMP DISASSEMBLED (O.H.V. ENGINE)

Drive shaft can now be pulled out of pump body. Oil feed pump gears (narrow gears) (5) and (6) are now free for removal, however, gear (6) may come out with drive shaft. Remove drive gear key (7) from drive shaft.

Remove chamber cap screws (9) and (13), adjusting screw (14), springs (10) and (15) and valves (11) and (16).

Remove front chain oiler adjusting screw (17) and adjusting screw washers (18) and (19). If pump is fitted with rear chain oiler, remove adjusting screw and adjusting screw washers.

Clean all parts in gasoline or cleaning solvent and blow out all pump body passages with air.

Using a light, inspect valve seats in pump body for pits and for dirty condition. Note: A small particle of foreign matter lodged on valve seat will prevent valve from seating, thus preventing correct operation of pump. Replace pump body if seats are damaged.

Inspect springs for breakage and rusted condition. Replace if not in good condition. Free length of new pressure regulating (by-pass) valve spring (15) is approximately 1-31/32".

Check valve spring (10) is the same for all pumps but is not interchangeable with any pressure regulating (by-pass) valve spring. It is much lighter (has less tension) than pressure regulating (by-pass) valve spring. Free length of check valve spring is approximately 1-9/32".

Valves (11) and (16) are interchangeable for check valve or pressure regulating (by-pass) valve and are the same for all pumps. Valves may have rings formed by action on valve seats. Valves not perfectly smooth and round should be replaced.

Governor rotor (28) and rotor chamber in pump cover (29) ordinarily show no appreciable wear, and very seldom need replacing. **1948 pump only**

Make sure that all parts and valve seats and all passages in pump body are thoroughly clean and free from dust, dirt, or grit before assembling. Also make sure valve in governor rotor (28) works freely, as a sticking valve will likely result in over-oiling at lower speeds.

Install check valve (11) and spring (10) and secure with cap screw (9). Install pressure regulating (by-pass) valve (16), spring (15), and adjusting screw (14), turning in adjusting screw until end of screw is 3/8" below end of valve chamber. This is normal setting. See "Adjusting Oil Feed Pump."

To complete assembling of oil pump reverse procedure followed in disassembling. Note that one of the three gear keys, (7), is smaller than other two—install this key in shaft for oil feed pump gear (6) (narrow gear).

Some pumps may have a thin (.003") spacer behind scavenger pump idler gear (22) and gear will be .497" wide. Other pumps will have no spacer behind

scavenger pump idler gear and gear will be .500" wide. A gear .497" wide should be used with spacer but a gear .500" wide must not be used with spacer. To exceed a total of .500" for width of idler gear and thickness of spacer may cause gear to bind tight enough to result in serious damage to pump.

Note: If scavenger idler gear has a groove on one side starting between two gear teeth and extending nearly to stud hole, install it on stud with grooved side against pump body. If scavenger idler gear has a groove across stud hole and in line with gear teeth, install it on stud with groove side outward. Parts order scavenger idler gear has both the grooves just mentioned, one on each side; is .497" wide and can be installed in any O.H.V. Model scavenger pump.

If pump is fitted with rear chain oiler, install scavenger pump gear (23) on drive shaft with groove (between two gear teeth) outward.

Lock rings (1) and (24) are often damaged when removing them, therefore, it is advisable to install new ones when reassembling and installing pump. Make sure lock ring is securely engaged and seated in retaining groove.

## Installing Oil Pump (O.H.V. Engine)

(To Identify Items, Refer to Illus. 56)

Examine pump gaskets closely. If they are in good condition they can be re-used. If condition is at all questionable, install new "factory-made" gaskets. Never use "home-made" gaskets because these gaskets have holes especially located for oil passages and if a hole is left out or put in wrong place, oiling system may be put completely out of commission. With pump assembled (except pump cover, rotor and cover plate) and pump body gasket (4) in position against crankcase, enter pump drive shaft in bushing in crankcase and mount pump on studs.

Install drive gear key (3) in shaft keyway, and install drive shaft gear (2) and lock ring (1). Use new lock ring and make sure it is securely engaged and seated in retaining groove. Insert flat head screw (20) and tighten securely. Note: Before installing drive shaft gear (2), install bearing oil seal ring (33) shown in Illus. 62.

Install cover plate gasket (25), cover plate (26), and cover gasket (27).

Install oil governor rotor (28) in pump cover (29). Start cover on mounting studs, turn pump drive shaft slowly and press lightly against cover until driving tongue on rotor (28) registers in slot in scavenger idler gear.

Install nuts (31) and (32) and lock washers on pump mounting studs, insert hexagon head screw (33) with washer and tighten nuts securely. Note that extension nut (32) is placed on left center stud.

Turn pump drive shaft and note whether or not it turns freely. If there is considerable bind, check pump to determine cause.

# SHOP DATA:

## SERVICING 1948 OVERHEAD VALVE ENGINES FOR BEST OIL CONTROL AND OIL MILEAGE

Anything above 250 miles per quart of oil is considered normal oil mileage. In any case where oil mileage may be reported considerably below 250 miles per quart don't jump to the conclusion that piston rings or cylinder bores or both are in bad order, and that the reported heavy oil consumption must be due to excessive oil passing rings into the combustion chambers and out with the exhaust. There are other reasons for abnormal oil consumption.

Before taking any action get a complete case history. If the report claims heavy exhaust smoke and possibly repeated plug fouling, and your observations and tests confirm this, there is no further question but what, for one reason or another, excessive oil is passing through one or both combustion chambers, and an engine top end job will have to be done to determine why. If there is no evidence of heavy exhaust smoke or plug fouling, but nevertheless you confirm the report of oil mileage considerably below normal, it may be due to one or more of the conditions described in the following three paragraphs, in which case engine probably will not need to be opened up for internal inspection.

Maybe front chain oiler is adjusted to feed an excessive amount of oil, and possibly motorcycle has also been equipped with a rear chain oiler as supplied by various accessory producers. A combination like this, set for excessively heavy feed, can account for as much as 50% of the oil used.

Possibly oil pump check valve ball is not seating perfectly, and oil is being lost to the outside through breather when motorcycle is standing for any length of time.

Possibly considerable oil is being wasted due to a leak somewhere about engine as a result of a sandhole in one of the castings, a broken or damaged gasket or push-rod cover seal, or loosened fittings.

Where investigation proves that low oil mileage is due to an excessive amount of oil passing through combustion chambers and out with the exhaust, proceed as follows with an upper end job.

1. When removing cylinder heads, carefully inspect head gaskets around the holes that match the oil passages that feed oil to the overhead fittings, and drain back the discharged oil. If you find a break or furrow between one of these holes and the inside diameter of gasket, this alone is enough to account for excessive oil consumption, plug fouling, and heavy exhaust smoke. Unless gaskets are in perfect condition and form a perfect seal around these holes, the combustion chamber of the cylinder involved will be flooded with oil. Also examine cylinder head joint face around these holes. If the joint face between one of these holes and combustion chamber has been nicked or deeply scratched, the result will be the same as with gasket damaged as described above.

Also examine cylinder base gaskets as cylinders are removed. Observe whether or not gaskets are in good order around the hole punched for oil passage up the right side of cylinders. A break in base gasket from this hole inward is likely to result in the oiling system running lower than normal pressure, and an over supply of oil in crankcase.

2. Remove cylinder head covers and make a close inspection of rocker arms. Observe particularly that welch plugs (one in each end of arm) are securely in place. If an arm is found with a welch plug out, be sure to find the plug, as it may be lodged somewhere in the oil return channel down the left side of head and cylinder. Unless found and removed, it will probably eventually shift into a position where it completely blocks the return channel. In this case the cylinder head will be flooded with oil, and the job of removing cylinder will have to be done over again in order to remove the obstruction. Where a welch plug has come out of place, it can be reinstalled by soldering or brazing. A welch plug that appears to be even slightly loose should be treated in the same manner; as a missing or badly leaking welch plug will drop overhead oil pressure so low, especially when oil is hot, that pushrod hydraulic units will become noisy. Part numbers covering rocker arm welch plugs are: Large plug 109-48A, Small plug 109-48. (Latest rocker arms which went into new assembly near the end of the 1948 season have no welch plugs. Only one end of the arm requires plugging, and a solid, drive fit plug is installed. Only rocker arms of this construction are now supplied on parts order.)

Also inspect rocker arms for loosened or broken pushrod ball socket. A ball socket in bad order may also bleed away enough oil so that pushrod hydraulic units do not get the oil required for normal quietness of operation. (The pushrod ball socket has been so changed and strengthened that there will probably be little if any breakage in the future. This item is still not supplied on parts order, even though it is listed in the parts catalog. There will be further word at a later date in regard to the possibility of dealer servicing of arms with broken or damaged ball socket.)

3. The next step is checking cylinder heads for possible oil leak from the top of head into the intake port. There is considerable oil discharged from overhead fittings onto top of head, and if there is a leak through the head into the intake port, due possibly to a loose valve guide or a sand hole, some of this oil will be sucked through into inlet port and combustion chamber. Enough will be sucked through to cause plug fouling, heavy exhaust smoke, and to drop oil mileage way below normal. In other words, the result will be the same as if rings and cylinder bores were in bad order. This check should be made by applying air pressure to intake port and at the same time applying gasoline or solvent to top of head around valve guide and the surrounding area above inlet port. If there is a leak around valve guide or elsewhere it will be indicated by bubbles. Even the slightest leak found must be corrected. If there should be a leak around inlet valve guide, due simply to guide fitting loosely in head, it probably can be serviced satisfactorily with an oversize guide. Oversize valve guides are listed in parts catalog. If, however, it is found that guide hole in head is out of round, there is no satisfactory repair. When a new oversize guide is installed to replace one found with a leak by it, repeat the air test after new guide is installed, even though it does seem to drive in with a normally tight fit. If hole in head is out of round, guide may drive in tight, but still have a leak by it. A sand hole through head into intake port can usually be repaired with low temperature welding material.

A set of fittings with which a dealer can make a quick air pressure check for inlet port leakage is in the making, but not yet available. As soon as these fittings are available, you will be advised through a supplementary bulletin. In the meantime you can devise a temporary means of making this check. All you need is a plug or cork of a size to fit cylinder head inlet nipple. The plug must have a small pipe installed through it, so that air pressure can be applied. With inlet valve assembled and plug pushed tight into inlet nipple, apply air pressure and at the same time apply gasoline or solvent to the top of head around valve guide.

The exhaust valve guide should also be tight in head. However, if there happens to be a minor leak by it, there would be little if any effect on oil consumption.

4. Next check cylinder bores and pistons for size and general condition. If it is found that cylinder bores are not enlarged enough, due to wear, to require refinishing oversize, make another extremely close inspection of the bore of each cylinder to be sure that the ring path is smooth and polished as it should be, with only minor up and down scratches where the piston thrust faces take bearing against cylinder bore. If the ring path in one or both cylinders has a dull, lapped appearance, this indicates that there are probably a multitude of fine scratches the length of ring path, all around the bore, as a result of ring scuffing. If this condition exists, bore should be refinished oversize. Simply re-ringing a scratched bore, even though the new ring set includes the most effective type of oil ring, is not likely to effect a satisfactory oil seal. Bear in mind that there is a difference between scored cylinder bores and scratched bores. Scoring, which results from high speed or overheated operation, is damage that can't be overlooked and leaves no choice about refinishing. Bore scratching to the extent of excessive oil passing, even with new rings, is not so readily observed. Take no chances on cylinder bore condition. Unless the bore is unquestionably smooth and shiny, except for minor streaks or scratches where piston takes bearing against cylinder bore, re-finish.

5. The new piston ring combination to be used on each piston is two No. 265-48 compression rings for the 61 O.H.V. or two 265-41 compression rings for the 74 O.H.V. A new type vented oil ring is to be used, Part No. 22374-49 for the 61 O.H.V. or Part No. 22364-49 for later 1948 74 O.H.V. Since the new type oil ring is 3/16" wide it cannot be used on the earlier 1948 - 74 O.H.V. piston, because that piston had an oil ring groove only 1/8" wide. Later 1948 - 74 O.H.V. pistons have oil ring groove 3/16" wide. This change went into production with engine No. 48FL 10184. All parts order pistons now furnished for the 1948 74 O.H.V. of course, have the wider oil ring groove.

When servicing an early 1948 - 74 O.H.V. equipped with pistons with 1/8" oil ring groove, which are still in condition for further use, use vented oil ring 266-41A, which is 1/8" wide.

All of the piston ring numbers shown above cover standard size rings. In the future when pistons or rings are ordered, according to information in Parts Department letter of July 12, covering pistons and rings for 1948 O.H.V. models, instead of furnishing four rings, all alike, per piston, the new combination of two compression rings and one 3/16" wide vented oil ring per piston will be furnished.

For sometime the 3/32" wide compression rings furnished for 1948 overhead engines (also apply to earlier than 1948 74 O.H.V.) have been bevel backed rings. One side of ring has the inner edge beveled. This side of ring is or should be marked "TOP". This type of ring must be installed in piston with the beveled edge upward, whether or not that side is marked "TOP". If installed with beveled edge downward, this type of ring becomes an oil pumper.

6. The next step is to convert the oil pump as follows:

#### PUMP CHANGES

It is not necessary to remove complete oil pump from engine in order to make these changes. Refer to 1948 Big Twin parts catalog, page 23. Remove pump cover and governor rotor part Nos. 682-41 and 687-41C, and also remove cover plate No. 683-41. Discard governor rotor and cover plate. Install new cover plate 683-49. You will note that new cover plate blocks off the holes in pump body and cover that formerly passed oil to and from the governor. (If a new cover plate 683-49 is not available when it is desired to make this pump change, use the original plate after securely plugging these holes. After plate and gasket are installed replace pump cover.

Remove and discard pump check valve spring 703-48, and replace it with check

valve spring 703-36, which is a much lighter spring. 703-36 is the same check valve spring used in 1947 and earlier oil pumps.

With the above described changes made in the oil pump, oil pressure builds up much faster from low speed, and considerable more oil is circulated through engine while idling and operating in the low speed range. This explains the ring change from a moderate to a vented oil control ring.

7. When servicing an engine as outlined above, if piston rings were found badly worn and scuffed, and cylinder walls also scratched and scuffed, don't fail to thoroughly flush out engine base, timing gear case, and oil tank before re-assembling and putting engine back in service. Where there is undue piston and cylinder wear, the engine oil becomes contaminated with fine particles of metal. Unless a newly serviced engine is put back in use with clean, fresh oil, free of metal particles and other contamination, undue wear is again likely to be experienced. Even an engine that appears quite clean, and with little, if any ring and cylinder bore wear, should at least have the oil tank drained, flushed, and refilled with fresh oil before putting back in use.

8. When re-assembling cylinders and heads, apply gasket sealer to all gaskets. If the head cover gaskets you have available are only about 1/32" thick, use two per head, if approximately 3/64" thick use only one gasket. Only the later 3/64" thick cover gasket is now used in new production and supplied on parts order.

9. Install spark plugs with the latest 7/8" outside diameter plug gasket, especially if there has been seepage of oil between cylinder head and spark plug insert. The new larger gasket will seal any leakage at this point, as it is large enough to overlap the insert and seal against head surface. Gasket part No. 32342-42.

Order needed oil pump conversion kits (new cover plate and check valve spring) under Part No. 583-49A. This kit will be furnished no charge. Order only a few at a time as needed for short period requirements, as at present these parts are available in limited quantity.

---

While all of the later 1948 O.H.V. engines were fitted with four rings per piston, a few of the last O.H.V.'s shipped at the end of the '48 season, had oil pump converted. A list giving the number of these motorcycles is attached hereto.

---

It is also permissible in the case of any 1948 O.H.V. engine that is running normal or above normal oil mileage to convert oil pump. If, however, an engine is already over oiling as evidenced by low oil mileage, heavy exhaust smoke, and plug fouling, just converting the oil pump but doing nothing else is likely to make matters worse. When an engine is already over oiling through combustion chambers, it should be serviced as outlined above before converting oil pump.



# SHOP DATA

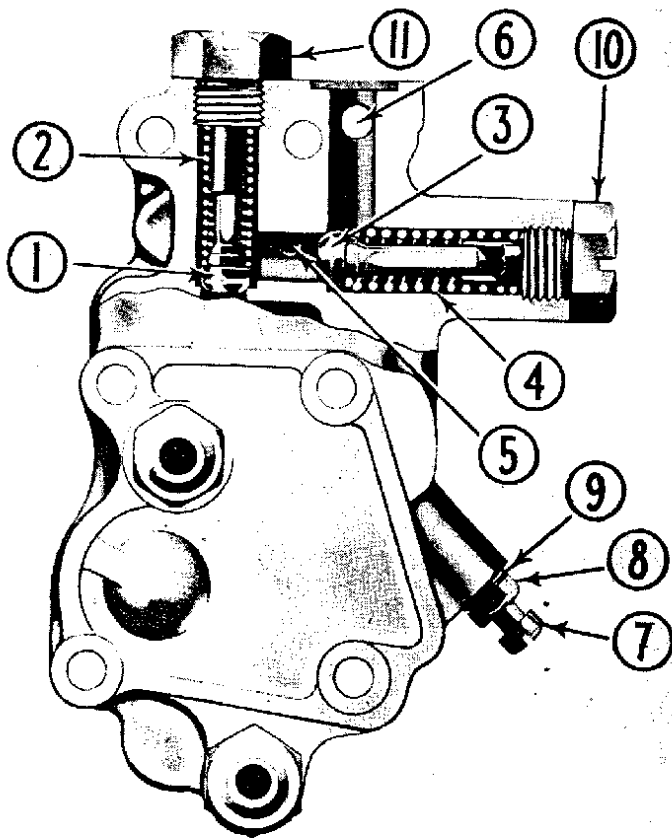

## LATEST O.H.V. OIL PUMP

The oil pump used on later 1952 model O.H.V. engines differs somewhat in construction from the earlier pump, although as complete units they are interchangeable.

The valves have been redesigned to effect more positive seating.

Only the latest pump is now supplied for parts order requirements for 1948 and later engines.

The later pump has no provision for re-adjusting oil pressure, this being predetermined in design. Maximum pressure is about the same as with the earlier pump.

1. Check Valve—same as item 3 (Part No. 26400-52A)
  2. Check Valve Spring (Part No. 26363-36)
  3. Regulating Valve — adjustable—see item 1
  4. Regulating Valve Spring (Part No. 26374-52)
  5. Feed Oil Passage—to timing gear shaft and lower connecting rod bearings
  6. By-pass Oil Passage—to timing gear case
  7. Front Chain Oiler Adjusting Screw
  8. Front Chain Oiler Adjusting Screw Lock Nut
  9. Front Chain Oiler Adjusting Screw Washer
  10. Regulating Valve Guide—same as item 11 (Part No. 26423-52A)
  11. Check Valve Guide—see item 10
- } Sold as kit  
} Part No.  
} 26383-32

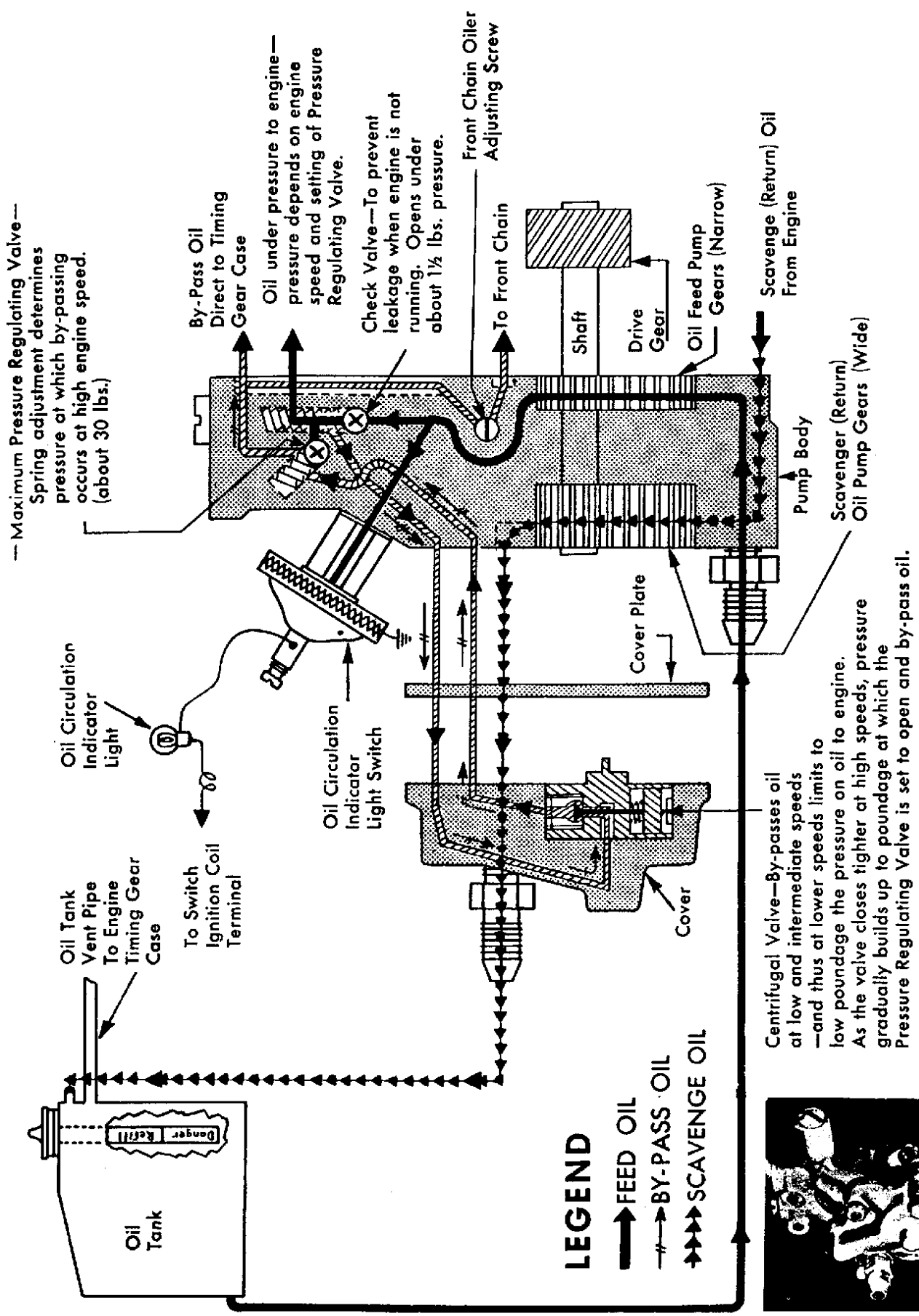

**SCHEMATIC DIAGRAM OF OIL PUMP FOR 1948 61" & 74" O.H.V. MODELS.**

ILLUS. 23



1948 - 1954

# O.H.V. 61 AND 74 V TYPE ENGINE BASE ASSEMBLY

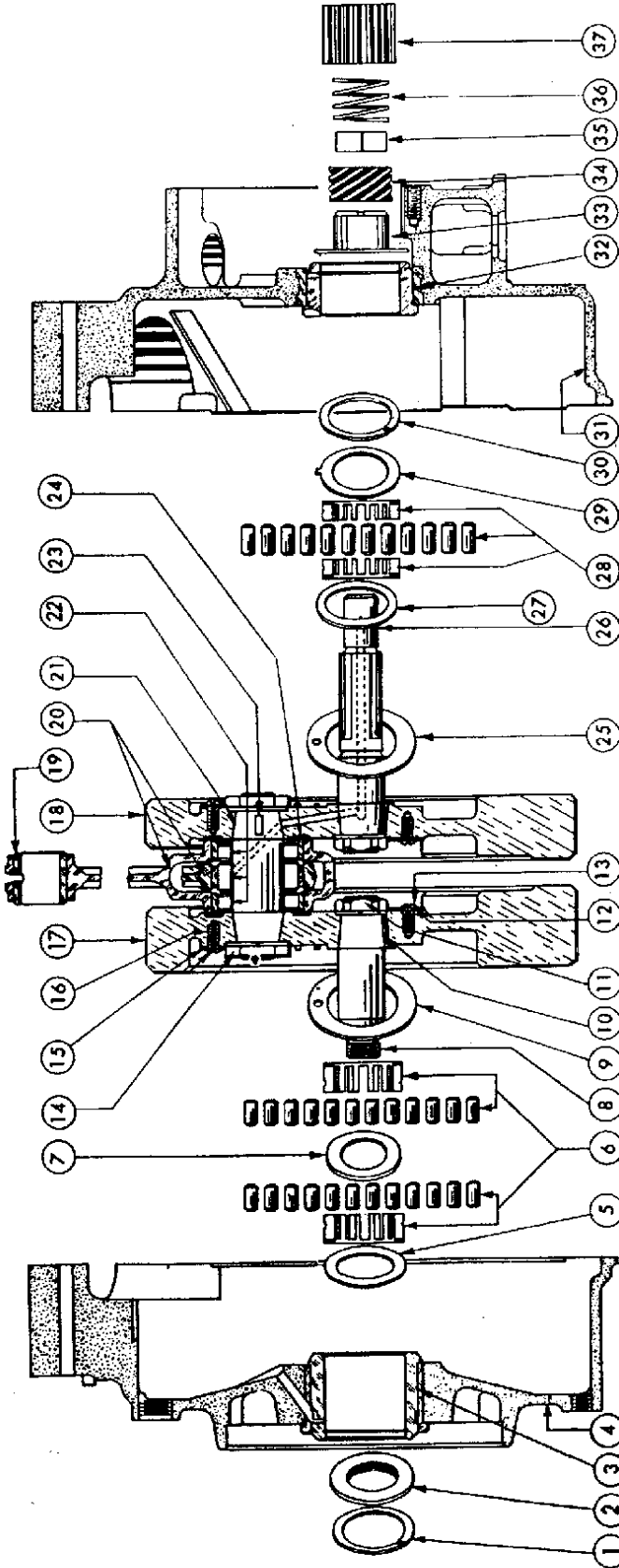

ITEM NUMBER	NUMBER USED	DESCRIPTION	ITEM NUMBER	NUMBER USED	DESCRIPTION
1	1	BEARING SPRING RING — (Same as item 30)	17	1	LEFT FLYWHEEL — When assembled, allow .012" to .014" end play in crankcase. Adjust and play with collars (Items 9 and 23).
2	2	OIL RETAINING BUSHING — (See item 3)	18	2	RIGHT FLYWHEEL
3	1	LEFT CRANK CASE ROLLER BEARING BUSHING — .0025" Press fit in case	19	1	PISTON PIN BUSHING — Bore or hone to fit piston pin .001" loose
4	1	SET OF CRANK CASES — NOTE: When only one-half case is damaged and needs to be replaced, return good half to the factory to be properly matched with the other half case. Left case is No. 406-40A and right case is No. 410-40A. 1941 and later 61 and 74 OHV, left case is No. 406-41 and right case is No. 410-41	20	1	SET OF CONNECTING RODS, with crank pin and roller bearing complete (Includes items 14, 21 and 22). Forked (rear) rod side play .006" to .010" between flywheel washers (item 24). Forked (rear) rod is No. 285-36 and single and (front) rod is No. 286-36
5	31	SPROCKET SHAFT BEARING WASHER	21	1	CRANK PIN
6	3	SPROCKET SHAFT ROLLER BEARING COMPLETE — Fit this bearing .0003" to .0012" loose. Bearing consists of 4 No. 301-40 retainers, 18 No. 304-40 long rollers and 36 No. 304-40 short rollers. (See FOOTNOTE NO. 1.)	22	1	CRANK PIN ROLLER BEARING COMPLETE — Fit this bearing .001" to .0012" loose. Bearing consists of 4 No. 301-40 retainers, 18 No. 304-40 long rollers and 36 No. 304-40 short rollers. (See FOOTNOTE NO. 1.)
7	1	SPROCKET SHAFT AND GEAR SHAFT NUT LOCK WASHER	23	2	CRANK PIN KEY
8	2	CRANK PIN AND SHAFT NUT LOCK WASHER	24	2	FLYWHEEL STEEL WASHER
9	4	LOCK WASHER SCREW — (Same as item 16)	25	1	GEAR SHAFT
10	2	CRANK PIN NUT	26	1	GEAR SHAFT ROLLER BEARING SPACER
11	2	CRANK PIN NUT LOCK WASHER — (See item 12)	27	1	GEAR SHAFT ROLLER BEARING COMPLETE — Fit this bearing .0008" to .0012" loose. Bearing consists of 2 No. 413-36 retainers and 12 No. 306-76 rollers. (See FOOTNOTE NO. 2.)
12	2	SPROCKET SHAFT COLLAR — .066" to .102" in steps of .004" — (Same as item 23)	28	1	GEAR SHAFT BEARING WASHER
13	2	SHAFT KEY	29	1	RIGHT CRANK CASE ROLLER BEARING BUSHING — .0025" Press fit in case
14	2	SPROCKET SHAFT AND GEAR SHAFT NUT	30	1	GEAR SHAFT BEARING OIL SEAL RING
15	3	CRANK PIN AND SHAFT NUT LOCK WASHER	31	1	OIL PUMP PINTON SHAFT GEAR (SPIRAL GEAR)
16	4	LOCK WASHER SCREW — (Same as item 16)	32	1	OIL PUMP GEAR AND PINTON GEAR SPACER
17	2	CRANK PIN NUT	33	1	BEARING OIL SEAL RING SPRING
18	2	CRANK PIN NUT LOCK WASHER — (See item 12)	34	1	PISTON
19	1	BEARING SPRING RING — (Same as item 30)	35	1	
20	1	OIL RETAINING BUSHING — (See item 3)	36	1	
21	1	LEFT CRANK CASE ROLLER BEARING BUSHING — .0025" Press fit in case	37	1	
22	1	SET OF CRANK CASES — NOTE: When only one-half case is damaged and needs to be replaced, return good half to the factory to be properly matched with the other half case. Left case is No. 406-40A and right case is No. 410-40A. 1941 and later 61 and 74 OHV, left case is No. 406-41 and right case is No. 410-41			
23	2	SPROCKET SHAFT COLLAR — .066" to .102" in steps of .004" — (Same as item 23)			
24	2	CRANK PIN AND SHAFT NUT LOCK WASHER			
25	1	GEAR SHAFT			
26	1	GEAR SHAFT ROLLER BEARING SPACER			
27	1	GEAR SHAFT ROLLER BEARING COMPLETE — Fit this bearing .0008" to .0012" loose. Bearing consists of 2 No. 413-36 retainers and 12 No. 306-76 rollers. (See FOOTNOTE NO. 2.)			
28	1	GEAR SHAFT BEARING WASHER			
29	1	RIGHT CRANK CASE ROLLER BEARING BUSHING — .0025" Press fit in case			
30	1	GEAR SHAFT BEARING OIL SEAL RING			
31	1	OIL PUMP PINTON SHAFT GEAR (SPIRAL GEAR)			
32	1	OIL PUMP GEAR AND PINTON GEAR SPACER			
33	1	BEARING OIL SEAL RING SPRING			
34	1	PISTON			
35	1				
36	1				
37	1				

FOOTNOTE NO. 1 — Referring to item 23: Diameter of standard rollers is .1875". Complete bearings are available with rollers from standard to .001" oversize in steps of .0002".

FOOTNOTE NO. 2 — Referring to items 6 and 28: Diameter of standard rollers is .250". Complete bearings are available with rollers from standard to .001" oversize in steps of .0002".

## DISASSEMBLING ENGINE FOR COMPLETE OVERHAUL

### Disassembling O.H.V. Engine

(After Removing From Chassis Completely Assembled)

1. Remove upper-end parts as outlined under "Disassembling Engine for Top Overhaul Only" (O.H.V. Engine)
2. Remove pistons. See "Piston and Pin."
3. Remove generator as outlined under "Removing Generator."
4. Remove circuit breaker assembly from crankcase: Free low tension wire from clip on crankcase—if wire is shielded, disconnect metallic shielding from crankcase stud. Remove relay and relay bracket. Remove two cap screws (9) and then circuit breaker completely assembled can be lifted off. Be careful not to damage base gasket if new one is not available.
5. Remove gear case cover: Remove gear case cover screws and cover is then free to be removed. Cover is located on dowel pins which fit rather snugly and it must be worked off these pins carefully to avoid damage to cover and joint faces. Do not pry off with screwdriver inserted between joint faces. Use a hammer and a block of wood and tap lightly at the ends where the cover projects beyond the gear case.  
Unless a new gasket is available, be very careful not to damage or break the old one as this gasket is special as concerns thickness and hole for oil passage. It should be replaced with a "factory-made" gasket.
6. Remove timing gears: After removing lock rings and collars from gear studs, gears, breather valve and pinion shaft fittings, except gear shaft bearing oil seal ring can be removed. Gear shaft bearing oil seal ring cannot be removed until after removal of oil pump drive gear.
7. Remove oil pump:  
remove in order named, the five nuts, one cap screw and washers that secure pump to crankcase, pump cover, governor rotor, cover plate and the countersunk flat head screw that secures pump to crankcase.

Remove lock ring, and drive shaft gear and key from inner end (inside gear case) of pump drive shaft, and then pump with shaft assembled can be removed from crankcase.

Unless new gaskets are available, be very careful not to damage or break the old ones. These are special gaskets as concerns both thickness and holes for oil passages. It is not advisable to attempt to replace them with "home-made" gaskets. Leaving out one hole or getting one in the wrong location is enough to put the entire oiling system out of commission. When new gaskets are needed, they should be replaced with "factory-made" gaskets.

8. Disassemble crankcases: Crankcases are held together with one cap screw, six studs with a nut on each end and one crankcase breather stud assembly. The cap screw enters through left case and threads into right case. Take out cap screw and remove nut from one end of each stud. Three of these studs, the one at top between cylinders and two at bottom are a tight fit and will have to be driven out with a drift of somewhat smaller diameter than studs. With all studs and screws removed, crankcases can be separated. If they don't come apart freely, tap at mounting lugs, using a block of wood and a hammer. Main bearing parts shown in Illus. 62 are now exposed.
9. Disassemble flywheels: Remove lock washer and nut from left end of crank pin. Tilt flywheel assembly on right flywheel and strike rim of left wheel with soft hammer about 90° away from pin. One or two sharp blows will usually loosen wheel. Do not strike wheel on its side, as doing so might either break flywheel or damage the tapered hole. With flywheels apart, connecting rods and roller bearing assembly can be removed from crank pin. Note that female (forked) rod is for the rear cylinder and male (single end) rod is for the front cylinder.

In connection with a complete overhaul, where all main bearings as well as connecting rod lower bearings are to be refitted, remove all shafts from flywheels. When crank pin is removed from right flywheel, it will be noted that this end of pin is a taper fit in flywheel, the same as the other end, but in addition is keyed. The purpose of this key is to locate the drilled oil passage in crank pin so that when wheels are assembled it will register exactly with drilled oil passage in right flywheel.

## Installing Timing Gears (O.H.V. Engine)

Before installing timing gears, install on pinion gear shaft in the following order: oil pump drive gear (34), spacing collar (35), spring (36) and pinion gear (37) as shown in Illus. 62.

Install the .050" thick steel thrust washer on inner end of cam gear shaft. Install timing gears (2) and (4) and breather valve (3) in gear case with marks in alignment, including the two marks on pinion gear, as shown in Illus. 64. Install spacer and split lock ring on circuit breaker drive gear stud. Install breather screen and screen separator in breather pocket in crankcase, with separator above as shown in Illus. 64, and scalloped edge of separator inward against crankcase.

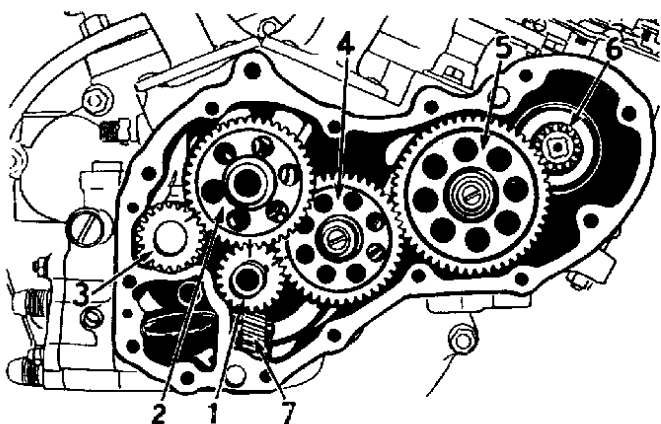

ILLUS. 64 1948 - 1954

TIMING GEARS WITH MARKS IN CORRECT ALIGNMENT  
(O.H.V. ENGINE)

1. Pinion gear. Gear and shaft are spline engaged and gear is a slip fit on shaft.
2. Cam gear. (Steel spacing washer behind this gear).
3. Breather gear.
4. Circuit breaker drive gear. (Spacing collar in front of this gear).
5. Intermediate gear (not marked). (Spacing collar in front of this gear).
6. Generator drive gear (not marked).
7. Oil pump drive gear (not marked); secured on end of pump drive shaft with key and spring ring.

## Installing Timing Gear Case Cover (O.H.V. Engine)

Before installing cover, lay engine on its side and pour about  $\frac{1}{4}$  pint of engine oil over timing gears.

Unless gear case cover gasket is in good condition, install a new "factory-made" gasket. Never use a "home-made" gasket as this gasket has holes especially located for oil passages and if a hole is left out or put in wrong place oiling system will not function normally. Install cover and all gear case cover screws. Tighten screws securely, and turn engine and note whether or not it turns freely. If new cam gear shaft bushings were installed and considerable drag is felt, it is very likely that the cam gear thrust washer may be too thick and must be ground thinner, to give cam gear from "free running" to

.005" endplay. Check endplay of cam gear with a thickness gauge, through tappet guide hole.

After correct endplay has been established, install tappets and tappet guides. See "Valve Tappets and Valve Tappet Guides."

## 1948-1954 Gear and Crankcase Data and Procedures

### Cam Gear Shaft and Pinion Gear Shaft Bushings (O.H.V. Engine)

Check cam gear shaft bushing in right side crankcase, and cam gear shaft bushing and pinion gear shaft bushing in gear case cover for extent of wear. These bushings normally do not require renewal until an engine has run extremely high mileage. However, if engine has been run under dusty conditions without an air cleaner, or without giving proper attention to air cleaner if engine is so equipped, and considerable road dust has been taken into engine through carburetor, abnormal wear may be found at any mileage.

Specified clearance for cam gear shaft in cover bushing and crankcase bushing is .001" to .0015", and for pinion gear shaft in cover bushing is .0005" to .001". When bushings are worn to the extent of increasing clearance to .0025" or more, they should be renewed, as the cam gear is likely to become noisy with excessive clearance in these bushings. Worn bushing in case can be pushed out with an arbor press, supporting case on a suitable collar or sleeve at flanged end of bushing. Bushings in cover, must be pulled with Harley-Davidson special puller, Part No. 11952-36

Before removing old bushings, note location of oil transfer hole in pinion gear shaft bushing in timing gear case cover. New bushing must be installed with oil transfer hole in same location (transfer hole to line up with drilled oil passage in cover) as normal function of oiling system depends upon correct location of this hole. The cam gear shaft bushing in crankcase must be installed with oil slot in flange end of bushing upward.

Before pressing in new bushings note location of original dowel pin holes in crankcase and/or gear case cover for reference when drilling new dowel pin holes. When drilling dowel pin holes in crankcase and/or gear case cover, be sure to locate holes  $\frac{1}{8}$ " or more from original dowel pin holes.

When pressing in bushings be sure bushing flanges are seated tight against crankcase and or gear case cover.

After new bushings have been pressed in they must be dowel pinned to prevent them from turning.

by drilling a hole with a number 31 drill, 9/32" deep, through bushing flange and into aluminum so when dowel pin (Part No. 661-31) is driven in and bottomed, its end will be slightly below face of bushing flange. Peen bushing around dowel pin hole to prevent pin from coming out.

Oil hole for lubrication of cam shaft bushing in cover, will have to be drilled, with a 5/32" drill, using oil hole already in bushing boss as a drill guide.

After bushings have been pressed in, dowel pinned and necessary oil hole drilled, they must be line reamed with Harley-Davidson special reamers, Part Nos. 12134-36 and 12132-36. Cover must be installed and secured by at least four screws when line reaming bushings.

**Line reaming pinion gear shaft bushing:** Insert steel pilot bushing into crankcase roller race—insert Harley-Davidson special reamer, Part No. 12132-36, through pilot bushing, into pinion gear shaft bushing, and turn reamer until it bottoms in gear case cover. See Illus. 46.

**Line reaming cam gear shaft bushings:** Insert Harley-Davidson special reamer, Part No. 12134-36, through crankcase bushing, into cover bushing, and turn reamer until it bottoms in gear case cover.

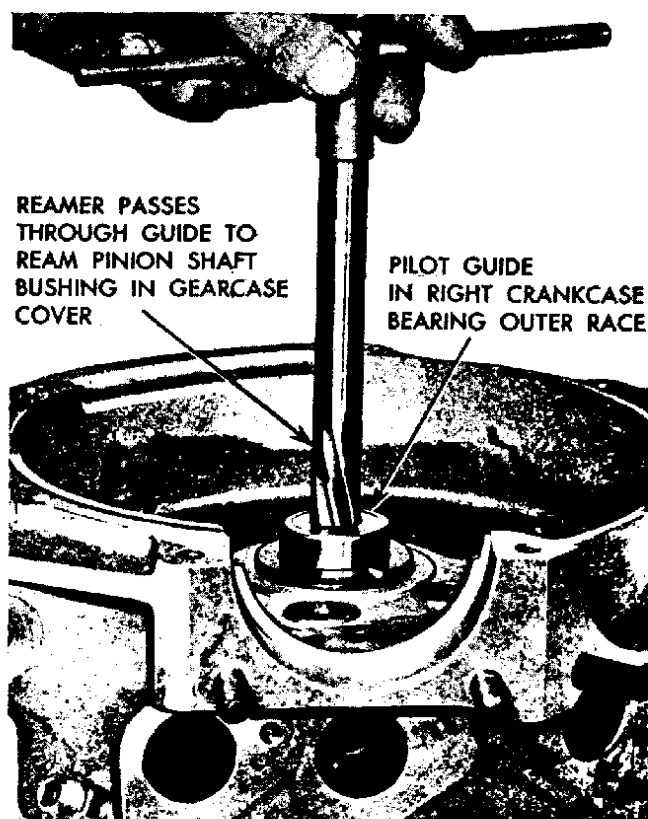

ILLUS. 46

LINE REAMING PINION GEAR SHAFT BUSHING

Pinion Shaft—Late style pinion shaft is .0015 oversize when new. Use std. pinion gear. Pinion gear marked "P" is .0015+. (Late shaft identified by screw in outer end.)

### Truing and Sizing Main Bearing Races

Before refitting worn main bearings, lap outer races to true them and remove any trace of wear shoulder at sides of roller paths using Harley-Davidson special lap, Part No. 11954-40 (see Illus. 48). Note: Before lap can be inserted in crankcase bushings, bearing washers, bearing spring rings and oil retaining bushing must be removed from the crankcase bushings. A race that is worn .0005" or more should be renewed.

When renewing main bearing races, heat cases (not over 300° F.) around races. Heating expands cases slightly and less force is required to press old races out and new races in. New races after installation, should also be lapped to smooth, true and align them, and to size them so that specified bearing clearance can be attained with roller sizes available.

When lapping main bearing races, right and left cases must be assembled and three or more studs

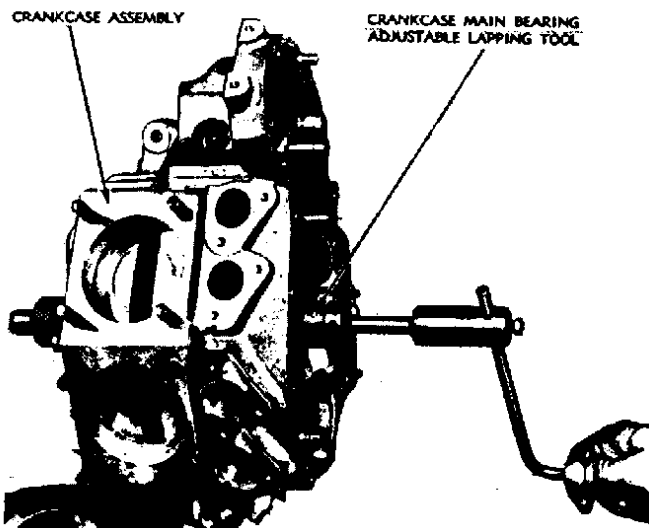

ILLUS. 48

TRUING AND SIZING MAIN BEARING RACES

securely tightened as in final assembly; this is to assure perfect alignment between left and right races in final assembly. Lap first one side and then the other, guiding lap by means of pilot bushing in opposite race. Adjust lap snugly in race and use only a light application of fine lapping compound. A loose lap and the use of excessive amount of compound results in tapered bearing surface.

### Fitting Main Bearings

When fitting main bearings, the shafts that are to be used when flywheels are reassembled can be used as gauges (see Illus. 49) with which to determine when bearings are fitted to correct clearance. Use the largest roller size that will allow shaft just noticeable shake in bearing. Bearing must not be fitted so tight that shaft has no shake at all. In making this check, all bearing parts must be perfectly clean and dry; oil in the bearing will take up some clearance and make bearing feel tighter than it is actually fitted. Sprocket shaft clearance in left main bearing should be .0005" to .001"; pinion gear shaft clearance in right main bearing should be .0008" to .0012".

After main bearing fitting is completed, crankcases with roller and retainer assembly can be set aside until flywheels are assembled.

Mainshafts can now be installed to their respective flywheels, sprocket shaft to left (heavier) flywheel, pinion gear shaft to right (lighter) flywheel. Wipe shaft tapers and flywheel tapers perfectly clean and free of oil. Be sure keys are in place. Tighten nuts very tight, using Harley-Davidson special wrench, Part No. 11933-X. Install lock washers. Lock washer can be installed either side up as it best matches lock screw hole. If necessary, tighten nut a trifle more to make lock screw holes match. Install lock screw and tighten securely.

After right side (pinion gear) shaft is installed check oil passage through shaft and side of flywheel with compressed air, to be sure passage is open.

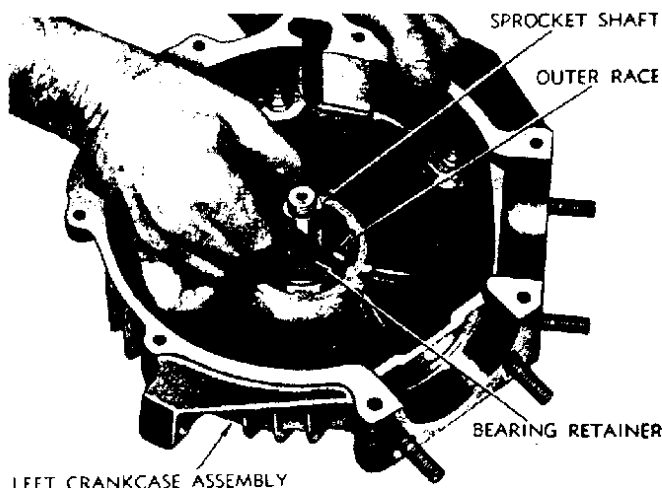

ILLUS. 49

USING SPROCKET SHAFT AS GAUGE TO DETERMINE BEARING FIT

### Servicing Flywheels and Installing Crank Pin

First give attention to flywheel washers (24), Illus. 62 or 63. If washer in either flywheel is worn and grooved to any extent, it should be renewed. This hardened steel washer fits into recess in flywheel face around crank pin hole and takes side thrust of connecting rod lower end and bearing. Washer is a close fit in recess and is secured by punching flywheel metal tight against it at several points around outer edge of washer.

To remove washer, it is ordinarily necessary to drill a small hole ( $\frac{1}{8}$ " or smaller) at the outer edge of washer to permit getting a pointed tool underneath and prying it out. This hole should be small and should be drilled only to slightly greater depth than thickness of washer. Drilling hole too large or too deep weakens flywheel and it may crack at that point. Before installing new washer, scrape outer edge of recess where metal was punched against old washer and thoroughly clean recess, as new washer must seat fully against recess bottom. If washer is carelessly installed and does not seat fully in recess, female (forked) rod is not likely to have required sideplay when flywheels are assembled.

Crank pin can now be installed in right flywheel. Wipe pin taper and flywheel taper perfectly clean and free of oil. Be sure key is in place. Tighten nut very tight, using Harley-Davidson special wrench, Part No. 11933-X. Install lock washer as it best matches lock screw hole—some washers can be installed either side up, others have two screw holes. If necessary, tighten nut a trifle more to make lock screw holes match. Install lock screw and tighten securely.

Check oil passage through pinion shaft, right flywheel and crank pin, with compressed air. Be sure this passage is open.

### Truing and Sizing Connecting Rod Lower Races

In lapping a set of worn rods (use Harley-Davidson special lap, Part No. 11944-36), lap until no trace of wear shoulder is left at sides of roller path; also lap both rods to fit same size rollers.

When rod lower races are damaged or worn beyond truing up and refitting with largest oversize rollers, rods must be replaced with new or returned to factory for refitting with new lower races. It is not practical for other than the factory to renew these races as they are distorted considerably when pressed into rods and the initial truing must be done with a grinder; lap is intended only for smoothing up and resizing races, worn or not exactly the right size.

Turn lap in lathe 150 to 200 R.P.M. (see Illus. 50). When means of turning lap are not at hand, hold in vise and turn rod. Adjust lap to snug fit in race before applying lapping compound; a loose lap will "bell mouth" bearing race. Apply light coat of fine lapping compound. To avoid grooving or tapering lap, work rod back and forth along its full length.

New rods ordered from the factory or used rods returned to the factory for rebushing are usually ordered fitted with crank pin and rollers. If not, they are likely to need lapping to fit available rollers with specified clearance.

After it has been determined that lower end races are in good enough condition to be lapped and re-fitted, upper end bushings should be inspected for need of attention. Check bushings for looseness in rods as well as pin clearance (see "Installing and Fitting Connecting Rod Upper Bushing.")

Rods that have been returned to the factory for new lower end races will also be fitted with new upper end bushings, reamed to correct clearance for standard pin. This, of course, also applies to new rods.

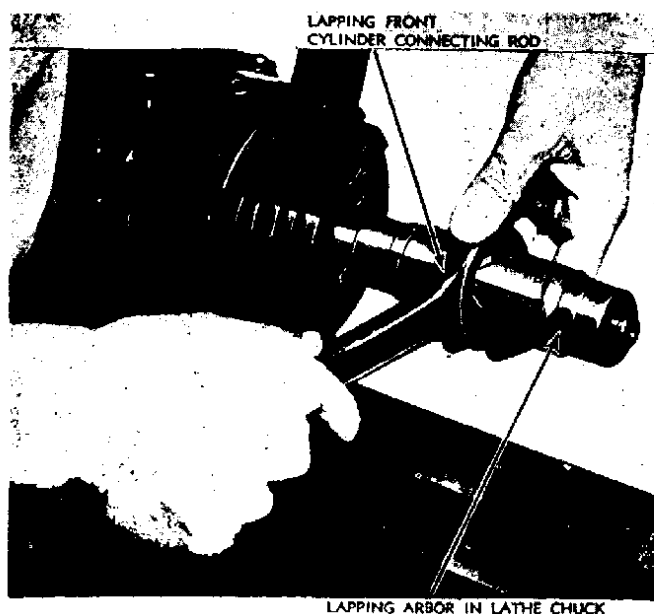

ILLUS. 50

TRUING AND SIZING CONNECTING ROD LOWER RACE

### Determining Correct Lower Bearing Fit

(See "Checking Connecting Rod Lower Bearing for Excessive Wear and Looseness," for information on checking lower bearing in connection with top overhaul and how much looseness may be allowed before bearing must be refitted.)

After lapping lower races of used rods as necessary, to smooth and true them, or replacing rods with a set with new lower races, install set of rollers and retainers on crank pin; rollers must always be new. Check fit of rods on bearing assembly. In making this check, flywheel pinion gear shaft must be gripped tightly between copper-faced vise jaws to hold flywheel firmly in a horizontal position. If neither rod will start over bearing, select a smaller set of rollers. If they go over easily and there is considerable shake at top end of rods, install a larger set of rollers. If lower end race of one rod is found to be slightly larger than the other, select rollers of a size that come closest to correctly fitting larger rod race and then lap rod with smaller race to bring it

up to same size, rather than fit with rollers of two sizes.

When rods are correctly fitted with required bearing clearance, extreme upper end of female (forked end) rod will have just noticeable side shake; extreme upper end of male (single end) rod will have .025" to 1/32" side shake. This check should be made with bearings clean and free of oil. Fitting tighter is likely to result in a seized and damaged bearing shortly after engine is put back in service.

Overall width of roller retainer assembly must be less than width of female rod end. Check to be sure of this.

### Assembling Connecting Rods and Flywheels

After correct connecting rod bearing fit has been attained, thoroughly clean all parts and lubricate with engine oil preparatory to assembling flywheels. Install connecting rods on crank pin bearing so female (forked end) rod will be to rear and male (single end) rod will be to front.

With right side flywheel and rod assembly held in vise copper jaws, wipe crank pin taper and left flywheel taper perfectly clean and free of oil, then install left flywheel and align as nearly as possible concentric with right wheel by means of a straight edge held against outer face of wheel rims, 90° from crank pin—see Illus. 51. Install nut on crank pin and tighten lightly. Check rim faces again with straight edge and, if tightening nut has shifted wheel, correct its position by striking rim of wheel with a lead or copper hammer. Do not use steel hammer. Turn nut tighter and repeat straight edge check. To prevent flywheel assembly from turning in vise while tightening nut, insert a rod approximately 1/2" diameter and at least 5" long through holes in flywheels and shift flywheels in vise jaws so that rod bears against some part of vise.

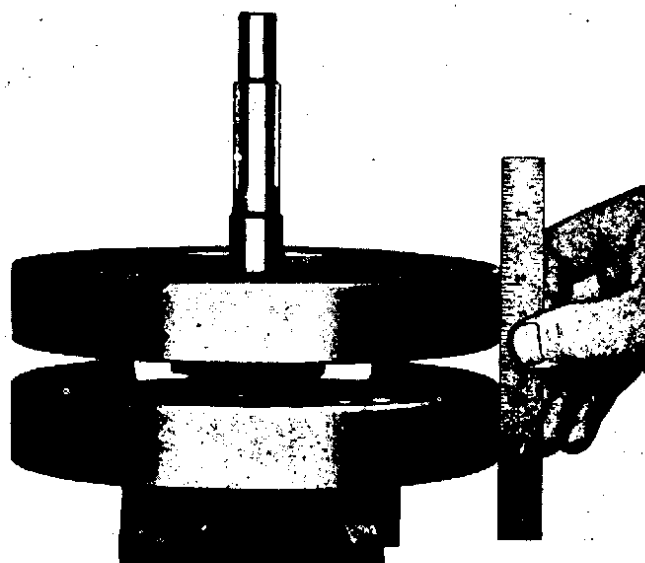

ILLUS. 51

CHECKING FLYWHEEL RIM FACES



After nut has been turned fairly tight, install flywheel assembly in truing device as shown in Illus. 53, and true according to indicators (see "Truing Flywheels)."

Remove wheels from truing device, again hold in vise as before and securely tighten crank pin nut. Pull this nut very tight. Now check the sideplay of female (forked) rod between flywheels (see Illus. 52). Sideplay should be .006" to .010". Check with thickness gauge. Push the rod end tight against one wheel and insert thickness gauge between rod and other flywheel. If it is found that there is too much sideplay, probably all or most of the excess play can be taken up by pulling crank pin nuts a little tighter. If there is not enough play, it is due to one of the following conditions: Flywheels and crank pin assembled with oil on tapers and nuts over-tightened (crank pin nuts must be pulled very tight but, of course, tightening can be overdone); new flywheel washers installed and not fully seated (see "Servicing Flywheels and Installing Crank Pin, tapered holes enlarged as a result of flywheels having been taken apart and reassembled several times in connection with previous overhauling; a flywheel cracked at tapered hole.

In a case like this, the first thing to do is recheck flywheel washers. If these washers are found fully seated and secured in flywheels, the next best thing to do is determine which flywheel seats farthest on crank pin taper, due to enlarged tapered hole or crack, and replace that wheel with a new one. Another thing that can be tried is exchanging crank pin for another new one. However, there is ordinarily very slight variation in length of crank pins. As a last resort, side faces of forked rod lower end can be ground off as necessary to gain required sideplay. If this is done, backs of retainers may also need to be ground off slightly as retainer assembly must, in every case, be narrower than female (forked) rod.

After rod sideplay has been checked and adjusted, crank pin nut pulled very tight and nut lock washer installed, again install wheel assembly in truing device and recheck for trueness.

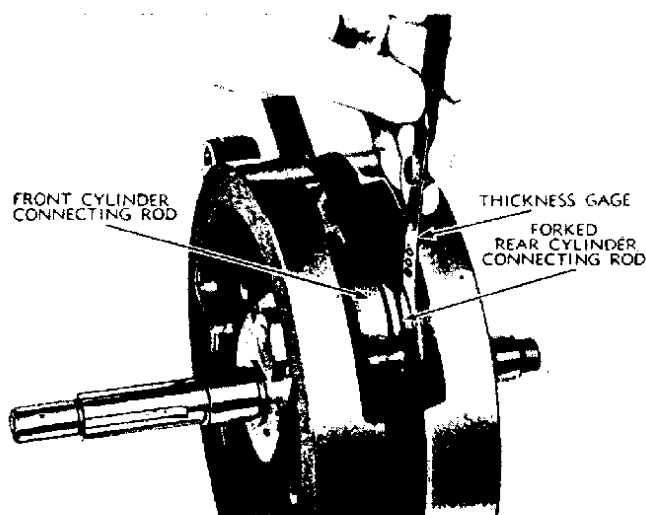

ILLUS. 52  
CHECKING CONNECTING ROD SIDE PLAY

**CAUTION:** After flywheels and rods are assembled, make final check to be sure oil passage is open to rod roller bearing. Apply compressed air to oil hole in side of pinion shaft, near its outer end, and observe that air escapes around connecting rod lower end. If this passage becomes blocked (closed off) in some manner and engine is assembled and put in service with it blocked, engine will get no lubrication, except in the timing gear case. This is not likely to be detected until serious damage has been done, as the oil circulation indicator in instrument panel will give no warning when the oiling system is blocked in this passage.

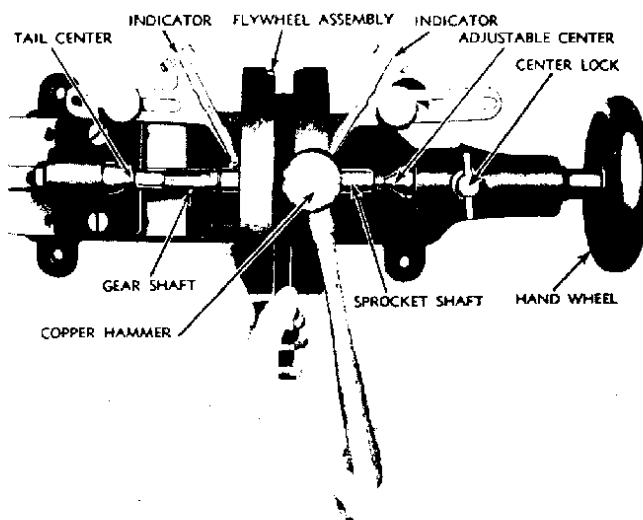

ILLUS. 53  
TRUING FLYWHEEL MAINSHAFTS

## Truing Flywheels

Bear in mind that, while a straight edge across rim faces is used when assembling flywheels to keep them as near as possible true with each other, final truing is a matter of truing sprocket shaft and pinion gear shaft to perfect alignment with each other, rather than truing flywheel rims. Install wheel assembly in truing device (Harley-Davidson truing device, Part No. 11962-X) and adjust so that centers are just snug (wheels must turn freely). If flywheel assembly is either loose between centers or is squeezed, indicators will not indicate accurately. Indicators should be adjusted as closely as possible to flywheels, and so that pointers rest about in the middle of graduated scales (see Illus. 53).

Turn flywheels and observe the movement of indicator pointers. Movement of pointers toward flywheels indicate high points of shafts. Find highest point of each shaft and chalk-mark flywheel rims at those points. Loosen centers slightly, just enough so it can be detected that flywheel assembly is a trifle loose. Turn high point of first one flywheel and then the other to the top and strike rim of wheel one or more sharp blows with a lead or copper hammer. The number of blows required and how hard they should be depends, of course, on how far shafts are out of true. Remember that centers

should be loosened slightly before striking flywheels. However, they should not be loosened to the extent of allowing flywheels considerable play between centers, as making them very loose is likely to result in broken or damaged centers.

After striking wheels with hammer as explained above, readjust centers to just snug and again turn wheels and check with indicators. Repeat the truing operation until indicators show within .001" of true. Each graduation on indicator scale is approximately .002"; therefore, when shafts are true within requirements, neither indicator will move more than about one-half graduation.

In the case of a flywheel assembly that is considerably out of true and which cannot be trued up by following the procedure described, it may be due to crack at one of the flywheel shaft holes or a damaged and enlarged tapered hole. If used sprocket and pinion shafts are assembled in flywheels, it may be due to one of these shafts being worn considerably out of round at the point where indicator takes bearing against it.

### Assembling Crankcases

Flywheels are now ready to be assembled into crankcases which have already been given due attention as concerns main bearing fitting (see "Fitting Main Bearings.") A strong rack or box with an opening about 8" x 8" and at least 4" deep should be available, on which to place right crankcase on its side. O.H.V. Engine: With pinion gear shaft bearing spring ring engaged in groove in roller race, install bearing washer, bearing assembly and bearing spacer

*All Models:* Select two flywheel thrust collars and install one on each flywheel hub. Be sure they register on dowel pins and seat fully against wheel faces. These collars come in various thicknesses (.066" to .102" in steps of .004") to permit adjusting flywheel endplay between crankcases. The only way to determine exactly what collar thickness is required is to try one set and then another until the correct endplay is attained. The average thickness of collars used in new engine assembly is about .086". Both collars should be approximately the same thickness in order to keep flywheels centered in crankcases and connecting rod upper ends centered between piston pin bosses.

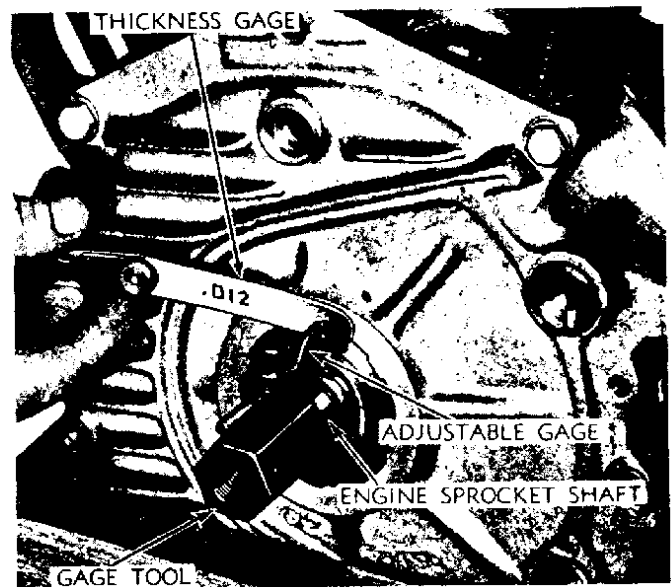

ILLUS. 55

CHECKING ENDPLAY OF FLYWHEEL ASSEMBLY IN CRANKCASE

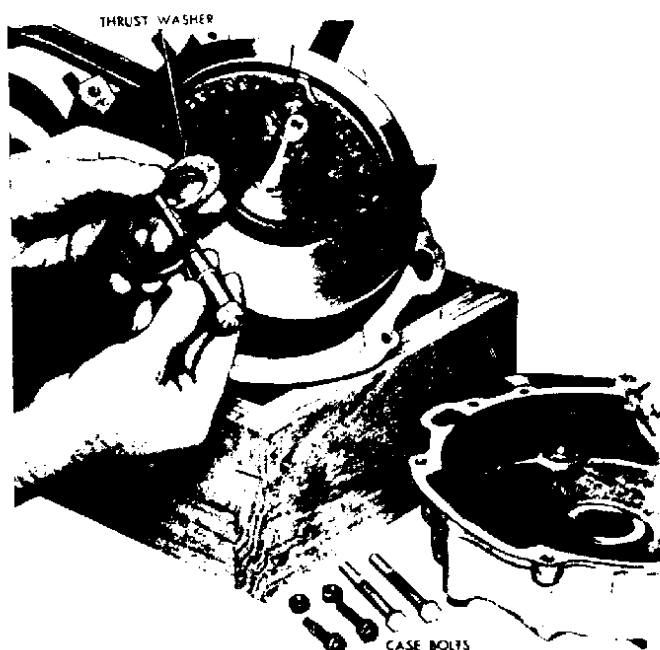

ILLUS. 54

MEASURING THICKNESS OF FLYWHEEL THRUST WASHER

When a set of collars has been selected and installed on flywheels, install flywheel assembly into right crankcase. Install sprocket shaft roller bearing assembly and bearing washer on sprocket shaft in the order shown in Illus. 62 or 63, and install left crankcase. No gasket is used on crankcase center joint, and joint should not as yet be coated with gasket cement or sealer. Insert stud at top center of cases and two studs at bottom of cases. Install and tighten nuts, to clamp cases securely together.

Now, by pushing back and forth on ends of sprocket and pinion shafts, check flywheel endplay. If no endplay is found, cases will have to be taken apart and thinner thrust collars installed. Reassemble and again check endplay. If it is found that flywheels now have endplay continue check with Harley-Davidson endplay gauge, Part No. 11967-38, as follows: Install endplay gauge on sprocket shaft, and adjust gauge pin to just touch crankcase when flywheel is pressed toward gear case side. Now push flywheel toward left side case and use a thickness gauge to determine amount of flywheel endplay (see Illus. 55). When this has been accurately determined, it is then a simple matter to calculate how much thinner or how much thicker thrust collars

must be installed to attain correct endplay (.012" to .014").

After selecting and installing thrust collars of correct thickness, oil main bearings and proceed with final assembly.

Give both faces of crankcase center joint a moderate application of gasket cement or sealer.

After allowing cement or sealer to air-dry a few minutes, assemble crankcases, install all studs, nuts and cap screws and tighten securely. Remember, three of the crankcase studs, the one at top center and the two bottom studs, are drive fit studs that locate crankcases in exact relation to each other. These studs must not be replaced with loose-fit studs. After crankcase assembly is completed, recheck to be sure flywheels have at least the specified minimum endplay.

### Installing Generator

Install generator idler gear:

*O.H.V. Engine*—install idler gear (5), Illus. 64, spacer and lock ring on stud.

The metal shim (.014" thick), used with standard generator fitted with larger diameter drive gear (later O.H.V. Models only), is to be placed directly on cradle with paper shims above. See "Removing Generator,"

*All Models:* Inspect generator drive end gasket and if damaged replace with a new one. Secure gasket to generator end with gasket cement or sealer.

If the original number of paper shims are at hand, use them when installing generator. If original paper shims are not available, then start out with three new shims (shim is approximately .004" thick) placed between generator frame and its cradle.

If generator frame has a small oil drain hole near the drive end, be sure holes in shims line up with hole in generator frame and hole in cradle, so drainage will not be blocked. However, some generators may not have a drain hole in frame and in that case disregard holes in shims. Just a small amount of grease applied to shims and cradle will hold shims in place while installing generator.

With shims in place on cradle, install generator and assemble convex washer, lock washer and nut on strap end, but do not tighten nut as yet.

Insert, temporarily, the two long screws that secure generator to timing gear case. Inasmuch as gear case cover is not yet installed, its thickness will have to be taken up by suitable spacers (nuts or collars) under screw heads to permit screws to be tightened. Tighten mounting screws snugly (not tight); then tighten generator mounting strap nut. Now loosen mounting screws to allow generator to adjust itself, and then tighten these screws securely.

Check lash between generator drive gear and idler gear. Try this at several points around gears.

If it is found that gears have considerable lash, remove one or more paper shims from underneath generator. Gears must not, however, be meshed so deeply that no noticeable lash can be felt between all teeth as gears are turned.

### OHV GENERATOR GEARS

Later gears to 1957 O.D.-1.022

Use steel shim.

First OHV, WL and UL O.D.-1.000

No steel shim.

### END PLAY

Generator drive gear—Free to .003 lash

Idler gear—.005 to .007 end play

Dist. gear—.005 to .007 end play

Breather gear—.003 to .005 end play

OHV idler gear spacing collars not listed in parts book.

.530-# XA 674

.535-# XA 674A

.540-# XA 674B

Gear cover gaskets compress .010 to .012. Started shimming engines 50 FL 5840 for quite running.

To check end play deduct size of gasket to compressed size after measuring gears with new gasket in place. Use a straight edge.

### CAM & TIMING GEARS

All cam gear pitch diameter is .105".

B.T. cam gear std size measurement = 2.764.

Pinion gear std size measurement = 1.446.

Together they equal 4.210. The best combination without whine is 4.216.

# SHOP DATA:

## REMOVING AND REPLACING PINION SHAFT GEAR IN LATER O.H.V. ENGINES

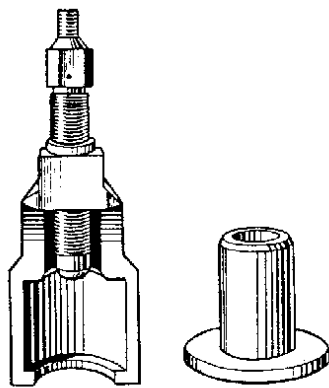

ILLUS. 1  
Pinion Gear Removing  
And Installing Tool Cata-  
log No. 96830-51.

1951 O.H.V. motorcycles with engine numbers above 51FL6137 and 51EL6976 are fitted with the new style pinion shaft. This new shaft is slightly larger than earlier shafts to assure a permanent tight fit in the pinion gear. It is enough larger so that pinion gear is definitely a press fit (up to .002" press) and the special tool illustrated and described is a definite requirement with which to properly install pinion gear on shaft, or remove gear. Do not attempt to drive pinion gear on this shaft as the driving force required is very likely to also drive flywheel assembly out of alignment. New shaft can be readily identified by the screw in its end, which plugs the threaded hole (5/16 x 24 left thread), provided for attachment of special tool when used in installing gear. Screw must also be out when pulling gear so that roller tip of puller screw seats in shaft center.

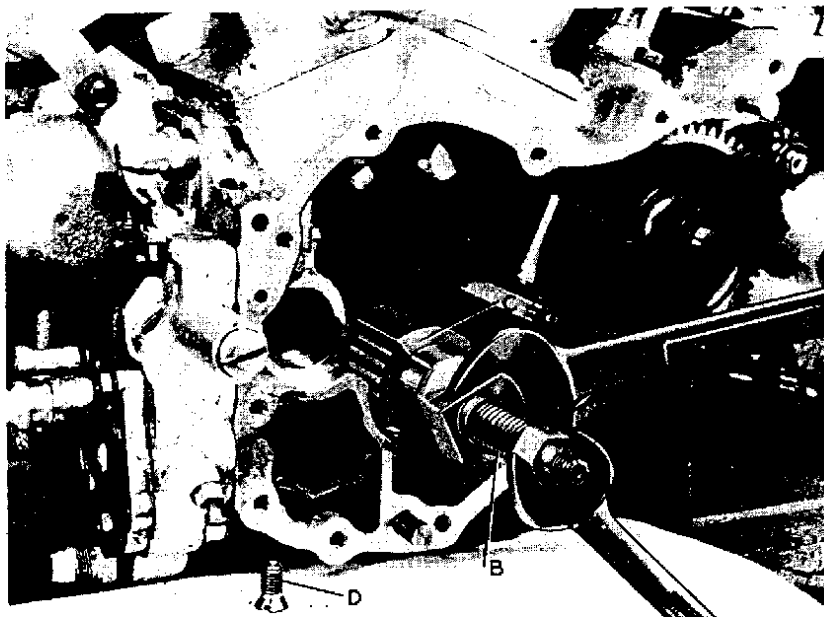

When necessary to remove gear, first remove screw (D) from end of shaft; then install tool and remove gear as shown in Illus. (2). The screw thread of tool should be kept well lubricated.

ILLUS. 2  
B. Tool Screw  
C. Tool Body  
D. Pinion Shaft Screw Plug

To install gear, turn tool screw (B) into end of pinion shaft and tighten securely. Position gear, locating collar (A), and body (C) as shown in Illus. (3). Turn tool body to press gear into position until locating collar firmly contacts joint face of crankcase. This will properly position gear with flywheel assembly shifted to the right to the extent of its side play in crankcase. Then when flywheel assembly shifts to its running position, pinion gear will have some clearance from bronze bushing in gear case cover.

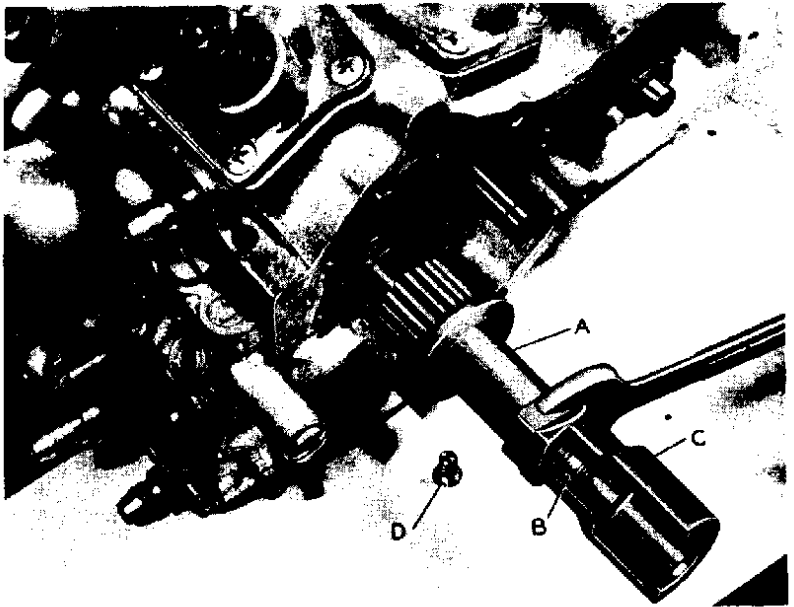

ILLUS. 3  
 A. Locating Collar  
 B. Tool Screw  
 C. Tool Body  
 D. Pinion Shaft Screw Plug

After gear has been installed, replace screw and carefully stake edge of screw head into one slot in end of shaft. If screw is not in place, oil pressure will be lost.

The screw in the end of the pinion shaft must, of course, be out when there is occasion to true flywheel assembly on truing device, catalog No. 11962-X. Before installing assembly between truing device centers, examine center in end of pinion shaft for burrs raised by screw head staking. Burrs found must be removed, otherwise flywheel assembly cannot be accurately trued.

Only the new shaft with screw is now furnished on parts orders under catalog old No. 356-39 (catalog new No. 24007-39.)

It is suggested that you place your order for this tool at once as engines with press fit pinion shafts have been going out for some time and there may be occasion any day to render some service requiring the removal and reinstallation of pinion gear.

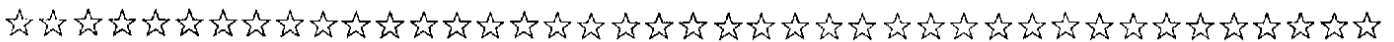

**Notes**

## Crankcase Drilling Jig Procedure

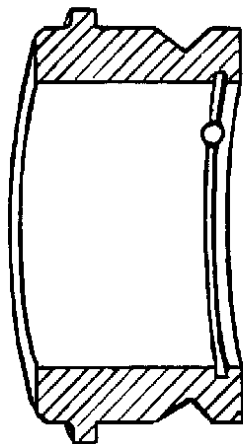

ILLUS. 2.

Beginning with engine No. 54FLE2077, right crankcase bushing, part No. 24599-40, is locked in the case with two screws. This is to prevent the possibility of the bushing working out of its bore a sufficient distance to take up flywheel end play, and to prevent bushing from turning in case.

The right crankcase bushing now supplied on parts order for OHV models from 1940 through 1954 has two notches in its outside diameter which provide seats for lock screws. See ILLUS. 2. This applies to both standard and oversize bushings listed in parts catalog.

When overhauling OHV engines from 1940 and up to engine No. 54FLE2077, it is highly desirable to install a new notched bushing in right case and lock it. This is especially true of a bushing that may have bearing surfaces damaged as the result of gear shaft bearing surface breakdown. Where this has occurred, small particles of metal from gear shaft have most likely damaged the bearing surface of bushing, even though damage may not be apparent to the eye.

After installing and locking new bushing, refit bearing with roller bearing assembly 29650-54. This bearing is described under FIG. 3 of Shop Dope No. 348. This bearing has greater bearing area than earlier bearings used. Beginning with engine No. 54FL5010, this bearing was used in production for the remainder of the 1954 season.

**INSTRUCTIONS FOR USING DRILL JIG:** ILLUS. 1 shows component parts of the drill jig laid out in the order of assembly. Items 1, 2, 3, 4 and 5 go to make up the part of the drill jig used in the flywheel side of the right crankcase. (Item 6) is the part of the drill jig used in the cam case side of the right crankcase.

First remove the right crankcase bushing.

Items 1, 4 and 5, in ILLUS. 1, are shown correctly assembled in ILLUS. 3, for installation in the flywheel side of right crankcase. Keeping this assembly intact, insert the ends of locating pin (Item 1, - ILLUS. 1) and pilot (Item 5, ILLUS. 1) simultaneously; the end of the locating pin into the cam shaft bushing and the end of pilot into the right crankcase bushing bore. This will bring the drill plate (Item 4, ILLUS. 1) flat against the flywheel side of crankcase. Install the plain steel washer (Item 3, ILLUS. 1) on cap screw (Item 2, ILLUS. 1), and insert cap screw through the center of drill plate and pilot. This will bring the steel washer flat against the drill plate. From the cam case side start the clamping bar (Item 6, ILLUS. 1), with flat side facing out, on the end of cap screw. Keep clamping bar in a vertical position and pull cap screw down tight. ILLUS. 4 and 5 shows drill jig correctly installed.



ILLUS. 3

**TO DRILL AND TAP THE CRANKCASE FOR LOCK SCREWS:** Lay crankcase on bench with cam case side down. Use an electric hand drill with 6" long, No. 16 drill. Drill through the right crankcase into bore, using the two drill pilot holes provided in drill plate (Item 4, ILLUS. 1). This procedure is shown in ILLUS. 5.

Remove drill jig from crankcase. From the flywheel side, tap the two holes using a No. 12 - 24 thread tap. When tapping these holes, extreme care must be

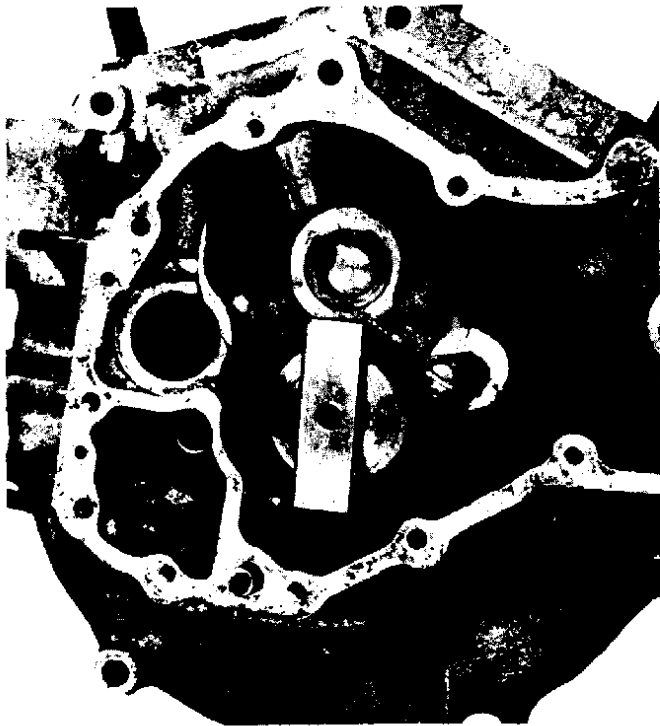

ILLUS. 4

taken in order to prevent tap breakage. Since the tap must go through both aluminum and steel, one of the best lubricants to use is a mixture of kerosene and lard oil. Work the tap clockwise and counterclockwise in order to keep the tap and hole free of shavings. Remove all burrs from tapped holes in crankcase bore. Install a crankcase bushing with notches provided for lock screws. The bushing must be installed in the crankcase with the oil groove in the inner face of bushing upward, and in line with the vertical center line of crankcase. This will align the two notches in the bushing with the lock screw holes.

Install the two lock screws and bottom them tight against the bushing. Use a suitable punch to upset threads at one point at end of screws to prevent them from loosening and working out.

The Part No. of the lock screw is 24608-54.



ILLUS. 5

**NOTE:** The right crankcase bushing should fit into its bore from .002" to .003" tight at normal room temperature. In other words, from .002" to .003" press fit.

When removing or installing a bushing it is recommended that crankcase be heated. This is especially desirable when installing a bushing in order to avoid the possibility of misalignment when starting the bushing into its bore.

If it is found that a standard size bushing has loosened to size to size fit in bore, fit a .002" oversize bushing. If it is found that a bushing has loosened and turned in bore, and as a result has increased the diameter of bore, fit a .005" oversize bushing, if from .002" to .003" press fit can be obtained. If the bore is worn to the point where a .005" oversize bushing cannot be used, send the crankcase to the factory to be rebored for a 1/32" oversize bushing.

# SHOP DATA:

(1951 and later)

## O.H.V. CONNECTING ROD BEARING RETAINERS AND BEARING ROLLERS

1951 O.H.V. models have different lower connecting rod bearing rollers and retainers than those used in earlier O.H.V. models. Retainer wall is thicker on closed end of retainer. This change was made to gain greater rigidity. Since the wall is thicker and the overall width of the retainer remains the same, the bearing rollers for 1951 must be shorter.

Only the 1951 retainer-roller assembly is now furnished under part number 309-40. The complete new assembly can be used in all Big Twins from 1940 to date.

To distinguish 1940 to 1950 individual rollers and retainers from later individual rollers and retainers refer to information below.

### 1940 TO 1950 BEARING ROLLERS

Short roller	Part Number 304-40	.344" long
Long roller	Part Number 305-40	.694" long

### 1951 BEARING ROLLERS

Short roller	Part Number 9101	.329" long
Long roller	Part Number 9171	.662" long

### THICKNESS-OF WALL (CLOSED END) OF RETAINERS, SEE SKETCH

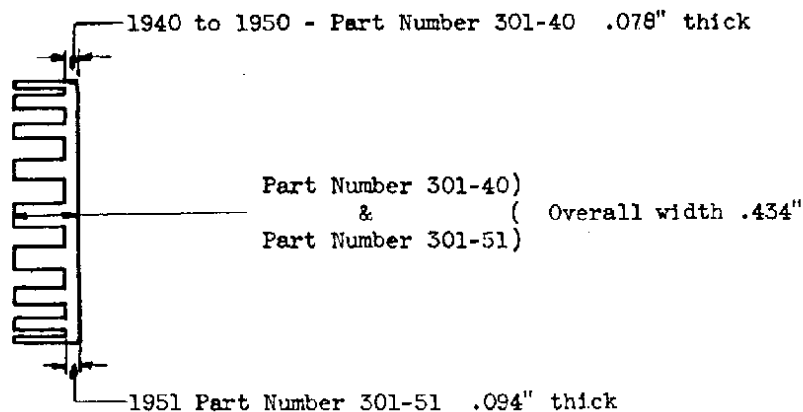

The shorter 1951 bearing rollers should not be used with 1940 to 1950 retainer part number 301-40. The longer 1940 to 1950 bearing rollers must not be used with the new 1951 retainer part number 301-51, as such a bearing assembly would lock tight when flywheels are assembled. This would result in quick failure.



# SHOP DATA:

1948 to 1952 -- 61 CU. IN. AND 1948 to 1954 -- 74 CU. IN. O. H. V.

## ENGINE FITTING SPECIFICATIONS

PISTON CLEARANCE-- New piston fitted in cylinder, .001" to .002" clearance.  
Piston shapes to cylinder and acquires more clearance after short time in service.

Measure piston at bottom of skirt, front to rear.

Measure cylinder about 1/2" from top of bore, front to rear.

PISTON PIN IN PISTON -- Light hand press fit.

PISTON PIN IN UPPER END OF CONNECTING ROD -- .0008" to .0012" loose.

PISTON RING GAP AND GROOVE CLEARANCE -- With rings inserted 1/2" to 3/4" from top of cylinder- Solid Type Rings .010" to .020" gap- U-Flex Oil Control Ring 11/32" overlap. Rings should be .004" loose in ring grooves of piston. U-Flex oil control ring used as standard equipment in 1953 and 1954 - 74 OHV models.  
LOWER CONNECTING ROD BEARING -- .001" to .0015" loose.

CONNECTING RODS -- .006" to .010" end play between flywheels -- roller and retainer assembly should be narrower, but not more than .010" narrower than forked rod.

SPROCKET SHAFT -- .0005" to .001" loose in roller bearing.

PINION GEAR SHAFT -- .0008" to .0012" loose in roller bearing -- .0005" to .0012" loose in cover bushing. Oil slot in cover bushing is centered with drilled feed oil passage in cover.

FLYWHEEL ASSEMBLY -- .010" to .014" end play in crankcase.

CAM GEAR -- .001" to .0015" loose in crankcase and cover bushings -- .001" to .005" end play.

INTERMEDIATE GEARS -- .001" to .0015" loose on studs -- .003" to .007" end play.

TAPPET GUIDES -- .0005" to .001" press fit in crankcase.

VALVE TAPPETS -- .001" to .002" loose in tappet guides.

ROCKER ARM FIT IN BEARINGS -- .001" to .002" loose -- .004" to .012" end play.

OIL PUMP DRIVE SHAFT -- .0008" to .0012" loose in crankcase bushing.

CRANKCASE BREATHER -- .001" to .005" end play -- timed with front cylinder -- opens 1/8" before top center to 1/8" after top center, and closes 13/16" to 1 5/16" after bottom center.

## SERVICING THE 1954 AND EARLIER OHV MODEL ENGINE PINION SHAFT BEARING

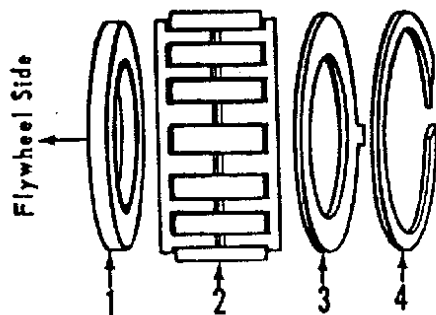

FIGURE 1

- 1 - 24695-40 Bearing Spacer (.122" thick)
- 2 - 24650-36 Bearing Complete - Consists of
  - (12) 9261 Bearing Roller ( $\frac{1}{4}$ " x .600")
  - ( 2) 24646-36 Bearing Retainer
  - (Overall Width .370")
- 3 - 24690-40 Bearing Washer
- 4 - 24702-40 Spring Ring

### FURTHER INFORMATION ON PINION SHAFT BEARINGS - READ CAREFULLY

Figure 1 on page 1 shows roller bearing and adjacent parts in correct order of assembly, as used in all OHV model engines from 1940 to late 1953. The bearing complete (2) part number 24650-36 is shown as it is being supplied on parts order.

NOTE: This bearing with adjacent parts shown (less spacer 24695-40) was used in earlier than 1940 OHV engines, and was also used in 74 and 80 cu. in. Side-Valve engines from 1937 through 1948. It is still the correct bearing to use in servicing engines referred to in this "Note".

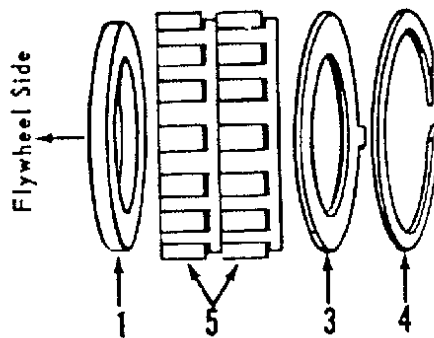

FIGURE 2

- 1 - 24695-40 Bearing Spacer (.122" thick)
- 5 - 24650-36 Bearing Complete - Consists of
  - (24) 9301 Bearing Roller ( $\frac{1}{4}$ " x .270")
  - ( 2) 24646-36 Bearing Retainer
  - (Overall Width .370")
- 3 - 24690-40 Bearing Washer
- 4 - 24702-40 Spring Ring

Figure 2 on page 1 shows roller bearing and adjacent parts in correct order of assembly as used in late 1953 and early 1954 OHV model engines.

NOTE: This bearing, carrying the same part number (24650-36) as bearing shown in Fig. 1, was used for only a short period of time and was then discontinued and replaced with bearing shown in Fig. 3. Bearing shown in Fig. 1 is now furnished on parts order calling for part number 24650-36.

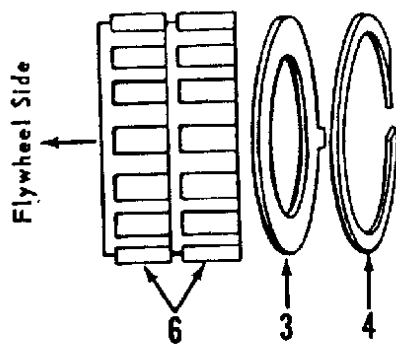

FIGURE 3

- 6 - 24650-54 Bearing Complete - Consists of
  - (24) 9321 Roller Bearing ( $\frac{1}{4}$ " x .360")
  - ( 2) 24646-54 Bearing Retainer
  - (Overall Width .434")
- 3 - 24690-40 Bearing Washer
- 4 - 24702-40 Spring Ring

NOTE: Spacer 24695-40 shown in Figs. 1 and 2 cannot be used with this bearing.

Figure 3 on page 1 shows roller bearing and adjacent parts in correct order of assembly as used in 1954 OHV model engines from engine number 54FL 5010 to the season's end. This bearing (24650-54) will not fit 74 and 80 cu. in. Side-Valve models or OHV models earlier than 1940.

NOTE: The 1955 OHV engine pinion shaft bearing was changed to gain greater bearing area.

**RECOMMENDATION** - Use only the bearing shown in Fig. 3 for all servicing of OHV engines from 1940 to and including 1954, as it has greater bearing area than earlier bearings used.

**PINION SHAFTS AND FITTINGS IN CORRECT ORDER OF ASSEMBLY**

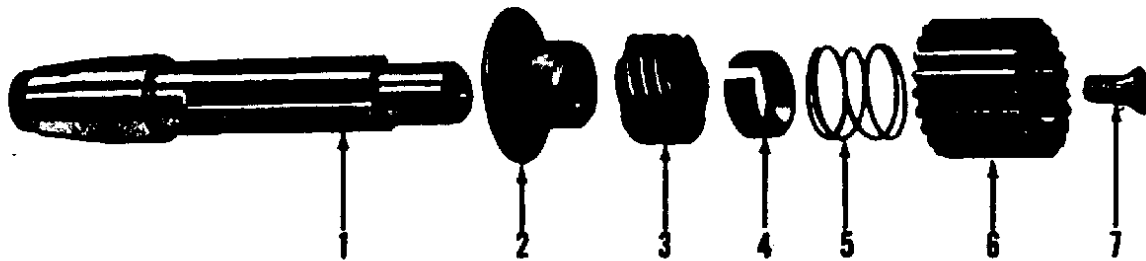

FIGURE 4

**PINION SHAFT AND FITTINGS USED IN 1940 TO AND INCLUDING 1953 OHV ENGINES**

- 1 - 24007-39 Gear Shaft
- 2 - 24697-40 Gear Shaft Bearing Seal Ring
- 3 - 26349-39 Oil Pump Drive Gear
- 4 - 24703-40 Gear Spacer
- 5 - 24699-37 Spacing Spring
- 6 - 24010-39 Pinion Gear
- 7 - 24020-51 Gear Shaft Plug (left thread)

NOTE: In original factory engine assembly, shaft with screw thread in end for pinion gear puller and installer tool, part number 96830-51 was used only since 1951; however, shafts under part number 24007-39, with or without threaded end and screw plug (7) are interchangeable. Only the shaft with the screw plug is furnished on parts order.

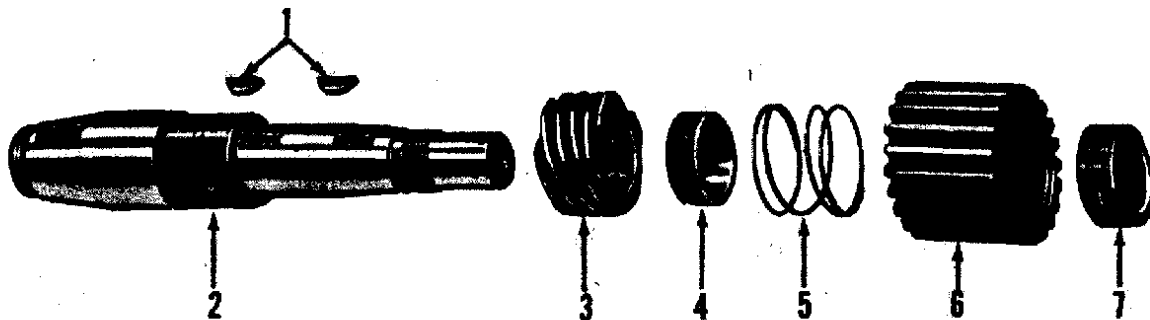

FIGURE 5

**PINION SHAFT AND FITTINGS USED IN 1954 OHV ENGINES**

- 1 - 23985-54 Gear Shaft Gear Keys
- 2 - 24006-54A Gear Shaft
- 3 - 26349-54 Oil Pump Drive Gear
- 4 - 24703-54 Gear Spacer
- 5 - 24699-37 Spacing Spring
- 6 - 24010-54 Pinion Gear
- 7 - 24023-54 Gear Shaft Nut (left thread)

NOTE: 1954 shaft and fittings cannot be installed in 1953 and earlier OHV engine, unless 1954 timing gear case cover is also installed (bearing end of shaft is smaller diameter).

## 1955-1957 GEARCASE

### OIL PUMP

#### GENERAL

The oil feed pump and scavenger (oil return) pump are gear type pumps housed in one pump body and located on rear of gearcase on right side of motor-cycle. The feed pump incorporates an automatic by-pass valve that reroutes surplus oil (above the amount needed to lubricate the engine) directly to the gearcase. This valve is preset and non-adjustable.

Under normal operating conditions, the pump is a comparatively trouble free unit. The most common trouble with pump operation is the introduction into the pump of a metal or hard carbon chip. If either

gets between the gear teeth, it is possible to shear a key, fracture a gear or break off a gear tooth.

If oil fails to return to the tank, check the scavenger pump gear drive shaft key. When the engine receives no lubrication (oil remains in tank), the drive shaft key on the feed pump drive gear may be sheared. Both of these conditions could be caused by shearing of the oil pump drive gear key. In cold weather slush ice formed from moisture condensation in oil may block oil passages and cause any of above troubles.

#### DISASSEMBLING OIL PUMP (Fig. 3D-1)

The oil pump may be removed from the motorcycle as a unit only if the engine is removed from the

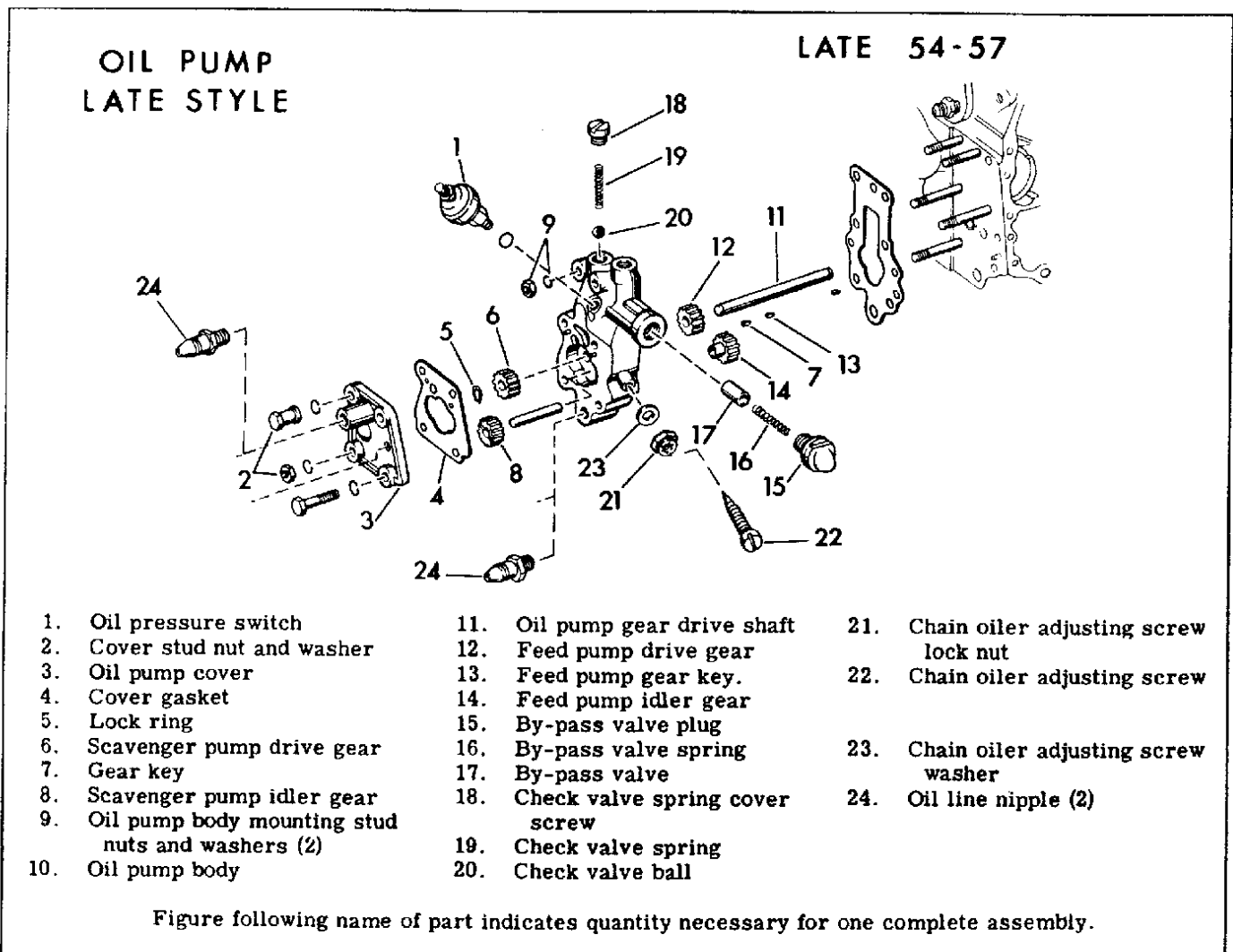

Figure 3D-1. Oil Pump - Exploded View

chassis. The oil pump may be disassembled, piece-by-piece without removing gearcase cover, with engine in chassis as follows:

Disconnect oil lines and oil pressure switch (1) from pump. See Fig. 3D-1A. Remove four nuts and washers (2) from gearcase studs, that hold oil pump cover in place. Remove oil pump cover (3) and gasket (4). Remove lock ring (5), scavenger pump drive gear (6), gear key (7) and scavenger pump idler gear (8). Remove two oil pump body mounting stud nuts (9) and slip pump body (10) off studs and gear drive shaft (11). Remove oil feed pump drive gear (12), key (13) and idler gear (14).

Turn relief valve plug (15) out of pump body and remove relief valve spring (16) and valve (17). Remove check valve spring cover screw (18), valve spring (19) and ball (20).

loosen chain oiler adjusting screw lock nut (21) and turn in adjusting screw (22). Count the turns necessary to bottom screw then remove. Bottom and turn out same number of turns when assembling.

To remove oil pump unit from gearcase with engine removed from chassis, remove gearcase cover screws, cover and gasket. Turn pinion gear nut off pinion shaft using the special tool, Gear Shaft Nut Socket Wrench, Part No. 94555-55 (left hand thread). Pull pinion gear using Pinion Gear Puller and Installer, Part No. 96830-51, remove key, spring, spacing collar and oil pump pinion shaft gear. Pry spring ring off pump drive gear shaft and remove drive gear and key. Remove six pump body nuts (2

and 9) and slip pump with drive shaft (11) out of gearcase. Pump is then disassembled as above.

#### CLEANING AND INSPECTION

Thoroughly clean all parts in cleaning solvent and blow pump body passages clear with compressed air. Inspect valves and valve seats for pitting and wear. Replace pump having worn or damaged valve seat. Inspect keys and keyways. Inspect scavenger and feed pump gear teeth for gouging or cracking caused by foreign materials going through pump. Pump shafts and bushing normally last lifetime of engine.

#### ASSEMBLING OIL PUMP

Oil pump is assembled in reverse order of disassembly. Note that scavenger pump gears are thicker than the feed pump gears. Also notice that feed pump gear key is smaller than scavenger gear key. Oil pump gaskets should always be replaced. Wet new gasket with water before assembling. Use only "factory made" gaskets. Lock rings are often damaged when removing them. It is advisable to install a new lock ring when assembling pump. Make sure ring is engaged and seated in retaining groove.

On late models, oil hose connections have one piece band type clamps and must be replaced each time hoses are connected. Use pincer tool to squeeze clamps tight as shown in Fig. 3D-1B.

#### VALVE TAPPETS AND GUIDES

##### GENERAL 1953 - 1957

The tappet assembly consists of tappet, roller and hydraulic unit. The tappet and roller, under compression force from valve spring, follow the surface of the revolving cam. The linear motion produced is transmitted to the valve stem by the hydraulic unit, push rod and rocker arm. The hydraulic unit contains a piston or plunger and cylinder plus a ball check valve which allow the unit to pump itself full of engine oil to take up all play in the entire valve train.

When hydraulic units are functioning properly the assembly operates with no tappet clearance. The

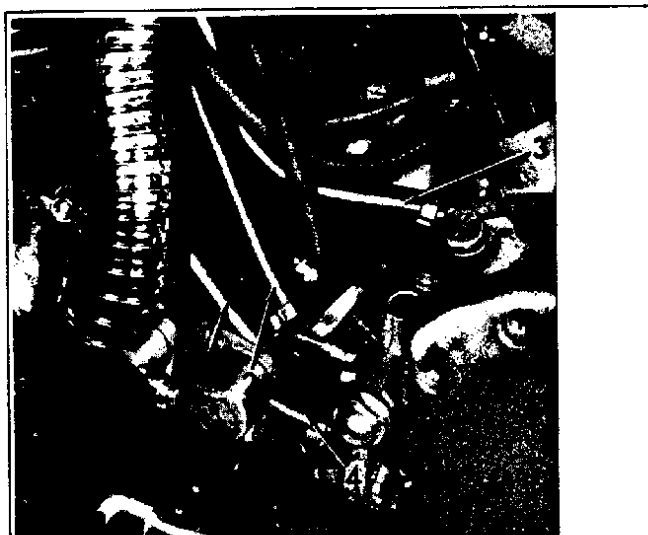

1. Oil supply line from tank
2. Oil return line to tank
3. Vent line to oil tank
4. Front chain oiler line to chain housing

Figure 3D-1A. Oil Pump and Connecting Lines

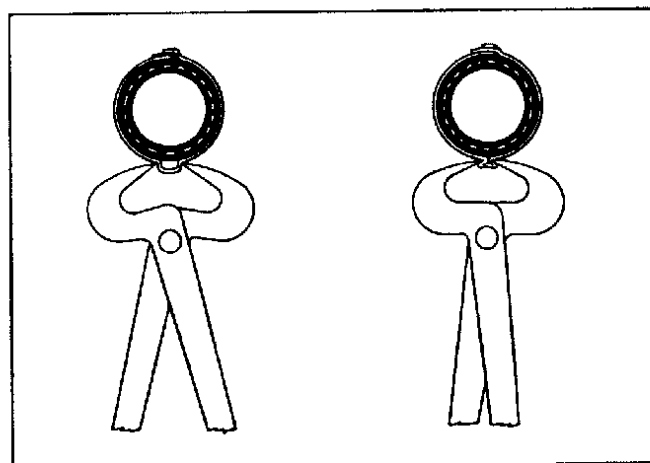

Figure 3D-1B. Hose Clamp Connection

units automatically compensate for heat expansion to maintain a no-clearance condition.

It is normal for tappets to click when engine is started after standing for some time. Hydraulic units have a definite "leak down" rate which permits the oil in the hydraulic unit cylinder to escape. This is necessary to allow units to compensate for various expansion conditions of parts and still maintain no-clearance operation. Push rod assemblies are functioning properly if they become quiet before or as engine reaches full operating temperature.

#### DISASSEMBLING TAPPETS (Fig. 3D-2)

If engine cylinder head is not disassembled, remove push rod cover spring cap retainer. Lift push rod covers and retract push rod adjusting screw until push rod may be lifted out of ball sockets.

Turn out tappet guide screws (1). Lift out hydraulic units (2). Loosen tappet guides by tapping gently with rawhide or soft metal hammer. Insert thumb and forefinger into push rod opening in tappet guide and press tops of tappets against side of guides.

Remove tappet and guide assembly. Be careful to avoid dropping a tappet through guide mounting hole and into gearcase. Slip push rod cover cork washers (3) out of top of tappet guide (4). Pull tappet and roller (5) out bottom of tappet guide and remove tappet guide gasket (6).

#### CLEANING AND INSPECTION

Wash all parts except hydraulic units and gaskets in grease solvent. Hydraulic unit parts are selectively

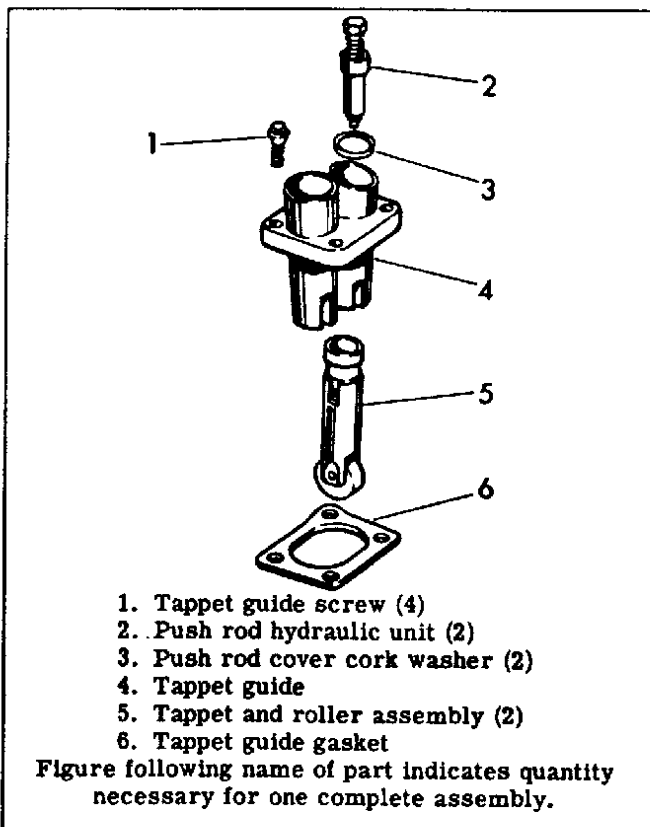

Figure 3D-2. Tappet Assembly - Exploded View

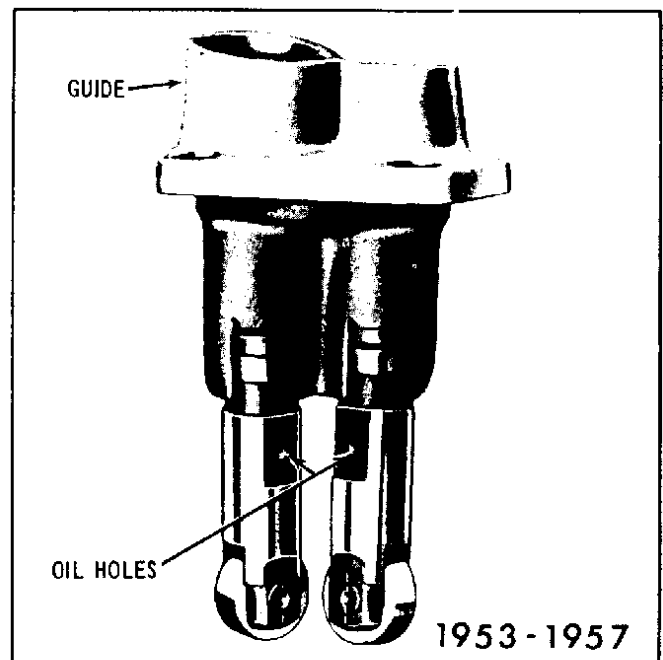

Figure 3D-3. Inserting Tappets on Guide

fitted and may not be interchanged so they must be individually and separately washed. Twist and pull hydraulic piston and spring from cylinder and wash parts.

Blow out oil passages in tappets, tappet guides and hydraulic units with compressed air. Insert a length of wire into oil channel openings in tappet guide to make sure passages are open. Air dry all parts.

Examine cams through tappet guide holes in gearcase for nicked, grooved or chipped condition. Examine tappet-guide matching surfaces for scuffing or grooving.

When tappet fit in guide exceeds maximum tolerance shown in "Engine Specifications" by .001 in. or more, replace worn parts. If roller is loose, force out pin on arbor press, insert new parts and peen or stake pin ends.

Check roller end clearance. Replace all units exceeding tolerances listed in specifications.

#### CHECKING HYDRAULIC UNITS (2, Fig. 3D-2)

Hydraulic units may be checked as follows: Wash and air dry piston and cylinder. Blow out cylinder from bottom to make sure ball and seat are dry. Insert piston in cylinder. Hold in an upright position and press down piston, until spring touches cylinder, without covering hole in bottom of cylinder. Hold for count of 6 and release. If piston bounces back, unit is serviceable. If piston does not bounce back, cover hole in bottom of cylinder and repeat above process. If piston does not bounce back, unit is worn and must be replaced. If piston bounces back, ball is not seating, and unit should be replaced. Before replacing hydraulic units, check possibility of plugged or partially plugged screen under large cap screw located near rear tappet guide. Remove screen as described

in "Disassembling Gearcase," and operate engine without screen and cork washers long enough to compare results.

#### ASSEMBLING TAPPETS (Fig. 3D-2)

Assemble tappets as follows: Slip tappets (5) into guide (4) so flat surfaces on tappets are toward center of guide as shown in Fig. 3D-3. If flat surfaces with holes are not toward center of guide, engine oil will not feed across and one hydraulic unit cannot fill

with oil. Assemble tappet guide gasket dry and insert tappet assembly in place on gearcase, holding tappets in place with thumb and forefinger as when unit was removed.

Assemble push rod cover cork washers, push rod hydraulic units and tappet guide screws.

Assemble remainder of push rod assembly in same order disassembled.

Adjust tappet clearance as described in Section 3B-5.

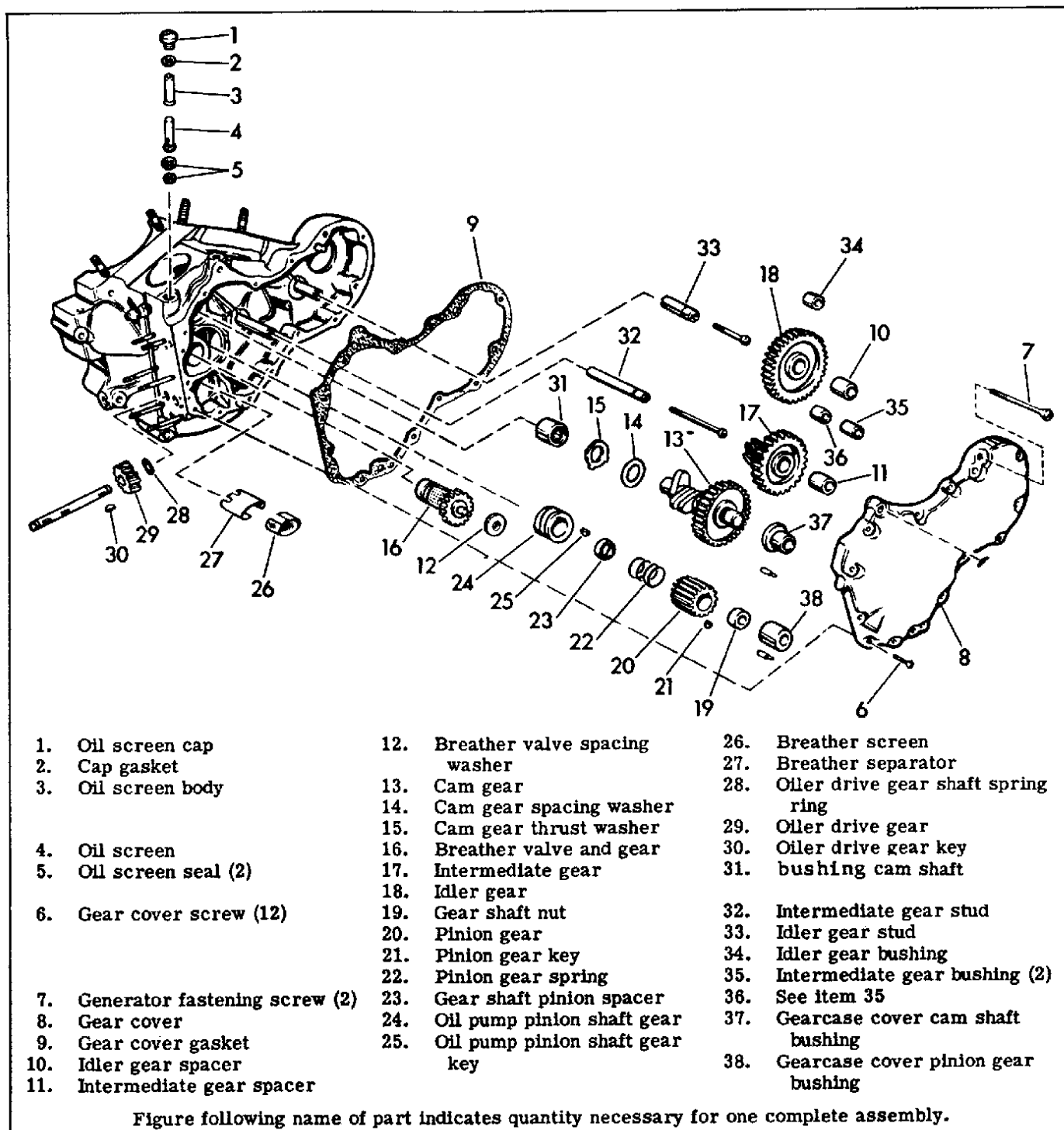

Figure 3D-4. Gearcase - Exploded View

## GEARCASE TIMING GEARS

### GENERAL

1954-1957

The gearcase, located on the right side of the engine crankcase, contains a train of gears which transmit engine power to the cam shaft, crankcase breather, timer, oil pump and generator. The gearcase is lubricated with engine oil through the by-pass circulatory system and through the breather valve from engine crankcase.

All gear shafts run in bushings

The circuit breaker (timer) gear and intermediate gear turn on stationary shafts and are fitted with bronze bushings.

### DISASSEMBLY (Fig. 3D-4)

Before disassembling gearcase, it is advisable to remove push rods, tappets, push rod hydraulic units and tappet guides as described in "Disassembling Tappets."

Remove oil screen cap (1), gasket (2), screen body (3) screen (4), and screen seal (1 or 2 used) (5). Remove screen from screen housing by rotating screen until notch in screen lines up with key in housing.

Remove 12 gearcase cover screws (6), and two long generator fastening screws (7), and remove generator.

Remove two timer-to-motor bolts and slip timer assembly out top of gearcase.

Tap gearcase cover with wood or rawhide mallet to loosen and remove gearcase cover (8) and gearcase cover gasket (9).

Remove idler gear spacer (10) and circuit breaker drive and intermediate gear spacer (11). Make a mark on one of the spacers to insure its assembly to the same gear. The spacers look identical but one may be thicker than the other.

Remove breather valve spacing washer (12).

Remove cam gear (13), spacing washer (14), and thrust washer (15).

Remove breather gear (16), intermediate gear (17) and idler gear (18).

Remove pinion gear shaft nut (19) which has a left-hand thread. Use Gear Shaft Nut Socket Wrench, Part No. 94555-55. Pull pinion gear (20) using Pinion Gear Puller and Installer, Part No. 96830-51 as shown in Fig. 3D-5. Tool has lefthand threads.

Remove key (21). Slip off spring (22), gear shaft pinion spacer (23), oil pump pinion shaft gear (24) and key (25).

Slip breather screen (26) and separator (27) out of pocket in gearcase.

Remove oiler drive gear shaft spring ring (28), oiler drive gear (29) and oiler drive gear key (30).

If necessary, remove oil pump stud nuts and washers and remove oil pump from gearcase. See "Disassembling Oil Pump."

### CLEANING AND INSPECTION (Fig. 3D-4)

Wash and air-dry all parts. Wash inside of case. If crankcase is to be disassembled, wash parts after complete disassembly. If it is not to be repaired, be careful to get no grease solvent into crankcase when washing gearcase.

Inspect oil screen (4) carefully to make sure mesh is open. Holding screen to light is not an absolute check. It is possible for oil screen to be plugged or partially plugged with tiny lint-like fibers and still permit light to pass. Replace plugged or partially plugged screen. Probe oil screen hole in gearcase with a length of wire formed to a short hook to determine if there are any additional oil screen seal gaskets (5) in hole. More than the prescribed number will block off oil feed channel when screening unit is assembled.

Inspect breather screen (26). It must be clean and unobstructed.

Inspect cam gear and pinion gear bushings (37 and 38) in gearcase cover for pitting, scuffing and grooving. Determine amount of pinion and cam shaft wear in cover bushings. If it exceeds maximum tolerance shown in "Engine Specifications, by .001 in., install new bushings.

Inspect intermediate and idler gear fit on respective shaft. Examine bushings (34, 35, and 36) and stud shaft for pitting, grooving or scuffing. If amount of wear exceeds maximum tolerance shown in "Engine Specifications" by .001 in., replace bushings and/or stud shafts (32 and 33).

Attach dial indicator to gearcase cover mounting screw hole and determine amount of pinion shaft play in right main roller bearing. When tolerance in "Engine Specifications" is exceeded by .001 in., bearings should be replaced.

**VALVE TAPPET CAGE** — Install brass tappet plugs # 18529-55 in oil drain holes. This prevents engine from smoking at idle speed. (Started engine # 55 FL 4126). If plugs are not available, use solid plug and drill with 60 drill.



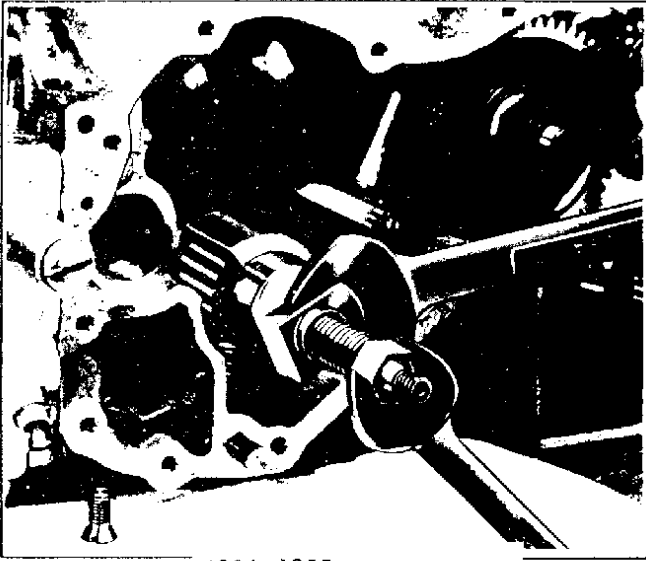

1954-1957

Figure 3D-5. Pulling Pinion Gear

Inspect gears for wear. Assemble pinion and cam gears to respective positions in gearcase. Mesh is considered ideal when no play between gears can be felt and cam gear can be moved back and forth along shaft axis without restriction. Omit cam gear end spacer in assembly for purposes of this check and attach cover with at least four cover screws.

#### REPLACING GEARCASE COVER BUSHINGS (Fig. 3D-4)

Remove pinion shaft cover bushing as follows (Fig. 3D-8)

Use tip of Gear Shaft Bushing Remover, Part No. 96760-36, under hand pressure, to ream old pinion shaft bushing until hole has been enlarged enough



Figure 3D-6. Removing Pinion Shaft Cover Bushing

to turn in smallest tap as shown in Fig. 3D-6. When first tap bottoms against shoulder, bushing may be pulled using puller nut and sleeve. If preferred, bushing may be drilled 5/8 in., tapped and pulled using above tool.

Install new pinion gear shaft bushing (38) in hole in cover as follows:

Position bushing in cover so oil hole in bushing is exactly in line with lubrication channel outlet in cover. Press in bushing on arbor press until top of bushing is flush with cast bushing boss on cover. Locate and center punch new dowel pin location 1/8 in. or more from original location. Drill No. 31 hole 3/16 in. deep. Press in bushing until it bottoms on shoulder in cover boss hole. Continue drilling dowel pin hole to depth of 9/32 in. from top of bushing. Drive in new dowel pin and carefully peen edges of hole to lock pin in place.

To replace cam shaft cover bushing, proceed as follows:

Use Gear Shaft Bushing Remover, Part No. 96760-36, to extract old bushing. Make a mark on outside of bushing boss to locate original dowel pin hole. Press in new bushing with arbor press until shoulder is against cover boss. Locate new dowel pin hole at least 1/8 in. from original hole, centerpunch and drill No. 31 hole exactly 9/32 in. deep. Drive in new dowel pin and peen bushing edges over dowel to secure it.

Drill lubrication oil hole through wall of bushing with 5/32 in. drill, using oil hole in bushing boss as a drill guide.

Pinion shaft and cam shaft bushings must be line reamed to remove burrs and irregularities from hole

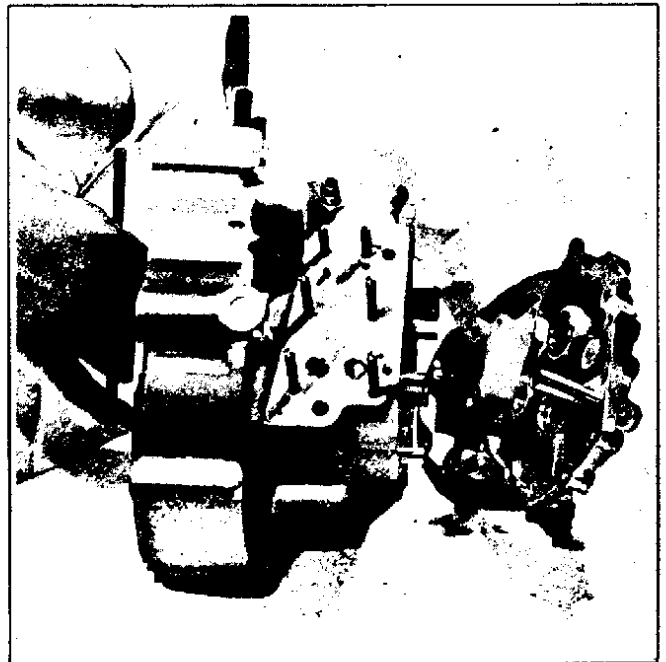

Figure 3D-7. Line Reaming Cover Bushing

and to insure perfect alignment. If crankcase is not disassembled, use any right crankcase side. Fasten cover in place with at least four screws.

To ream pinion shaft bushing, insert reamer pilot in right crankcase roller race. Insert 9/16 in. Pinion Shaft Cover Bushing Reamer, Part No. 94805-57, through pilot and push into cover bushing until it bottoms (see Fig. 3D-7), then give reamer one complete turn to size bushing. Rotate reamer the same direction (clockwise) during extraction.

To ream cam gear cover bushing, insert Cam Gear Shaft Bushing Reamer, Part No. 94802-36, through bushing in crankcase, into cover bushing. Turn reamer until it bottoms in gearcase cover.

Bushings in intermediate and idler gears may be pressed out on an arbor press using a suitable drift pin, and new bushings pressed in.

#### ASSEMBLY

Before assembling gear train, determine amount of end play in breather gear as follows: Assemble breather gear and dry cover gasket to gearcase. Select spacer washer (use washer disassembled unless it is known to give incorrect spacing) and position on end of breather gear. Place a steel straightedge across gearcase at spacer. With thickness gauge, measure distance between straightedge and spacer. Subtract .006 in. (amount gasket will compress) from this figure to determine gear end play. An end play tolerance of .001 to .005 in. is correct. If end play exceeds maximum, insert thicker spacer. Breather valve and gear spacer washers are available .115, .120 and .125 in. thick.

Establish proper cam gear end play as follows: Install thrust washer, spacing washer and cam gear. Position cover gasket and secure cover with at least four screws. Measure cam shaft end play between cam gear and cover bushing with thickness gauge through tappet guide hole in gearcase. End play should be from .001 to .005 in. If measurement is under or over tolerance, remove cover and replace spacing washer with one to give suitable clearance. Cam gear spacing washers are available .050, .055, .060, .065 and .070 in. thick.

Make final gearcase assembly including all parts in approximate reverse of disassembly order. Breather, cam, pinion and intermediate gears contain timing marks which must be aligned or matched as shown in Fig. 3D-8. Rotate gear train and note if it revolves freely. A bind indicates gear are meshed too tightly. Make sure intermediate and idler gear spacers are assembled to their respective shafts.

Apply a coat of non-hardening gasket sealer to crankcase and cover gasket surface. Position new cover gasket and secure cover with all cover screws. Pour about 1/4 pint of engine oil over gears to provide initial lubrication before securing cover.

Assemble remainder of gearcase, generator and circuit breaker in reverse of order removed.

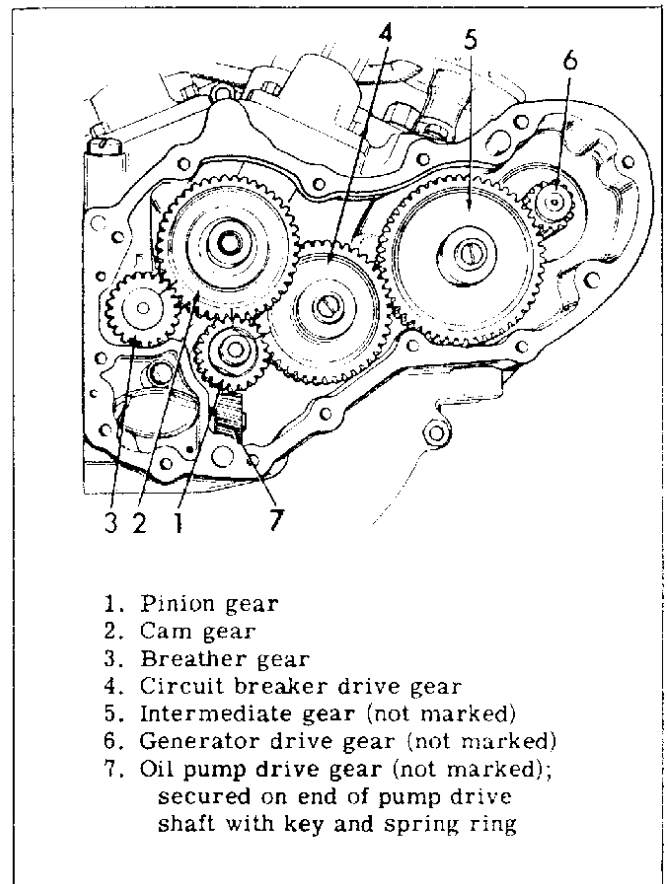

Figure 3D-8. Timing Gears with Timing Marks Aligned

#### PINION SHAFT

Pinion shaft for 55 thru 57 FL-FLH identified by paint marked around center, and snap ring groove at outer edge of roller bearing surface. Part # 24006-55

If pinion shaft # 24006-55 is not available, early model shafts # 24007-39 or # 24006-54A can be used. Change right side case bushing to Early model # 24599-40. All related shaft parts must be changed to match the shaft used.

## CRANKCASE

### GENERAL

## 1955-1957

When rod bearings, pinion shaft bearings or sprocket shaft bearings are in need of repair, the engine must be removed from the motorcycle as described in "Stripping Motorcycle for Engine Repair," Section 3A. It is recommended procedure to check and make repairs to cylinder heads, cylinders and gearcase at the same time, or in other words, perform an entire engine overhaul.

#### Flywheel End Play Check:

Before starting crankcase disassembly, check flywheel assembly end play to determine sprocket shaft bearing wear using a dial indicator. Assemble engine sprocket and nut or compensating sprocket to sprocket shaft before taking reading to assure accurate measurement. Attach indicator securely to crankcase with indicator stem resting on end of sprocket or pinion shaft. Rotate flywheels and work all end play to one end of assembly. Adjust dial indicator, rotate flywheels and work assembly to other extreme. If play exceeds tolerance (see "Engine Specifications, replace entire sprocket bearing set.

#### DISASSEMBLING CRANKCASE

Remove cylinder heads as described in "Disassembling Cylinder Head,"

Remove cylinders as described in "Disassembling Cylinder,"

Remove gearcase parts as described in "Disassembling Gearcase," See "Crankcase," above for checking procedure before starting crankcase disassembly.

Refer to Fig. 3E-1 and proceed as follows:

Remove crankcase bolt (1), stud (2), crankcase breather stud assembly (3) or (3A), stud (4), top and right crankcase studs (5) and two lower crankcase studs (6). It is necessary to remove only one stud nut and slip stud and other nut out opposite side of crankcase.

Refer to Fig. 3E-2 and continue disassembly:

Position crankcase with gearcase (right side) up. Tap crankcase with rawhide or soft metal mallet to loosen top half. Lift right crankcase half (1) off pinion shaft main bearings. Remove spiral lock ring (2) from pinion shaft with tip of screwdriver. Lift bearing washers (3 and 5) with bearings and bearing retainers (4) off pinion shaft.

Remove sprocket shaft spacer (6) secure pinion shaft end of flywheels in copper vise jaws and turn out sprocket shaft bearing nut (7) with Sprocket Shaft Bearing Nut Wrench, Part No. 97235-55A (Fig. 3E-4). Thread is lefthand.

Mount flywheel and left case assembly on press table supporting case on parallel bars (Fig. 3E-5) and press

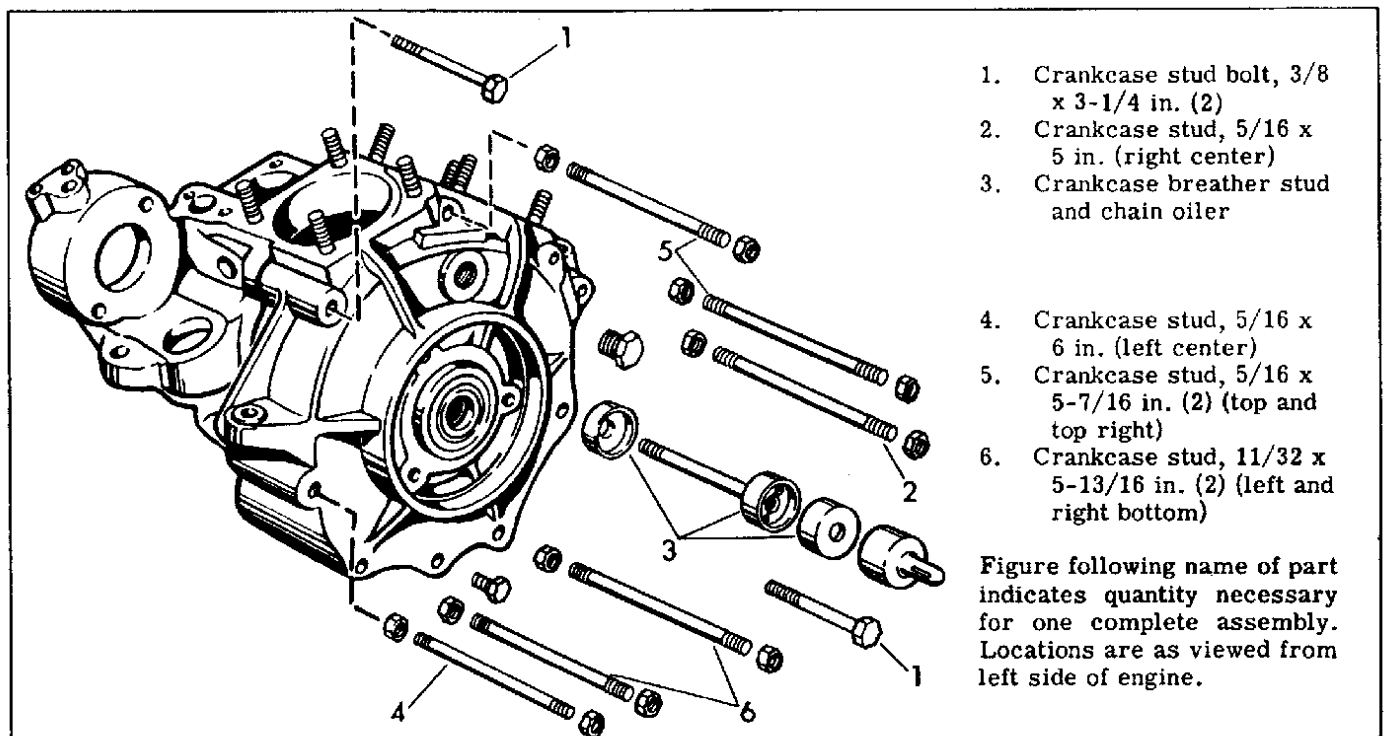

1. Crankcase stud bolt, 3/8 x 3-1/4 in. (2)
2. Crankcase stud, 5/16 x 5 in. (right center)
3. Crankcase breather stud and chain oiler
4. Crankcase stud, 5/16 x 6 in. (left center)
5. Crankcase stud, 5/16 x 5-7/16 in. (2) (top and top right)
6. Crankcase stud, 11/32 x 5-13/16 in. (2) (left and right bottom)

Figure following name of part indicates quantity necessary for one complete assembly. Locations are as viewed from left side of engine.

Figure 3E-1. Crankcase Studs - Exploded View

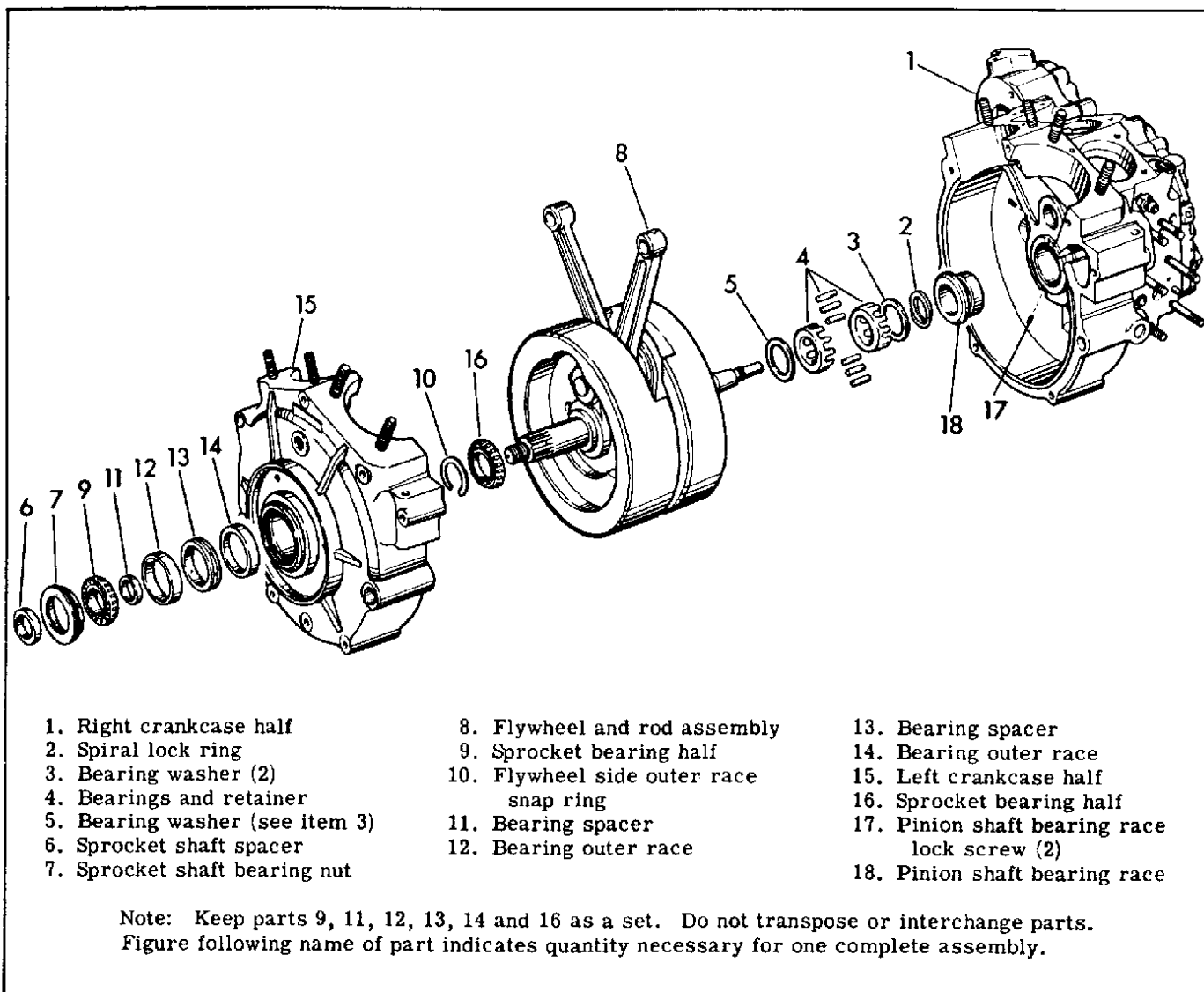

Figure 3E-2. Crankcase - Exploded View

on end of sprocket shaft with arbor press until flywheel assembly (8) drops out, freeing sprocket side bearing half (9) and spacer (11).

Remove flywheel side outer race snap ring (10) from groove in case by prying end with screwdriver and inserting thin screwdriver or knife blade between snap ring and case.

Reposition case on press table and press out outer races (12 and 14) and bearing spacer (13) from case (15) using Sprocket Shaft Bearing Outer Race Press Plug, Part No. 97194-57 (Fig. 3E-6).

If flywheels are to be disassembled, grip pinion shaft in vise and pull bearing from sprocket shaft using the Bearing Puller Part No. 96015-56. Place hooked ends of puller halves behind bearing and hold collar over puller halves. Engage puller screw cross in puller slots and pull bearing off by tightening puller screw against sprocket shaft center as shown in Fig.

3E-7. Keep bearings (9 and 16) in a set with proper bearing outer races (12 and 14).

#### DISASSEMBLING FLYWHEELS (Fig. 3E-8)

Grip pinion shaft in copper covered vise jaws so shafts are in vertical position. Insert a rod about 5 in. long and 1/2 in. in diameter through holes in flywheels to keep them from turning. Remove lock plate screw (1), lock plate (2) and crank pin nut (3). Strike left flywheel with soft metal mallet at about 90 degrees from crank pin hole on wheel periphery to loosen. Lift left flywheel (4) off crank pin.

Hold down bearing assembly with a short length of pipe or tubing so connecting rods (5) may be slipped off bearings. Remove bearings (6). Hold together in set until bearings are washed and refitted to crank pin.

Remove lock plate screw (7), lock plate (8) and gear shaft nut (9). Tap pinion shaft (11) out of flywheel (10). Remove key (12) from shaft.

Clamp crank pin in vise. Remove lock plate screw (13), lock plate (14) and crank pin lock nut (15). Tap crank pin (16) out of flywheel and remove key (17).

Grip sprocket shaft in vise and remove lock plate screw (18), lock plate (19) and sprocket shaft lock nut (20). Remove sprocket shaft (21) by tapping it out of flywheel, and remove key (22).

#### CLEANING AND INSPECTION

Wash all parts in grease solvent and blow dry with compressed air. Examine crank pin for wear, grooving and pitting. If the surface is at all worn, replace with new pin. Examine flywheel washers (23 and 24). If either washer is worn and grooved, it should be renewed.

Examine connecting rod lower races. If they appear slightly grooved or shouldered where edge of bearing rollers ride, they may be lapped out and oversize bearing rollers installed. If they appear badly worn, grooved or pitted, the rods may be returned to the factory through any authorized Harley-Davidson dealer for repair, straightening and refitting with new bearings and piston pin bushings.

Examine pinion shaft and right crankcase bushing (see 18, Fig. 3E-2) for pitting, grooving and gouging at point where right main roller bearings ride. A shaft that is worn must be replaced. If bushing is worn beyond repair, replace as described in "Truing and Sizing Pinion Shaft Main Bearing."

Examine sprocket shaft outer races for wear, grooving, and pitting. Examine bearing rollers for wear, pitting, grooving and heat discoloration. The sprocket shaft Timken tapered roller bearings are manufactured in selectively fitted sets. The same serial

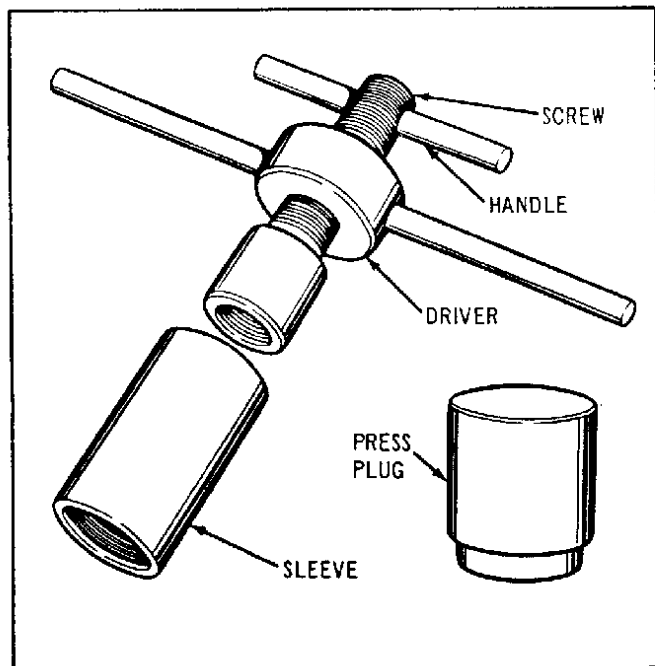

Figure 3E-3. Sprocket Shaft Bearing Installing Tools

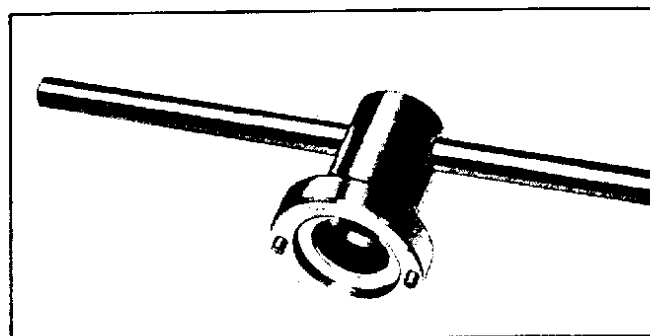

Figure 3E-4. Sprocket Shaft Bearing Nut Wrench

number appears on all parts. If any part is unusable, the complete set must be replaced.

#### REPLACING FLYWHEEL WASHERS

Replace worn flywheel washers as follows:

Washer is a close fit in recess in flywheel and is secured originally by punching flywheel metal tight against the washer at several points. It is usually necessary to drill a small hole (1/8 in. or smaller) at the outer edge of the washer to permit getting a pointed tool underneath to pry it out. The hole is drilled only slightly deeper than the thickness of the washer to avoid removing more metal than necessary.

Before installing new washer, scrape outer edge of washer recess where metal was punched against it so new washer may seat fully against recess bottom. If washer does not seat fully, forked rod is not likely to have necessary clearance for side play.

#### LAPPING CONNECTING ROD RACES

Connecting rod lower races that are likely to clean up within the range of oversize bearing rollers and are otherwise in serviceable condition, should be trued and sized with Connecting Rod Lapping Arbor, Part No. 96740-36, as shown in Fig. 3E-9.

Turn lap in lathe at 150 to 200 rpm. Adjust lap by means of adjusting nut to a dragging but free fit in rod race. Clean lap before using, then apply fine lapping compound (No. 220 grit grinding compound mixed with oil) to lap. A loose or tight lap will "bell mouth" bearing race so it must be kept adjusted at all times. To avoid grooving or tapering lapped surface in rod, work rod back and forth the full length of the lap holding rod as near race end as possible. Lap rods individually.

When rods are lapped true and all traces of pit marks or grooving are cleaned up, wash rods and blow dry. Surface should have a soft velvety appearance and be free of shiny spots. Assemble crank pin on right flywheel (see "Fitting Rod Bearings" before assembling flywheels). Wipe pin taper and flywheel taper perfectly clean and free from oil. Insert key in keyway and position flywheel over pin held in vise. Tighten nut very tight using Crank Pin and Flywheel Nut Wrench Part No. 94545-26. If necessary, tighten nut

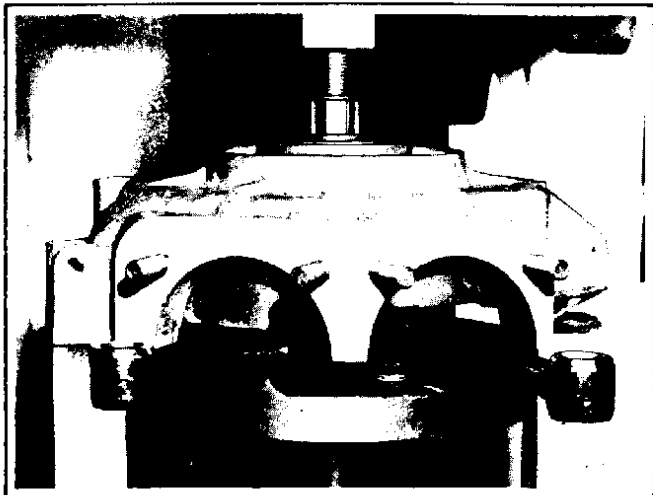

Figure 3E-5. Pressing Flywheels Out of Crankcase

to make lock plate notches line up with corners of the nut with the lock washer screw hole in alignment. Never loosen nut to achieve this register. Never use length of pipe over handle of crank pin nut wrench. Handle length has been determined by strength of average man and is designed to give nut suitable tension with only this specific handle length used.

Assemble pinion shaft to right flywheel, with the Crank Pin and Flywheel Nut Wrench.

#### FITTING ROD BEARINGS

There are three ways to determine oversize rollers to use. All will result in properly fitted bearings if applied correctly.

1. Use a micrometer to measure the outside diameter of the crank pin at its center. Use an inside micrometer or telescoping hole gauge to measure the inside diameter of the rod races. Subtract the diameter of the crank pin from the inside diameter of the bearing race. Subtract from this figure the standard

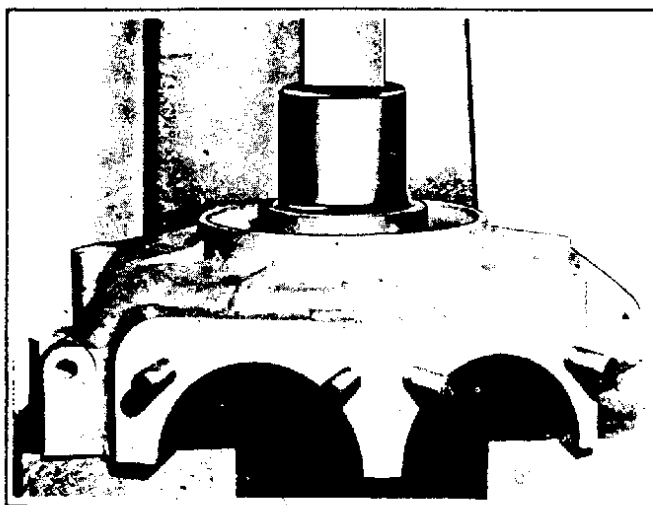

Figure 3E-6. Pressing Bearing Races Out of Crankcase

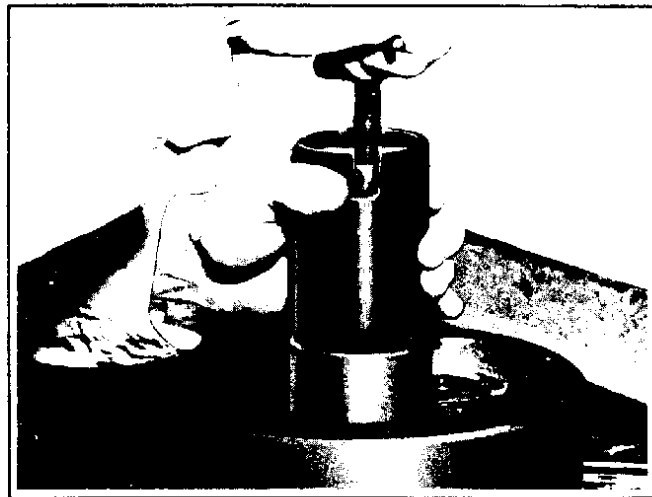

Figure 3E-7. Pulling Bearing from Sprocket Shaft

allowance for bearing running fit size. This answer, divided by two will give proper roller size. To find oversize amount of bearing, subtract from this figure the diameter of a standard roller.

#### Example:

The rod bearing race measures 1.6263 in. after lapping and truing. The crank pin is slightly worn and measures 1.2485 in. Subtract 1.2485 in. from 1.6263 in. The answer, .3778 in., represents the diameters of both rollers (one on each side) plus clearance for running fit. Subtract minimum clearance for running fit (.001 in.). The answer (.3768 in.) is then divided by two to get the diameter of each oversize roller. In this case it would be .1884 in. To find how much oversize each roller must be, subtract from this figure the diameter of a standard roller, or .1875 in. Rollers must be .0009 in. oversize.

2. Install any new set of oversize rollers to bearing races and position on crank pin. Slip rods over bearings. If they will not fit, it is obvious rollers are too large and a smaller size must be tried. If they fit and spin freely, install a larger set of rollers. Try various roller sizes until the rods will turn with a very slight drag. This is a plug fit. Determining running fit is merely a matter of subtracting one half the desired running fit clearance (.0005 in.) from the roller size to find the running fit roller size.

It may be easier to gauge a plug fit as follows:

3. Fit any size rollers into races. Position bearings in rods. Support rods and bearings with left hand. Drop crank pin (not attached to flywheel) through crank pin hole. Plug fit has been achieved when crank pin will slide slowly through hole from its own weight. Running fit is then determined by subtracting one half running clearance from oversize of rollers used to make plug fit.

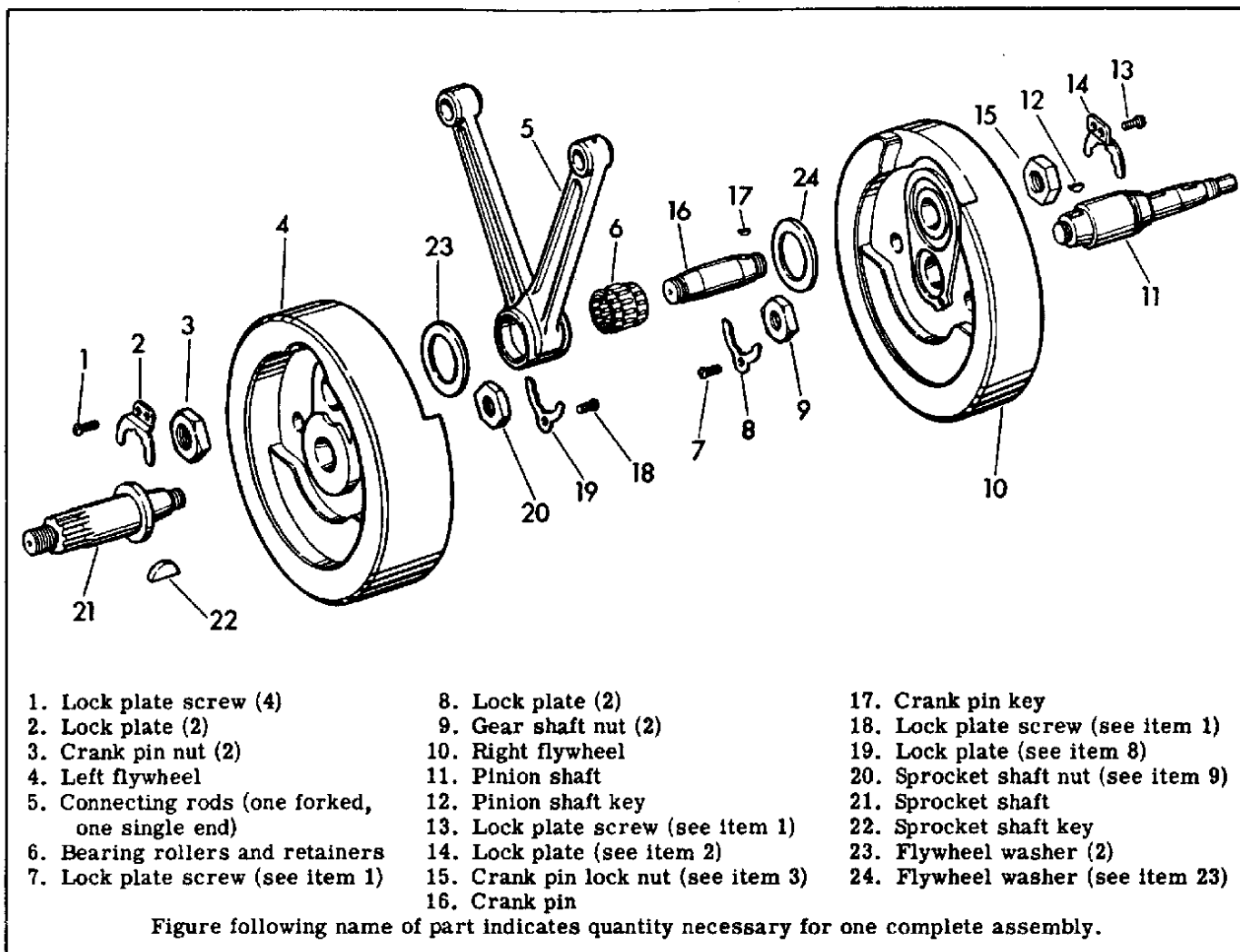

Figure 3E-8. Flywheel Assembly - Exploded View

**Example:**

Plug fit is achieved with .0009 in. oversize rollers. By subtracting from this one half the minimum clearance (.0005 in.) it is determined that a .0004 in. oversize roller set will give desired running fit.

If lower end race of one rod is found to be slightly larger than the other, select rollers to fit the larger rod race and lap smaller rod race to same size as larger race rather than fitting rollers of two sizes.

When rods are correctly fitted with required bearing clearance, extreme upper end of female (forked) rod will have just barely noticeable side shake while the upper end of the male rod will have .025 in. to 1/32 in. (.031 in.) side shake. All fitting and checking must be made with bearings, rods and crank pin clean and free of oil.

Fitting bearings tighter than described may result in seizing and bearing damage when heat expands parts.

Check overall width of roller retainer assembly. It must be less than width of female rod end.

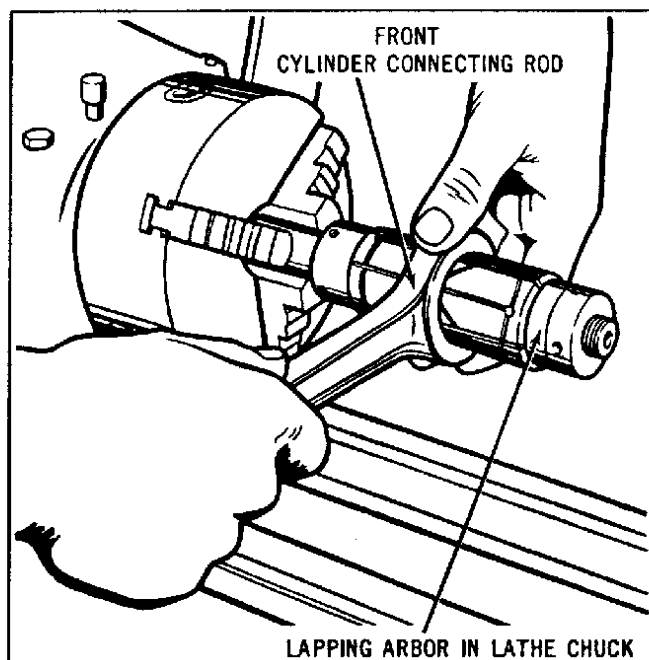

Figure 3E-9. Lapping Connecting Rod Bearing Race

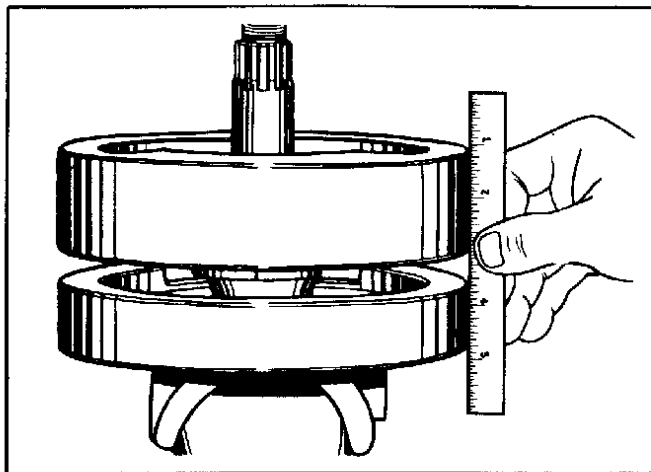

Figure 3E-10. Squaring Flywheel Faces

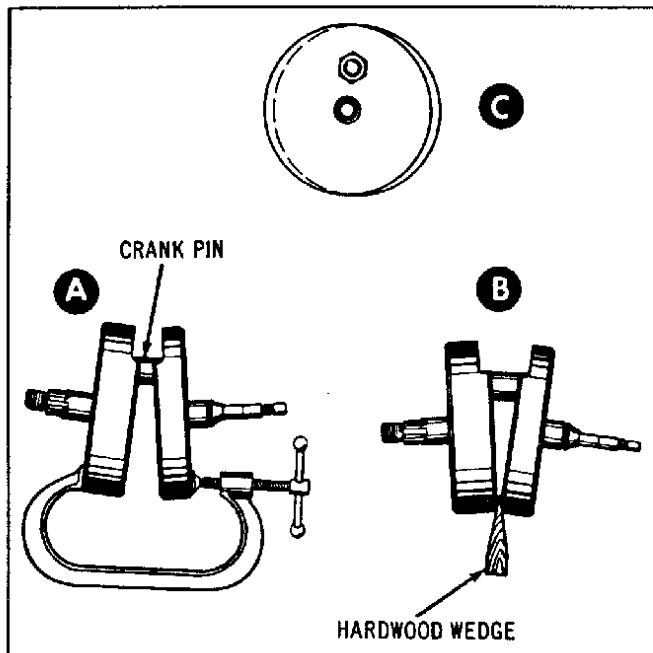

Figure 3E-11. Correcting Flywheel Alignment

#### ASSEMBLING FLYWHEELS

After correct connecting rod bearing fit has been attained, clean and assemble parts as follows: Install sprocket shaft to left flywheel and pinion shaft and crank pin to right flywheel. Check to make sure oil passages through pinion shaft, right flywheel and crank pin are clear by blowing compressed air into hole near end of pinion shaft.

Position right flywheel assembly in vise, crank pin up. Wipe crank pin taper clean. Slip bearings and connecting rods over crank pin with forked rod to rear cylinder. Wipe crank pin hole in left flywheel clean and dry. Install left flywheel and tighten nut lightly. Hold steel straightedge along outer face of wheel rims at 90 degrees from crank pin as shown in Fig. 3E-10. Tap outer rim of top wheel until wheels are concentric. Tighten nut. Recheck with straightedge at frequent intervals. Use soft metal

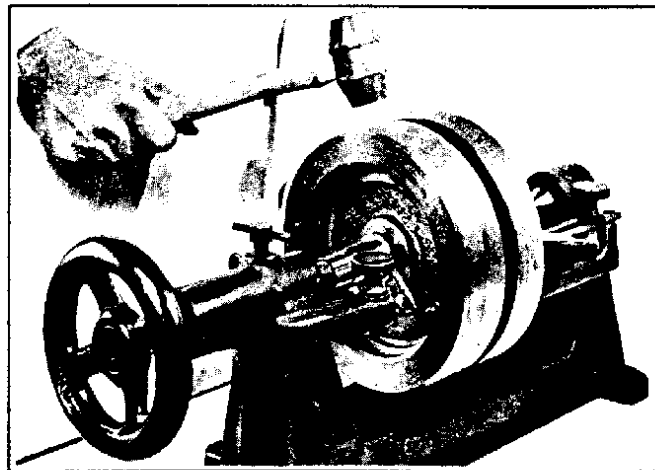

Figure 3E-12. Truing Flywheels on Truing Stand

hammer to realign wheels. To prevent flywheel assembly from turning in vise while tightening nut, insert a rod 5 in. long and about 1/2 in. in diameter through holes in flywheels and between vise jaws so that rod bears against some part of the vise.

When nut is fairly tight, install flywheel assembly in Flywheel Truing Device, Part No. 96650-30. Adjust so centers are snug. Wheels must turn freely but shafts may not be loose in centers. If flywheel assembly is either loose or squeezed, indicators will not indicate accurately. Adjust indicators to take reading as near to flywheels as possible, so pointers read at about the middle of the scales.

Turn flywheels slowly and observe the movement of indicator pointers. Movement toward flywheels indicate high points of shafts. Find highest point of each shaft and chalk-mark flywheel rims at those points. Loosen centers slightly, just enough so looseness may be detected, and make corrections as follows:

Flywheels may be out of true three ways, A, B and C, Fig. 3E-11 or a combination of two of the three ways.

When wheels are both out of true as indicated in "A," tighten a C-clamp on rims of wheels opposite crank pin and lightly tap the rim at the crank pin with lead or copper mallet.

When wheels are both out of true as indicated in "B," drive a hardwood wedge between the wheels opposite the crank pin and lightly tap the rims near the crank pins with a mallet.

When wheels are out of true as indicated in "C," strike the rim of the wheel a firm blow at about 90 degrees from crank pin on high side (see Fig. 3E-12).

When wheels are out of true in a combination of any of conditions shown, correct A or B first, tapping rim of offending wheel only, and then correct condition C.



The number of blows required and how hard they should be struck depends on how far shafts are out of true and how tight nuts are drawn. Remember that centers must be loosened slightly before striking flywheels. Making them too loose may result in damaged centers. Never strike wheels a hard blow near crank pin. This could result in a broken crank pin.

Readjust centers, revolve wheels and take reading from indicator. Repeat truing operation until indicated run out does not exceed .001 in. (each graduation on indicator is .002 in.).

If it is impossible to true wheels, check for a cracked flywheel, damaged or enlarged tapered hole, or a sprocket or pinion shaft worn out of round at surface where indicator reading is being taken. When wheels are true, position in vise and draw crank pin nuts very tight using Crank Pin and Flywheel Nut Wrench, Part No. 94545-26. Check connecting rod side play with thickness gauge as shown in Fig. 3E-13. If it is greater than tolerance shown in "Engine Specifications," Section 3A, draw up crank pin nuts until within tolerance. Insufficient play between rods and flywheel face is caused by one of following conditions:

1. Flywheels and crank pin assembled with oil on tapers and nuts over-tightened. Disassemble, clean, reassemble.
2. New flywheel washers installed and not fully seated. Disassemble, inspect, replace deepest seating flywheel or exchange crank pin. As last resort, grind down width of forked rod.
3. Taper holes enlarged as a result of having been taken apart several times. Replace wheel seating deepest.
4. Cracked flywheel at tapered hole. Replace flywheel.

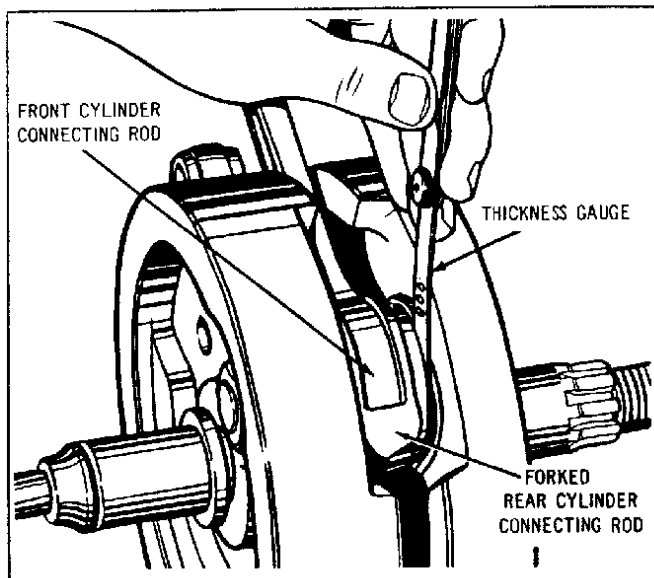

Figure 3E-13. Checking Connecting Rod Sideplay

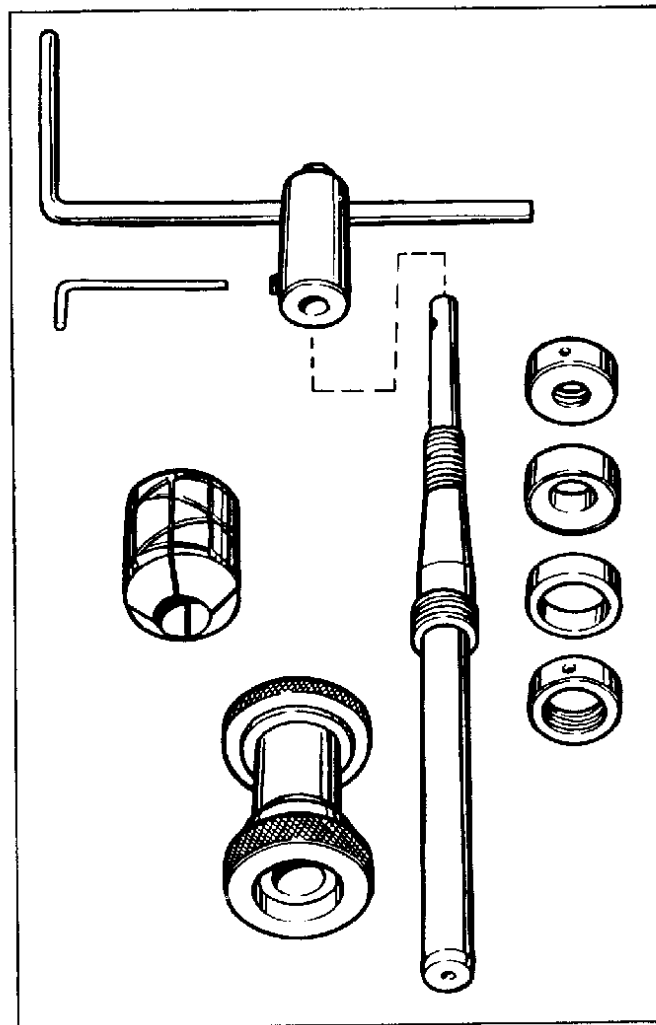

Figure 3E-14. Main Bearing Lapping Tools

If sides of forked rod are ground to get desired clearance, backs of bearing retainers must be ground down to remain narrower than width of female rod.

After rod sideplay is checked and adjusted, crank pin nut pulled very tight and lock plate and screw installed, again recheck wheel trueness on truing device. Correct any run-out as above.

#### TRUING AND SIZING PINION SHAFT MAIN BEARING

Before fitting new pinion shaft main bearings, lap bearing race in crankcase to true it and remove traces of wear shoulder at sides of roller paths. Using Crankcase Main Bearing Lap, Part No. 96718-54, consisting of lapping shaft, handle, lapping arbor and guide sleeve (Fig. 3E-14).

A race that is worn beyond limits of oversize bearings must be replaced. To remove worn bearing race, remove two bearing race lock screws (17, Fig. 3E-2) from inside of case. Heat case to 275 - 300 degrees F. Heating expands case and makes it possible to remove bearing race using less force. Press worn race (18, Fig. 3E-2) out and new race in. New race must be lapped slightly to true and align

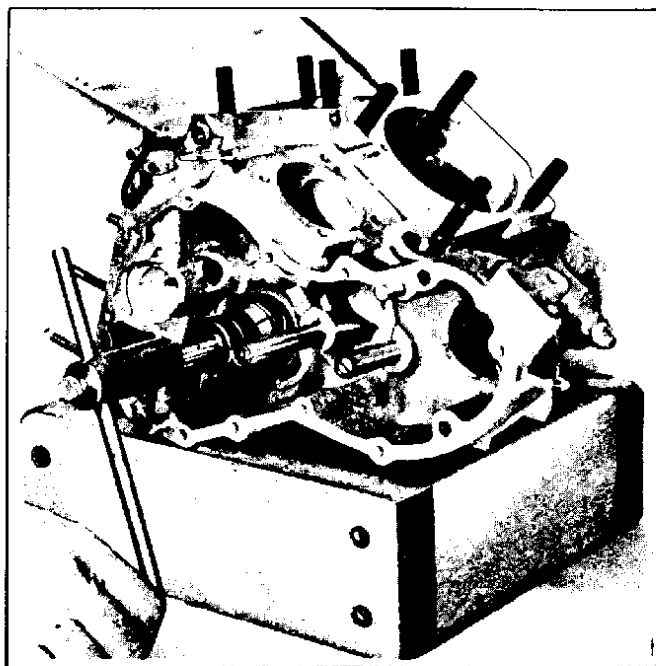

Figure 3E-15. Lapping Pinion Shaft Main Bearing Race

with left case bearing, and to attain a size compatible with roller sizes available.

**LAPPING ENGINE MAIN BEARINGS** (Fig. 3E-15). Secure right and left crankcase halves with three crankcase stud bolts (top center and bottom left and right). The sprocket shaft bearing outer races and large spacer must be installed in left crankcase.

Assemble lapping arbor to lapping handle and assemble guide sleeve to sprocket shaft bearing bushing. Sleeves for use with tapered bearing, are assembled to case with bearings and small spacer collar. Turn sleeve parts finger tight.

Insert lap shaft with arbor assembled through pinion bearing bushing and into guide sleeve. Tighten arbor expansion collars using a length of 5/32 in. rod as spanner until arbor begins to drag. Do not adjust arbor snug in bushing or bushing will "bell," a condition where hole is larger at ends than it is in the center.

Withdraw arbor far enough to coat lightly with fine lapping compound. Do not apply a heavy coat. Reposition lap in bushing and turn handle at moderate hand speed. Work lap back and forth in bushing as it is revolved to avoid grooving and tapering.

At frequent intervals, remove lap from crankcase, wash and inspect bushing. Lapping is completed when entire bushing surface has a dull, satin finish rather than a glossy, smooth appearance. If necessary, flush off lap in cleaning solvent, air dry and apply fresh, light coat of fine lapping compound.

#### FITTING PINION SHAFT BEARING

The fitting of pinion shaft bearing is done in much

the same way as fitting lower rod bearings (see "Fitting Rod Bearings"). A plug fit is first determined using the pinion shaft that will be used on engine being overhauled, or spare shaft of exactly same size. When a plug fit has been found, pinion shaft will enter bearing slowly under its own weight, will turn with only a very light drag and will have no perceptible shake.

A running fit is determined from a plug fit by subtracting one half the desired running fit clearance from the size of the plug fit rollers.

#### Example:

Running fit clearance is .0005 to .001 in. loose. See "Engine Specifications," Section 3A. If a plug fit was achieved with .0006 in. oversize rollers, subtract one half running fit clearance from plug fit roller oversize. Use figure representing middle or average of tolerance span, .00075 or .0008 in. One half the average of tolerance (.0004 in.), subtracted from roller oversize (.0006 in.), indicates that .0002 in. oversize rollers should be used to produce a suitable running fit.

Oversize rollers are available in .0002, .0004, .0006, .0008 and .001 in. sizes. All calculations should therefore be made to nearest available even-numbered size. In the example above, it would be possible to arbitrarily decide upon .0006 in. as a running fit rather than the .0008 in. if desired. Final decision would rest largely upon intended use of motorcycle. For highspeed work, the more free fit would be better, while the closer tolerance is suited to road use at average speeds. This consideration may be made in fitting all tolerances.

All fitting must be done with bearings that are clean and dry. Oiled surfaces will take up some clearance and give a false reading.

#### FITTING SPROCKET BEARING

If Timken tapered roller bearings and races pass visual check and have no apparent wear, the same set may be reinstalled. Make certain all parts of bearing are installed in exactly the same order they were removed. If any part of bearing assembly is worn, entire assembly should be replaced.

#### ASSEMBLING CRANKCASE (Fig. 3E-2)

Install flywheel side outer race snap ring (10) in case. Using arbor press and Outer Race Press Plug, Part No. 97194-57 press outer races (12 and 14) and bearing spacer (13) into crankcase bushing one at a time. Press the races into the case with widest ends outward to match taper of bearings. Be sure the first race bottoms on the snap ring and each successive part tight against the one before.

Install bearing (16) spacer (11) on sprocket shaft using bearing tool. Press the parts on using sprocket shaft spacer (11) as a pressing spacer only. Turn tool screw onto sprocket shaft thread and tighten securely. Remove tool handle and slip the bearing

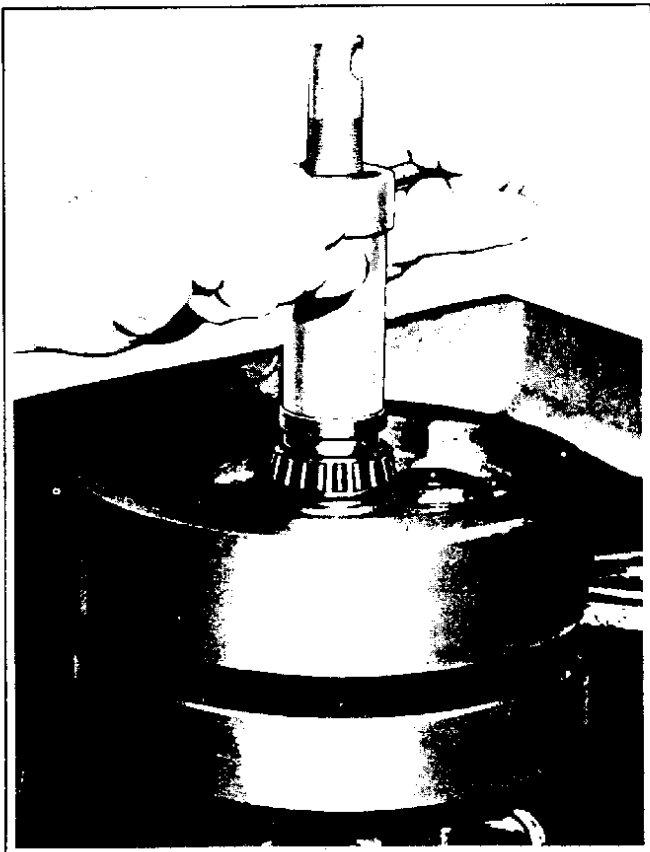

Figure 3E-16. Pressing Bearing on Sprocket Shaft

small end up over sprocket shaft, starting it squarely. Install the small bearing spacer and the sprocket shaft spacer. Place tool sleeve on spacers and press bearing against flange on flywheel using the tool driver and handle as shown in Fig. 3E-16.

Position flywheel assembly in vise with sprocket shaft up. Slip crankcase half (15), with outer race parts installed, over shaft. Slip bearing over tool screw, small end down. Position tool sleeve and turn on driver. Turn driver down against sleeve pressing bearings tightly together as shown in Fig. 3E-17. Bearings must be tight against the bearing spacer to provide correct bearing clearance.

Install bearing lock nut (7) in crankcase using Sprocket Shaft Bearing Nut Wrench, Part No. 97235-55A. Nut should be started by hand. Thread is left hand. Final tightening may be left until case is assembled.

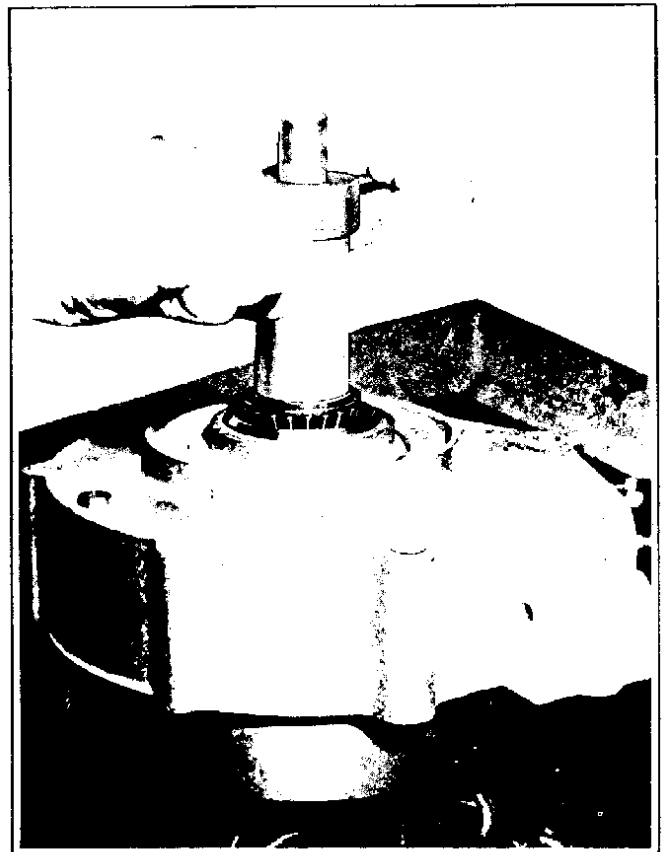

Figure 3E-17. Pressing Flywheel into Crankcase

Remove assembly from vise and install bearing washer (5), bearings (4) and bearing washer (3) to pinion shaft. Install new spiral lock ring (2) to groove in pinion shaft. Slip right case half over bearing and against left case half after applying a coat of non-hardening gasket sealer to parting surfaces.

see Fig. 3E-1. Align case halves and tap crankcase stud bolts (6 and 5) into holes. These two studs properly align the case halves and must be installed before remaining studs. Start nuts and tighten until snug. Insert remaining studs and bolt and tighten all nuts securely.

Tighten sprocket shaft bearing nut. Install sprocket spacer (6, Fig. 3E-2) and sprocket or sprocket shaft extension. Start sprocket nut and tighten securely.

# SHOP DATA:

## 74 CU. IN. O. H. V. ENGINE FITTING SPECIFICATIONS ( 1955 AND LATER MODELS )

PISTON CLEARANCE -- New piston fitted in cylinder, .001" to .002" clearance.  
Piston shapes to cylinder and acquires more clearance after short time in service.

Measure piston at bottom of skirt, front to rear.

Measure cylinder about 1/2" from top of bore, front to rear.

PISTON PIN IN PISTON -- Light hand press fit.

PISTON PIN IN UPPER END OF CONNECTING ROD -- .0008" to .0012" loose.

PISTON RING GAP AND GROOVE CLEARANCE -- With rings inserted 1/2" to 3/4" from top of cylinder -- Solid Type Rings .010" to .020" gap - U-Flex Oil Control Rings 11/32" overlap. Rings should be .004" loose in ring grooves of piston.

LOWER CONNECTING ROD BEARING -- .001" to .0015" loose.

CONNECTING RODS -- .006" to .010" end play between flywheels -- roller and retainer assembly should be narrower, but not more than .010" narrower than forked rod.

SPROCKET SHAFT TIMKEN BEARING --

Sprocket shaft Timken bearings are made up in matched sets. All bearing parts are marked with matching numbers. Do not use bearing parts with different matching numbers. If any part of bearing requires replacing, the entire bearing assembly must be replaced. A complete set of sprocket shaft Timken bearings consists of two inner races with bearings and retainers, one inner bearing race spacer, two outer races, (cones) and one outer race spacer. Inner bearing race spacer determines running clearance between bearings and races.

PINION GEAR SHAFT -- .0005" to .001" loose in roller bearing -- .0005" to .0012" loose in cover bushing. Oil slot in cover bushing is centered with drilled feed oil passage in cover.

FLYWHEEL ASSEMBLY - Sprocket and gear shafts must run true within .001".

CAM GEAR -- .001" to .0015" loose in crankcase and cover bushings -- .001" to .005" end play.

INTERMEDIATE GEARS -- .001" to .0015" loose on studs -- .003" to .007" end play.

TAPPET GUIDES -- .0005" to .001" press fit in crankcase.

VALVE TAPPETS -- .001" to .002" loose in tappet guides.

ROCKER ARM FIT IN BEARINGS -- .001" to .002" loose -- .004" to .012" end play.

OIL PUMP DRIVE SHAFT -- .0008" to .0012" loose in crankcase bushing.

CRANKCASE BREATHER -- .001" to .005" end play -- times with front cylinder -- opens 1/8" before top center to 1/8" after top center, and closes 13/16" to 1-5/16" after bottom center.

# SHOP DATA.

## ROLLER BEARING ROLLER GUIDE

(Supersedes all previous lists)

Here is a handy chart, giving information on roller bearing rollers. It is suggested that this data be kept in a prominent place so that it can be referred to on a moment's notice.

Rollers .250" and .1875" are used in retainers.

Needle rollers .152", .125", .114" and .0625" are used without retainers.

Rollers .250", .1875" and .152" are furnished from .001" undersize to .001" oversize in steps of .0002".

Rollers .125" and .114" are furnished only .0004" and .0006" oversize.

Rollers .0625" are furnished only .0008" oversize.

<u>Part No.</u>	<u>Where Used</u>	<u>No. Used</u>	<u>Length</u>	<u>Std. Dia.</u>
304-15	Forked End Connecting Rod (1915 to 1939 - 61", 74" & 80" Twins)	24	.360"	.250"
"	Left Crankcase (1929 and earlier 61" & 74" Twins)	24	"	"
"	Left Crankcase (1929 and later 45" Twins)	24	"	"
"	Front Brake Hub (1930 to 1936 - 74" & 80" Twins)	24	"	"
"	Sidecar Brake Hub (1930 to 1936, except LE Model)	28	"	"
304-40	Forked End Connecting Rod (1940 and later 61", 74" & 80" Twins)	36	.344"	.1875"
305-15	Single End Connecting Rod (1915 to 1939 - 61", 74" & 80" Twins)	12	.726"	.250"
"	Connecting Rod (30.50" Single)	12	"	"
"	Clutch Sprocket (1921 to 1936 - 61", 74" & 80" Twins except 61" OHV)	12	"	"
305-40	Single End Connecting Rod (1940 and later 61", 74" & 80" Twins)	18	.694"	.1875"
305-29	Single End Connecting Rod (1929 and later 45" Twins)	12	.550"	.250"
"	Right Crankcase (1937 and later 45" Twins)	12	"	"
306-26	Right Crankcase (1936 - 61"; 1937 and later 61", 74" & 80" Twins)	12	.600"	"
"	Connecting Rod (21" Single)	12	"	"
"	Left Crankcase (21" & 30.50" Single)	12	"	"

<u>Part No.</u>	<u>Where Used</u>	<u>No. Used</u>	<u>Length</u>	<u>Std. Dia.</u>
2289-17	Forked End Connecting Rod (1929 and later 45" Twins)	24	.270"	.250"
"	Clutch Sprocket (1926 to 1934 Singles and 45" Twins)	16	"	"
"	Countershaft Gear - Standard Transmission (1931 and earlier 61" & 74" Twins)	24	"	"
"	Main Drive Gear (1924 and earlier 61" & 74" Twins)	20	"	"
2289-25	Left Crankcase (1930 and later 61", 74" & 80" Twins)	24	.490"	"
"	Rear Wheel Hub (1923 to 1929 - 61" & 74" Twins)	32	"	"
"	Main Drive Gear (1925 to 1936 - 61", 74" & 80" Twins, except 61" OHV)	20	"	"
"	Clutch Gear (1934 and earlier, 45" and Single standard transmission)	16	"	"
"	Mainshaft (1934 and earlier, 45" and Single standard transmission)	12	"	"
"	Interchangeable Wheel Hub (1930 to 1936 - 74" and 80" Twins)	28	"	"
"	Countershaft Gear - right side - (1931 Reverse, 1932 to 1936 Reverse and Standard Transmission - 74" & 80" Twins)	12	"	"
"	Servi-Car Axle Outer Ends (1932 and later)	24	"	"
"	Wheel Hubs (1935 and later 45" Rear Wheel and 1941 Servi-Car front wheel, 1936 - 61", 1937 and later 61", 74" & 80" Twins - both wheels, "LE" Model Side-car Wheel)	26	"	"
2306-32	Countershaft Gear - left side - (1931 - 74" reverse, 1932 to 1936 - 74" standard and reverse transmission)	21	5/8"	.152"
"	Clutch Gear - left side - (1933 and 1934 - 45" Twin and Single Reverse, 1935 to 1940 - 45" Standard and Reverse transmission)	31	"	"
"	Mainshaft - right side - (1933 and 1934 - 45" Twin and Single Reverse, 1935 and later 45" Standard and Reverse transmission)	21	"	"
"	Countershaft Gear - left side - (1933 and 1934 - 45" Twin and Single Reverse, 1935 and later 45" Standard and Reverse transmission)	19	"	"
2289-36	Countershaft Gear - (1936 - 61", 1937 and later 61", 74" & 80" Twins)	44	.615"	.125"
"	Main Drive Gear (1936 - 61", 1937 and later 61", & 80" Twins)	44	"	"
"	Clutch Gear (1941 - 45")	40	"	"
2289-39	Countershaft Gear - right side - (1939 and later 45")	24	3/4"	.114"
2289-36A	Countershaft Gear - (1936 - 74" & 80" - 4 speed)	78	39/64"	.0625"

When assembling needle rollers in outer race preparatory to final assembly, apply a small amount of grease to hold rollers in place. Assemble specified number of rollers and observe that the last roller goes all the way into place freely and without requiring any effort to force it. If it doesn't go into place freely, leave it out. This is sometimes necessary when fitting oversize rollers, because they not only take up radial clearance, but also take up circumferential clearance. Rollers must not be crowded.

GUIDE FOR QUICK IDENTIFICATION  
OF ROLLER RETAINERS

PART NO.	WHERE USED	NO. USED	A	B	C	D	E
301-15	Front and Rear Connecting Rod Lower End (1921 to 1936-Big Twin Models) Left Crankcase - (1929 & earlier 61" & 74") Front Brake Hub - (1930 to 1936 - Big Twin Models) Connecting Rod 30.50" Single Model Clutch Sprocket - (1921 to 1936 - Big Twin Models, except 61" OHV)	4 2 2 2 2	1-29/64"	.434"	.370"	12	.260"
301-36	Front and Rear Connecting Rod Lower End - (1936 - 61", 1937 to 1939 - Big Twin Models)	4	1-37/64"	.434"	.370"	14	.260"
301-29	Front and Rear Connecting Rod Lower End - (1929 and later 45" Model)	4	1-29/64"	.341"	.282"	12	.260"
301-40	Front and Rear Connecting Rod Lower End - (1940 and later Big Twin models)	4	1-19/32"	.434"	.354"	18	.1935"
301-26	Connecting Rod (21" Single Model) Left Crankcase (21" & 30.50" Single Models)	2 2	1-21/64"	.370"	.309"	12	.260"
415-36	Right Crankcase - (1936 - 61", 1937 and later Big Twin models.)	2	1-29/64"	.370"	.321"	12	.260"
415-37	Right Crankcase - (1937 and later 45" Model)	2	1-21/64"	.341"	.282"	12	.260"
417-29	Left Crankcase - (1929 and later 45" Model)	2	1-21/64"	.444"	.377"	12	.260"

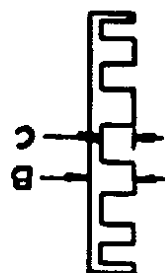

D - No. OF HOLES  
E - HOLE SIZE

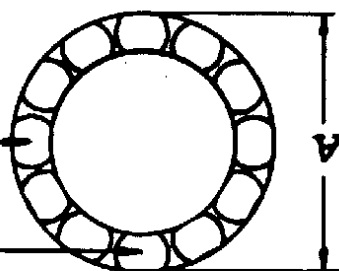

417-30	Left Crankcase - (1930 and later Big Twin Models) - - - - - Servo-Car Axle Outer Ends - (1932 and later) - - - - - Wheel hub - 1935 and later 45 model rear wheel; 1941 and later Servo-Car front wheel; 1937 and later Big Twin models, also 1936 OHV model front and rear wheel; "LE" model sidecar wheel - - - - -	1-29/64"	.581"	.502"	12	.260"
3993-23	Rear Wheel Hub - (1923 to 1929 - Big Twin Models) - - - - - Clutch Gear - (1934 and earlier Single & 45" Models) - - - - -	1-53/64"	.581"	.502"	16	.260"
2286-25	Main Drive Gear - (1925 to 1936 Big Twin Models, except 61" OHV) - - - - -	2.580"	.612"	.502"	20	.260"
2538-26	Clutch Sprocket - (1926 to 1934 Single and 45" Models) - - - - -	1-53/64"	.341"	.292"	16	.260"
2291-26	Transmission Mainshaft (1929 to 1934 Single and 45" Models) - - - - - Transmission Countershaft Gear - right side (1932 to 1936 Rev. & 3 speed Big Twin Models except 61" OHV)	1-21/64"	.303"	.252"	12	.260"
3922-30	Wheel Hub - (1930 to 1936 Big Twin Models except 61" OHV) - - - - -	1-37/64"	.581"	.502"	14	.260"
6171-30	Sidecar Brake Shell Hub - (1930 to 1936 Big Twin Models) - - - - -	1-45/64"	.434"	.377"	14	.260"
3967-35	Wheel Hub - 1935 and later 45 model rear wheel; 1941 and later Servo-Car front wheel; 1937 and later Big Twin models, also 1936 OHV model front and rear wheel; "LE" model sidecar wheel - - - - -	1-45/64"	.573"	.502"	14	.260"

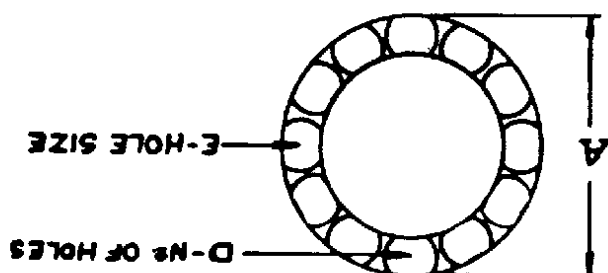
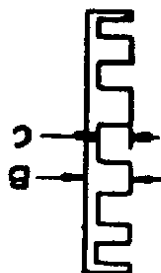



## FUEL SYSTEM

### CARBURETOR

The carburetor is a plain tube carburetor containing a venturi, and a discharge nozzle through which fuel is drawn into the air stream passing through the venturi. The quantity of fuel is metered by two jets or openings, one for low and one for high speed, before entering the nozzle.

Needle valves in the low and high speed passages allow the carburetor to be adjusted for the slightly varying and individual needs of the engine. Once a carburetor is adjusted, it requires little if any attention. At most, two "clicks" or notches richer or leaner on the needles are all that should be necessary to correct air-fuel mixture for changes in weather conditions. All carburetor final adjustments should be made with the engine at full operating temperature.

### ADJUSTING CARBURETOR

Before attempting to correct faulty engine performance through carburetor adjustment, check over "Locating Operating Troubles", Section 1C, particularly points 4, 5, 11, 12, 18, 19, 20, 35 and 36. In addition, be sure air cleaner element is clean and check car-

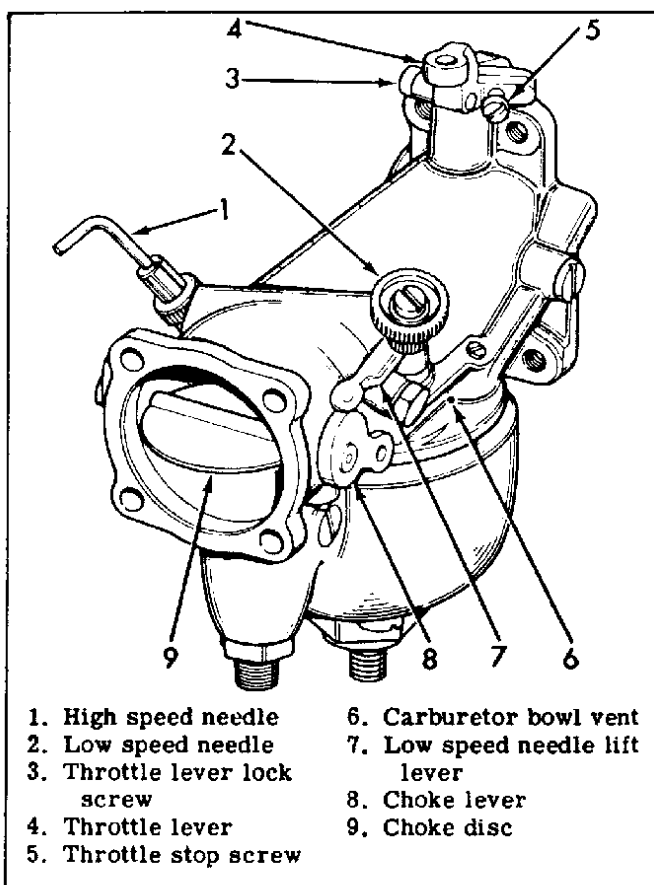

Figure 3F-1. Carburetor Controls and Adjustments

buretor and manifold connections to be sure they are tight.

Both high and low speed needles (1 and 2, Fig. 3F-1), are turned clockwise, or in, to make leaner mixture, and counterclockwise, or out, to make mixture richer. Both needles are held to whatever position they are set by a spring and ball plunger which drops into notches in the needle adjusting screw.

A carburetor may be adjusted as follows:

Turn both low and high-speed needles all the way in (clockwise). Back out the low speed needle five turns. Back out the high-speed needle two turns. With needles in these positions, the engine will start but the mixture will be too rich. Advance spark all the way or nearly all the way, whichever is best. Warm engine to full operating temperature and correct adjustment of both needles.

Adjust low speed first, with engine at operating temperature and idling. Turn needle in, one notch at a time, until mixture becomes so lean that the engine misses and acts starved. Back out the needle five to ten notches, or until engine hits regularly with spark advanced and throttle closed, or as nearly closed as it can be set and still have engine run at idling speed.

Adjust throttle lever stop screw (5, Fig. 3F-1) to make engine idle at desired speed with throttle fully closed. Turning screw clockwise makes engine idle faster. Never set idle adjustment to slowest possible speed. An extremely slow idle causes bearing wear, oil consumption and slow speed accelerating difficulties.

Make final readjustment on low speed needle. Try one notch at a time, first in and then out, to see if engine picks up speed or runs more smoothly. Starting and all around carburetion will be better with low speed adjustment set slightly rich rather than lean. If necessary, make further adjustment on idle stop screw to obtain desired idling engine speed. Retard spark completely. If carburetor is properly adjusted, engine will continue to run evenly and smoothly, though more slowly.

During high speed operation, fuel is metered by a fixed jet (35, Fig. 3F-2) which has no adjustment. However, the high speed needle may be used as "trimmer valve" to supplement the fuel flowing through the jet during extremely high speed operation (opened amount which achieves best results). It may be closed during operation at high altitudes to keep mixture from becoming too rich in the rarified air.

### DISASSEMBLING CARBURETOR (Fig. 3F-2)

Disconnect carburetor from motorcycle as follows:

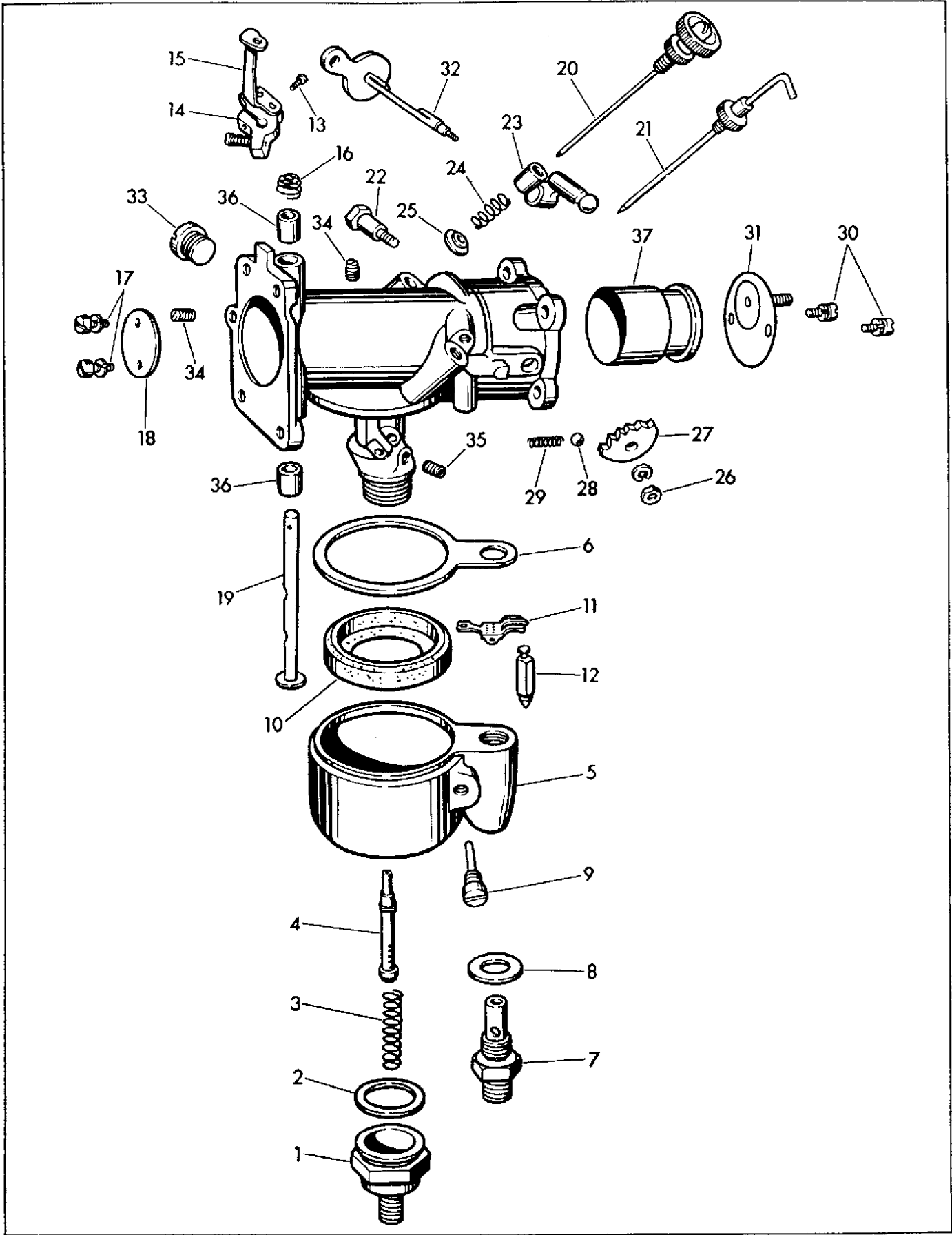

Figure 3F-2. Carburetor - Exploded View

## LEGEND FOR FIGURE 3F-2

1. Bowl lock nut	13. Throttle stop lock screw	26. Air intake shaft nut and washer
2. Lock nut gasket	14. Throttle lever	27. Air intake shaft stop
3. Main nozzle retainer spring	15. Throttle lever arm	28. Friction ball
4. Main nozzle	16. Throttle shaft spring	29. Friction spring
5. Bowl	17. Throttle shaft screw (2)	30. Air intake disc screw (2)
6. Bowl cover gasket	18. Throttle disc	31. Air intake disc
7. Float valve seat	19. Throttle shaft	32. Air intake shaft
8. Float valve seat gasket	20. Low speed needle valve	33. Idle hole body plug
9. Float lever pin	21. High speed needle valve	34. Idle passage plug screw (3)
10. Float	22. Needle valve lever screw	35. Fixed jet
11. Float lever	23. Needle valve lever	36. Throttle shaft bushing (2)
12. Float valve	24. Needle valve lever spring	37. Venturi (1-5/16")
	25. Lever spring collar	

Figure following name of part indicates quantity necessary for one complete assembly.

Remove air cleaner cover, element and back plate.

Disconnect fuel line with strainer at carburetor.

Disconnect throttle control wire.

Remove carburetor support from top center crank-case bolt.

Remove intake (choke) lever stud nut and washer. Twist intake lever off intake lever rod, and remove intake lever rod from carburetor.

Remove four carburetor fastening bolts and pull carburetor out to right.

Disassemble carburetor as follows:

Remove bowl lock nut (1), gasket (2), main nozzle retainer spring (3) and main nozzle (4). Remove bowl (5) and bowl cover gasket (6).

Remove float valve seat (7) and gasket (8). Turn out float lever pin (9) and slip float (10), float lever (11) and float valve (12) out of bowl.

Loosen throttle stop lock screw (13) and slip throttle lever (14) off throttle shaft with throttle lever arm (15) and throttle shaft spring (16).

Remove throttle shaft screws (17), slip throttle disc (18) out of slot in throttle shaft and pull out throttle shaft (19).

Remove low speed needle valve (20) and high speed needle valve (21).

Remove needle valve lever screw (22), needle valve lever (23), lever spring (24) and lever spring collar (25).

Remove air intake shaft nut and washer (26), air intake shaft stop (27), friction ball (28) and friction spring (29).

Remove air intake disc screws (30), air intake disc (31) and pull out air intake shaft (32).

Remove idle hole body plug (33) two idle passage plug screws (34) and carburetor fixed jet (35).

#### CLEANING, INSPECTION AND REPAIR (Fig. 3F-2)

Place all parts except gaskets and float in "Gunk Hydro-Seal" or other carbon and gum dissolving agent. Wash, and dry all parts with compressed air. Blow air through all carburetor barrel passages as shown in Fig. 3F-3. Never scrape carbon deposits from carburetor barrel or other parts with knife or other steel instrument.

Check throttle shaft fit in throttle shaft bushings (36). If excess play exists, use an appropriate size drift pin to remove old bushings. Press in replacement parts and line ream with a .250 in. drill.

Examine carburetor venturi (37). If it is extremely loose or pitted, slip out and replace.

Check float valve and float valve seat seal as follows:

Assemble parts 12 through 7 to carburetor bowl (5). Hold bowl upside down so float valve closes. Suck on bottom of float valve seat. If valve leaks, replace valve and seat.

If float is damaged or logged, replace with new part. Cut cement seal around float screw which secures float to float lever. Remove float screw and assemble new float to lever but leave screw loose. Position bowl so it is upright (the way it fits on carburetor barrel) with gasoline inlet on far side. Pull float toward you to the limit of the slot in float lever and about 1/16 in. to left of center line (see Fig. 3F-4). This provides clearance in float bowl. Tighten float screw and cement float screw to float with any cement that is impervious to gasoline, or thick shellac.

Check float lever as follows:

Turn assembled float bowl upside down. Measure distance from lip of float bowl to top of float directly opposite float lever. This distance should be exactly 1/4 in. When adjusting carburetor float, do not bend float lever while installed in bowl. Adjusting in this manner bends and spreads fingers between which

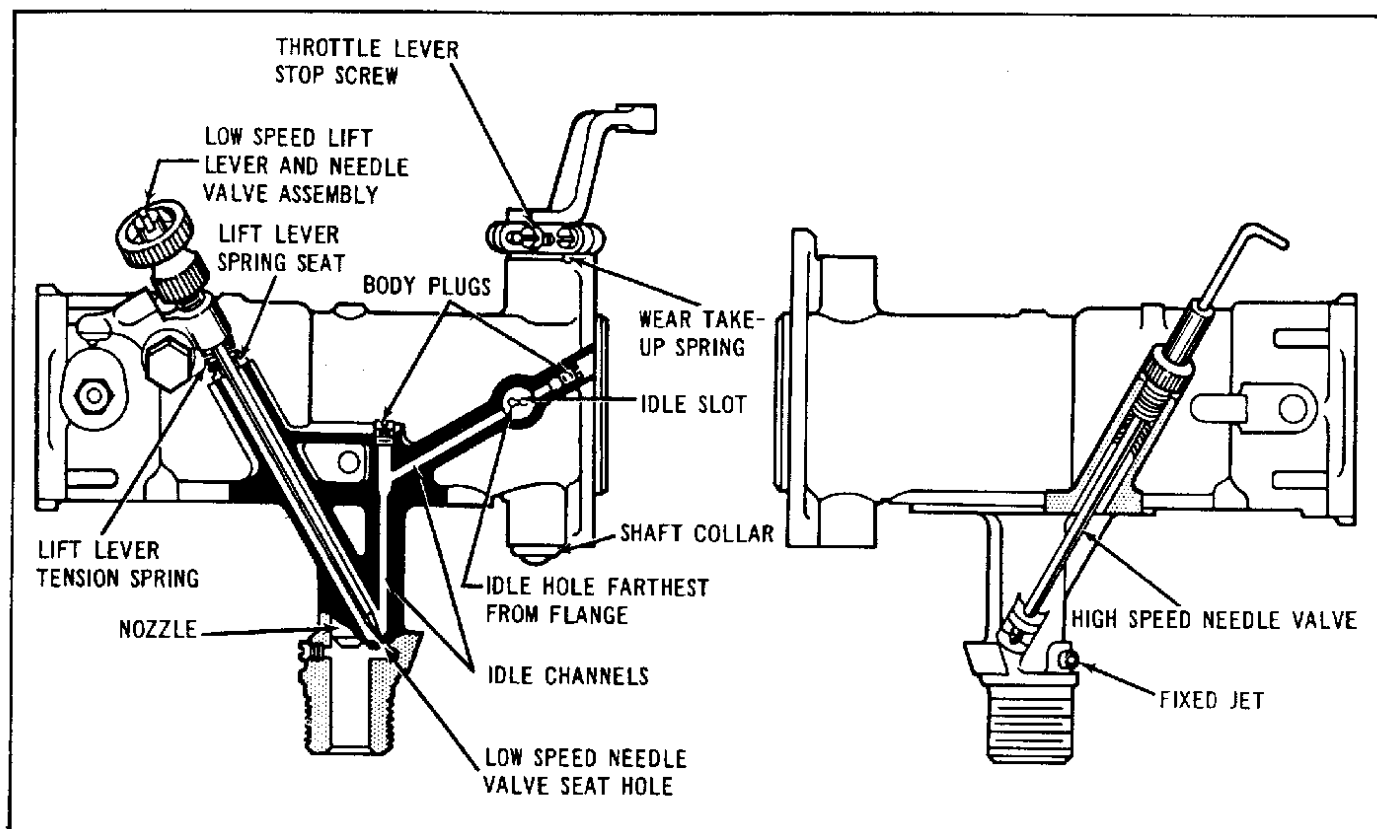

Figure 3F-3. Carburetor Passages and Needle Seats

head of float needle fits and develops lash or lost motion between float and needle. Float and lever assembly should be removed from bowl, and lever then bent as required.

Check needle head fit in float lever. It should be a free fit to about .003 in. clearance. To check clearance with float assembled, hold needle against seat with small screwdriver without restricting float lever. Move float up and down and observe free play between needle head and float lever (see Fig 3F-4).

#### ASSEMBLING CARBURETOR

Assemble carburetor in reverse order of disassembly. Pay particular attention to the following points.

Install venturi with choke end (small end) facing air intake opening.

Install throttle shaft from bottom of carburetor so counterbored screwhead notches are facing left side of carburetor when viewing carburetor from throttle shaft end. Notice that an edge of throttle disc has a flat on each side. Pass this edge of disc through throttle shaft, close throttle and insert throttle shaft screws (17) but do not tighten. Shift disc slightly until it seats all the way around carburetor throat. Tighten screws. Work disc several times. If there is any bind, loosen screws and reposition disc.

Position both throttle disc and throttle lever in wide open position before tightening throttle stop lock screw.

Throttle lever and shaft should open and close with just a slight drag. If too loose, loosen stop lock screw and compress parts on throttle shaft with fingers while tightening.

Install only replacement throttle disc containing same identification number on face. With disc correctly installed and closed, the number will be on right half of disc when viewed through manifold end of carburetor.

After assembly, adjust carburetor as described in "Adjusting Carburetor," page 3F-1.

#### AIR CLEANER

The air cleaner consists of a back plate, filter element and cover, arranged so all air drawn into carburetor passes through the filter. A mesh element traps all air borne dust to keep it from entering carburetor and engine.

**METAL MESH TYPE FILTER ELEMENT:** In normal service on hard surfaced roads, remove air cleaner mesh, wash in gasoline, and saturate with engine oil at least every 1,000 miles, or oftener under dusty service conditions. In extremely dusty service, clean and oil filter mesh every 100 miles or at least once a day.

**DRY CORRUGATED TYPE FILTER ELEMENT:** In normal service on hard surfaced roads, remove air cleaner cartridge every 1,000 miles, and shake cartridge by tapping lightly to remove loose dirt. If surfaces of element are oily or sooted, wash in gaso-

line. In extremely dusty service, both cleaning and cartridge replacement should be done more often.

### FUEL STRAINER

The fuel strainer, located underneath the carburetor float bowl, contains a fine mesh screen through which the fuel is forced to pass, trapping bits of dirt and any water that find their way into the fuel system. The unit should be cleaned and flushed at 2,000 mile intervals unless more frequent cleaning is indicated by irregular carburetion.

To clean the strainer, turn off fuel supply, turn off lower knurled cap and clean strainer. Washers need not be replaced unless they are faulty. The cap is replaced fingertight.

### FUEL TANKS

The fuel tanks are of welded steel construction. Fuel supply is shut off when plunger for reserve supply valve, located just ahead of the left tank filler cap, is turned down fingertight against its seat. The plunger is unscrewed (but not lifted) to use main fuel supply. The plunger is lifted to use reserve supply.

Fuel tanks are treated to resist rusting. However, prolonged operation with nearly empty tanks will increase condensation formation and hasten rusting. Moisture formation and damage may be avoided by using only "good grade" anti-knock, ethyl fuels with moisture absorbing additives. When motorcycle stands unoperated for any reasonably lengthy period, tanks should be drained and the tank interiors bathed with an oil-fuel mixture of equal proportions, and

then drained. The fuel will evaporate leaving a protective oil film on tank walls.

### REPAIRING LEAKING TANKS

Tank leaks may be gas welded or soldered. However, only firms or persons qualified to make such repairs should be entrusted with the operation. If ALL traces of fuel are not removed, an open flame repair may result in a tank explosion. Extreme caution in all tank repair is recommended.

### ALIGNING FUEL SHUT-OFF VALVE FITTINGS

When a left tank has been repaired the fuel shut-off valve should be realigned using Gas Shut-Off Valve Tool, Part No. 96365-42. The tool aligns top and bottom holes and correctly spaces them so the fuel shut-off valve operates without binding.

The tool consists of four parts: 1. Aligning Bar; 2. T-Handle; 3. Spacing Handle; 4. Stop Sleeve.

Use the tool as follows:

Remove left tank from motorcycle and disassemble all fuel fittings. Shift spacing handle in aligning bar so larger portion marked "aligning" is through hole. Turn aligning bar into bottom hole in tank and bend bottom of tank as needed to make end of bar line up with top hole in tank. Insert T-handle end fitting through top of tank and turn in part way.

Back out aligning bar until spacing handle may be shifted to portion marked "spacing." Turn aligning bar and spacing handle into each other until they are tight. Strike T-handle several sharp blows with hammer to square to tank fitting.

Remove tool and assemble valve rod and tank fittings.

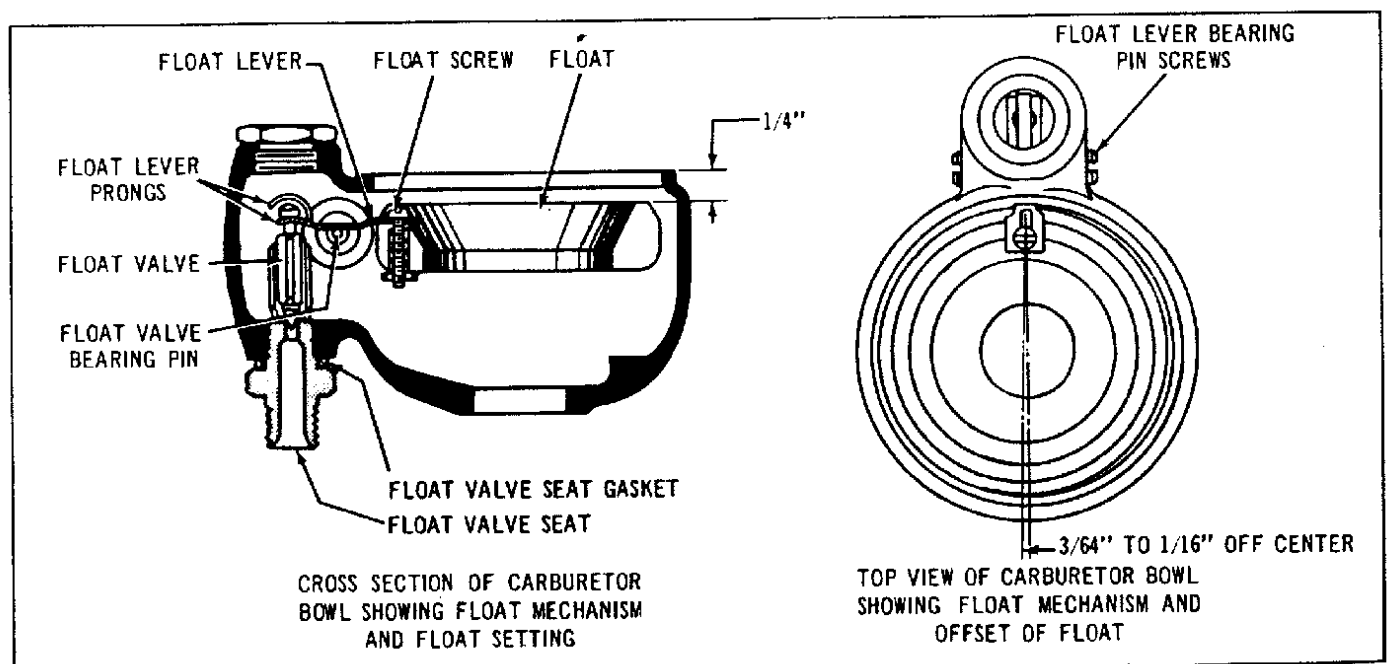

Figure 3F-4. Adjusting Bowl Float and Needle

# SHOP DATA:

## SERVICE NOTES FOR ALL MODEL "M" LINKERT CARBURETORS ON HARLEY-DAVIDSON MOTORCYCLES

These notes apply to carburetors which have been in service for some time and have become dirty, full of "crust" in the throttle barrel and are found to be difficult to get adjusted properly. Usually the effect of excessive dirt or "crust" formation in the carburetor throttle barrel, around the throttle disc and in the fuel mixture passageways is to cause the carburetor to have a lean spot off idle. This crust should be removed, particularly when a lean spot comes in at speeds off idle up to 30 M.P.H. with the low speed (idle) adjustment set properly for idling. The idle adjustment should not be set to the very lean side when checking this point, but to a point about five to ten notches rich from the setting where the engine dies from leanness.

### HOW TO REMOVE THE CRUST

1. Back off the throttle lever stop screw so that the throttle disc closes tightly. With a sharp pointed tool like a sharp pen knife or scribe, scratch a line deeply on the closed throttle disc and also on the throttle barrel so that the lines on the disc and on the barrel meet. These lines should "jibe up" again when you replace the disc. Remove the throttle lever, throttle disc and shaft, the idle hole body plug next to the idle holes in the throttle barrel, the body plugs in the carburetor flange and carburetor body idle channels and the low speed (idle) lift lever and needle valve assembly. Also remove the venturi and nozzle.
2. Scrape out the caking or crust in the throttle barrel with a scraper or knife, being sure not to cut into the metal.
3. Clean up the throttle disc by rubbing it on both sides on emery cloth on a flat plate and clean the edge of the disc all around, being careful not to round the corners or cut into the metal.
4. Clean out the idle holes in the throttle barrel next to the disc with the proper size drills of clean-up tool set described on last page of this bulletin. See following list for proper sizes for both holes for all models of carburetors.

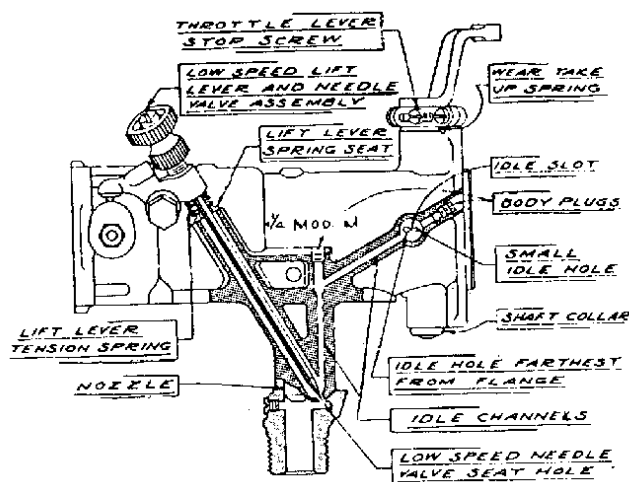

VIEW OF LINKERT MODEL "M" CARBURETOR  
SHOWING LOW SPEED NEEDLE VALVE,  
LIFT LEVER SPRING SEAT, LOW SPEED  
NEEDLE VALVE SEAT HOLE, IDLE HOLES  
AND SLOT, BODY PLUGS, AND IDLE CHANNELS

Model (Stamped in top of Carb. Body)	Carb. Size	Venturi Size	Small Idle Hole Nearest Manifold Flange (Drill Size)	Idle Hole Farthest From Manifold Flange (Drill Size)	Slot Width
M-4	1"	7/8"	#70	#54	.009"
M-11	1"	7/8"	#70	#54	.009"
M-16	1"	7/8"	#70	#54	.009"
M-2	1 1/4"	1-1/16"	#70	#54	.009"
M-5	1 1/4"	1-1/16"	#70	#55	.009"
M-5F	1 1/4"	1-1/16"	#70	#53	.009"
M-21	1 1/4"	1-1/16"	#70	#53	.009"
M-25	1 1/2"	1-5/16"	#72	#55	.009"
M-31	1 1/4"	1-1/16"	#70	#55	.0155"
M-31F	1 1/4"	1-1/16"	#70	#55	.009"
M-31F1	1 1/4"	1-1/8"	#70	#55	.009"
M-35	1 1/2"	1-1/8"	#72	#55	.009"
M-35F	1 1/2"	1-1/8"	#72	#55	.0155"
M-35S	1 1/2"	1-1/8"	#72	#55	.0155"
M-36	1 1/2"	1-1/8"	#72	#55	.0155"
M-41	1 1/4"	1-1/16"	#70	#55	.0155"
M-41F	1 1/4"	1-1/16"	#70	#55	.009"
M-41L	1 1/4"	1-1/8"	#70	#55	.009"
M-41LF	1 1/4"	1-1/8"	#70	#55	.009"
M-45	1 1/2"	1-5/16"	#72	#55	.009"
M-51	1 1/4"	1-1/16"	#70	#55	.020"
M-51F	1 1/4"	1-1/16"	#70	#55	.009"
M-51L	1 1/4"	1-1/8"	#70	#55	.009"
M-51LF	1 1/4"	1-1/8"	#70	#55	.009"
M-75	1 1/2"	1-5/16"	#72	#55	.009"
M-75F	1 1/2"	1-5/16"	#72	#55	.020"

(Model numbers followed by letter "F" or "F1" or "LF" apply only to carburetors used on California Highway Patrol motors.)

5. Clean out the slot of all 1" and 1 1/4" carburetors by inserting the tool with the .009" blade (this tool has plain handle) through the slot between the two idle holes. Use the tool with .0155" blade (this tool has two rings around its handle) to clean out the slot in M25, M35, M35F, and M35S 1 1/2" carburetors. Use the tool with .020" blade (this tool has 3 rings around its handle) to clean the slot in M75 and M75F 1 1/2" carburetors.
6. Clean out the idle channels with the #42 drill. When cleaning vertical idle channel do not completely bottom drill as doing so may damage the low speed needle seat.
7. Clean out the low speed (idle) needle valve seat hole with the proper drill size. All earlier 1 1/4" and 1 1/2" "M" carburetors are cleaned with the #53L drill. Later Model M-35, M-35S, M-75 and M-75F, 1 1/2" carburetors, have a smaller channel above the seat hole and for these use the #53L #2 drill which has a smaller handle, (this tool has two rings around its handle). All model 1" carburetors are cleaned with the #56L drill.
8. Blow out all channels and holes with compressed air and wash all parts in gasoline.
9. Re-assemble the parts, being sure the lift lever spring seat or washer is between the spring and carburetor body when assembling the low speed lift lever and needle

valve assembly back into place. This spring seat or washer limits the air bleed to the idle system and must be in place, otherwise carburetor cannot be adjusted for satisfactory engine idling.

Be sure the throttle disc is assembled in the barrel properly and closes off tight. Have the correct side of disc up or toward the flange and with the lines you scratched lining up with each other exactly. Push up the shaft collar on the throttle shaft firmly against the body before tightening the throttle disc screws. The throttle lever should be clamped to the shaft with the disc wide open and with the throttle lever wide-open stop against the body lug and with wear take-up spring between the throttle lever and bearing.

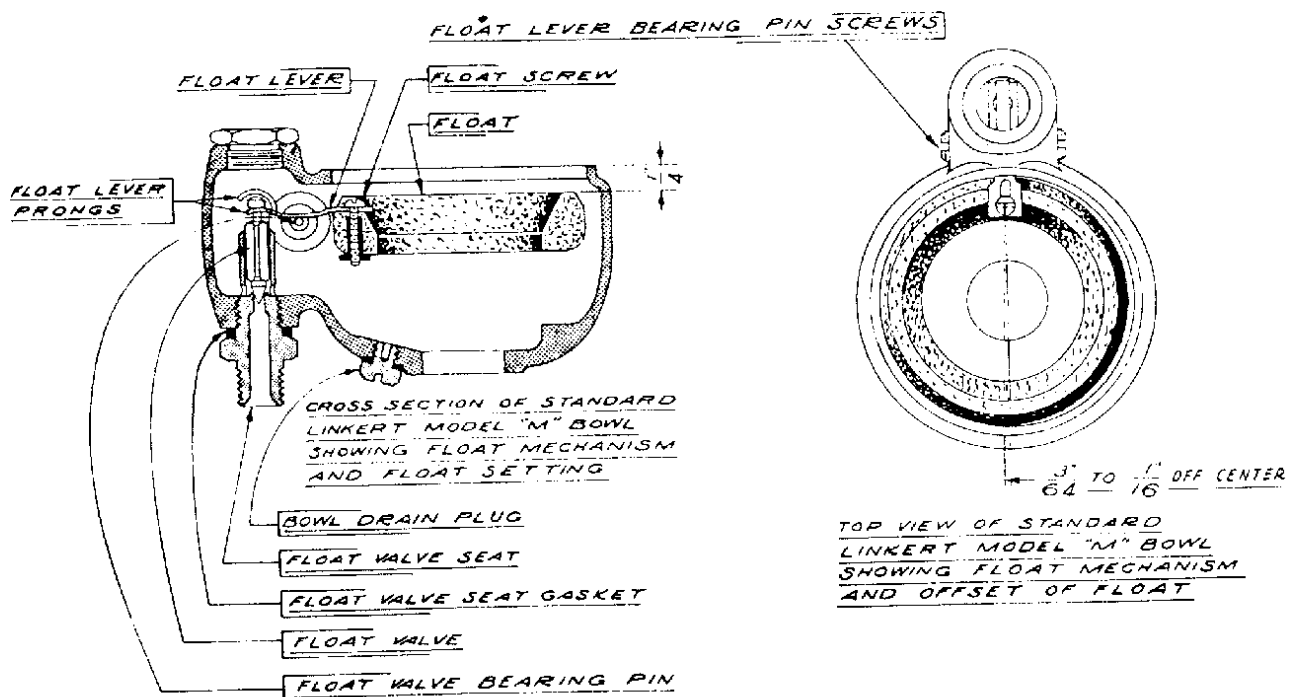

ATTENTION TO MODEL "M"  
LINKERT CARBURETOR BOWLS

10. If the carburetor bowl continually leaks or runs over, remove it from the carburetor body and first remove all dirt by cleaning it out with gasoline and compressed air. Hold the bowl up-side-down so that the float valve closes and suck on the bottom of the float valve seat. The valve and seat should hold this suction. If the valve and seat leak after repeated testing, replace with a new float valve and float valve seat.

11. If the float is damaged or "logged" replace with a new float. Remove the old float by cutting the seal around the float screw which fastens the float to the float lever. The seal can be cut with a pocket knife. Remove the float screw and assemble the new float to the lever. This should be done with the



float valve, float valve lever, float hinge pin and screws, float valve seat and gasket assembled in the bowl. Before tightening float screw securely, adjust as follows: Looking down on bowl with gasoline inlet side away from you, pull float toward you to the limit of slot in float lever and about  $1/16$ " to left of center line of bowl. This provides necessary body clearance. Tighten the float screw and cement the top of the float screw to the float with Dupont Household Cement or with a mixture of celluloid dissolved in acetone or with thick shellac. When the cement has dried thoroughly check the float height and adjust as explained in 12.

12. Check float level, and if necessary, re-set to  $1/4$ ". Measure directly opposite float lever with bowl held up-side-down (top of float to top of bowl). When re-adjusting Linkert carburetor float, do not attempt to do so by simply bending float lever upward in some manner, without disassembling from bowl. Re-adjusting in this manner bends and spreads the fingers between which the head of float needle fits, and thus develops lost motion between float and needle. Float and lever assembly should be removed from bowl, and lever then bent as required.

Before re-assembling, see that needle head is a good free fit between lever fingers with not more than approximately .003" play. This clearance can also be checked after the lever is assembled in bowl, by carefully placing a small screw driver or a small rod against the valve head in such a position that it will hold the valve firmly against the seat and yet not bind the lever. Moving the lever up and down will then show the amount of actual clearance between the valve head and fingers. If this clearance is excessive the float mechanism will not feed properly. After assembling note that float is approximately square with top of bowl.

13. The bowl drain plug now being used in the Model "M" carburetors can be removed for a quick flushing of the bowl. Before removing this plug turn off the gasoline at the tanks. Be sure to pull up this screw tight when replacing.

#### ADJUSTING CARBURETOR ON ENGINE

14. In adjusting the carburetor, set the low speed needle for smooth idling, and set throttle lever stop screw for desired idling speed.

Starting and all-around carburetion are better with low speed adjustment slightly rich rather than as lean as it can be made, and with throttle stop set for reasonably fast idling.

Average high speed needle adjustment for best engine performance is as follows: All Side by Side Valve engine carburetors - about  $1\frac{1}{2}$  turns open; all O.H.V. engine carburetors - Model M-25 about  $1\frac{1}{4}$  turns open; Models M-35 and M-36 about  $1-1/8$  turns open; Models M-45 and M-75 about  $1-3/4$  turns open. It is advisable to set high speed adjustment slightly rich rather than as lean as possible as a lean high speed mixture causes overheating.

#### CARBURETOR CLEAN-UP TOOLS

These tools are for hand cleaning only. Do not use in power or hand drill. A complete kit including 12 tools is covered by Part No. 12012-38. If you already have a set of clean-up tools that originally included ten tools, you will need only two extra tools to make your kit complete, part No. 12012-38L and 12012-38M. If you have an earlier kit that originally included only eight tools you will need to complete it the two extra tools just mentioned and also two additional tools, part No. 12012-38J and 12012-38K.

### CARBURETOR CONVERSION

The highly satisfactory performance of 1950 O.H.V. model carburetors (Manufacturer's Nos.: M-36; M-45; M-61; M-74) prompted investigating the possibilities of converting, at reasonable cost, earlier carburetor models to give them the same calibration and performance characteristics as 1950 O.H.V. carburetors. It has been found that two carburetor models can be converted. Consideration was first given to furnishing dealers a conversion kit enabling converting carburetors in the field, but this was found impracticable because of the extent of conversion required. Conversion must be made by the carburetor manufacturer.

The carburetor models that can be converted are the M-36 and M-45 (manufacturer's number stamped on top of carburetor body). Carburetors with other manufacturer's numbers cannot be converted.

If you wish to have carburetors converted under this conversion program, send them to Harley-Davidson Motor Co. on an instruction sheet separate from other parts that may be returned in the same shipment. In other words, applying to a mixed shipment, list carburetors for conversion on one instruction sheet and other parts in the shipment on a separate instruction sheet.

The charge per carburetor for conversion is \$5.00 net, plus tax. The M-36 carburetors you send back for conversion will be returned to you <sup>M-36</sup><sub>A</sub> or M-61 carburetors (Harley-Davidson part number 27142-50). Applying to the M-45 carburetor, the carburetor returned to you will be <sup>M-45</sup><sub>A</sub> or M-74 (Harley-Davidson part number 27143-50). Any of these numbers on carburetors returned to you indicate 1950 type carburetor. <sup>M-36</sup><sub>A</sub> and M-61 carburetors have 1-1/8" venturi. <sup>M-45</sup><sub>A</sub> and M-74 carburetors have 1-5/16" venturi. An M-36 carburetor cannot be converted to an <sup>M-45</sup><sub>A</sub> or an M-45 to an <sup>M-36</sup><sub>A</sub>. The <sup>M-36</sup><sub>A</sub> carburetor applies satisfactorily to either a 61 or 74 O.H.V. engine. The <sup>M-45</sup><sub>A</sub> is also considered an interchangeable carburetor, but it functions best on the 74 O.H.V.

Carburetors returned for conversion must be complete with all fittings and they must not be mutilated or altered in any manner. Carburetors incomplete, "beaten-up" beyond normal wear and tear, or carburetors with one or more body holes changed in size are not acceptable for conversion. Carburetors with paint removed as a result of cleaning in carburetor cleaning chemical are acceptable if not otherwise defaced or altered.

The manufacturers numbers of carburetors not acceptable for conversion are: M-35; M-35T; M-35TP; M-25; M-75; and no carburetor model in the 1 1/4" group. Carburetors, if complete, other than M-36 and M-45, are acceptable for exchange on the basis of our

**NOTE! Conversions from Harley factory no longer available**

long established exchange plan outlined on page 36 of latest accessory catalog. This exchange permits you to select any desired carburetor model for the one returned.

Applying to all 1950 O.H.V. carburetors (M-36; M-45; M-61; M-74) with fixed jet and limited further high speed adjustment, the setting of high speed needle for best performance is normally about  $1\frac{1}{4}$  turns open.

M-36 carburetors are further identified by a "Green paint dot" about  $1/4$ " in diameter on body near air intake end; M-45 carburetor has a "Red paint dot."

Don't expect either a new 1950 carburetor or converted carburetor to perform well unless engine is tuned otherwise for good performance.

**NOTE!** Conversions from Harley factory no longer available

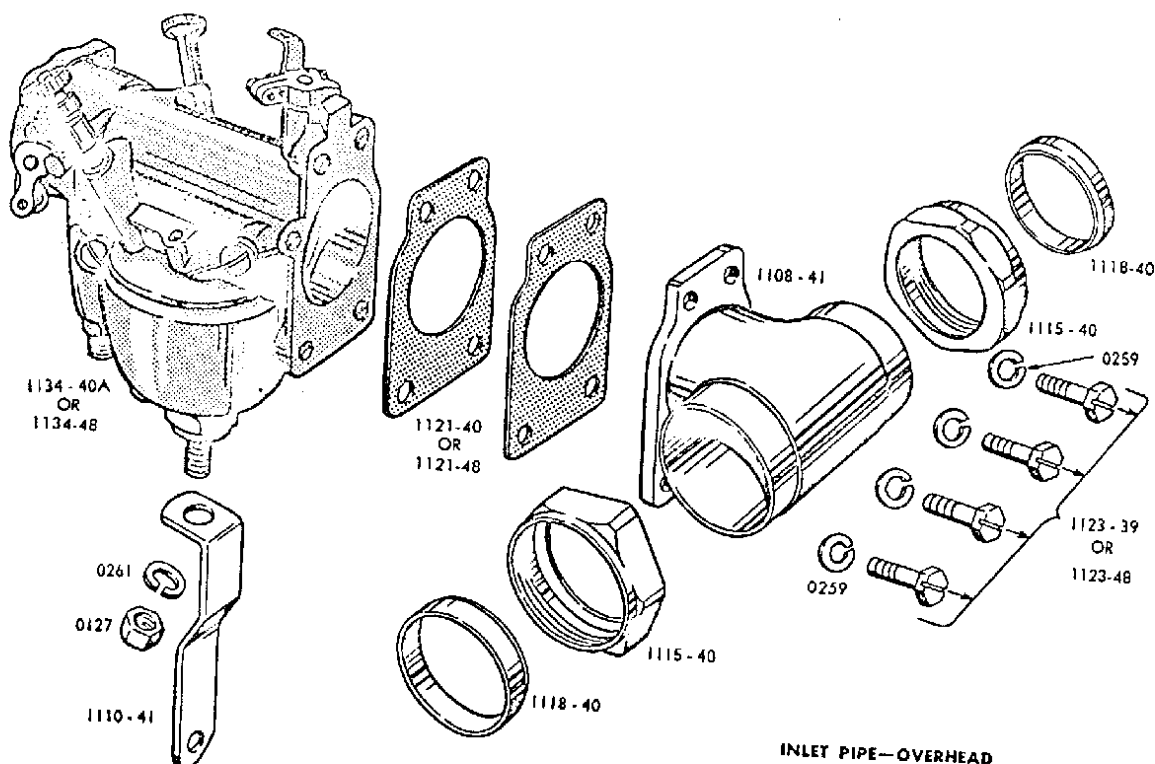

### How to install intake manifold (1948-54)

1. Loosen cylinder base nuts and cylinder head bolts.
2. Install intake manifold after close inspection to be certain that surface of the portion to join head is not bent, or out of round.
3. Use new brass packing gaskets.
4. Put manifold in place. Start large manifold flange nuts,

- aligning the manifold with flange, and tighten one nut snugly.
5. With a soft mallet, or screw driver, pry or tap the manifold to where it slips forward seating it to flange in head. Then with a pencil, mark manifold where it lines up with nut.
6. Then shove it back until it seats up against rear flange and mark with pencil.
7. Then move forward until

you have equal amount of space between the two penciled markings and the nut facings.

8. Tighten securely the two big nuts.
9. Tighten cylinder nuts.

To determine if connections leak, squirt light weight oil around one manifold flange (at main nut) at a time. If there is a leak, smoke will come out. Repeat with other flange.

CARBUREATORS

PART #	VENTURE SIZE	SMALL HOLE	LARGE HOLE	SLOT WIDTH	DISC ANGLE	MODEL	WHERE USED
1134-36	1 1/16	# 70	# 53	.009 "	13	M-5	1936 to 1939 E & EL (Superseded by M-55 during this period).
1134-36	1 1/16	# 72	# 55	.009 "	13	M-55	1936 to 1939 E & EL (Superseded by M-55 during this period).
27122-37	1 1/16	# 70	# 55	.009 "	13	M-51	1937 to 1948 74 & 80 SV except W & Servi-car (Superseded by M-52).
27122-37	1 1/16	# 70	# 55	.009 "	13	M-52	1949 to early 1951-45 except W & Servi-car (Superseded by M-54).
27122-37	1 1/16	# 70	# 55	.0155	13	M-54	Later 1951 & 1952-45 except K & Servi-car.
1134-37A	1 1/8	# 70	# 55	.009	13	M-51-L	1937 to 1941 UL and WLH.
27126-40	1/516	# 72	# 55	.0155	12	M-25	1940 E & EL 1941 F & FL (Superseded by M-75).
27126-40	1 5/16	# 72	# 55	.020	9	M-75	Optional for 1942 to 1948 F & FL.
27128-40	1 1/8	# 72	# 55	.0155	12	M-35 T & TP	1941 to 1948 E & EL Std for 1942 to 1948 F & FL
27120-30	7/8	# 70	# 54	.009	12	M-16	1937-48 W & Servi-car (Superseded by M-18).
27120-30	7/8	# 70	# 54	.009	12	M-18	1949 W & Servi-cars & late models.
27128-48	1 1/8	# 72	# 55	.0155	12	M-36	1949 E & EL, Early 1949 F & FL, Early 1950 E & EL (Superseded by M-61).
27128-48	1 1/8	# 72	# 55	.0155	12	M-61	Later 1950 E & EL, 1951 & later E & EL (Superseded by M-61B).
27128-48	1 1/8	# 72	# 55	.0155	12	M-61B	E & EL, FLK Superseded by M-74B.
27130-48	1 5/16	# 72	# 55	.020	9	M-45 & M-45A	Later 1949 F & FL; Early 1950 F & FL (Superseded by M-74).
27130-48	1 5/16	# 72	# 55	.020	9	M-74	Later 1950 F & FL; Early 1951 F & FL (Superseded by M-74B).
27130-48	1 5/16	# 72	# 55	.020	9	M-74B	Later 1951 to --- F & FL.
No Part #	1 1/8	# 72	# 55	.0155	12	M-36A	Was converted carb only for motorcycles in field
27146-52	19/32-1x	----	# 55	.020	8	M-53	K Model Superseded by M-52A.
27146-52A	1 5/16	----	# 55	.020	8	M-53A	K & KH Models.

Reformed float lever M-45A; M-74; M-74B  
 Float height (3/16) M-36A; M-61 (#18.0795); M-45A; M-74 (#17.076); M-74B (#19.082); M-54 (#11 1.25MM)  
 M-53; M-53A (#7-.0649); M-53A1 (#9-.070).  
 Idle Bleed M-53; M-53A (#53 reamer); M-53A1 (#50 reamer).  
 Loaded Float Screw M-36A; M-61; M-54

## GENERAL

### TRANSMISSION SPECIFICATIONS

#### CLUTCH (4B)

Type . . . . . Dry-multiple disc  
Capacity . . . . . 248 lb.-ft. torque  
Spring pressure (total) . . . . . 475 lbs.  
Roller bearing fit . . . . . .002 - .003 in. loose  
Spring adjustment . . . . . 31/32 in. from release to  
outer disc  
Disengagement . . . . . 5/32 in. movement of releasing  
disc from engaged position un-  
til release lever strikes cast-  
ing.

#### CHAIN

Type (primary) . . . . . 1/2 in. pitch, double  
Looseness . . . . . 3/8 - 1/2 in. slack

#### MAINSHAFT MAIN DRIVE GEAR (4D)

Roller bearing . . . . . .0005 - .002 in. loose  
Inner bearing . . . . . .002 - .003 in.  
Drive gear end play . . . . . .003 - .013 in.

#### MAINSHAFT (4D)

Low gear end bearing  
In housing . . . . . Snug fit  
On shaft . . . . . Light press  
Housing in case . . . . . Light press  
Third gear  
End play . . . . . .000 to .017 in.  
Bushing on shaft . . . . . .001 - .002 in. loose  
Bushing in gear . . . . . Press fit

#### COUNTERSHAFT (4D)

Drive gear end bearing . . . . . .0005 - .002 in. loose  
Low gear end bearing . . . . . .0005 - .002 in. loose  
Gear end play . . . . . .008 - .012 in.  
Second gear  
End play . . . . . .003 - .002 in.  
Bushing on shaft . . . . . .000 - .0015 in. loose  
Bushing in gear . . . . . .0005 - .0025 in. loose  
Low gear  
Bushing on shaft . . . . . .000 - .0015 in. loose  
Bushing in gear . . . . . .0005 - .0025 in. loose  
Shifter clutch clearance  
Low and second . . . . . .075 in.  
Third and high . . . . . .100 in.  
Sliding reverse gear . . . . . approx. .055 in.  
Gear backlash . . . . . .003 - .006 in.

#### SHIFTER CAM (4D)

End play . . . . . .0005 - .0065 in.

### FUNCTION OF TRANSMISSION

The transmission is comprised of four major as-semblies, the clutch, gear box, gear shifter and starter. Each is a part of power transmission from engine to rear wheel or a means of power con-trol.

#### CLUTCH

The clutch is made up of a drum or shell which is integral with the rear primary drive chain sprocket and which has inside a series of alternately positioned lined and unlined discs. The lined discs are doweled to the clutch hub which is keyed to the transmission shaft while the steel (unlined) discs are keyed to the clutch shell. When the clutch pressure plate is seated, a group of springs press the steel and lined discs together making a non-slipping connection be-tween the engine and transmission.

#### GEAR BOX

The gear box contains a series of gears on a main-shaft and countershaft which may be powered in a selection of ratios according to speed and load requirements.

#### GEAR SHIFTER

The gear shifter is a unit mounted to the gear box which shifts the gear box components into desired ratios by means of shifting forks that slide shifter clutches into and out of mesh along shafts.

#### STARTER

The starter provides a means of starting an engine by manual power. When pedal is moved in downward stroke, ratchet teeth in starter are engaged, trans-mitting the force through gear box and clutch and front chain to sprocket on engine crankshaft.

#### TRANSMISSION REPAIR PROCEDURE

When operating troubles develop in a transmission component, it is recommended procedure to first check following adjustments. If adjustments do not remedy the trouble, then proceed to disassembly and repair procedures.

1. Adjusting Clutch Control (4B)
2. Adjusting Clutch (4B)
3. Adjusting Shifting Linkage (4D)
4. Adjusting Foot Shifter Cover (4D)

# TRANSMISSION

If above adjustments do not correct trouble, disassemble and repair as described in repair sections. See "Locating Operating Troubles," for aids to diagnosing trouble. It is not necessary to remove transmission from chassis to disassemble clutch, starter, main drive gear oil seal or clutch release mechanism. However, extensive repairs are often easier and more quickly made if transmission unit is removed to bench as described in following section, "Stripping Motorcycle for Transmission Repair." The transmission can be removed as a unit (including clutch), or each component individually.

#### STRIPPING MOTORCYCLE FOR TRANSMISSION REPAIR

1. Remove clutch control rod from clutch release lever by loosening lock nut at pedal (foot control clutch) or at booster connection (hand control clutch) and turning rod out until length has been increased enough to slide flat portion out of slot in clutch release lever.
2. Remove left footboard and studs.
3. Remove outer chain guard.
4. If motorcycle is equipped with compensating sprocket, use Compensating Sprocket Shaft Nut Wrench, Part No. 94557-55, to remove compensating sprocket shaft nut. If not equipped with compensating sprocket, use Crank Pin Nut Wrench, Part No. 94545-26, to remove sprocket nut. It will be necessary to strike wrench handle with mallet to loosen nut. Free sprocket from shaft taper by striking flat surface near outer edge a light but sharp rap with soft metal mallet. Do not strike sprocket teeth or sprocket shaft threads. Sprocket and primary chain are then free to be removed.
5. Remove cotter pin, nut, flat washer and spring from each of the two inner chain guard rear mounting bolts. Bend back the ears of screw lock away from the three cap screws around the engine sprocket shaft that secure the front end of inner chain guard to engine crankcase, and remove cap screws and lock. Remove oil drain pipe from inner chain guard.
6. Disconnect shifter rod from transmission lever by removing nut and bolt.
7. Disconnect speedometer drive cable and housing from transmission. Disconnect neutral indicator switch wire clip.
8. Remove rear chain connecting link and chain.
9. Remove bolt which secures transmission to support bracket on right side of frame.
10. Remove two bolts and two cap screws which secure transmission mounting plate to chassis.
11. Remove complete transmission with mounting plate, clutch and inner chain guard from left side of chassis.

#### NOTE

It is not necessary to remove transmission from chassis to adjust or repair the clutch or starter mechanism.

## CLUTCH

### GENERAL

The clutch or clutch control mechanism needs attention when the clutch slips under load, or drags in released position. For causes of slipping clutch see "Locating Operating Troubles," Section 1C, items 93, 94 and 95. If clutch drags or fails to release, see items 96, 97, 98, 99 and 100. If clutch chatters when being engaged, see 101 and 102. Before disassembling clutch when repair is indicated, readjust gear shifter control and clutch spring tension. It is not necessary to remove transmission from chassis to adjust or repair clutch.

### ADJUSTING FOOT CLUTCH CONTROL (Fig. 4B-1)

With foot pedal (1) in fully disengaged position (heel down), the clutch lever (8) should strike the transmission case cover. Adjust length of the foot pedal rod (3) to just clear the foot pedal bearing cover (2) so the rod is not bent down by the bearing cover.

Remove the chain guard clutch cover (7), move the foot pedal (1) to a toe down or fully engaged position, loosen the lock nut (5) and readjust the push rod adjusting screw (4) with a screwdriver so that the end of the clutch lever rod (8) has about 1/8 in. free movement. Turn screw (4) right for less movement and left, for more.

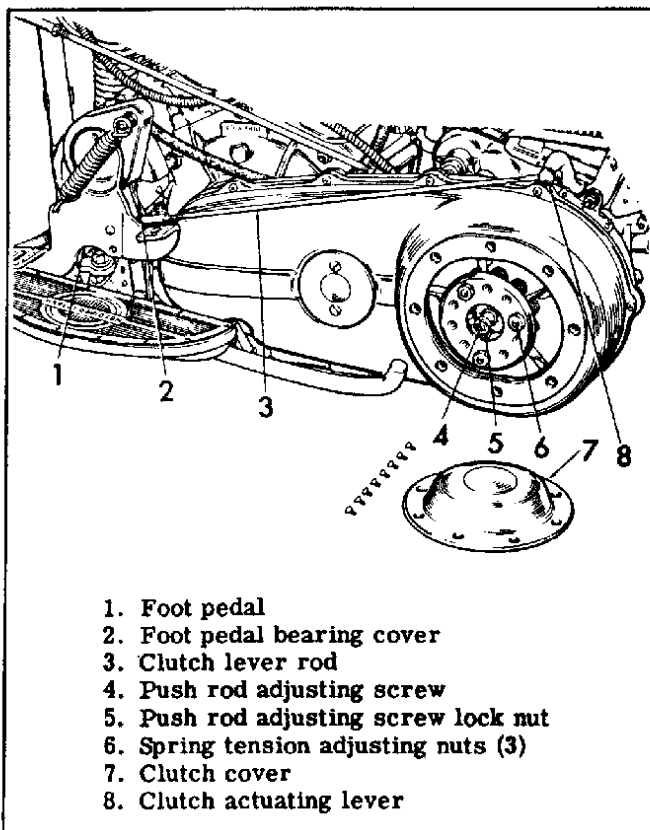

1. Foot pedal
2. Foot pedal bearing cover
3. Clutch lever rod
4. Push rod adjusting screw
5. Push rod adjusting screw lock nut
6. Spring tension adjusting nuts (3)
7. Clutch cover
8. Clutch actuating lever

Figure 4B-1. Adjusting Foot Clutch Control

### ADJUSTING HAND CLUTCH CONTROL (Fig. 4B-2)

Normally, the only attention the clutch hand control requires is occasional adjustment of control coil adjusting sleeve (1) and the clutch lever rod (5) to maintain the correct amount of free movement for hand lever on handlebar and clutch actuating lever.

If major readjustment is indicated by hand lever becoming hard to operate, clutch control booster bellcrank failing to return to forward position when hand lever is released, slipping clutch, or dragging clutch manifested by gear clash when shifting, the following adjustments should be made:

Loosen clutch lever rod lock nut (7) and unscrew clutch lever rod (5) far enough so clutch actuating lever (1, Fig. 4B-3) has about 1/2 in. free movement. Move end of actuating lever forward to a position where it becomes firm indicating that all slack in the actuating mechanism has been taken up. The distance from the foot shifter housing on transmission to the outer edge of chamfered slot in lever (1) should be 4-1/4 in. as shown in Fig. 4B-3. If necessary, readjust to obtain this measurement as follows:

Remove clutch cover (2, Fig. 4B-3), loosen push rod adjusting screw lock nut (4) and turn push rod adjusting screw (3) to the right to move lever to rear; to left to move lever forward. When correct position of lever has been attained, tighten lock nut and install clutch cover.

Refer to Fig. 4B-2. Loosen control coil adjusting sleeve lock nut (2) and turn in adjusting sleeve until clutch hand grip has an inch or more free play.

Loosen bell crank adjusting screw lock nut (4) and tighten bell crank adjusting screw (3) until bell crank (8) fails to go across top dead center, as shown, when moved back and forth by hand.

Loosen clutch booster spring tension upper adjusting nut (13) as far as it will go.

Turn out bell crank adjusting screw a little at a time until bell crank moves over top dead center and remains in that position when released. Move bell crank by hand, not with control hand lever. Bell crank should find locked position at about 1/8 in. over dead center. Tighten adjusting screw lock nut (4).

Adjust clutch lever rod (5) so clutch actuating lever has 1/16 in. free movement. Tighten clutch lever rod lock nut (7).

Turn adjusting sleeve (1) upward until end of clutch hand lever has 1/2 in. free movement before releasing pressure is applied to clutch. Tighten lock nut (2).



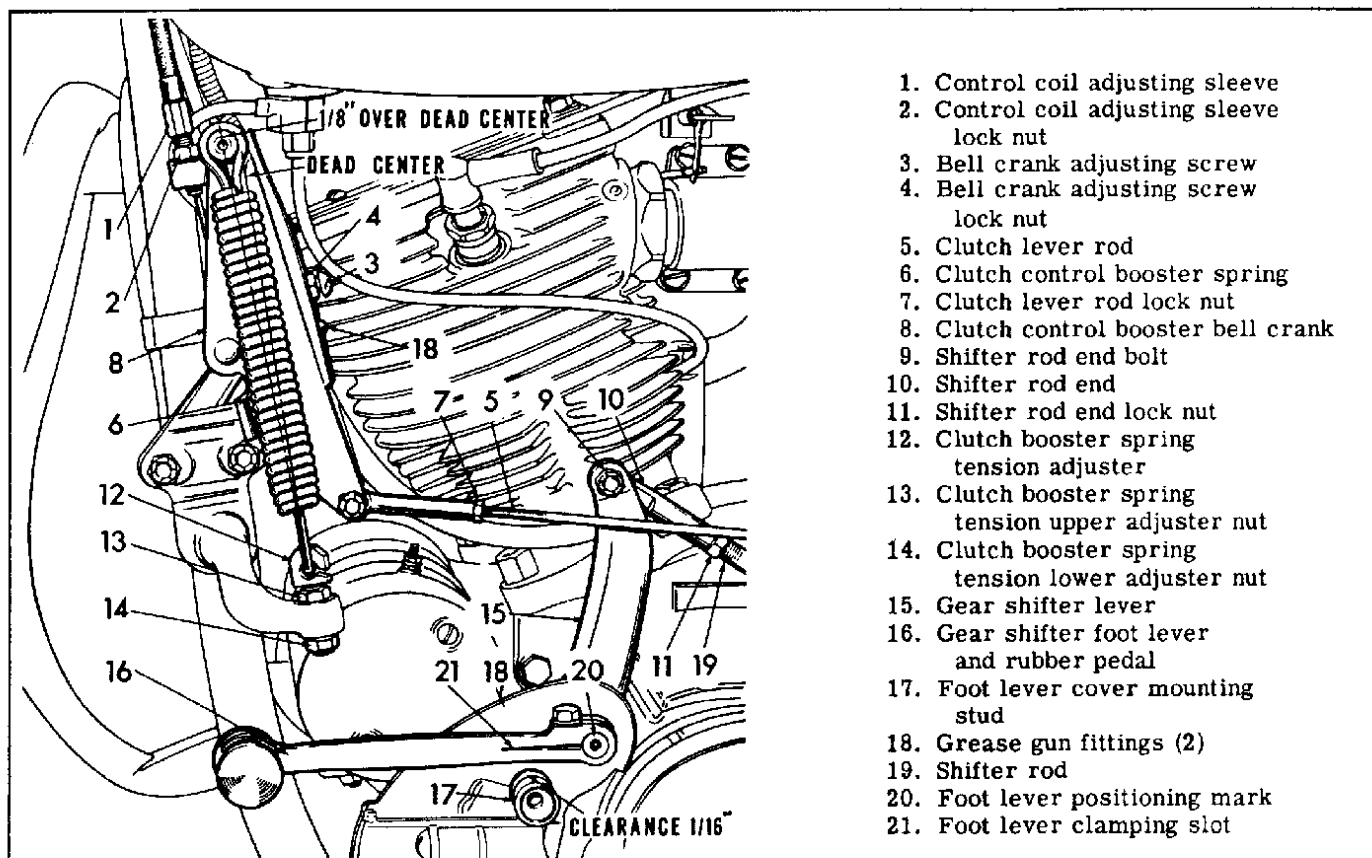

Figure 4B-2. Adjusting Hand Clutch Booster

Depress clutch hand lever fully. Tighten clutch booster spring tension lower adjusting nut (14) until hand lever remains depressed. Slowly loosen lower adjusting nut enough to allow hand lever to return to fully extended position. Tighten upper adjusting nut (13).

#### ADJUSTING CLUTCH

If the clutch slips after adjusting clutch controls, increase spring tension on the three clutch spring guide stud nuts (6, Fig. 4B-1). Tighten all three nuts one-half turn at a time until clutch holds. Test after each half turn by cranking the engine. Usually a clutch that holds without noticeable slipping when cranking the engine will hold under normal road conditions. Do not increase spring tension any more than is necessary to make clutch hold.

A new clutch is assembled so the distance from inner edge of spring collar (2, Fig. 4B-4) to the surface of the outer disc (9) is exactly  $31/32$  in. If springs are compressed so this distance is  $7/8$  in. or less, the clutch probably cannot be fully disengaged.

When clutch will not hold without tightening beyond this limit, disassemble the clutch for inspection of the clutch discs. Discs may be worn or oil soaked and in need of replacement or washing.

#### DISASSEMBLING CLUTCH (Fig. 4B-5)

Remove outer chain guard.

Remove push rod adjusting screw lock nut (1). Place a flat washer about  $1/8$  in. thick with  $1-3/4$  in. outside diameter and  $3/8$  in. hole over the adjusting screw (2). Replace lock nut and turn down until three spring tension adjusting nuts (3) are free. The nuts may then be removed and the spring collar-springs-outer disc assembly (4, 5 and 6) may be slipped off clutch hub dowels and studs as shown in Fig. 4B-4. Do not disassemble these parts unless necessary for spring, spring collar or outer disc replacement.

Remove spring disc (7). Remove three steel discs (8) and three lined friction discs (9).

Remove engine sprocket or compensating sprocket as described in "Stripping Motorcycle for Transmission Repair," page 4A-2, step 4.

Remove clutch shell (10) and primary chain from clutch hub.

Pry back ear on clutch hub nut lock washer. Remove clutch hub nut (11) using Clutch Hub Nut Wrench, Part No. 94645-41. Thread is left hand. Loosen nut by striking wrench handle several sharp blows with a mallet. Remove clutch hub nut lock washer (12) and strip push rod cork oil seal (13) off push rod.

Remove clutch hub (14) using Clutch Hub Puller, Part No. 95960-41. Turn tool center bolt back until puller plate may be slipped over clutch hub studs and against ends of clutch hub pins. Secure puller

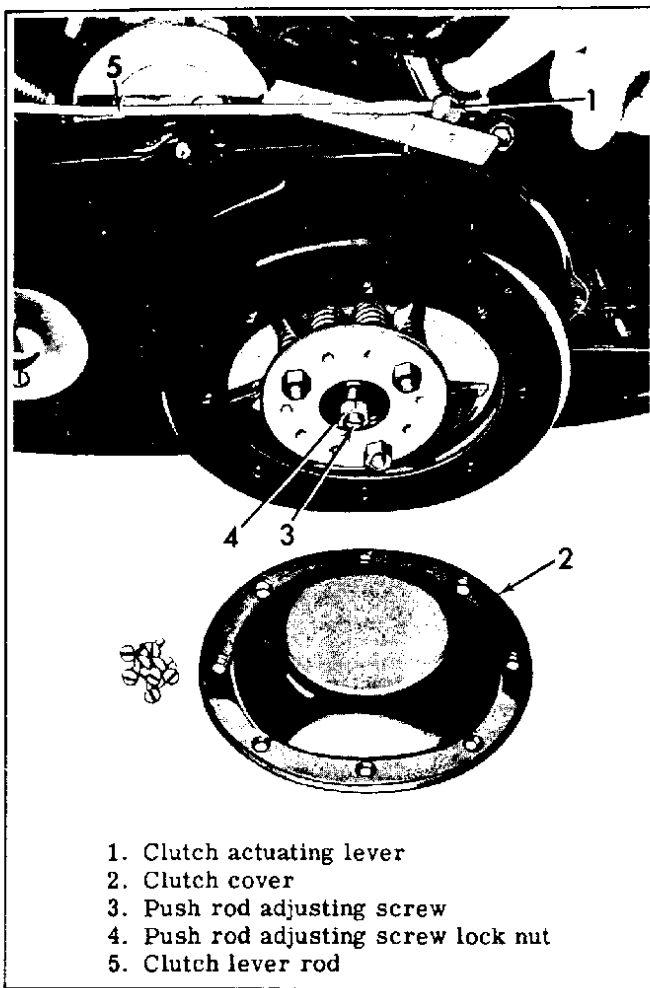

1. Clutch actuating lever
2. Clutch cover
3. Push rod adjusting screw
4. Push rod adjusting screw lock nut
5. Clutch lever rod

Figure 4B-3. Positioning Clutch Actuating Lever

plate with the three clutch spring guide stud nuts. Turn down tool center screw until clutch hub breaks free from gear box shaft taper. Remove clutch hub key (15).

**CLEANING AND INSPECTION**

Wash all parts except lined discs in cleaning solvent and blow dry with compressed air.

Examine lined plates for:

1. A glazed surface which may be recognized by a smooth, shiny and sometimes darkened appearance.
2. Worn or grooved surface.
3. Lining worn down to rivets.
4. Oil impregnated linings which will sometimes accompany glazing.
5. Cracked or chipped linings.

Glazed and oil soaked discs may sometimes be reconditioned by soaking in white gas for several hours, blowing dry with compressed air and roughing with medium coarse sandpaper. Grooved linings and linings worn down near the rivets must be replaced. Chipped or cracked linings must also be replaced. Badly glazed and burned linings are probably beyond reconditioning and should be replaced.

Steel discs that are grooved or warped should be replaced. Depress steel disc buffer balls with fingertip. If they do not snap back in place, spring is worn and buffer assembly must be replaced.

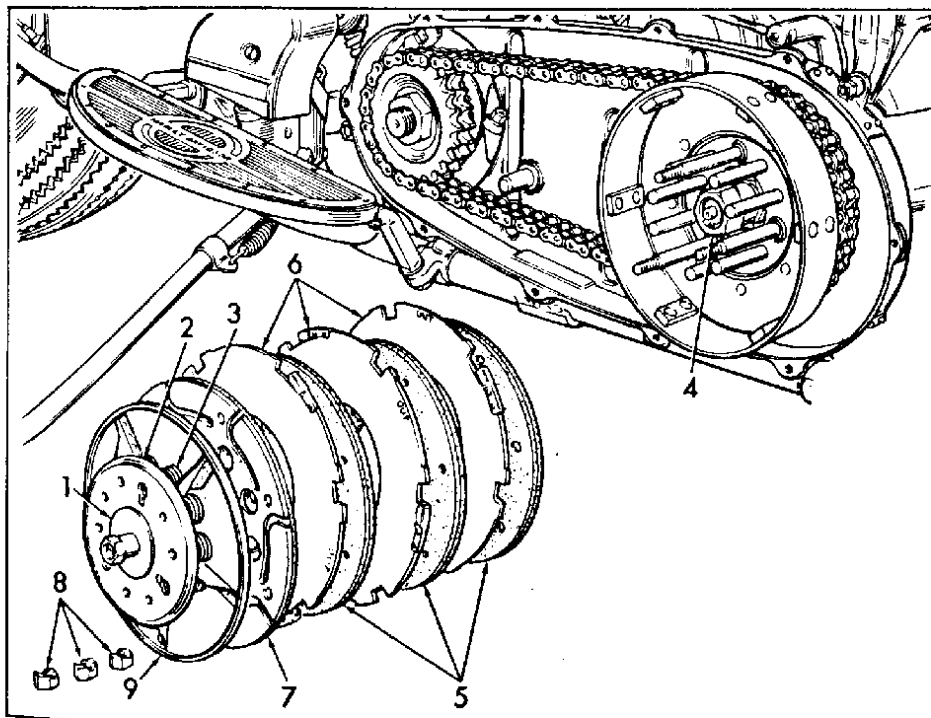

1. Flat washer
  2. Spring collar
  3. Springs
  4. Clutch hub nut
  5. Lined friction discs (3)
  6. Steel discs (3)
  7. Spring disc
  8. Spring tension adjusting nuts (3)
  9. Outer disc
- Figure following name of part indicates quantity necessary for one complete assembly.

Figure 4B-4. Removing Clutch

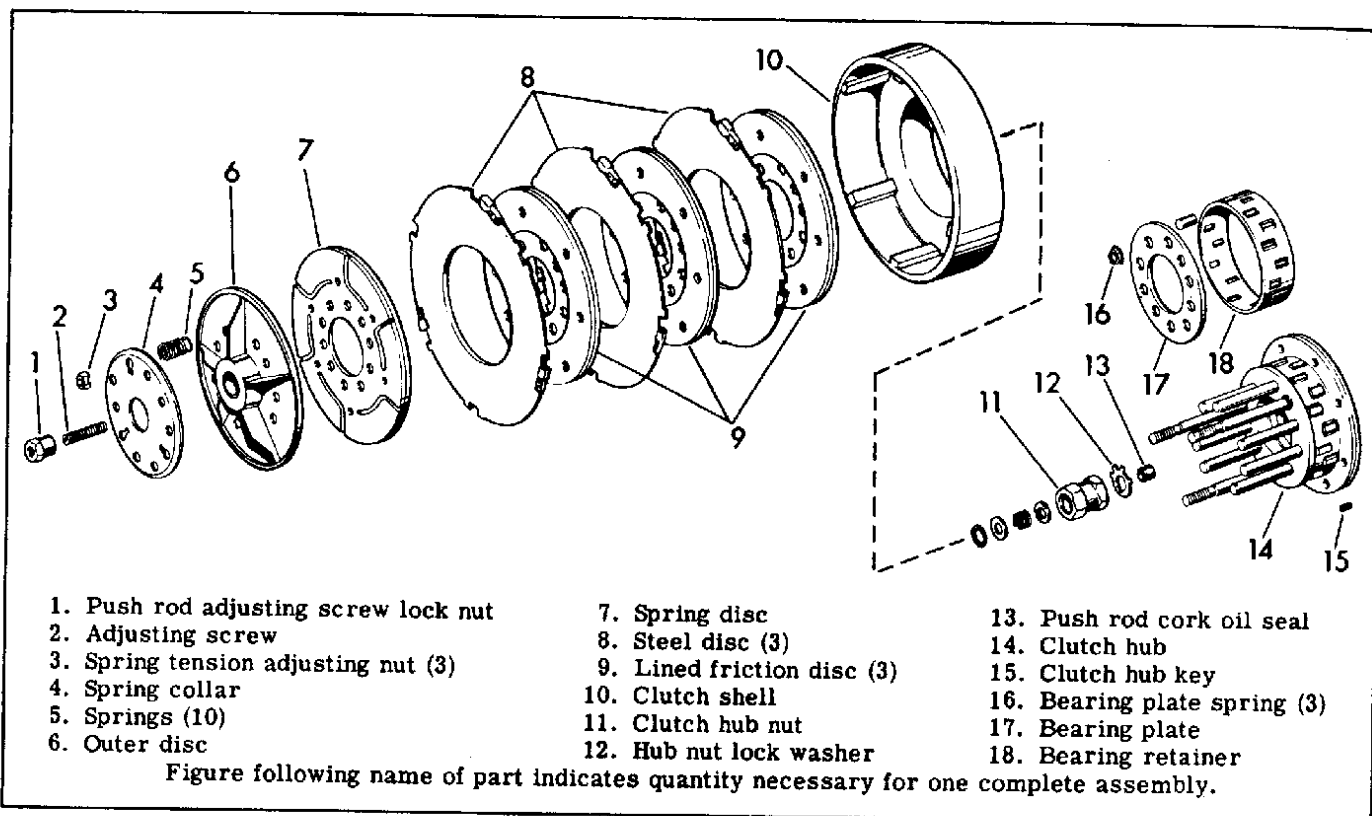

Figure 4B-5. Clutch Assembly - Exploded View

Check bearing race inside clutch shell. If it appears grooved or pitted, the shell should be replaced.

Revolve clutch hub roller bearing. If it sticks or feels rough, inner bearing race is probably pitted and should be replaced. Disassemble clutch hub as follows:

Remove three bearing plate springs (16), slip bearing plate (17) off hub pins and remove bearing retainer (18). If inner race thus exposed proves to be worn, replace hub.

Clutch springs occasionally set or become fatigued, especially when excessive heat has been produced by operating motorcycle with a slipping clutch. If this has been the case, or if clutch discs are in good condition but it was not possible to obtain a suitable clutch adjustment, check clutch spring free length. Also check spring compression using the Valve Spring Tester, Part No. 96797-47. Spring free length should be 1-31/64 in., and compression test should be from 43 to 52 pounds at 1-1/8 in. Replace springs not meeting compression specifications and those with a free length below specified figure, compression testing to near low tolerance range figure.

Check push rod oil seal spring located inside clutch hub nut with fingertip. If the spring returns both washers to position against shoulder or spring ring, parts are serviceable.

#### ASSEMBLING CLUTCH (Fig. 4B-5)

Assemble clutch in approximate order of disassembly.

If parts 1, 2, 4, 5 and 6, have been disassembled, pre-assemble them on clutch hub as follows: Place clutch releasing disc on hub. Position springs on pins and studs. Place pressure plate over springs. Note that stud holes are arranged so plate fits in only one position. Turn adjusting screw lock nut on adjusting screw until head is flush, then turn into clutch releasing disc with 1-3/4 in. washer under nut. Remove this pressure plate assembly from hub.

Place key in slot in mainshaft. Slip clutch hub onto shaft. Install new cork oil seal on clutch push rod. Position washer followed by hub nut. Tighten nut with the special wrench. Strike wrench handle several sharp blows with mallet. Bend over the ear on washer matching hub nut flat. Grease clutch shell bearing and install clutch shell.

Install lined and steel discs in clutch shell, staggering position of steel disc buffers in key slots in shell. Make sure steel discs are installed with side stamped "OUT" facing outward.

Install pressure plate assembly. Draw down adjusting nut until stud nuts may be started. Turn down stud nut until 1-3/4 in. washer is loose. Remove washer and replace adjusting nut.

Draw down stud nuts evenly until distance from back of pressure plate to front of clutch releasing disc is 31/32 in.

Make final adjustments to clutch as described in "Adjusting Clutch Foot Control," or "Adjusting Clutch Hand Control," and "Adjusting Clutch."

## STARTER

### DISASSEMBLING STARTER (Fig. 4C-1)

Remove starter assembly from gear box as follows:

Place oil drain pan under transmission. Remove starter cover nuts (1) and plain washers (2). If transmission is in chassis, remove clutch lever rod from left end of clutch release lever. Cover assembly with clutch release lever assembly is then free to be pulled off mounting studs. Clutch release bearing (3) will come off with cover. If starter cover binds, release bearing is binding on starter clutch. Pry bearing off starter clutch. Do not pry cover for it will damage bearing. With starter cover removed, push rod (4) is free to be pulled out of mainshaft.

Clamp crank (8) in vise, bend ear of lock washer (6) away from flat of starter crank nut (5) and remove nut and lock washer (6). Remove starter gear (7) using the Harley-Davidson All Purpose Claw Puller, Part No. 95635-46. If puller is not available, remove starter crank from vise, and drive starter crank out of starter gear with rawhide mallet. Be sure to hold starter crank and cover from swinging when shaft is free from gear.

With starter gear removed, crank (8) can be pulled out of cover. Thrust washer (9) is installed between starter crank spring (10) and cover (11) with chamfered side of washer facing spring.

Remove nut (12) and lock washer (13), and pull release lever (14) from end of clutch release lever shaft (15) using All Purpose Claw Puller.

Remove cotter pin (16) and plain washer (17) from lower end of release lever shaft, which can then be pulled out of cover, freeing release finger (18) and thrust washer (19).

### CLEANING, INSPECTION AND REPAIR (Fig. 4C-1)

Wash all parts in a grease solvent and blow dry.

Insert starter crankshaft in starter cover and check play. If play is appreciable, press out bushings (20) and install new parts. If transmission was leaking oil out starter crank, install new oil seal (21). Bushings are pressed in with outside ends just flush with bushing boss and outer surface of cover.

Bushings (22 and 23) rarely need replacement. However, check fit of release lever shaft and press out old bushings and install replacement parts if shake is considerable.

Check clutch push rod bearing for wear. Replace unit that grinds, feels rough or loose when rotated.

Check starter crank gear cam plate and gear pin to be sure they are in good condition, especially if starter crank bushings were replaced.

### ASSEMBLING STARTER (Fig. 4C-1)

Install release lever shaft (15) and release finger (18) in cover with thrust washer (19) located between finger and bushing (23), and plain washer (17) and cotter pin (16) on end of shaft.

Install starter crank spring (10) and thrust washer (9) on starter crank with chamfer side facing spring, and apply a film of light grease on oil seal (21) and on end of starter crank shaft before installing crank (8). Hold crank in vise and wind spring by turning cover clockwise. Install starter crank gear (7) so dowel pin holds crank in normal, upward position. Install lock washer (6) and nut (5) and tighten nut securely. Bend over one ear of lock washer against one flat of nut. Install gasket (24) over studs on case.

Before starter cover is installed, clutch release bearing (3) is inserted into cover, with slot in outer bearing race engaging clutch release finger (18). Insert push rod (4) small diameter end into clutch release bearing and place the other end into mainshaft. With push rod serving as pilot, move cover assembly into place. Groove in clutch release bearing inner race and ball plunger in starter clutch must align so they will be engaged when assembly is completed. Turn on and draw up all cover nuts and washers.

Refill unit with 1-1/2 pints of same grade oil used in engine.

### DISASSEMBLING STARTER CLUTCH (Fig. 4C-1)

Remove starter cover assembly as described in "Disassembling Starter," and proceed as follows:

Bend ear of lock washer away from flat of starter clutch nut (25) and remove nut and washer (26). Pull starter clutch (27) from mainshaft taper with Starter Clutch Puller, Part No. 95650-42. With starter clutch removed, starter clutch keys (28), starter mainshaft gear (29) and starter clutch spring (30) are free to be removed from mainshaft.

### CLEANING, INSPECTION AND REPAIR (Fig. 4C-1)

Wash all parts except gasket (24) in grease solvent and blow dry with compressed air.

Examine teeth on starter clutch and starter gear (29), ratchet teeth on mainshaft gear and starter clutch. Teeth should be sharp edged. If teeth are rounded or mushroomed and rider has experienced ratchet slip, replace worn parts. If starter clutch nut has previously been drawn down too tight, starter clutch may be cracked. If cracked, it is usually difficult to get the starter clutch out of clutch release bearing when disassembling starter cover.

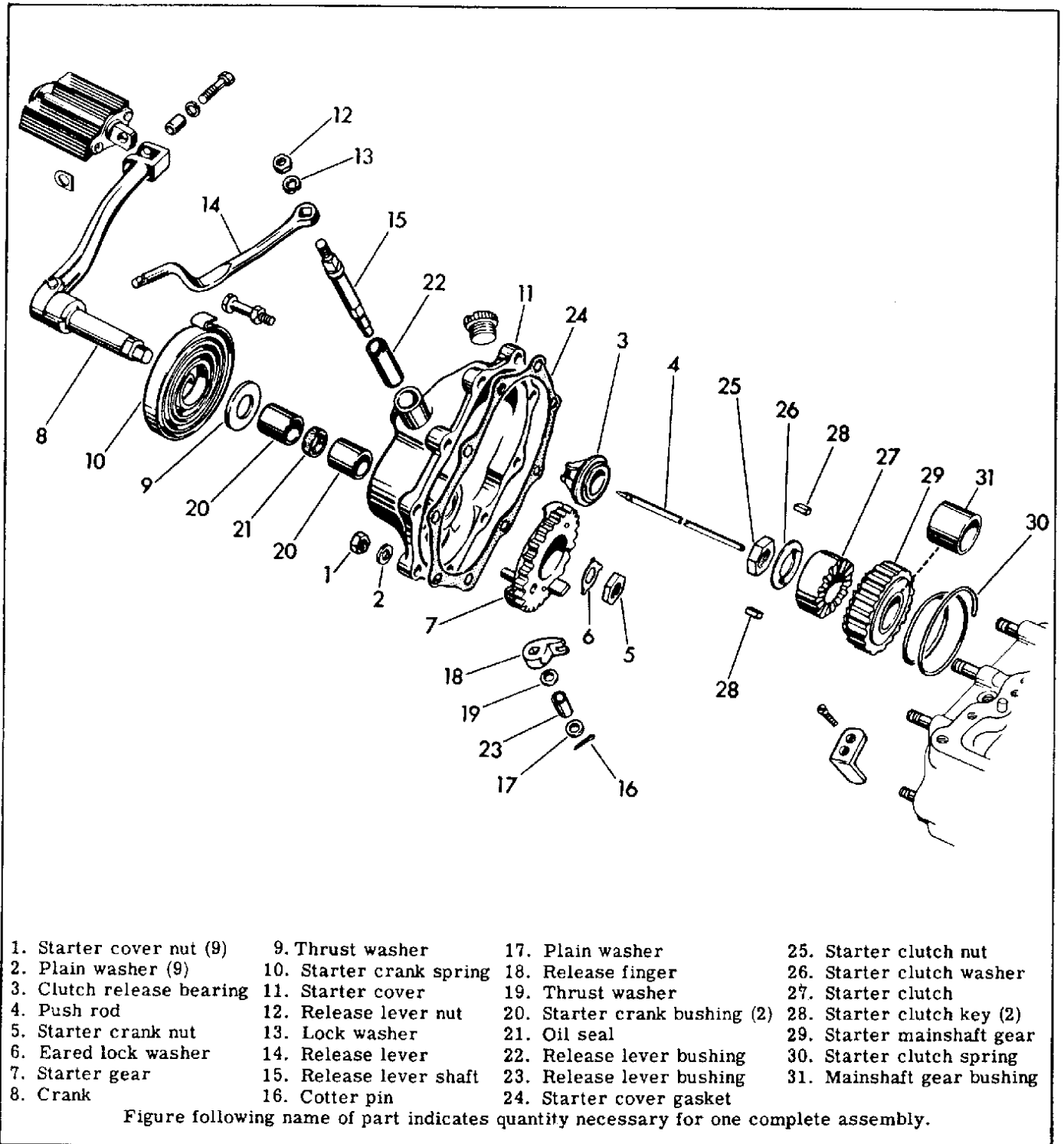

Figure 4C-1. Starter Assembly - Exploded View

Position mainshaft gear (29) on shaft and check play. If obviously loose, replace bushing (31).

#### ASSEMBLING STARTER CLUTCH (Fig. 4C-1)

Coat gasket (24) with Perfect Seal No. 4 and position on gear box. Lubricate mainshaft with engine oil and slip spring (30) and mainshaft gear over shaft. Bushing should be loose enough on mainshaft to allow gear to slide under force of compressed starter

clutch spring. If necessary, line ream bushing to achieve free fit.

Position starter clutch, drive in starter clutch keys and assemble remainder of parts in reverse order of disassembly.

Be careful not to draw down nut (25) too tight. Don't go beyond a point where top of starter clutch is less than 5/8 in. above edge of gear box.

## GEAR BOX

### ADJUSTING SHIFTING LINKAGE

**HAND SHIFT.** The hand shift normally requires adjustment only when transmission has been moved to adjust front drive chain, and then only the shifter rod needs adjustment to maintain correct hand shift lever position.

To adjust hand shift move the shifting lever to third position on four-speed transmissions and to second position on three-speed transmissions.

Disconnect shifter rod from shifter lever; with slight backward and forward movement carefully "feel" the transmission lever into exact position where the shifter spring plunger (inside transmission) seats fully in its retaining notch.

By turning the clevis in or out, carefully refit the shifter rod to the shifting lever without disturbing the shifting lever's exact positioning.

**FOOT SHIFT.** The foot shift normally requires adjustment only when transmission has been moved to adjust front drive chain, and then only the shifter rod needs adjustment to maintain correct foot lever pedal position.

Check to make sure that clamping slot in shifter

lever is in alignment with notch or mark in end of foot shift lever shaft, section 4B.

Adjust length of shifter rod so that the foot lever, when fully depressed, has about 1/16 in. clearance from foot lever cover mounting stud. Length of rod is adjusted by removing shifter rod end bolt, loosening shifter rod end lock nut, and turning rod end farther on or off rod. This rod adjustment is important, as any interference between foot lever and cover mounting stud will prevent full movement of foot lever and full engagement of shifting parts inside transmission.

**ADJUSTING FOOT SHIFTER COVER.** When it is impossible to shift foot shifting mechanism into all gears, adjust as follows:

Disassemble shifter cover parts 1 through 12 as described in "Disassembling Shifter Cover (Foot Shift)," see Fig. 4D-6. Time shifter notches as illustrated in Fig. 4D-8. Loosen screw (14, Fig. 4D-6) and rotate adapter plate (16) until timing notch (Fig. 4D-8) in adapter plate, located at bottom of shifter gear hole, lines up with notch between two shifter gear teeth. Make alignment exact, then tighten adapter plate bracket screw to lock in position. This adjustment can be made with shifter in any gear (not neutral).

Assemble shifter cover in reverse order of disassembly.

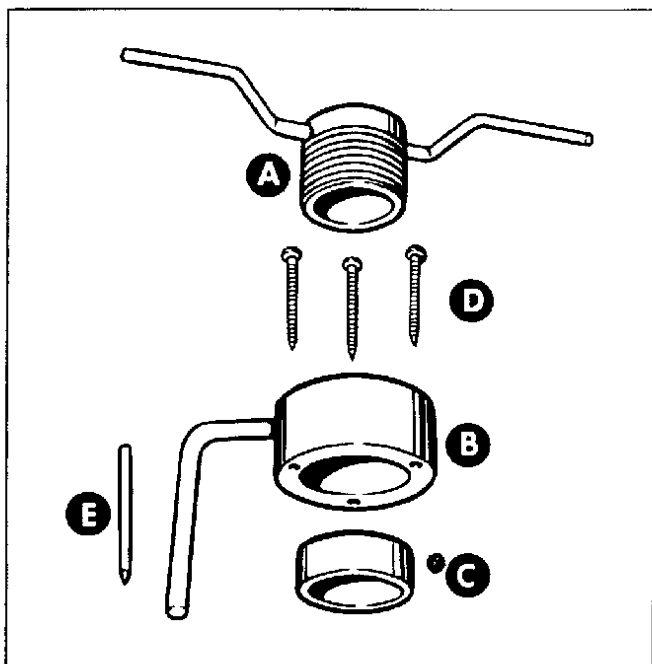

Figure 4D-1. Main Drive Gear Oil Seal Tool

### REPLACING MAIN DRIVE GEAR OIL SEAL

**MAIN DRIVE GEAR OIL SEAL TOOL.** Main Drive Gear Oil Seal Tool, Part No. 95660-42, (Fig. 4D-1) enables removing worn or damaged oil seal and installing new seal without removing or disassembling transmission. It may be used on transmission removed from chassis as well. To use, transmission must be assembled with the exception of clutch and countershaft sprocket.

**REMOVING OIL SEAL.** Shift transmission into low gear and lock rear wheel brake to prevent parts from turning while disassembling.

Remove outer front chain guard, engine sprocket, front chain, clutch assembly, inner chain guard, countershaft sprocket and rear chain.

Place sleeve (C, Fig. 4D-1) on end of main drive gear and slide body (B) over sleeve with body stop rod downward. Turn body clockwise until stop bears against transmission case or mounting plate. Hold body in this position and insert center punch (E) through each of the three holes in body and center punch oil seal as shown in Fig. 4D-2.

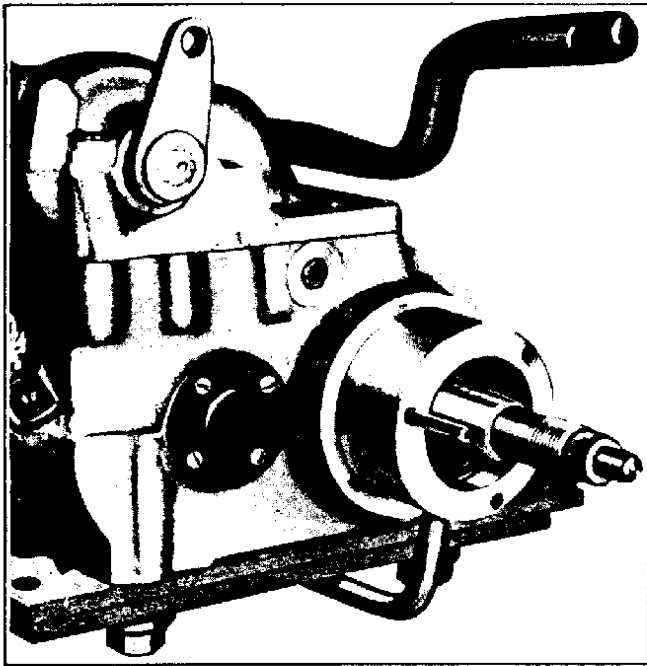

Figure 4D-2. Centerpunching Screw Hole Locations

Remove body and drill a  $\frac{3}{32}$  in. hole through metal face of oil seal at each punch mark. Replace body and insert the three self-tapping screws (D) through body and into oil seal. Tighten screws until body is against oil seal.

Turn actuating screw (A) into body and continue turning as shown in Fig. 4D-3 until oil seal is free. Discard oil seal and oil seal cork washer found behind seal.

**INSTALLING OIL SEAL.** Remove burrs with scraper from outer edge of oil seal recess in transmission

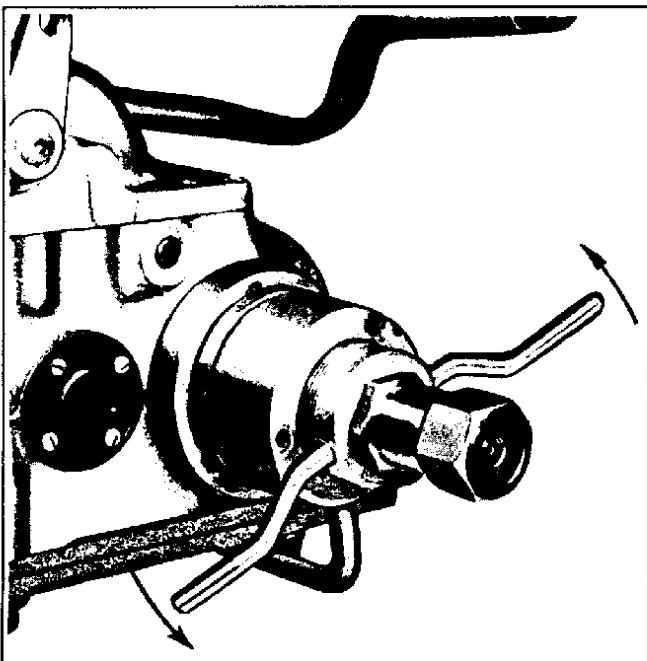

Figure 4D-4. Installing Oil Seal

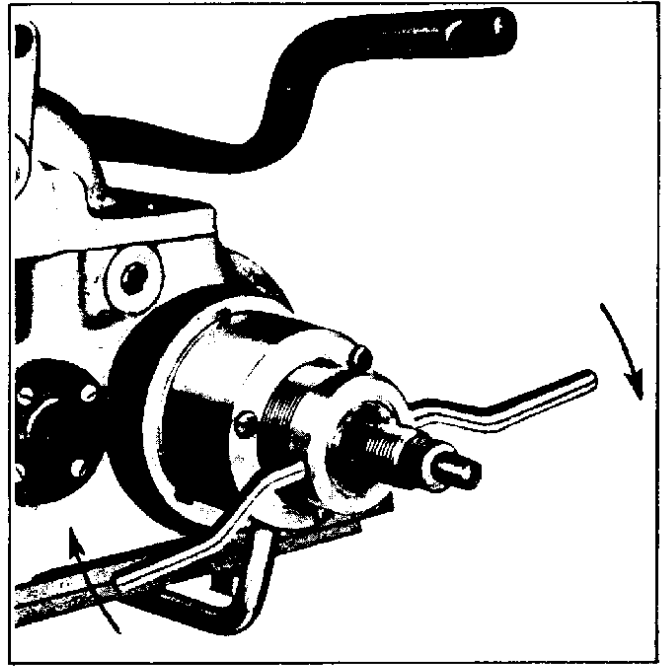

Figure 4D-3. Pulling Oil Seal

where metal was staked to secure seal. Position new cork gasket.

Coat lip of oil seal with oil or grease to prevent damage to new seal.

Insert sleeve (C, Fig. 4D-1) into oil seal. Place sleeve and seal on main drive gear with lip side of seal toward transmission case. Turn seal so it will not stake at same points old seal was staked.

Place body on sleeve and turn actuating screw into body as far as it will go without pulling body away from seal. Install mainshaft clutch hub nut and turn it in against actuating screw as shown in Fig. 4D-4. Back out actuating screw until body has pushed oil seal into place and body is tight against end of gear box.

Remove tool and stake case into notches in seal.

After assembly is complete, check clutch control adjustment.

#### REMOVING SHIFTER COVER

Remove transmission from chassis as described in "Stripping Motorcycle for Transmission Repair," Section 4A.

Remove the 12 screws securing shifter cover to gear box. Shifter cover is registered on two dowel pins. Two of the screws are extra long. Notice that the screw in hole nearest the dowel pin on right side of transmission is vented to relieve gear box heat expansion pressure. This screw must be installed in the same hole when assembling shifter cover or transmission oil may be forced out into clutch.

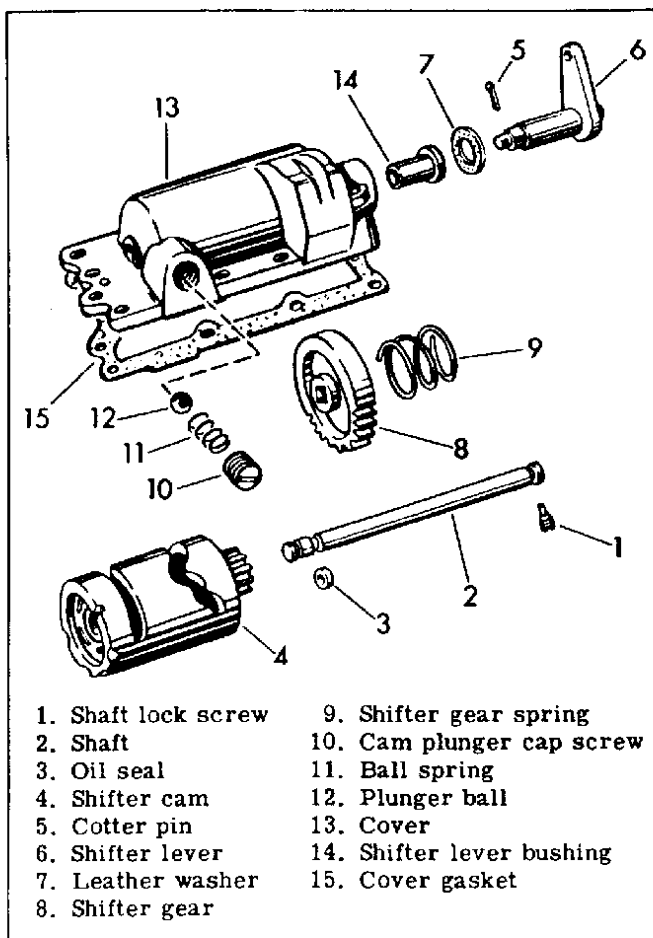

Figure 4D-5. Hand Shifter Cover -  
Exploded View

#### DISASSEMBLING SHIFTER COVER (HAND SHIFT) (FIG. 4D-5)

Remove shaft lock screw (1). Shaft (2) may then be driven out, using the edge of a discarded valve as a drift. Drive on stem end with light hammer taps, with valve head in groove at end of shaft. With shaft removed, shifter cam (4) is free to come out of cover.

Remove cotter pin (5) from shifter lever shaft. Wedge screwdriver between shifter gear and inside of cover. Tap screwdriver in to force gear off shaft. Shifter lever (6) and leather washer (7) can then be pulled out of cover.

Remove cam plunger cap screw (10) and ball spring (11). Plunger ball (12) is then free to drop out of cover (13).

#### CLEANING, INSPECTION AND REPAIR (FIG. 4D-5)

Clean all parts except cam shaft oil seal (3), and shifter lever leather washer in grease solvent and blow dry with compressed air.

Inspect shifter lever fit in bronze bushing (14). Remove worn bushing as follows: Thread a 5/8 in. tap into bushing about 1/2 in. deep. Remove tap and heat

case around bushing to about 300 degrees. Replace tap and clamp in vise. Tap cover with rawhide mallet or block of wood and hammer until cover is driven off bushing.

Inspect gear teeth on shifter cam and shifter gear. If wear is deep, replace parts. Slightly worn parts may be used safely with no impairment to proper function.

Inspect shifter cam slots and plunger ball seats for excessive wear. Cam track and ball seats must be sharp edged. Compare with new part if possible. Replace cam if slots are worn.

Inspect oil seal (3) and cover gasket (15) and replace if broken or in questionable condition.

#### ASSEMBLING SHIFTER COVER (HAND SHIFT)

It is necessary to time shifter lever gear to gear on shifter cam. Install shifter gear spring (9) and shifter gear (8) in cover with spring located over gear hub and timing mark between gear teeth to outside (facing cover bushing). Install shifter cam (4) so notch in gear tooth is aligned with timing mark on shifter gear. Install shifter lever and shaft assembly (6), with square end of shaft in hole in gear with shifting lever pointed toward left, front screw hole in cover, and leather washer (7) between lever and cover bushing.

Insert cotter pin in shaft hole.

Place shifter cam in cover with timing mark on teeth registered with timing mark between teeth on side of shifter lever gear.

Install shifter cam shaft (2) and secure with lock screw. Be sure oil seal is in place in widest groove in right end of shaft. Shifter cam end play should be .0005 in. to .0065 in. If greater, install shim washer of desired thickness. If less than desired amount, file boss in case until recommended play has been achieved.

#### DISASSEMBLING SHIFTER COVER (FOOT SHIFT) (FIG. 4D-6)

Remove three shifter lever screws (1), and remove lever (2) and dust shield (3). Remove five long shifter cover screws (4) and one short screw (5) by removing nut (6) located on rear of adapter plate (16). The pawl carrier cover (7), gasket (8), and pawl carrier (9) are then free to be removed. The pawls (10 and 11), pawl spring (12), and pawl carrier springs (13) are under compression and will pop out when pawl carrier is removed. Remove adapter plate bracket screw (14) and washer (15) to free adapter plate (16) and gasket (17).

Remove neutral indicator switch (18) from cover. Bend back ear on cam follower retainer washer (20) and remove retainer (19), washer (20), spring (21) and cam follower (22).



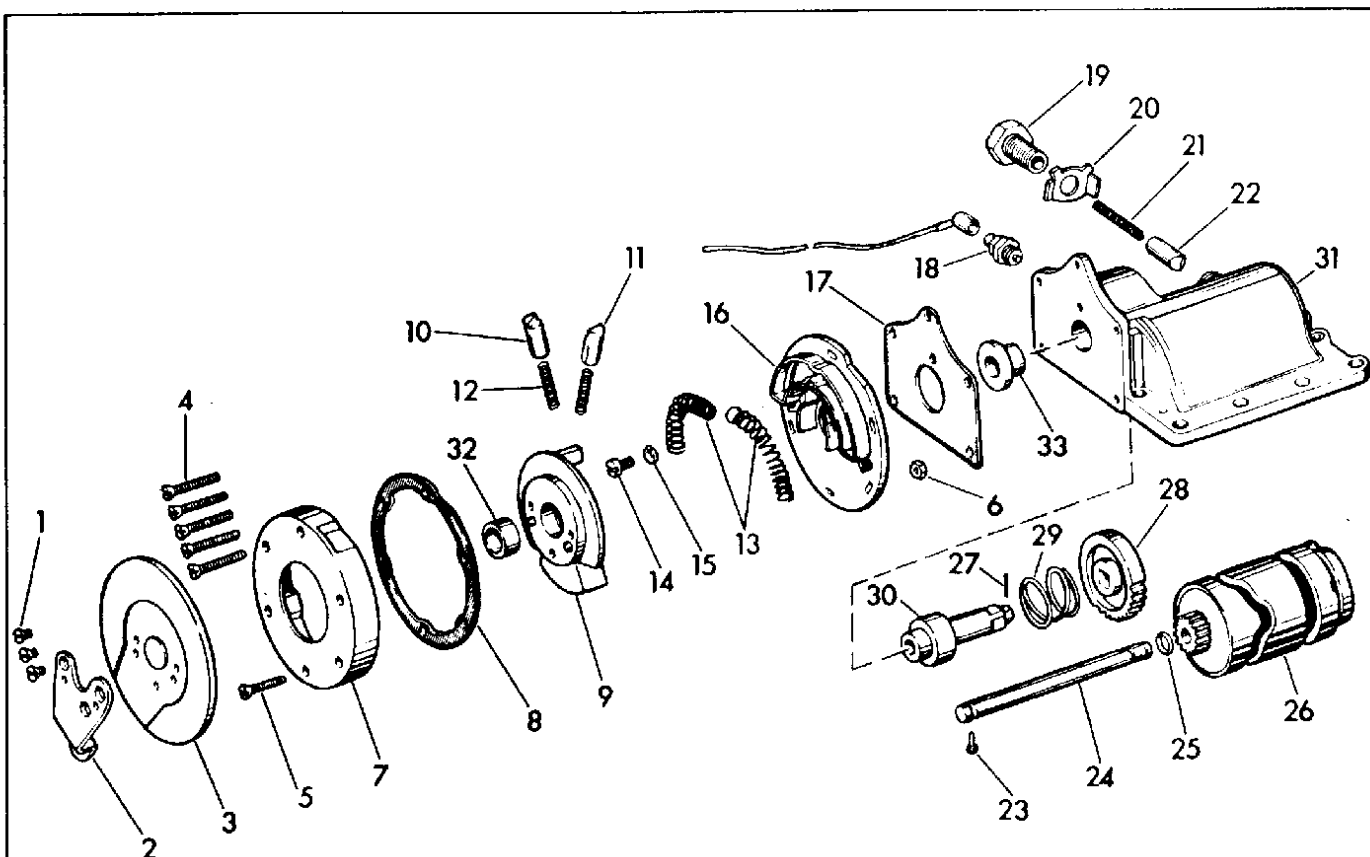

- |                                |  |                           |
|--------------------------------|--|---------------------------|
| 1. Shifter lever screw (3)     | 12. Pawl spring (2)                    | 23. Cam shaft lock screw  |
| 2. Shifter lever               | 13. Pawl carrier spring (2)            | 24. Cam shaft             |
| 3. Dust shield                 | 14. Adapter plate bracket screw        | 25. Oil seal              |
| 4. Shifter cover screw (5)     | 15. Adapter plate bracket screw washer | 26. Shifter cam           |
| 5. Shifter cover screw (short) | 16. Adapter plate                      | 27. Cotter pin            |
| 6. Cover screw nut             | 17. Adapter plate gasket               | 28. Shifter gear          |
| 7. Pawl carrier cover          | 18. Neutral indicator switch           | 29. Shifter gear spring   |
| 8. Cover gasket                | 19. Cam follower retainer              | 30. Shifter shaft         |
| 9. Pawl carrier                | 20. Cam follower retainer washer       | 31. Shifter cover         |
| 10. Pawl (right)               | 21. Spring                             | 32. Pawl carrier bushing  |
| 11. Pawl (left)                | 22. Cam follower                       | 33. Shifter shaft bushing |

Figure following name of part indicates quantity necessary for one complete assembly.

Figure 4D-6. Foot Shifter Cover - Exploded View

Remove cam shaft lock screw (23) from left side of shifter cover joint face. Engage head of old valve in notch in cam shaft and tap end of valve stem to pull cam shaft (24) from cover. Shifter cam (26) may be lifted out of cover.

Remove cotter pin (27) from end of shifter shaft. Remove shifter gear (28) and spring (29) from shaft and pull shaft (30) out of cover (31).

#### CLEANING, INSPECTION AND REPAIR (FIG. 4D-6)

Clean all parts except gaskets (8 and 17), and neutral indicator switch (18) in grease solvent. Clean switch with "Gunk" or gasoline.

Inspect fit of shaft (30) in bushings (32 and 33). If there is considerable side play, replace bushings. Pawl carrier bushing (32) may be pressed out of carrier on arbor press. Shifter shaft bushing (33) is removed as follows: Thread 5/8 in. tap into bushing about 1/2 in. deep. Remove tap and heat shifter cover around bushing to about 300 degrees. Quickly replace tap and clamp tap handle in vise. With rawhide mallet, tap cover near bushing until cover is driven off bushing. Insert new bushing with arbor press or soft metal hammer and wood block. Be sure bushing shoulder is seated against cover.

Inspect teeth on shifter gear and cam. Replace badly worn parts.

Inspect neutral indicator switch. Depress plunger in base of body. It should spring back without a bind. If panel light fails to light in neutral position, plunger is sticking. Switch cannot be repaired, it must be replaced. Do not test switch by passing current through it without having a neutral indicator panel light bulb in the circuit in series.

Inspect all springs. Inspect tips of cam follower (22) and shift pawls (10 and 11). If tips are rounded and worn, replace parts. To function properly these parts must have reasonably sharp tips.

Inspect all parts generally for cracks, bent parts and any wear that would impair intended functions. If hole in pawl carrier is elongated, bushing (32) must be replaced or mechanism will not shift properly.

#### ASSEMBLING SHIFTER COVER (FOOT SHIFT) (FIG. 4D-6)

It is necessary to time the shifter shaft (30) to the shifter gear (28), and the shifter gear to the cam gear on the shifter cam (26). If this is not done correctly, it will be impossible to shift into all gears.

Notice that the timing mark (Fig. 4D-7) cut between the center teeth on one side of shifter gear is in line with the corner of the squared shaft end and just a little to the left of the last ratchet tooth on the shifter shaft. This is the proper timing alignment.

Refer to Fig. 4D-6. Position shifter gear (28) and spring (29) in case, so side of gear with timing mark is toward case. Insert shifter shaft (30) so parts are timed as described above and tap parts together. Insert cotter pin (27).

Install shifter cam (26) in cover so ground timing

mark on top of a tooth registers with timing mark on shifter gear. Slip oil seal (25) on widest of two grooves on end of cam shaft (24) and insert in cover, passing it through shifter cam. Secure shaft with lock screw (23).

Install cam follower (22), spring (21), retaining washer (20) and retainer (19). Install neutral indicator switch (18) and check to make sure button on shifter gear contacts plunger in base of switch.

Position cover (31) in vise with shifter mechanism end upward. Place gasket (17) and adapter plate (16) over cover. Insert adapter plate bracket screw (14) and washer (15) in hole directly above end of shifter gear but do not tighten. Shift gear shift cam to any position but neutral. Rock cam back and forth to make sure spring loaded cam follower is seating exactly in one of the indexing notches, or "V's," that determine cam position for one of the four gears.

Rotate adapter plate until timing notch (Fig. 4D-8) in adapter plate, located at bottom of shifter gear hole, lines up with notch between two bottom shifter gear teeth. Make alignment exact, then tighten adapter plate bracket screw to lock in position.

Apply a light coat of "Grease-All" grease to curved springs (13) and insert them in slots on adapter plate. Grease ratchet end of shifter shaft. Lubricate pawls (10 and 11) with light oil after checking to see if they are free in holes in pawl carrier (9). Install pawl springs (12) and pawls in pawl carrier so notches in ends of pawls face inward or toward each other.

Install pawl carrier with pawls over end of shifter shaft with lug on pawl carrier inserted between ends of pawl carrier springs.

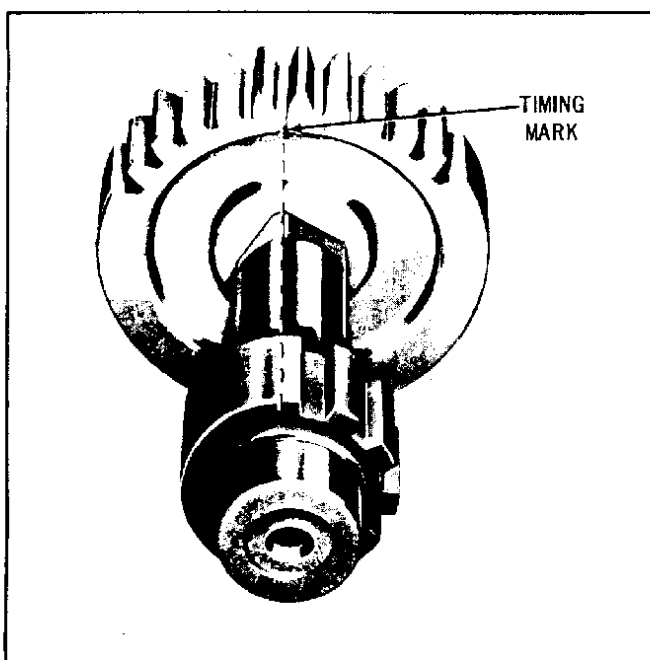

Figure 4D-7. Timing Shifter Gear

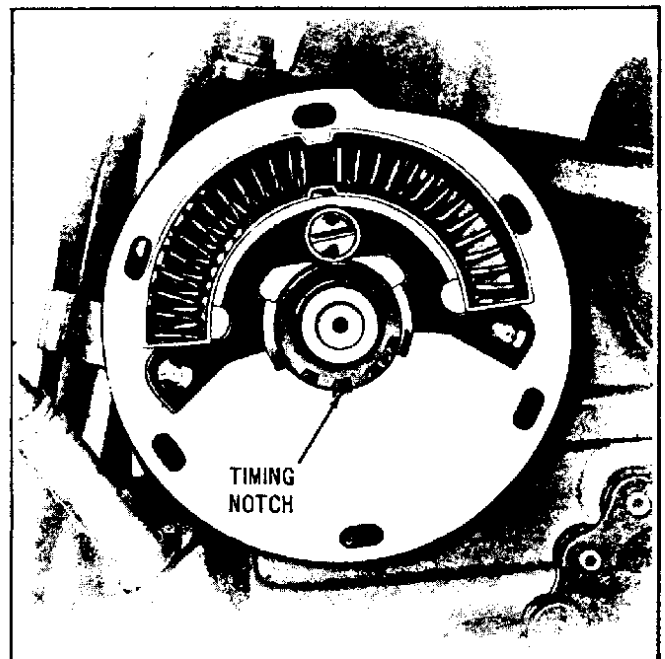

Figure 4D-8. Timing Shifter Notches

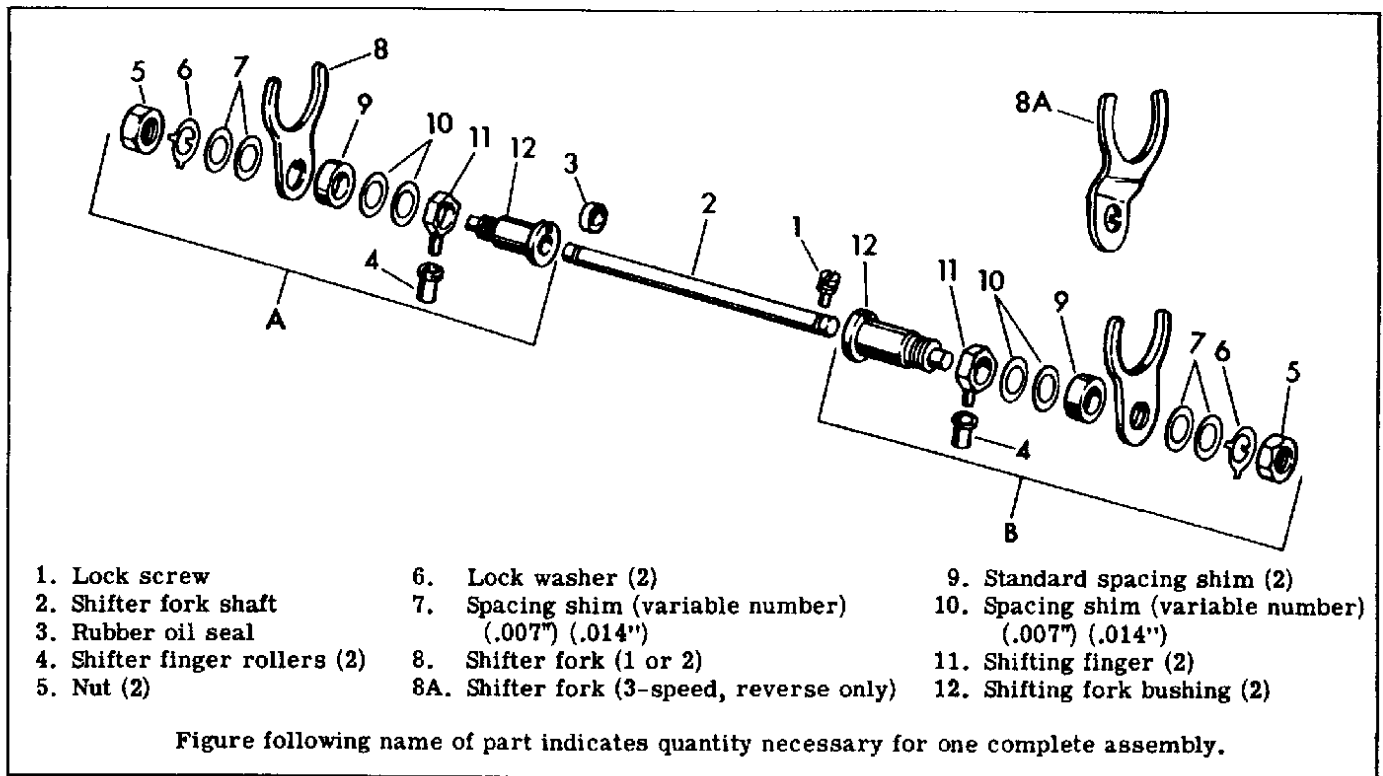

Figure 4D-9. Shifter Fork - Exploded View

Lubricate back of pawl carrier with "Grease-All" grease and install cover gasket (8) and cover (7) so notches at top line up with corresponding notch on adapter plate. Apply Loctite sealant,

to threads of shorter screw (5) and insert through bottom hole. Secure with nut (6) on back of adapter plate. Apply Loctite sealant to threads of five long screws (4) and tighten all screws.

Position cover dust shield (3) over dowel pins on pawl carrier. Position shifter shaft lever (2) over dowel pins and secure with three shifter shaft lever screws (1). Also treat the threads of these screws with Loctite sealant before inserting.

#### REPLACING SHIFTER COVER

Coat shifter cover gasket with Perfect Seal No. 4 and position on gear box. Install assembled shifter cover over gear box opening and secure with twelve screws. Note that two screws are longer. They are inserted in holes adjacent to bulge in cover over shifter gear. The short cover screw with vent hole is inserted in hole nearest locating dowel pin on right side of gear case. Use Loctite sealant on all screw threads except the single vent screw.

#### REMOVING SHIFTER FORKS (FIG. 4D-9)

Remove shifter cover as described in "Removing Shifter Cover."

Shifter fork shaft (2) is held in position by lock screw (1) which may be found in gear box cover joint surface in line with right end of shaft. With lock screw (1) removed, shaft may be driven out by means of a

drift inserted in hole in starter cover joint face of gear box. Notice that a rubber oil seal (3) is assembled in groove on left end of shifter fork shaft.

Shifter fork assemblies (A and B) are not interchangeable. Note exactly the arrangement of parts and components in each. Keep parts separate to avoid needless adjusting when reassembling. If inspection shows fork assemblies are not damaged, worn or bent, it may not be necessary to disassemble them unless shifter clutches are replaced. Adjustments are described in "Assembling Shifter Forks."

#### DISASSEMBLING SHIFTER FORKS (FIG. 4D-9)

If it is necessary to disassemble shifter forks, lift off shifter finger rollers (4), pry back ear on lock washer (6) and turn off nut (5). Lift washer (6), a number of .014 in. or .007 in. spacing shim washers (7) which varies from one fork assembly to another, shift forks (8), 5/64 in. thick standard spacing shim (9), more .007 in. or .014 in. spacing shims (10), shifting fingers (11) and shifting fork bushings (12).

#### CLEANING, INSPECTION AND REPAIR

Clean all parts in cleaning solvent and blow dry with compressed air.

If shifter forks are bent or worn, replace them. Straightened forks are weak. They may break and cause extensive damage to gear box parts.

Check fit of shifter fork bushings on shaft. If bushings are loose enough to give fork action lash, replace them. Check replacement part fit on shaft.

Lap out bushings if they bind. Shifting will be difficult unless bushings work freely on shaft.

#### ASSEMBLING SHIFTER FORKS

Assemble shifter forks in reverse of disassembly order making sure parts are not transposed.

Check adjustment of shifter forks with Fork Shifter Gauge, Part No. 96384-39, by placing shifter gauge on shifter cover as shown in Fig. 4D-10. With the 3/8 in. gauge rod furnished, set tool gauge blocks in exact alignment with straight sections of cam slots in shifter cam. Lock gauge blocks in place with thumb screws.

Remove tool from cover, turn it over, and place it on transmission case with shifter fingers engaged in slots on gauge blocks as shown in Fig. 4D-11. Be sure shifter finger rollers are in place on shifter fingers.

With thickness gauges, check clearance on both sides of shifting clutches. All shifting clutches must be centered.

When clearances are not equal and correct, shifting fork assemblies must be corrected by increasing or decreasing the number of shims between shifter fork and shifter finger. To make this adjustment, remove shifter fork assemblies from transmission. Shims are available .007 in. and .014 in. thick.

After taking out or adding shims, be sure fork assembly lock nut is tight. However, excessive tightening may close up hole in bushing so it is no longer a free, sliding fit on shaft.

Clearances between shifter clutch and gear are as follows:

Low and second gear: When centered between gears to have .075 in. clearance on both sides.

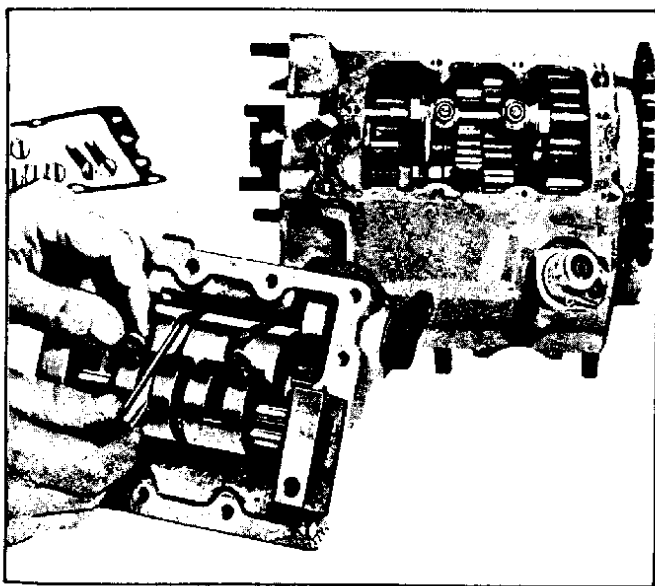

Figure 4D-10. Adjusting Shifter Gauge

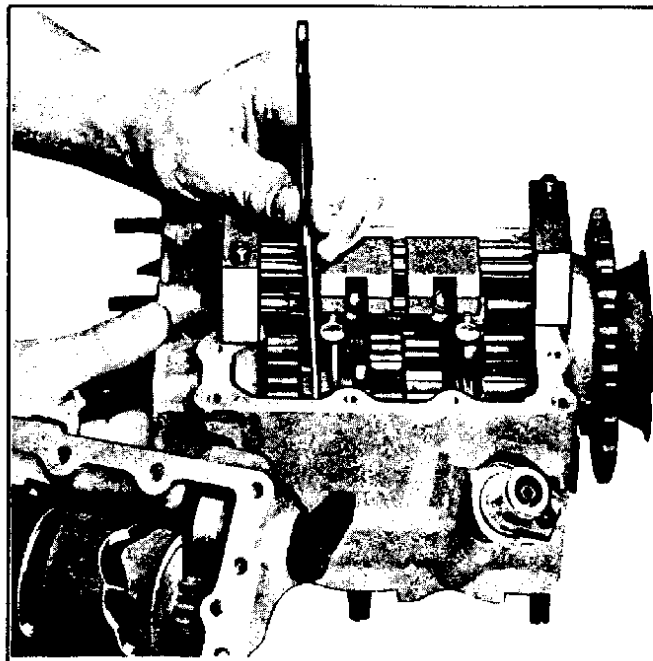

Figure 4D-11. Checking Shifter Clutch Clearance

Third and high gear: When centered between gears to have .100 in. clearance on both sides.

Sliding reverse gear: When centered between gears to have approximately .055 in. clearance between gear teeth.

Where shifter clutch engagement is with dogs protruding from face of gear, turn gear so dogs on shifter clutch and dogs on gear are overlapping each other about 1/8 in. before checking clearance.

Place shifter forks in gear box and install shifter fork shaft. Fork with narrow opening is for high gear shifter clutch. Install shifter shaft lock screw.

Assemble shifter cover to gear box as described in "Replacing Shifter Cover."

#### DISASSEMBLING GEAR BOX (FOUR SPEED)

Remove transmission from chassis as described in "Stripping Motorcycle for Transmission Repair," Section 4A.

Remove clutch as described in "Disassembling Clutch,"

Remove starter assembly and starter clutch as described in "Disassembling Starter," Section 4C.

Remove shifter cover and shifting forks as described in "Removing Shifter Cover" and "Removing Shifter Forks."

#### DISASSEMBLING COUNTERSHAFT (Fig. 4D-12)

Remove four screws (1) and washers (2) holding countershaft end cap (3) and gasket (4) to left (clutch)

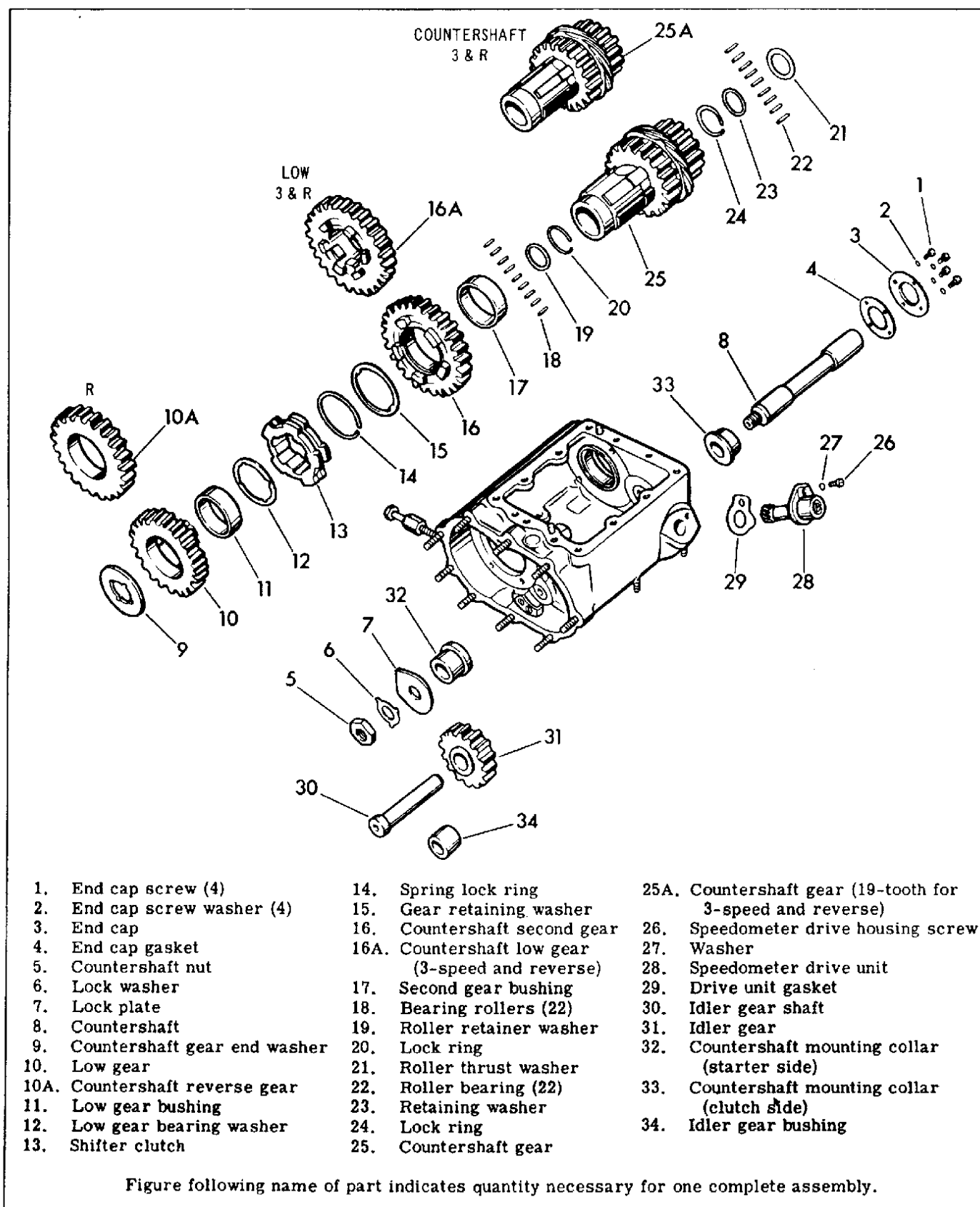

Figure 4D-12. Countershaft Assembly - Exploded View

side of gearcase. Bend ear of lock washer away from flat of nut and remove countershaft nut (5), lock washer (6) and countershaft lock plate (7). Countershaft (8) may then be driven out of case toward left side with appropriate-size drift pin, freeing countershaft gear assembly consisting of parts 9 through 25. When countershaft gear assembly needs no repair, it should not be disassembled. With shaft out, countershaft gear end washer (9) will drop into case unless some provision for catching it is made before extracting countershaft.

Disassemble countershaft gear assembly as follows:

Lift low gear (10), low gear bushing (11), low gear bearing washer (12) and shifter clutch (13) off splined countershaft.

Remove spring lock ring (14), gear retaining washer (15), countershaft second gear (16) and second gear bushing (17).

Remove the 22 bearing rollers (18) and roller retainer washer (19) from shaft hole in countershaft gear. Use knife blade or thin screwdriver to remove lock ring (20).

Remove roller thrust washer (21), 22 rollers (22), retaining washer (23) and lock ring (24) from opposite end of countershaft gear (25).

When disassembling countershaft gear assembly, be sure all rollers are accounted for and roller set from each end of gear is wrapped separately in paper

or cloth, marked for end of gear from which it was removed.

### CAUTION

If any of the rollers are lost or if sets become mixed, both sets will have to be replaced with new parts even though in serviceable condition.

Remove speedometer drive housing screw (26) and washer (27) and lift out speedometer drive unit (28) and gasket (29) from gear case.

If a three-speed and reverse transmission, remove idler gear shaft (30) and idler gear (31). Thread a 1/4-20 tap screw into end of shaft, grasp screw head in pliers and pull shaft out of case. It may be necessary to heat the case to facilitate pulling the shaft.

### DISASSEMBLING MAINSHAFT (Fig. 4D-13)

Remove the four bearing housing retaining plate screws (1), oil deflector (2) and retaining plate (3).

Drive mainshaft assembly toward right side of case with rawhide mallet or block of wood and hammer until mainshaft bearing (6) or bearing housing (7) with bearing are just free of opening in case. With screwdriver or other suitable tool, pry lock ring (12) out of groove in mainshaft and slide it onto mainshaft splines. Pull ball bearing nut (4), ball bearing washer (5), ball bearing (6), bearing housing (7), low and second gear assembly (8) and mainshaft (9) out

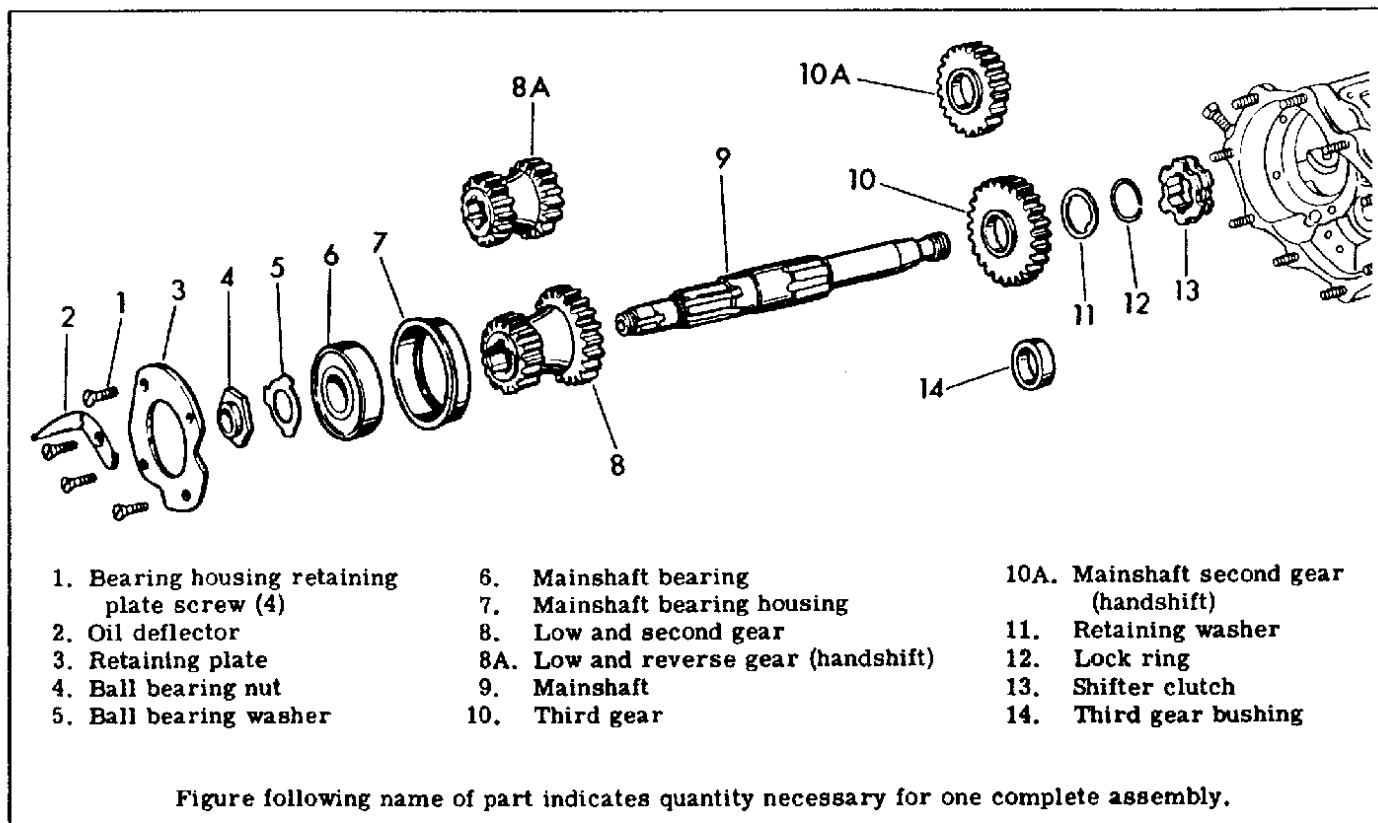

Figure 4D-13. Mainshaft Assembly - Exploded View

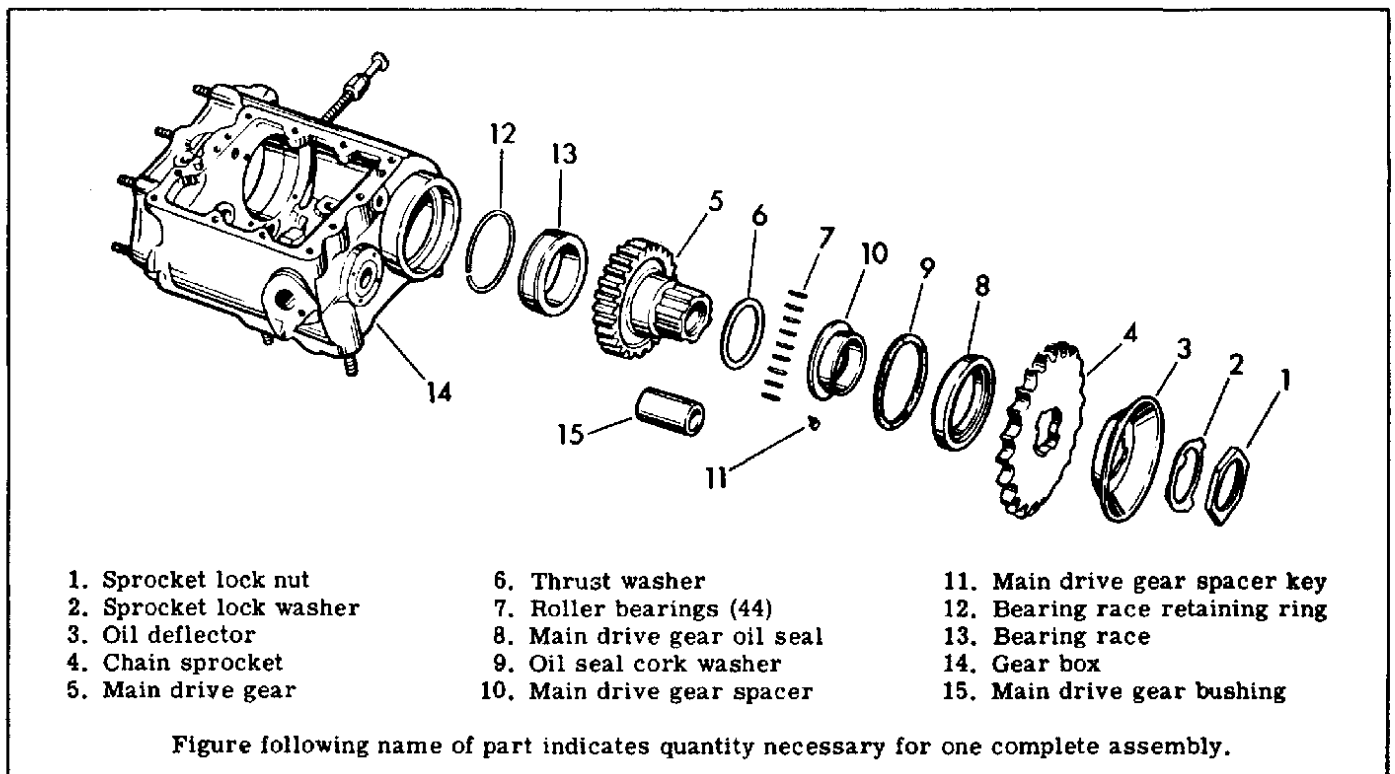

Figure 4D-14. Main Drive Gear - Exploded View

right side of case, slipping third gear (10), retaining washer (11), spring lock ring (12) and shifter clutch (13) off left end of mainshaft and out through shifter cover opening in case.

If bearing housing does not come out with bearing when mainshaft assembly is being removed, slide gear (8 or 8A) along mainshaft until edge of large gear is against bearing housing and drive out housing together with mainshaft. To avoid damage to case, make sure gear is positioned so it does not overlap housing.

Disassemble the mainshaft gear and ball bearing assembly only if inspection shows a need for replacing worn or damaged parts.

Clamp mainshaft in copper-faced vise jaws. Bend ear of lock washer (5) away from flat of nut (4) and remove nut and washer. Bearing (6) and gear (8) may then be removed with the All Purpose Claw Puller, Part No. 95635-46 or an arbor press. If using claw puller, insert center adapter, Part No. 95636-46, into end of shaft to prevent damage to shaft. Bearing and gear are removed separately.

#### DISASSEMBLING MAIN DRIVE GEAR (FIG. 4D-14)

Position gear box in vise and nail or bolt length of rear chain to bench. Engage chain on sprocket teeth to keep sprocket from turning.

Bend ear of lock washer away from flat of nut and remove sprocket lock nut (1) and washer (2). Nut has left hand thread. Lift oil deflector (3) and chain sprocket (4) off gear. Push main drive gear (5) into

case and withdraw it from top. Thrust washer (6) usually comes out with gear. Remove the 44 roller bearings (7). Be sure all rollers are accounted for and wrap them in paper or cloth. If any of these rollers are lost or if rollers from another bearing become mixed with them, the entire set must be discarded and a new set fitted, even though the old rollers are in serviceable condition.

Do not remove main drive gear oil seal (8) or main drive gear spacer (10) unless inspection shows damage or wear. Complete instructions for removing oil seal and spacer may be found in Section 4D.

#### CLEANING, INSPECTION AND REPAIR

Clean all parts except gaskets (all gaskets should be replaced) with cleaning solvent and blow dry with compressed air.

Inspect all gears. If teeth are pitted, scored, cracked, chipped or if case hardening is worn through, replace with new gears.

Inspect all bushings, bearing races and shafts. If bent or worn, install new parts. If mainshaft ball bearing (6, Fig. 4D-13) is worn to point where play is obviously too great, install new bearing.

To install main drive gear bearing race (13, Fig. 4D-14), heat case to about 300 degrees and press out old race with arbor press after removing bearing race retaining ring (12). Reheat case and press in new race until flange is seated against case. Install new bearing race retaining ring.

Oil seal cork washer (9) and oil seal (8) should not be reinstalled if they have been removed. An oil leak will probably develop. Use new parts.

Carefully check shifter clutches (13, Fig. 4D-12 and 4D-13) and engaging dogs on gears. If they are rounded or battered appearing, they must be replaced.

Worn shifter clutch and gear dogs result from shifting abuses or from out-of-adjustment clutch that does not release fully. Damaged engaging dogs try to creep out of engagement under a steady load. This creeping action develops great side pressure that results in damage to shifting mechanism and all thrust points along shaft assemblies.

Check bearings (7, Fig. 4D-14 and 18, 22, Fig. 4D-12) for proper fit in races according to tolerances shown in "Transmission Specifications," Section 4A. Replacement rollers are available standard, .0004 in. and .0008 in. oversize.

#### ASSEMBLING GEAR BOX (FOUR SPEED)

##### ASSEMBLING MAIN DRIVE GEAR (FIG. 4D-14)

Assuming that main drive gear oil seal (8), oil seal cork washer (9) and gear spacer (10) are assembled in case (replacing these parts must be done before gear box is disassembled or after it is repaired and assembled as described in Section 4A), install rollers (7) in bearing outer race (13), holding rollers in place with a light coat of grease.

Install main drive gear thrust washer (6) on main drive gear. Insert main drive gear (5) into gear box. Be sure rollers stay in place as gear is inserted.

Install main drive gear spacer key (11), registering longer section of key in any splineway on main drive gear and shorter section of key in slot in outer edge of main drive gear spacer.

Install sprocket (4) with flat side outward. Install oil deflector (3), lock washer (2) and sprocket lock nut (1). Hold sprocket as outlined in disassembly procedure and tighten nut securely. Check main drive gear assembly end play. See "Transmission Specifications," Section 4A, for proper tolerances. Bend one ear of lock washer against flat of nut.

##### ASSEMBLING MAINSHAFT (FIG. 4D-13)

Assemble parts 4 through 8 to mainshaft before installing mainshaft in gear case. Position gear (8) on shaft splines. Press or fit ball bearing housing (7) over ball bearing (6) and press onto shaft. Assemble lock washer (5) and nut (4) to shaft and tighten securely. Bend over one ear of lock washer against flat of nut.

Insert mainshaft assembly into gear box far enough to install gear (10), thrust washer (11) lock ring (12) and shifter clutch (13) over shaft. Always install new lock rings and make sure they are properly seated in lock ring groove. One side of mainshaft shifter

clutch is stamped "HIGH." Make sure this side faces main drive gear.

With a screwdriver or other suitable tool, work lock ring onto shaft splines. Use screwdriver wedged against shifter clutch to force lock ring into seat in shaft.

With a soft-metal hammer or brass drift, tap mainshaft assembly into case until flange on ball bearing housing is shouldered against case. Install retaining plate (3), oil deflector (2) and four screws (1).

If working on three-speed transmission, install reverse idler gear (31, Fig. 4D-12) and shaft before installing retaining plate.

#### ASSEMBLING COUNTERSHAFT (FIG. 4D-12)

Before installing countershaft gear train to shaft and case, it is necessary to check bearing fit and shaft end play.

If countershaft mounting collars (32 and 33) were removed for replacement, press or drive old parts out and new parts in after gear case has been heated to approximately 300 degrees to expand case and facilitate pressing.

Install roller sets (18 and 22) in countershaft gear (25), holding them in place with a coat of grease. Be sure lock rings (20 and 24) and bearing retaining washers (19 and 23) are in place before installing bearings. Install bearing thrust washer (21) in its recess in left end of countershaft gear. Install countershaft temporarily to check bearing fit. See "Transmission Specifications," Section 4A, for tolerances.

Install countershaft gear in case holding end play adjusting washer (9) in place with daub of heavy grease. Install countershaft.

Check end play with feeler gauge between end play adjusting washer and end of countershaft gear. Consult transmission specifications for tolerances. Increase or decrease end play as necessary by fitting end play adjusting washer of required thickness. Washers are available in thicknesses of .074, .078, .082, .085, .090, .095 and .100 in. When correct gear end play has been established, remove countershaft and gear from case. Set aside adjusting washer until needed for assembly.

Install gear bushing (17), gear (16), thrust washer (15) and gear lock ring (14) on countershaft gear (25).

Install shifter clutch (13), thrust washer (12), gear bushing (11) and gear (10) on countershaft gear. Check to make sure all rollers are in place in gear.

Place end play adjusting washer (9) on end of countershaft gear, holding in position with daub of grease. Position assembly in case and insert countershaft (8) and lock plate (7). Straight edge of lock plate fits against edge of bearing retaining plate (3, Fig. 4D-13). Install lock washer (6) and nut (5). Tighten nut se-



curely and bend over one ear of lock washer against flat of nut.

Install gasket (4) and end cap (3) with washers (2) and screws (1). Install gasket (29), drive unit (28), washer (27) and screw (26).

Install shifter cover, starter clutch, starter cover and clutch as described in pertinent sections.

Assemble transmission to motorcycle and connect controls in reverse order of stripping procedure described in "Stripping Motorcycle for Transmission Repair," Section 4A.

#### DISASSEMBLING GEAR BOX (THREE-SPEED AND REVERSE)

A three forward speed and reverse transmission cannot be installed on a foot shift model motorcycle, and

a three-speed transmission cannot be assembled in a four-speed gear case.

The disassembly, repair and assembly procedures for a three-speed and reverse transmission are the same as for a four-speed transmission except for the procedures described in operations to four-speed model and following differences:

Refer to Fig. 4D-12. In three-speed and reverse countershaft assembly, omit shifter clutch (13), lock ring (14), thrust washer (15) and gear bushing (17).

Substitute gear 10A for 10, 16A for 16, and 25A for 25.

Refer to Fig. 4D-13. Substitute 8A for 8 and 10A for 10.

Refer to Fig. 4D-9. Substitute 8A for 8.

# SHOP DATA:

## TRANSMISSION VENT SCREW

A new method of venting the transmission is being used on the 1956-74 OHV Model.

Transmission vent plug, part No. 34720-36, formerly located on the top right side of the transmission case near the kick starter crank, is no longer used, and the threaded hole into which it was screwed has been eliminated.

The new venting method employs a drilled screw, part No. 34720-56, which is installed in the second screw hole from the front on the starter crank (right) side of the transmission cover. This screw, recognized by a hole in the side of the screw head, must be installed in the cover in its proper position. Unless this is done, the transmission either will not be vented resulting in oil leakage past the starter and mainshaft bearings, or oil may be discharged through the vent.

# ELECTRICAL

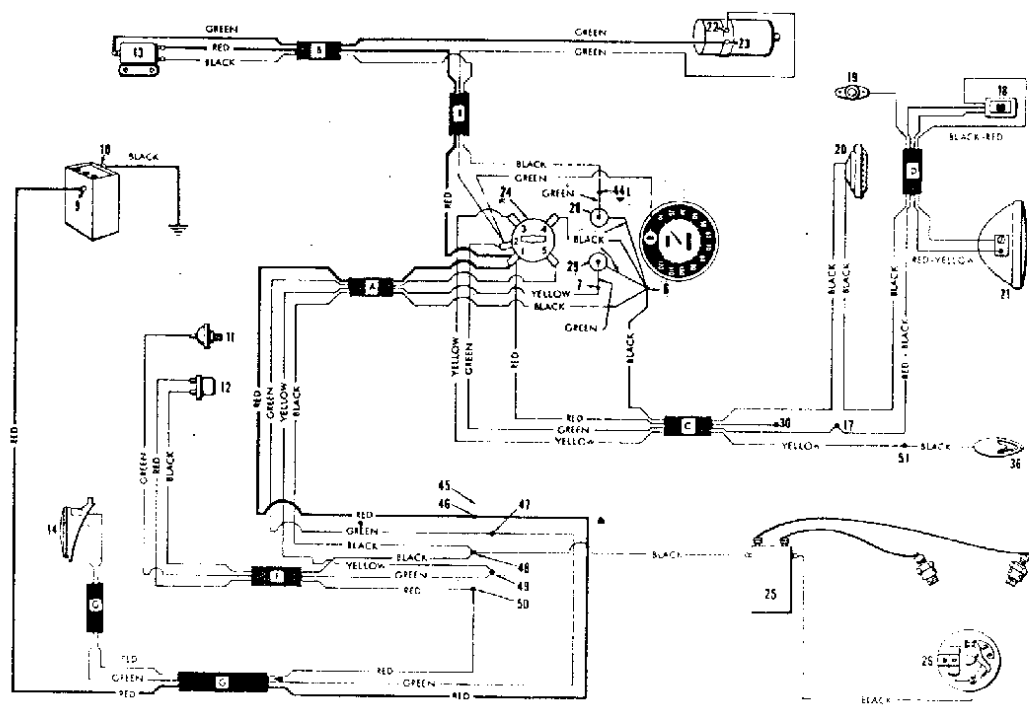

1948  
Key for Wiring Diagram

- A. FOUR WIRE CABLE - Red wire, green wire, black wire, yellow wire.
- B. THREE WIRE CABLE - Red wire, green wire, black wire.
- C. FOUR WIRE CABLE - Red wire, green wire, yellow wire, black wire.
- D. LOOM (four wires) - Black wire with red tracer; red wire with yellow tracer; red wire with black tracer; black wire.
- E. THREE WIRE CABLE - Black wire, green wire, red wire.
- G. LOOM (three wires) - Red wire, green wire, red wire.
- 1. SWITCH TERMINAL - Cable "A" red wire from junction terminal (46); cable "B" red wire from relay (13); cable "C" red wire from junction terminal (30).
- 2. SWITCH TERMINAL - Cable "C" green wire from junction terminal (11); cable "B" green wire from generator "switch" terminal (22); green wire from speedometer light (8).
- 3. SWITCH TERMINAL - Cable "C" yellow wire from junction terminal (51).
- 4. SWITCH TERMINAL - Cable "A" green wire from junction terminal (47).
- 5. SWITCH TERMINAL - Black wire from junction terminal (6).
- 6. JUNCTION TERMINAL - Cable "C" black wire from horn (20); black wire from oil signal light (29); black wire from generator signal light (28); black wire from switch terminal (5); cable "A" black wire from junction terminal (48).
- 7. JUNCTION TERMINAL - Cable "A" yellow wire from terminal (49); green wire from oil signal light (29).
- 8. SPEEDOMETER LIGHT - Green wire from switch terminal (2).
- 9. BATTERY POSITIVE TERMINAL (left side) - Loom "G" red wire from junction terminal (46).
- 10. BATTERY NEGATIVE TERMINAL (right side) - Black wire from ground terminal on frame.
- 11. OIL PRESSURE SIGNAL SWITCH - Cable "E" green wire from junction terminal (49).
- 12. STOP LAMP SWITCH - Cable "F" red wire from junction terminal (30); cable "F" black wire from junction terminal (48).
- 13. RELAY - Cable "B" red wire from switch terminal (1) to relay terminal marked "BAT"; cable "B" black wire from junction terminal (44); cable "B" green wire from generator "relay" terminal (23).
- 14. TAIL AND STOP LAMP - Loom "G" red wire from junction terminal (50); loom "G" green wire from junction terminal (47).
- 17. JUNCTION TERMINAL (front terminal-left side, in headlamp bracket) - Cable "C" green wire from switch terminal (2); loom "D" red wire with black tracer from handlebar toggle switch (18).
- 18. HANDLEBAR TOGGLE SWITCH - Loom "D" black wire with red tracer from headlamp larger terminal screw; loom "D" red wire with yellow tracer from headlamp smaller terminal screw; loom "D" red wire with black tracer from junction terminal (17).
- 19. HORN SWITCH - Loom "D" black wire from horn (20).
- 20. HORN - Cable "C" black wire from junction terminal (6); loom "D" black wire from horn switch (19).
- 21. HEADLAMP - Loom "D" black wire with red tracer from handlebar toggle switch (18) to larger terminal screw; loom "D" red wire with yellow tracer from handlebar toggle switch (18) to smaller terminal screw. NOTE: Headlamp is shown in upside down position.
- 22. GENERATOR "SWITCH" TERMINAL - Cable "B" green wire from switch terminal (2).
- 23. GENERATOR "RELAY" TERMINAL - Cable "B" green wire from relay (13).
- 24. IGNITION-LIGHT SWITCH (top view) - Switch positions for off, ignition only, ignition and running lights and parking lights are shown in Figure 4. Switch can be locked in off and park positions only, using head lock key, a cot, or knife blade.
- 25. IGNITION COIL - Black wire from junction terminal (48); black wire from circuit breaker (28).
- 26. IGNITION CIRCUIT BREAKER - Black wire from coil rear terminal.
- 28. GENERATOR SIGNAL LIGHT (marked "GEN") - Black wire from junction terminal (6); green wire from junction terminal (44).
- 29. OIL PRESSURE SIGNAL LIGHT (marked "OIL") - Black wire from junction terminal (6); green wire from junction terminal (7).
- 30. JUNCTION TERMINAL (front terminal - right side, in headlamp bracket) - Cable "C" red wire from switch terminal (1). This is a live terminal and can be used for accessory lamps independent of ignition-light switch.
- 36. MUDGUARD LAMP - Black wire from junction terminal (51).
- 44. JUNCTION TERMINAL - Green wire from generator signal light (28); cable "B" black wire from relay (13).
- 45. JUNCTION BOX - Located behind ignition coil.
- 46. JUNCTION TERMINAL (upper left side terminal in junction box) - Cable "A" red wire from switch terminal (1); loom "G" red wire from battery positive terminal (9).
- 47. JUNCTION TERMINAL (upper right side terminal in junction box) - Cable "A" green wire from switch terminal (4); loom "G" green wire from tail and stop lamp (14).
- 48. JUNCTION TERMINAL (center left side terminal in junction box) - Cable "A" black wire from junction terminal (6); cable "E" black wire from stop lamp switch (12); black wire from coil front terminal.
- 49. JUNCTION TERMINAL (lower right side terminal in junction box) - Cable "A" yellow wire from junction terminal (7); cable "F" green wire from oil pressure signal switch (11).
- 50. JUNCTION TERMINAL (lower left side terminal in junction box) - Loom "G" red wire from tail and stop lamp (14); cable "F" red wire from stop lamp switch (12).
- 51. JUNCTION TERMINAL (in front mudguard and horn bracket) - Black wire from mudguard lamp (36); cable "C" yellow wire from switch terminal (3).

NOTE: Side Car Tail and Stop Lamps - In sidecar or package trunk service, if the sidecar or package truck is equipped with a tail and stop lamp, the green wire of the lamp cable is connected to terminal No. 47 and red wire to terminal No. 50 in the junction box (45).

Key for Wiring Diagram

- A. FOUR WIRE CABLE -- Red, Green, Black and Yellow wires from switch and instrument panel base terminals #1, #4, #6 and #7. Right front cable in panel base, to terminal box behind ignition coil.
- B. THREE WIRE CABLE -- Red, Green, and Black wires from switch and instrument panel base terminals #1, #2 and #44. Left cable in panel base, to generator and cut out relay.
- C. FOUR WIRE CABLE -- Red, Green, Yellow and Black wires from switch and instrument panel base terminals #1, #2, #3 and #8. Right rear cable in panel base, to terminal plate on fork.
- D. HANDLEBAR WIRING (Loose Wires) -- Red wire with black tracer, Black wire with red tracer and Red wire with yellow tracer, from handlebar switch on handlebar to terminal plate terminals #2, #21 and #22. Black wire from Horn Switch to terminal plate terminal #25.
- E. TWO WIRE CABLE -- Red and Green wires from terminal plate terminals #24 and #25 to horn.
- F. THREE WIRE CABLE -- Black, Green and Red wires from terminal box, terminals #41, #42, #43 to oil pressure switch and stop lamp switch.
- G. LOOM -- (Three wires) -- Red, Green and Red wires from terminal box terminals #39, #40 and #43.
- H. LOOM -- (two wires) -- Black and Red wires from terminal plate terminals #21 and #22 to head lamp.
- J. LOOM -- (two wires) -- Red and Green wires, continuation from 2 wire loom (G) to tail lamp.
- 1. SWITCH TERMINAL - Red wire through cable "A" to terminal (30); red wire through cable "B" to relay (13); red wire through cable "C" to terminal (14).
- 2. SWITCH TERMINAL - Green wire through cable "C" to terminal (8); green wire through cable "B" to generator "switch" terminal (32); green wire to speedometer light (8).
- 3. SWITCH TERMINAL - Yellow wire through cable "C" to terminal (20).
- 4. SWITCH TERMINAL - Green wire through cable "A" to terminal (40).
- 5. SWITCH TERMINAL - Black wire to junction terminal (6).
- 6. JUNCTION TERMINAL - Black wire through cable "C" to terminal (24); black wire to oil pressure signal light (7); black wire to generator light (34); black wire to switch terminal (5); black wire through cable "A" to terminal (11).
- 7. JUNCTION TERMINAL - Yellow wire through cable "A" to terminal (12); green wire to oil signal light (24).
- 8. SPEEDOMETER LIGHT - Green wire to switch terminal (3).
- 9. TERMINAL - Green wire through cable "C" to switch terminal (2); red wire with black tracer through cable "D" to head lamp toggle switch (18).
- 10. TERMINAL -- Red wire through cable "C" to switch terminal (1). This is a live terminal and can be used for accessory lamps, etc. independent of ignition-light switch.
- 11. TERMINAL - Not used with standard wiring.
- 12. TERMINAL - Not used with standard wiring.
- 13. CUT OUT RELAY - Red wire from relay terminal marked "BAT" through cable "B" to switch terminal (1); black wire from junction terminal (44) through cable "B" to relay; green wire from generator "relay" terminal (23) through cable "B" to relay.
- 14. TAIL AND STOP LAMP - Red wire through loom "J" and loom "G" to terminal (43); green wire through loom "J" and loom "G" to terminal (40).
- 15. BATTERY POSITIVE TERMINAL - (left side) - Red wire through loom "G" to terminal (38).
- 16. BATTERY NEGATIVE TERMINAL - (right side) - Black wire to ground terminal on frame.
- 17. OIL PRESSURE SIGNAL SWITCH - Green wire through cable "F" to terminal (43).
- 18. HANDLEBAR HEAD LAMP SWITCH - Black wire with red tracer through cable "D" to terminal (21); red wire with yellow tracer through cable "D" to terminal (22); red wire with black tracer through cable "D" to terminal (9).
- 19. HORN SWITCH - Black wire to terminal (25).
- 20. TERMINAL - Yellow wire through cable "C" to switch terminal (3). Used only with parking lamps.
- 21. TERMINAL - Black wire with red tracer through cable "D" to head lamp switch (18); black wire through loom "H" to head lamp (1).
- 22. TERMINAL - Red wire with yellow tracer through cable "D" to head lamp switch (18); red wire through loom "H" to head lamp (1).
- 23. TERMINAL - Not used with standard wiring. See wiring diagram showing speedometer head lock.
- 24. TERMINAL - Black wire through cable "E" to junction terminal (6); red wire through cable "E" to horn (26).
- 25. TERMINAL - Green wire through cable "E" to horn (26); black wire to horn switch.
- 26. IGNITION CIRCUIT BREAKER - Black wire to coil (35) rear terminal.
- 27. STOP LAMP SWITCH - Red wire through cable "F" to terminal (43); black wire through cable "F" to terminal (41).
- 28. GENERATOR SIGNAL LIGHT - (marked "GEN") Black wire (under panel base) to junction terminal (5); green wire (under panel base) to junction terminal (44)

KEY TO COLOR CODE			
(R) - RED	(RB) - RED WITH BLACK TRACER	(G) - GREEN	(GR) - BLACK WITH RED TRACER
(B) - BLACK	(RY) - RED WITH YELLOW TRACER	(Y) - YELLOW	

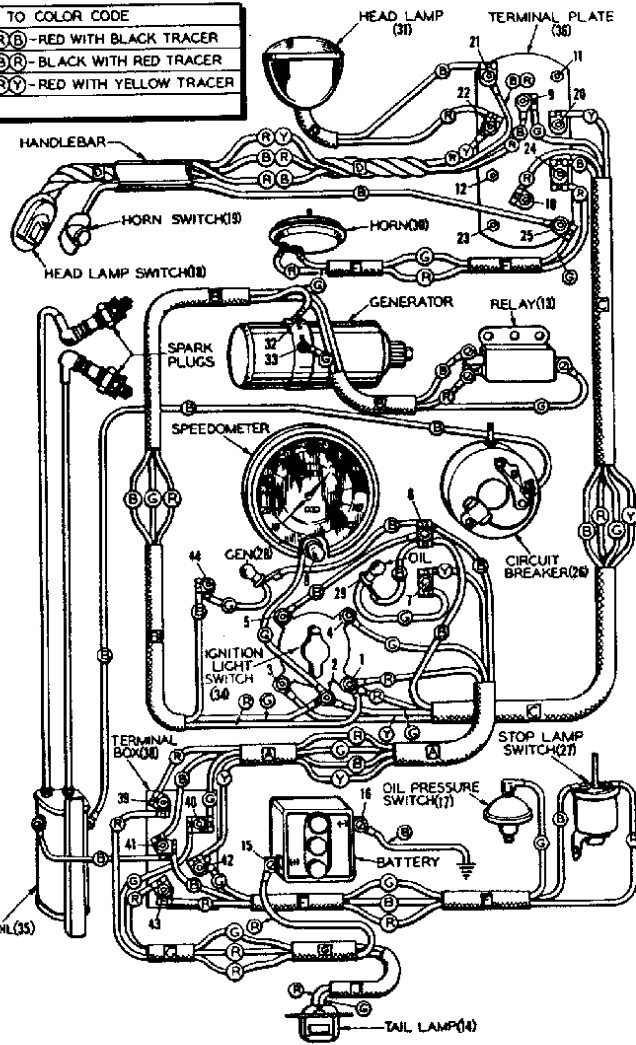

(Standard Equipped Motorcycle)  
1949 - 54

- 28. OIL PRESSURE SIGNAL LIGHT - (marked "OIL") Black wire (under panel base) to junction terminal (6); green wire (under panel base) to junction terminal (7).
- 29. HORN - Red wire through cable "E" to terminal (24); green wire through cable "E" to terminal (25).
- 30. HORN SWITCH - Red wire through loom "H" to terminal (22); black wire through loom "H" to terminal (21).
- 31. GENERATOR "SWITCH" TERMINAL - Green wire through cable "B" to switch terminal (3).
- 32. GENERATOR "RELAY" TERMINAL - Green wire through cable "B" to relay (13).
- 33. IGNITION LIGHT SWITCH - (top view) Switch position for off, ignition only, ignition and parking lights and parking lights are shown in Figure 4. Switch can be locked in off and park positions only, using head lock key.
- 34. IGNITION COIL - Black wire to terminal (41); black wire to circuit breaker (26).
- 35. TERMINAL PLATE - Mounted on fork.
- 36. TERMINAL BOX - Mounted on frame behind ignition coil.
- 37. TERMINAL - Upper left terminal of terminal box. Red wire through cable "A" to switch terminal (1); red wire through loom "G" to battery positive terminal (15).
- 38. TERMINAL - Upper right terminal of terminal box. Green wire through cable "A" to switch terminal (4); green wire through loom "G" to tail and stop lamp (14).
- 39. TERMINAL - Center left terminal of terminal box. Black wire through cable "A" to junction terminal (6); black wire through cable "F" to stop lamp switch (27); black wire to front coil terminal.
- 40. TERMINAL - Lower right terminal of terminal box. Yellow wire through cable "A" to junction terminal (1); green wire through cable "F" to oil pressure signal switch (17).
- 41. TERMINAL - Lower left terminal of terminal box. Red wire through loom "G" and "J" to tail and stop lamp (14); red wire through cable "F" to stop lamp switch (27).
- 42. JUNCTION TERMINAL - Green wire (under panel base) to generator signal light (28); black wire through cable "B" to relay (13).

NOTE - Side-car tail and stop lamps. In side-car or package truck service, if the side-car or package truck is equipped with a tail and stop lamp, the green wire of the lamp cable is connected in terminal No. 40 and red wire to terminal No. 43 on terminal box (36) behind ignition coil.

## 1955 - 57

### KEY FOR WIRING DIAGRAM (STANDARD)

- A. FOUR WIRE CABLE - Red, green, black and yellow wires from switch and instrument panel base terminals #1, #4, #6, and #7. Right front cable in panel base to terminal box behind ignition coil.
- B. THREE WIRE CABLE - Red, green, and black wires from switch and instrument panel base terminals #1, #2 and #44. Left cable in panel base to generator and cut out relay.
- C. FOUR WIRE CABLE - Red, green, yellow and black wires from switch and instrument panel base terminals #5, #2, #3 and #46.
- D. HANDLEBAR (loose wires) - Red wire with black tracer, black wire with red tracer and red wire with yellow tracer from head lamp switch on handlebar to terminal plate terminals #9, #21 and #22. Black wire from horn switch to terminal plate terminal #24. Green wire from horn switch to ground terminal plate top mounting screw.
- E. TWO WIRE CABLE - Red and green wires from horn to switch terminal #1 and to terminal #46.
- F. THREE WIRE CABLE - Black, green and red wires from terminal box, terminals #41, #42, #43 to oil pressure switch and stop lamp switch.
- G. Loom (three wires) - Red, green and red wires from terminal box terminals #39, #40 and #43.
- H. LOOM (two wires) - Black with red tracer and red wires from terminal plate terminals #21 and #22 to headlamp.
- J. LOOM (two wires) - Red and green wires, continuation from 3 wire loom (G) to tail lamp.
1. SWITCH TERMINAL - Red wire through cable "A" to terminal #39, red wire through cable "B" to relay (13); red wire through cable "E" to horn (30).
  2. SWITCH TERMINAL - Green wire through cable "C" to terminal #9; green wire through cable "B" to generator "switch" terminal #32; green wire to speedometer light (8).
  3. SWITCH TERMINAL - Yellow wire through cable "C" to terminal #20.
  4. SWITCH TERMINAL - Green wire through cable "A" to terminal #40.
  5. SWITCH TERMINAL - Black wire to junction terminal #6; red wire through cable "C" to terminal #10.
  6. JUNCTION TERMINAL - Black wire to oil signal light (29); black wire to generator signal light (28); black wire to switch terminal #5; black wire through cable "A" to terminal #41.
  7. JUNCTION TERMINAL - Yellow wire through cable "A" to terminal #42; green wire to oil signal light (29).
  8. SPEEDOMETER LIGHT - Green wire to switch terminal #2.
  9. TERMINAL - Green wire through cable "C" to switch terminal #2; red wire with black tracer through "D" to headlamp toggle switch (18).
  10. TERMINAL - Red wire through cable "C" to switch terminal #5. This is a live terminal and can be used for accessory lamps, etc.
  11. TERMINAL - Not used with standard wiring.
  12. TERMINAL - Not used with standard wiring.
  13. CUT OUT RELAY - Red wire from relay terminal marked "BAT" through cable "B" to switch terminal #1; black wire from junction terminal #44 through cable "B" to relay; green wire from generator "relay" terminal #33 through cable "B" to relay.
  14. TAIL AND STOP LAMP - Red wire through loom "J" and loom "G" to terminal #43; green wire through loom "J" and loom "C" to terminal #40.
  15. BATTERY POSITIVE TERMINAL (left side) - Red wire through loom "G" to terminal #39.
  16. BATTERY NEGATIVE TERMINAL (right side) - Black wire to ground terminal on frame.
  17. OIL PRESSURE SIGNAL SWITCH - Green wire through cable "F" to terminal #42.
  18. HANDLEBAR HEAD LAMP SWITCH - Black wire with red tracer through "D" to terminal #21; red wire with yellow tracer through "D" to terminal #22; red wire with black tracer through "D" to terminal #9.
  19. HORN SWITCH - Black wire to terminal #24; green wire to ground terminal plate top mounting screw.
  20. TERMINAL - Yellow wire through cable "C" to switch terminal #3; used only with parking lamps.
  21. TERMINAL - Black wire with red tracer through "D" to headlamp switch (18); black wire through loom "H" to headlamp (31).
  22. TERMINAL - Red wire with yellow tracer through "D" to headlamp switch (18); red wire through loom "H" to headlamp (31).
  23. TERMINAL - Not used with standard wiring.
  24. TERMINAL - Black wire through cable "C" to junction terminal #46; black wire to horn switch (19).
  25. TERMINAL - Not used with standard wiring.
  26. IGNITION CIRCUIT BREAKER - Black wire to coil (35) rear terminal.
  27. STOP LAMP SWITCH - Red wire through cable "F" to terminal #43; black wire through cable "F" to terminal #41.
  28. GENERATOR SIGNAL LIGHT (marked "GEN") - Black wire (under panel base) to junction terminal #6; green wire (under panel base) to junction terminal #44.
  29. OIL SIGNAL LIGHT (marked "OIL") - Black wire (under panel base) to junction terminal #6; green wire (under panel base) to junction terminal #7.
  30. HORN - Red wire through cable "E" to switch terminal #1; green wire through cable "E" to terminal #46.
  31. HEADLAMP - Red wire through loom "H" to terminal #22; black wire with red tracer through loom "H" to terminal #21.
  32. GENERATOR "SWITCH" TERMINAL - Green wire through cable "B" to switch terminal #2.
  33. GENERATOR "RELAY" TERMINAL - Green wire through cable "B" to relay (13).
  34. IGNITION-LIGHT SWITCH (top view) - Switch position for off, ignition only, ignition and running lights and parking lights are shown in Figure 4. Switch can be locked in off and park positions only, using head lock key.
  35. IGNITION COIL - Black wire to terminal #41; black wire to circuit breaker (26).
  36. TERMINAL PLATE - Mounted on fork.
  38. TERMINAL BOX - Mounted on frame behind ignition coil.
  39. TERMINAL - Upper left terminal of terminal box. Red wire through cable "A" to switch terminal #1; red wire through loom "G" to battery positive terminal #15.
  40. TERMINAL - Upper right terminal of terminal box. Green wire through cable "A" to switch terminal #4; green wire through loom "G" to tail and stop lamp (14).
  41. TERMINAL - Center left terminal of terminal box. Black wire through cable "A" to junction terminal #6; black wire through cable "F" to stop lamp switch (27); black wire to front coil terminal.
  42. TERMINAL - Lower right terminal of terminal box. Yellow wire through cable "A" to junction terminal #7; green wire through cable "F" to oil signal switch (17).
  43. TERMINAL - Lower left terminal of terminal box. Red wire through loom "G" and "J" to tail and stop lamp (14); red wire through cable "F" to stop lamp switch (27).
  44. JUNCTION TERMINAL - Green wire (under panel base) to generator signal light (28); black wire through cable "B" to relay (13).
  45. HEADLAMP BRACKET - Black wire to ground terminal plate top mounting screw.
  46. JUNCTION TERMINAL - Forward left side instrument panel green wire through cable "E" to horn (30); black wire through cable "C" to terminal #24.

#### NOTE

Sidecar tail and stop lamps. If the sidecar or package truck is equipped with a tail and stop lamp, the green wire of the lamp cable is connected to terminal #40 and red wire to terminal #43 on terminal box (38) behind ignition coil.

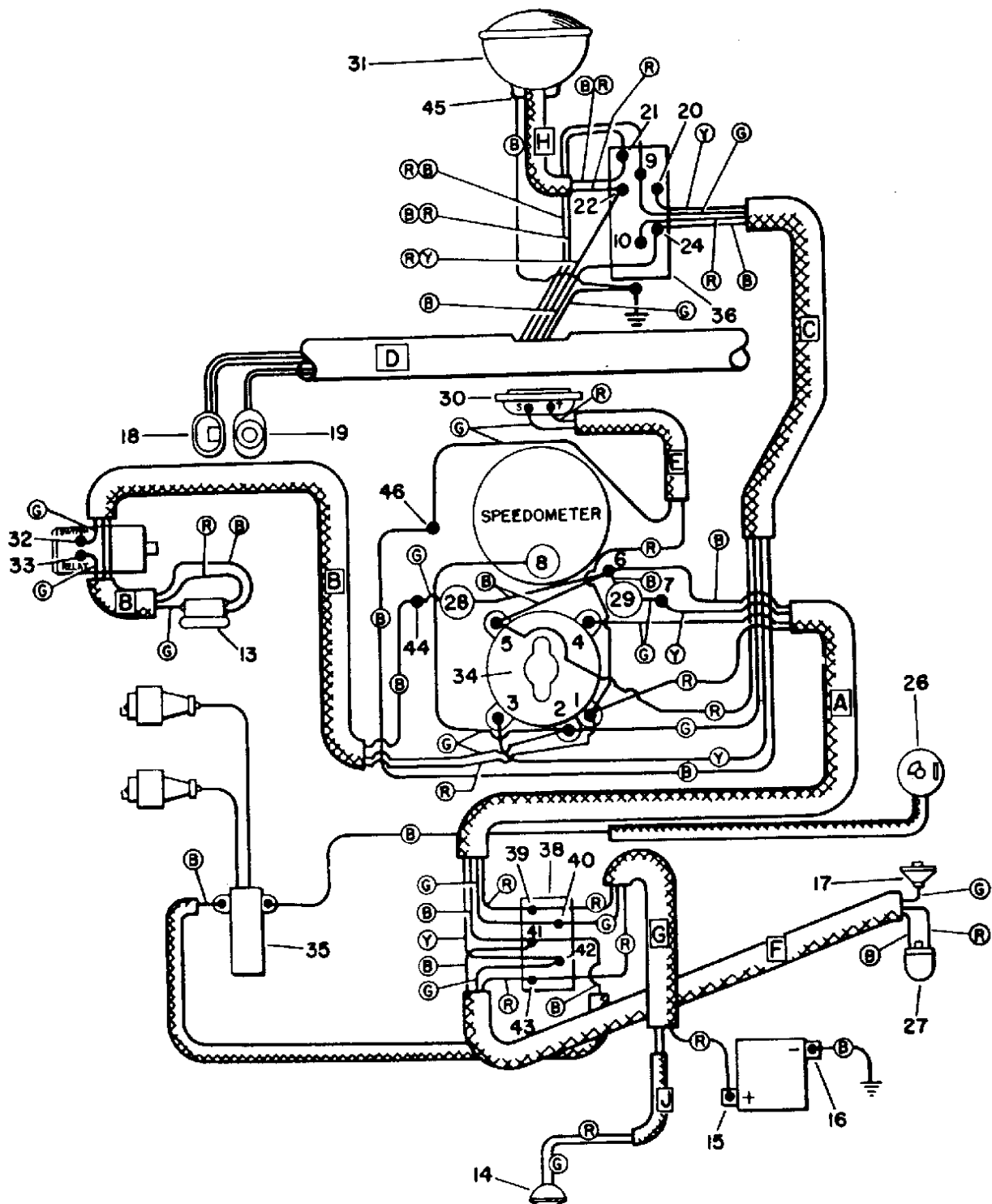

KEY TO COLOR CODE	
(R) RED	(R)(B) RED WITH BLACK TRACER
(G) GREEN	(B)(R) BLACK WITH RED TRACER
(B) BLACK	(R)(Y) RED WITH YELLOW TRACER
(Y) YELLOW	

Wiring Diagram (Standard)

1955-57

## KEY FOR WIRING DIAGRAM (RADIO-SPECIAL)

- A. FOUR WIRE CABLE - Red, green, black and yellow wires from switch and instrument panel base terminals #1, #4, #6 and #7. Right front cable in panel base to terminal box behind ignition coil.
- B. LOOM (one wire) - Green wire from generator signal light (28) (under panel) to "REG" terminal on generator.
- C. FOUR WIRE CABLE - Red, green, yellow and black wires from switch and instrument panel base terminals #1, #2, #3 and #46. Right rear cable in panel base to terminal plate on fork.
- D. HANDLEBAR (loose wires) - Red wire with black tracer, black wire with red tracer and red wire with yellow tracer from headlamp switch on handlebar to terminal plate terminals #9, #21, and #22. Black wire from horn switch to terminal plate terminal #24. Green wire from horn switch to ground terminal plate top mounting screw. Black wire (right handlebar) from speedometer hand lock switch (47) to terminal plate terminal #23.
- E. TWO WIRE CABLE - Red and green wires from horn to switch terminal #1 and terminal #46.
- F. THREE WIRE CABLE - Black, green and red wires from terminal box, terminals #41, #42 and #43 to oil switch and stop lamp switch.
- G. LOOM (two wires) - Red and green from terminal box terminals #43 and #40 to tail lamp.
- H. LOOM (two wires) - Black and red wires from terminal plate terminals #21 and #22 to headlamp.
- J. LOOM (one wire) - Red wire from terminal box terminal #39 (back of box) to positive battery terminal.
- K. LOOM (one wire) - Red wire from terminal box terminal #39 (back of box) to "BAT." Terminal of current and voltage regulator.
- L. LOOM (one wire) - Black wire from positive battery terminal to radio.
- M. LOOM (two wire armored cable) - Red and green wire from generator terminals marked "REG" and "(F)." Armored covering of cable grounded at both ends to generator and current and voltage regulator.
1. SWITCH TERMINAL - Red wire through cable "A" to terminal #39; red wire through cable "C" to terminal #10; red wire through cable "E" to horn.
2. SWITCH TERMINAL - Green wire through cable "C" to terminal #9; green wire to speedometer light (8).
3. SWITCH TERMINAL - Yellow wire through cable "C" to terminal #20.
4. SWITCH TERMINAL - Green wire through cable "A" to terminal #40.
5. SWITCH TERMINAL - Black wire to junction terminal #6.
6. JUNCTION TERMINAL - Black wire to oil signal light (29); black wire to generator signal light (28); black wire to switch terminal #5; black wire through cable "A" to terminal #41; black wire to speedometer hand lock (48).
7. JUNCTION TERMINAL - Yellow wire through cable "A" to terminal #42; green wire to oil signal light (29).
8. SPEEDOMETER LIGHT - Green wire to switch terminal #2.
9. TERMINAL - Green wire through cable "C" to switch terminal #2; red wire with black tracer through "D" to headlamp toggle switch (18).
10. TERMINAL - Red wire through cable "C" to switch terminal #1. This is a live terminal and can be used for accessory lamps, etc. independent of ignition-light switch.
11. TERMINAL - Not used with radio wiring.
12. TERMINAL - Not used with radio wiring.
13. CURRENT AND VOLTAGE REGULATOR - Green wire through loom "M" to generator "(F)" terminal; red wire through loom "M" to generator "REG" terminal.
14. TAIL AND STOP LAMP - Red wire through loom "G" to terminal #43; green wire through loom "G" to terminal #40.
15. BATTERY POSITIVE TERMINAL - Black wire through loom "L" to radio. Red wire through loom "J" to terminal #39.
16. BATTERY NEGATIVE TERMINAL - Black wire to ground terminal on frame.
17. OIL SIGNAL SWITCH - Green wire through cable "F" to terminal #42.
18. HANDLEBAR HEADLAMP SWITCH - Black wire with red tracer through cable "D" to terminal #21; red wire with yellow tracer through cable "D" to terminal #22; red wire with black tracer through cable "D" to terminal #9.
19. HORN SWITCH - Black wire to terminal #24; green wire to ground terminal plate top mounting screw.
20. TERMINAL - Yellow wire through cable "C" to switch terminal #3. Used only with parking lamps.
21. TERMINAL - Black wire with red tracer through "D" to headlamp switch (18); black wire through loom "H" to headlamp (31).
22. TERMINAL - Red wire with yellow tracer through "D" to head lamp switch (18); red wire through loom "H" to head lamp (31).
23. TERMINAL - Black wire (loose) to speedometer hand lock (48); black wire (loose) to handlebar speedometer hand lock switch (47) (right side handlebar).
24. TERMINAL - Black wire (loose) to horn switch; black wire through cable "C" to terminal #46.
25. TERMINAL - Not used with radio wiring.
26. IGNITION CIRCUIT BREAKER - Black wire to coil (35) rear terminal.
27. STOP LAMP SWITCH - Red wire through cable "F" to terminal #43; black wire through cable "F" to terminal #41.
28. GENERATOR SIGNAL LIGHT (marked "GEN") - Black wire (under panel base) to junction terminal #6; green wire (under panel base) to generator "REG" terminal.
29. OIL SIGNAL LIGHT (marked "OIL") - Black wire (under panel base) to junction terminal #6; green wire (under panel base) to junction terminal #7.
30. HORN - Red wire through cable "E" to switch terminal #1; green wire through cable "E" to junction terminal #46.
31. HEAD LAMP - Red wire through loom "H" to terminal #22; black wire through loom "H" to terminal #21.
32. GENERATOR "F" TERMINAL - Green wire through loom "M" to terminal "F" of current and voltage regulator.
33. GENERATOR "REG" TERMINAL - Red wire through loom "M" to terminal "GEN" of current and voltage regulator.
34. IGNITION-LIGHT SWITCH (top view) - Switch position for off, ignition only, ignition and running lights and parking lights are shown in Figure 4. Switch can be locked in off and park positions only, using head lock key.
35. IGNITION COIL - Black wire to terminal #41; black wire to circuit breaker (26).
36. TERMINAL PLATE - Mounted on fork.
38. TERMINAL BOX - Mounted on frame behind ignition coil.
39. TERMINAL (Upper left terminal of terminal box) - Red wire through cable "A" to switch terminal #1; red wire through loom "J" to battery positive terminal #15; red wire through loom "K" to "BAT" terminal of current and voltage regulator.
40. TERMINAL (Upper right terminal of terminal box) - Green wire through cable "A" to switch terminal #4; green wire through loom "G" to tail and stop lamp (14).
41. TERMINAL (Center left terminal of terminal box) - Black wire through cable "A" to junction terminal #5; black wire through cable "F" to stop lamp switch (27); black wire to front coil terminal.
42. TERMINAL (Lower right terminal of terminal box) - Yellow wire through cable "A" to junction terminal #7; green wire through cable "F" to oil signal switch (17).
43. TERMINAL (Lower left terminal of terminal box) - Red wire through loom "G" to tail and stop lamp (14); red wire through cable "F" to stop lamp switch (27).
44. JUNCTION TERMINAL - Not used with radio wiring.
45. HEAD LAMP BRACKET - Black wire to ground terminal plate top mounting screw.
46. JUNCTION TERMINAL (Forward left side instrument panel) - Green wire through cable "E" to horn (30); black wire through cable "C" to terminal #24.
47. SPEEDOMETER HAND LOCK SWITCH - Black wire through right handlebar to terminal #23.
48. SPEEDOMETER HAND LOCK - Black wire (loose) to terminal #23; black wire to junction terminal #6.

## NOTE

Sidecar tail and stop lamp. If the sidecar is equipped with a tail and stop lamp, the green wire of the lamp cable is connected to terminal #40 and the red wire to terminal #43 on terminal box (38) behind ignition coil.

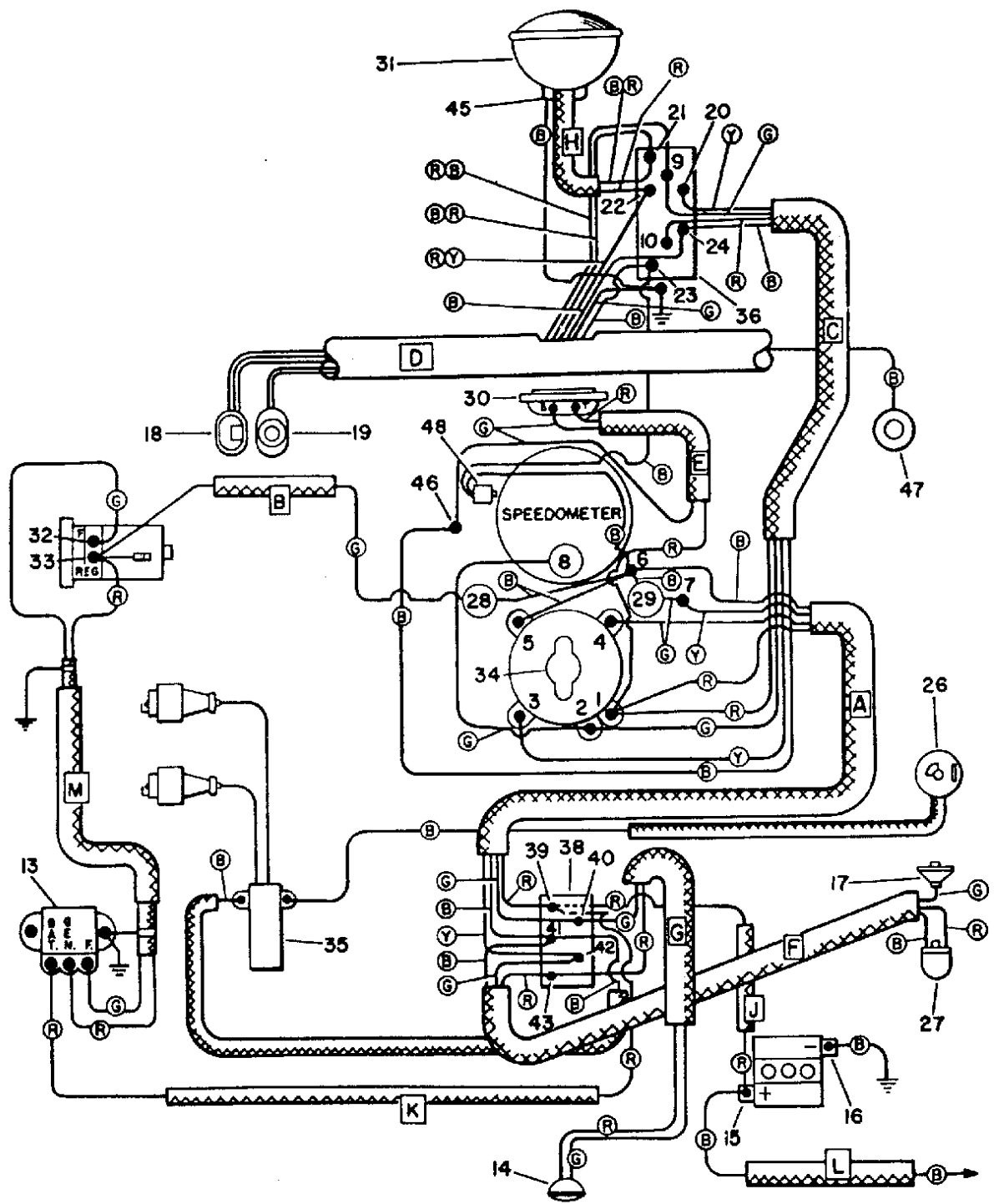

KEY TO COLOR CODE	
(R) RED	(RB) RED WITH BLACK TRACER
(G) GREEN	(BR) BLACK WITH RED TRACER
(B) BLACK	(RY) RED WITH YELLOW TRACER
(Y) YELLOW	

Wiring Diagram (Radio-Special)



## SWITCHES

### IGNITION-LIGHT SWITCH

The switch located in the center of the instrument panel below the "GEN" and "OIL" indicator lamps is a combination ignition-light switch. It has three positions plus a center-off position. One notch counterclockwise illuminates parking lights only. The first notch or click clockwise from the center-off position is ignition only while the second click is running lights and ignition.

It is not necessary to keep the key inserted in the lock to operate the switch after it has been unlocked. The switch can be locked only in the "off" and "parking lights" position.

#### DISASSEMBLING IGNITION LIGHT SWITCH

On Glide and Servi-Car Models remove instrument panel cover by prying out side-cover clip located at trip mileage set knob and turning out mounting base center screw located in the center of instrument panel below speedometer. On Model 165 remove switch bezel to expose switch.

Disconnect all wires connected to switch terminals and remove four switch mounting screws.

See Fig. 5C-1. All directions for disassembly apply with switch in an inverted position. Switch must be in "off" position and unlocked.

Grasp end of roller contact retainer with pliers and

simultaneously move it upward and away from roller contact (1). Lift off roller contact and switch mounting plate assembly (2). Notice that this plate is positioned with the three-terminal side away from lock cover hinge.

Reinforcing plate (3) with contact bar holder (4) and roller contact retainer (5) can be removed from switch cover by slipping part assembly sideways until one set of tabs clears slot in switch cover, then lifting and sliding assembly the opposite direction to clear other tab.

Switch base (7) and lock plate (6) can be removed from switch cover. Note that narrow end of elongated hole in lock, and lug on switch lock (8) which fits into hole in lock plate, are toward lock cover hinge.

Lock assembly (8 and 9) can now be lifted out of switch cover (10). Avoid separating switch cylinder from its case unless lock is faulty. On some models the lock cylinder and case are a single unit.

#### CLEANING, INSPECTION AND REPAIR

Wash all parts in cleaning solvent and dry with compressed air.

Inspect all parts, particularly roller contact and plate assembly for excessive wear of contacting brass buttons and roller surfaces. Extreme wear of these parts may allow head of roller contact retainer to short against switch lock plate. Loosened terminals on switch mounting plate may also cause a short

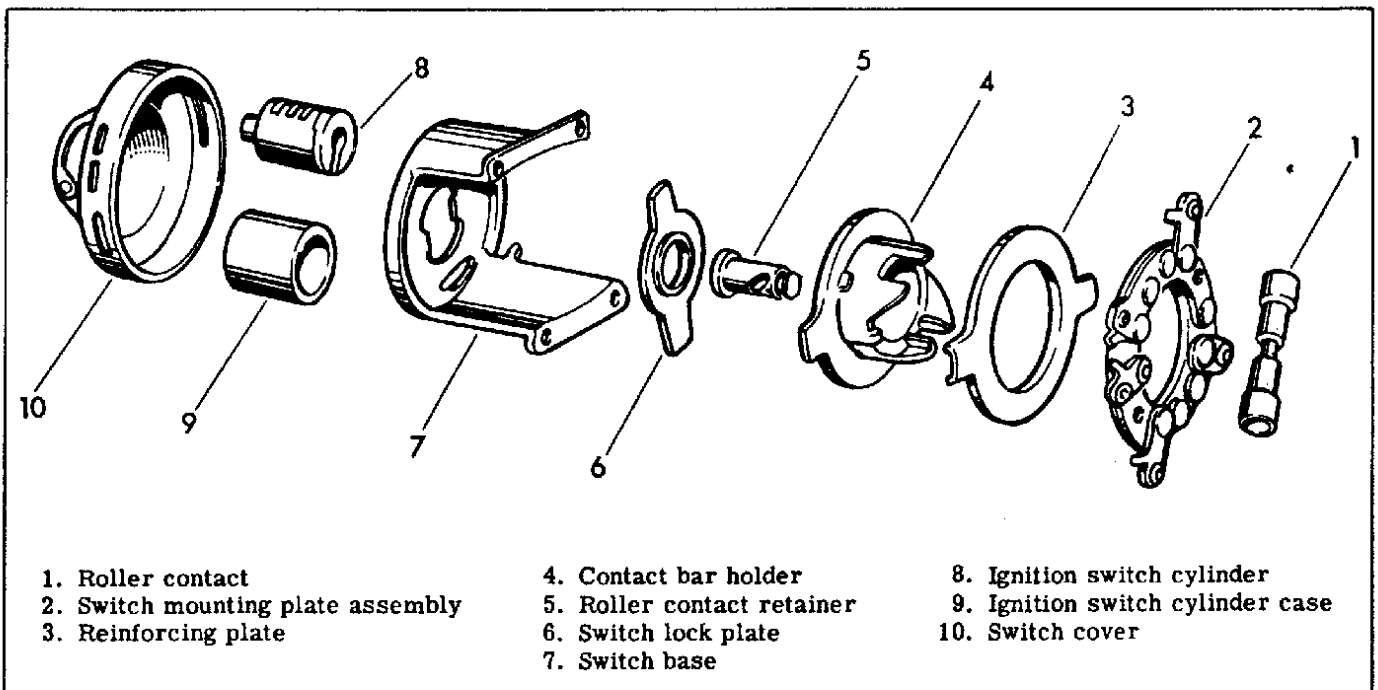

Figure 5C-1. Ignition Light Switch

or an inconsistent positive contact. Replace all worn or rusted parts.

#### ASSEMBLING IGNITION LIGHT SWITCH

Apply a light coat of grease to head of roller contact retainer, lock plate, roller contact and contact buttons on switch mounting plate.

Assemble parts in reverse order of disassembly. If lock cylinder had to be removed from case for repair or replacement, it must be replaced in correct position or switch cannot be locked. To reassemble correctly, insert lock cylinder into housing with tumblers in any one of the four registers. While pressing cylinder into housing with fingertip, insert key and turn clockwise as far as possible. Remove key and complete assembly.

#### BUTTON SWITCH

This type switch is used for momentary closing of circuits to horn, magneto or starting motor and is located on handlebar. Terminal has either one or two wires. See Figure 5C-1A.

To disassemble the switch, remove terminal assembly (1) from housing (2) with a screwdriver. Remove spring (3), contact plate (4), and button (5) from the housing (2).

To replace the switch wires, unsolder the old wires and solder new wires onto the terminal assembly. Assemble in reverse order of disassembly.

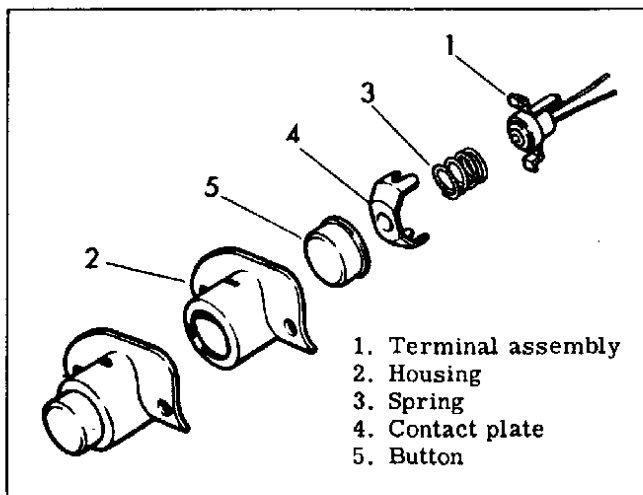

Figure 5C-1A. Button Switch - Exploded View

#### HEADLAMP DIMMER AND HORN SWITCH

This type switch has the headlamp dimmer switch and horn button combined in one unit located on the handlebar. High and low beams are operated with flip switch. Button operates horn. See Figure 5C-1B.

To disassemble switch, remove clamping screws (1) and separate parts of switch: cover (2), switch (3), and base (4). Remove wires (5) from switch by loosening terminal screws (6).

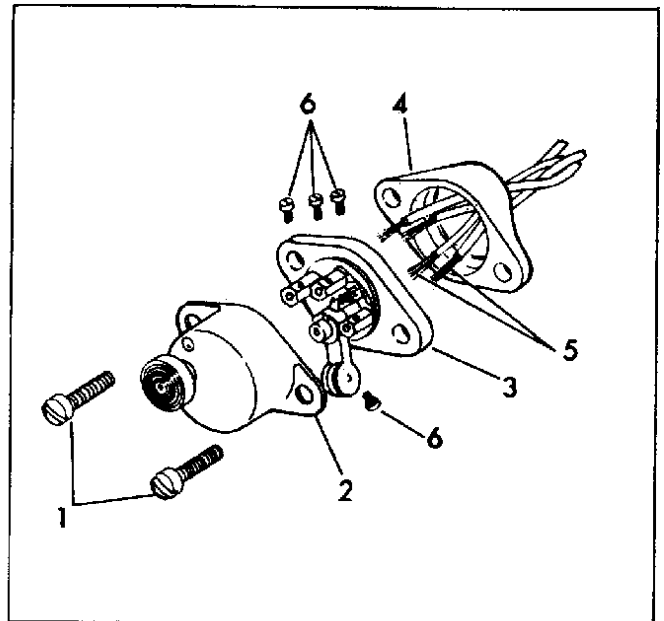
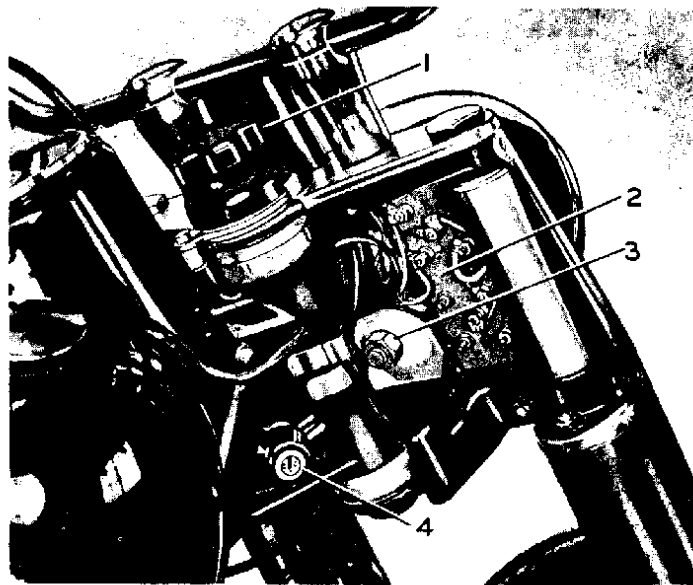

Figure 5C-1B. Dimmer and Horn Switch Exploded View

Check switch for wear, and replace switch if it will not stay in high or low beam position. Check spring tension on horn button.

Replace worn or broken parts with a new switch or base. Clean terminals and reassemble in reverse order. Be careful not to over-tighten clamp screws or plastic body may crack.



1. Steering Damper Adjusting Knob  
2. Terminal Plate  
3. Headlamp Clamp Nut  
4. Headlock

## Headlamp

The headlamp is a sealed-beam type, specially designed and made for Harley-Davidson motorcycles. When replacement is required, use only the prescribed sealed-beam unit. Do not attempt to use an automobile sealed-beam unit because the current requirements for a motorcycle are much less than for an automobile and damage to battery or generator will result. If either filament burns out, or the lens breaks, the entire unit must be replaced. Do not attempt to repair a defective sealed-beam unit because when the seal is broken the reflector tarnishes and poor light and road visibility result.

### GLIDE

Loosen door screw enough to remove headlamp door. Remove three retaining ring screws and retaining ring.

**NOTE:** Late models may have spring hooked into retaining ring hole - unhook spring to free retaining ring.

The sealed-beam unit is now free from the headlamp body, and connector block can be removed from the unit by pulling connector block from the unit prongs.

Assembly is the reverse order of disassembly. Make sure connector block contacts are clean to ensure good electrical contact.

### BEAM ADJUSTMENT

To get the greatest efficiency from the headlamp and to meet the requirements of the law, correctly adjust headlamp beam according to the following instructions.

Draw a horizontal line on a wall or screen exactly the same height as the center of the headlamp to be checked and adjusted. Then, position the motorcycle on a level surface with headlamp approximately 25 feet away from the test pattern. Have a rider sit on the motorcycle to simulate actual running conditions. Be sure tires are correctly inflated. Aim the headlamp directly at the screen and turn on the light switch. Set beam selector switch on the high beam position, and check beam for height and direction. The top of the main beam of light should register even with, but no higher than the horizontal line of the test pattern.



1. Door Screw  
2. Head Lamp Door  
3. Retaining Ring Screws  
4. Retaining Ring  
5. Cycle Beam Sealed Unit  
6. Connector Block

### REPLACING HEAD LAMP-CYCLE BEAM SEALED UNIT

If either filament burns out, or the lens breaks, the entire cycle-beam unit must be discarded and a new unit installed.

To install a new unit loosen door screw (1) enough to remove head lamp door (2). Remove the three retaining-ring screws (3) and retaining ring (4). The cycle-beam unit (5) is now free from the head lamp body, and the connector block (6) can now be removed from the unit by pulling connector block from the unit prongs.

Install the new unit by reversing above operations. Make sure prongs on unit are clean, to assure good contact with connector block.

At the same time, turn the headlamp right or left to direct the beam of light straight ahead. Tighten the clamp nut after the lamp is correctly adjusted and install remaining fork parts.

# 32 E 3 BRUSH GENERATOR

## Generator

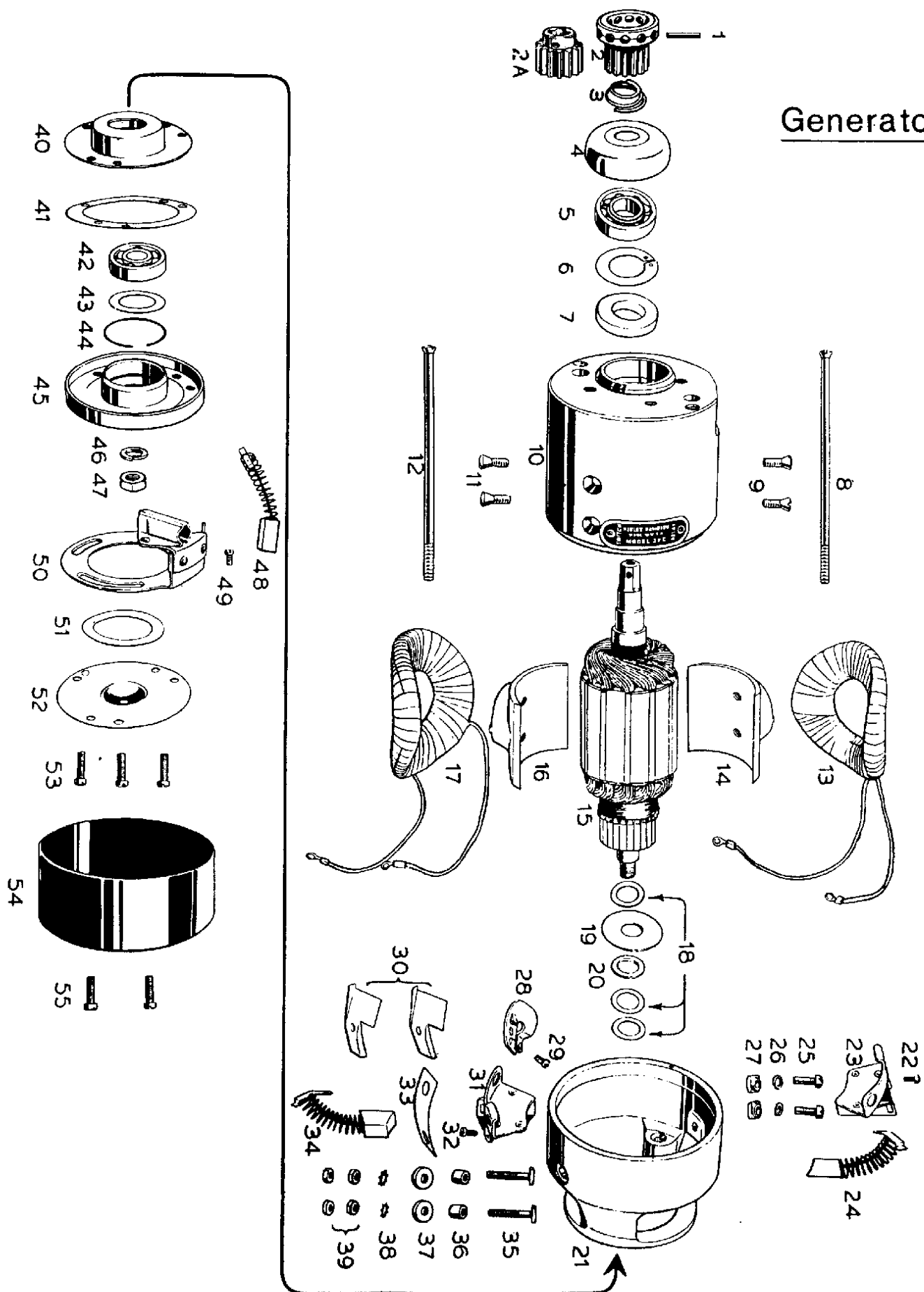

ILLUS. 79  
STANDARD GENERATOR DISASSEMBLED

## STANDARD GENERATOR ASSEMBLY

(Item Numbers Refer to Illus. 79)

ITEM	NUMBER USED	PART NUMBER	NAME
1	1	327	Drive Gear Pin
2	1	31071-37	Drive Gear (Side Valve Models)
2A	1	31071-30	Drive Gear (O.H.V. Models)
3	1	31040-31	Drive End Spring
4	1	31035-31	Oil Deflector
5	1	31009-30	Drive End Bearing (large)
6	1	31045-31	Spring Ring
7	1	31041-31	Felt Oil Retainer—See paragraph 11 under "Disassembling Generator," Page 99
8	2	30012-32	Frame End Screw (same as Item 12)
9	4	30280-18	Pole Shoe Screw (same as Item 11)
10	1	30090-32	Frame
11	See Item 9		.....
12	See Item 8		.....
13	1	30202-32	Shunt Field Coil (White identification mark)
14	2	30271-30	Pole Shoe (same as Item 16)
15	1	30851-32	Armature
16	See Item 14		.....
17	1	30206-32	Regulating Field Coil (Orange identification mark)
18	3	6453	Armature Steel Spacer (.025")
19	1	30985-29	Armature Bakelite Washer
20	1	6551	Armature Steel Spacer (.072")
21	1	30132-32	Frame End
22	4	993	Terminal Screw (same as Items 29, 32 and 49)
23	2	30351-32	Brush Holder (same as Item 31)
24	2	30450-32	Brush (same as Item 34)
25	2	1202	Brush Holder Bolt
26	2	7021	Lock Washer
27	2	30367-32	Nut
28	1	30231-32	Shunt Field Coil Terminal
29	See Item 22		.....
30	2	20228-32	Shunt Field Coil Terminal Insulation
31	See Item 23		.....
32	See Item 22		.....
33	1	30365-32	Positive Brush Holder Insulation
34	See Item 24		.....
35	2	30460-32	External Terminal Bolt
36	2	30463-32	Terminal Bolt Bushing
37	2	6186	Insulating Washer
38	2	7220	Lock Washer
39	4	7634	Nut
40	1	31020-30	Grease Retainer, Inner
41	1	30138-30	Gasket
42	1	31009-18	Commutator End Bearing
43	1	30890-18	Spacing Shim (.020")
44	1	31017-29	Spring Ring (1 $\frac{1}{16}$ " diameter)
45	1	31010-48	Bearing Housing
46	1	7065	Lock Washer
47	1	7789	Armature Shaft Nut
48	1	30427-26	Third (regulating) Brush (small)
49	See Item 22		.....
50	1	30385-32	Third (regulating) Brush Holder
51	1	31015-30	Gasket
52	1	31022-33	Grease Retainer, Outer
53	5	1210	Screw (same as Item 55)
54	1	30137-32	End Cover
55	See Item 53		.....

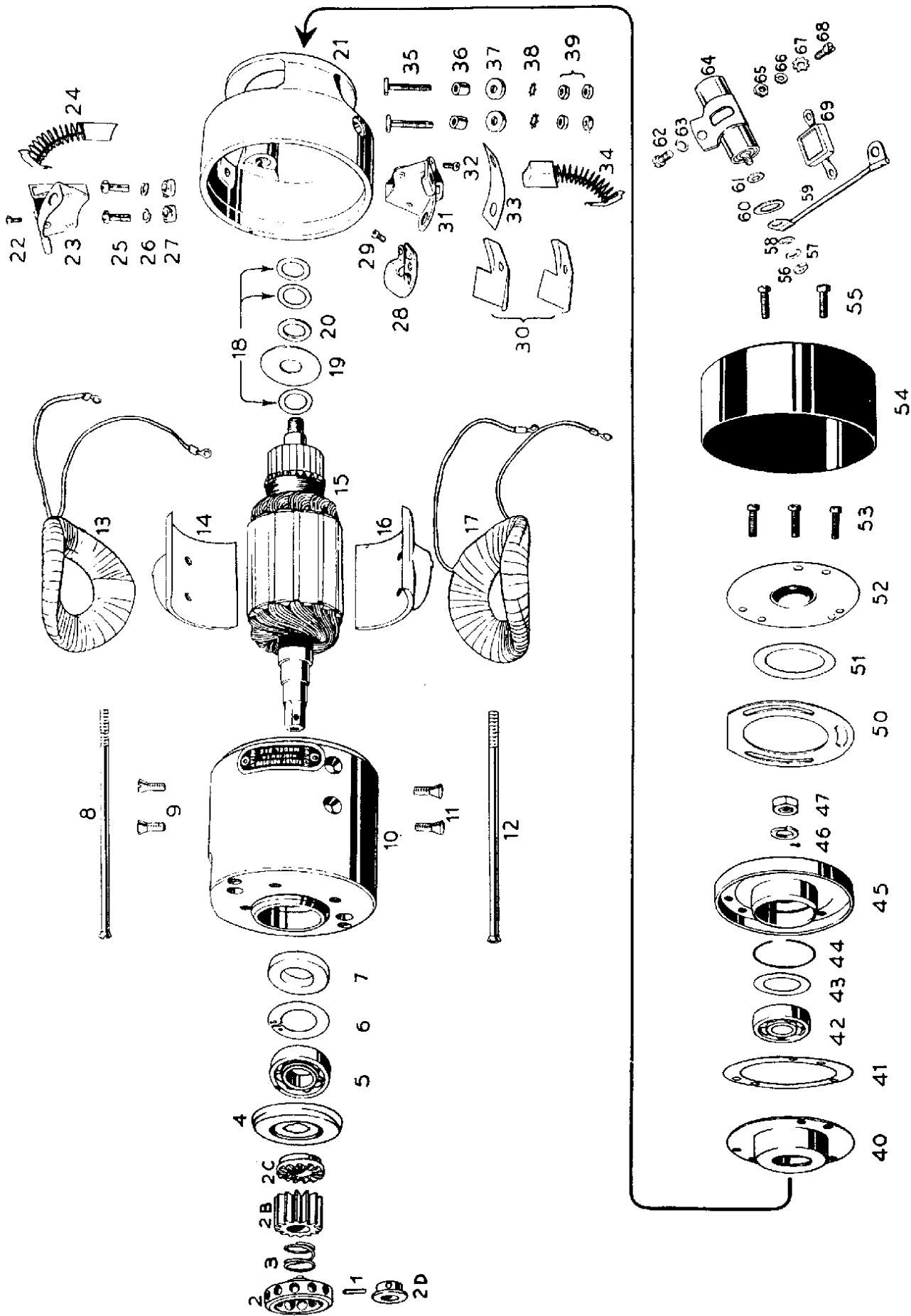

ILLUS. 80  
RADIO (TWO BRUSH) GENERATOR DISASSEMBLED

## RADIO (TWO BRUSH) GENERATOR ASSEMBLY

(Item Numbers Refer to Illus. 80)

ITEM	NUMBER USED	PART NUMBER	NAME
1	1		Drive Gear Pin
2	1		Oil Centrifuge (Side Valve Models)
2B	1		Drive Gear
2C	1		Generator Clutch
2D	1		Clutch Spring Collar (O.H.V. Models)
3	1		Drive End Spring
4	1		Oil Deflector
5	1		Drive End Bearing (large)
6	1		Spring Ring
7	1		Felt Oil Retainer
8	2		Frame End Screw (same as Item 12)
9	4		Pole Shoe Screw (same as Item 11)
10	1		Frame
11	See Item 9		
12	See Item 8		
13	1		Shunt Field Coil (White identification mark)
14	2		Pole Shoe (same as Item 16)
15	1		Armature
16	See Item 14		
17	1		Regulating Field Coil (Orange identification mark)
18	3		Armature Steel Spacer (.025")
19	1		Armature Bakelite Washer
20	1		Armature Steel Spacer (.072")
21	1		Frame End
22	3		Terminal Screw (same as Items 29 and 32)
23	2		Brush Holder (same as Item 31)
24	2		Brush (same as Item 34)
25	2		Brush Holder Bolt
26	2		Lock Washer
27	2		Nut
28	1		Field Coil Terminal
29	See Item 22		
30	2		Field Coil Terminal Insulation
31	See Item 23		
32	See Item 22		
33	1		Positive Brush Holder Insulation
34	See Item 24		
35	2		External Terminal Bolt
36	2		Terminal Bolt Bushing
37	2		Insulating Washer
38	2		Shakeproof Lock Washer
39	4		Nut
40	1		Grease Retainer, Inner
41	1		Gasket
42	1		Commutator End Bearing
43	1		Spacing Shim (.020")
44	1		Spring Ring (1 $\frac{5}{16}$ " diameter)
45	1		Bearing Housing
46	1		Lock Washer
47	1		Armature Shaft Nut
50	1		Generator End Plate
51	1		Gasket
52	1		Grease Retainer, Outer
53	5		Screw (same as Item 55)
54	1		End Cover
55	See Item 53		
56	1		Nut
57	2		Plain Washer (same as Item 61)
58	1		Shakeproof Lock Washer
59	1		Condenser Wire
60	1		Insulating Washer
61	See Item 57		
62	1		Screw
63	1		Lock Washer
64	1		Condenser
65	1		Nut
66	1		Lock Washer
67	1		Shakeproof Lock Washer
68	1		Screw
69	1		Mica Capacitor, .0005 mf (used only with General Electric ultra-high-frequency receiver)

FOOTNOTE: Illus. 80 applies to radio (three brush) generator, except endplate (50).

Instead of endplate (50) Illus. 80, the following parts shown in Illus. 79 are used—third (regulating) brush holder (50), third (regulating) brush (48) and terminal screw (49).

## ELECTRICAL SYSTEM

Electrical system is a 6-volt, one wire ground return system with negative ground. Three-brush generator is regulated by the third or regulating brush and "lamp load." Lamp load regulation is accomplished by connecting "shunt" field winding in the lighting circuit. When lamps are turned "ON" this field is energized and generator output is increased to carry load of lighting equipment. Two-brush generator is regulated entirely by current and voltage regulator.

Generator models are identified as follows:

Standard Generator—Model 32E

Radio (three brush) Generator—Model 32E2

Radio (two brush) Generator—Model 32E2 and 32E2R

### When Generator Fails to Charge

When generator apparently quits charging (indicated by signal light in switch panel staying lit or battery going dead—see "Instrument Panel Signal Lights," the trouble may be of such nature that repairs can be made without removing generator. Follow procedure outlined below, step by step, until the trouble is located.

1. Remove black wire from generator signal light terminal on relay if a three brush generator, or generator signal light green wire from generator "relay" terminal if a two brush generator, and keep wire end from touching any part of motorcycle. Turn ignition switch "ON." If wire is not grounded, signal light in instrument panel will remain out—if grounded, light will go on. With engine running at fast idling speed and wire grounded, signal light in instrument panel will remain on whether or not generator is charging.

2. Test the battery and if its condition is questionable replace with fully charged battery before making further tests.

3. Remove left footboard and clutch footpedal assembly.

4. Disconnect any condensers found connected to generator "relay" terminal and generator frame end or cover. A shorted condenser will prevent generator charging. Do not as yet remove resistor from generator "relay" and "switch" terminals of a radio (three brush) generator.

5. Remove generator end cover and inspect brushes to make sure they are not worn out, broken or gummy and sticking in brush holders.

6. See that commutator is not excessively oily, dirty or gummy. See "Cleaning Commutator."

7. Make sure brush holders are not bent and possibly striking shoulder on commutator.

8. If the fault is not found through above checks, it may be in cut-out relay, current and voltage regulator if motorcycle is so equipped, or in wiring between generator and battery.

To check whether trouble is in generator, relay or current and voltage regulator, or wiring between generator and battery:

A. Connect an ammeter (two-brush generator, use at least an 0-30 ampere scale ammeter) between battery negative (right) terminal and ground.

B. Disconnect wires from generator "relay" terminal and battery positive terminal and connect a jumper wire directly between these two terminals. Also, if generator is two-brush type, disconnect wire from generator "switch" terminal and temporarily connect a short length of wire between generator "switch" terminal and ground. A convenient ground connection can be made by connecting wire to generator end with a commutator end cover screw.

### Standard and Radio (three brush) Generator:

C. Start and speed up engine and check reading of ammeter. If generator shows normal charge (see "Generator Charging Rate," trouble is in cut-out relay (see "Cut-Out Relay," or in wiring between relay and battery (see "Wiring Diagram," If standard generator shows no charge, it must be removed for further attention. If radio generator shows no charge, check resistor connected to "relay" and "switch" terminals to make sure it is not defective and grounding to generator frame end. If not grounded generator must be removed for further attention.

### Radio (two brush) Generator:

D. Start and speed up engine and check reading of ammeter. If generator shows charge of 15 amperes minimum, trouble is in cut-out relay (incorporated with current and voltage regulator), in wiring between generator "relay" terminal and regulator "GEN" terminal, in wiring between regulator "BAT" terminal and battery, in wiring between generator "switch" terminal and regulator "F" terminal (see "Wiring Diagram," or in current and voltage regulator (see "Current and Voltage Regulator," If generator shows no charge it must be removed for further attention.

REMOVE GENERATOR SCREWS



ILLUS. 81  
REMOVING GENERATOR END MOUNTING SCREWS



## Removing Generator

1. Disconnect wires from generator "switch" and "relay" terminals.

2. Remove the two long screws, through timing gear case cover, that secure end of generator against gear case (see Illus. 81).

3. Remove nut, lock washer and convex washer from end of strap that clamps generator in its cradle on crankcase (see Illus. 82).

4. *Side Valve Engine:* Lift strap high enough to permit raising generator so oil centrifuge (on end of generator gear or on armature shaft) will clear adjacent gear and allow generator to be removed from engine.

*O.H.V. Engine:* Generator has no oil centrifuge and can be pulled straight out.

5. Be sure to observe and count number of paper shims between generator and cradle. Lay these shims aside to be used again when generator is re-installed. Also note location of hole in shims for oil drain. These shims were required in original assembly to adjust driving gears for proper mesh and, if left out, gears are still likely to mesh too deeply and howl, even though they have seen considerable service.

Note: In 1945, diameter of *standard generator drive gear on O.H.V. Models only* was increased. The larger diameter gear can be identified by measuring its outside diameter. Outside diameter of larger gear is 1.022", however, if edges of gear teeth are slightly burred, outside diameter of gear shown given. Diameter of smaller gear used previously was 1.000"

6. Unless a new generator gasket is available, to be used when generator is installed, be careful not to damage the old one.

GENERATOR SCREWS



GENERATOR CLAMP STRAP

ILLUS. 82  
REMOVING GENERATOR STRAP NUT

## Testing Field Coils and Brush Holders Without Disassembling Generator

**CAUTION:** Overloading ammeter, due to short circuit or otherwise, will damage it. Overload is indicated by needle going beyond range of calibrated scale; direct short is indicated by needle swinging violently to extreme limit of its travel. In either case, contact must be broken instantaneously to avoid damaging or burning out ammeter. Therefore, in making the following tests with ammeter, first make only a momentary contact to determine if a short exists. If ammeter needle does not go beyond calibrated scale, it is safe to make continuous contact and proceed with test as described.

As an added precaution, in making tests with ammeter, always work on a bench with an insulated top. This will prevent shorting through bench top.

Never touch test points together.

Connect a fully charged battery to suitable test ammeter and test points as shown in Illus. 83.

Remove the brushes from their holders (see "Inspecting or Replacing Generator Brushes,"

Removing main brushes requires removing screws connecting field coil terminal wires to brush holders.

### Model 32E and 32E2 — Standard and Radio Three Brush Generator

1. Remove resistor from generator "relay" and "switch" terminals of a *Radio* generator before making tests.

2. Reconnect field coil wires to positive and negative brush holders before making tests.

*Testing Regulating Field Coil (see Illus. 83):*

3. Touch test point "A" to "relay" terminal of generator and test point "B" to third (regulating) brush holder. The ammeter should read as follows:

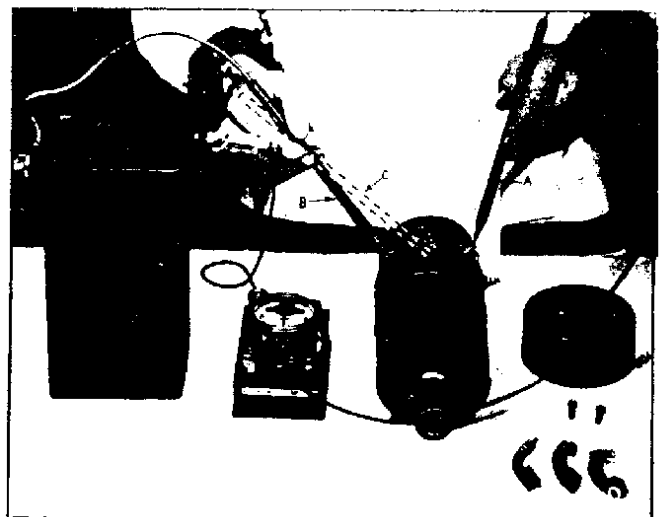

ILLUS. 83  
TESTING REGULATING FIELD COIL STANDARD AND RADIO THREE BRUSH GENERATOR

Standard Generator from 1.4 to 1.9 amperes; Radio Generator, 1.9 to 2.3 amperes. If ammeter shows no reading, field coil is open (see that terminal connections are tight and field coil wires are not broken at terminals). If reading is appreciably higher than—Standard Generator 1.9 amperes; Radio Generator, 2.3 amperes, field coil is shorted internally.

4. With test point "A" still on "relay" terminal, ground other test point by moving it to generator frame as indicated by dotted line "C". Ammeter should show no reading on this test. If ammeter registers a reading, field coil, "relay" terminal, positive brush holder or third brush holder is grounded. If test shows ground, disconnect field coil wire from third brush holder. If trouble is eliminated, third brush holder is grounded. If ground still exists, disconnect field lead from positive brush holder. If trouble is now eliminated, ground is in field coil. If ground still exists the positive brush holder or "relay" terminal is grounded.

#### Testing Shunt Field Coil (see Illus. 84):

5. Touch test point "D" to "switch" terminal and test point "E" to negative brush holder (this brush holder is grounded) or on generator frame. Ammeter should read as follows: Standard Generator,



ILLUS. 84

TESTING SHUNT FIELD COIL—STANDARD AND RADIO THREE BRUSH GENERATOR

from .6 to 1.0 ampere; Radio Generator, .8 to 1.2 amperes. If ammeter shows no reading, coil is open (see that terminal connections are tight and field coil wires are not broken at terminals). If reading is appreciably higher than—Standard Generator 1.0 ampere; Radio Generator 1.2 amperes, coil is shorted internally or grounded, or "switch" terminal is grounded.

#### Model 32E2 and 32E2R—Radio Two Brush Generator

Field coil wires disconnected when positive (upper) brush is removed, must remain disconnected and terminals must not touch any part of generator frame when making tests. Do not disconnect field

coil wires from field coil wire terminal (connected with "switch" terminal) unless necessary.

#### Testing Regulating Field Coil (see Illus. 85):

1. Touch test point "F" to "switch" terminal of generator and test point "G" to disconnected regulating field coil wire terminal. The ammeter should read between 1.9 to 2.3 amperes. If ammeter shows no reading, field coil is open (see that terminal connections are tight and field coil wires are not broken at terminals). If reading is appreciably higher than 2.3 amperes, field coil is shorted internally.

2. With test point "F" still on switch terminal, ground other test point by moving it to generator frame, as indicated by dotted lines "I". Ammeter should show no reading on this test. If ammeter registers a reading, either or both field coils, or "switch" terminal is grounded.

3. If test shows ground, disconnect field coil wires from field coil terminal. If ground is eliminated, one or both field coils are grounded. If ground still exists, "switch" terminal is grounded.

#### Testing Shunt Field Coil (see Illus. 85):

4. If testing regulating field coil did not necessitate disconnecting field coil wires from field coil terminal because of a ground, touch test point "F" to "switch" terminal and other test point to disconnected shunt field coil wire as indicated by dotted lines "H". The ammeter should read .8 to 1.2 amperes. If ammeter shows no reading field coil is open (see that terminal connections are tight and field coil wires are not broken at terminals). If reading is appreciably higher than 1.2 amperes coil is shorted internally.

5. If test showed that a field coil is grounded, the defective coil can be identified by ammeter registering a reading when touching test point "F" to one field coil wire terminal and other test point to generator frame. Check each field coil separately.

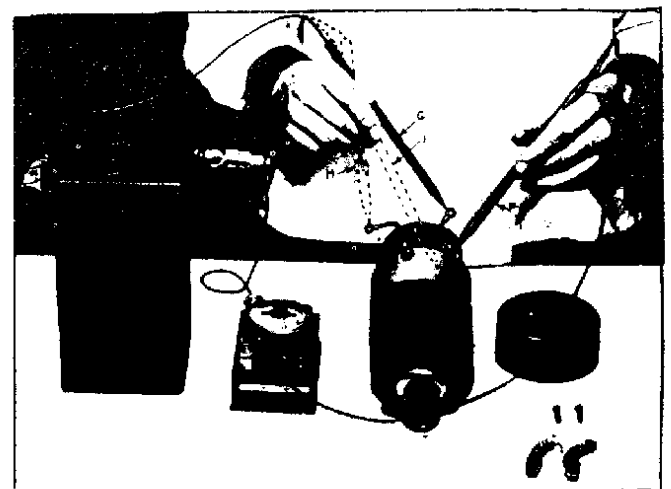

ILLUS. 85

TESTING REGULATING AND SHUNT FIELD COILS—RADIO TWO BRUSH GENERATOR

### Testing Relay Terminal and Positive Brush Holder (see Illus. 86):

6. Touch test point "J" to "relay" terminal and test point "K" to generator frame. Ammeter should show no reading. If ammeter registers a reading, positive brush holder or "relay" terminal is grounded.

Make sure negative brush holder is tight and making good contact with frame end to insure a good ground connection.

If field coils, brush holders and generator terminals test O.K., armature must be removed and tested.

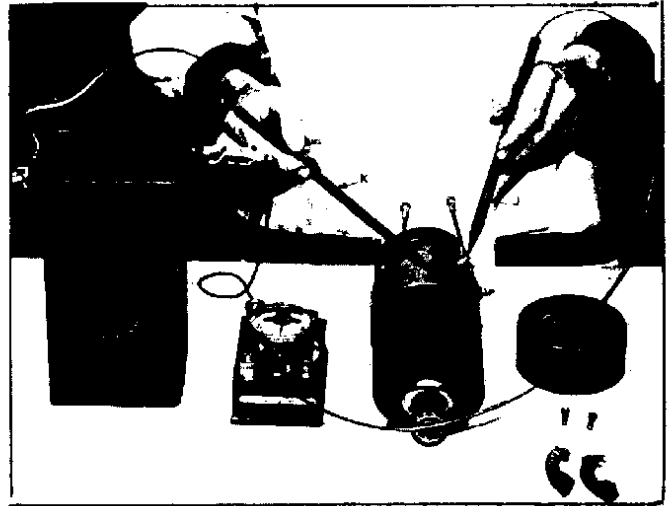

ILLUS. 86

TESTING RELAY TERMINAL—RADIO TWO BRUSH GENERATOR

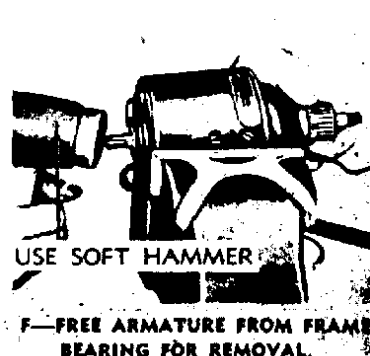
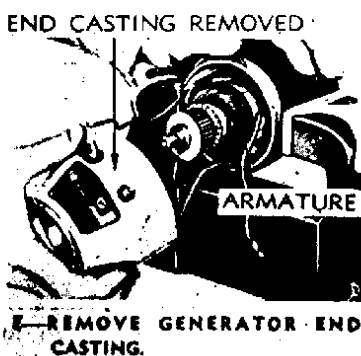
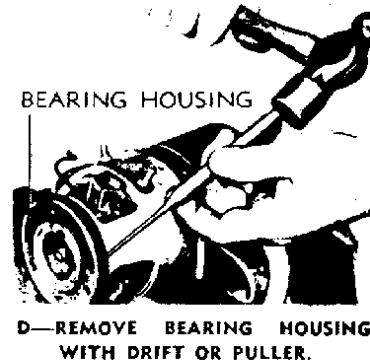
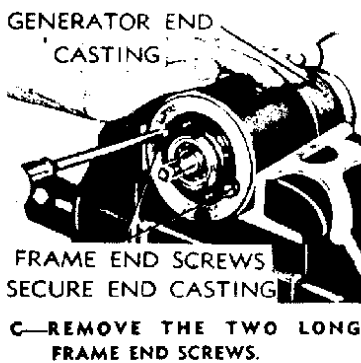
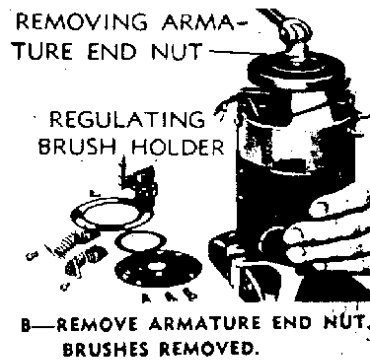
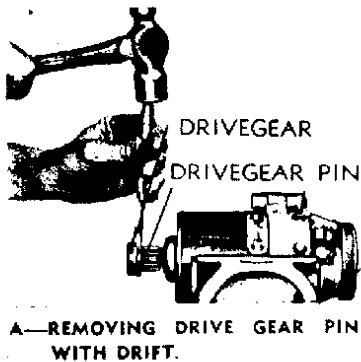
ILLUS. 87  
DISASSEMBLING GENERATOR

### Disassembling Generator

(To Identify Items, Refer to Illus. 79 or 80—also Refer to Illus. 87 and 88)

1. End cover and brushes have already been removed for previous checking and testing.

2. Disconnect field wires. Closely observe how field coil wires are arranged to keep them in the clear so they will not be damaged by armature. One is pulled between generator frame and frame end screw, and one is brought over the outside of aluminum frame end. Also, excess slack is avoided by winding wires together, where they cross at brush holders. The arrangement of wires shown in Illus. 88 applies to three brush type generator only, but method of winding wires together to keep them in the clear also applies to two brush type generator. Note this arrangement and arrange wires in the same manner when reassembling.

3. *Standard Generator*—remove pin from drive gear; remove gear, spring and oil deflector (1, 2, 3 and 4).

*Radio (Two Brush) or (Three Brush) Generator*—remove pin from oil centrifuge or clutch spring collar; remove oil centrifuge or clutch spring collar, spring, gear, clutch and oil deflector (1, 2, or 2D, 3, 2B, 2C, and 4).

4. Clamp armature shaft in copper-faced vise jaws with generator in upright position.

5. Take out three end screws and remove outer grease retainer, gasket and third brush holder, or generator end plate (50, 51, 52 and 53).

6. Remove armature shaft nut and lock washer (46) and (47).

7. Remove bearing housing, gasket, bearing and inner grease retainer (40, 41, 42 and 45).

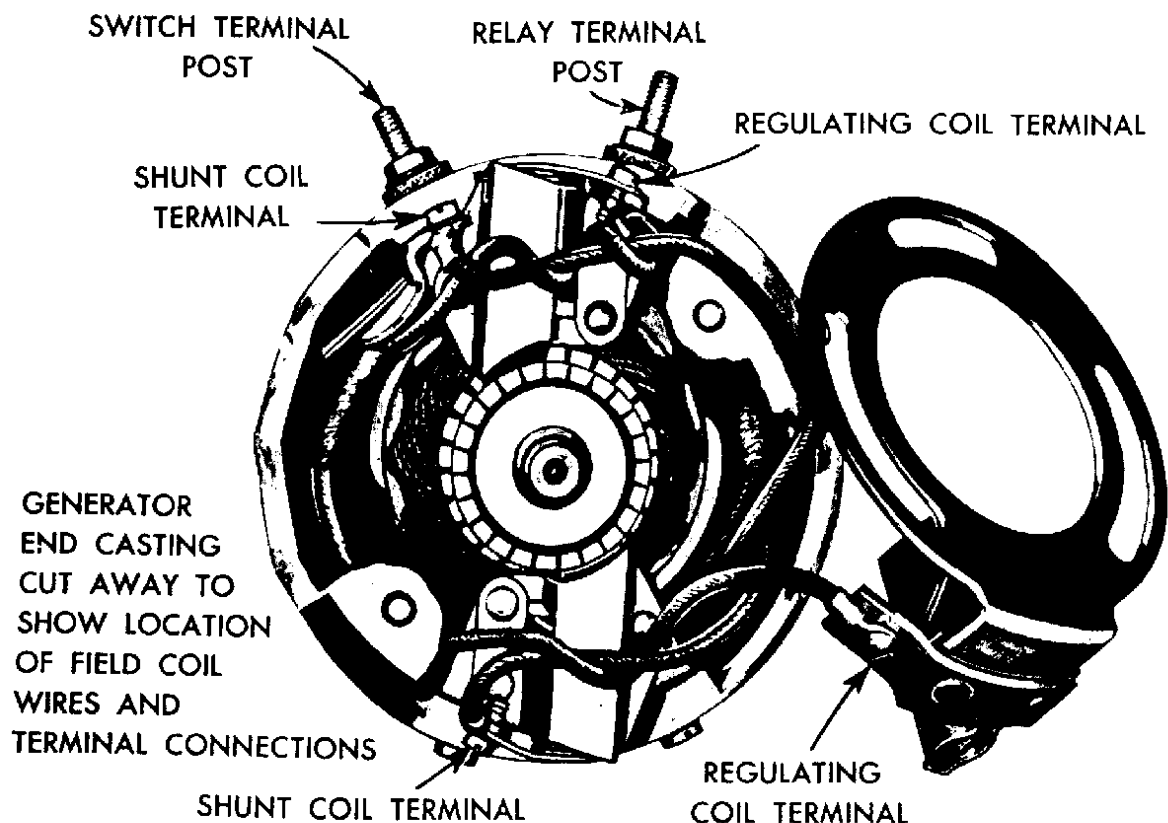

ILLUS. 88  
GENERATOR SECTION SHOWING ARRANGEMENT AND CONNECTIONS FOR FIELD COIL LEADS —  
THREE BRUSH GENERATOR

8. Remove steel and fibre washers from armature shaft (18, 19 and 20).

9. Take generator out of vise and remove frame end screws (8) and (12). If gasket is still on end of generator frame, it will have to be removed to uncover the heads of these screws. Before turning screws all the way out (leave at least two threads engaged), tap them lightly to drive aluminum frame end (21) off frame (10).

10. Remove armature (15) from frame by tapping drive end of shaft lightly with a soft hammer.

11. Drive end bearing can now be removed; also spring ring and felt oil retainer (5, 6 and 7). Later *Standard Generator* only has an oil seal in place of felt oil retainer (7).

12. Do not remove pole shoes and field coils (13, 14, 16 and 17) unless tests previously made proved one or both of the field coils in bad order. They should be removed only for good reason, as difficulty may be experienced in reassembling so they allow specified armature clearance. When a pole shoe (14) or (16) and field coil (13) or (17) must be removed, clamp generator frame lightly in vise and remove screws (9) or (11) with a large screwdriver as shown in Illus. 89. These screws are very tight and difficulty will be experienced in removing them unless screwdriver bit is in good shape and seats fully in screw slot.



ILLUS. 89  
REMOVING FIELD COILS

## Testing Armature

### To Test for "Ground":

If growler with test points is available, test as shown in Illus. 90. If this means of testing is not available, test with battery and ammeter hook-up, same as used for testing field coils. Contact commutator with one test point and armature core with the other. If circuit is completed, armature is grounded.

If armature is found to be grounded, make sure commutator is free from carbon and copper dust deposits. After cleaning thoroughly between segments and at ends of commutator and blowing off thoroughly with compressed air, repeat test. If ground still exists, armature must be replaced with a new one.

### "Growler" Test for "Short":

Place armature in "growler" and hold piece of hacksaw blade in loose contact with armature core as shown in Illus. 91. Turn "growler" "ON". Rotate armature slowly one or more full turns. If armature is shorted, hacksaw blade will be attracted to armature core and will vibrate violently at one or more points around armature.

If short is found, clean thoroughly between commutator segments as described under "ground" test, and test again. If short still exists, armature must be replaced with a new one.

### "Growler" Test for "Open":

Place armature in "growler" as shown in Illus. 92 and turn "growler" "ON." Insert tip of hacksaw blade between segments that are closest in alignment with the point of contact of armature core and "growler" V. Make and break contact between segments with hacksaw blade.

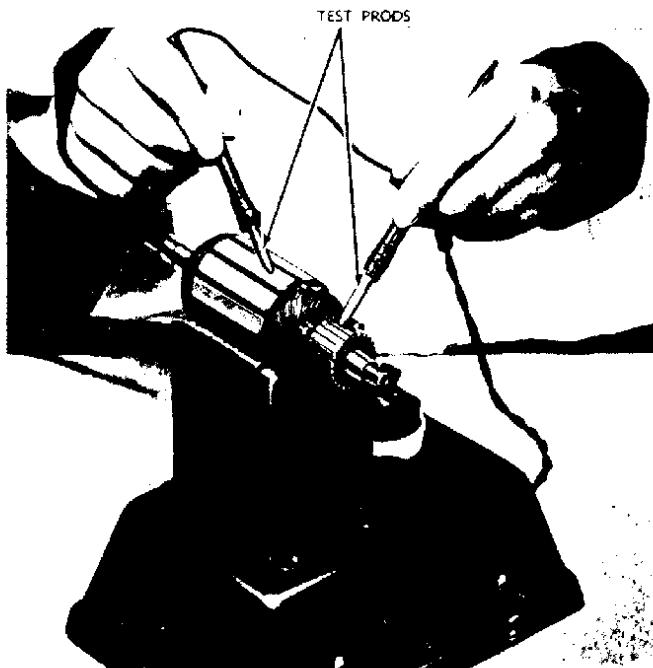

ILLUS. 90  
TESTING ARMATURE FOR "GROUND"

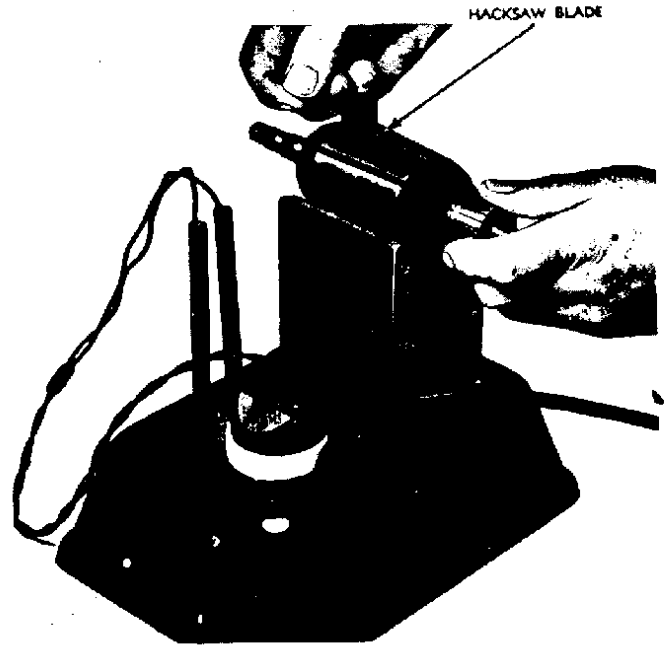

ILLUS. 91  
TESTING ARMATURE FOR "SHORT"

A strong flash should be seen as contact is broken. No flash or a very weak flash indicates an open circuit.

Repeat this test between all segments, turning armature so that each test is made on the line of contact between armature core and "growler" V. If an open circuit is found check for loose or broken wires at commutator connections. If none are found that can be repaired, armature must be replaced with a new one.

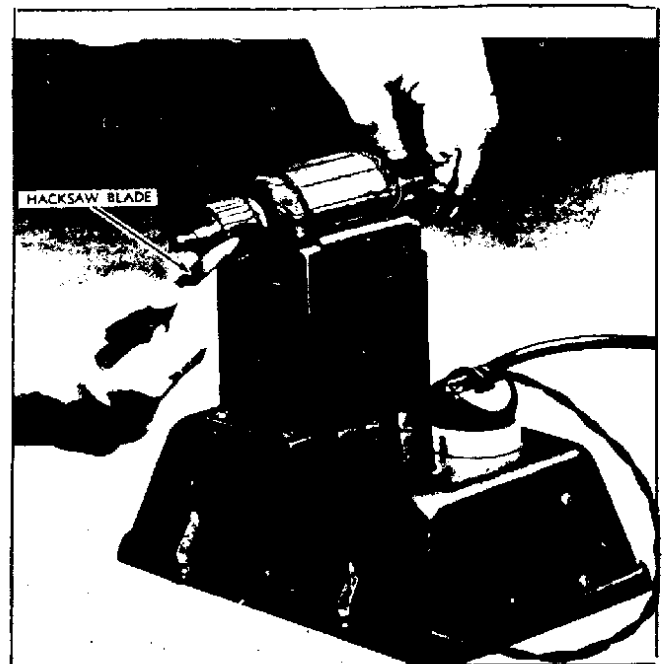

ILLUS. 92  
TESTING ARMATURE FOR "OPEN"

## Turning Down Commutator

If commutator is found worn and irregular, it should be turned down in a lathe and smoothed with No. 00 sandpaper. When turning, mount armature shaft on its bearing seats; do not mount on shaft centers.

## Undercutting Commutator

After commutator has been turned down, the mica insulation between segments must be undercut to a depth of approximately .025". Unless mica is properly undercut, brushes will not seat firmly against commutator segments and generator output will not be normal. Also, there will be excessive arcing at brushes.

Undercutting is usually done with a special undercutting machine. However, if such a machine is not available, it can be done as shown in Illus. 93.

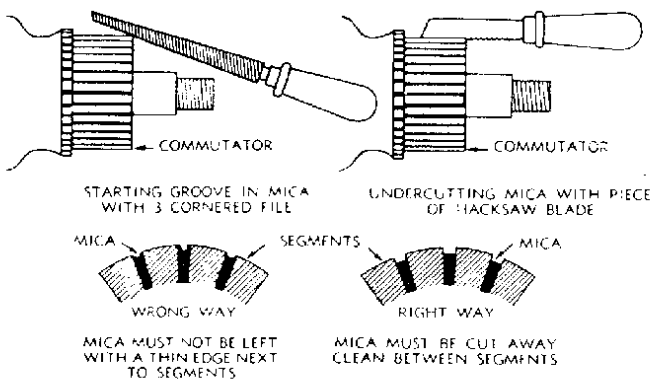

ILLUS. 93  
UNDERCUTTING COMMUTATOR MICA

After undercutting is completed, again smooth commutator with No. 00 sandpaper. It is also advisable to repeat "growler" check for "short" as there is a possibility of developing a "short" during the turning and undercutting operations. If so, it can very likely be corrected by more thorough cleaning between segments and at ends of commutator.

## Reassembling Generator

(To Identify Items, Refer to Illus. 79 or 80)

1. If one or both field coils have to be reassembled, do this first. Remember that field coils (13) and (17) are not alike and must not be interchanged. If one has to be replaced, be sure it is replaced with one of same type.

Thoroughly clean generator frame where pole shoe seats and also clean face of pole shoe that seats against frame. Tighten pole shoe screws (9) and (11) as tight as possible, with a large screwdriver that fits well into screw slot. Unless screws are very tight, there will not be the required clearance (.007" or more) between armature and each pole shoe (this clearance is to be checked later when armature is assembled into frame).

2. Proceed with further assembly of generator.

reversing order of disassembly as outlined under "Disassembling Generator,"

3. If felt oil retaining washer (7), or oil seal explained in paragraph 11, under "Disassembling Generator," is worn, renew it.

4. Thoroughly wash and closely inspect both the drive end and commutator end bearings, (5) and (42). If either is found worn to any extent, or pitted and rough, renew it. The commutator end bearing particularly should be replaced if it shows any appreciable wear, as a loose bearing allows commutator to run eccentric and chatter, even though commutator itself is perfectly true. Pack both bearings with high melting point grease (Harley-Davidson grade "A" grease).

### 5. Gauging Armature Pole Shoe Clearance:

Select a sheet of paper .007" thick or use a double sheet totaling this thickness. Cut a piece as wide as length of armature core and long enough to wrap nearly, but not quite, around armature.

Assemble armature in frame with this paper around it, inserting shaft through drive end bearing. If pole shoe clearance is up to the required .007" or more on each side, armature can be inserted and will turn freely. If it binds, pole shoe or shoes removed and replaced must be pulled tighter to frame with pole shoe screws. Possibly parts were not well cleaned and there are particles of dirt between shoe and frame, preventing full seating.

Specified pole shoe clearance is necessary to allow for expansion of armature when hot and for play that normally develops due to bearing wear. Taking a chance on less than specified clearance may result in armature striking pole shoe and damaging both the armature and pole shoe. An armature damaged in this manner is usually grounded and must be renewed.

6. *Installing Frame End:* Generator frame end fits over register in frame and is located by a dowel pin in frame and a corresponding hole in frame end. Frame end must be a snug fit on frame register or a new end must be installed. If frame end is loose on frame, armature-pole shoe clearance is affected and the likely result is a damaged armature. Tighten screws securely.

7. Complete assembly of generator. Be sure pin that secures drive gear, oil centrifuge or spring collar is well riveted at both ends to prevent it from coming out in service and causing serious damage to timing gears and other parts. *Side Valve Engine only:* Measure the distance from outer face of oil centrifuge on end of armature shaft to end of generator frame (gasket removed). This distance should be 1-53/64" to 1-27/32". Adjust if necessary by removing or adding an armature spacer (18).

Connect field coil wires according to Illus. 96 or 97 and paragraph "2" under "Disassembling Generator,"

Test generator on test stand if this equipment is available. If not, install on engine and test. Generator output can be adjusted as follows: Three

brush generator—by moving third brush; two brush generator—by adjusting current and voltage regulator. See "Generator Charging Rate."

### Assembling Generator to Engine

Reverse the operations followed in "Removing Generator," also refer to "Installing Generator."

Make sure same number of paper shims are used in reassembling as were found underneath generator when it was removed. After an engine has seen considerable service and gears have worn to some extent, they have possibly developed enough lash or play to permit safely removing one or more of the original shims and thus effecting closer meshing and quieter operation. However, this should not be done unless timing gear case cover is removed so gear mesh and lash can be carefully checked.

Make sure all external wire connections are correct and tight.

### Generator Charging Rate

(The following maximum rates specified are battery charge over equipment loads indicated, which do not include sidecar lighting, using test ammeter at battery ground.)

#### 1. Standard Generator:

A maximum charging rate of about 4 amperes with standard equipment tail lamp, speedometer light and headlamp lighted (headlamp on upper light beam) is standard factory setting.

#### Radio Three Brush Generator:

A maximum charging rate of about 2 amperes with radio and standard equipment tail lamp, speedometer

light and headlamp lighted (headlamp on upper light beam) is standard factory setting. If motorcycle is used without radio, remove resistor from generator "relay" and "switch" terminals, and adjust charging rate to a maximum of about 4 to 5 amperes with the above standard equipment lamps lighted.

**All Three Brush Generators:** Standard factory setting should be sufficient to keep battery in a good state of charge under normal service conditions. At average driving speeds, the charging rate is about the same with lights either "ON" or "OFF" because when lighting switch is "ON" generator output is automatically boosted enough to take care of the standard lighting equipment. The charging rate can be adjusted higher or lower as desired to meet unusual service conditions, but bear in mind that a higher than normal charging rate is likely to overcharge, overheat and damage battery.

When it is found necessary to adjust charging rate, proceed as follows: Remove generator end cover, and loosen screws that hold the regulating brush (small brush) plate assembly to generator frame end. Then shift regulating brush to the right to increase charging rate—to the left, to decrease charging rate. Shift brush only a little at a time, until desired maximum charging rate is obtained (see Illus. 94).

#### 2. Radio Two Brush Generator:

A maximum charging rate of 11 to 12 amperes (over ignition only) controlled by current and voltage regulator. When battery voltage is low, regulator will limit generator to about 11 to 12 amperes, and after battery voltage is up to normal, regulator will then limit generator to very low charging rate. If regulator does not control generator within specified limits, see "Current and Voltage Regulator."

### Inspecting or Replacing Generator Brushes

Remove the two screws in generator end cover and pull off cover, exposing the commutator and brushes. Brushes can be taken out after unfastening spring retainers. To unfasten small (regulating) brush spring retainer, simply press it downward and outward. Remove fastening screw from each of the larger brush spring retainers.

Brushes are worn out and should be renewed when longest side of brush measures  $\frac{3}{8}$ " or less.

Be sure to insert brushes into holders so that concave face of brush fits curve of commutator.

### Cleaning Commutator

Remove footboard, clutch footpedal assembly, and generator end cover. If oil or grease has worked out of bearings and onto commutator, wipe it off first with a rag moistened with gasoline or solvent and then sandpaper until commutator is bright, using No. 00 sandpaper. CAUTION: Never use emery cloth to clean commutator. See "Generator Charging Rate."

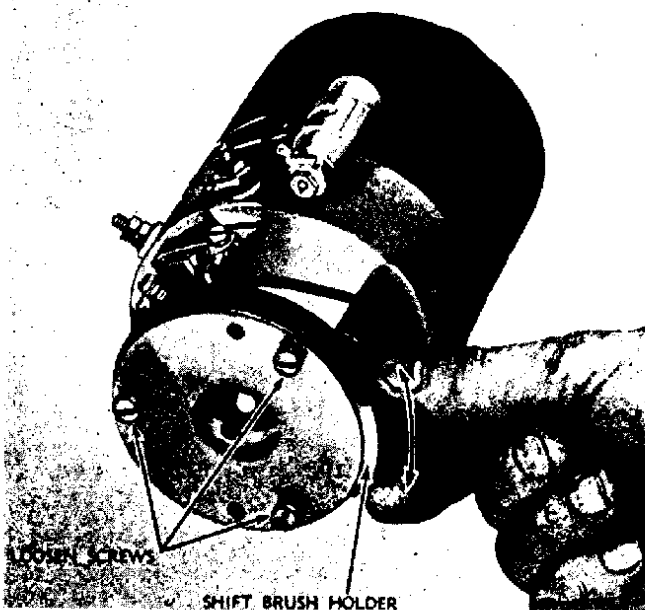

ILLUS. 94

SHIFTING REGULATING (THIRD) BRUSH TO ADJUST CURRENT OUTPUT OF GENERATOR

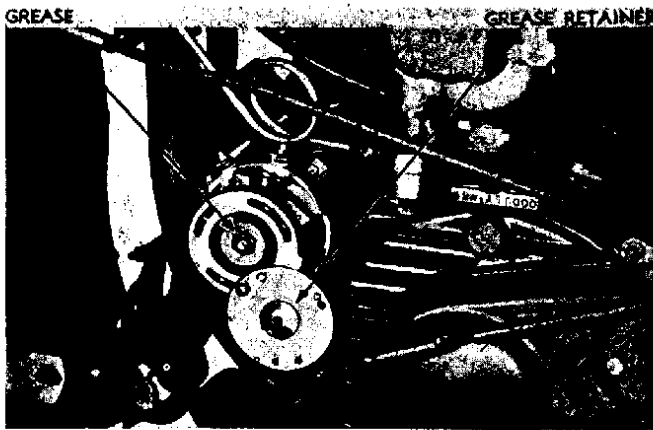

ILLUS. 98  
GREASING COMMUTATOR END ARMATURE BEARING

### Lubricating Commutator End Armature Bearing

(To Identify Items, Refer to Illus. 79 or 80—  
Also Refer to Illus. 99)

To lubricate bearing (42) it is necessary to first remove end cover (54). Then bearing can be oiled through hole in outer grease retainer (52) or outer grease retainer can be shifted to expose bearing and permit greasing as follows:

Take out two of the three outer grease retainer screws (53) and loosen the third screw slightly to permit shifting outer grease retainer to one side. Pack bearing with high melting point grease (Harley-Davidson grade "A" grease). After greasing, replace outer grease retainer. **CAUTION:** If outer grease retainer is completely removed or two of the screws are removed and the third screw is made very loose, regulating brush holder (50) is free to move and thus change charging rate. Therefore; before retightening outer grease retainer screws be sure that regulating brush holder has remained in its original position.

If not convenient to grease bearing at specified interval, at least lubricate with a few drops of engine oil. Be careful that this bearing is not over-lubricated, as excess oil will very likely work out of bearing and some may get onto commutator and brushes.

Generator drive gear end bearing requires no attention as it is lubricated by the oil that circulates through engine.

### Cut-Out Relay

(Refer to Illus. 99)

#### Adjusting Points and Air Gap

The cut-out relay is provided with an additional contact for the normally open position to control the generator signal light in instrument panel. When the generator voltage exceeds battery voltage (between 6.3 and 6.8 volts) the relay closes the battery-generator circuit. At this time, the upper contact points

break and the instrument panel indicator light goes off, indicating that generator is charging the battery. This occurs at approximately 20 miles per hour in high gear.

The relay contact points must be correctly adjusted and the armature must have correct spacing above magnet core for sensitive and correct cut-in and cut-out operation.

**Armature and core air gap:** The space (air gap) between the armature and magnet core end should be .015" when the two upper points are in contact. Bend upper contact point support and adjust armature to obtain this gap.

**Main contact point gap:** After armature and magnet core end air gap have been adjusted, gauge the main contact point gap. It should be .020" and can be obtained by bending the lower point support up or down as may be necessary.

**Signal light point gap:** Press the armature down until the lower main points are in contact and gauge the upper contact point gap. It should be .020" and can be obtained by bending the upper point support up or down as necessary.

**Adjusting armature spring tension:** The relay main lower points should close at 6.3 to 6.8 volts (connect voltmeter to relay terminal marked "GEN" and to the relay base), and can be adjusted by decreasing or increasing the armature spring tension. Increasing spring tension increases the closing voltage—decreasing spring tension reduces closing voltage. The armature spring tension is altered by bending the spring stop, mounted on top of magnet, up or down.

#### Testing Cut-Out Relay

If it has been determined that point setting and air gap are correct and relay does not function, test as follows:

With relay removed from motorcycle, and using a 110 volt test lamp, place one test point on "GEN" terminal of relay and other test point on relay base. If lamp does not light, it indicates an open circuit in shunt (voltage) coil which will prevent contact points from closing.

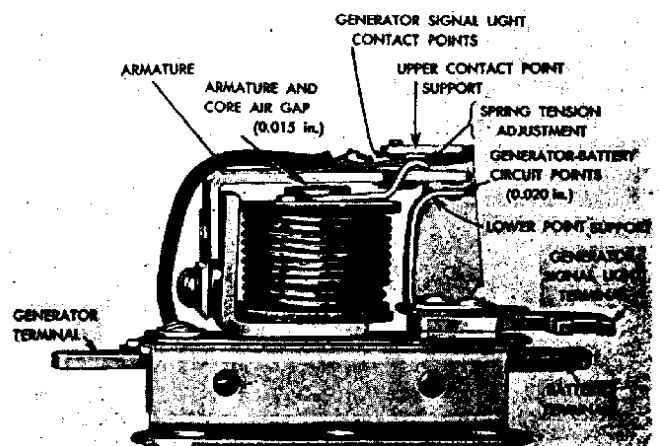

ILLUS. 99  
CUT-OUT RELAY



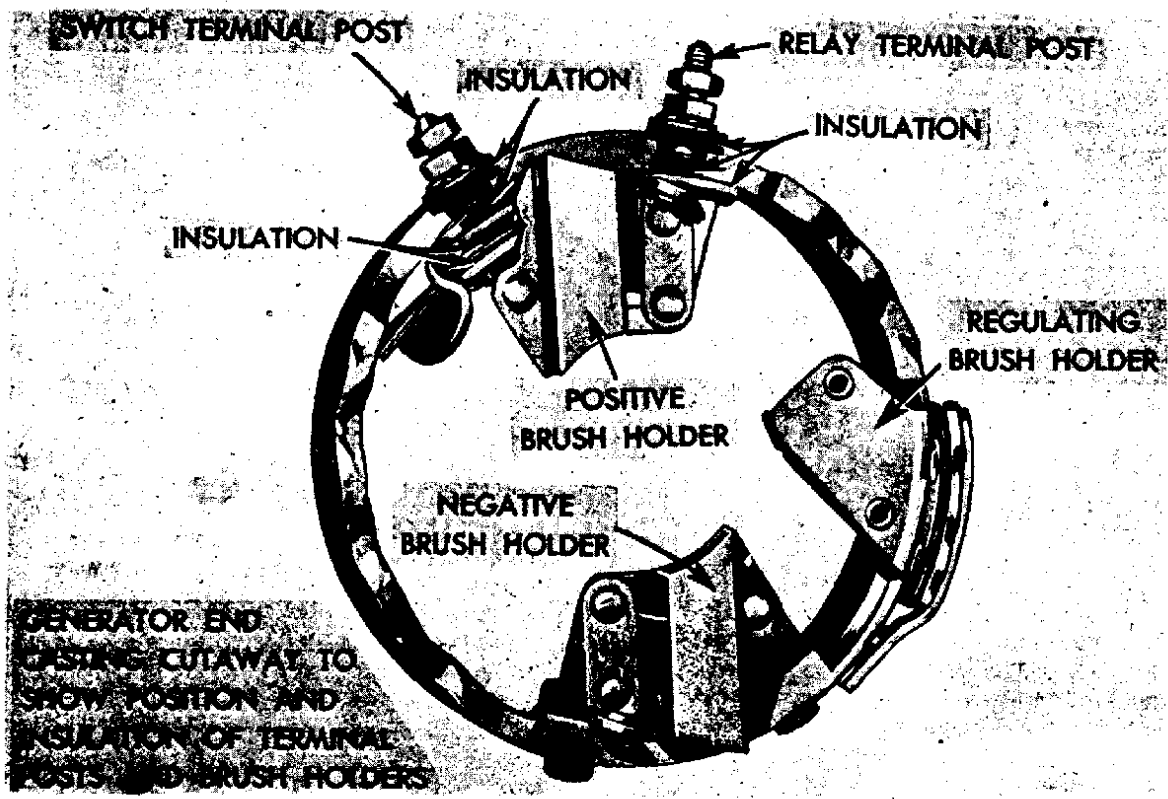

ILLUS. 95  
GENERATOR END SECTION SHOWING TERMINAL AND BRUSH HOLDER INSTALLATION

THIS .0005 MFD CONDENSER IS USED ONLY WITH A GENERAL ELECTRIC ULTRA-HIGH FREQUENCY RADIO. IT IS MOUNTED UNDER END COVER AND CONNECTED FROM POSITIVE BRUSH HOLDER TO GENERATOR FRAME.

"SWITCH" TERMINAL POST—CONNECT TO REGULATOR TERMINAL MARKED "F"

REGULATING FIELD COIL—IDENTIFIED BY ORANGE PAINT MARK

FIELD WIRE TO POSITIVE BRUSH

FIELD WIRE TO "SWITCH" TERMINAL POST

SHUNT FIELD COIL—IDENTIFIED BY WHITE PAINT MARK

"RELAY" TERMINAL POST—CONNECT TO REGULATOR TERMINAL MARKED "GEN"

.25 MFD CONDENSER—ATTACHED TO GENERATOR FRAME.

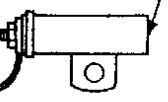

POSITIVE BRUSH HOLDER IN CONTACT WITH RELAY TERMINAL

FIELD WIRE TO POSITIVE BRUSH

FIELD WIRE TO "SWITCH" TERMINAL POST

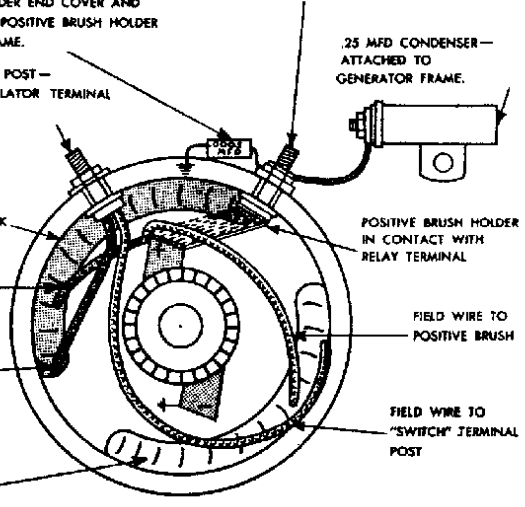

ILLUS. 96

SCHEMATIC DIAGRAM, SHOWING GENERATOR INTERNAL WIRING CONNECTIONS, LOCATION OF FIELD COILS AND BRUSHES IN RELATION TO EXTERNAL CONNECTIONS AND CONDENSER CONNECTIONS (RADIO TWO BRUSH GENERATOR). THIS GENERATOR CAN BE USED ONLY WITH CURRENT AND VOLTAGE REGULATOR

TO LIGHT "SWITCH"

FIELD WIRE TO POSITIVE BRUSH

REGULATING FIELD COIL IDENTIFIED BY ORANGE PAINT MARK

FIELD WIRE TO 3RD. BRUSH

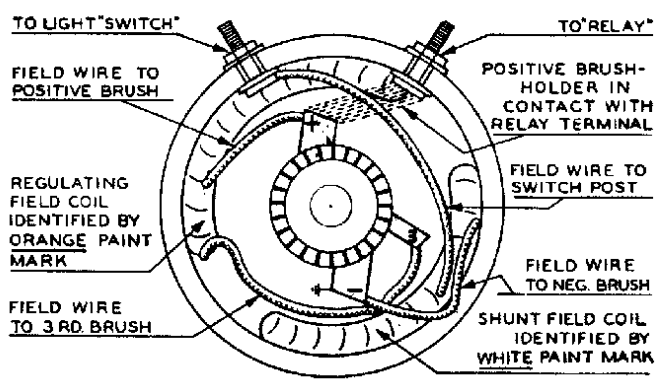

TO "RELAY"

POSITIVE BRUSH-HOLDER IN CONTACT WITH RELAY TERMINAL

FIELD WIRE TO SWITCH POST

FIELD WIRE TO NEG. BRUSH

SHUNT FIELD COIL IDENTIFIED BY WHITE PAINT MARK

ILLUS. 97

SCHEMATIC DIAGRAM, SHOWING GENERATOR INTERNAL WIRING CONNECTIONS AND LOCATION OF FIELD COILS AND BRUSHES IN RELATION TO EXTERNAL CONNECTIONS (THREE BRUSH GENERATOR). THIS IS THE STANDARD GENERATOR NORMALLY SUPPLIED ON ALL MOTORCYCLES—ALSO APPLIES TO RADIO THREE BRUSH GENERATOR.

With one test point on "GEN" terminal, and other test point on relay armature, test lamp should light. If it does not, it indicates an open circuit in series (current) coil.

If relay passes above tests, and generator is known to be O.K., but points do not close, it is an indication that series coil is grounded, or voltage coil grounded prematurely.

It is not practical to disassemble relay for repairs. A relay worn or damaged beyond adjustment service should be replaced.

Cut-out relay must be grounded; therefore, mounting screws must be tight.

### Current and Voltage Regulator

A current and voltage regulator is an electrical device that controls generator output, and is used with two brush generator only. Generator cut-out relay, current regulator unit and voltage regulator unit are all mounted on one base.

It is a special regulator as concerns its adjustment for proper regulation of a Harley-Davidson generator. Therefore, a regulator adjusted for an automobile generator cannot be used for regulation of a Harley-Davidson generator, otherwise serious damage to generator will very likely result.

The regulator is properly adjusted at factory when manufactured. Unauthorized persons must never tamper with adjustments as special equipment is required to properly adjust regulator. Under ordinary circumstances regulator will need very little attention in service.

If, however, regulator does need attention it should be referred to United Motor Service (located in many cities throughout the U.S.A.) who is authorized to service Delco-Remy regulators.

The following checks can be made to determine whether or not the units are operating normally. If not, the checks will indicate whether the generator or regulator is at fault, so that proper corrective steps may be taken.

Connect an ammeter between battery positive (left) terminal and regulator terminal marked "BAT".

Fully charged battery and a low charging rate indicates that regulator has reduced output, as it should when operating properly.

Fully charged battery and a high charging rate indicates that regulator is failing to reduce output as it should; due either to a faulty regulator or generator.

High charging rate to a fully charged battery causes battery to gas and overheat, also produces high voltage in the electrical system which may cause armature, coil, breaker point and lamp bulb failure.

To determine if regulator is at fault, disconnect "F" terminal lead at regulator to open generator field circuit. If charge rate drops to zero trouble has been isolated in regulator.

If charging rate continues, generator field circuit is grounded internally, or in wiring harness.

A low battery and a low or no generator charging rate indicates a high resistance in charging circuit, or regulator or generator is faulty.

Check wiring for loose connections or frayed or damaged wires. High resistance resulting from these conditions will prevent normal charge from reaching battery. If wiring is in good condition, then regulator or generator is at fault.

Ground "F" terminal of regulator temporarily and increase generator speed. Avoid excessive speed for any length of time as generator output may be dangerously high and damage to generator may result.

1. If generator output does increase, regulator needs attention.

2. If generator output remains low with "F" terminal grounded, generator is at fault and should be checked further.

3. If generator does not show any output either with or without "F" terminal grounded, disconnect wire from "GEN" terminal of regulator and strike it against a convenient ground with generator operating at medium speed. If a spark does occur, cut-out relay is not functioning to permit current to flow to battery. If no spark occurs, generator is at fault and will need further attention. See "When Generator Fails to Charge."

**CAUTION:** It is advisable to "flash" field coils whenever wires have been removed from generator or regulator; or after generator or battery has been removed and is reinstalled. This is done to make sure generator has correct polarity. If polarity of generator is reversed, relay points will vibrate and burn. "Flash" field coils by momentarily touching a jumper wire between "BAT" terminal and "GEN" terminal on regulator, after all wires have been properly connected and before starting engine. The momentary surge of current from battery to generator will correctly polarize generator.

### MEMORANDA

Total Field Draw - 2 amps  
Individual Field Draw - 8 amps

For flexuation check connections on field coils where they connect together.

Field leads out of generator body do not cross.

**ARMATURE** - 3 burned places on commutator indicates an open circuit. Check with light the individual commutator bars.

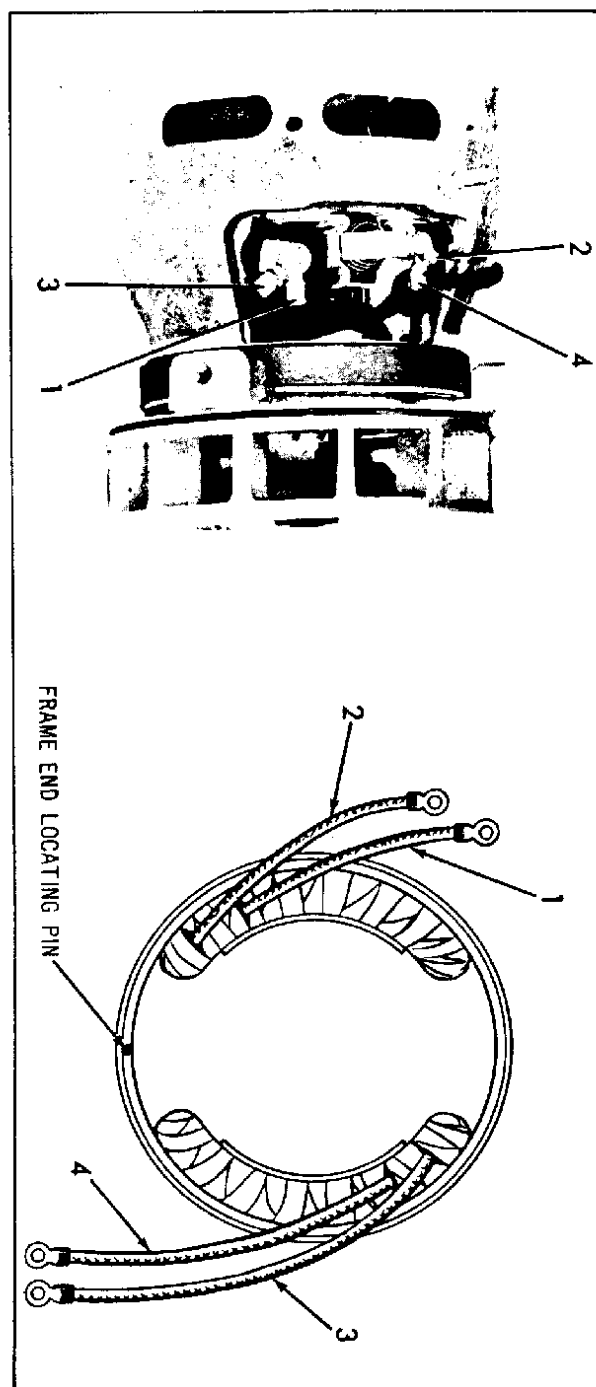

Figure 5E-6. Generator Wiring

#### MEMORANDA

Miles per hour compared to generator R.P.M.	Big Twin High Gear Ratio	Generator R.P.M.	M.P.H
4.76	21 T	3000	33
4.29 (61 OHV)	22 T	3000	35
3.73 (74 OHV)	23 T	3000	40

#### S & ST GENERATORS

To install brush holder on ST generator frames, drill out fibre brush holder with # 20 drill. Tap generator frame with 8-32 tap and secure brush holder with part number 2626 screw and 7115 lock washer.

#### FAN COOLED GENERATOR

The fan cooled generator is essentially the same as the standard, electrically, that is, It is a two-brush, shunt wound generator. Charge rate is governed by a current and voltage regulator. The difference is a larger physical size with higher current generating capacity, and it employs a fan to dissipate heat. Much of the technique used in testing the standard generator may be used in testing the fan cooled generator.

#### CHECKING GENERATOR

Before checking a generator believed to be faulty, check generator signal light as described in "Checking Generator", standard generator.

If generator signal light circuit is not shorted proceed as follows:

Disconnect any condensers found connected to generator "A" terminal. A shorted condenser will prevent generator from charging.

See Fig. 5E-7. Remove the three screws (1) and washers (2) securing the fan housing (3) and remove it. Inspect brushes to make sure they are not worn out, broken or gummy and sticking in holders.

#### TESTING GENERATOR OUTPUT

Test generator output as described in "Testing Generator Output," standard generator. Generator should generate 20 amperes or more. If it does not, trouble is in one or more of components listed.

#### REMOVING GENERATOR

**GLIDE.** Disconnect wires from generator "F" and "A" terminals. Remove two long screws through timing gearcase cover securing generator. Remove footshifter assembly and jiffy stand (footshifter model) or clutch assembly and jiffy stand (handshift model). Remove generator to left side of chassis.

**SERVI-CAR.** Disconnect wires from generator "F" and "A" terminals. Remove two long screws through timing gearcase cover securing generator and remove generator to left side of chassis, depressing clutch pedal to allow generator to pass.

#### TESTING FIELD COILS

The field coils of the model fan cooled generator are not spliced together so there are four leads rather than two.

Testing procedures are the same as described in "Testing Field Coils" on the standard generator except for following differences:

After step one remove parts number 4 through 19. (See "Disassembling Fan Cooled Generator"). Assemble terminal components eliminating field coil leads.

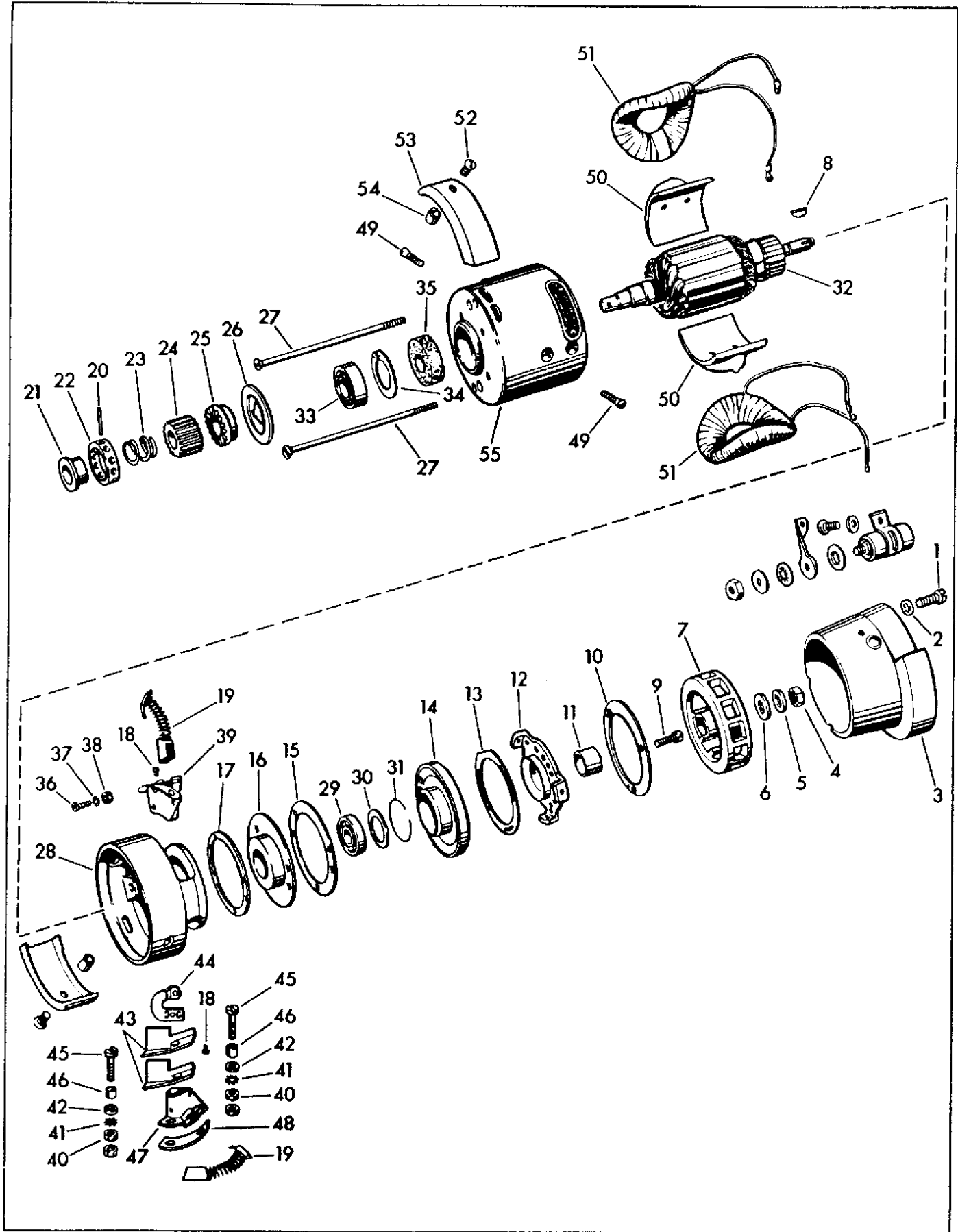

Figure 5E-7. Fan Cooled Generator

## LEGEND FOR FIGURE 5E-7

1. Fan housing screw (3)	19. Brush and spring (2)	38. Brush holder screw nut (2)
2. Internal lock washer (3)	20. Clutch spring collar pin	39. Brush holder (negative)
3. Fan housing	21. Clutch spring collar	40. Terminal screw nut (2)
4. Armature shaft nut	22. Oil slinger	41. Terminal screw lock washer (2)
5. Armature shaft lock washer	23. Clutch spring	42. Terminal screw insulating washer (2)
6. Armature shaft plain washer	24. Drive gear	43. Field coil terminal insulator (2)
7. Fan	25. Clutch	44. Field coil terminal
8. Armature shaft key	26. Drive end oil deflector	45. Terminal screw (2)
9. Fan baffle plate screw (3)	27. Frame screw (2)	46. Terminal screw bushing (2)
10. Fan baffle plate	28. Frame end	47. Brush holder (positive)
11. Fan spacer	29. Armature bearing	48. Brush holder insulation
12. Fan housing spider	30. Armature spacing shim (.020 in.)	49. Pole shoe screw (4)
13. End plate	31. Bearing plate spring ring	50. Pole shoe (2)
14. Brush end bearing housing	32. Armature	51. Field coil (2)
15. Drive end cover gasket	33. Armature bearing	52. Air intake shield screw (2)
16. Inner oil retainer	34. Drive end spring ring	53. Air intake shield (2)
17. Commutator end bearing shim (0 to 3)	35. Felt retainer	54. Spacing bushing (2)
18. Terminal screw (3)	36. Negative brush holder screw (2)	55. Generator frame
	37. Lock washer (2)	

Figure following name of part indicates quantity necessary for one complete assembly.

In step three, touch one test lead to generator frame, the other to either of two field coil leads, making sure other lead from same coil does not touch generator frame. Repeat process on other coil.

Omit step four.

In place of step five, touch ammeter leads to two field coil leads. Repeat process with opposite coil. Ammeter should read 1 ampere in both cases. No reading indicates an open coil, a higher reading indicates a shorted coil.

In step six, touch one test lead to generator frame, the other to positive (insulated) brush holder.

#### TESTING ARMATURE

Test armature as described in "Testing Armature," standard generator.

#### REPAIRING COMMUTATOR

Repair commutator as described in "Repairing Commutator," standard generator.

#### POLARIZING GENERATOR

Polarize generator as described in "Polarizing Generator," standard generator.

#### GENERATOR CHARGING RATE

Refer to directions in "Generator Charging Rate," standard generator, except minimum charging rate should be 20 amperes.

#### DISASSEMBLING GENERATOR Fig. 5E-7

Remove three fan housing screws (1), washers (2)

and fan housing (3). Turn off armature shaft nut (4) and remove lock washer (5) and plain washer (6).

Use All Purpose Claw Puller, Part No. 95635-46, to pull the fan (7). Remove key (8) (if used) from armature shaft.

Remove three fan baffle plate screws (9) and lift off baffle plate (10), fan spacer (11), fan housing spider (12) and end plate (13). Use Claw Puller to pull brush end bearing housing (14). Ball bearing (29) should come off with bearing housing and parts 30 and 31. However, the bearing sometimes stays on the shaft holding parts 15, 16, and 17, in place. In that event, do not remove bearing and go on to following procedure.

Remove terminal screws (18) and lift brush and spring assemblies (19) out of brush holders. At this point electrical checks to determine condition of field coils may be made (see "Testing Field Coils").

Drive clutch spring collar pin (20) out of clutch spring collar (21) on Glide, out of oil slinger (22) on Servi-Car. Slip clutch spring (23) and drive gear off armature shaft. Pull clutch (25) from shaft using All Purpose Claw Puller. Lift oil deflector (26) off shaft.

Loosen frame screws (27) about 1/4 in. and tap on ends to unseat frame end (28). Remove frame screws and pull frame end with bearing (29), gasket (15), oil retainer (16) and bearing shims (17) if there are any. In factory assembly, these shims are supplied as needed to center brushes on commutator. The usual assembly includes up to three spacing shims.

The armature (32) may be pressed out of the frame to release drive end ball bearing (33). If necessary spring ring (34) and felt grease retainer (35) can be removed.

There is no need to disassemble brush holders (39 and 47) from frame end unless test proves the positive holder is shorted, or unless they are badly bent or broken. If removal is necessary, turn out negative brush holder screws (36) and terminal screw nuts (40) to free all parts.

Do not remove pole shoe screws unless necessary to replace pole shoes or field coils. If necessary, turn out pole shoe screws (49) several turns, then tap on heads to loosen pole shoes (50) from keyed slots in frame before turning screws completely out.

Air intake shields (53) may be removed at any time convenient during the disassembly procedure.

#### CLEANING, INSPECTION AND REPAIR

Clean all parts except gaskets, felt grease retainer, armature field coils and brushes in cleaning solvent and blow dry with compressed air. Wipe armature, field coil and brushes clean with cloth dampened in white gas and blow dry with compressed air.

Examine all parts carefully for wear. Give close attention to condition of insulators, armature windings, field coil wrapping and surfaces of pole shoes nearest armature.

If play can be detected in ball bearings, replace them. Pack bearings, liberally with "Grease-All" grease before assembly of parts.

#### ASSEMBLING GENERATOR

Assemble generator in approximate order of disassembly. Install field coils in frame. Insert armature and assemble the felt retainer, spring ring and bearing. Use arbor press to push bearing in place.

Assemble brush holders to frame end and slip frame end in place over frame. If frame end is a tight fit, it may be drawn into place by tightening frame screws. Bring field coil leads (1, 2 and 3 Fig. 5E-6) through smaller opening in frame end and lead 4 through larger opening. Select lead ends 1 and 3. Run lead 1 behind field coil terminal, make loop and place it over field coil terminal. Twist leads 2 and 3 as in first half of shoe tying operation and secure to field terminal with terminal screw (18, Fig. 5E-7). Twist leads 2 and 4 in similar manner and attach to positive brush terminal with brush in place. Be sure lead 3 is behind frame screw. Assemble negative brush.

Assemble commutator end of generator in reverse of order disassembled, replacing same number of shims (17, Fig. 5E-7) that were removed.

Install generator in reverse order of removal as described in "Removing Generator," standard generator. Test generator as described in "Testing Generator Output," standard generator.

## Notes

# SHOP DATA:

## FAN COOLED GENERATOR

Watch the screw that secures the air intake shield to the aluminum end of the generator. If this screw is too long or is screwed down so forcibly that the shield crushes, the screw will enter so far into the generator body that it contacts the regulating field. The screw may puncture through the insulating wrapping and ground or short out the field. When this occurs generator will not charge.

Use a half inch screw, Part No. 036, with a generator terminal screw fibre bushing, Part No. 1665-32 under the air intake shield to prevent shield from collapsing and allowing screw to contact field. Originally the fan cooled generator did not have the fibre bushing under the shield. It is now installed at the factory and should be installed on all fan cooled generators in service at the earliest opportunity.

Usually, when field has been punctured, if the screw is unscrewed so it does not contact the field the generator will again charge normally, and apparently no harm has been done to the regulating field. However, if in doubt whether the field has been damaged or not, the field should be tested for current draw as described in the Big Twin manual on page 97 under "Testing Regulating Field Coil". If it is found that the regulating field draws more than 1.9 to 2.3 amperes, it is an indication that one or more turns of field coil winding are shorted out, and the field should be replaced.

THIS .0005 MFD CONDENSER IS USED ONLY WITH A GE ULTRA-HIGH FREQUENCY RADIO. IT IS MOUNTED UNDER END COVER AND CONNECTED FROM POSITIVE BRUSH HOLDER TO GENERATOR FRAME.

~"RELAY" TERMINAL~  
CONNECT WITH TERMINAL MARKED "GEN." ON REGULATOR

"SWITCH" TERMINAL  
CONNECT WITH TERMINAL MARKED "F" ON REGULATOR

.25 MFD CONDENSEN  
ATTACHED TO  
COMMUTATOR END COVER

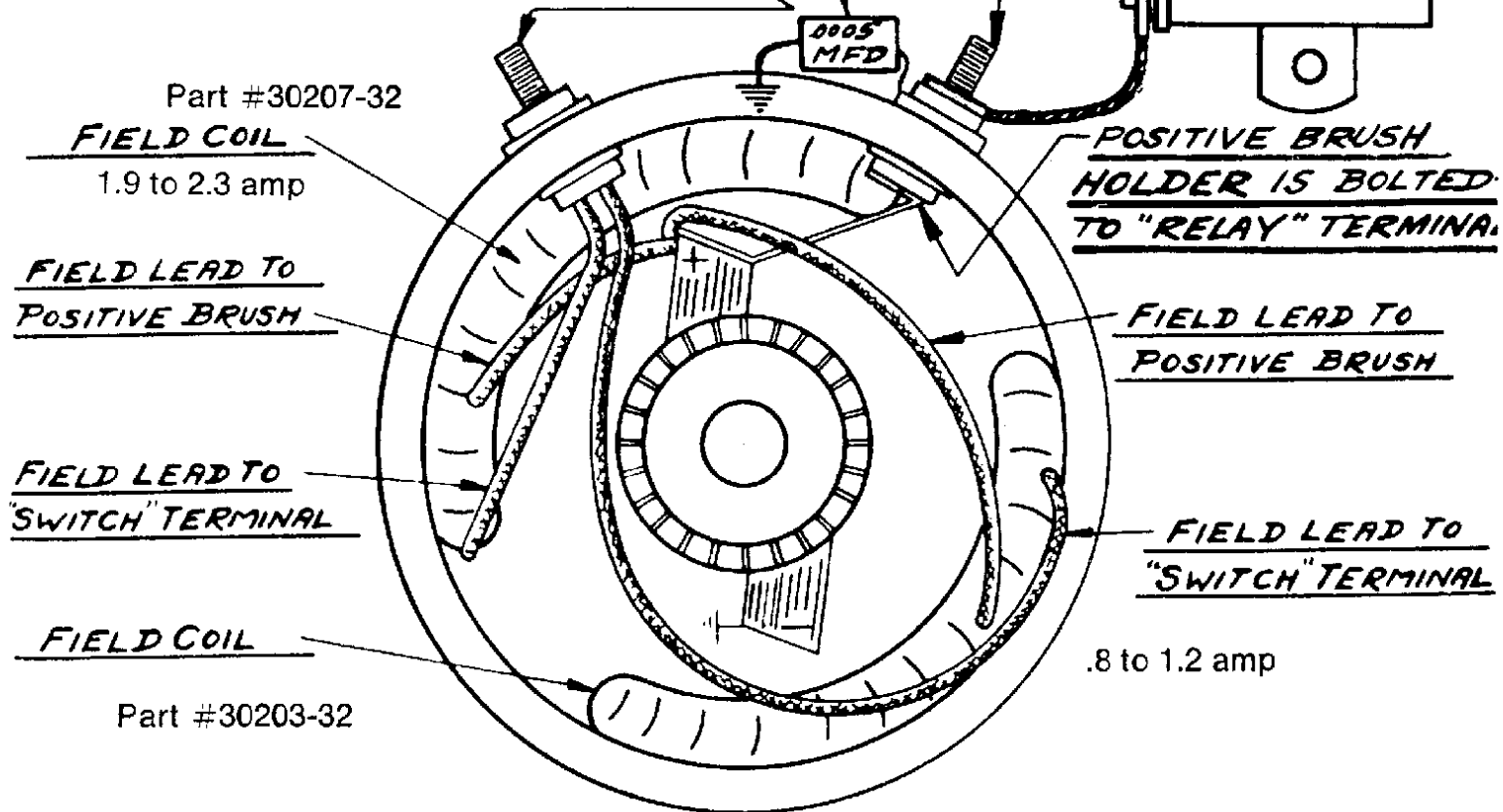

MODEL 32E2R RADIO GENERATOR

USED ONLY WITH CURRENT AND VOLTAGE REGULATOR

NOTE:- THIRD BRUSH IS DISCARDED.

Not fan cooled

To polarize all generators: Flash positive battery wire to relay generator post and ground wire to battery.



Install Model 51 field coil

"F" TERMINAL CONNECT WITH TERMINAL MARKED "F" ON REGULATOR.

POSITIVE BRUSH-HOLDER IS BOLTED TO RELAY TERMINAL.

RELAY TERMINAL CONNECT WITH TERMINAL MARKED "GEN." ON REGULATOR.

FIELD LEAD TO POSITIVE BRUSH.

1.9 to 2.3 amp REGULATING FIELD COIL.

Part #30207-32

FIELD LEAD TO POSITIVE BRUSH.

FIELD LEAD TO "F" TERMINAL.

FIELD LEAD TO 3RD. BRUSH.

1.9 to 2.3 amp SHUNT FIELD COIL.

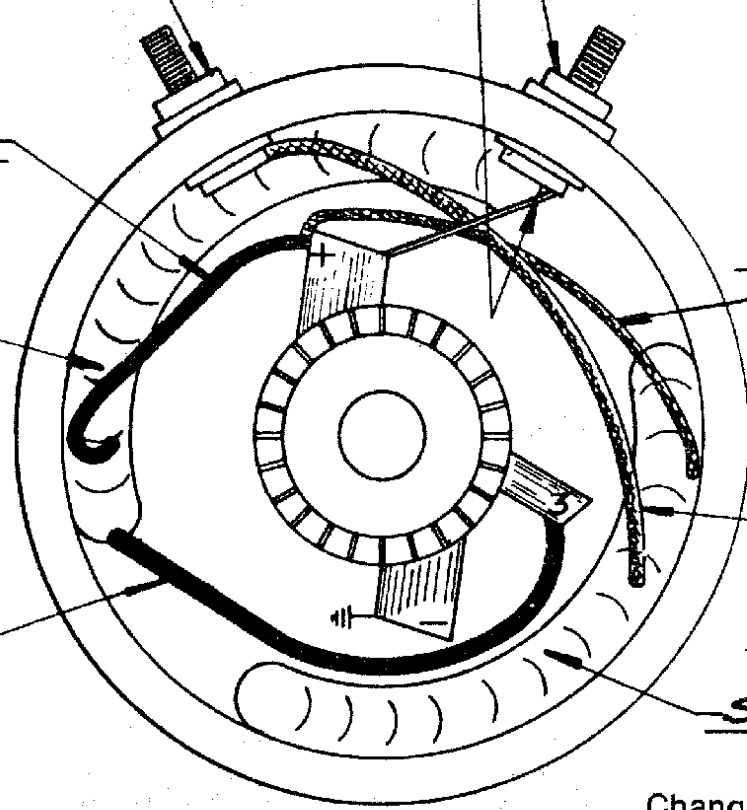

Change these models to two brush generator

(MODEL 48) - 3 BRUSH-FAN COOLED HEAVY DUTY (RADIO) GENERATOR WIRING DIAGRAM-SPECIAL EQUIPMENT 1949 TWIN MOTORCYCLES. USED WITH VOLTAGE REGULATOR PART NUMBER 74510-47.

Ground F terminal for full output

RELAY TERMINAL - CONNECT WITH  
TERMINAL MARKED "GEN."  
ON REGULATOR.

"F" TERMINAL - CONNECT WITH  
TERMINAL MARKED "F"  
ON REGULATOR.

Part #30203-32  
REGULATING  
FIELD COIL.

1.9 to 2.3 amp

FIELD LEAD TO  
POSITIVE BRUSH.

FIELD LEAD TO  
"F" TERMINAL.

SHUNT  
FIELD COIL.

FIELD LEAD TO  
POSITIVE BRUSH.

FIELD LEAD TO  
"F" TERMINAL.

.8 to 1.2 amp  
Part #30207-32

(MODEL 48) - 2 BRUSH - FAN COOLED -  
HEAVY DUTY (RADIO) GENERATOR  
WIRING DIAGRAM. SPECIAL EQUIPMENT  
1950-1951 TWIN MOTORCYCLES - USED  
WITH CURRENT AND VOLTAGE REGULATORS.  
PART NUMBERS 74511-41 OR 74511-51.

Ground F terminal for full output

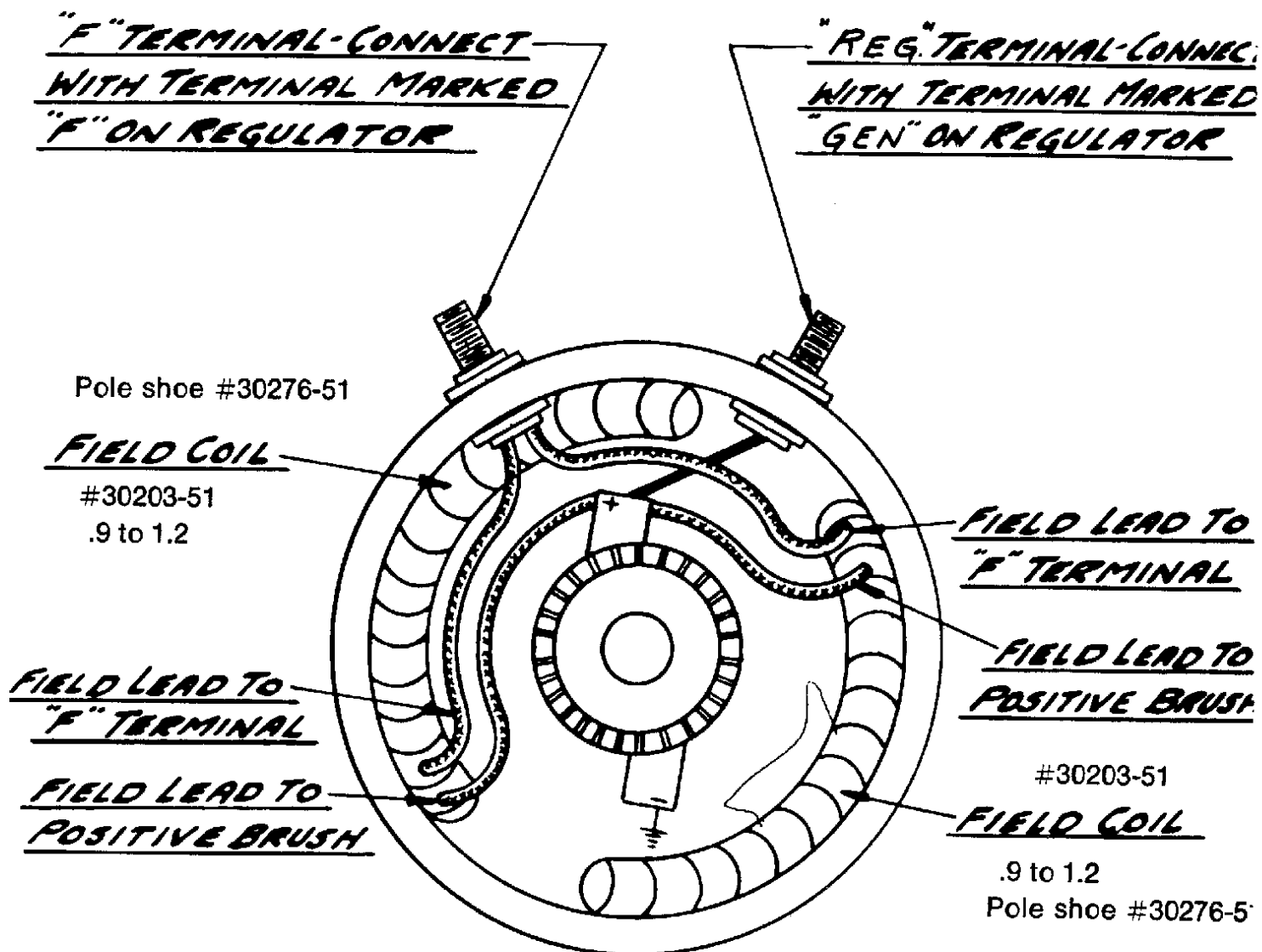

MODEL 51-1952 AND LATER TWO BRUSH FAN COOLED (RADIO)  
GENERATOR-USED WITH CURRENT AND VOLTAGE  
REGULATOR, PART NUMBER 74511-51A

MODEL 52K - K AND KH TWO BRUSH GENERATOR-  
USED WITH VOLTAGE REGULATOR PART NUMBER 74510-47

Model 51  
For K generator: .9 to 1.1 amp  
.9 to 1.1 amp  
Coil number 30202-52  
Shoe #30276-51

Peak at 3,000 to 3100 rpm = 42 mph  
 11 to 13 amp @ 42  
 4 to 8 amp @ 80  
 To change to two brush, wire 121G and install  
 voltage regulator.

POSITIVE BRUSH-HOLDER IS  
 BOLTED TO RELAY POST

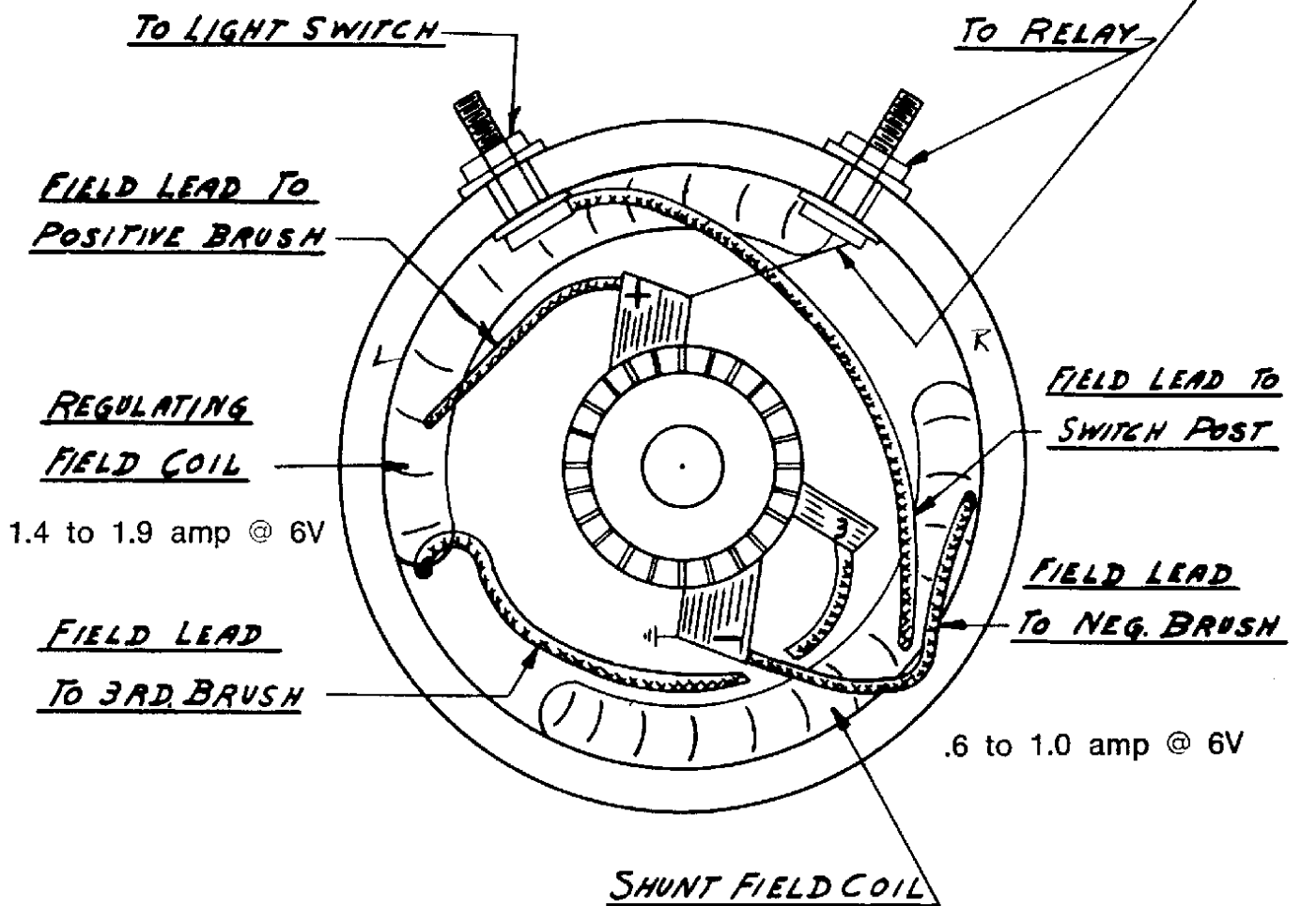

Same pole shoe as late radio generator. Model 51.

MODEL 32E STANDARD GENERATOR-1932 TO EARLY  
 1952 TWINS EXCEPT K AND KH MODELS

POSITIVE BRUSH-HOLDER IS BOLTED TO RELAY POST

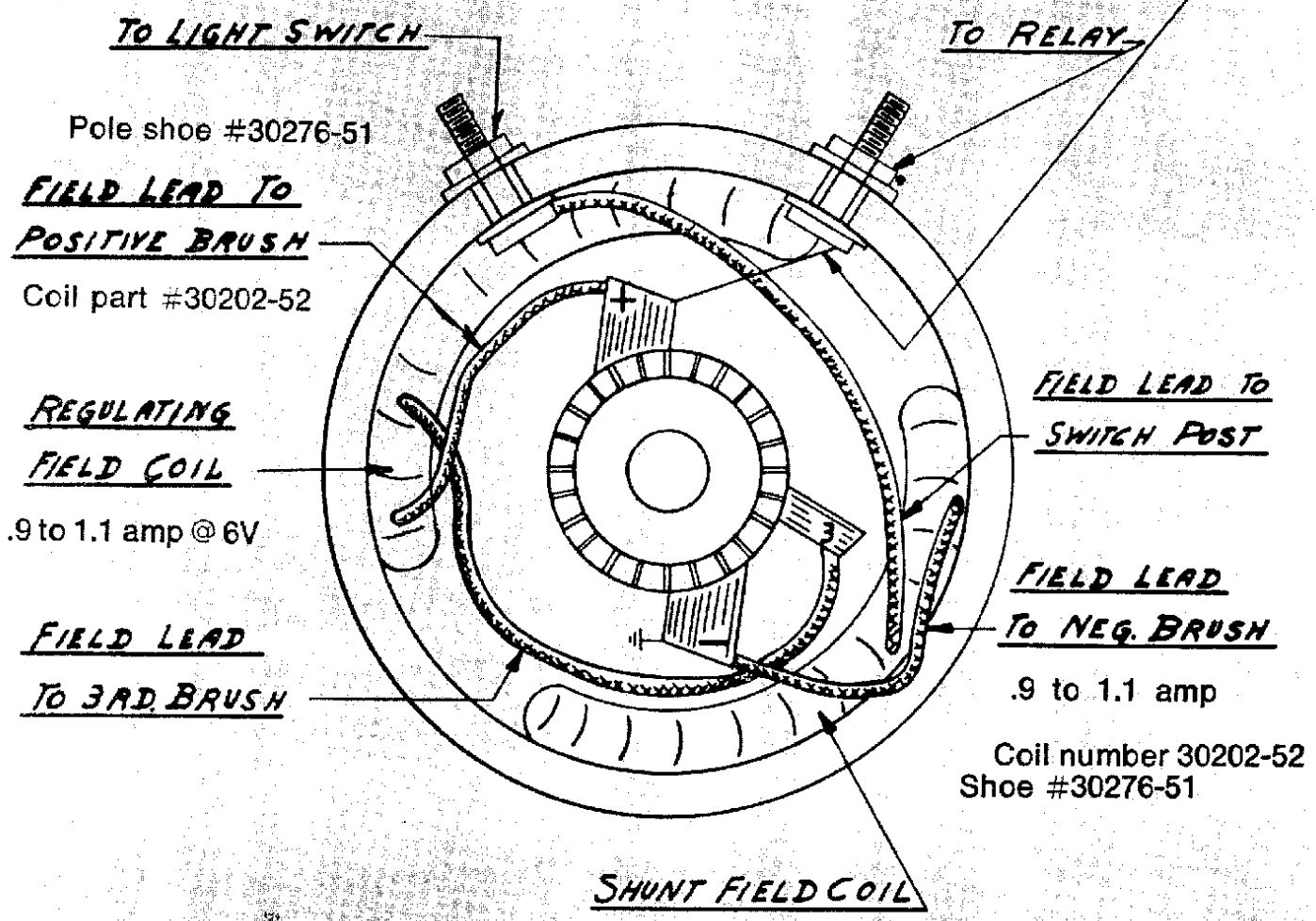

MODEL 52 STANDARD GENERATOR LATE 1952  
AND LATER TWINS EXCEPT K AND KH MODELS

## CIRCUIT BREAKER

### DESCRIPTION

The ignition system has two circuits, the primary circuit and the secondary circuit. The primary circuit consists of the battery, switch, primary coil, breaker points, condenser and associated wiring. The secondary circuit consists of the secondary coil, the spark plugs and associated wiring.

The circuit breaker has two functions. First, the breaker cam and contact points open and close the low tension circuit between the battery and ignition coil causing the coil to produce high voltage discharge to the spark plugs. Second, the circuit breaker times discharge for proper engine firing.

The following three types of circuit breakers are in use:

#### SINGLE CONTACT POINT CIRCUIT BREAKER WITH MANUAL ADVANCE (Fig. 5F-1).

The breaker points are operated by a cam with a narrow and wide lobe. The narrow lobe times the front cylinder and the wide lobe times the rear cylinder. A single ignition coil fires both spark plugs at the same time, but one spark occurs in the exhaust stroke of one cylinder and the other spark fires the combustible gases in the other cylinder to produce the power stroke. Timing is advanced or retarded by manual rotation of circuit breaker base in relation to cam.

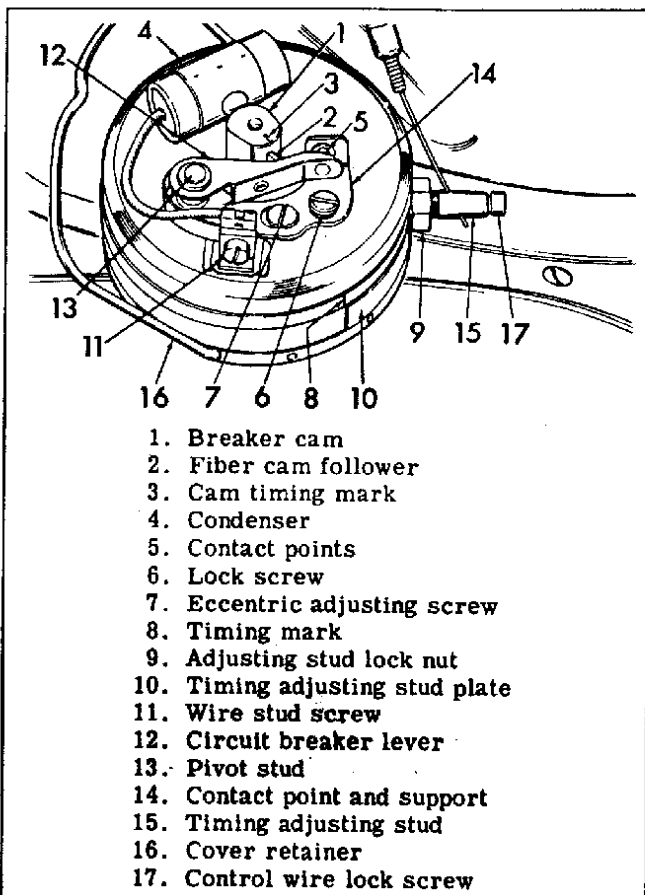
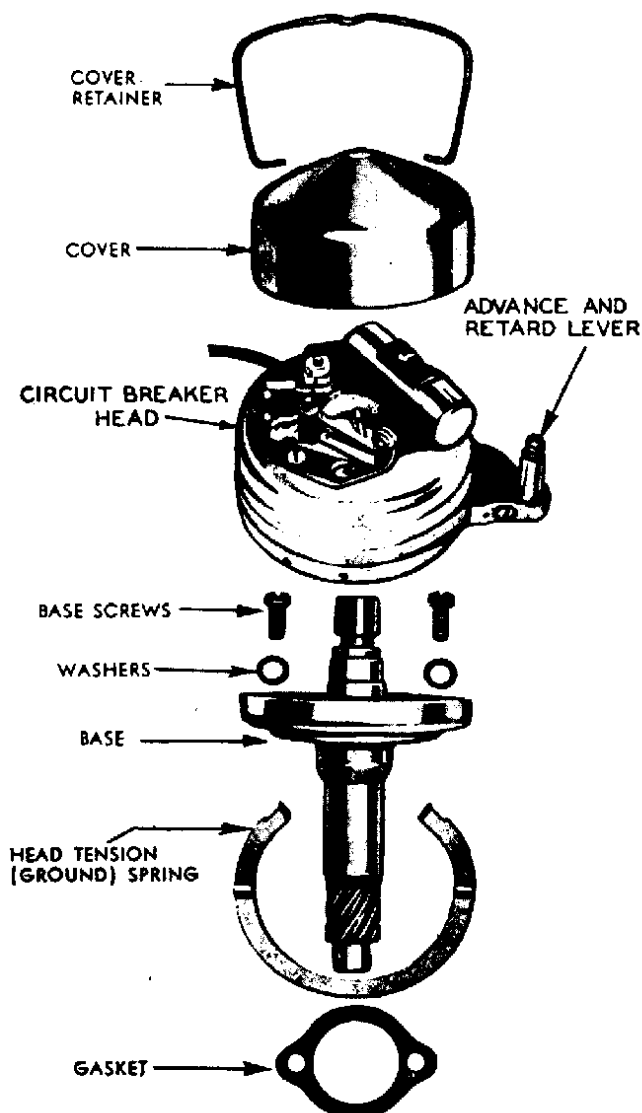

Figure 5F-1. Single Contact Point Circuit Breaker - Manual Advance

### MEMORANDA

#### DOUBLE CONTACT POINT CIRCUIT BREAKER (Fig. 5F-1B).

Ignition spark is produced by operation of separate circuit breaker contact points and ignition coils for each spark plug. The breaking of each set of breaker points by a single-lobe cam on the timer shaft determines the spark timing. The single-lobe cam opens the breaker points, individually firing alternate cylinders every crankshaft revolution.



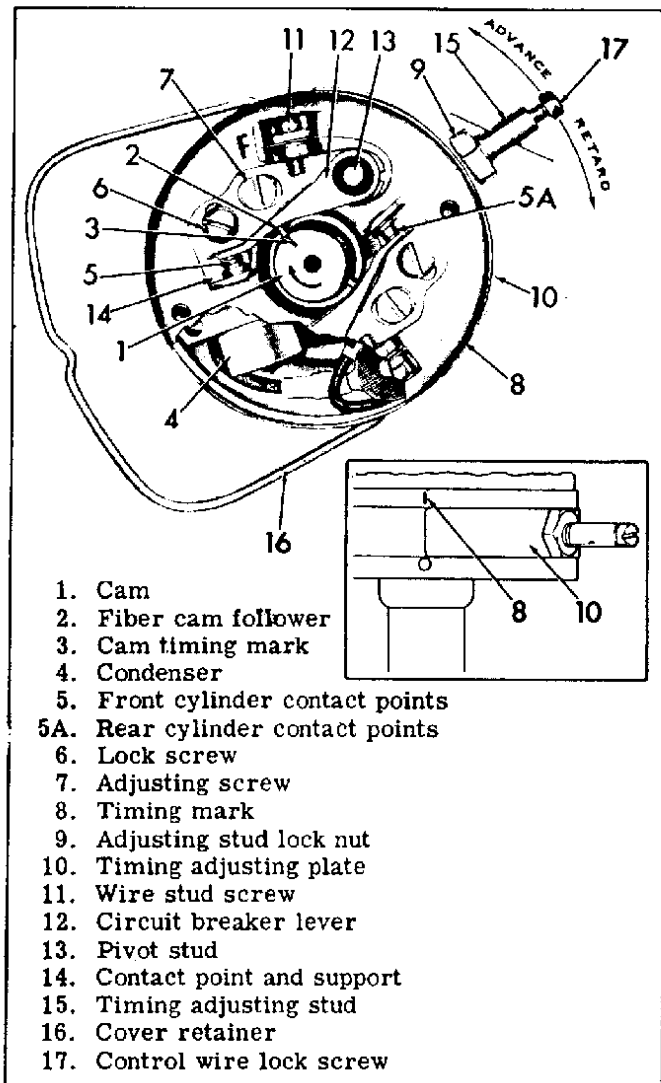

Figure 5F-1B. Double Contact Point Circuit Breaker

### OPERATION

In tracing the current through the ignition system the initial current comes from the battery. The current flows from the battery through the primary coil to ground and back to the battery while the points are closed. When the cam opens the points, the circuit is broken so that a high voltage surge is produced from ignition coil primary to secondary. This voltage will cause a spark to jump the air gap of the plugs.

The condenser is connected to the circuit breaker points and functions to produce a quick collapse of the magnetic field in the coil so that high voltage will be produced. In doing this, the condenser acts to prevent current from continuing to flow across the contact points after points open.

The engine must be timed to fire at the proper point before top dead center on the compression stroke of each cylinder. This procedure is covered under subsequent headings.

### TROUBLE SHOOTING

Disengage spark plug cable and insert a metal rod, screw or nail into each spark plug cable. Arrange cable end so tip of inserted metal object is 1/4" away from cylinder head. Turn on the ignition, break the points by hand. See if a "hot" or "blue" spark is obtained. If not, it is an indication of a weak coil, dead battery, broken or loose wires, etc. Arcing of the points and hard starting indicates a faulty condenser.

### ADJUSTING CIRCUIT BREAKER POINTS

#### NOTE

Refer to either Fig. 5F-1, 5F-1A or 5F-1B corresponding to circuit breaker used.

Circuit breaker point contacts should be checked for gap and surface condition initially at 1,500 miles and every 2,000 miles thereafter. Point contacts that have undergone considerable use, may not appear bright and smooth. However, this should not be interpreted as meaning points are worn out. Circuit breaker points that are burned or pitted should be dressed or renewed as described in "Inspection and Replacement of Parts."

**SINGLE CONTACT POINT CIRCUIT BREAKER.** Check the gap between the contact points with a feeler gage (wire preferred). Point gap should be exactly .022 in. when the lever fiber (2) is on the highest point of cam (1). Incorrect point gap spacing affects ignition timing. To adjust the points, loosen lock screw (6) and move the eccentric adjusting screw (7) to provide correct contact point gap. Retighten lock screw (6) and again check the gap to be sure it remains correct.

**DOUBLE CONTACT POINT CIRCUIT BREAKER.** On double circuit breaker (Fig 5F-1B) adjust front cylinder contact points (5) (marked "F" on base) to .022 in. gap according to above procedure. Then adjust rear cylinder contact points (5A) to .022 in. gap in similar manner.

**IMPORTANT:** Check ignition timing whenever double circuit breaker points are adjusted since any change in rear contact point gap affects ignition timing.

### CHECKING AND ADJUSTING IGNITION TIMING

#### MANUAL ADVANCE CIRCUIT BREAKERS.

#### NOTE

Refer to either Fig. 5F-1 or 5F-1B corresponding to single or double circuit breaker.

Remove spark plugs to permit engine to turn easily. Remove screw plug from timing inspection hole in left side of crankcase. Telescope front push rod cover so that opening and closing of valve can be ob-

served. Remove circuit breaker cover and set circuit breaker point gap as described in "Adjusting Circuit Breaker Points."

Turn engine in direction in which it runs until front piston is on compression stroke (just after front intake valve closes), and continue turning engine very slowly (less than 1/2 revolution) until timing mark for front cylinder on flywheel is aligned in inspection hole, as shown in Fig. 5F-3. Make sure timing mark (8) on circuit breaker base aligns with end of timing adjusting plate (10).

Rotate circuit breaker head counterclockwise against stop (fully advanced position).

Timing mark (3) on cam lobe should now align with circuit breaker arm fiber cam follower (2). If it does not, but is only slightly out of alignment, loosen timing adjusting stud lock nut (9) and shift circuit breaker head to attain alignment. Timing mark (8) will no longer line up exactly with edge of plate (10). Be sure to securely retighten lock nut. Remember that circuit breaker must be fully advanced when checking alignment of timing mark with fiber cam follower.

#### 1. SINGLE CONTACT POINT CIRCUIT BREAKER.

Use a test lamp to determine when point contacts open as follows: Connect one test lamp wire to coil wire (12, Fig. 5F-2) at spark coil terminal. Connect the other test lamp wire to the battery positive terminal. Ground battery negative terminal to engine. With points closed, lamp will light, and points open, lamp will be out.

With circuit breaker fully advanced against its stop and flywheel marks correctly positioned as shown in Fig. 5F-3, contact points should just begin to open, "light off." The instant direction is reversed (spark retarded) from full advance stop position, points should begin to close, "light on."

If the contact points remain closed, "light on", in the fully advanced position, timing is late. Loosen adjusting stud lock nut (9, Fig. 5F-1) and shift circuit breaker base counterclockwise until contact points just begin to open (timing light just flickers or goes off) in fully advanced position.

If the contact points begin to open, "light off", before circuit breaker is in fully advanced position, timing is early. Loosen adjusting stud lock nut (9, Fig. 5F-1) and shift circuit breaker base clockwise until contact points just begin to open, "light off", in fully advanced position.

Retighten lock nut (9) then move circuit breaker from retard to advance to see that points will just open when the circuit breaker reaches the advance stop. Be sure to keep flywheel mark correctly positioned during the entire procedure.

**NOTE:** Timing ignition for front cylinder automatically times ignition for rear cylinder.

**CHECKING TIMING.** Install circuit breaker cover (1, Fig. 5F-2), turn engine in direction in which it runs until front piston is on compression stroke. Continue to turn engine very slowly until points just begin to open, "light off." Flywheel mark should be correctly located in inspection hole as shown in Fig. 5F-3.

If timing mark is forward of correct position as shown in Fig. 5F-3, timing is late. If timing mark is to the rear of correct position as shown in Fig. 5F-3, timing is early. In either case, re-adjust timing as previously described.

#### 2. DOUBLE CONTACT POINT CIRCUIT BREAKER

**TIMING FRONT CYLINDER.** Connect one test lamp wire to circuit breaker yellow wire (12A, Fig. 5F-2) (front spark coil terminal), and the other wire to the battery positive terminal. Ground battery negative terminal to engine. Time front cylinder breaker points (marked "F" on circuit breaker base) with flywheel timing mark for front cylinder aligned in inspection hole as shown in Fig. 5F-3. Same as for single contact point manual advance circuit breaker.

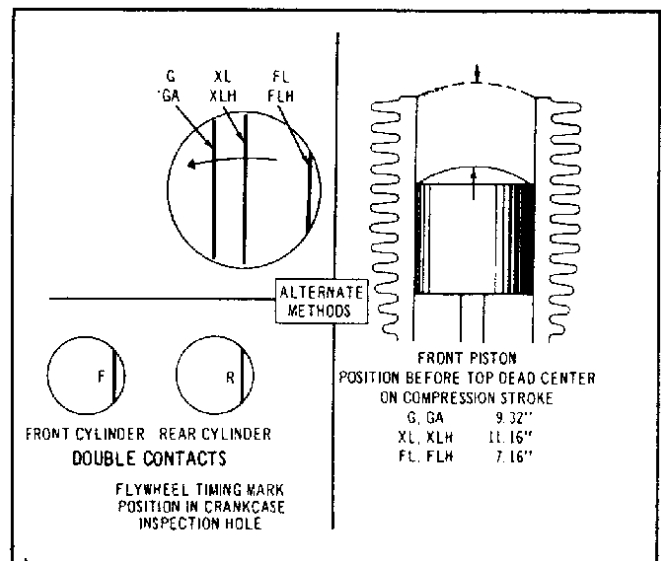

Figure 5F-3. Ignition Timing - Schematic - Manual Advance Circuit Breaker

**TIMING REAR CYLINDER.** Connect one test lamp wire to circuit breaker black wire (12A, Fig. 5F-2) (rear spark coil terminal) and the other wire to the battery positive terminal. Ground battery negative terminal to engine.

Fully advance circuit breaker.

Turn engine flywheel shaft in direction in which it runs until the mark on the cam approaches the cam follower fiber on the rear cylinder breaker points.

Continue rotating engine very carefully in same direction until timing mark for rear cylinder (marked "R" on flywheel), is aligned in inspection hole as shown in Fig. 5F-3.



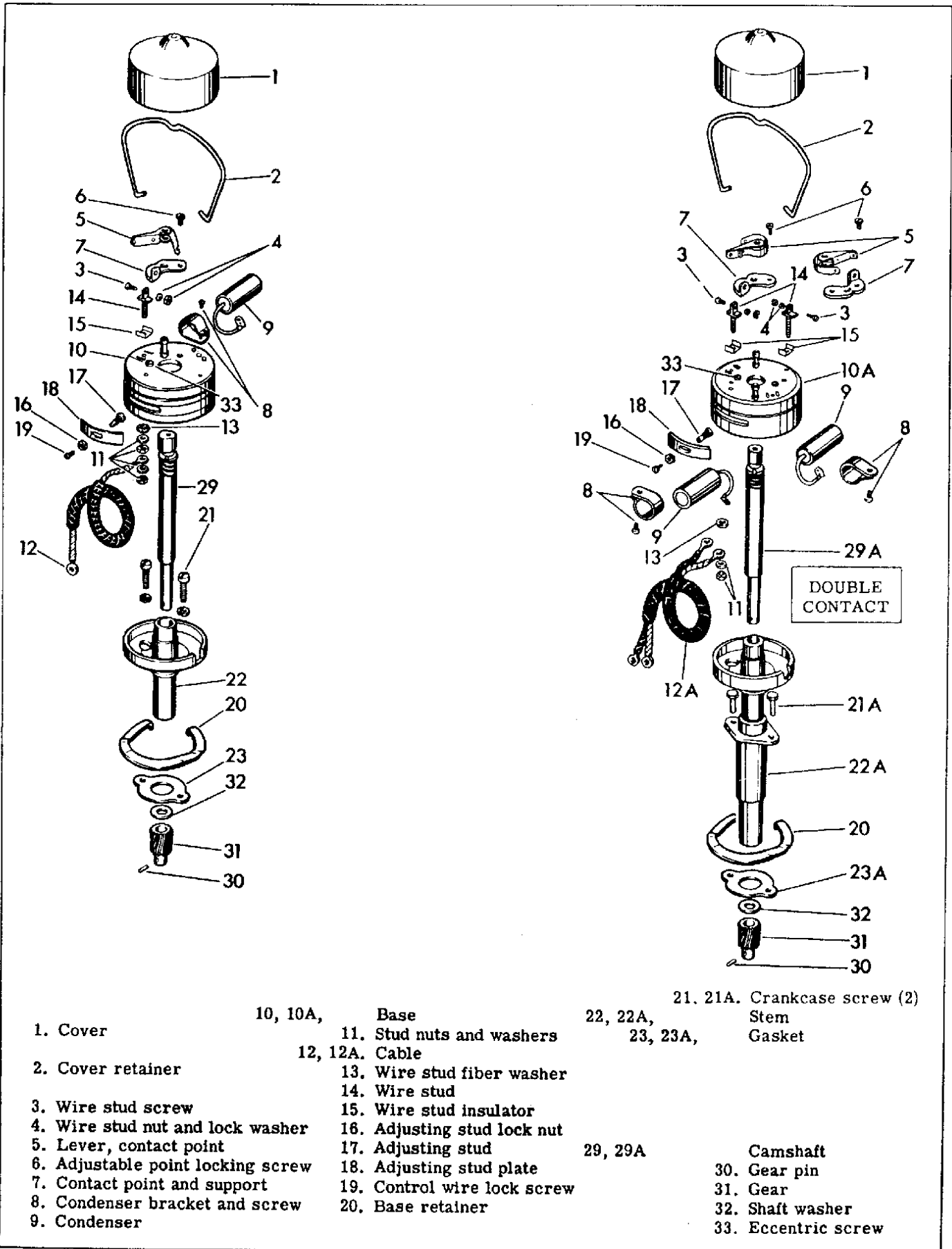
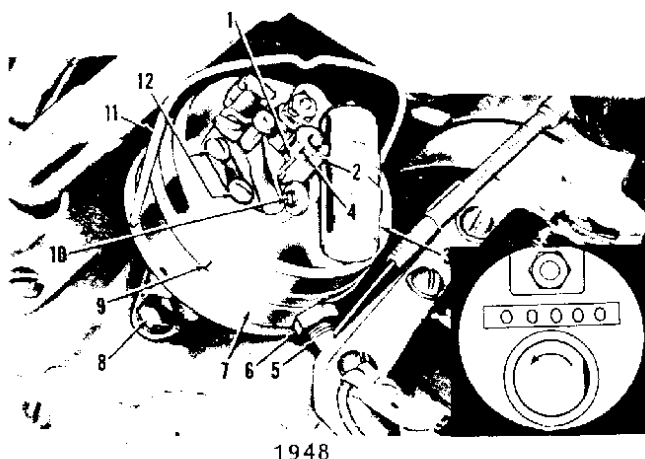

Figure 5F-2. Circuit Breakers - Exploded View



- |                           |                                |
|---------------------------|--------------------------------|
| 1. Fiber Cam Follower     | 7. Timing Adjusting Stud Plate |
| 2. Breaker Cam            | 8. Attaching Cap Screw (2)     |
| 3. Condenser              | 9. Timing Mark                 |
| 4. Cam Timing Mark        | 10. Contact Points             |
| 5. Timing Adjusting Stud  | 11. Cover Retainer             |
| 6. Adjusting Stud Locknut | 12. Lock Screws                |

Figure 7 - Circuit Breaker

#### ADJUSTMENT OF CIRCUIT BREAKER POINTS (See figure 7.)

Check the contact point gap (10) with a feeler gage. If it is not exactly 0.022-in., when the cam follower (1) is on one of the high points of the cam (2), adjustment is necessary. Incorrect gap spacing affects ignition timing. To adjust, loosen the two lock screws (12) and move the adjustable contact point to provide a contact point gap of exactly 0.022-in. Retighten the lock screws and again check the gap to make sure that it remains correct.

Flywheel timing mark: O.H.V. Engine, at rear edge of inspection hole in left crankcase.

Arrow indicates direction in which engine runs.

Contact point gap. Gap fully open (breaker lever fibre on highest point of cam) should be .022". Wrong gap affects time of ignition.

mark on breaker cam (registers with breaker lever fibre), and mark on circuit breaker head aligned with outer edge of timing adjusting stud plate indicates original factory timing.

Narrow cam times front cylinder; wide cam times rear cylinder. Cam should be lubricated occasionally with a very light application of grease.

After loosening timing stud lock nut, circuit breaker head can be shifted to adjust timing. (Not illustrated.)

Advance and retard lever not used. Timing adjusting stud controls movement of circuit breaker head; counter-clockwise position is advanced clockwise position is retarded.

## 1948 OHV Models

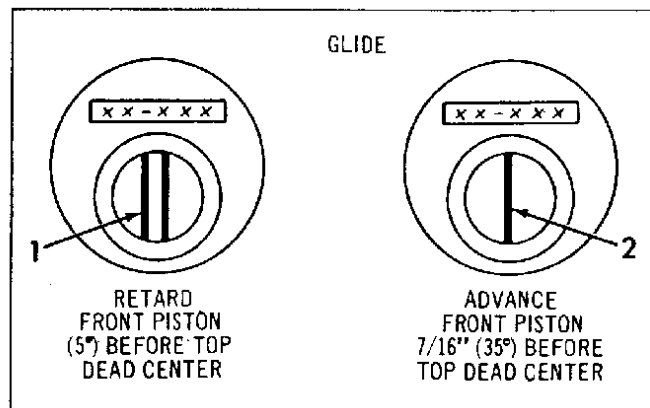

With circuit breaker fully advanced against its stop and flywheel timing mark for rear cylinder correctly positioned as shown in Fig. 5F-3, contact points should just begin to open, "light off." The instant direction is reversed (spark retarded from full advance position), points should begin to close, "light on."

If contact points remain closed "light on" in the fully advanced position, timing is late - point contacts set too close together.

If contact points begin to open "light off" before circuit breaker is in fully advanced position, timing is early - point contacts set too far apart.

To correct rear cylinder timing, the breaker points must be readjusted so contact points just begin to open (timing light just flickers or goes off) when circuit breaker is fully advanced.

**NOTE:** This will result in a different point contact opening than original setting of .022 in.

Check the rear cylinder timing with timer cover installed, using same procedure as given in preceding paragraph heading, "Checking Timing," but using rear cylinder breaker points and rear cylinder flywheel timing mark.

**NOTE:** If engine is in chassis, test lamp can be connected to circuit breaker wire and engine (ground). With ignition turned on, lamp will light with points open and go off with points closed, exactly opposite from battery hookup previously described.

#### BREAKER POINT TENSION

13 to 15 ozs. - H-D

14 to 18 ozs. - Delco Remy

### REMOVING CIRCUIT BREAKER (Fig. 5F-2)

Thoroughly clean area around circuit breaker and blow all loose dirt from crankcase with compressed air, and proceed as follows: On manual advance types, disconnect spark control wire from circuit breaker adjusting stud (17). Remove circuit breaker cover (1) and unlatch cover retainer (2) from holes in base (10 or 10A). On automatic advance type, remove screw and lockwasher (2A) to remove circuit breaker cover (1B).

### GLIDE MODEL

Remove the front cylinder head from the engine to provide sufficient clearance for removal of circuit breaker assembly. See Glide Cylinder Head, Section Using circuit breaker wrench, Part 94501-56, remove two screws (21A). Shaft and housing assembly can be lifted from gear case. On manual advance types, slip base (10 or 10A) and retainer (20) from housing.

### INSPECTION AND REPLACEMENT OF PARTS (Fig. 5F-1, 5F-1A, 5F-1B and 5F-2)

Using cloth with clean white gasoline, wipe circuit breaker clean and inspect parts.

Inspect circuit breaker contact points (5 and 5A). If lever fiber (2) is badly worn, replace points. Points that are burned or pitted should be replaced or dressed with a clean, fine-cut contact point file. Do not attempt to remove all roughness nor dress point surfaces down smooth; merely remove scale or dirt. Contact point file should not be used on other metal and should not be allowed to become greasy or dirty. Never use emery cloth or sandpaper to clean points, since particles will embed themselves and cause arcing and rapid burning of points.

Circuit breaker points should be replaced, if contact point pressure is not within prescribed limits of 14 to 18 oz. Check pressure with a spring gauge. The scale should be hooked to the breaker lever at an angle of 90 degrees with the point surface and reading taken just as points break. Excessive pressure causes rapid wear of fiber block, cam, and contact point. Insufficient pressure will permit high speed point bounce which will, in turn, cause arcing and burning of the points and missing of the engine.

Point faces must seat squarely against each other. If bent, square up by bending contact plate.

To replace a set of circuit breaker points, loosen screw (11) and slip condenser wire and connection from screw. Lift circuit breaker lever (12) from screw (11) and pivot stud (13). Remove screw (6) and circuit breaker contact point and support (14). Install new points in reverse order of disassembly. Position circuit breaker lever (12), lever notch registered with screw (11), between brass washer and condenser wire end. Be sure point faces seat squarely against each other. Adjust point gap as previously described in "Adjusting Circuit Breaker Points."

Lubricate breaker cam with a trace of grease when points are replaced or every 5000 miles. Also remove cam and lubricate shaft with very light grease Delco Remy No. 1960954 or equivalent. Replace cam in correct position.

### CIRCUIT BREAKER

Check circuit breaker advance flyweight action by moving cam in direction required to advance weights to their fully extended position. Then release the cam and see if springs return to the fully retarded position. Correct causes for faulty action by cleaning and lubricating shaft, cam and flyweights and re-

placing weak springs.

Be extremely careful to avoid excessive lubrication. If too much grease is used, the excess is apt to get on the contact points and cause them to burn.

For maximum operating efficiency it is recommended practice to replace circuit breaker points when pitted, burned or worn excessively.

The condenser (4) is a relatively long life part and will not require frequent replacement. However, if the condenser is suspected of being defective simply replace with a proven new condenser and note whether engine performance is improved. A condenser that is defective will have either an open or short circuit. An open circuit will be evident by excessive arcing at breaker contact points and a shorted circuit will have no noticeable spark at the contact points.

Examine the circuit breaker base pivot stud (13) for wear or damaged condition. Try circuit breaker base (10, 10A or 10B) Fig. 5F-2 on stem, (22, 22A, 22B or 22C) for free turning, but not loose fit. If base has too much clearance on stem, the circuit breaker point gap will vary as the base is shifted for spark control. If base is found excessively worn or damaged in any way, renew it.

Examine the coil to circuit breaker low tension wire (12 or 12A, Fig. 5F-2) for brittle or cracked insulation and broken strands and replace if defective. Inspect circuit breaker wire stud insulator (15) and fiber washer (13) for brittle or cracked condition. Unless inspection shows insulation defective, it is not necessary to remove stud, insulator and washers.

Examine cam advance mechanism on automatic advance circuit breakers to see that flyweights (26) move outward freely and springs (27) return them inward against stops. Check for looseness of cam (24) on spindle (29B or 29C) and wear on sides of flyweight (26) ears which engage slots in cam. Check springs (27) and replace if stretched or distorted. To disassemble mechanism pry clips (25) from grooves in pivot pins on stem plate (29B or 29C). Inspect teeth or worm gear (31) for excessive wear and damage. Check the amount of end play and side play of shaft (29, 29A, 29B or 29C) in stem. End play in excess of .008 in. or excessive side play of shaft in stem bushings will affect ignition timing and also allow oil from cam gear base to enter breaker assembly base to contaminate ignition points.

If renewal of shaft or stem parts is necessary remove pin (30) from gear and lift or press circuit breaker cam shaft from gear. Withdraw cam shaft from base. If bushings have excessive wear, timer stem assembly can be replaced or stem assembly can be rebushed by drifting out old bushings and installing new bushings. New bushings should require no reaming. When reassembling gear and breaker cam shaft use standard spacer washer (.062 thick), or thicker washer (.066 thick) or (.072 thick) to obtain a .001 or .007 in. shaft end play.

When assembling circuit breaker shaft in breaker stem, always secure gear and spacer washer to shaft with new steel pin riveted in place. Rotate shaft to be sure it is free in stem.

#### INSTALLING CIRCUIT BREAKER GLIDE MANUAL CIRCUIT BREAKERS

Remove spark plugs to permit engine to turn easily; remove screw plug from timing inspection hole in left side of crankcase. Telescope front push rod cover so that opening and closing of valve can be observed. Turn engine in direction in which it runs until front piston is on compression stroke (just after front intake valve closes) and continue turning engine very slowly (less than 1/2 revolution) until advance timing mark on flywheel is aligned in the inspection hole as shown in Fig. 5F-3.

Assemble circuit breaker as follows (See Fig. 5F-2):

Position circuit breaker base assembly (10 or 10A) on shaft and stem assembly (22 or 22A), wrapping wire (12 or 12A) clockwise around shaft. Install base retainer (20) over wire, retainer ends facing down and toward front cylinder. Engage cover retainer (1) with holes in base and register retainer ends in locating notches of base retainer (20).

Make sure timing mark (8, Fig. 5F-1 or 5F-1B) on circuit breaker base aligns with end of adjusting stud plate (10).

Install a new circuit breaker gasket (23 or 23A, Fig. 5F-2) using gasket sealer. Turn circuit breaker shaft counterclockwise approximately 60 degrees from position where mark on cam lobe lines up with breaker lever fiber.

Temporarily insert circuit breaker assembly into gear case, with adjusting stud pointing toward the front of motorcycle and screw holes of stem housing lined up with mounting holes in crankcase. Move circuit breaker base (10 or 10A) to fully advanced position (counterclockwise) and observe how close timing mark on cam lobe lines up with breaker lever fiber.

#### NOTE

On double contact breakers, mark on cam lobe must align with breaker lever fiber on contact points for front cylinder. This set of contact points is identified on breaker base by (F).

If fiber does not line up with cam lobe timing mark, lift circuit breaker assembly and turn shaft gear so engagement with driving gear is changed one tooth. Again check cam lobe timing mark for alignment with lever fiber. Repeat this procedure until gear engagement is attained which closely aligns cam lobe mark and lever fiber, then secure circuit breaker assembly to crankcase.

Adjust ignition timing. See previous paragraph "Checking and Adjusting Ignition Timing" in this section.

## IGNITION COIL

### DESCRIPTION

The ignition coil is a pulse transformer that transforms or steps up low battery or generator voltage to high voltage necessary to jump the electrode at the spark plug in the engine cylinder head. Internally, coil consists of primary and secondary windings with laminated iron core and sealed in waterproof insulating compound. Case cannot be taken apart or coil repaired.

### TROUBLE SHOOTING ALL MODELS

#### NOTE

Interpret references to "plug," "cable," "condenser" etc., as "plugs," "cables," "condensers" when more than one are used.

When hard starting or missing indicates a faulty ignition system, first, check condition of source of current (battery or magneto depending on model of motorcycle). If lamps light with full brilliancy and horn blows, indicating current source is in at least fair condition check, clean or replace spark plug. If this does not correct performance, inspect circuit breaker points and install new condenser. If condition persists, try a new ignition coil. (In the case where two separate coils are installed determine which is believed to be faulty.)

Temporarily substitute a new ignition coil by attaching it at any convenient point near old coil (coil will function without being securely grounded). Transfer terminal wires to new coil according to the information given in the wiring diagrams pertaining to the model being worked on. Attach new coil cable to the spark plug. If ignition trouble is eliminated by the temporary installation of new coil, carefully inspect old coil for damaged cables and insulation. The insulation on cables (and on some models the coil itself) may be cracked or otherwise damaged allowing high tension current to short to metal parts. This is most noticeable in wet weather or when motorcycle has been washed.

Replacing plug cable is the only repair that can be made to an ignition coil. If this does not correct faulty coil performance, coil is defective.

Warm coil slightly to soften sealing compound so old cables may be pulled out easily, without breakage. To warm coil allow current to flow through it by turning "ON" ignition switch (circuit breaker points must be closed). Have new cables ready with ends trimmed and rounded so they will follow the holes left in sealing compound. Clip off old cable at plug end and transfer cable packing nut, (4) cable washer (3) and new cable packing washer (2) onto the new

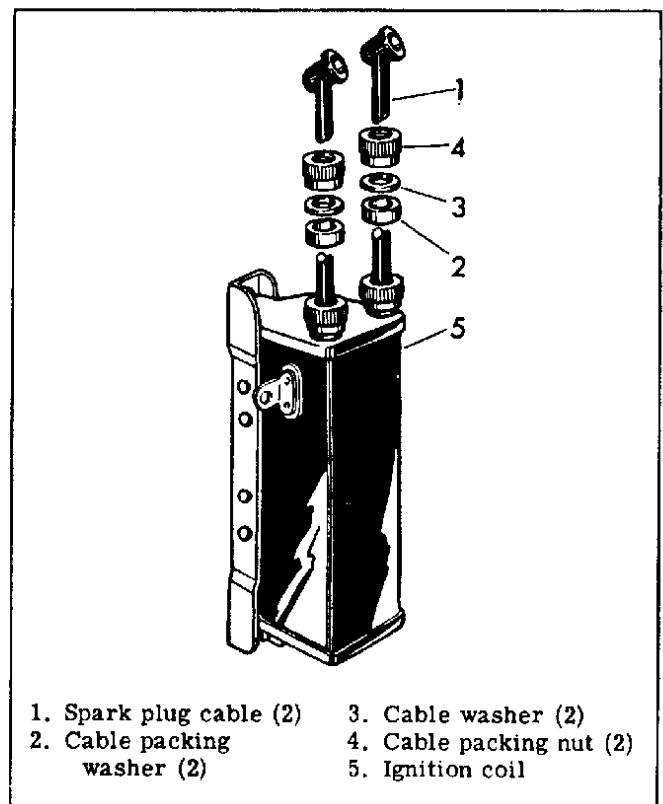

Figure 5G-2A. Ignition Coil - Glide

### H-D SPARK COILS

Draws 1.5 amperes. Current voltage output 15,000 to 18,000.

cable and dip new cable end in very light oil. Remove old cable and quickly install new cable making certain it bottoms in the coil. After cable is installed turn seal nuts down against rubber packing washers to secure and seal it.

When replacing cables do not heat coil too hot, doing so will soften sealing compound to the extent that cable holes through compound will close up as old cables are pulled out, blocking the insertion of new cables. If this happens, allow coil to cool and then form new cable holes using a piece of tubing with saw teeth filed in one end. Tubing should be of slightly larger diameter than cable. Holes through compound must be open so cables can be inserted all the way to their seats, where they contact high tension winding terminals; otherwise there is a gap in the high tension circuit and coil will not function.

## SPARK PLUGS

### GENERAL

Harley-Davidson spark plugs (Figure 5H-1) have been designed to give maximum life and efficient combustion of fuel. They are available in various "heat ranges," each for a particular service application. Plugs are labeled with numbers 2, 3, 4, or 5 the lowest number indicating the "hottest" plug. Designations 3-4 and 7 are special-purpose plugs.

For normal service, the spark plug as recommended in motorcycle specifications, Section 1-A, should be used on a particular model. However, for special service conditions, a "colder" or "hotter" plug may be desired. The number 2 plug, for example, may be best for slow speed operation while the number 5 plug would be best for the higher speeds of highway travel or special high-speed operation. The intermediate plugs (3 and 4) are designed for use in motorcycles with moderate or average service applications. It is not uncommon for best results to be obtained with plugs of different heat ranges in front and rear cylinders, with the front usually the colder.

### REMOVING SPARK PLUGS

Disconnect wires from plugs, connection is simple snap-on type. Use a deep socket wrench or special spark plug wrench to loosen plugs. Blow away all dirt from plug base with compressed air before removing plug.

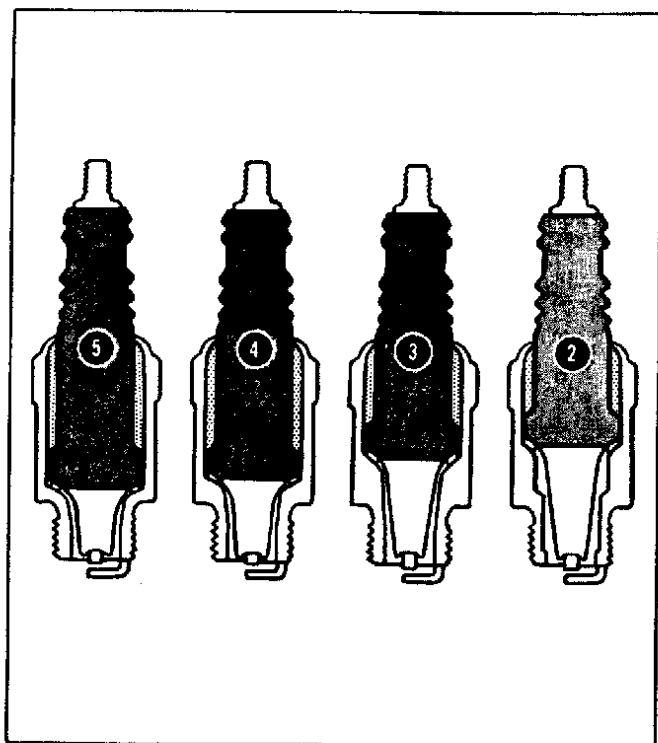

Figure 5H-1. Spark Plug Heat Range

### CLEANING, INSPECTION AND REPAIR (Figure 5H-2)

Examine plugs as soon as they have been removed. The deposits on the plug base are an indication of the correctness of the plug heat range and efficiency, as well as a guide to the general condition of rings, valves, carburetor and ignition system.

A wet, black and shiny deposit on plug base, electrodes and ceramic insulator tip (A) indicates an oil fouled plug. The condition is caused by worn rings and pistons, loose valves, weak battery, faulty ignition wires, circuit breaker trouble, weak coil or a cold plug.

A dry, fluffy or sooty black deposit (B) indicates plug is gas fouling, a result of a too rich carburetor air-fuel mixture, long periods of engine idling or a cold plug.

An overheated plug (C) can be identified by a light brown, dry, glassy looking deposit. This condition may be accompanied by cracks in the insulator tip and is caused by too lean an air-fuel mixture, a hot running engine, valves not seating, improper ignition timing or too hot a plug for the service. The oxide deposit on the spark plug is a conductor when hot. It will cause plug to misfire, especially at high speed.

A plug with a rusty brown to tan powdery deposit (D) indicates a balanced ignition and combustion condi-

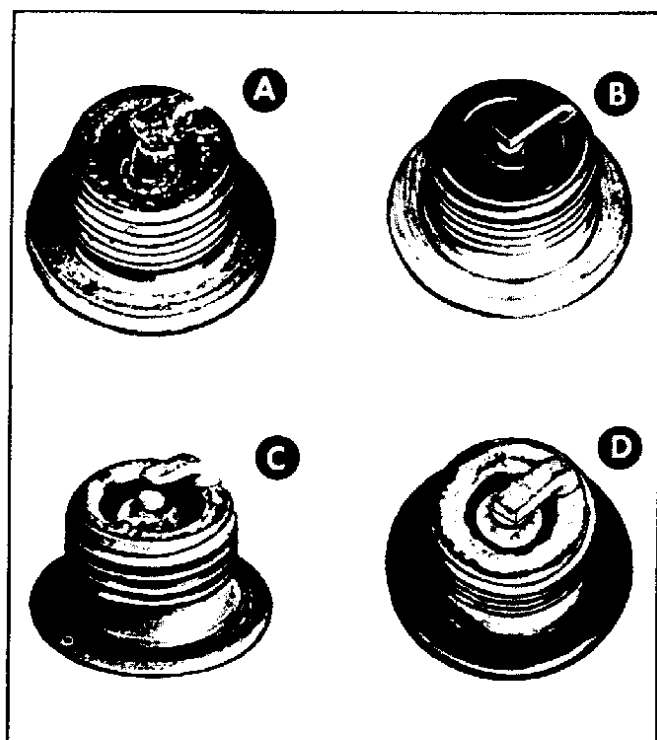

Figure 5H-2. Type of Plug Base Deposits

## Notes

tion. With leaded gasolines the deposits may be white or yellow. In either case, ignition functions through the deposits if only light and the deposits should be cleaned off at regular intervals to keep them from building up.

When spark plug electrodes have become eroded away (C) to the point where gap setting is difficult or impossible, the plug should be replaced. Plugs with cracked insulator should also be discarded.

Clean plugs with a sand blast cleaner. Rotate plug top while applying sand blast to clean insulator and electrodes. Cleaning time should be carefully limited to just what is necessary to clean deposits from insulator nose. Prolonged use of abrasive blast will wear away insulator. Normally three to five seconds of sand blasting are sufficient. Never use metal instruments to remove deposits from plugs.

### SETTING SPARK GAP

Before setting spark gap on used plugs, pass a thin point file (or nail file) between electrodes to produce flat, parallel surfaces to facilitate accurate gauging.

Use only a wire type gauge. Bend the outside or grounded electrode so only a slight drag on the gauge is felt when passing it between electrodes. Never make adjustments by bending the center electrode. Set gap on plugs as shown under Engine Specifications, Section 3A.

### TESTING SPARK PLUGS

Check the sparking ability of a cleaned and re-gapped plug on a sparking comparator if possible. An inability to withstand rapid firing under cylinder compression conditions can be discovered.

### INSTALLING SPARK PLUGS

Before turning spark plugs into cylinder heads, check condition of threads in head and on plug. Soften deposits in cylinder head with penetrating oil and clean out with tap or old plug.

Install new spark plug gasket and turn plug down finger tight. Tighten to 15 pounds with torque wrench or 3/4 of a turn.

Check and adjust engine idle speed and mixture setting after installing new set of plugs if necessary.

# SHOP DATA

## SPECIFICATIONS FOR SETTING DELCO-REMY REGULATORS USED ON HARLEY-DAVIDSON MOTORCYCLES

All electrical checks and adjustments must be made with regulator at operating temperature. This requires about 15 minutes operation with generator charging approximately 5 amperes.

Delco-Remy number 1118224 Harley-Davidson part number 8375-41 current and voltage regulator - original equipment up to 1948 with 2-brush radio generators, not fan-cooled. (Regulator 1118224 no longer available on parts order. Superseded by 1118327.)

Voltage regulator air gap	.070 in.
Current regulator air gap	.080 in.
Cutout relay air gap	.020 in.
Cutout relay point opening	.020 in.

Cutout relay closing voltage	Voltage regulator setting (volts)	Current regulator setting (amp.)
6.6	7.5	13.0

Delco-Remy number 1118327 Harley-Davidson part number 8375-41 current and voltage regulator - this regulator was never used as original equipment but supersedes Delco-Remy regulator 1118224 for replacement requirements.

Voltage regulator air gap	.075 in.
Current regulator air gap	.075 in.
Cutout relay air gap	.020 in.
Cutout relay point opening	.020 in.

Cutout relay closing voltage	Voltage regulator setting (volts)	Current regulator setting (amp.)
6.6	7.5	13.0

Delco-Remy number 1118388 Harley-Davidson part number 74511-51 current and voltage regulator - used with 2-brush fan-cooled radio generator equipped 1951 model motorcycles.

Voltage regulator air gap	.075 in.
Current regulator air gap	.075 in.
Cutout relay air gap	.020 in.
Cutout relay point opening	.020 in.

Cutout relay closing voltage	Voltage regulator setting (volts)	Current regulator setting (amp.)
6.6	7.5	18.0



Delco-Remy number 283 Harley-Davidson part number 31700-47 Voltage regulator only - used with all model 125; 1949 - 3-brush fan-cooled radio generator; and 1950 2-brush fan-cooled radio generator. Regulator No. 283 no longer available on parts order. Superseded by regulator No. 307

Voltage regulator air gap	.070 in.
Cutout relay air gap	.020 in.
Cutout relay point opening	.020 in.

Cutout relay	Voltage regulator
closing voltage	setting (volts)
6.5	7.0 - 7.7

When used on model 125 set for 7.0 volts. When used with fan-cooled generator set for 7.7 volts.

Delco-Remy number 307 Harley-Davidson part number 74510-47 - voltage regulator only - this regulator supersedes, and is interchangeable with Delco-Remy regulator No. 283.

Voltage regulator air gap	.075 in.
Cutout relay air gap	.020 in.
Cutout relay point opening	.020 in.

Cutout relay	Voltage regulator
closing voltage	setting (volts)
6.5	7.0 - 7.7

When used on model 125 set regulator for 7.0 volts. When used with fan-cooled radio generator set for 7.7 volts.

Applying to 2-brush fan-cooled radio generator on 1950 model motorcycles; also applying to 1949 model motorcycles where original 3-brush fan-cooled radio generator has been converted to 2-brush generator, it is recommended that when replacement of original equipment voltage regulator Delco-Remy No. 283 or No. 307 may be required, current and voltage regulator Delco-Remy No. 1118388, Harley-Davidson part number 74511-51 be installed.

Delco-Remy makes many different regulators, each carrying a different number stamped on regulator base or regulator mounting bracket. Many of these regulators look identical in size, shape, etc., but each different model number means there is some difference in construction or a difference in setting specifications.

It is not unusual to find that someone has replaced an original equipment regulator with one that looks like the original, but has a different number and entirely different setting that are not at all suited to a Harley-Davidson generator.

This usually results in one of two things. Either the generator output is controlled so low that battery doesn't stay charged, or generator is overheated and damaged from not enough control, and resultant excessively high output. Go by regulator numbers

Current and voltage regulator, Delco-Remy number 1118388, Harley-Davidson part number 74511-51 has been superseded by current and voltage regulator Delco-Remy number 1118707, Harley-Davidson part number 74511-51. Current regulator number 1118707 is adjusted for 20 amperes. All other specifications remain the same as for regulator number 1118388.

The "K" model motorcycle is equipped with voltage regulator, Delco-Remy number 307-Harley-Davidson part number 74510-47. Regulator is adjusted for 7.4 volts - all other specifications remain the same as given for number 307 regulator

## BATTERY

### GENERAL

The battery serves as a storage place for current used in starting the motorcycle; to operate accessories when the engine is not running; to provide additional current, when necessary, over the amount being generated. For a battery to remain in good condition, the current draw must be balanced by a current input. All Harley-Davidson batteries are three-cell, six-volt units of capacities suitable for load requirements under intended use.

### BATTERY CARE

Prompt and correct battery care determines the life span of the unit. Therefore, for a longer useful life, the battery solution level must be checked at weekly intervals. Add only pure distilled or approved water to 5/16 in. above plates and separators. Be careful not to overfill. Overfilling will result in some of the electrolyte being forced out through cap vent holes, diluting or weakening the solution strength. An overflow of battery solution will cause cables to corrode and motorcycle parts near the battery to be damaged.

Clean battery and terminals when necessary with a baking soda-water solution. Be careful to avoid getting any of the solution into the cap vent holes. When solution stops bubbling, flush off battery with clean water.

Coat terminals with grease after wires have been attached to retard corroding.

### CHARGING BATTERY

Never allow a battery to stand in a discharged condition. Start charging it at once at the recommended continuous charge rate.

To determine the amount or condition of a battery charge, check solution in each cell with a battery hydrometer. When hydrometer reading is 1.200 or less, battery is considered discharged and should be removed from motorcycle and charged at the following maximum continuous charge rate:

- 51 Ampere hour battery - 3-1/2 amperes
- 22 Ampere hour battery - 1-1/2 amperes
- 10 Ampere hour battery - 1/2 ampere

A higher battery charge rate will heat and damage the battery. For this reason, do not allow the motorcycle battery to be charged in the same line with automobile batteries. Hydrometer reading of a fully charged battery in good condition, with full strength electrolyte will be 1.270 or higher.

**A battery will not charge unless temperature is above 47° F.**

### WARNING

Hydrogen gas, formed when charging, is explosive. Avoid open flame or electrical spark near battery.

Allowing a battery to remain in a discharged condition will shorten its life. It is important that a battery be kept well charged during below freezing weather.

### RECLAIMING SULPHATED BATTERY

If a battery has been allowed to stand in a discharged condition for a period of time, the lead sulphate in the plates will crystalize and not take a charge at normal rates. Such batteries should be charged at half the specified continuous rate for twice the computed time. A longer charging time at a slower rate will many times break down the crystalline structure into active materials and restore the battery.

### CHANGING ELECTROLYTE

In normal service with average care, it is never necessary to change electrolyte for the lifetime of the battery. However, if the battery solution is spilled, diluted as a result of careless water addition, or neutralized by the addition of an alkaline substance, the battery solution may be changed and in some cases near full capacity restored.

A weak acid solution may be detected by charging the battery until all cells gas freely and the gravity has not shown a rise for three successive readings taken at hourly intervals. "Gassing" is evidenced by a bubbling action in the electrolyte that may be detected by sight or sound. Do not change electrolyte in a battery with one or more cells that fail to gas. Such a condition indicates a structural failure.

Pour solution out of charged battery and fill with water. Charge battery again until maximum specific gravity is reached. Pour out this solution and add prepared battery electrolyte to specified level and charge again for a short length of time for full capacity.

Check specific gravity and add a little water if necessary to bring solution down to desired maximum limits.

The value of changing electrolyte in a fairly old battery is questionable. By tipping over such a battery to drain the solution, the sloughed-off waste materials accumulated by repeated charging and discharging actions might be dislodged from the sediment chambers in the bottom of the battery and deposited in the separators. This material is an electrical conductor and thus may "tree" or catch in the separators and cause a short circuit.

## HORN

### GLIDE

If the horn does not blow satisfactorily, the trouble may be caused by a constricted diaphragm, loose terminal wires, or a discharged battery. Before attempting to correct horn performance by moving the adjusting screw, it is recommended procedure to trouble shoot as follows: (Fig. 5K-1 and 5K-2).

1. Check the battery for adequate current. Examine the horn trumpet (10 or 11, depending on model being worked on) and power pack (6) for misalignment with each other causing constriction of power pack diaphragm. To correct horn misalignment, loosen horn power pack support bracket (16) or (17)

and horn support bracket nut (7), and correctly align (10 or 11) and (6) with each other. Be sure the horn trumpet does not contact any part of the engine. If horn trumpet and power pack cannot be realigned, check the power pack support bracket (16) or (17) for bent condition.

2. Check to make sure horn power pack has not been tightened more than 2 to 2-1/2 turns on trumpet stem. If tightened further, trumpet stem end will obstruct operation of pack diaphragm.

3. Inspect horn wiring for damage or loose connections at the terminal points. Loose or damaged horn wires will result in inadequate voltage at the

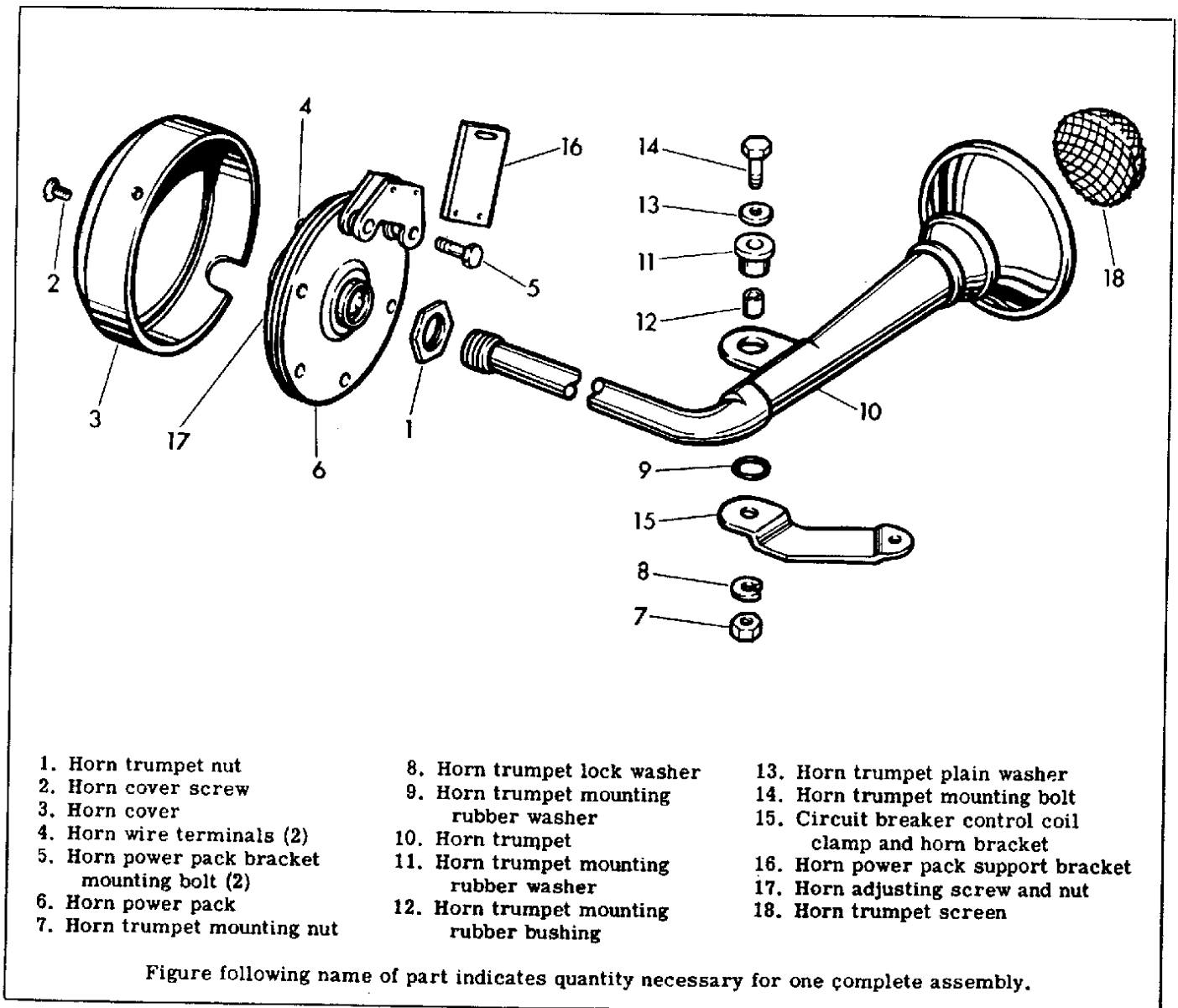

Figure 5K-1. Horn - Exploded View - Glide

power pack, causing poor volume and tonal qualities. Also, check horn button contact points for dirty or corroded condition.

4. Horn performance will be affected if dirt or water accumulates in the trumpet or horn pack diaphragm compartment. This condition will dampen action of the horn diaphragm affecting volume and tonal quality of the horn. Remove trumpet and power pack and clean out all scale and dirt. Shake out any accumulated debris from the power pack and reassemble.

#### DISASSEMBLY AND REASSEMBLY (Fig. 5K-1)

To disassemble the horn, simply follow the order of disassembly as illustrated. When installing the horn power pack to the trumpet, tighten the power pack 2 - 2-1/2 turns on the trumpet stem before tightening nut (1). Be careful to correctly position all parts as shown to insure correct alignment of trumpet and pack.

#### ADJUSTMENT

Loosen the center core jam nut with a wrench, and turn the slotted center core screw 1/2 turn counterclockwise with a screwdriver. Then adjust the Phillips head tone adjusting screw until the horn blows. Turn the center core screw clockwise until the horn rattles, and then back off screw (counterclockwise) 1/4 turn. While holding core screw in this position, tighten core screw lock nut with wrench. Readjust the Phillips head tone adjusting screw for desired tone.

If the horn fails to blow or does not blow satisfactorily, check for loose, frayed or damaged wiring leading to horn terminals, discharged battery, etc. If these steps do not correct the trouble, turn the contact point adjuster screw located back of horn until horn just gives a single click - then retard screw until best tone is obtained. If horn fails to operate after moving adjusting screw it is necessary to disassemble horn for inspection and cleaning of parts.

#### DISASSEMBLY (Fig. 5K-3) ( Early type )

Disconnect horn wires and remove horn from motorcycle. Remove three horn front bolts, lock washers and nuts (1) and remove horn front (2). Remove three horn diaphragm bolts, lock washers and nuts (3), loosen retainer (4) and horn diaphragm (5) from horn back (6).

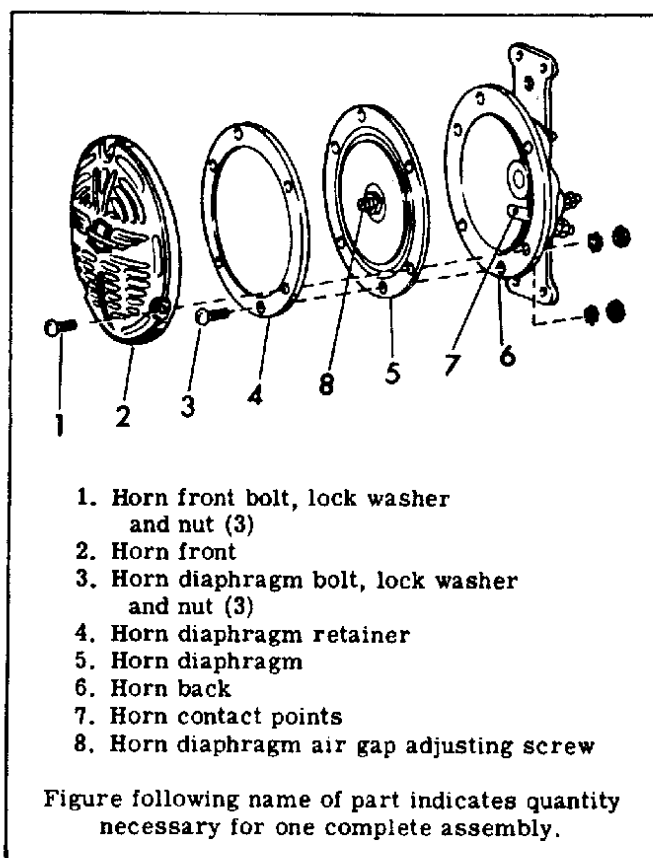

Figure 5K-3. Horn - Exploded View -

#### INSPECTION AND REPAIR

Brush all scale, rust and dirt from horn parts and blow clean with compressed air. Examine interior of horn for damaged or broken wires and cracked or damaged terminal screw bushing. Make sure contact points are clean.

Air gap adjusting screw (8) should be left as originally set by the manufacturer. However, in the event horn does not appear to operate correctly after all other possible disorders have been eliminated (includes cleaning of contact points), the air gap adjusting screw can be turned to correct tone and output of horn.

#### ASSEMBLY

Assembly is the reverse order of disassembly. Be sure to correctly align the diaphragm assembly on the horn back and to readjust the contact points after the horn is assembled.



MISCELLANEOUS

## SIDECAR

### Removing Sidecar From Motorcycle

Set motorcycle on rear stand. Disconnect brake rod from brake shaft lever. If sidecar is equipped with any lamps, disconnect the wires from their respective terminals.

Loosen ball joint lock nuts and ball joint nuts. Remove cotter pin, nut, spring and washers from frame brace upper front connection on motorcycle. Loosen the four sidecar frame brace lower clamp screws enough to allow disconnecting brace from upper front connection on motorcycle. Place blocks of suitable height under chassis to support it while disconnecting ball joint nuts from rear and front connections on motorcycle.

### Attaching Sidecar to Motorcycle

Set motorcycle on rear stand near sidecar chassis. Put a small amount of grease in each ball socket. Block up chassis so that front and rear connections are as close as possible to, and nearly of the same height as motorcycle connections. Make sure ball joint nut lock nuts are loose on ball joint nuts.

Make front connection first, then rear connection. Due to previous slight misalignment, it may be necessary to loosen rear ball socket bracket nuts and shift bracket slightly before rear connection can be made. After rear connection has been made, tighten bracket nuts securely, and insert cotter pins.

When ball joints are properly adjusted, there will be flexibility between motorcycle and sidecar chassis, but no play in joints. Tighten ball joint nut until it just bottoms; and then back off about 1/8 turn. Hold ball joint nut in this position with one wrench and tighten ball joint nut lock nut securely with another wrench. After both ball joints have been properly adjusted and locked, push motorcycle off rear stand.

Put a small amount of grease on upper front connection and attach brace to upper front connection on motorcycle. Install larger washer, spring, smaller washer and nut; turn nut on until end of connection bolt just protrudes through nut and insert cotter pin.

Adjust sidecar frame brace so motorcycle leans about 2 degrees away from sidecar. It is of prime importance that this adjustment be carefully made, as it affects steering. With adjustment correct, motorcycle will have no appreciable tendency to pull to either right or left when driven on a level highway. Tighten frame brace lower clamp screws securely.

Connect brake rod to brake shaft lever. If brake needs readjusting, see "Adjusting Brakes",

Connect any lamp wires to their respective terminals—see "Sidecar Wiring Diagrams,"

Note: If a new sidecar is to be attached to a motorcycle not previously equipped with one, follow instructions included with sidecar.

### Adjusting Brake

See "Adjusting Brakes,"

### Servicing Brake

See "Servicing Brakes,"

### Removing Wheel

See "Removing Sidecar Wheel,"

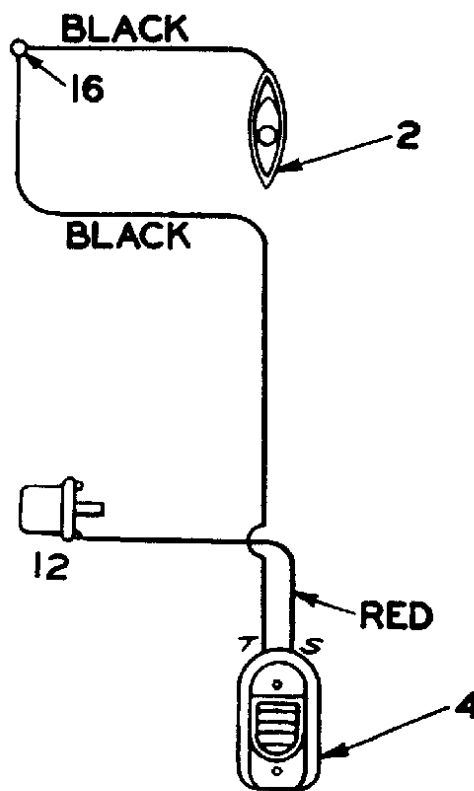

ILLUS. 154

### Wiring Diagram

#### Connections

2. MUDGUARD LAMP—Black wire from junction terminal (16).
4. TAIL AND STOP LAMP—Red wire from stop lamp switch (12); black wire from junction terminal (16).
12. STOP LAMP SWITCH (on motorcycle)—Red wire from sidecar tail and stop lamp (4).
16. JUNCTION TERMINAL (in left side of motorcycle frame under saddle)—Black wire from mudguard lamp (2); black wire from sidecar tail and stop lamp (4).

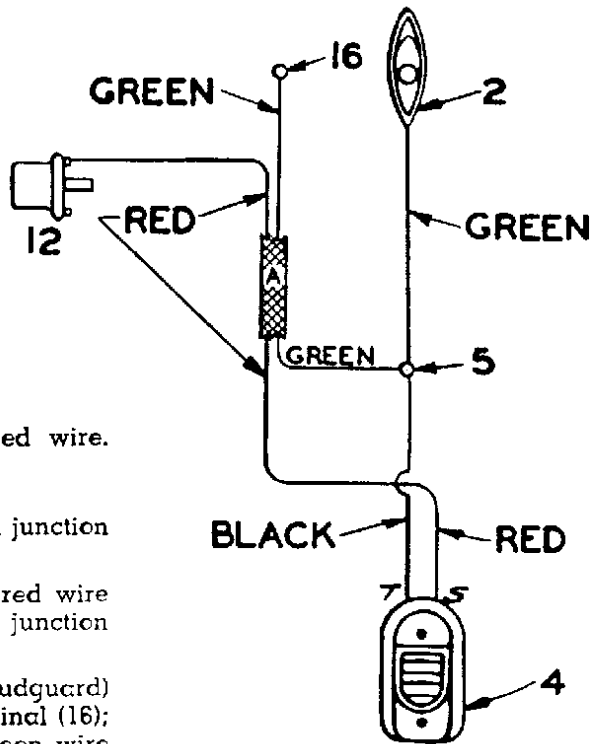

### Wiring Diagram

(Later Model Sidecar)

A. TWO WIRE CABLE—Green wire; red wire.

#### Connections

2. MUDGUARD LAMP—Green wire from junction terminal (5).

4. TAIL AND STOP LAMP—Cable "A" red wire stop lamp switch (12); black wire from junction terminal (5).

5. JUNCTION TERMINAL—(in sidecar mudguard)—Cable "A" green wire from junction terminal (16); black wire from tail and stop lamp (4); green wire from mudguard lamp (2).

12. STOP LAMP SWITCH (on motorcycle)—Cable "A" red wire from tail and stop lamp (4).

16. JUNCTION TERMINAL (in left side of motorcycle frame under saddle)—Cable "A" green wire from junction terminal (5).

ILLUS. 155

WIRING DIAGRAM

(Later Model Sidecar)

## INSTRUMENTS

### SERVICING SPEEDOMETER

To lubricate the speedometer drive core or replace a damaged or broken core, proceed as follows:

#### GLIDE

Remove instrument panel cover. Remove two screws that secure speedometer head to instrument panel base. Lift speedometer head as far as casing will permit, and with pliers, loosen case coupling nut from speedometer head. Withdraw core from casing. To free a broken core from casing, disconnect lower case coupling nut from speedometer drive unit located at transmission on Glide

To install a speedometer head and drive case, reverse the order of disassembly.

Install core in upper end of casing, applying a light coat of graphite grease to the core as it is inserted into position. Engage squared lower end of core in speedometer drive shaft. Connect case coupling upper end to the speedometer head, engaging squared end of core in speedometer shaft. Be sure to tighten both case coupling nuts securely.



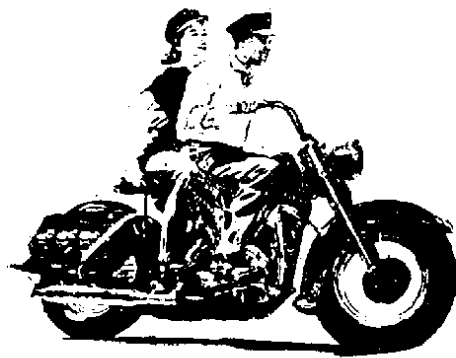

**This Service Manual is dedicated to attaining for Harley-Davidson motorcycle owners the highest degree of performance and satisfaction.**

**Except when a particular model or year model is indicated, the information in this manual applies to O.H.V. Twin Models back to 1948.**