

# SERVICE MANUAL

APPLYING TO  
THE FOLLOWING  
HARLEY-DAVIDSON  
MOTORCYCLES—  
1940 to 1947 INCLUSIVE

## O.H.V. Engine Models

61 Cu. In. (1000 c.c.)

74 Cu. In. (1200 c.c.)

## Side Valve Engine Models

74 Cu. In. (1200 c.c.)

80 Cu. In. (1300 c.c.)



Printed in the United States of America

## SECTIONAL INDEX

TROUBLE CHART  
Pages 6 to 8

INITIAL SERVICING OF NEW  
MOTORCYCLE  
Pages 10 and 11

ENGINE LUBRICATION  
Pages 30 to 36

ENGINE OVERHAUL  
Pages 37 to 91

ELECTRICAL SYSTEM  
Pages 92 to 118

SERVICING CARBURETOR  
Pages 119 to 125

TRANSMISSION AND  
CLUTCH, Pages 126 to 146

WHEELS, HUBS AND  
TIRES, Pages 147 to 153

FORK, FRAME AND HANDLE-  
BARS, Pages 153 to 158

SIDECAR  
Pages 162 and 163

DETAILED INDEX  
Pages 164 and 165

# FOREWORD

---

---

This Service Manual is dedicated to attaining for Harley-Davidson motorcycle owners the highest degree of performance and satisfaction.

Except when a particular model or year model is indicated, the information in this manual applies to both, O.H.V. and Side Valve Models, 1940 to 1947, and in a general way to Big Twin Models back to 1937.

To others than Harley-Davidson dealers and their mechanics. If you have any questions pertaining to service information in this manual, or special tools mentioned, see your Harley-Davidson dealer.

## GENERAL SPECIFICATIONS

MODEL	E and EL	F and FL	U and UL	UH and ULH
Type of Engine	61 Cu. In. O.H.V. Twin	74 Cu. In. O.H.V. Twin	74 Cu. In. Side Valve Twin	80 Cu. In. Side Valve Twin
Cylinder Bore	3 $\frac{5}{16}$ "	3 $\frac{7}{16}$ "	3 $\frac{5}{16}$ "	3 $\frac{7}{16}$ "
Stroke	3 $\frac{1}{2}$ "	3 $\frac{31}{32}$ "	4 $\frac{9}{32}$ "	4 $\frac{9}{32}$ "
Piston Displacement	60.32 Cu. In.	73.66 Cu. In.	73.79 Cu. In.	78.75 Cu. In.
Compression Ratio (Low compression engine)	E Model 6.5 to 1	F Model 6.6 to 1	U Model 5.0 to 1	UH Model 5.2 to 1
Compression Ratio (High compression engine)	EL Model 7.0 to 1	FL Model 7.0 to 1	UL Model 5.5 to 1	ULH Model 5.7 to 1
Horsepower (N.A.C.C. Rating)	8.77	9.44	8.77	9.44
Wheelbase	59 $\frac{1}{2}$ "	59 $\frac{1}{2}$ "	59 $\frac{1}{2}$ "	59 $\frac{1}{2}$ "

## ENGINE (SERIAL) NUMBER

In identifying a motorcycle as to its year and model, do not trust simply to knowledge of original differences in equipment and general appearance of one year's model as compared with another. Always identify by Engine (Serial) Number.

Example: 46 EL 2222

46  
Year

EL  
Model

2222  
Serial Number

## TIRE INFLATION PRESSURES

	REAR	REAR	SIDECAR	PACKAGE TRUCK
Solo—Rider Only 4.00" x 18" Tire 5.00" x 16" Tire	16 lbs. 14 lbs.	16 lbs. 14 lbs.		
Solo—Rider and One Passenger 4.00" x 18" Tire 5.00" x 16" Tire	26 lbs. 16 lbs.	26 lbs. 16 lbs.		
Sidecar—Rider and One Sidecar Passenger or 150 lb. Sidecar Load 4.00" x 18" Tire 5.00" x 16" Tire	24 lbs. 16 lbs.	24 lbs. 16 lbs.	14 lbs. 14 lbs.	
Package Truck—Rider and 150 lb. Truck Load 4.00" x 18" Tire 5.00" x 16" Tire	30 lbs. 20 lbs.	30 lbs. 20 lbs.		16 lbs. 14 lbs.

Tire inflation pressures are based on rider and passenger weight of approximately 150 lbs. each; Package Truck load 150 lbs.

When these loads are exceeded by 50 lbs. or more, increase tire pressure as follows: For each 50 lbs. of overload, increase pressure of rear tire 2 lbs.; front tire, 1 lb; sidecar or package truck tire, 1 lb.

## STANDARD GEAR RATIOS

MODEL	SOLO OR SIDECAR	TYPE OF TRANSMISSION	ENGINE SPROCKET	HIGH GEAR RATIO
E and EL	Solo	3 Speed	22	3.90 to 1
		4 Speed	23	3.73 to 1
	Sidecar	3 Speed—Reverse	18	4.76 to 1
		4 Speed	20	4.29 to 1
F and FL	Solo	3 Speed	23	3.73 to 1
		4 Speed	23	3.73 to 1
	Sidecar	3 Speed—Reverse	20	4.29 to 1
		4 Speed	21	4.08 to 1
U and UL	Solo	3 Speed	21	4.08 to 1
		4 Speed	22	3.90 to 1
	Sidecar	3 Speed—Reverse	18	4.76 to 1
		4 Speed	20	4.29 to 1
UH and ULH	Solo	3 Speed	22	3.90 to 1
		4 Speed	23	3.73 to 1
	Sidecar	3 Speed—Reverse	19	4.51 to 1
		4 Speed	20	4.29 to 1

## GASOLINE AND OIL CAPACITIES

MODEL	74" AND 80" SIDE VALVE	61" AND 74" O.H.V.
Left Gasoline Tank	2 U.S. Gallons	2 U.S. Gallons
Right Gasoline Tank	2 U.S. Gallons	1¼ U.S. Gallons
Reserve Gasoline Supply (included above)	Approximately 1 U.S. Gallon	Approximately 1 U.S. Gallon
Oil Tank	1 U.S. Gallon	1 U.S. Gallon
Transmission	1½ U.S. Pints	1½ U.S. Pints

### Memoranda

---



---



---



---



---



---

## INSTRUMENT PANEL SIGNAL LIGHTS

*1946 and Earlier Models:* Green light in left side of instrument panel indicates whether or not generator is charging.

Red light in right side of instrument panel indicates whether or not oil is circulating.

*1947 Models:* Red light marked "GEN" in center of instrument panel indicates whether or not generator is charging.

Red light marked "OIL" in center of instrument panel indicates whether or not oil is circulating.

*All Models:* When switch is turned "ON" preparatory to starting engine, both lights should go "ON." (Exception: When switch is turned "ON" immediately after engine has been primed by cranking, oil pressure signal may not light, but will light after a few seconds. This is due to oil pressure built up by cranking and is most likely to be noticed in cold weather.)

With engine started and running at a fair idling speed, both lights should go "OFF." At slow idling speed or under about 20 miles per hour road speed in high gear, generator signal will normally flash "ON" and "OFF" because at that speed generator output is very low and unsteady.

Should generator signal fail to go "OFF" at speeds above approximately 20 miles per hour, generator is either not charging at all or its output is not up to normal and it should be inspected at once.

Should oil circulation signal fail to go "OFF" at speeds above idling, it is most likely due to: empty oil tank; oil supply badly diluted, or using very light grade of oil and pump not building up normal pressure; if freezing weather, oil feed pipe may be clogged with ice or sludge. However, it may be: grounded oil signal switch wire, faulty signal switch; or oil pump in bad order. Give due attention to oil supply and, if signal still does not operate normally, check to see if oil returns to tank. To do this, remove oil tank cap and, with engine running, look for pulsating return of oil. A small flashlight is an aid in making this check. If oil is returning, motorcycle can be driven slowly, but no further than absolutely necessary before checking and servicing oiling system. If oil is not returning, do not drive further before having the fault corrected; as engine is likely to be damaged.

## STARTING ENGINE

When starting engine, gear shifter handle must be in neutral and clutch fully engaged. Spark should be fully advanced or nearly so.

Note: Choke lever positions are as follows:

*O.H.V. Engine:* Choke lever all the way down, choke is "closed"; choke lever all the way up, choke is "open."

*Side Valve Engine:* Choke lever all the way up, choke is "closed"; choke lever all the way down, choke is "open."

*All Models: Starting Cold Engine:* Set choke lever in fully-closed position, open throttle wide, and with ignition switch "OFF," prime cylinders by operating starter crank once or twice.

Then, with choke lever set  $\frac{1}{4}$  or  $\frac{1}{2}$  closed in mild weather,  $\frac{3}{4}$  or fully closed in extremely cold weather, and throttle slightly open, turn ignition switch "ON" and start engine with vigorous strokes of starter.

**CAUTION:** It is only in extremely cold weather that engine may start best with choke fully closed, and even then, it will have to be moved from this position immediately after engine starts. Under no conditions will engine continue to run with full choke.

As soon as engine starts, set throttle for moderate idling speed while warming up or until ready to set motorcycle in motion.

As engine warms up and misfires due to an over-rich mixture, gradually move choke lever toward open position. After engine has thoroughly warmed up, move choke lever to fully open position.

*Starting Warm Engine:* This applies to engine half way between hot and cold. Move choke lever to  $\frac{1}{4}$  closed position and with throttle closed, operate starter once or twice. Then, with throttle  $\frac{1}{4}$  to  $\frac{1}{2}$  open, turn ignition switch "ON" and operate starter. Soon after engine starts, choke lever should be moved back to fully open position. Remember: This procedure calls for having throttle part way open during starting strokes after switch has been turned "ON."

*Starting Hot Engine:* If engine has been shut off for only a brief period and is at about normal running temperature, it is not necessary to use choke lever. Simply close throttle, turn ignition switch "ON" and operate starter. With some engines, depending on carburetor adjustment, hot starting is more dependable if starter is given one stroke before turning ignition switch "ON."

When a hot engine does not start readily, that is, with two or three starter strokes, it is usually due to an over-rich (flooded) condition, and the proper procedure then is to open throttle wide so more air can enter, closing it quickly as engine starts.

## TO STOP ENGINE

Stop engine by turning ignition switch "OFF." If engine should be stalled or stopped in any other way than with switch, turn switch "OFF" at once to prevent battery from being discharged through circuit breaker points.

Don't idle engine unnecessarily with motorcycle standing.

## RUNNING IN NEW ENGINE

Don't run new motorcycle faster than 35 miles per hour the first 250 miles; 40 miles per hour the second 250 miles; 45 miles per hour (sidecar) or 50 miles per hour (solo) the next 500 miles. Avoid running at or near top speed for long distances below 2000 miles.

After a new motorcycle has been run 500 to 1000 miles it needs to be thoroughly checked over and any loose screws and nuts tightened. Particular attention must be given to those that secure engine and transmission; also to wheel mounting socket screws. See that this attention is given.

Both chains should be checked for ample lubrication.

## HIGH SPEED TIPS

Develop the habit of frequently snapping throttle shut for an instant when running at high speed. This draws additional lubrication to pistons and cylinders and helps cooling.

In cold weather run engine slowly until it is thoroughly warmed up, to avoid possible damage to piston rings, pistons and other parts before oil is warm enough to circulate freely.

A motorcycle run long distances at high speed must be given closer than ordinary attention to avoid overheating and possible consequent damage. Engine must be kept well tuned, especially as concerns valve seating, good compression, spark plugs and ignition timing. Carburetor should be adjusted moderately rich, rather than too lean. This applies particularly when motorcycle is equipped with handlebar windshield and legshields.

## TROUBLE CHART

### Engine

Note: Too frequently, spark plugs and or ignition coil are thought to be defective when engine starts hard, runs irregularly, or fails to start.

Sometimes when a spark plug fails to function normally, it is the result of an accumulation of dirt on plug core which becomes a conductor when damp or wet, allowing spark to jump from cable terminal to plug base, instead of across electrodes in combustion chamber. Under such a condition, wiping plug core clean with a dry rag will allow plug to function normally.

An ignition coil suspected of being defective may only need new spark plug cables installed. Cable insulation eventually deteriorates and sometimes cracks at the point where cable enters coil case. Spark may then jump from cable to cable packing nut (on coil case) instead of across electrodes in combustion chamber, especially if cables are damp or wet.

#### *If engine starts hard:*

1. Spark plugs in bad condition, or partially fouled.
2. Spark plug cables in bad condition and "leaking."
3. Circuit breaker points out of adjustment or in need of cleaning.
4. Battery nearly discharged.
5. Loose wire connection at one of battery terminals or at coil or circuit breaker.
6. Carburetor not adjusted correctly.

7. Defective ignition coil.
8. Defective condenser.

#### *If engine starts but runs irregularly or misses:*

1. Spark plugs in bad condition, or partially fouled.
2. Spark plug cables in bad condition and "leaking."
3. Spark plug gap too close.
4. Circuit breaker points out of adjustment or in need of cleaning.
5. Condenser connections loose.
6. Defective ignition coil.
7. Defective condenser.
8. Battery nearly discharged.
9. Loose wire connection at one of battery terminals or at coil or circuit breaker.
10. Intermittent short circuit due to damaged wiring insulation.
11. Water or dirt in fuel system and carburetor.
12. Gasoline tank cap vent plugged and tank air bound.
13. Carburetor not adjusted correctly.
14. Weak or broken valve springs.

#### *If engine fails to start, it may be due to one or more of the following conditions:*

1. Gasoline tank empty.
2. Gasoline valve shut off.
3. Gasoline line clogged.
4. Discharged battery or loose or broken battery terminal connection. Check by turning light switch "ON."
5. Fouled spark plugs.
6. Spark plug cables in bad condition and "leaking."
7. Badly oxidized ignition circuit breaker points.
8. Circuit breaker points badly out of adjustment.
9. Loose wire connection at one of battery terminals or at coil or circuit breaker.
10. Defective ignition coil.
11. Defective condenser.
12. Clutch slipping and starter not turning engine over.
13. Sticking valves, or tappets too tight.
14. Engine flooded with gasoline as a result of over-choking.

#### *If a spark plug fouls repeatedly:*

1. Too cold a plug for the kind of service or for type of engine.
2. Piston rings badly worn or in bad condition otherwise.
3. Oil pump improperly adjusted—oil pressure too high.
4. O.H.V. Engine—intake valve spring cover oil return line clogged with carbon or sludge. One or more push rod cover cork washers in bad condition or push rod covers not seating properly against cork washers.

#### *If engine preignites:*

1. Excessive carbon deposit on piston head or in combustion chamber.

2. Too hot a spark plug for the kind of service or for type of engine.
3. Defective spark plugs.

***If engine overheats:***

1. Insufficient oil supply, or oil not circulating.
2. Leaking valves.
3. Heavy carbon deposit.
4. Carburetor high speed adjustment too lean.
5. Ignition timing too late.

***If engine detonates:***

1. Unsuitable fuel (octane rating too low).
2. Heavy deposit of carbon on piston head and in combustion chamber (decreases combustion space, thereby increasing compression ratio. The higher the compression ratio, the higher the octane rating of fuel required).

***If oil does not return to oil tank:***

1. Oil tank empty.
2. Scavenger pump gear key sheared.
3. Oil feed pump not functioning.

***If engine uses too much oil:***

1. Breather valve incorrectly timed.
2. Oil pressure too high—readjust oil pump.
3. Piston rings badly worn or in bad condition otherwise.
4. O.H.V. Engine—intake valve spring cover oil return line clogged with carbon or sludge. One or more push rod cover cork washers in bad condition or a push rod cover not seating properly against its washer.
5. Chain oiler adjusting screw adjusted for an excessive amount of oil.

***Excessive vibration:***

1. Cylinder bracket loose or broken.
2. Engine mounting bolts loose.
3. Broken frame.
4. Front chain badly worn, or links tight as a result of insufficient lubrication.
5. Transmission and/or transmission sub-mounting plate loose in chassis.

## **Generator**

***If generator does not charge:***

1. Brushes badly worn.
2. Brushes sticking in holders.
3. Relay, or current and voltage regulator, not grounded.
4. Defective relay or current and voltage regulator.
5. Commutator dirty or oily.
6. Positive brush holder grounded.
7. Generator "relay" terminal grounded.
8. Loose or broken wire in generator-battery circuit.
9. Broken field coil wire or loose terminal (both coils).

10. Commutator shorted.
11. Defective armature.

***If generator charging rate is below normal:***

1. Regulating brush not properly adjusted.
2. Current and voltage regulator not properly adjusted.
3. Broken field coil wire or loose terminal (one coil).
4. Commutator worn and not turning true with shaft—throws brushes at high speed.
5. Commutator dirty or oily.
6. Brushes gummy and sluggish in holders.
7. Defective armature.

## **Carburetor**

***If carburetor floods:***

1. Float set too high.
2. Float valve sticking.
3. Float valve and/or valve seat worn or damaged.
4. Dirt or other foreign matter between float valve and its seat.
5. Carburetor float not located correctly in bowl—may be binding.

## **Transmission**

***If transmission shifts hard:***

1. Bent shifter rod.
2. Clutch dragging slightly.
3. Transmission oil too heavy (winter operation).
4. Shifter forks (inside transmission) sprung as a result of using too much force when shifting.
5. Corners worn off shifter clutch dogs (inside transmission)—makes engagement difficult.

***If transmission jumps out of gear:***

1. Shifter rod improperly adjusted.
2. Shifter forks (inside transmission) improperly adjusted.
3. Shifter engaging parts (inside transmission) badly worn and rounded.

***If clutch slips:***

1. Clutch controls improperly adjusted.
2. Insufficient clutch spring tension.
3. Worn and/or oil soaked friction discs.

***If clutch drags or does not release:***

1. Clutch controls improperly adjusted.
2. Clutch spring tension too tight.
3. Friction discs gummy.
4. Clutch key ring badly worn.

***If clutch chatters:***

1. Clutch disc rivets loose.
2. Clutch sprung disc too flat.

(Continued on next page)



## Brakes

### *If brake does not hold normally:*

1. Brake improperly adjusted.
2. Brake controls binding as result of improper lubrication, or being damaged.
3. Brake linings impregnated with grease as result of overgreasing wheel hub and/or brake operating shaft.
4. Brake linings badly worn.
5. Brake drum badly worn and/or scored.

---

## GENERAL LUBRICATION

Refer to Lubrication Chart

### Special Instructions

Note: If predominating service conditions are either wet or muddy, or very dusty, the 750 and 1500 mile greasing intervals should be reduced to 500 and 1000 miles respectively.

- 15—Every 5000 miles, or at least once a year, pack generator commutator end bearing with high melting point grease (Harley-Davidson grade "A" grease). See "Lubricating Commutator End Armature Bearing," Page 105.
- 16—Lubricate front wheel brake handlever and control cable every 750 miles or whenever operation of brake indicates lubrication is necessary.
- 17-21—Twice a year, or whenever operation of grips indicates lubrication is necessary, remove grips and clean parts, then apply grease (Harley-Davidson "Chassis" grease) and reassemble. See "Servicing Handlebar Controls," Page 25.
- 18—If engine is equipped with air cleaner, wash with gasoline or solvent, and reoil, at least each time engine oil tank is drained and refilled. Service more frequently under dusty conditions; daily under extremely dusty conditions. See "Servicing Air Cleaner," Page 10.
- 19—Drain engine oil tank and refill with fresh oil at least every 2000 miles. In dusty service, and in winter weather, change oil oftener. See "Engine Lubrication," Page 33, and very carefully read complete information given.
- 20—Pack steering head bearings with high melting point grease (Harley-Davidson grade "A" grease) every 50,000 miles, or whenever there is occasion to remove rigid fork for repair or replacement of parts. See "Removing and Installing Forks," Page 153.
- 22—Remove filler plug and check transmission oil level every two weeks or every 1000 miles, whichever comes first, and add oil if necessary. Fill to level of filler opening. See "Transmission Lubrication," Page 144.

**CONTROLS:** To keep controls working freely, all control joints which are not provided with grease fitting should be oiled regularly with oil can, particularly after washing motorcycle or operating in wet weather. Spark, throttle and front brake control wires should also be oiled at ends of control wire housings near circuit breaker, carburetor and front brake respectively.

**DRIVE CHAINS:** (See "Lubricating Drive Chains," Page 12).

**CIRCUIT BREAKER CAM:** Apply a very light coating of grease to cam every 1000 miles.

**SPEEDOMETER:** Every 15,000 miles lubricate speedometer core. This necessitates removing speedometer head, disconnecting core housing from transmission and removing core. Place about a tablespoonful of special speedometer core lubricant in one hand and feed core through the grease and into the housing. Under no circumstances should housing be filled with grease. See "Removing and Installing Speedometer Head and Drive Core," Page 161.

**SIDECAR:** Four grease fittings are provided. One at each end of frame rear cross tube (brake cross shaft bearings); one on brake side cover (brake operating shaft); one on wheel hub. Lubricate hub at 1500 mile intervals; other bearings at 750 mile intervals. Oil sidecar brake linkage regularly with oil can.

---

Be careful about over-greasing wheel hubs, brake operating shafts and front wheel brake cover bushing, as excess grease working out of these bearings or bushings not only develops a messy condition, but is also likely to get onto brake linings, which will greatly reduce efficiency of brakes.

---



# LUBRICATION CHART

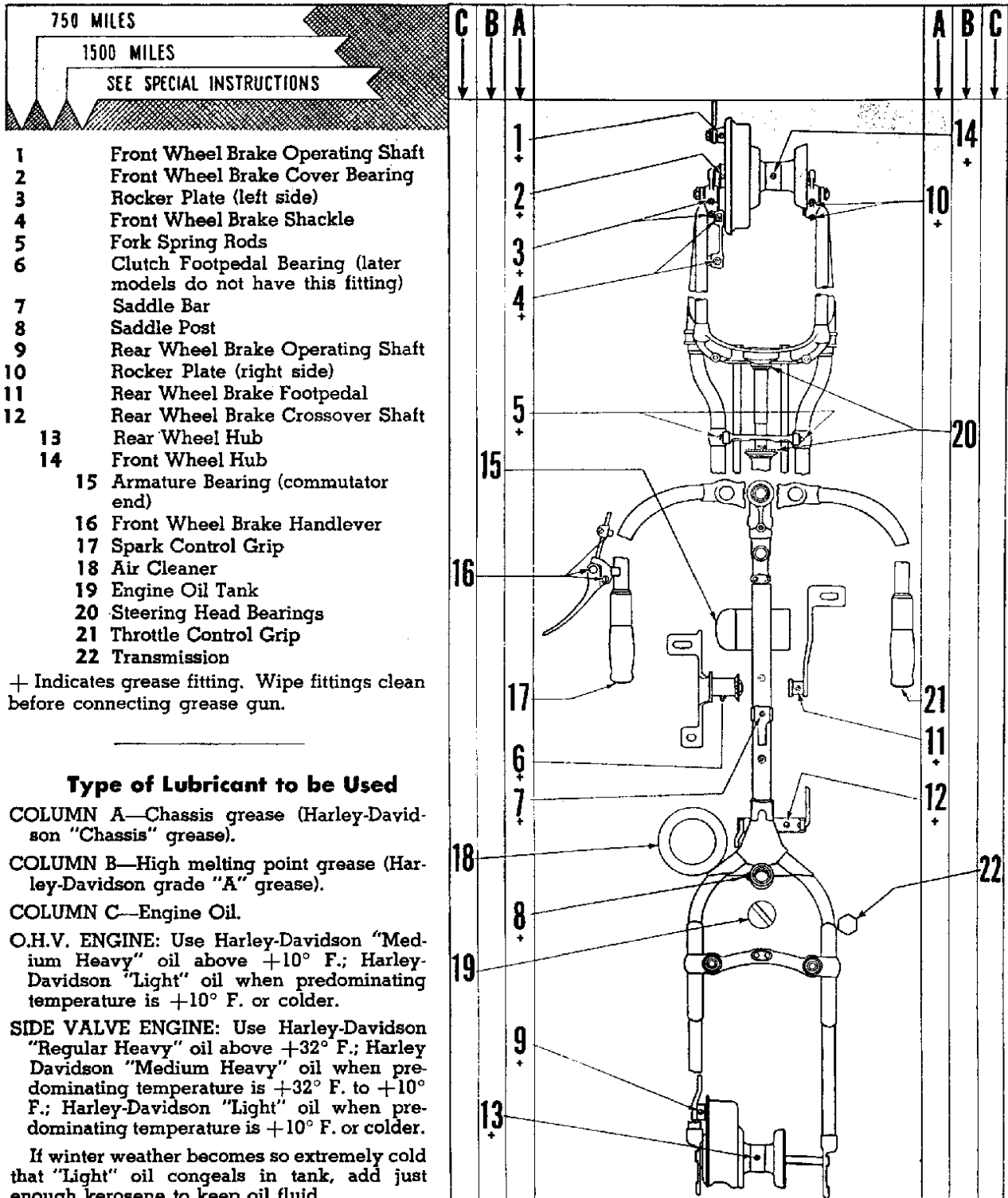

ILLUS. 1

## SERVICING AIR CLEANER

### Mesh Pack Type Cleaner

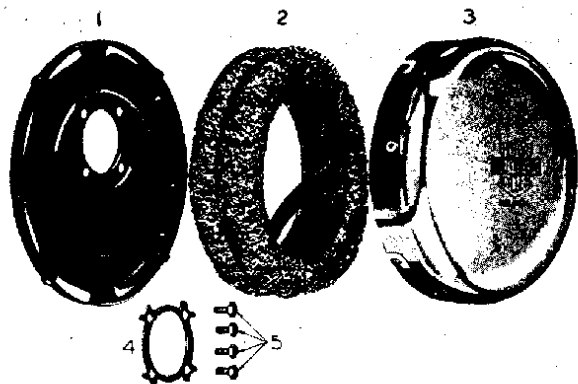

ILLUS. 2

AIR CLEANER DISASSEMBLED (MESH PACK TYPE)

1. Air cleaner back plate.
2. Air cleaner mesh with support.
3. Air cleaner cover.
4. Air cleaner mounting screw lock.
5. Air cleaner mounting screws.

In normal service on hard surface roads, it is important that the air cleaner metal mesh be removed, washed thoroughly in gasoline or kerosene (or solvent), and then saturated with same grade of new oil as used in engine at least once every 1000 miles. In dusty service this attention should be given more frequently and in extremely dusty service every 100 miles or at least once a day.

To remove air cleaner cover, press inward and turn counter-clockwise. After mesh pack has been cleaned in gasoline or kerosene (or solvent), dip it in engine oil and allow excess oil to drain off, then reassemble and attach mesh pack assembly and cover by reversing removal operations. Cover must be attached with drain hole at bottom.

### Oil Bath Type Cleaner

A few motorcycles are in service equipped with an oil bath type air cleaner.

Clean and refill air cleaner oil cup at least each time engine oil tank is drained and refilled. Service frequently under dusty conditions.

Remove oil cup and baffle, thoroughly clean them and refill to indicated level with same grade of new oil as used in engine. Do not fill oil cup above indicated oil level as a higher level will restrict passage of air through cleaner and upset carburetion to the extent that engine may not start at all, or at best run very irregularly. The effect is the same as running with choke partially or fully closed.

When reassembling, observe that oil cup gasket is in place and make sure oil cup and baffle are properly seated against gasket and secured to cleaner housing. Careless assembly is likely to result in an oil leak between cup and cleaner housing and possibly a lost cup.

Occasionally, at time of servicing oil cup, complete cleaner should be removed from motorcycle and immersed for a time in a bucket of gasoline or kerosene (or solvent). Cleaner element, which cannot be removed from housing, must be thoroughly flushed to wash out accumulated dirt. After flushing, dry thoroughly (use an air hose if available) and apply a few squirts of engine oil to inside of cleaner element, using oil can.

Note: Observe instructions on air cleaner body.

## INITIAL SERVICING OF NEW MOTORCYCLE

### At First 250 Miles

1. At the first 250 miles, check front chain to make sure it is receiving required amount of oil for ample lubrication. If necessary, readjust chain oiler. See "Lubricating Drive Chains," Page 12. Note: If motorcycle is equipped with rear chain oiler, instructions that apply to checking front chain lubrication, also apply to rear chain.
2. Check adjustment of chains. Readjust if needed.

### At First 750 Miles

1. Drain oil tank and refill with fresh oil. Thereafter, in average service change oil at intervals not exceeding 2000 miles. In extremely dusty serv-
2. ice, or when service is exceptionally hard, also in winter weather, oil must be changed at much shorter than normal intervals. See "Engine Lubrication," Page 33.
3. Check level of oil in transmission and add oil if needed. Use same grade of oil used in engine. See "Transmission Lubrication," Page 144.
4. Lubricate all points indicated for 750 mile attention on Lubrication Chart.
5. Oil all control joints, namely, clutch, gear shifter, brakes, front brake control wire, and spark and throttle control wires at ends of their respective housings.
5. If motorcycle is equipped with air cleaner, inspect and service if needed. See "Servicing Air Cleaner."

6. Check adjustment of chains and readjust if needed. Again, check lubrication of front chain and readjust chain oiler if found necessary. Clean and lubricate rear chain.
7. Check adjustment of brakes. Readjust controls if needed.
8. Check wheel mounting socket screws and tighten if needed. These screws must be kept very tight.
9. Check axle nuts and fork rocker plate stud nuts for looseness.
10. Check level of battery solution and add distilled water if needed. See that terminals are clean and connections tight.
11. Inspect all wiring connections and tighten any found loose. Check switches, lights, etc.
12. Check carburetor-manifold cap screws and manifold nuts.
13. Road test motorcycle to check carburetor adjustment and all-around performance.

### **At First 1500 Miles**

1. Check condition of oil in tank to determine if oil change is needed.
2. Check level of oil in transmission and add oil if needed. Use same grade of oil used in engine. See "Transmission Lubrication," Page 144.
3. Lubricate all points indicated for 750 mile attention on Lubrication Chart.
4. Lubricate wheel hubs at 1500 mile intervals as indicated on Lubrication Chart.
5. Oil all control joints, namely clutch, gear shifter, brakes, front brake control wire, and spark and throttle control wires at ends of their respective housings.
6. Check adjustment of chains. Adjust if needed. Again, check lubrication of front chain. Clean and lubricate rear chain and check for broken rollers, loose pins or cracked side plates.
7. Check adjustment of gear shifting control. Adjust if needed.
8. Check adjustment of clutch and clutch control. Adjust if needed.
9. Check adjustments of brakes and brake controls. Adjust if needed.
10. Check all nuts, bolts and screws and tighten any found loose. Particular attention should be given to engine mounting bolts, cylinder head bracket bolts or nuts, transmission mounting stud nuts, and wheel mounting socket screws.
11. Check front and rear wheel for loose or broken spokes and rim damage.
12. Check level of battery solution and add distilled water if needed.
13. Engine should be given a complete tune-up including: Checking circuit breaker points, ignition timing, valve tappets, spark plugs, draining and flushing carburetor bowl, cleaning and flushing gasoline strainer, carburetor adjustment, and cleaning muffler outlet. Service air cleaner if motorcycle is so equipped.
14. Road test motorcycle to check carburetor adjustment and all-around performance.

preceding three service jobs conclude what is considered initial servicing. Further servicing should be given according to schedule of "Regular Interval Inspection and Maintenance," which follows below.

## **REGULAR INTERVAL INSPECTION AND MAINTENANCE**

After schedule of initial servicing of new motorcycle has been completed, this maintenance schedule is then to be followed at regular intervals not exceeding 1500 miles.

1. Check condition of oil in tank to determine if oil change is needed.
2. Lubricate all points indicated for 750 mile attention on Lubrication Chart.
3. Lubricate wheel hubs at 1500 mile intervals as indicated on Lubrication Chart.
4. Oil all control joints, namely, clutch, gear shifter, brakes, front brake control wire, and spark and throttle control wires at ends of their respective housings.
5. If motorcycle is equipped with air cleaner, inspect and service if needed. See "Servicing Air Cleaner," Page 10.
6. Remove rear chain, check for broken rollers, loose pins or cracked side plates, and then clean and lubricate as per instructions under "Lubricating Drive Chains," Page 12. Check front chain for ample lubrication. Adjust chains.
7. Flush chain oiler passage as explained under "Lubricating Drive Chains," Page 12.
8. Check clutch and clutch control adjustments. Readjust if needed.
9. Check brakes. Readjust controls if needed.
10. Check all nuts, bolts, and screws and tighten any found loose.
11. Check wheel mounting socket screws and tighten if needed. These screws must be kept very tight.
12. Check axle nuts and fork rocker plate stud nuts for looseness.
13. Check front and rear wheel for loose or broken spokes and rim damage.
14. Clean and flush gasoline strainer.
15. Remove carburetor bowl drain plug and flush bowl.
16. Check level of battery solution and add distilled water if needed.
17. Inspect all wiring connections. Check switches and lights.
18. Completely tune up engine, including: Checking circuit breaker points, ignition timing, valve tappets, spark plugs, carburetor adjustment, and cleaning muffler outlet.
19. Note that generator and oil pressure signal lights, in switch panel, go out when engine is running above idling speed.

20. Road test motorcycle to check carburetor adjustment and all-around performance.

Once every 5000 miles, or at least once a year (if total yearly mileage is less than 5000 miles), lubricate commutator end bearing of generator with high melting point grease (Harley-Davidson grade "A" grease).

## CARE AND LUBRICATION OF DRIVE CHAINS

### Adjusting Drive Chains

Inspect the adjustment of chains at least every week and adjust them if necessary. Adjustment of front chain can be checked through inspection hole provided in chain guard. Chains must not be allowed to run loose enough to strike guards or other chassis parts, because when that loose, they cause motorcycle to jerk when running at low speed, and there is excessive wear of chains and sprockets. The rear chain requires more frequent adjustment than front chain. As chains stretch and wear in service, they will run tighter at one point on the sprockets than at another. Always check adjustment at the tightest point and adjust chains at this point so that they have about 1/2-inch free movement up and down, midway between sprockets. Do not adjust tighter because running chains too tight is even more harmful than running them too loose.

Inspect chains occasionally for links in bad condition. If any are found, make repairs or renew the chain. The rear chain can be taken apart and removed after locating and taking out the spring locked connecting link. The front chain is not, however, originally provided with such a connecting link and whether or not one has at sometime been installed in making repairs, it will be necessary to remove the engine sprocket before chain can be taken off.

### To Adjust Front Chain

Loosen the four stud nuts and one cap screw underneath transmission. This permits moving transmission backward or forward by means of adjusting screw at rear of transmission on right side. Turn adjusting screw to *right to tighten chain—left to loosen chain*. When chain is correctly adjusted, securely tighten stud nuts and cap screw and recheck chain, as tightening stud nuts and cap screw sometimes changes chain adjustment. Also check transmission mounting plate bolts occasionally and keep them tight.

Adjusting front chain changes the adjustment of rear chain, therefore, rear chain must also be adjusted.

Moving transmission to adjust front chain, also affects adjustment of gear shifter and clutch controls. Therefore, each time front chain is adjusted, these controls will need to be adjusted or at least their adjustment will have to be checked. See "Checking and Adjusting Clutch Control," Page 15, and "Checking and Adjusting External Shifter Control," Page 14.

### To Adjust Rear Chain

Remove rear axle nut and lock washer and loosen brake sleeve nut. Also loosen rear wheel adjusting screw lock nuts (one on each side of frame).

Turn adjusting screws to move rear wheel as necessary to correctly adjust chain. Assuming that wheel was correctly aligned the last time chain was adjusted, turning each screw an equal number of turns will maintain alignment.

When correct adjustment of chain is attained, securely tighten brake sleeve nut, rear axle nut and adjusting screw lock nuts. Then recheck chain adjustment, as tightening brake sleeve nut and axle nut sometimes changes chain adjustment.

Check alignment of wheel in chassis. This can be done by measuring the distance from inner side of chain to tire rim. For 5.00" x 16" tire rim, the distance should be approximately 1-3/16", and for 4.00" x 18" tire rim, the distance should be approximately 1 1/8". Distance between chain and rim should be checked at four equidistant points around rim, and if it happens to be out of true sideways to any appreciable degree, this will have to be taken into consideration. If measurement indicates wheel is out of alignment in chassis, it must be corrected, and of course, chain adjustment will have to be rechecked.

After adjusting rear chain, rear brake may be found too tight. Check and adjust if necessary. See "Adjusting Rear Wheel Brake," Page 20.

## LUBRICATING DRIVE CHAINS

### Lubricating Front Chain

Front chain is automatically lubricated by engine oil pump. Chain oiling is adjustable and occasional readjustment may be needed to meet lubrication requirements of varied operating conditions.

As nearly everyone knows through experience, the good performance and life of a front chain depends entirely upon its ample lubrication. The quantity of oil required for ample lubrication is very slight. However, oiling must be constant. If oiling fails for a period of only a few hours or a few hundred miles, especially when operating at high speed, chain is likely to be ruined. Initial oiling adjustment is set at the factory as closely as possible to normal service requirements; however, the quantity of oil involved is so small, initial adjustment cannot always be trusted as final. Standard factory setting of chain oiler adjusting screw (Item (17), Illus. 56, or Item (3), Illus. 3) is as follows: *O.H.V. Models*—1 full turn open; *Side Valve Models*—1 1/2 turns open. A 1/16" washer and required number of .002" washers are placed under screw head so that when screw head bottoms against washers point of screw is the specified number of turns off its seat.

At the intervals specified under "Initial Servicing of New Motorcycle," Page 10 and "Regular Interval Inspection and Maintenance," Page 11, remove inspection hole cover from chain guard and make a very close inspection of chain. If chain appearance



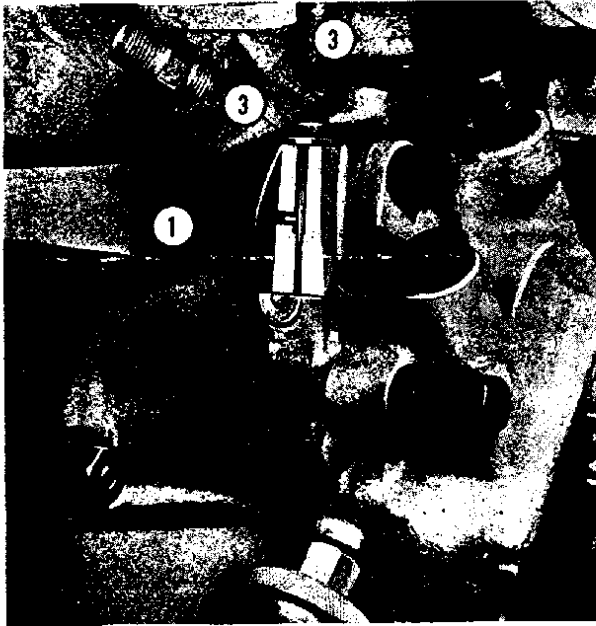

ILLUS. 3

CHAIN OILER ADJUSTING SCREW AND OIL PASSAGE  
(SIDE VALVE ENGINE)

1. Chain oil passage in gear case cover.
2. Chain oiler adjusting washers.
3. Chain oiler adjusting screw.

raises the least doubt as to its getting ample lubrication, add one or two more .002" washers under head of chain oiler adjusting screw. A well lubricated chain not only has an oily surface, but is also clean and free of discoloration. If chain has a brownish hue, and rusty appearance at side and center plates, it is under-lubricated even though the surface may be oily.

Since the quantity of oil involved is very small, the opening through which oil bleeds to chain is regulated by adjusting screw to a very small orifice. Sediment and gummy matter accumulated in oil supply deposits in and around this orifice and gradually decreases the oil supplied to chain. In other words, a chain that has been lubricating perfectly the first 2000 miles may run short of oil the second 2000 miles. Therefore, even though inspection indicates chain is amply lubricated, it is advisable at intervals of approximately 2000 miles, to loosen the chain oiler adjusting screw, and back it up about two turns. Operate this way a few miles and then turn screw back down moderately tight against its adjusting washers. This procedure flushes away accumulated sediment and restores oil orifice to its original size.

The same result can be accomplished if compressed air is available, by completely removing screw and washers, flushing opening with gasoline and blowing out. When this procedure is followed, care must be taken not to lose any of the thin washers under screw head, otherwise when screw is installed, it will not have the same adjustment as it did before being removed.

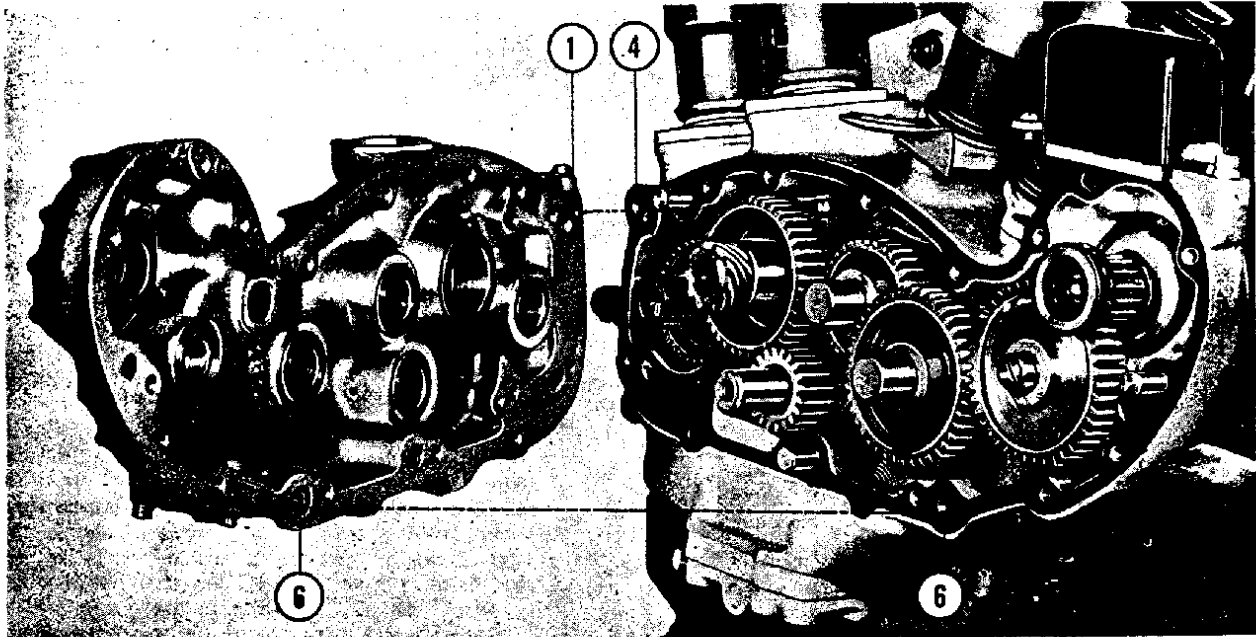

ILLUS. 4

GEAR CASE COVER REMOVED (SIDE VALVE ENGINE)

1. Chain oil passage in gear case cover.
4. Chain oil passage in crankcase.
5. Flutter valve installed in cover—assists in retrieving oil from outside breather oil trap in cover.
6. Oil passage in right crankcase through which oil in outside breather oil trap is retrieved by crankcase vacuum.

Following the above recommendations will go a long way toward eliminating chain failure.

If it is definitely determined that chain is getting an excessive amount of oil, remove one or more thin washers from under head of chain oiler adjusting screw. It is advisable to remove only one washer at a time and inspect chain again after motorcycle has been run approximately another hundred miles to determine whether or not further adjustment is needed.

### Lubricating Rear Chain

#### *Applying to rear chain not lubricated with rear chain oiler:*

Under dry, hard surface road operation, apply engine oil at 750-mile intervals. Under dusty, wet or muddy conditions, oil chain daily with a very light oil.

Occasionally chain should have additional lubrication as follows:

Remove chain from motorcycle. Soak and wash thoroughly in a pan of kerosene. After removing chain from kerosene, hang it up for a time to allow kerosene to drain off.

Immerse for a short time in a pan of grease heated to consistence of light engine oil. If grease and facilities for heating are not at hand, substitute light engine oil. While immersed, move chain around to be sure that hot grease or oil works through all inside parts.

After removing from hot grease or oil, allow chain to drain and wipe all surplus grease or oil from surface of chain.

Install chain on motorcycle. Inspect connecting link and spring clip closely for bad condition. Replace if at all questionable. Be sure spring clip is properly and securely locked on pin ends.

#### *Applying to rear chain lubricated with rear chain oiler:*

A few motorcycles are equipped with rear chain oiler that automatically lubricates chain. Instructions applying to front chain lubrication, also apply to rear chain except that standard factory setting of rear chain oiler adjusting screw is  $\frac{1}{2}$  turn open.

Occasionally chain should have additional lubrication as explained above for chain not automatically lubricated.

Note: Parts for installing rear chain oiler, or for replacement, are no longer available.

## REPAIRING DRIVE CHAINS

When necessary to repair a chain, remove damaged link or links by pushing out pins with chain repair tool. Then install necessary repair links, noting that spring clips are properly and securely locked on pin ends.

Front chain is a double row or duplex chain; rear chain is a single row chain. The chain tool furnished in the tool kit is designed to accommodate both.

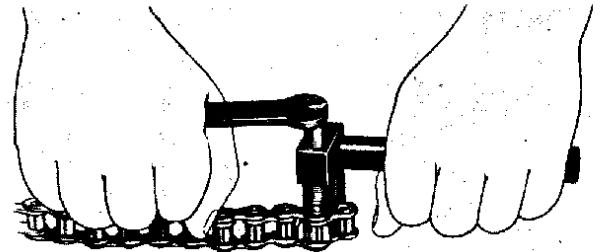

ILLUS. 5  
USE OF CHAIN REPAIR TOOL

## CLUTCH AND GEAR SHIFTER

Need for attention to clutch and control is indicated by clutch slipping under load or dragging in released position. In either case, the first thing to be checked is adjustment of control; this is the attention usually needed.

The first warning or indication of shifter control being out of correct adjustment is transmission "jumping" out of engagement when accelerating under heavy pull. This warning must not be disregarded.

### Checking and Adjusting External Gear Shifter Control

1. See that control joints from transmission gear shifter lever to gear shifter handle are well oiled and free-working.
2. Check handle center pivot bolt nut for tightness.
3. Observe whether there is binding or interference with shifter rod at any point in the shifting range; this is sometimes found as a result of bent rod.

4. Check to determine whether or not shifter rod is correctly adjusted so that when handle is moved to any gear position in shifter guide, transmission lever moves to just the right position to fully engage shifter clutch and shifter cam spring plunger (inside transmission).
5. Adjust as follows: Locate handle in shifter guide "neutral" position, disconnect shifter rod from handle and, with slight backward and forward movement, carefully "feel" transmission lever into exact position where shifter cam spring plunger (inside transmission) seats fully in retaining notch. Next, see that handle is in exact "neutral" position in the guide and adjust length of shifter rod so shifter rod end hole lines up with hole in handle. Insert bolt and tighten nut. It is advisable to repeat this check in "low" and "second" gears to be sure of having best all-around adjustment.

After each adjustment of front chain, also whenever any irregularity is noticed with shifting and positive engagement in different gear positions, adjustment of this rod must be checked.

**CAUTION:** Shifter control must be kept in correct adjustment; otherwise driving dogs on shifter clutches will not fully engage in the different positions and are likely to become damaged from jumping out of engagement under driving load.

When shifter clutches become worn or damaged to the extent of jumping out of engagement under driving load, even though shifter control is correctly adjusted, transmission must be serviced as explained under "Overhauling Transmission and Clutch," Page 126.

### Checking and Adjusting Clutch Control

1940 and Earlier Models

(To Identify Items, Refer to Illus. 6)

With footpedal (16) in full disengaged position—heel down, clutch lever (1) should stand about square across top of transmission, with just a little clearance from raised portion of transmission case cover. Adjust when found needed by lengthening or shortening foot-pedal rod (21). Following this adjustment, set foot-pedal (16) in full engaged position—*toe down*, loosen lock nut (3), and adjust screw (2) so that end of lever (1) has about  $\frac{1}{8}$  inch free movement, back and forward. Turn screw to right for less free movement; left for more.

**CAUTION:** If end of lever (1) has no free movement, clutch will not hold properly. If too much free movement is allowed, clutch will drag when in disengaged position, and consequently, transmission will shift hard, clash and eventually become damaged.

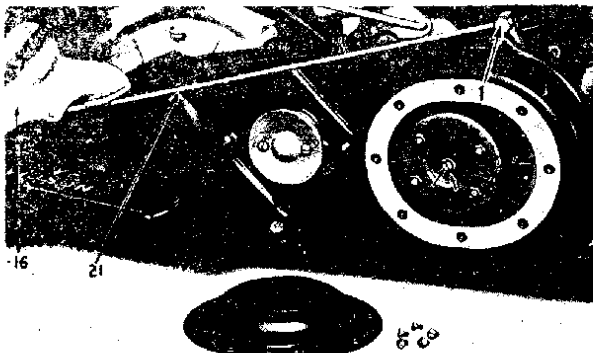

ILLUS. 6

CLUTCH CONTROL (1940 AND EARLIER MODELS)

1. Clutch lever.
2. Push rod adjusting screw.
3. Push rod adjusting screw lock nut.
16. Footpedal.
21. Footpedal rod.

### Checking and Adjusting Clutch Control

1941 to 1947 Models

(To Identify Items, Refer to Illus. 7)

Disengaging movement is limited by clutch lever (1) striking transmission case cover. Rock footpedal (16) to full disengaged position—*heel down* and observe clearance between footpedal rod end (front)

and footpedal bearing cover. There should be clearance between them but just noticeable clearance. Adjust as necessary by shortening or lengthening rod (21). Following this adjustment, set footpedal (16) in full engaged position—*toe down*, loosen lock nut (3) and adjust screw (2) so that end of lever (1) has about  $\frac{1}{8}$  inch free movement, back and forward. Turn screw to right for less free movement; left for more.

**CAUTION—**If end of lever (1) has no free movement, clutch will not hold properly. If too much free movement is allowed, clutch will drag when in disengaged position, and consequently, transmission will shift hard, clash, and eventually become damaged.

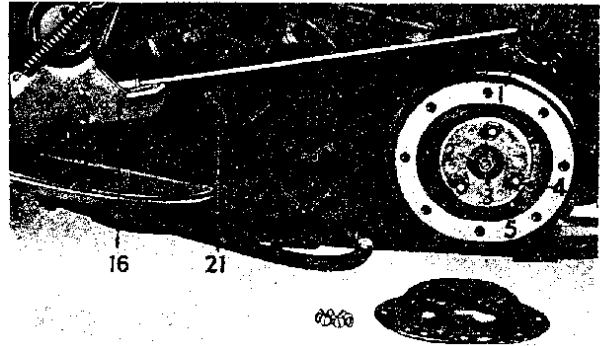

ILLUS. 7

CLUTCH CONTROL (1941 TO 1947 MODELS)

1. Clutch lever.
2. Push rod adjusting screw.
3. Push rod adjusting screw lock nut.
4. Spring tension adjusting nuts (three). } Disregard when
5. Spring tension adjusting nut locks (three). } adjusting control.
16. Footpedal.
21. Footpedal rod.

**Footnote:** During 1947 season, spring tension adjusting nut locks (5) were eliminated and adjusting nuts (4) were superseded by self locking nuts.

### Memoranda

---



---



---



---



---



---



---



---



---



---



## Adjusting Clutch Spring Tension

1940 and Earlier Models

(To Identify Items, Refer to Illus. 8)

If clutch slips, after control has been checked and correctly adjusted, increase spring tension by tightening (turn right) nut (8). To get to this nut, remove chainguard clutch cover as when adjusting control, and take off thrust plate (5). Before nut (8) can be turned, washer (7) will have to be straightened where it is set into nut slot to lock adjustment. (Note—Washer (7) is also set into slot in spring collar (11) to lock hub nut (9). Using Harley-Davidson special wrench, Part No. 12746-36, or soft punch and hammer, tighten nut (8), one turn at a time, until clutch holds. Test after each turn by cranking engine. Usually a clutch that holds without any noticeable slippage when cranking engine, also holds on the road.

Do not increase spring tension any more than actually required to make clutch hold. As new clutch is originally assembled and adjusted, the distance from face of spring collar (11) to shoulder on four thrust plate mounting studs is  $\frac{3}{8}$ ". In any case, do not tighten nut (8) to the point where spring collar (11) is more than  $\frac{11}{16}$ " away from shoulder on studs. This is about six turns of adjusting nut (8) from original adjustment. If compressed more, clutch probably cannot be fully released.

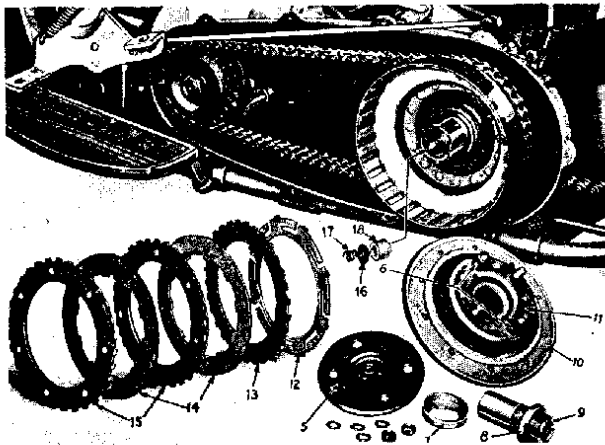

ILLUS. 8

CLUTCH DISASSEMBLED (1940 AND EARLIER MODELS)

5. Push rod thrust plate.
6. Spring compressing collars (two).  
See "Footnote."
7. Lock washer for spring tension adjusting nut and also hub nut.
8. Spring tension adjusting nut.
9. Clutch hub nut (left thread).
10. Releasing disc and spring assembly.
11. Spring compression collar.
12. Sprung disc, to smooth clutch engagement.
13. Fibre disc.
14. Plain steel discs (two).
15. Lined discs (two).
16. Push rod steel washer.
17. Push rod cork oil seal spring.
18. Push rod cork oil seal.

Footnote: Spring compressing collars (6) are not furnished but can be easily made. They are not absolutely necessary to have, but make it possible to compress spring assembly and relieve tension on collar (11), when readjusting nut (8) or removing nut (9). If not available when taking clutch apart as in Illus. 8, turn just the nuts on two studs before removing nut (9). This will keep spring assembly together.

If clutch still does not hold, after making sure of correct control adjustment and increasing spring tension, it will have to be taken apart for inspection of discs. Possibly some of the discs will be found worn, or maybe only oil soaked and in need of washing and drying. See "Disassembling Clutch," this Page, and Page 17, and "Reassembling Clutch," Page 17.

## Adjusting Clutch Spring Tension

1941 to 1947 Models

(To Identify Items, Refer to Illus. 9)

If clutch slips, after control has been correctly adjusted, increase spring tension by tightening (turn right) the three nuts (4), after removing chain guard clutch cover and bending away locks (5). See footnote under Illus. 7.

Tighten all three nuts, one-half turn at a time until clutch holds. Test after each half turn by cranking engine. Usually a clutch that holds without any noticeable slippage when cranking engine, also holds on the road.

Do not increase spring tension any more than actually required to make clutch hold. As a new clutch is originally assembled and adjusted, the distance from inner edge of shoulder on spring collar (6) to outer surface of outer disc (8) is  $\frac{31}{32}$ ". In any case, do not tighten nuts (4) to the point where inner edge of shoulder on spring collar (6) is closer than  $\frac{55}{64}$ " to surface of outer disc (8). If compressed more, clutch probably cannot be fully released.

If clutch still does not hold, after making sure of correct control adjustment and increasing spring tension, it will have to be taken apart for inspection of discs. Possibly some of the discs will be found worn, or maybe only oil-soaked and in need of washing and drying. See "Disassembling Clutch," this Page, and Page 17, and "Reassembling Clutch," Page 17.

## Disassembling Clutch

1940 and Earlier Models

(To Identify Items, Refer to Illus. 8)

Remove outer chain guard. Remove the four nuts and washers that secure push rod thrust plate (5). However, unless springs may need inspection and possibly renewal, it is not necessary to release them. Install two compressing collars (6) or other suitable spacers and nuts on two opposite studs as shown in illustration, and tighten nuts sufficiently to relieve tension on collar (11). Before nut (9) can be turned, washer (7) will have to be straightened where it is set into slot in collar (11), to lock nut.

After removing nut (9) with Harley-Davidson special wrench, Part No. 12746-36, clutch will come apart as shown in illustration.

To remove clutch shell and sprocket, it is first necessary to remove engine sprocket (see paragraph 20 under "Removing Assembled Engine From Chassis For Complete Overhaul," Page 41). Then front chain and clutch sprocket assembly can be taken off.

Clutch hub with back plate is a taper fit on transmission mainshaft, and can now be removed with Harley-Davidson special puller, Part No. 12749-36.

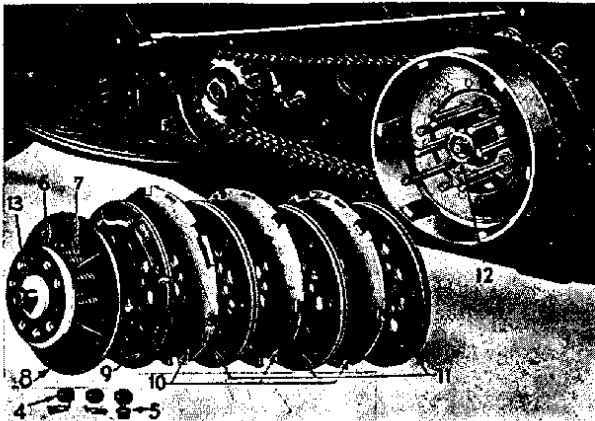

ILLUS. 9  
CLUTCH DISASSEMBLED (1941 TO 1947 MODELS)

4. Spring tension adjusting nuts (three).
5. Spring tension adjusting nut locks (three). See "Footnote."
6. Spring compression collar.
7. Clutch springs (ten).
8. Releasing disc.
9. Sprung disc, to smooth clutch engagement. Friction disc riveted to inner side.
10. Plain steel discs (three). Outside marked.
11. Lined discs (three).
12. Clutch hub nut (left thread).
13. Flat Washer—see Footnote.

Footnote: During the 1947 season, spring tension adjusting nut locks (5) were eliminated and adjusting nuts (4) were superseded by self locking nuts. Flat washer (13) used only when disassembling clutch.

## Disassembling Clutch

1941 to 1947 Models

(To Identify Items, Refer to Illus. 9 and 137)

Remove outer chain guard. Removing nuts (4) allows clutch (Items 2 to 11 inclusive) to come apart as shown in Illus. 137. However, unless springs may need inspection and possibly renewal, it is not necessary to release them. Spring collar (6), springs (7) and outer disc (8) can be removed as an assembly as shown in Illus. 9. This manner of disassembling makes reassembling a much simpler job than when springs are released.

To remove these parts, as an assembly, first obtain a flat washer (13), with approximately the following dimensions:  $\frac{1}{8}$ " thick,  $1\frac{3}{4}$ " outside diameter, and  $\frac{3}{8}$ " center hole. Remove push rod adjusting screw lock nut (3), Illus. 7, and install flat washer over adjusting screw (2), Illus. 7. Then turn lock nut onto adjusting screw, against washer and tighten lock nut until adjusting nuts (4) are free. Bend away nut locks (5), remove nuts (4) and assembly can be pulled off, freeing the other discs. See footnote under Illus. 7.

To remove clutch shell and sprocket, it is first necessary to remove engine sprocket (see paragraph

20 under "Removing Assembled Engine From Chassis For Complete Overhaul," Page 41). Then front chain and clutch sprocket assembly can be taken off.

Clutch hub with back plate is a taper fit on transmission mainshaft and is secured by nut (12) (left thread) and lock washer. To remove clutch hub, see "Removing Clutch Hub," Page 136.

## Reassembling Clutch

(Refer to Illus. 8, or 9 and 137)

Inspect all parts carefully.

If lined discs are not badly worn but are oil-soaked, wash them thoroughly in clean gasoline or solvent and dry with compressed air or heat. If discs are found worn to rivet heads, replace with new lined discs; it is impractical to reline old discs.

If clutch has been badly overheated as a result of slippage, and lined discs are found badly glazed and burned, and/or if clutch springs have shrunk as to length, such parts should be replaced.

Free length of new clutch springs is as follows:

1940 and Earlier Models: 2-7/16"

1941 to 1947 Models: 1-31/64"

Reassemble clutch in the reverse order of disassembly.

1940 and Earlier Models: Before installing and tightening clutch hub nut (9) turn nut (8) snug against flange on outer end of hub nut. Clutch hub nut and lock washer (7) can then be installed and nut securely tightened without compressing clutch springs further. After clutch hub nut has been securely tightened, lock it by upsetting edge of washer (7) into slot in spring collar (11).

1941 to 1947 Models: Be sure steel friction discs are assembled with sides stamped "OUT" facing outward. Also, splineways with anti-rattle devices should be staggered in clutch hub shell.

Be sure the three bearing plate retaining springs (29) are properly seated in their grooves in the three longer threaded studs (26). If springs are not seated in their grooves, or are placed on the short studs without grooves, clutch will not release properly.

All Models: After clutch has been reassembled, adjust clutch spring tension per instructions under "Adjusting Clutch Spring Tension," Page 16. With transmission installed in chassis, check and if necessary, readjust clutch control per instructions under "Checking and Adjusting Clutch Control," Page 15.

## FRONT WHEEL BRAKE ASSEMBLY

(Item Numbers Refer to Illus. 10)

ITEM	NUMBER USED	PART NUMBER	NAME
1	2	4040-36	Brake Shoe and Lining (same as Item 26)
2	2	4131-28	Brake Shackle Bushing (same as Item 4)
3	1	4130-40A	Brake Shackle
4	See Item 2		.....
5	1	0223	Brake Shackle Fork Stud Washer
6	1	0261	Lock Washer
7	1	0128	Brake Shackle Stud Nut
8	1	4118-36	Brake Shoe Pivot Stud
9	1	4059-35	Brake Shoe Pivot Stud Plate
10	1	0265	Lock Washer
11	1	0133	Brake Shoe Pivot Stud Nut
12	1	4182-36	Front Axle Sleeve
13	1	4116-36	Brake Side Cover Bushing
14	1	4109-36A	Brake Side Hub Washer (cork)
15	1	4109-36B	Brake Side Plate Spring
16	1	4109-36	Brake Side Hub Washer
17	1	4184-30	Axle Sleeve Nut
18	1	4054-36	Brake Operating Shaft
19	1	4055-31	Brake Operating Shaft Spring Washer
20	2	2964-35	Brake Shoe Spring (same as Item 21)
21	See Item 20		.....
22	1	4123-36	Brake Operating Lever (use inner clevis pin hole for solo service, outer clevis pin hole for sidecar service)
23	1	4124-36A	Brake Operating Shaft Washer
24	1	0262	Lock Washer
25	1	0129	Brake Operating Shaft Nut
26	See Item 1		.....
27	1	4108-41A	Brake Side Cover

NOTE: Items 1, 8, 9, 10, 11, 18, 19, 20, 21, 23, 24, 25 and 26 are the same for sidecar wheel brake.

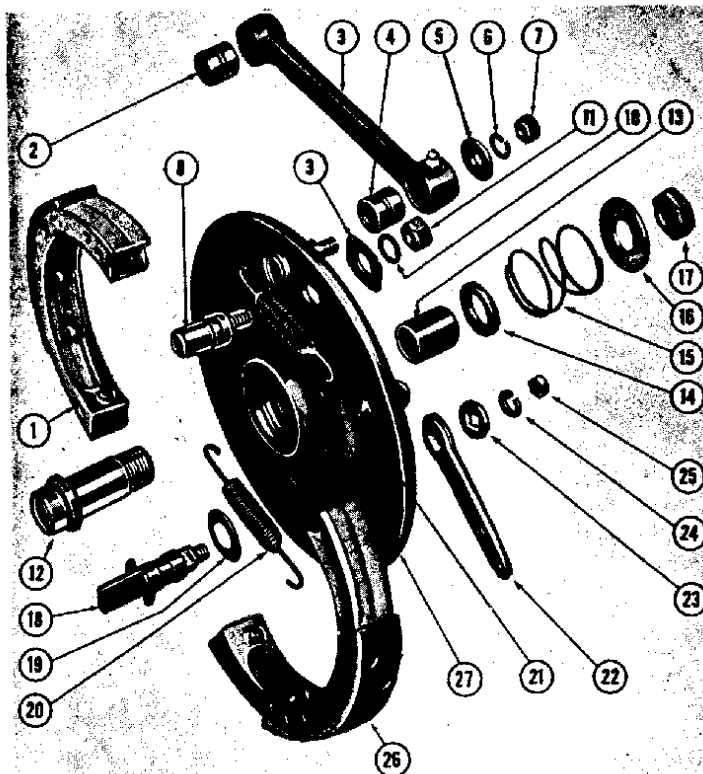

ILLUS. 10  
FRONT WHEEL BRAKE DISASSEMBLED

## REAR WHEEL BRAKE ASSEMBLY

(Item Numbers Refer to Illus. 11)

ITEM	NUMBER USED	PART NUMBER	NAME
1	1	4039-38	Brake Shoe and Lining (rear shoe)
2	1	0292	Cotter Pin
3	1	4058-38B	Brake Shoe Cup (outside)
4	1	4058-38A	Brake Shoe Cup (inside)
5	1	4058-38	Brake Shoe Pivot Stud
6	1	4036-37	Brake Side Cover
7	1	4059-35	Brake Shoe Pivot Stud Plate
8	1	0270	Lock Washer
9	1	2634-30A	Brake Shoe Pivot Stud Nut
10	1	4008-36	Rear Axle Sleeve
11	1	3961-30	Rear Axle Sleeve Collar
12	1	3963-30	Rear Axle Sleeve Nut
13	1	4054-37	Brake Operating Shaft
14	1	4055-31	Brake Operating Shaft Spring Washer
15	1	4037-37	Brake Operating Shaft Bushing
16	1	4050-30	Brake Shoe Spring
17	1	4056-36	Brake Operating Lever
18	1	0262	Lock Washer
19	1	0129	Brake Operating Shaft Nut
20	1	4038-38	Brake Shoe and Lining (front shoe)

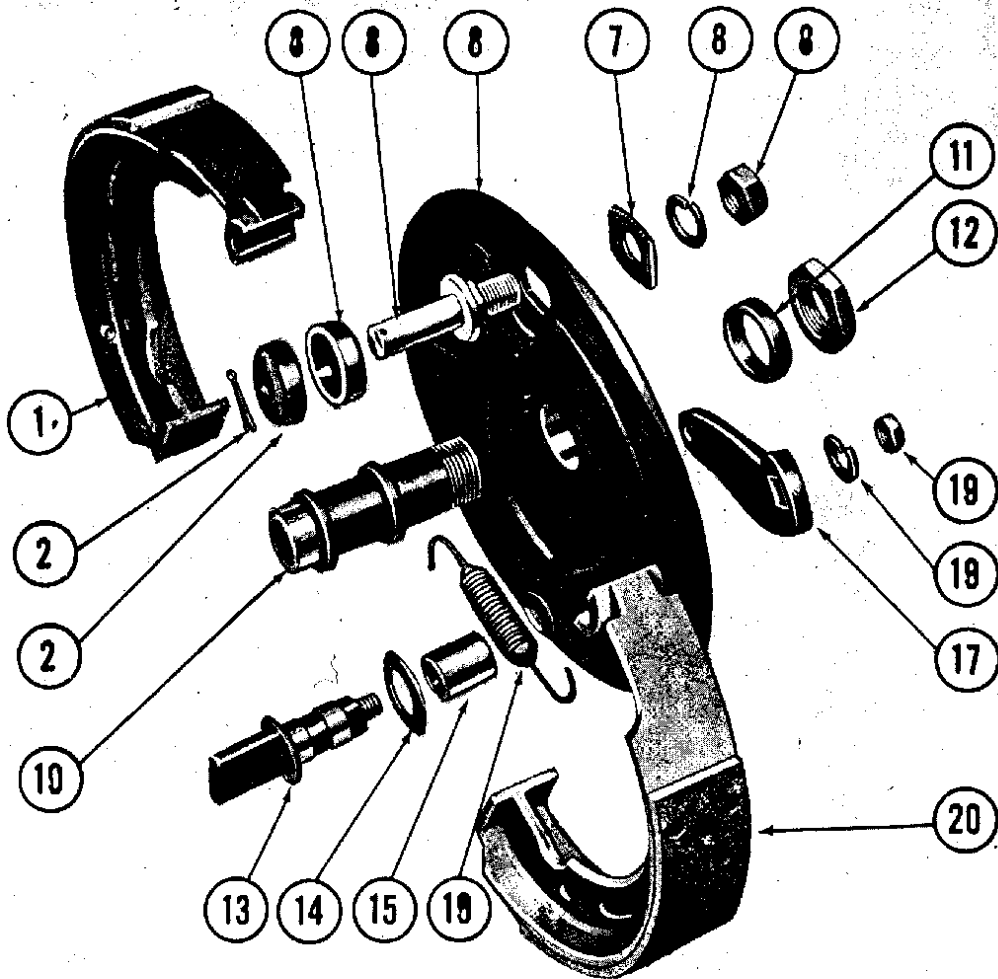

ILLUS. 11

REAR WHEEL BRAKE DISASSEMBLED

## ADJUSTING BRAKES

### Adjusting Front Wheel Brake

Loosen adjusting sleeve lock nut and turn adjusting sleeve as necessary to attain correct free movement of hand lever. After correct hand lever adjustment is made, tighten adjusting sleeve lock nut.

Properly adjusted, hand lever will move freely about one-quarter of its full movement before brake starts to take effect. Adjusted tighter brake may drag.

Keep brake control wire well oiled for easy operation.

### Adjusting Rear Wheel Brake

Loosen clevis lock nut on brake rod. Remove clevis pin from end of rear brake rod clevis and turn clevis as necessary to attain correct adjust-

ment.

Correctly adjusted, brake will not take effect until pedal is pushed down about an inch. Brake should take full effect at least an inch before pedal bottoms. Turn rear wheel to make sure brake is not too tight and dragging.

Note: If motorcycle is equipped with sidecar, see "Adjusting Sidecar Wheel Brake," before adjusting rear wheel brake.

### Adjusting Sidecar Wheel Brake

Disconnect sidecar brake rod (short rod) from brake shaft lever. Adjust rear wheel brake, see "Adjusting Rear Wheel Brake." After rear wheel brake has been correctly adjusted, adjust length of sidecar brake rod so when footpedal is operated, the rear brake starts to take effect slightly before sidecar wheel brake.

## SERVICING BRAKES

If a correctly adjusted brake does not function normally, new brake shoe linings and/or brake drum are usually needed, however, any worn or damaged parts that affect operation of brake must be renewed.

Remove wheel (see "Wheels, Hubs and Tires," Page 147).

To remove rear wheel brake shoes: (To identify items, refer to Illus. 11). Remove cotter pin (2) and brake shoe cup (3) from pivot stud (5). Pry brake shoes off pivot stud without removing shoe spring (16).

To remove front or sidecar wheel brake shoes: (To identify items, refer to Illus. 10). Place the end of a large screwdriver or other suitable tool between the ends of brake shoes at pivot stud (8) and pry ends of shoes off pivot stud without removing shoe springs (20) and (21). Shoe ends are registered in a groove in pivot stud.

Note: Sidecar wheel brake shoes, brake shoe springs, brake operating shaft and pivot stud, and the manner of assembling these items are the same as applies to "Front Wheel Brake Assembly," Illus. 10 and 12.

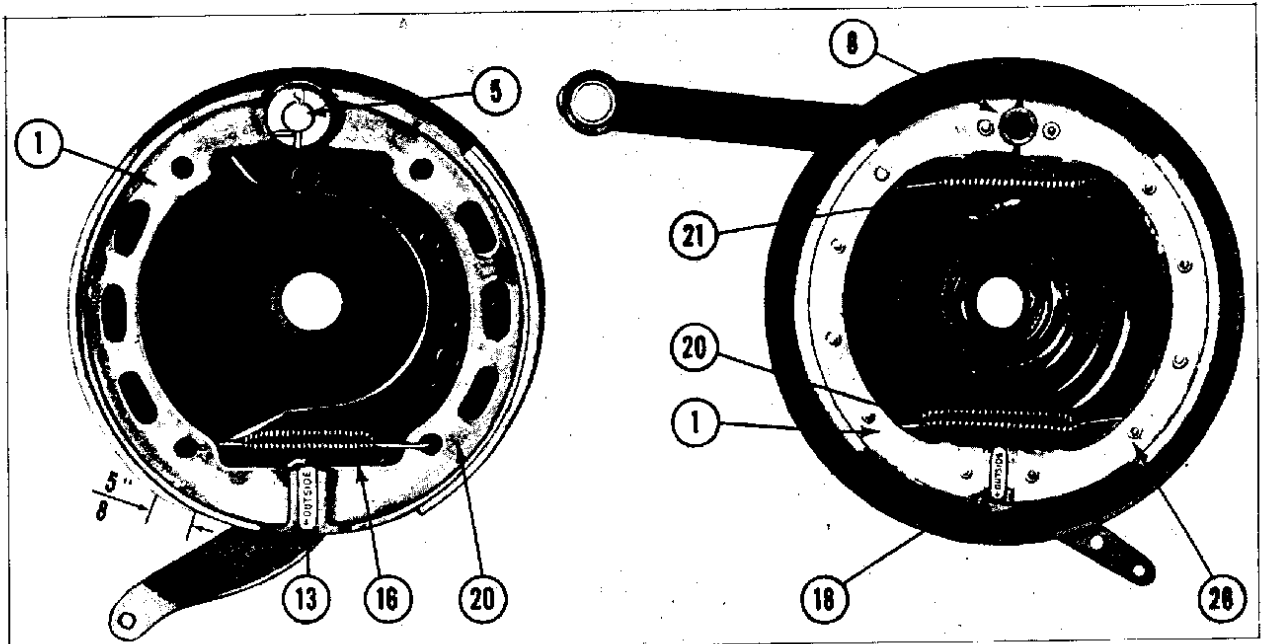

ILLUS. 12

FRONT AND REAR BRAKE ASSEMBLIES  
(To Identify Items Refer to Illus. 10 and 11)



**Relining brake shoes:** Clean and inspect all parts. If brake shoes are cracked or otherwise damaged they must be replaced. Brake shoe linings worn down to rivet heads, or impregnated with grease as a result of overgreasing wheel hubs, must be renewed. New linings can be riveted to shoes, or new shoes and linings can be installed.

Linings are the same for both shoes of front and sidacar wheel brakes.

Linings for rear wheel brake are the same for both shoes as received on parts order, however, after lining has been riveted to rear shoe, it must be beveled at lower end for a distance of  $\frac{3}{8}$ " as shown in Illus. 12. Rear shoe and lining assembly as received on parts order, has lining beveled at lower end.

When relining a shoe, start at one end and work to other end in order to make lining bear tightly

against shoe and not buckle in the middle. If a riveting machine is not available, set rivets with hand tools, making sure they draw lining tight against shoe.

After relining brake shoes, or fitting new brake shoes and linings, reassemble as shown in Illus. 12.

When installing brake operating shaft (13) or (18), be sure "arrow" points to outside as shown in Illus. 12.

Reinstall brake shoe springs (20) and (21) or (16) as shown in Illus. 12.

Install brake assembly and wheel in motorcycle, and loosen nut on pivot stud (5) or (8), Illus. 12. Apply brake hard and while holding it applied, tighten nut. This centers shoe assembly in brake drum. Adjust brake—see "Adjusting Brakes," Page 20.

## ADJUSTING CARBURETOR

(To Identify Items, Refer to Illus. 108)

Before attempting to correct faulty engine performance, attention should be given other items which have a direct bearing on, and can affect carburetor adjustment as well as engine performance.

A. See that throttle and spark controls are correctly adjusted.

B. Remove drain screw from bowl of carburetor. Drain and flush bowl to eliminate dirt and water.

C. Drain and flush gasoline strainer.

D. Check air cleaner to be sure passage of air through cleaner is not restricted by an excessive accumulation of dirt in filter element.

E. Check manifold packing nuts and carburetor mounting screws for tightness.

F. See that spark plugs are clean and correctly adjusted. If condition of spark plugs is questionable, install new ones.

G. Check adjustment of valve tappets.

H. Check compression of both cylinders by operating starter pedal slowly.

I. Check condition and adjustment of circuit breaker contact points.

J. Check for poor or loose connections in wiring, particularly at battery terminals, switch terminals and circuit breaker condenser.

K. Check battery to be sure it is not nearly discharged.

L. Check for intermittent short circuit due to damaged wiring insulation.

M. Check gasoline tank cap to be sure air vent is not plugged.

A carburetor once properly adjusted requires little, if any, readjusting. At the most, it should not be necessary to adjust the needles more than one or two notches richer or leaner to correct mixture for a change in weather conditions.

Both needles (2) and (3) turn down (to right) to make mixture "leaner" at the respective speeds for which they adjust. Backing them out (to left) makes mixture "richer." Both needles are held in whatever positions they may be turned to, by a spring and ball plunger which drops into notches in the needle adjusting screw.

A carburetor that is badly out of adjustment may be readjusted as follows: First, make sure carburetor control wire is adjusted so throttle fully closes and opens with handlebar grip movement. Turn both the low and high speed needles all the way down (to right). Then, back up (to left) low speed needle (3) about 5 turns, and high speed needle (2) about 2 turns. With needles in these positions, engine will start, but mixture will probably be too rich. Start engine and after choke lever has been moved to "open" position and engine is normally hot, correct the adjustment of both needles.

Adjust for low speed first. Turn low speed needle down (to right) one notch at a time until mixture becomes so lean that engine misses and is inclined to stop; then back needle up five to ten notches, or until engine hits regularly with spark advanced and throttle closed or as nearly closed as it can be set and still have engine run at idling speed. Next, adjust throttle lever stop screw (6) as may be necessary to make engine idle at proper speed with throttle fully closed. Turning screw to right makes engine idle faster. Turning screw to left makes engine idle slower. Don't idle an engine at the slowest possible speed, because an extremely slow idling adjustment causes hard starting. Since changing idling speed with throttle stop screw is likely to change low speed mixture to some extent, it will be necessary to again check and correct low speed needle adjustment by the same procedure followed in making the initial adjustment.

Starting and all-around carburetion will be better with low speed adjustment slightly rich rather than as lean as it can be made.

After low speed adjustments have been completed, run motorcycle on the road to check high speed adjustment. Run at various speeds between 20 miles per hour and wide open. Have spark fully advanced. If adjustment is too lean engine will stuff and back-fire through carburetor on quick throttle opening to accelerate from low speed. If adjustment is too rich engine will be sluggish and will lope and miss at intermediate and high speeds. Adjusting somewhat

over-rich is preferable to adjusting too lean, because a lean mixture causes overheating.

Best all around engine performance is usually found with high speed needle set as follows: O.H.V. Engine carburetor—model M-35 about 1 1/2 turns open, model M-25 about 1 1/4 turns open, model M-75 about 1 3/4 turns open; Side Valve Engine carburetor—model M-51 and M-51L about 1 1/2 turns open.

## ADJUSTING VALVE TAPPETS

### Adjusting Valve Tappets (O.H.V. Engine)

To get the maximum power and best all-around performance from an engine, keep valve tappets properly adjusted. They must be adjusted after grinding valves, and should be inspected and, if necessary, adjusted about every 1000 to 1500 miles thereafter.

The need of attention to tappet adjustment is indicated by excessive clicking and noise that develops with too much overhead rocker arm play, or in other words, too much clearance between valve rocker arms and ends of valve stems.

Engine must be cold.

To uncover tappets, press down on push rod cover

expander sleeve, and remove keeper at upper end. Cover then telescopes.

As each tappet is readjusted, first make sure it is at its lowest position, by turning engine ahead until the like tappet in the other cylinder is at its highest position (valve fully open).

The intake valves are those nearest the carburetor.

Adjust tappets so push rods have just noticeable play or shake, and can be turned freely with finger tips, completely around without any trace of bind.

When reassembling push rod covers, make sure that both ends of covers are properly seated against cork washers.

Unless a tight seal is maintained, valve spring covers will be flooded with oil, resulting in a bad oil leak around cylinder heads and also fouled plugs from excessive oil passing through valve guides into cylinders.

Each push rod cover is sealed with three cork washers, one at each end and one below expander sleeve and spring. Renew these washers if they show even slight damage or when more than very slight oil leakage develops around them. See "Installing Push Rod Cover Cork Washers," Page 23.

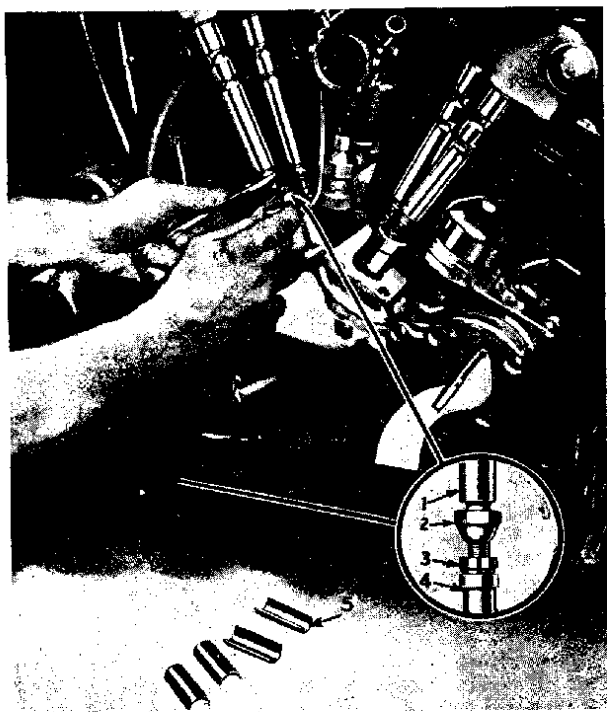

ILLUS. 13  
ADJUSTING VALVE TAPPETS (O.H.V. ENGINE)

1. Push rod.
2. Tappet adjusting screw—with which adjustment is made, after slightly loosening nut (3).
3. Tappet adjusting screw lock nut.
4. Tappet body.
5. Push rod cover keepers. (four)

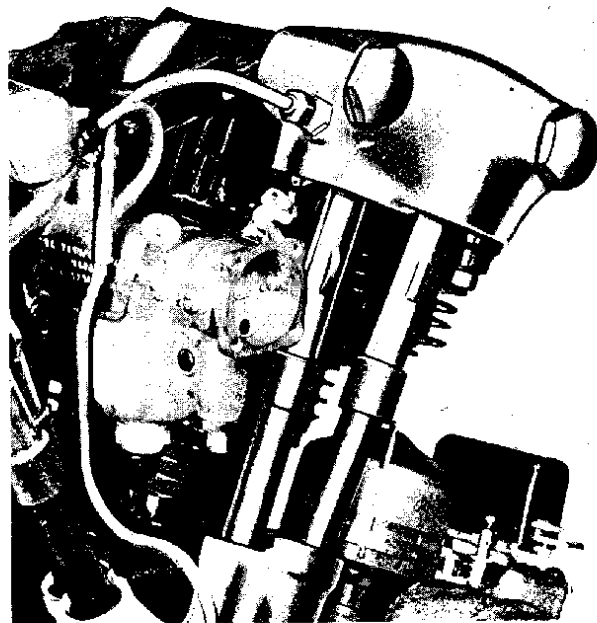

ILLUS. 14  
PUSH ROD COVERS ASSEMBLED (O.H.V. ENGINE)



## PUSH ROD AND COVER ASSEMBLY (O.H.V. ENGINE)

(Item Numbers Refer to Illus. 15)

ITEM	NUMBER USED	PART NUMBER	NAME
1	1	131-36	Valve Push Rod
5	1	142-40	Push Rod Cover Keeper
6	3	145-36	Push Rod Cover Cork Washer (same as Items 11 and 13)
7	1	134-36	Upper Push Rod Cover
8	1	138-36	Cover Expander Sleeve
9	1	140-36	Push Rod Cover Spring
10	1	146-36	Push Rod Cover Steel Washer
11	See Item 6	.....	.....
12	1	135-40	Lower Push Rod Cover
13	See Item 6	.....	.....

### Installing Push Rod Cover Cork Washers (O.H.V. Engine)

(To Identify Items, Refer to Illus. 13 and 15)

After tappets have been uncovered and inspection shows that any cork washers need renewing push rod and push rod cover assembly must first be removed.

1. Before attempting to remove push rod and cover assembly, turn engine until tappet is at its lowest position.
2. Turn adjusting screw lock nut (3) all the way up to end of thread on adjusting screw (2). Turn adjusting screw (2) all the way down into tappet body (4).
3. Remove push rod and cover assembly by prying push rod upward and to one side, but be careful not to bind push rod upper end in aluminum rocker arm housing, because doing so may result in a bent push rod.
4. Install cork washer (6) in aluminum rocker arm housing and cork washer (13) in tappet guide, being careful not to damage them and making sure they are well seated. Install cork washer (11) at upper end of lower push rod cover, as shown in Illus. 15.
5. Reassemble push rod and push rod cover assembly in reverse order of disassembly. See Illus. 14.
6. Readjust valve tappets—see "Adjusting Valve Tappets, (O.H.V. Engine)," Page 22.

### Adjusting Valve Tappets (Side Valve Engine)

To get the maximum power and best all-around performance from an engine, keep valve tappets properly adjusted. They must be adjusted after grinding valves, and should be inspected and, if necessary, adjusted about every 1000 to 1500 miles thereafter.

The need of attention to tappet adjustment is indicated by excessive clicking and noise that develops with too much clearance between tappets and ends of valve stems.

Engine must be cold.

To uncover tappets, first lift cover spring ring with Harley-Davidson special spanner, Part No. 11959-39 (one furnished in each tool kit), and latch it in slots in upper spring cover. Keeper can then be removed and lower cover telescoped into upper cover.

As each tappet is adjusted, first make sure it is at its lowest position, by turning engine ahead until the like tappet in the other cylinder is at its highest position (valve fully open).

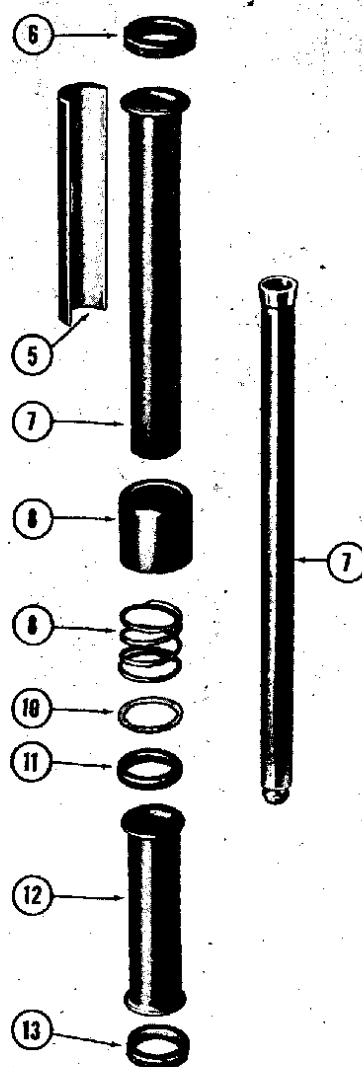

ILLUS. 15  
PUSH ROD COVER DISASSEMBLED

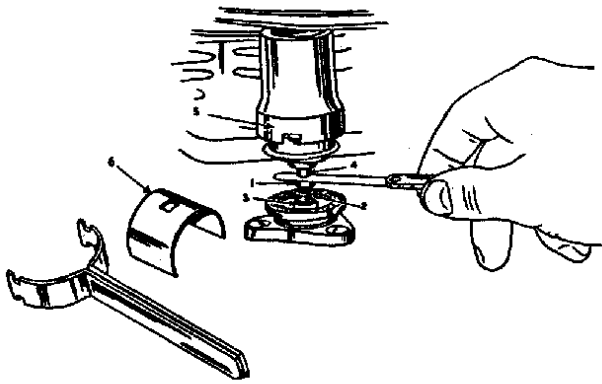

ILLUS. 16  
ADJUSTING VALVE TAPPETS (SIDE VALVE ENGINE)

1. Tappet adjusting screw—with which adjustment is made, after slightly loosening nut (2).
2. Tappet adjusting screw lock nut.
3. Tappet Body.
4. Valve stem.
5. Valve spring upper cover.
6. Valve spring cover keeper.

The intake valves are those nearest the carburetor.

Adjust tappets so that there is .004" to .005" clearance between intake valve stems and tappets, and .007" to .008" clearance between exhaust valve stems and tappets. An accurate thickness gauge should be used to measure these clearances. If no gauge is available, use one thickness of ordinary writing paper to gauge intake tappet clearance, and two thicknesses of the same paper to gauge exhaust tappet clearance.

Before replacing valve spring covers, inspect the cork washer between each lower cover and tappet guide. If broken or damaged, install a new washer to prevent an oil leak. Also, make sure spring covers are properly seated against cork washers. Otherwise, serious oil leakage will result.

## STEERING DAMPER

Steering damper applies steering friction to steady front wheel and prevents wobble in rough going and at higher speeds. For all normal service, keep handle in left side (free) position; move handle to right to apply desired friction.

Assemble in the order shown in Illus. 17. Be sure torque arm engages properly with frame head. Lips on pressure disc must fit into slot in fork crown and slot in rod lock plate. Turn actuating sleeve down and then back it up  $\frac{1}{2}$  turn or slightly more. Install

operating lever with handle extending to rear and see if actuating sleeve bottoms when handle is moved to left side position  $90^\circ$  from rear position. If actuating sleeve does bottom remove operating lever and back sleeve up another  $\frac{1}{2}$  turn.

Adjust by setting adjusting nut so that operating lever must be moved nearly straight back from free (left side) position, before damper takes noticeable effect. Tighten lock nut.

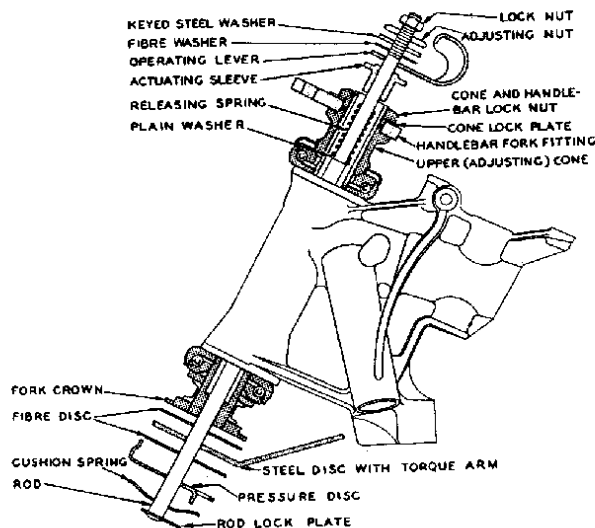

ILLUS. 17  
STEERING DAMPER ASSEMBLY

## SERVICING HANDLEBAR CONTROLS

(To Identify Items, Refer to Illus. 19)

To lubricate control parts, or to replace a throttle or spark control wire, or a damaged control wire housing, proceed as follows:

Disconnect control wire at carburetor or circuit breaker. Insert a large heavy screw driver through hole in end of grip as shown in Illus. 18 and turn out end screw (A) by using a wrench on screwdriver. Sometimes this screw is difficult to remove. In this case, insert a punch in slot in screw and strike it two or three sharp blows to start it. After removing grip sleeve assembly (C), working parts are accessible. Remove roller (E), roller block (F), and roller pin (D). Plunger (G), with control wire (H) attached, can now be pulled out of handlebar end. If wire is broken, remove other half from housing at connection end. Wire is fastened into end of plunger by means of a hexagon head screw (I) with a hole through it.

Remove any rust, dirt or gum from grip spiral, handlebar end, wire plunger, and inside of handlebar where plunger operates.

If control wire housing is to be removed, first remove grip control parts as explained above. Then, remove the small lock screw underneath handlebar, just ahead of spiral locating shoulder on bar (on left bar, this screw is under headlamp dimmer switch). After lock screw is removed and housing freed from housing clamp or clamps, it can be pushed out through end of handlebar.

When installing control wire housing, see that housing end is secured in handlebar with lock screw (screw must register in groove in control coil plug) and that housing is secured with clamp or clamps.

When reassembling control parts to handlebars, apply a light coat of grease or a few drops of engine oil to control wire as it is inserted into control housing, and lubricate remaining parts with grease (see "Lubrication Chart," Page 9). Overgreasing of these parts will cause a messy condition.

End screw (A) can best be started, without danger of crossing threads, by holding grip sleeve assembly

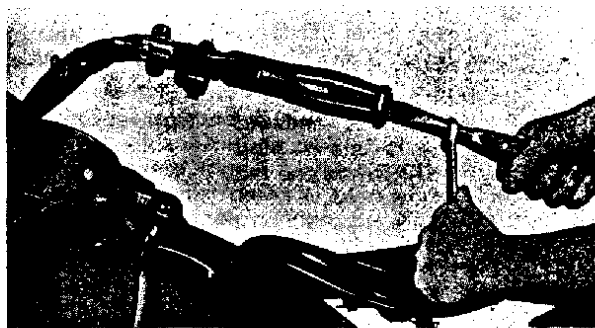

ILLUS. 18  
REMOVING HANDLEBAR GRIP SLEEVE ASSEMBLY

(C) back with slight pressure against screw while starting screw in handlebar end. This squares screw with end of grip sleeve, aligning threads. Always tighten screw securely.

After throttle and/or spark controls are completely assembled, connect control wire at carburetor and/or circuit breaker.

Adjust throttle control so throttle closes and opens fully with throttle control grip movement. There should be about 1" to 1½" between end of throttle control wire housing and throttle lever when lever is in fully closed (forward) position.

With circuit breaker in fully advanced position, be sure end of spark control wire points directly to hole (in which it is to be secured) in advance and retard lever—1946 and Earlier Models; or timing adjusting stud—1947 Models.

O.H.V. Models: Allow about ½" of spark control wire housing to extend beyond clamp. Side Valve Models: allow about 2" of spark control wire housing to extend beyond clamp.

All Models: Adjust spark control wire so circuit breaker advances and retards fully with spark control grip movement.

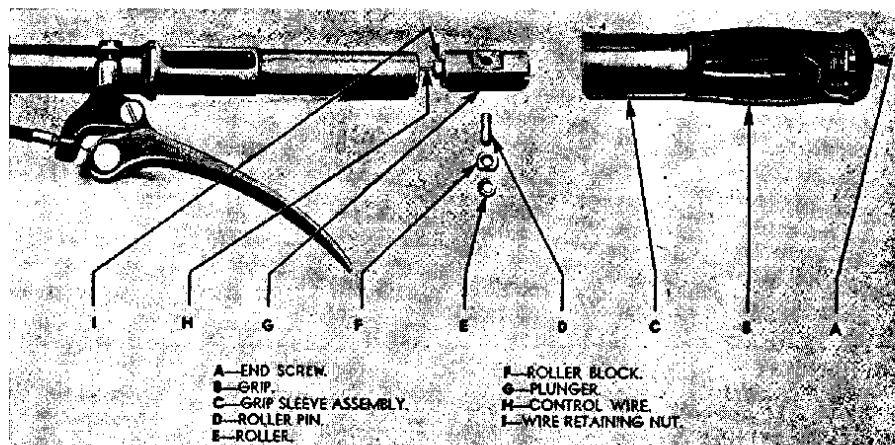

ILLUS. 19  
CONTROL GRIP DISASSEMBLED

## REPLACING FRONT BRAKE CONTROL CABLE

Remove control cable lower clevis clamp nut and pull cable out of clevis. Next, remove cotter pin and flat washer from handlever hollow pin and pull pin out of lever. Control cable can now be pulled out of housing.

Insert new control cable in housing (at handlever end). Make sure lower end of cable is inserted through adjusting sleeve. Apply grease or engine oil to new cable as it is being inserted. Handlever hollow pin must be reassembled before lower end of cable is connected. Narrow slot in pin straddles cable. Replace flat washer and cotter pin at end of hollow pin.

Pull cable taut making sure control cable housing is seated in recess in handlever bracket and in adjusting sleeve and that handlever is tight against its bracket. With cable pulled taut, insert it through cable clamp nut, through clevis and back through nut and adjust cable so there will be  $1\frac{1}{4}$ " of cable between end of adjusting sleeve and end of clevis. Holding cable in this position, install cable clamp nut on clevis and tighten nut securely. Cut off excess wire.

Adjust control, by means of adjusting sleeve, so that handlever moves freely about one-quarter of its full range of movement before brake begins to take effect. Tighten adjusting sleeve lock nut.

## SERVICING SADDLE SPRING POST

(To Identify Items and Part Numbers, Refer to Illus. 20)

Spring combinations with part numbers that make up saddle spring post assemblies, Part Nos., 3122-36, 3123-36, 3121-36, 3123-36A, 3125-36, are listed.

New motorcycles are furnished with standard saddle spring post assembly unless other than standard is specified on order.

The illustration shows following parts of saddle spring post assembly:

1. Spring tension adjusting nut.
2. Adjusting nut lock nut.
3. Rod nut lock nut.
4. Rod nut.
5. Post clamp nut.
6. Saddle post rod.
7. Spring guide collars.
8. Plunger nut.

After raising saddle, remove saddle post clamp nut (5), which is located underneath frame at bottom end of post tube. Post assembly can then be pulled out.

To disassemble saddle spring post, remove nuts (1, 2, 3, and 4), cushion springs and collars (7). Remove nut (8) from plunger and then saddle post rod (6) and upper springs are free for removal. To re-

assemble, reverse operations of disassembly. To adjust cushion spring assembly (three lower springs), loosen lock nut (2) and turn adjusting nut (1) to right to increase spring tension; to left to decrease spring tension. If, however, considerable change in spring tension is required, a different set of springs to suit weight of rider will be required. Refer to Illus. 20 to determine spring combination needed.

Saddle spring post assemblies, Part Nos. 3121-36 and 3123-36A, use same spring combination but adjustment of cushion spring assemblies differs as shown in illustration.

When post assembly is inserted in frame tube, see that flat side machined on post rod nut (4) registers in flat side of hole in bottom of tube.

Ordinarily saddle spring post assembly will not need lubrication other than that given with grease gun at intervals given in Lubrication Chart. See "Lubrication Chart," Page 9.

If, however, spring combination is changed, any springs replaced, or springs and other parts cleaned, initial lubrication should be given by applying a liberal amount of Harley-Davidson grade "A" grease to springs and other moving parts.

---

### Memoranda

---

---

---

---

---

---

---

---

---

---

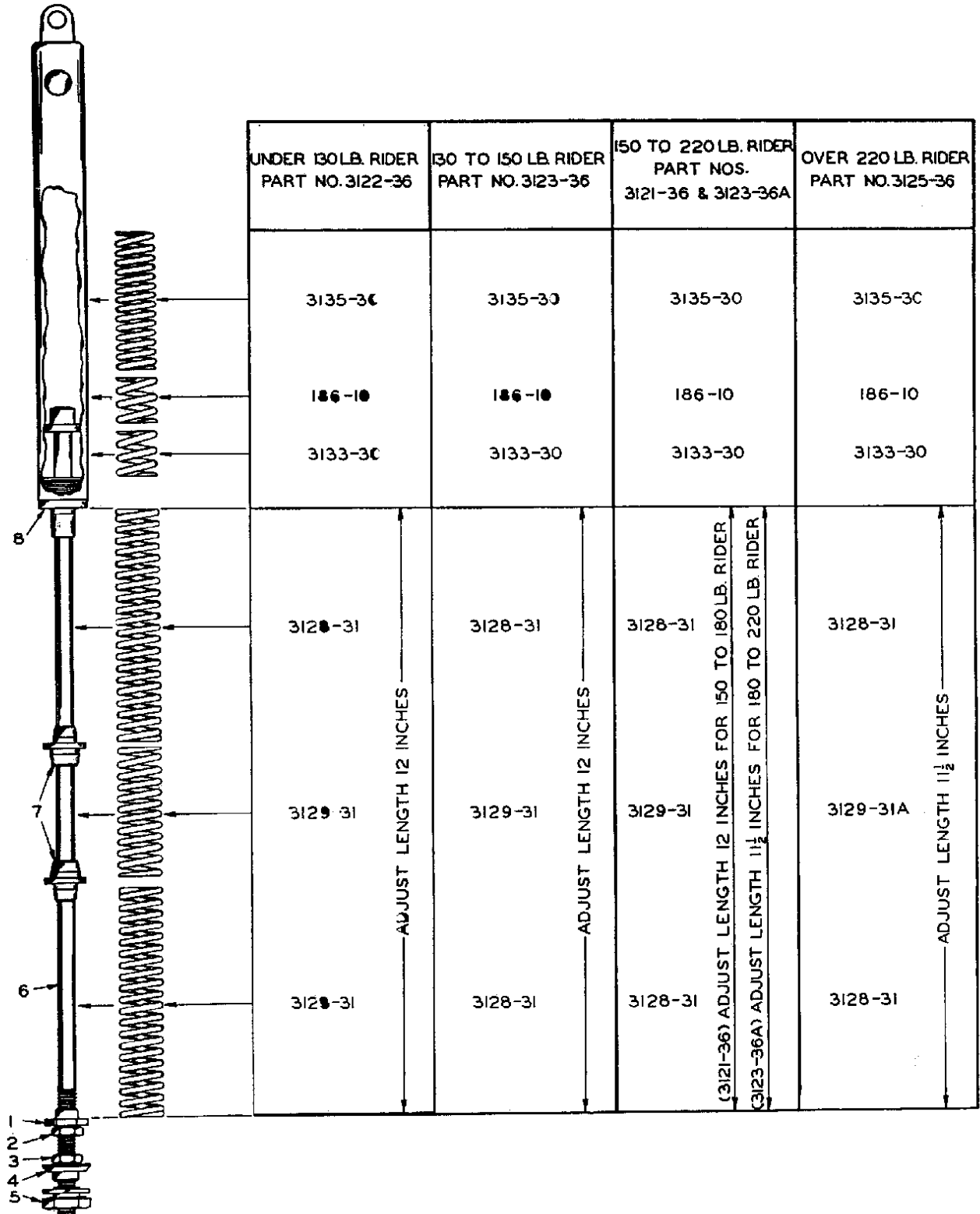

ILLUS. 20  
 SPRING SADDLE POST ASSEMBLY  
 Standard Assembly (150 to 180 lb. Rider) Par. No. 3121-36.



## ADJUSTING OIL FEED PUMP

Standard factory setting of maximum pressure adjusting screw is as follows:

**1940 O.H.V. Model:** (To identify item (14), refer to Illus. 56). End of adjusting screw (14)  $\frac{3}{8}$ " from outer end of valve chamber. Average maximum oil pressure at this setting is about 15 lbs.

**1941 to 1947 O.H.V. Models:** (To identify item (14), refer to Illus. 56). End of adjusting screw (14)  $\frac{3}{8}$ " from outer end of valve chamber. Average maximum oil pressure at this setting is about 30 lbs.

**1940 and earlier Side Valve Models:** (To identify item (2), refer to Illus. 57.) Adjusting screw (2), nine full turns open. Turn adjusting screw all the way down until it bottoms lightly against valve. Don't force it. Then back up screw nine full turns. Average maximum oil pressure at this setting is about 20 lbs.

**1941 to 1947 Side Valve Models:** (To identify item (2), refer to Illus. 57). End of adjusting screw (2)  $\frac{3}{8}$ " below top of pump body. Average maximum oil pressure at this setting is about 35 lbs.

**All Models:** Turning adjusting screw to right increases oil pressure; turning adjusting screw to left decreases oil pressure.

Note: Maximum oil pressure varies considerably with hot or cold oil.

## REMOVING AND INSTALLING OIL PUMP WITH ENGINE INSTALLED IN CHASSIS (O.H.V. Engine)

(To Identify Items, Refer to Illus. 56)

### Removing Oil Pump

1. Remove stop lamp switch and oil pressure switch. Remove oil return pipe. Remove oil feed pipe and install nipple cap, Part No. 3583-15 on oil tank feed pipe nipple to prevent oil from running out, or drain tank.
2. **1940 Model pump** is secured to crankcase by six nuts—after removing the six nuts, remove pump cover and gasket; **1941 and later Model pump** is secured by one cap screw, one flat head screw and five nuts, one of the nuts is extra long to provide wrench clearance and its location should be noted, so it will be put back on same stud when reinstalling pump—after removing nuts and screws, remove pump cover (29), governor rotor (28), cover plate (26) and gaskets (25) and (27).

**All O.H.V. Models:** Unless new gaskets are available, be very careful not to damage or break the old ones. These are special gaskets as concerns both thickness and holes for oil passages. It is not advisable to attempt to replace them with "home-made" gaskets. Leaving out a hole or getting one in the wrong location is enough to put the entire oiling system out of commission. When

new gaskets are needed, they should be replaced with "factory-made" gaskets.

3. Place a small piece of rag or paper in feed oil hole in bottom of pump body to prevent gear key dropping into hole should it fall out of drive shaft when removing scavenger pump gear (23). Remove lock ring (24) from groove in outer end of shaft and slide gear off shaft. Remove key (21) from drive shaft. Pump body can now be pulled off studs.

Remove feed pump idler gear (5) if it did not come off with pump body.

Slide feed pump gear (6) off shaft and remove key from shaft—occasionally gear will come off with pump body, in which case be careful key is not lost. After gear and key have been removed from shaft, be sure shaft is pulled outward to its limit. If shaft is pushed inward approximately  $\frac{3}{8}$ ", key in end of shaft inside gear case may drop out and gear case cover would then have to be removed to install key. See "Servicing Oil Pump (O.H.V. Engine)," Pages 71 and 72.

### Installing Oil Pump

1. Be sure all moving parts of oil pump are thoroughly oiled. Clean surface of pump body mounting on crankcase. See that pump body gasket is in good condition, and install it over pump mounting studs. Clean face of oil pump body.
2. Install smaller of the two keys in drive shaft keyway (nearest crankcase) and install feed pump gear (6) so keyway registers with key. Install feed pump idler gear (5) with hub of gear registering in hole counterbored in crankcase.
3. Install pump body making sure the small piece of rag or paper put in oil feed hole in bottom of pump body when removing pump, is still in place to prevent possibility of key dropping into hole should it fall out of shaft when installing scavenger pump gear. Make sure feed pump gear (6) is snug against crankcase when installing pump body, to prevent possibility of key dropping out of shaft.

**1941 and later Model Pump:** Install flat head screw that secures pump body to crankcase.

4. **All O.H.V. Model Pumps:** Install larger of the two keys in drive shaft keyway (near outer end) and install scavenger pump gear (23) so keyway registers with key. Install new lock ring in groove at outer end of shaft to retain gear. Install scavenger pump idler gear (22).

**CAUTION: AFTER GEARS HAVE BEEN INSTALLED BE SURE TO REMOVE CLOTH OR PAPER FROM FEED OIL HOLE IN PUMP BODY.**

**1940 Model Pump:** Install cover gasket, cover, nuts and washers. **1941 and later Model Pump:** Install gasket, cover plate, gasket, governor rotor, cover, nuts, cap screw and washers. Make sure driving tongue on rotor (28) registers in slot in scavenger pump idler gear (22).

5. Tighten cap screw and/or nuts securely.
6. Install oil return pipe (connecting lower end of pipe to pump upper nipple). Install oil feed pipe (connecting lower end of pipe to pump lower nipple) and tighten nipple nuts securely.
7. Install oil pressure switch and stop lamp switch.

## REMOVING AND INSTALLING OIL FEED PUMP WITH ENGINE INSTALLED IN CHASSIS

### (Side Valve Engine)

(To Identify Items, Refer to Illus. 57—Also Refer to Illus. 21)

#### Removing Oil Pump

1. Remove oil feed pipe and install nipple cap, Part No. 3583-15, on oil tank feed pipe nipple to prevent oil from running out, or drain tank. Disconnect oil feed pipe from oil pump nipple.
2. Oil pump is secured to engine gear case cover by one cap screw (11) and three nuts (9, 12 and 13). Two of the nuts are extra long to provide wrench clearance, and their location should be noted so they will be put back on same studs when reinstalling pump. After removing screw and nuts, remove pump.

Unless a new gasket (21) is available be careful not to damage or break the old one. This is

a special gasket as concerns both thickness and holes for oil passages. It is not advisable to replace it with a "home-made" gasket. Leaving out a hole or getting one in the wrong location is enough to put the entire oiling system completely out of commission. When a new gasket is needed it should be replaced with "factory-made" gasket.

See "Servicing Oil Feed Pump (Side Valve Engine)," Pages 72 and 73.

#### Installing Oil Pump

1. Be sure all moving parts of oil pump are thoroughly oiled. Clean surface of pump body mounting on gear case cover. See that gasket is in good condition, and install it over pump mounting studs. Clean face of pump body.
2. Start pump on mounting studs, turn engine slowly and press lightly against pump until driving dogs on end of cam gear shaft line up with and drop into driving slot in oil pump rotor (17).
3. Install cap screw and lock washer, and install the three lock washers and nuts (two are extension nuts) on pump mounting studs. Make sure to replace the two extension nuts on the studs from which they were originally removed.
4. Tighten cap screw and three nuts securely.
5. Install oil feed pipe and tighten nipple nuts securely.

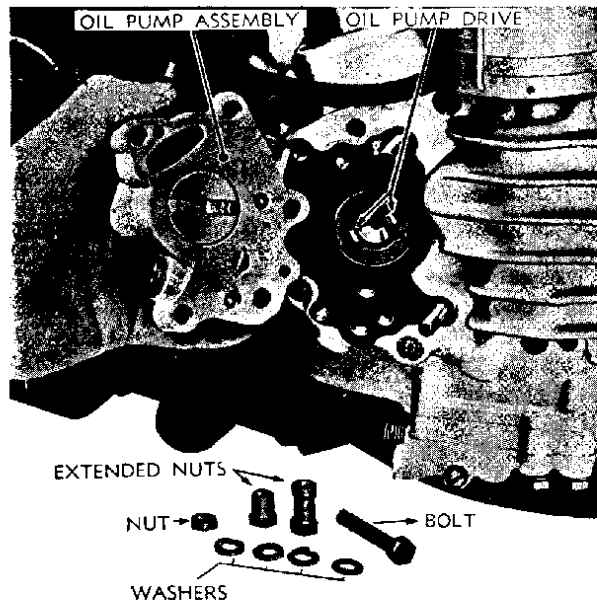



ILLUS. 21  
OIL PUMP REMOVED (SIDE VALVE ENGINE)



## LEGEND FOR ILLUS. 22 AND 23— O.H.V. ENGINE OILING AND BREATHER SYSTEM

- A. Feed section of oil pump.
- B. Check valve.
- C. Maximum oil pressure regulating valve.
- D. Governor rotor with centrifugal valve which controls oil pressure at low and intermediate speeds.
- E. Front chain oiler adjusting screw.
- F. Scavenge section of oil pump.

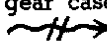
G. Pinion gear shaft through which oil is forced to connecting rod lower bearings, from which it splashes to cylinder walls, pistons, main bearings, etc.

H. Timed "Rotary" crankcase breather valve. Rotary breather valve is timed to open on downward stroke of pistons, allowing crankcase exhaust air to expel scavenge oil from crankcase into timing gear case. This interval is indicated by arrows . During this interval, the two small ports in breather valve are closed. Rotary breather valve closes on upward stroke of pistons, creating vacuum in crankcase. During this interval both small ports in breather valve line up with passages in crankcase. Oil is then retrieved by vacuum from outside breather oil trap (J) in crankcase, and valve spring covers as indicated by arrows .

J. Outside breather oil trap.

K. Crankcase oil scavenging sump.

 Feed oil from tank to engine. Oil is forced through passages as indicated, to connecting rod lower bearings, and through passages and pipe to rocker arms, push rods, and valve stems.

 Scavenge oil (return oil) from engine to oil tank. Oil is pumped from engine through passages as indicated.

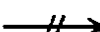
 By-pass oil. Surplus oil over and above the volume required to attain the pressure to which pump is adjusted, escapes past

pressure regulating valve (C) and, flowing through passage indicated, discharges directly into timing gear case where it lubricates timing gears, and then settles into scavenger pump sump from which it is returned to tank.

 Oil retrieved by vacuum. As oil accumulates in valve spring covers and outside breather oil trap (J) in crankcase, it is retrieved by crankcase vacuum through passages and push rod covers as indicated.

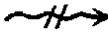
 Scavenge oil and crankcase exhaust air from crankcase sump (K). Exhaust air expels scavenge oil from crankcase, through rotary breather valve (H), into timing gear case where the oil settles into scavenger pump sump and is returned to tank.

 Crankcase exhaust air. Escapes from timing gear case through outside breather passage, which terminates in front chain guard. Any oil still carried by exhaust air is trapped in outside breather oil trap (J) and retrieved by vacuum.

 Front chain oil. Oil is bled from by-pass oil for front chain lubrication, through passages indicated which terminate in outside breather passage. Exhaust air delivers oil to chain. Oil is regulated by adjusting screw (E).

Note: Oil to rocker arms and valve stems is metered through a fixed orifice in each rocker arm shaft and no adjustment for more or less oil is provided.

**CAUTION:** Since oil supplied to overhead fittings is sucked back into crankcase through push rod covers by crankcase vacuum, it is essential that push rod covers and rocker arm housings be well sealed to maintain maximum vacuum and prevent oil leakage. When reassembling push rod covers, make sure that both ends of covers are properly seated against cork washers.

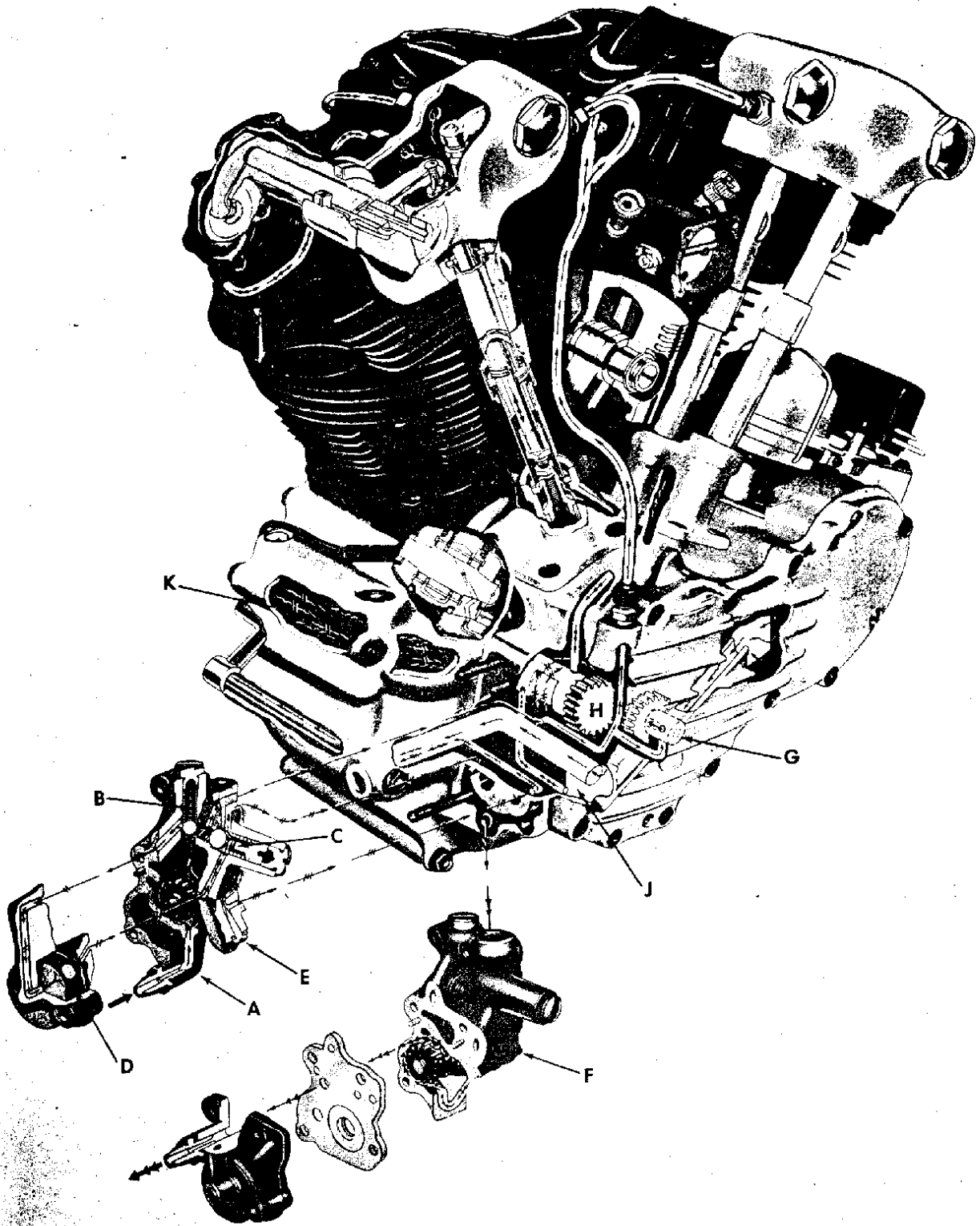

ILLUS. 22  
OILING SYSTEM (O.H.V. ENGINE)

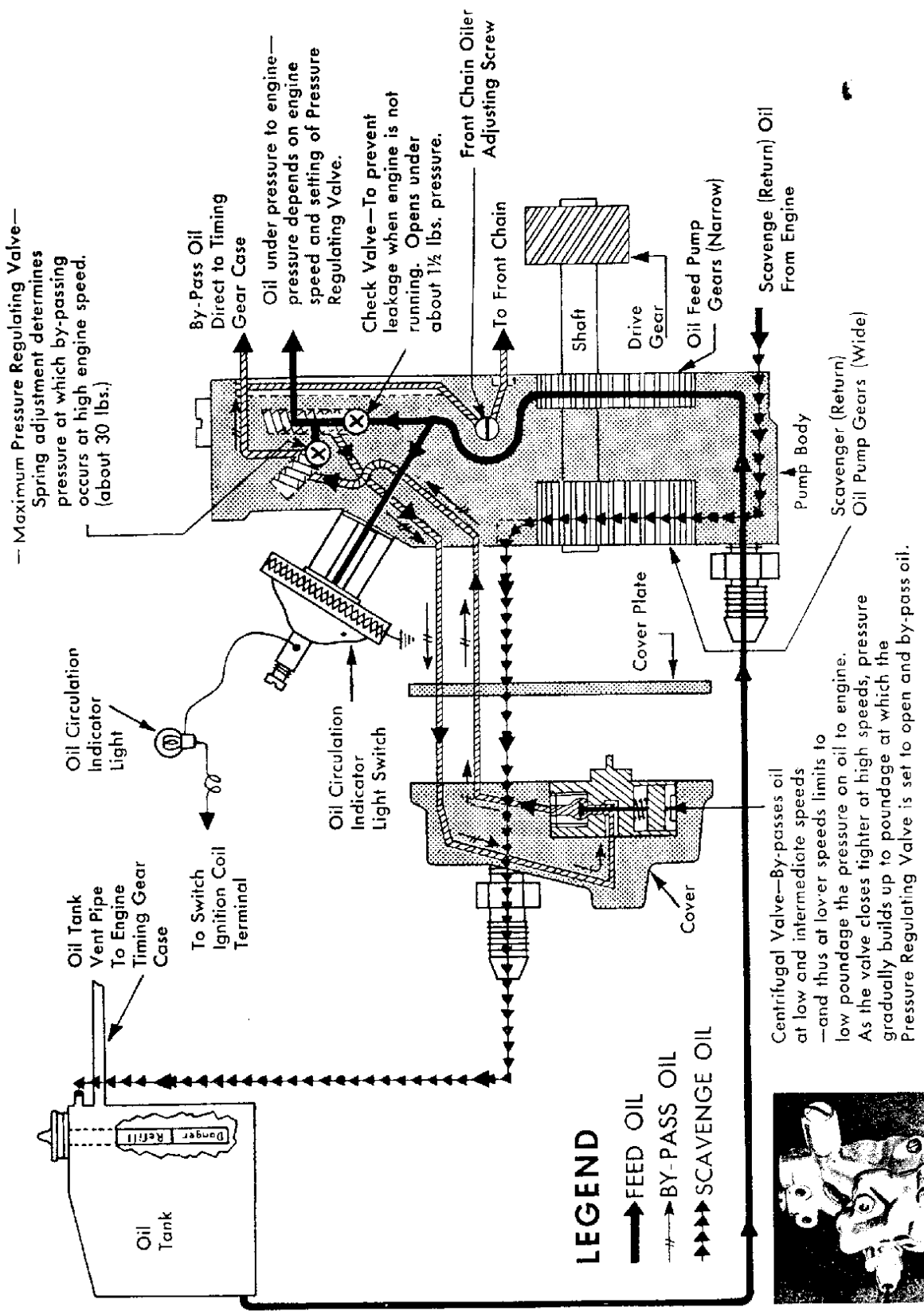

**SCHEMATIC DIAGRAM OF OIL PUMP FOR 1941 & Later 61" & 74" O.H.V. MODELS.**

ILLUS. 23

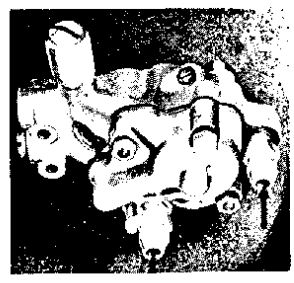

## ENGINE LUBRICATION

Engine lubrication is a circulating system. A gear-type feed pump (O.H.V. Engine) or a vane-type feed pump (Side Valve Engine), draws oil from the tank and delivers it to crankshaft under pressure. Pressure can be regulated.

A gear-type scavenger pump returns oil from engine base to tank.

**O.H.V. Engine:** Refer to schematic diagram of oil pump, Illus. 23, and engine oiling system, Illus. 22.

**Side Valve Engine, 1940 and Earlier Models:** Refer to schematic diagram of oil feed pump, Illus. 25, and engine oiling system, Illus. 24.

**Side Valve Engine, 1941 to 1947 Models:** Refer to schematic diagram of oil feed pump, Illus. 26, and engine oiling system, Illus. 24.

A motorcycle engine being air cooled requires a high quality lubricating oil.

**O.H.V. Engine:** Use Harley-Davidson "Medium Heavy" oil above +10° F.; Harley-Davidson "Light" oil, when predominating temperature is +10° F. or colder.

**Side Valve Engine:** Use Harley-Davidson "Regular Heavy" oil above +32° F.; Harley-Davidson "Medium Heavy" oil +32° F. to +10° F.; Harley-Davidson "Light" oil when predominating temperature is +10° F. or colder.

**All Models:** If winter weather becomes so extremely cold that "Light" oil congeals in tank, add just enough kerosene to keep oil fluid.

Tank completely empty holds one gallon. About one inch from top of tank is considered full. Don't fill above this level, as tank needs some air space. Tighten cap securely to prevent leakage.

Oil circulation is indicated by oil signal light in instrument panel going "OFF" when engine is running.

Oil mileage normally varies from 250 to 500 miles per quart depending on nature of service, solo or sidecar use, fast or moderate driving, and condition of engine as regards both timing and wear. If mileage is not within this range, engine may need attention, or oil pump may need adjusting, see "Adjusting Oil Feed Pump," Page 28.

Remove oil tank cap (gauge rod attached) and check oil supply not more than 300 miles after each complete refill. Unless oil is added to bring tank oil level to full mark each time oil is checked, more frequent checking than 300-mile interval mentioned above will be necessary to avoid any chance of tank running dry.

When level is down to "refill" mark, 2 quarts can be added. Oil supply runs cooler and mileage somewhat higher with oil level well up in tank.

When a new engine has run its first 750 miles, and normally in warm or hot weather and in average service, at about 2000 mile intervals thereafter, completely drain oil tank of used oil and refill with fresh oil. If service is extremely hard, or dusty service on dirt roads or in competition, drain and refill at shorter intervals. Draining should be done after a run while oil is hot. It is not necessary to drain crankcase as it does not accumulate used oil. At the time of the first 750-mile oil change, and at least with every second oil change thereafter, thoroughly flush and clean out oil tank with kerosene. This will remove any sediment and sludge that may have accumulated.

**Winter Caution:** Water is a by-product of combustion in any internal combustion engine. In a condensed state, the water vapor formed would equal approximately the quantity of gasoline burned. Some of this water vapor escapes past the rings into the crankcase. When starting and warming up in cold weather, especially in freezing or colder weather, considerable of the vapor that gets into crankcase condenses to water before crankcase is hot enough so that it no longer acts as a condenser and exhausts the vapor, without inside condensation, through outside breather. If engine is driven enough to get crankcase thoroughly warmed up frequently, most of this water is again vaporized and blown out through outside breather. However, a moderately driven engine, making only short runs now and then and seldom thoroughly warmed up, is likely to accumulate an increasing amount of water in oil tank. This water will, in freezing weather, become slush or ice and, if allowed to accumulate too long, may block oil lines with resulting damage to engine. Also, water mixed with oil for some time, forms a heavy sludge of considerable acid content that is very harmful to bearings and other internal engine parts.

To sum it up briefly, an engine that is used only for short runs during freezing weather requires frequent oil changes along with thorough flushing of tank to remove any accumulated sludge.

Therefore, in winter the oil change interval should be shorter than normal for all engines, and any engine used only for short runs, particularly in commercial service, must have oil changed frequently along with a thorough tank flushout to remove any water and sludge, before new oil is put in tank. The farther below freezing the temperature drops, the shorter the oil change interval should be.

---

Note: The following three pages of schematic diagrams of Harley-Davidson Side Valve Engine oiling

system, and oil feed pumps will enable you to trace feed oil and return oil in this type of engine.

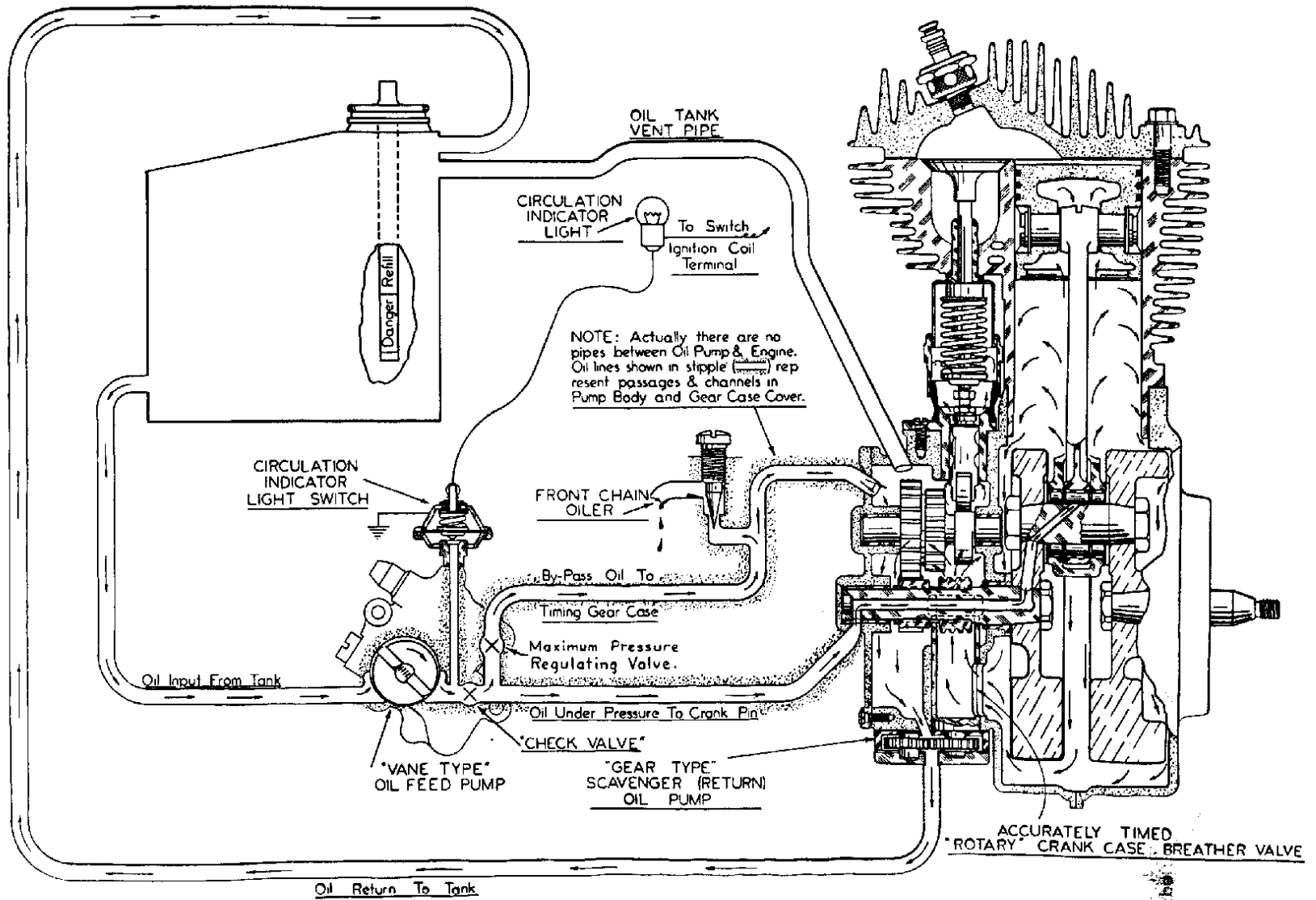

<http://maniacschematic.com> **SCHEMATIC DIAGRAM**  
**74" & 80" SIDE VALVE ENGINE OILING SYSTEM**

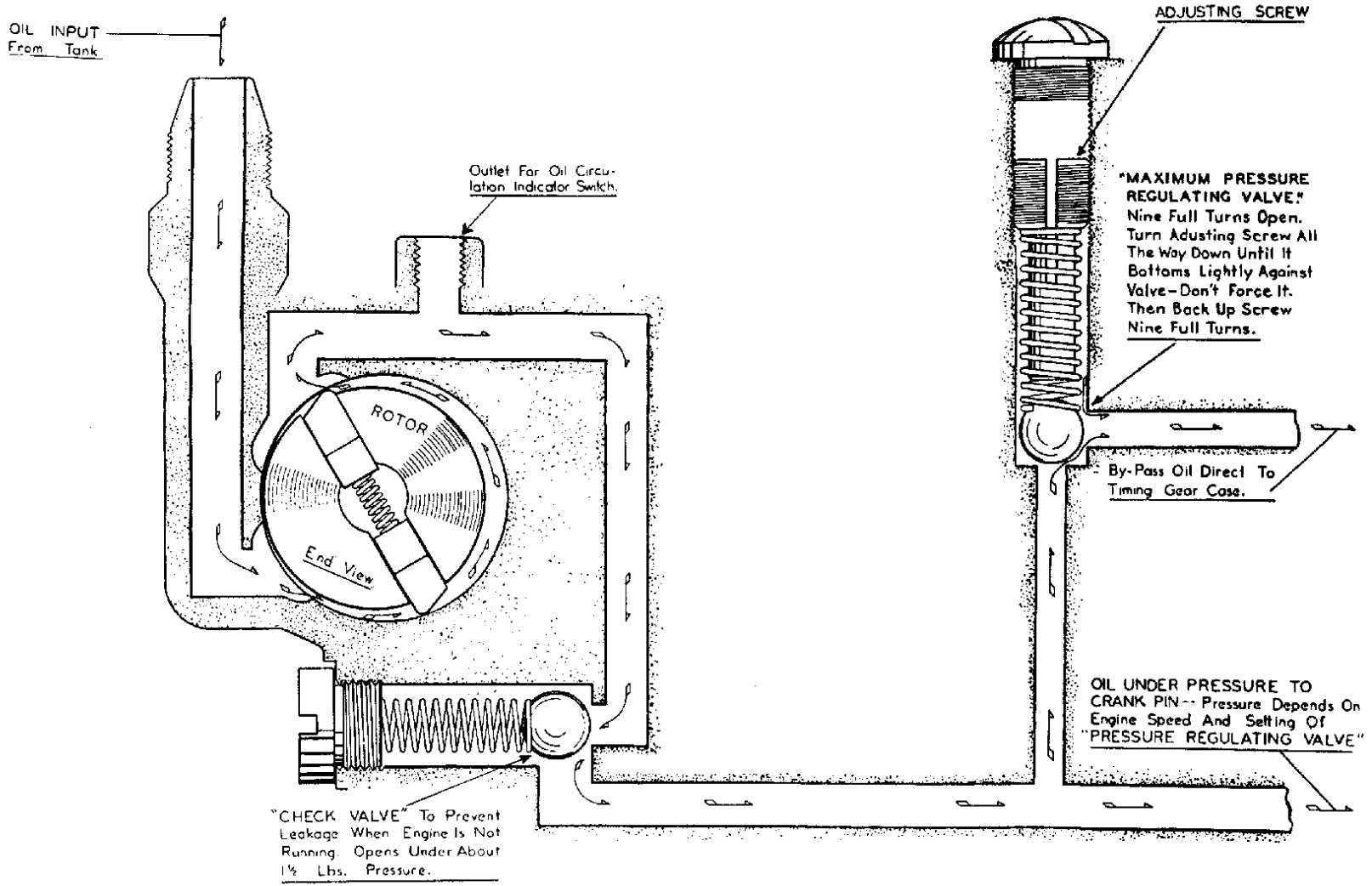

35

**SCHEMATIC DIAGRAM**  
**1940 AND EARLIER**  
**74- & 80-SIDE VALVE ENGINE**  
**OIL FEED PUMP**



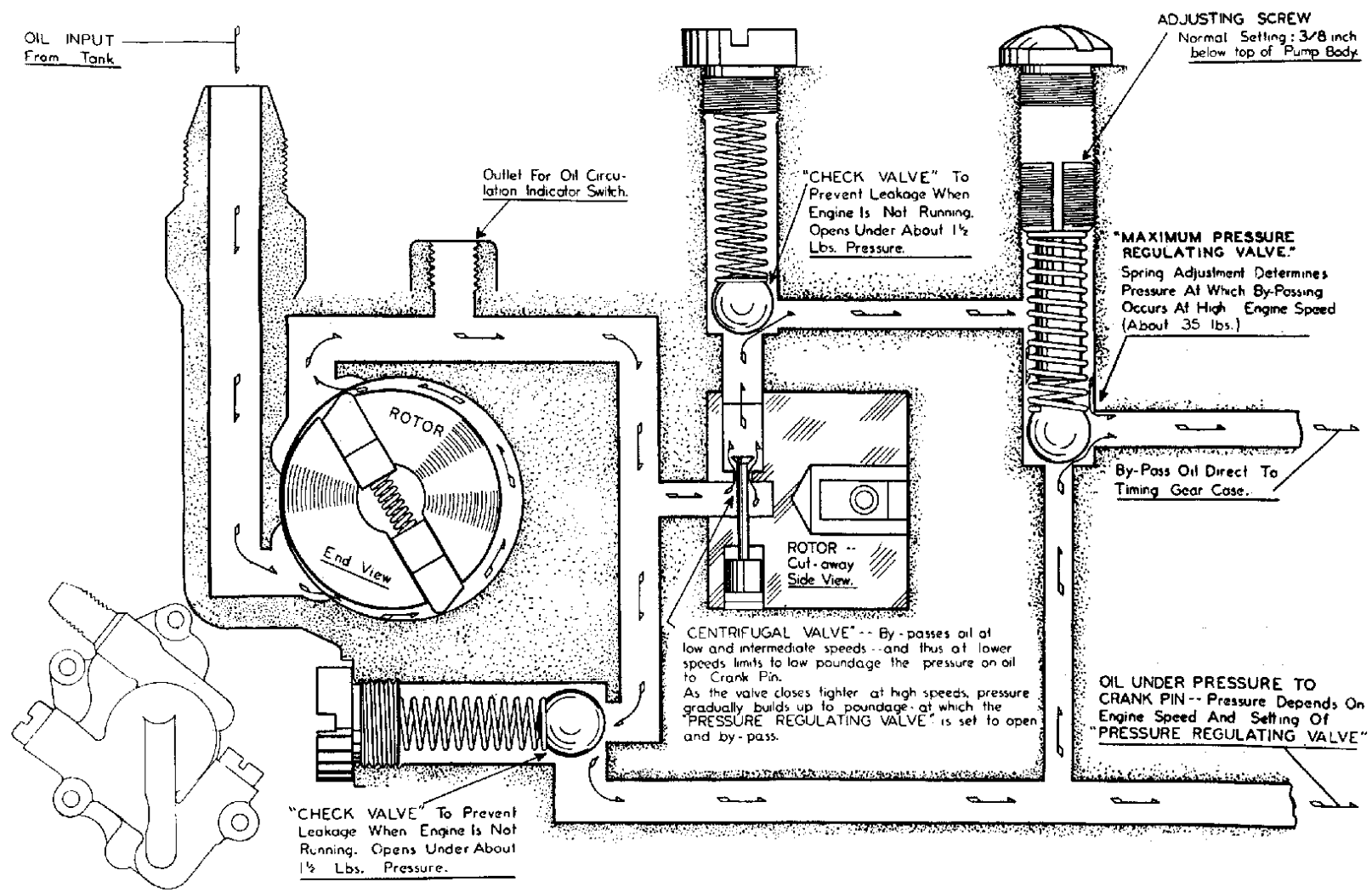

**SCHEMATIC DIAGRAM  
1941 AND LATER**

74" & 80" SIDE VALVE ENGINE

**OIL FEED PUMP**



## OVERHAULING ENGINE

When an engine needs repair, it is not always possible to definitely determine beforehand whether repair can be made with only upper end disassembled for top overhaul or whether engine must be completely disassembled for lower end repair.

Most commonly, only upper-end repair is needed (valves, rings, pistons, etc.) and it is recommended procedure to first disassemble upper end only, allowing engine base to remain in frame and following procedure outlined under "Disassembling Engine for Top Overhaul Only."

After disassembling upper end only, it may be found that lower end repair is necessary; this requires removal of engine base from frame as outlined under "Removing Engine Base for Overhaul," Page 40.

In cases where it has been definitely determined beforehand that lower end repair is necessary, engine, completely assembled, should be removed from frame as outlined under "Removing Assembled Engine From Chassis for Complete Overhaul," Page 41.

### DISASSEMBLING ENGINE FOR TOP OVERHAUL ONLY

#### Disassembling O.H.V. Engine

(If motorcycle is used with sidecar or package truck, remove it.) First perform operations 1 to 8 inclusive, under "Removing Assembled Engine From Chassis for Complete Overhaul," Page 41.

9. Remove oil pipe at rocker arm housings and gear case cover.
10. Remove manifold and carburetor: If motorcycle is equipped with oil bath air cleaner, disconnect air intake hose connection fitting from carburetor and leave attached to hose. Remove air cleaner bracket together with oil bath air cleaner and hose.

Remove nut securing carburetor support bracket to crankcase top center bolt. Unscrew manifold nuts, using Harley-Davidson special wrench, Part No. 12002-40.

11. Open push rod covers. Press cover expander sleeves down and remove push rod cover keepers. Telescope lower push rod cover over upper cover.
12. Remove cylinder heads: Turn engine until both valves are closed in front cylinder head. Remove cylinder head bolts, using Harley-Davidson special wrench, Part No. 12650-29. Remove front cylinder head, valve push rods and push rod covers in one operation. Follow practically the same procedure to remove rear cylinder head except after head bolts have been removed, twist head to left to free valve push rods and push rod covers. There is not enough clearance between rear head and frame to allow lifting head straight up as is the case with front head. Mark push rods in some manner to identify

them as to which cylinder head and valve they were taken. If push rods are reinstalled in same locations from which they were removed, a minimum amount of valve adjusting should be necessary.

Note: If the cylinder heads do not come loose on removal of head bolts, tap lightly with rawhide hammer under aluminum rocker arm housing bracket to loosen. Never try to pry head off.

13. Clean crankcase around cylinder bases and push rod covers to prevent dirt from falling into crankcase when lifting cylinders.
14. Remove cylinders: Remove all cylinder base stud nuts, except one on rear cylinder, using Harley-Davidson special wrench, Part No. 12050-30. Raise front cylinder and piston just high enough to permit placing a rag over crankcase opening; this will prevent dirt and possibly pieces of broken ring from falling into crankcase. With piston at bottom of stroke remove cylinder. Remove remaining stud nut from rear cylinder and remove rear cylinder in same manner front was removed. See "Checking Connecting Rod Lower Bearing for Excessive Wear and Looseness," Page 40; "Piston and Pin," Page 88; "Emergency Piston and Ring Service," Page 87; "Installing and Fitting Connecting Rod Upper Bushing," Page 90.
15. Strip cylinder heads: Remove screws and cover plates from spring covers. With screws removed, the straight screw plates are free to come off.

Compress valve springs using Harley-Davidson special valve spring compressor, Part No. 12630-36 and remove valve keys from ends of valve stems. Upper and lower valve spring collars, springs and valves can then be removed. It is customary to reassemble valves in same cylinder head from which they were removed; therefore, before removing, mark them in some manner to identify them with front and rear cylinder head.

Check valve guides and valve stems for wear. See "Valve Guides (O.H.V. Engine)," Page 46, and "Valves," Page 46.

If oil seals or valve guides do not need replacing, or rocker arms or shafts do not need attention, no further stripping of heads will be necessary. If in addition to servicing valves and seats, oil seals and/or valve guides need removing, remove remaining nuts and washers that secure rocker arm shafts in their brackets and the cap screws that secure aluminum rocker arm housings to cylinder heads. Drive rocker arm shafts very carefully out of their brackets to free assembly.

Disassemble rocker arm shafts, rocker arms and oil seals. Note order in which oil seals, washers and other parts are assembled in housings and reverse disassembling procedure when reassembling. See "Reassembling Cylinder Heads (O.H.V. Engine)," Page 52.

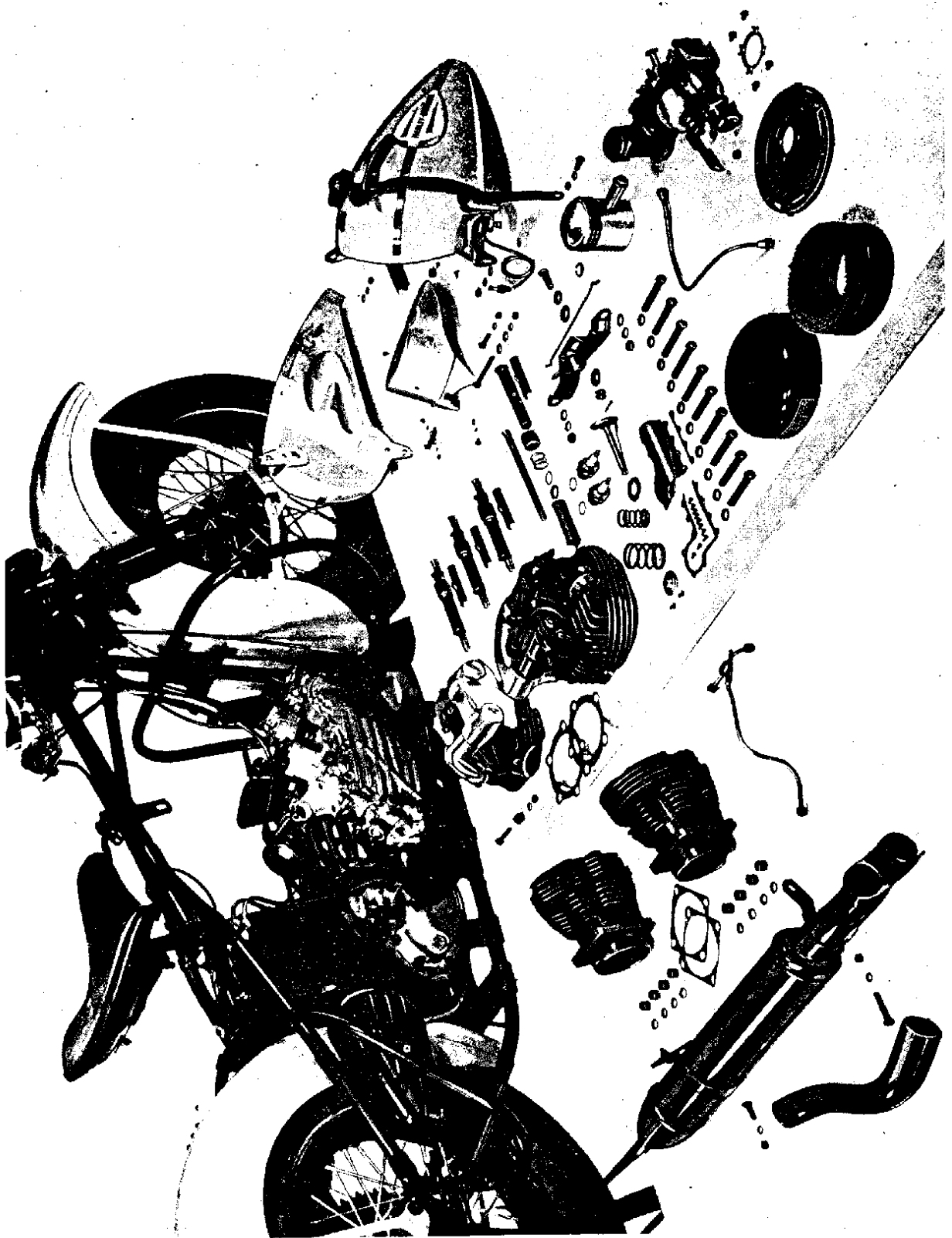

ILLUS. 27  
DISASSEMBLED FOR TOP OVERHAUL (O.H.V. ENGINE)

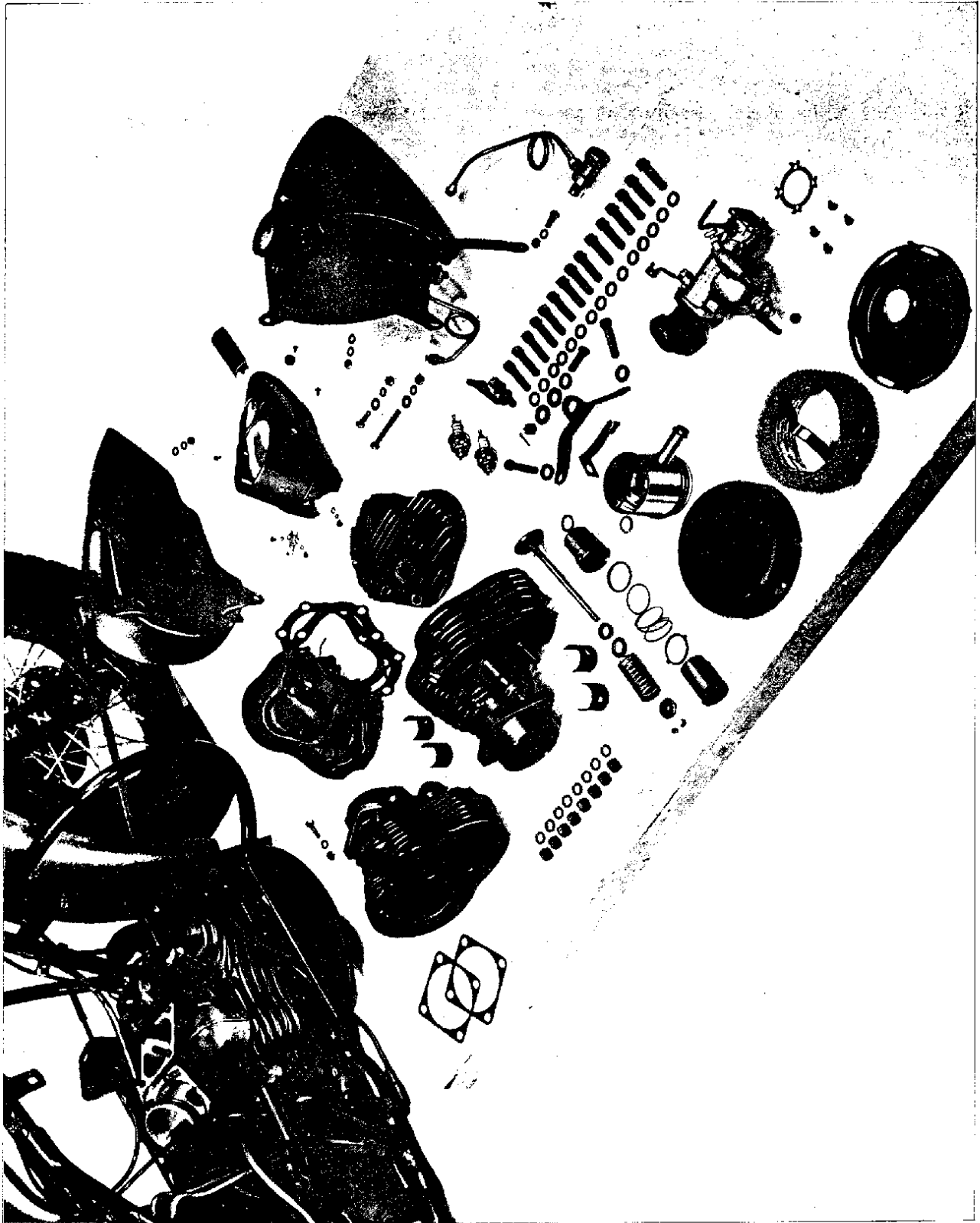

ILLUS. 28  
DISASSEMBLED FOR TOP OVERHAUL (SIDE VALVE ENGINE)

## Disassembling Side Valve Engine

(If motorcycle is used with sidecar or package truck, remove it.) First perform operations 1 to 8 inclusive, under "Removing Assembled Engine From Chassis for Complete Overhaul," Page 41.

9. Disconnect spark control wire at circuit breaker and free spark control wire housing from front cylinder base stud.
10. Free front exhaust pipe clamp and work pipe as far out of cylinder as possible. If motorcycle is used with sidecar, or package truck, lower front connection socket tie rod must be removed to free front exhaust pipe.
11. Remove cylinder heads: Use Harley-Davidson special wrench, Part No. 12047-30H.
12. Remove manifold and carburetor: If motorcycle is equipped with oil bath air cleaner, disconnect air intake hose connection fitting from carburetor and leave attached to hose. Loosen hose at air cleaner and remove hose with fitting. Remove nut securing carburetor support bracket to crankcase top center bolt. Unscrew manifold nuts, using Harley-Davidson special wrench, Part No. 12002-30, and remove manifold with carburetor attached.
13. Clean crankcase around cylinder bases and valve covers to prevent dirt from falling into crankcase when lifting cylinders.
14. Raise valve covers: Lift cover spring ring with Harley-Davidson special tool, Part No. 11959-39 and latch ring in slots in upper spring cover. Keeper can then be removed and lower cover telescoped into upper cover.
15. Remove cylinders: Turn engine until both valves are closed in front cylinder. Remove all cylinder base stud nuts, except one on rear cylinder, using Harley-Davidson special wrench, Part No. 12050-30. Raise front cylinder and piston just high enough to place rag over crankcase opening; this is to prevent dirt and possibly pieces of broken rings from falling into crankcase. With piston at bottom of stroke, lift front cylinder free.

After making sure valves are closed, remove remaining stud nut and washer from rear cylinder and remove rear cylinder in same manner as front. See "Checking Connecting Rod Lower Bearing for Excessive Wear and Looseness;" "Piston and Pin," Page 88; "Emergency Piston and Ring Service," Page 87; "Installing and Fitting Connecting Rod Upper Bushing," Page 90.

16. Strip cylinders: Compress valve springs, using Harley-Davidson special valve spring compressor, Part No. 12053-30, and remove valve keys from ends of valve stems. Valve collars, springs, spacers, valve covers and valves can then be removed (see Illus. 29). It is customary to reassemble valves in same cylinder from which they were removed; therefore, before removing, mark them in some manner to identify them with front and rear cylinder.

Check valve guides and valve stems for wear. See "Valve Guides (Side Valve Engine)," Page 46, and "Valves," Page 46.

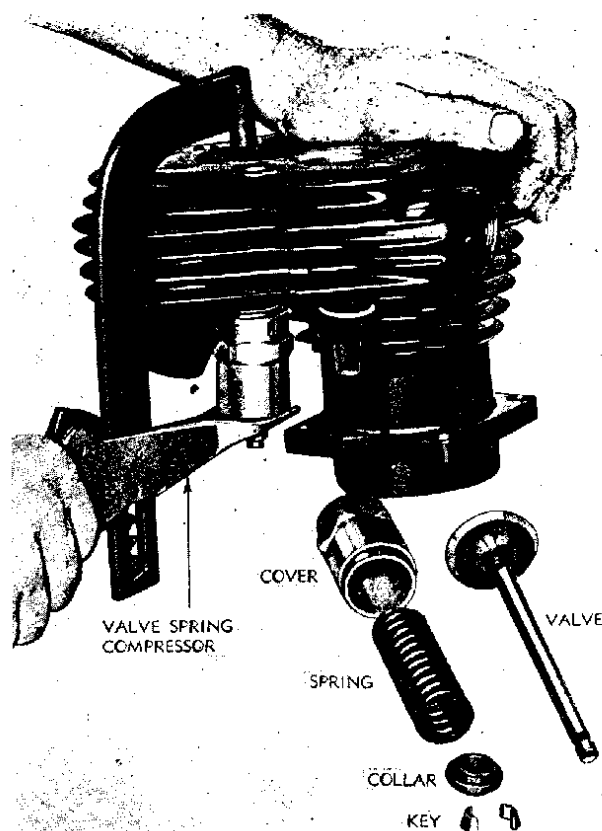

ILLUS. 29  
REMOVING VALVES (SIDE VALVE ENGINE)

## Checking Connecting Rod Lower Bearing For Excessive Wear and Looseness

Check rods for up and down play and upper end side shake (see Illus. 30). To make this check with accuracy, pistons should first be removed. When appreciable up and down play is found and either or both rods have  $3/32$ " or more side shake at extreme upper end, lower bearing should be refitted. This requires removing and disassembling engine base.

Of course, in connection with emergency piston and ring service, which is usually a service job that, under the circumstances, can be done only well enough to take an engine through a further short period of use, after which it is to be completely overhauled as needed, somewhat more than normal maximum lower end looseness should be allowed to pass.

## Removing Engine Base for Overhaul

After first disassembling for top overhaul and finding that base also needs attention, perform operations 9 to 23 inclusive, for O.H.V. Engine, or operations 10 to 23 inclusive, for Side Valve Engine, under "Removing Assembled Engine From Chassis for Complete Overhaul," Page 41.

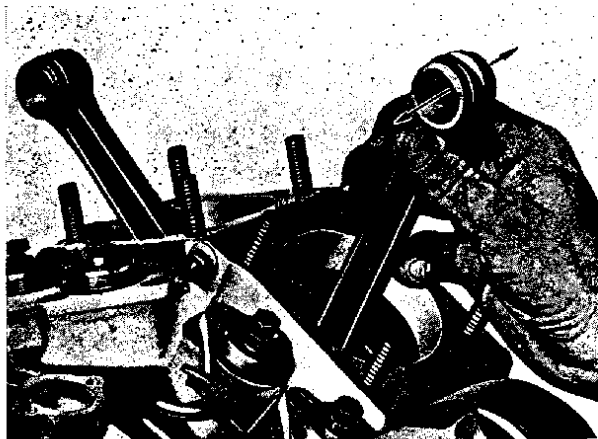

ILLUS. 30

CHECKING CONNECTING ROD FOR BEARING WEAR

## REMOVING ASSEMBLED ENGINE FROM CHASSIS FOR COMPLETE OVERHAUL

When it is obvious that engine needs a complete overhaul, rather than possibly only an upper-end job, proceed as follows:

(If motorcycle is used with sidecar or package truck, remove it.)

1. Disconnect battery ground connection.
2. Remove instrument panel cover: 1946 and earlier Models require removal of speedometer lamp switch knob, front hexagon head screw, two side screws and cover side plate; 1947 Models require removing cap screw and cover side plate.
3. Disconnect shifter lever bottom bolt.
4. Drain gasoline from both tanks. Disconnect gasoline pipe from left tank and disconnect tank interconnecting pipe from right tank.
5. Remove gasoline tanks: This requires removal of the two front end bolts (upper and lower) and two stud nuts at rear between tanks directly behind saddle bar hinge bracket. (Saddle post clevis pin must be removed and saddle bar must be hinged forward.)
6. Remove cylinder head bracket: Pay particular attention to shim washers between cylinder head bracket and frame lug; these will have to be refitted when reinstalling engine. O.H.V. Engine—choke lever need not be removed from bracket—disengage choke rod from lever by turning bracket.
7. Remove spark plugs to avoid damaging. Use Harley-Davidson special wrench, Part No. 11929-40.
8. Disconnect throttle control wire at carburetor and remove carburetor control wire housing from front clamp.
9. O.H.V. Engine: Disconnect spark control wire at circuit breaker and free spark control wire housing from relay bracket.

*Side Valve Engine:* Disconnect spark control wire at circuit breaker and free spark control wire housing from front cylinder base stud.

10. Remove brake lever from brake cross-over shaft, and remove right footboard and brake pedal assembly.
11. Remove muffler and rear exhaust pipe, front exhaust pipe, and rear exhaust pipe connection. If motorcycle is used with sidecar, or package truck, lower front connection tie rod must be removed to free front exhaust pipe.
12. Drain oil tank or install nipple cap, Part No. 3583-15. Remove oil pump feed pipe, oil tank vent pipe, and oil return pipe.
13. Motorcycle equipped with relay only: 1946 and Earlier Models—disconnect wire from each of the two terminals at one end of relay. 1947 Models—disconnect wires from all relay terminals.
14. Disconnect oil pressure switch wire from pressure switch terminal.
15. Remove the two engine mounting bolts from right side. Front bolt nut stays in place beneath generator and does not require holding while removing or installing bolt.
16. Remove mesh type air cleaner, or air intake, and gasoline pipe. If equipped with oil bath air cleaner, refer to operation 10 under "Disassembling O.H.V. Engine," Page 37, or operation 12 under "Disassembling Side Valve Engine," Page 40.
17. Disconnect circuit breaker low tension wire from coil rear terminal—if wire is shielded, disconnect metallic shielding from coil rear lower terminal.
 

*Motorcycle equipped with relay only: 1946 and earlier Models—disconnect wire from generator terminal marked "switch." 1947 Models—disconnect wires from generator terminals marked "switch" and "relay."*

*Motorcycle equipped with current and voltage regulator: Disconnect wires from generator terminals marked "switch" and "relay," and remove generator end cover screw securing metallic shielding.*
18. Remove left footboard and studs.
19. Remove outer front chainguard.
20. Remove engine sprocket nut (right thread) using Harley-Davidson special wrench, Part No. 12645-26. It will be necessary to strike wrench handle with a hammer to loosen nut. Free sprocket from shaft taper by striking flat surface, near outer edge, a light but sharp rap with a hammer being careful not to strike sprocket teeth or sprocket shaft threads. Sprocket and chain are then free to be removed. Bend ears of screw lock away from head of each of the three cap screws which secure front end of inner chain guard to crankcase, and remove cap screws and lock.
21. O.H.V. Engine: Free speedometer cable housing from crankcase top center stud. *Side Valve En-*



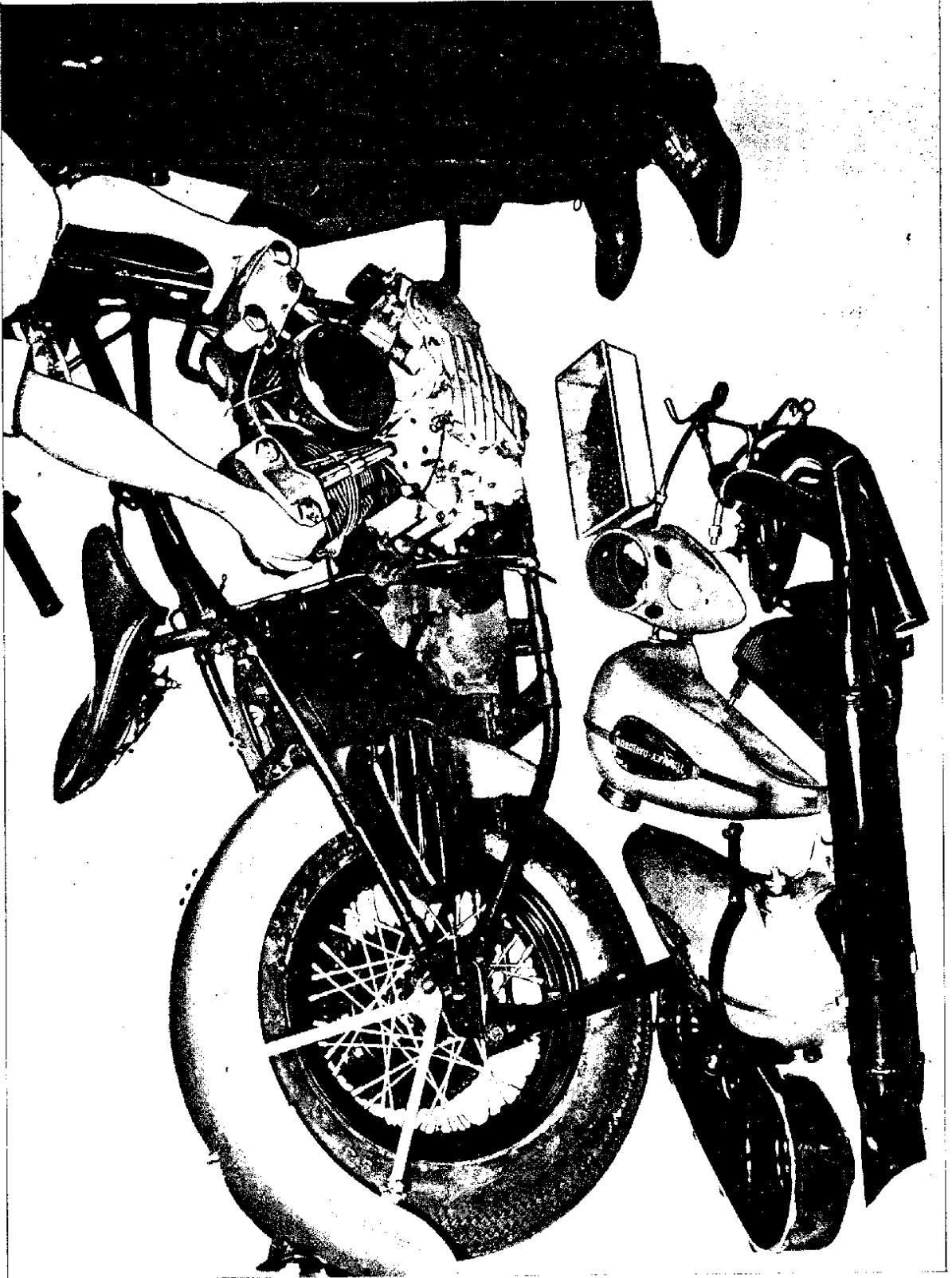

ILLUS. 31  
REMOVING ENGINE FROM CHASSIS

gine: Free speedometer cable housing from rear cylinder base stud.

22. Remove the two engine mounting bolts from left side.
23. Remove engine from right side of chassis.

## DISASSEMBLING ENGINE FOR COMPLETE OVERHAUL

### Disassembling O.H.V. Engine

(After Removing From Chassis Completely Assembled)

1. Remove upper-end parts as outlined under "Disassembling Engine for Top Overhaul Only" (O.H.V. Engine), Page 37.
2. Remove pistons. See "Piston and Pin," Page 88.
3. Remove generator as outlined under "Removing Generator," Page 97.
4. Remove circuit breaker assembly from crankcase: Free low tension wire from clip on crankcase—if wire is shielded, disconnect metallic shielding from crankcase stud. Remove relay and relay bracket. Remove two cap screws (9) (see Illus. 66) and then circuit breaker completely assembled can be lifted off. Be careful not to damage base gasket if new one is not available.
5. Remove gear case cover: Remove gear case cover screws and cover is then free to be removed. Cover is located on dowel pins which fit rather snugly and it must be worked off these pins carefully to avoid damage to cover and joint faces. Do not pry off with screwdriver inserted between joint faces. Use a hammer and a block of wood and tap lightly at the ends where the cover projects beyond the gear case.  
Unless a new gasket is available, be very careful not to damage or break the old one as this gasket is special as concerns thickness and hole for oil passage. It should be replaced with a "factory-made" gasket.
6. Remove timing gears: After removing lock rings and collars from gear studs, gears, breather valve and pinion shaft fittings, except gear shaft bearing oil seal ring can be removed. Gear shaft bearing oil seal ring cannot be removed until after removal of oil pump drive gear.
7. Remove oil pump: 1940 and earlier Model pump—remove the six nuts and washers that secure pump to crankcase. 1941 to 1947 Model pump—remove in order named, the five nuts, one cap screw and washers that secure pump to crankcase, pump cover, governor rotor, cover plate and the countersunk flat head screw that secures pump to crankcase.

Remove lock ring, and drive shaft gear and key from inner end (inside gear case) of pump drive shaft, and then pump with shaft assembled can be removed from crankcase.

Unless new gaskets are available, be very careful not to damage or break the old ones. These are special gaskets as concerns both thickness and

holes for oil passages. It is not advisable to attempt to replace them with "home-made" gaskets. Leaving out one hole or getting one in the wrong location is enough to put the entire oiling system out of commission. When new gaskets are needed, they should be replaced with "factory-made" gaskets.

8. Disassemble crankcases: Crankcases are held together with one cap screw, six studs with a nut on each end and one crankcase breather stud assembly. The cap screw enters through left case and threads into right case. Take out cap screw and remove nut from one end of each stud. Three of these studs, the one at top between cylinders and two at bottom are a tight fit and will have to be driven out with a drift of somewhat smaller diameter than studs. With all studs and screws removed, crankcases can be separated. If they don't come apart freely, tap at mounting lugs, using a block of wood and a hammer. Main bearing parts shown in Illus. 62 are now exposed.
9. Disassemble flywheels: Remove lock washer and nut from left end of crank pin. Tilt flywheel assembly on right flywheel and strike rim of left wheel with soft hammer about 90° away from pin. One or two sharp blows will usually loosen wheel. Do not strike wheel on its side, as doing so might either break flywheel or damage the tapered hole. With flywheels apart, connecting rods and roller bearing assembly can be removed from crank pin. Note that female (forked) rod is for the rear cylinder and male (single end) rod is for the front cylinder.

In connection with a complete overhaul, where all main bearings as well as connecting rod lower bearings are to be refitted, remove all shafts from flywheels. When crank pin is removed from right flywheel, it will be noted that this end of pin is a taper fit in flywheel, the same as the other end, but in addition is keyed. The purpose of this key is to locate the drilled oil passage in crank pin so that when wheels are assembled it will register exactly with drilled oil passage in right flywheel.

### Disassembling Side Valve Engine

(After Removing From Chassis Completely Assembled)

1. Remove upper end parts as outlined under "Disassembling Engine for Top Overhaul Only" (Side Valve Engine), Page 40.
2. Remove pistons. See "Piston and Pin," Page 88.
3. Remove generator as outlined under "Removing Generator," Page 97.
4. Remove oil feed pump: Oil pump is secured by one hexagon-head screw and three nuts. Two of the nuts are extra long to provide wrench clearance and their location should be noted so they will be put back where they belong. After removing screw and nuts, pump can be pulled off (see Illus. 21).

Unless a new gasket is available, be very careful not to damage or break the old one. This is a special gasket as concerns both thickness and holes for oil passages. It is not advisable to replace it with a "home-made" gasket. Leaving out a hole or getting one in the wrong location is enough to put the entire oiling system out of commission. When a new gasket is needed, it should be replaced with a "factory-made" gasket.

5. Remove circuit breaker assembly from timing gear case cover: See Illus. 68. If low tension wire is shielded, disconnect metallic shielding from oil feed pump stud. Remove circuit breaker cover and unlatch cover retainer ends from holes in circuit breaker head. Head and also head seating tension (ground) spring underneath base are now free and head can be lifted off, exposing two screws that secure base to gear case cover. After removing these screws and lock washers, base with shaft and drive gear can be lifted out of cover. Be careful not to damage base gasket if new one is not available.

6. Remove gear case cover: Take out all remaining timing gear case cover screws and cover is then free to be removed. Cover is located on dowel pins which fit rather snugly and it must be worked off these pins carefully to avoid damage to cover and joint faces. Do not pry off with screwdriver inserted between joint faces. Use a hammer and a block of wood and tap lightly at the ends where the cover projects beyond the gear case.

**CAUTION:** The thin steel shim washers assembled on outer ends of front cylinder cam gears may come off with the cover.

Sometimes one or more cam gears may come off with cover and if so, be careful that the thin steel shim washers on cam gear shafts are not lost, and also observe number and location of shims.

Unless a new gasket is available, be very careful not to damage or break the old one as this gasket, like the oil feed pump gasket is special as concerns both thickness and holes for oil passages. It should be replaced with a "factory-made" gasket.

7. Remove scavenger pump and crankcase breather valve: Scavenger pump is secured underneath gear case with four studs and nuts. Remove nuts and pump can then be pulled off the studs.

Breather valve is an integral part of scavenger pump. Screen between breather valve and crankcase port is free to come out when pump is removed.

8. Remove timing gears: After removing lock ring and washer from gear stud, gears and pinion shaft fittings can be removed (see Illus. 32). Be careful that the thin steel shim washers on cam gear shafts are not lost, and also observe number and location of shims.

9. Disassemble crankcases: Crankcases are held together with two cap screws, and five studs with a nut on each end. The two cap screws enter through the left case and thread into right

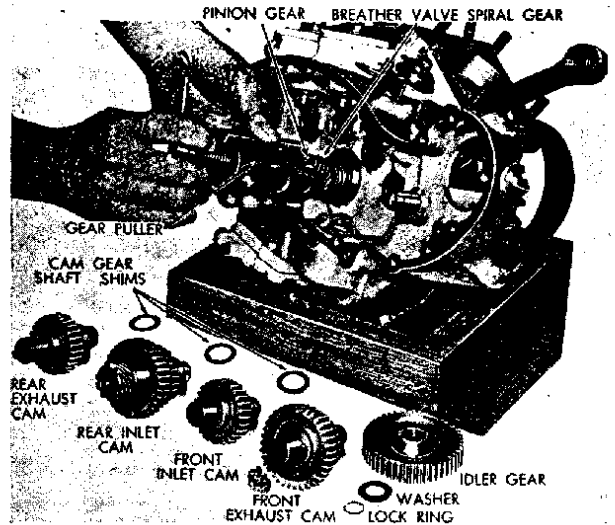

ILLUS. 32  
REMOVING TIMING GEARS (SIDE VALVE ENGINE)

case. Take out cap screws and remove nut from one end of each stud. Three of these studs, the one at top between cylinders and two at bottom, are a tight fit and will have to be driven out with a drift of somewhat smaller diameter than studs. With all studs and screws removed, crankcases can be separated. If they don't come apart freely, tap at mounting lugs, using a block of wood and a hammer. Main bearing parts shown in Illus. 63 are now exposed.

10. Disassemble flywheels: Remove lock washer and nut from left end of crank pin. Tilt flywheel assembly on right flywheel and strike rim of left wheel with soft hammer about 90° away from pin. One or two sharp blows will usually loosen wheel. Do not strike wheel on its side, as doing so might either break flywheel or damage the tapered hole. With flywheels apart, connecting rods and roller bearing assembly can be removed from crank pin. Note that female (forked) rod is for the rear cylinder and male (single end) rod is for the front cylinder.

In connection with a complete overhaul, where all main bearings as well as connecting rod lower bearings are to be refitted, remove all shafts from flywheels. When crank pin is removed from right flywheel, it will be noted that this end of pin is a taper fit in flywheel, the same as the other end, but in addition is keyed. The purpose of this key is to locate the drilled oil passage in crank pin so that when wheels are assembled it will register exactly with drilled oil passage in right flywheel.

## FITTING AND REASSEMBLING ENGINE

### Cleaning and Inspecting Parts

First thoroughly wash all parts in gasoline or solvent and inspect them for wear and damage. Clean out oil passages in pinion shaft, right flywheel and timing gear case cover, with a piece of wire, and compressed air. Clean dry shellac from crankcase center joint and register, with a scraper. Do this carefully to avoid any deep scratches that may allow oil leakage when cases are reassembled.

Clean outside of cylinder and head with wire brush to remove dirt, rust, etc., getting in between cooling fins as much as possible. Scrape carbon from cylinder head, top of cylinder, top of bore above ring path, and inlet and exhaust valve ports. When scraping carbon, be careful not to deeply scratch or nick cylinder and head joint faces, as a deep scratch may result in a leak. Blow off loosened carbon, dirt, rust, etc., with compressed air and wipe cylinder bore and joint faces with a clean rag. O.H.V. Engine: Clean out valve spring covers and their oil return lines.

All Models: Check pinion gear for fit on pinion shaft. Gear should be from snug fit to free sliding fit on pinion shaft but should have no perceptible lash. Even slight lash will usually result in noisy operation for which other timing gears are often held responsible. To correct such a condition will require renewing pinion gear and/or pinion shaft.

Carefully remove carbon from pistons. If a tool for cleaning ring grooves is not available, sharpen end of a broken ring to a chisel edge. Avoid scratching or damaging sides of ring grooves.

Carefully examine all shafts and bearing races for damaged and pitted surfaces and measure shafts with micrometer for extent of wear. If any parts are found with rough or pitted surfaces, renew them. Also renew races that are found worn .0005" or more. Renew any shafts that show any trace of wear shoulder at sides of roller paths or are worn .0005" or more.

Examine roller retainers for cracks and extent of wear; compare with new retainer. If retainer backs are worn thin or retainers are worn to any noticeable extent otherwise, renew them.

### Refinishing Cylinders Oversize and Fitting New Pistons

In reconditioning an engine, cylinders and pistons must be accurately measured with micrometers for extent of wear. Inside and outside micrometers used for cylinder-piston fitting should first be checked together to be sure they are adjusted to read exactly the same. By subtracting piston measurement from bore measurement, amount of piston-cylinder clearance is obtained.

Bore measurement of a used and worn cylinder should be taken  $\frac{1}{2}$ " from top of cylinder, in ring path, measuring front to rear, where thrust faces of piston bear (see Illus. 33).

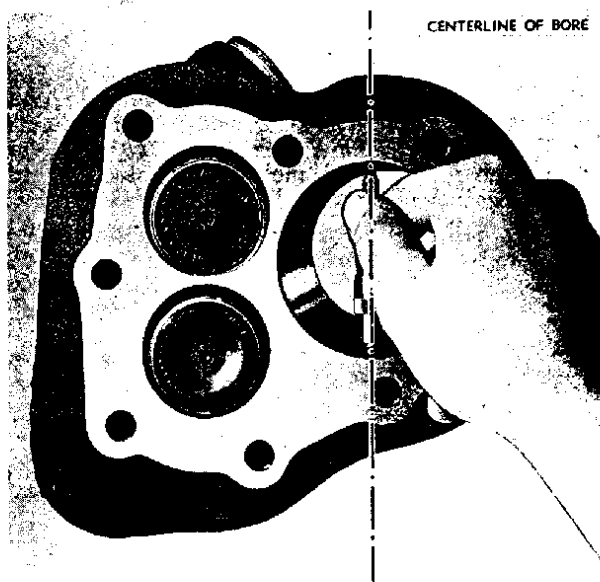

ILLUS. 33  
MEASURING CYLINDER

Piston measurement should be taken at extreme bottom of skirt, measured front to rear,  $90^\circ$  from center line of piston pin (see Illus. 34).

In connection with only a top overhaul, if cylinders are not scored and are worn less than .002", it is not usual practice to refinish oversize at that time; this operation is left to be done in connection with next complete overhaul. However, in this case, if the total piston clearance is as much as .006", new

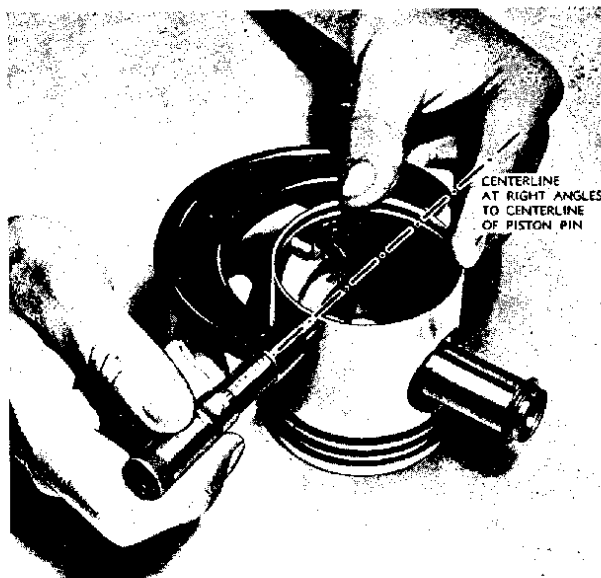

ILLUS. 34  
MEASURING PISTON



standard piston or piston of the same oversize to which the cylinder was last refinished should be fitted to reduce clearance and effect reasonably quiet operation.

See "Emergency Piston and Ring Service," Page 87. If, in completely overhauling engine and putting it in like-new condition for a long period of further service, cylinders show more than .002" wear, they should be refinished to the next oversize step and fitted with new pistons.

When refinishing cylinders oversize, first add to standard cylinder bore size the oversize step apparently required to clean up bore; this gives the exact sizes to which cylinder should be refinished; example: 3.3125" (standard bore) plus .020" (oversize) equals 3.3325" (size to which cylinder should be refinished.) Check carefully with accurate micrometers to be sure of refinishing to this size. If this is accurately done, oversize pistons furnished in various oversize steps will fit with normal clearance.

Pistons are regularly supplied in the following oversizes: .005", .010", .020", .030", .040", .050", .060" and .070". Oversize pistons have their oversize stamped on head; for example: 10, 20, etc.

Cylinders can be refinished oversize either with a hone only, or with a boring bar followed by a finishing hone. In general practice only cylinders not scored and not badly worn are refinished entirely with a hone. Cylinders badly worn or deeply scored are first rebored to nearly the required oversize and then are finish-honed to exact size. When cylinders must be rebored to beyond .070" oversize to clean up, their oversize limit has been exceeded and the cylinders must be replaced with new ones.

### Valve Guides (O.H.V. Engine)

Clean valve guides with Harley-Davidson special reamer, Part No. 11894-47, and check for wear and valve stem clearance. Standard valve stem-valve guide clearance is .004" to .006". Clearance should not be allowed to exceed .008" before renewing guide or, possibly, both valve and guide.

Valve guides are a press fit in cylinder heads. Therefore, when necessary to remove, press or drive them out of heads. Be careful not to damage valve spring covers when removing and replacing valve guides. Spring covers are held in place by valve guides, and when guides are removed, covers are free. Intake and exhaust valve guides are not interchangeable—top of intake valve guide is beveled; top of exhaust valve guide is flat.

New valve guides are reamed to correct size. However, when guides are pressed into cylinder heads, they may close up slightly; also the ends may be burred. Therefore, after new guides are in place, they should be sized and cleaned up with Harley-Davidson special reamer, Part No. 11894-47.

It is of prime importance that valve guides fit tightly in cylinder heads. If they don't, valves may not seat properly, spring covers will be loose and oil leakage between spring covers and cylinder heads will result. If original guide or new standard guide is not a tight press fit, an oversize guide must

be installed. Oversize guides can be obtained .001" and .002" oversize.

After installing valve guides, valve seats must be refaced to true them with guides. See "Valve Seats," Page 47, and "Reassembling Cylinder Heads (O.H.V. Engine)," Page 52.

### Valve Guides (Side Valve Engine)

Clean valve guides with Harley-Davidson special reamer, Part No. 11894-30, and check for wear and valve stem clearance. Standard valve stem-valve guide clearance is .003" to .005". Clearance should not be allowed to exceed .008" before renewing guide or, possibly, both valve and guide.

Valve guides are a press fit in cylinders. Therefore, when necessary to remove, press or drive them out of cylinders (see Illus. 36). Intake and exhaust valve guides are interchangeable.

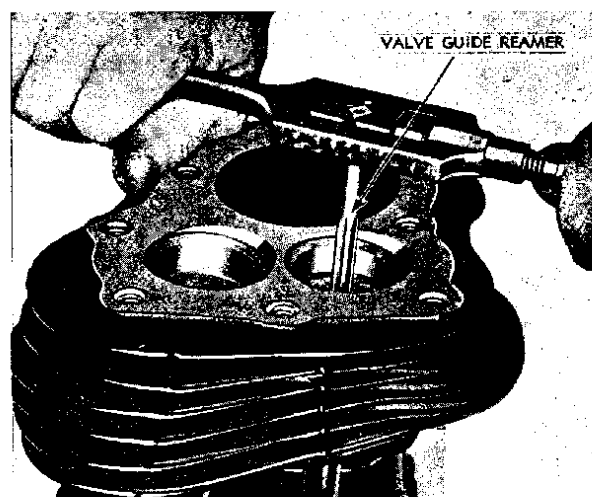

ILLUS. 35  
REAMING VALVE GUIDES

Install new valve guides by inverting cylinder and pressing or driving guides into guide holes until shoulder on guide is tight against cylinder. New valve guides are reamed to correct size. However, when guides are pressed into cylinders they may close up slightly; also the ends may be burred. Therefore, after new guides are in place, they should be sized and cleaned up with Harley-Davidson special reamer, Part No. 11894-30. See Illus. 35.

It is of prime importance that valve guides fit tightly in cylinders. If they don't, valves may not seat properly. If original guide or new standard guide is not a tight press fit, an oversize guide must be installed. Oversize guides can be obtained .001" and .002" oversize.

After installing valve guides, valve seats must be refaced to true them with the guides. See "Valve Seats," Page 47.

### Valves

Before refacing valves, remove carbon from valve head and stem, using a knife and wire wheel—never



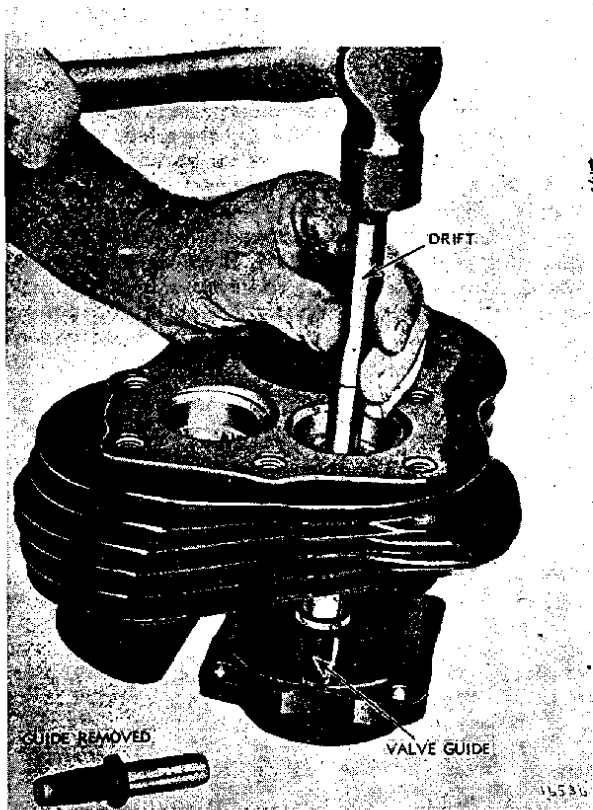

ILLUS. 36  
REMOVING VALVE GUIDES

a file or other hardened tool that will scratch or nick valve. Polish valve stem with very fine emery cloth or steel wool. Check the valve stem for excessive wear; standard valve stem diameter is:

*O.H.V. Engine:* .374" to .375"; *Side Valve Engine:* .370" to .371". If valve is warped, this will be indicated when face is reground.

*All Models:* Valve face angle is 45° for both intake and exhaust valves, and valve refacing grinder must be adjusted exactly to this angle. It is important not to remove any more metal than is necessary to clean up and true valve face. If grinding leaves the edge of valve very thin or sharp, install a new valve. A valve in this condition does not seat normally, will burn easily and may cause pre-ignition. There is also danger of cracking.

If end of valve stem shows uneven wear, true end of stem on a valve refacing grinder equipped with suitable attachment.

Intake and exhaust valves are made of different materials and must not be interchanged. Intake valves are marked "IN" on head; exhaust valves are marked "EX."

### Valve Seats

Valve seats, like valves, are subject to wear, pitting and burning and should be refaced each time valves are refaced. Be careful that no more metal is

removed than absolutely necessary to completely clean up and true valve seats.

*O.H.V. Engine:* Has valve seat inserts so hard that a seat cutter will not work—they must be refaced with grinder. Inserts should be checked for leakage and looseness in cylinder heads, and any found defective must be replaced. A leaky insert may cause overheating to the extent that piston may be seriously damaged.

*Side Valve Engine:* Seats can be refaced with either cutter or grinder, however, a seat refaced with cutter will not be as smooth as when refaced with grinder and a greater amount of lapping will be necessary to attain a perfect seat.

As valves and seats are refaced from time to time, valve seats widen and valves seat in lower position when fully closed. Also, passage around valve when fully open would be somewhat restricted. *O.H.V. Engine:* To correct this condition, will require replacing valve seat insert. *Side Valve Engine:* To correct this condition, additional clearance will need to be cut above seat so top edges of angular valve face and seat match exactly. Use Harley-Davidson special clearance cutter, Part No. 11890-47 (see Illus. 37 and Illus. 61).

When a valve guide is removed for any reason and replaced or a new guide installed, it is not likely to be concentric with valve seat. If a valve guide is not concentric or true with seat, leakage and burning of valve may result, or valve may break due to cocked seating and deflection of valve stem. Therefore it is especially important after installing new guides that seats be carefully refaced to make them concentric with guides and assure perfect alignment and matching of valve face and valve seat. See "Valve Guides (O.H.V. Engine)," or "Valve Guides (Side Valve Engine)," Page 46.

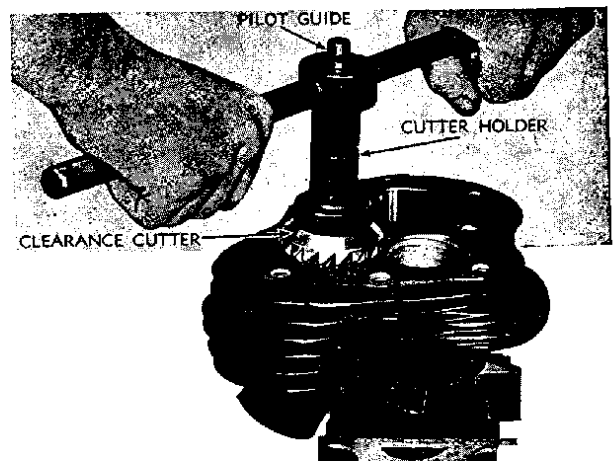

ILLUS. 37  
USING VALVE SEAT CLEARANCE CUTTER  
(SIDE VALVE ENGINE)

### Grinding and Testing Valves and Valve Seats

If valve seats and valve faces have been smoothly and accurately refaced with grinders available



Memoranda

Speling zuigera 0,08 mm

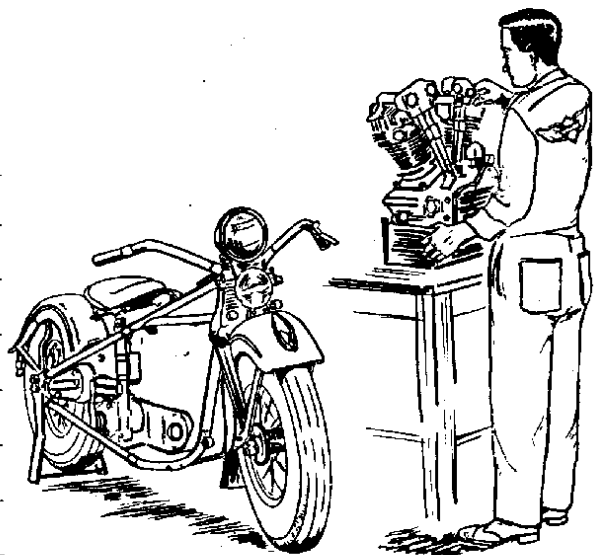

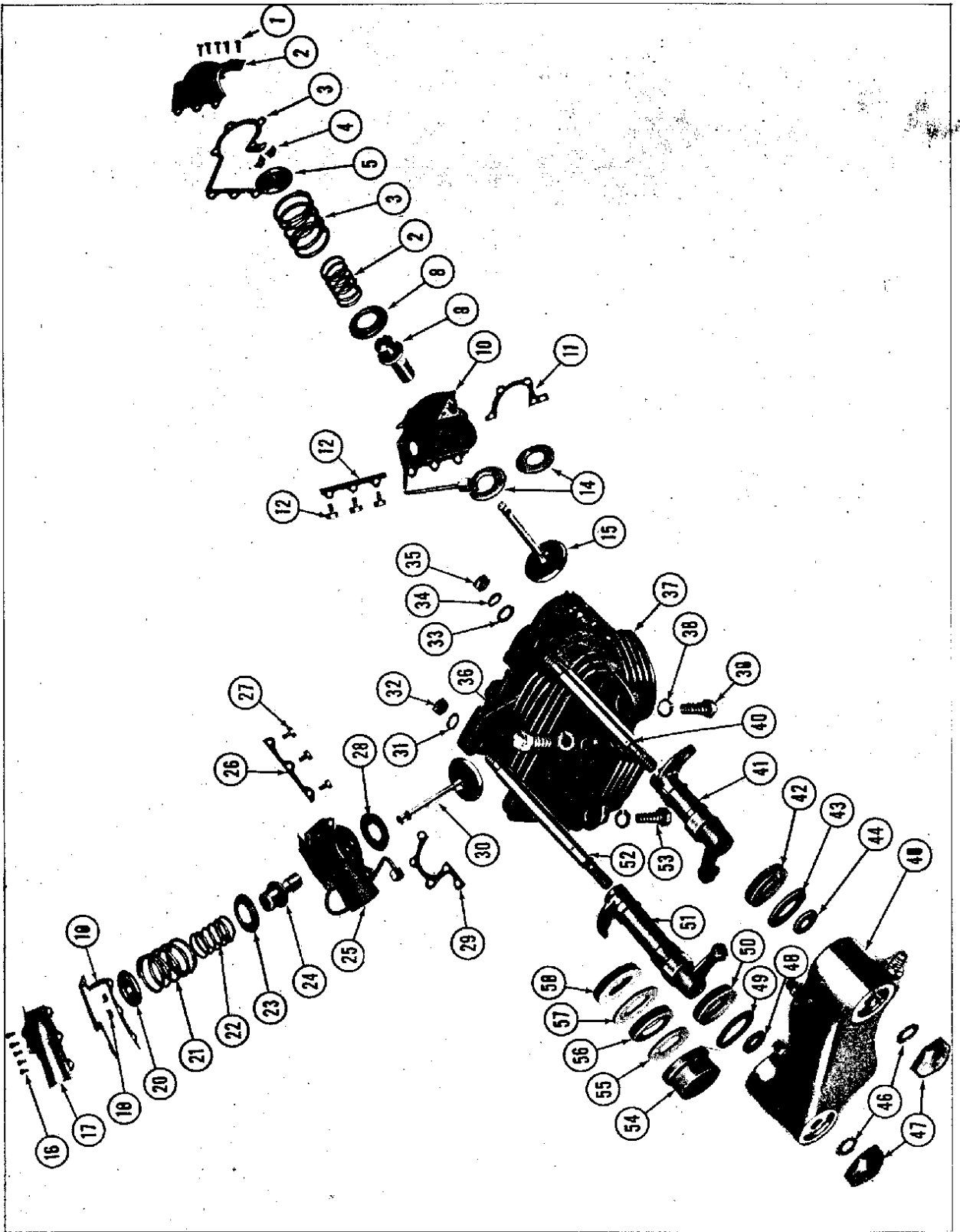

ILLUS. 39  
 REAR CYLINDER HEAD DISASSEMBLED (O.H.V. ENGINE)

## REAR CYLINDER HEAD ASSEMBLY (O.H.V. ENGINE)

(To Identify Items, Refer to Illus. 39)

ITEM	NUMBER USED	PART NUMBER	NAME
1	16	179-39	Rocker Arm Cover Screw (same as Items 13, 16 and 27)
2	1	174-38A	Intake Cover Plate
3	1	175-38A	Intake Cover Gasket
4	2	172-36	Valve Key (Pair)—(same as Item 18)
5	2	170-36	Upper Valve Spring Collar (same as Item 20)
6	2	168-36	Outer Valve Spring (same as Item 21) Free length $1\frac{13}{16}$ "—110 to 120 pounds @ $1\frac{1}{16}$ "
7	2	169-36	Inner Valve Spring (same as Item 22) Free length $1\frac{13}{32}$ "—70 to 80 pounds @ $\frac{29}{32}$ "
8	2	171-36A	Lower Valve Spring Collar (same as Item 23)
9	1	167-40	Intake Valve Guide (top end of guide is beveled—oversizes available .001" and .002")
10	1	173-38A	Intake Valve Spring Cover
11	1	176-38B	Intake Spring Cover Screw Plate (curved)
12	1	176-38C	Intake Spring Cover Screw Plate (straight)
13	See Item 1		
14	3	176-37	Spring Cover Asbestos Gasket (same as Item 28—two under intake valve spring cover— <u>one</u> under exhaust valve spring cover)
15	1	163-36	Intake Valve (.004" to .006" clearance in valve guide—marked "IN" on head)
16	See Item 1		
17	1	174-38	Exhaust Cover Plate
18	See Item 4		
19	1	175-38	Exhaust Cover Gasket
20	See Item 5		
21	See Item 6		
22	See Item 7		
23	See Item 8		
24	1	167-36	Exhaust Valve Guide (top end of guide is flat—oversizes available .001" and .002")
25	1	173-38C	Exhaust Valve Spring Cover
26	1	176-38A	Exhaust Spring Cover Screw Plate (straight)
27	See Item 1		
28	See Item 14		
29	1	176-38	Exhaust Spring Cover Screw Plate (curved)
30	1	165-36	Exhaust Valve (.004" to .006" clearance in valve guide—marked "EX" on head)
31	2	0265	Lock Washer (same as Item 34)
32	2	0136	Rocker Arm Shaft Nut (same as Item 35)
33	1	0229	Plain Washer
34	See Item 31		
35	See Item 32		
36	1	071	Rocker Arm Housing Cap Screw (upper)
37	1	10-40	Cylinder Head
38	3	0261	Rocker Arm Housing Cap Screw Lock Washer
39	2	073	Rocker Arm Housing Cap Screw (lower)—(same as Item 53)
40	1	106-39	Intake Rocker Arm Shaft
41	1	99-39	Intake Rocker Arm (.007" to .016" sideplay)
42	2	120-38	Oil Seal (same as Item 50)
43	2	123-36	Oil Seal Retaining Washer (same as Item 49)
44	2	119-36	Rocker Arm Thrust Washer (same as Item 48)
45	1	91-41	Aluminum Rocker Arm Housing
46	2	469-15	Plain Washer
47	2	114-36	Rocker Arm Shaft Nut
48	See Item 44		
49	See Item 43		
50	See Item 42		
51	1	101-39	Exhaust Rocker Arm (.007" to .016" sideplay)
52	1	108-39	Exhaust Rocker Arm Shaft
53	See Item 39		
54	1	177-38	Exhaust Spring Cover Adaptor
55	1	178-38	Oil Seal Retaining Washer
56	1	120-38A	Oil Seal
57	1	123-36	Oil Seal Retaining Washer
58	1	120-38B	Oil Seal
			1940 and earlier models: Use Items 42 and 43 for intake rocker arm; Items 54, 55, 56, 57 and 58 for exhaust rocker arm.
			1941 and later models: Use Items 42, 43, 49 and 50.



## Reassembling Cylinder Heads (O.H.V. Engine)

(To Identify Items, Refer to Illus. 39)

Note: While Item numbers shown and identified, refer to Rear Cylinder Head Assembly, corresponding parts (except Items 54, 55, 56, 57 and 58) are included in Front Cylinder Head Assembly.

Valve spring covers (10) and (25) are secured in place by valve guides (9) and (24). When renewing guides, also renew spring cover asbestos gaskets (14) and (28) between cylinder heads and spring covers.

Scrape clean, the cylinder heads and bottoms of spring covers of any oil seal material that may have adhered when covers were taken off.

Sort out valve spring covers, screw plates and cover plates. Covers are in three lengths—longest one for front exhaust; shortest one for rear intake; other two covers are of same length and are identified by length of oil return pipes—cover with longer pipe is for rear exhaust. The spring cover screw plates which partially encircle covers, must be assembled on covers before covers are installed on cylinder heads.

Place one spring cover asbestos gasket (28) between each exhaust valve spring cover and cylinder head and two between each intake valve spring cover and cylinder head. Press in valve guides (the top of intake valve guide is beveled—exhaust valve guide is flat) as close as possible to a tight seat and still be able to shift covers slightly. It is advisable to renew spring cover asbestos gaskets when valve guides are installed.

Install rocker arm shafts only to bare aluminum rocker arm housing and install housings and shafts temporarily to cylinder heads to line up spring covers. Rocker arm shaft holes in covers will, of course, have to register exactly with holes in cylinder head rocker arm shaft brackets before shaft ends will pass through. Open ends of covers must be lined up as well as possible with holes in aluminum housings. They will not in every case center in holes but must not bear against aluminum housings. Occasionally it may be necessary to spring the covers slightly to make them line up. After they have been lined up, finish pressing in valve guides (all the way down) to secure spring covers. If covers are not firmly secured, oil leakage will result. After covers are adjusted and guides tight, remove aluminum housings and rocker arm shafts. See "Valve Guides (O.H.V. Engine)," Page 46.

If tubular cover spacer (54) (1940 and earlier Models) is removed from rear aluminum rocker arm housing for any reason, apply a thin coating of gasket cement or sealer to outside where it enters hole, before installing, to prevent oil leakage. Make sure spacer bottoms in housing.

1941 and later Models have rear aluminum rocker arm housing boss extended which eliminates tubular cover spacer used on earlier Models.

Before assembling rocker arms into aluminum housings, inspect rocker pads and ball studs. Worn rocker pads, if not too badly worn, can be dressed

on a grinder, maintaining original pad curve. Worn and flattened ball studs must be replaced, otherwise satisfactory tappet and push rod adjustment cannot be made and upper end push rod trouble is likely to be experienced.

Oil seals and oil seal retaining washers must be assembled on rocker arms before arms are installed in housings.

*1940 and earlier Models:* One of the larger oil seals has no fabric on either side and is to be installed on rear exhaust rocker arm, either side of seal facing ball stud end. The three remaining larger oil seals are to be installed on rocker arms with fabric side of seal facing ball stud end. This method of installing oil seals supersedes the earlier method of installing them with fabric side of seal against end of spring cover. The smaller oil seal is to be installed on rear exhaust rocker arm with cupped side of seal facing ball stud end.

Install on rear exhaust rocker arm (ball stud end) in order named—larger oil seal (58) (no fabric), larger oil seal retaining washer (57), smaller oil seal (56) and smaller oil seal retaining washer (55). The three remaining larger oil seals and seal retaining washers are to be installed on rocker arms in same order as larger oil seal and retaining washer are installed on rear exhaust rocker arm.

*1941 to 1947 Models:* The four oil seals are alike and are to be installed on rocker arms with fabric side of seal facing ball stud end. This method of installing oil seals supersedes the earlier method of installing them with fabric side of seal against end of spring cover.

Install on each rocker arm (ball stud end) in order named—oil seal (42) and oil seal retaining washer (43).

*All O.H.V. Models:* Rocker arm thrust washers (44) and (48) must be located, one in each counter-bore in aluminum housings before installing rocker arms and shafts. The shoulder or stepped side of washer must face rocker arm. If washers are not in place, spacing between aluminum housings and rocker arm shaft brackets will not be right and one or more brackets will probably be snapped off, when shaft nuts are tightened.

After rocker arms, oil seals and rocker arm shafts have been assembled in housings, apply a thin coat of gasket cement or sealer on under side of aluminum housings where they rest on cylinder heads and also on outer face of oil seals where they come in contact with ends of spring covers. This will insure against possibility of oil leakage around oil passage plugs and ends of spring covers.

Attach aluminum housings with assembled rocker arms to cylinder heads. Drive rocker arm shafts very carefully into shaft brackets. Do not force them as it does not take a very heavy blow with a hammer to break a bracket. If shafts are drifted evenly into brackets to avoid "cocking" the assembly, they will go in easily.

Install spacers or plain washers temporarily (in place of cylinder head bracket) on left end of each intake rocker arm shaft next to shaft bracket to take up space. The total thickness of the spacers or plain

washers for each intake rocker arm shaft must be from 9/32" to 5/16" to equal thickness of cylinder head bracket and washers that are to be installed later.

Install the plain washers (46), one on right end of each rocker arm shaft next to aluminum housings, and a lock washer (31) on left end of each exhaust rocker arm shaft next to shaft bracket. Install all shaft nuts and tighten them evenly and securely to imbed ends of spring covers in oil seals.

Now that all shaft nuts are securely tightened, and width of the assembly determined, see that holes line up so that cap screws securing housing to cylinder head can be installed without any binding. The longer screws (39) and (53) and lock washers are to be installed from under side and shorter screw (36) and lock washer are to be installed from top. If screws will not enter freely then something is wrong and they should not be forced into place. In this case inspection should be made to see that rocker arm thrust washers are in place. If everything seems to be in order but holes are slightly misaligned, they can be elongated with a round file to permit entering screws.

Following this procedure in securing aluminum housings is also of prime importance because if spacing and alignment are not correct and screws and nuts are pulled up tight, rocker arm brackets will be under stress and breakage will probably result.

After head assemblies are tightened up, and before cover plates are installed, note that rocker arms are not pinched endways. This is not likely to be found the case, especially when using old rocker arms, but it is possible.

If it is found there is binding endways, rocker arm will have to be shortened by grinding off either end slightly. Rocker arm should have .007" to .016" sideplay to allow for possibility of assembly closing up a little as rocker arm shaft nuts are loosened and tightened later on.

Determining whether or not there is end play and how much, is not so easy with an assembly just put up with new oil seals, as new seals pinch rocker arms and make them work hard as though they were a tight fit on shaft or were tight endways. This will have to be considered when determining end clearance.

Install valves. See "Installing Valve Assemblies," Page 48.

If cover plate gaskets are in good condition they can be reused, however, it is advisable to renew them. Apply a thin coat of gasket cement or sealer on underside of cover plate gaskets (3) and (19) and after allowing a few minutes for cement or sealer to air dry, install them on covers so holes line up. Now apply a thin coat of cement or sealer to top side of cover plate gaskets.

Now that assembly has been completed and rocker arm endplay checked to make sure there is no binding, install cover plates (2) and (17).

One method of installing cover plates is to use two tapered rods and insert them through screw

holes to align plates so screws can be entered straight and not become cross threaded.

An easier method is to again loosen rocker arm and housing assemblies, that is, remove cap screws that secure aluminum housings, and also remove nuts on left ends of rocker arm shafts and drift the assembly away from ends of spring covers about 1/8". Install cover plates and tighten screws securely, then drift assembly back in place and replace and tighten shaft nuts, and cap screws in aluminum housings, as explained in a previous paragraph.

After cylinder heads have been completely assembled, remove the spacers or plain washers from right end of each intake rocker arm shaft. Cylinder head bracket cannot be installed until after engine is in chassis.

### Cam Gear Shaft and Pinion Gear Shaft Bushings (O.H.V. Engine)

Check cam gear shaft bushing in right side crankcase, and cam gear shaft bushing and pinion gear shaft bushing in gear case cover for extent of wear. These bushings normally do not require renewal until an engine has run extremely high mileage. However, if engine has been run under dusty conditions without an air cleaner, or without giving proper attention to air cleaner if engine is so equipped, and considerable road dust has been taken into engine through carburetor, abnormal wear may be found at any mileage.

Specified clearance for cam gear shaft in cover bushing and crankcase bushing is .001" to .0015", and for pinion gear shaft in cover bushing is .0005" to .001". When bushings are worn to the extent of increasing clearance to .0025" or more, they should be renewed, as the cam gear is likely to become noisy with excessive clearance in these bushings. Worn bushing in case can be pushed out with an arbor press, supporting case on a suitable collar or sleeve at flanged end of bushing. Bushings in cover, must be pulled with Harley-Davidson special puller, Part No. 11952-36 (see Illus. 42, applying to Side Valve Engine).

Before removing old bushings, note location of oil transfer hole in pinion gear shaft bushing in timing gear case cover. New bushing must be installed with oil transfer hole in same location (transfer hole to line up with drilled oil passage in cover) as normal function of oiling system depends upon correct location of this hole. The cam gear shaft bushing in crankcase must be installed with oil slot in flange end of bushing upward.

Before pressing in new bushings note location of original dowel pin holes in crankcase and/or gear case cover for reference when drilling new dowel pin holes. When drilling dowel pin holes in crankcase and/or gear case cover, be sure to locate holes 1/8" or more from original dowel pin holes.

When pressing in bushings be sure bushing flanges are seated tight against crankcase and/or gear case cover.

After new bushings have been pressed in they must be dowel pinned to prevent them from turning.

by drilling a hole with a number 31 drill, 9/32" deep, through bushing flange and into aluminum so when dowel pin (Part No. 661-31) is driven in and bottomed, its end will be slightly below face of bushing flange. Peen bushing around dowel pin hole to prevent pin from coming out.

Oil hole for lubrication of cam shaft bushing in cover, will have to be drilled, with a 5/32" drill, using oil hole already in bushing boss as a drill guide.

After bushings have been pressed in, dowel pinned and necessary oil hole drilled, they must be line reamed with Harley-Davidson special reamers, Part Nos. 12134-36 and 12132-36. Cover must be installed and secured by at least four screws when line reaming bushings.

*Line reaming pinion gear shaft bushing:* Insert steel pilot bushing into crankcase roller race—insert Harley-Davidson special reamer, Part No. 12132-36, through pilot bushing, into pinion gear shaft bushing, and turn reamer until it bottoms in gear case cover. See Illus. 46.

*Line reaming cam gear shaft bushings:* Insert Harley-Davidson special reamer, Part No. 12134-36, through crankcase bushing, into cover bushing, and turn reamer until it bottoms in gear case cover. (See Illus. 44, applying to Side Valve Engine).

### Servicing Flutter Valve (Side Valve Engine)

(To Identify Items, Refer to Illus. 4 and 59)

Flutter valve (5) in gear case cover allows retrieving (by vacuum) any oil trapped in outside breather oil trap (10).

It is a disc type valve and has only a few thousandths movement. In order for this valve to function properly, it must be free working. A sticking valve will probably result in outside breather oil trap filling with oil to the extent that some oil will be blown out through outside breather tube (11), causing a messy condition around engine.

With flutter valve installed in cover, it can be checked as to its proper functioning by sucking and blowing through valve opening. If valve is functioning, it will open (admit air) when sucking, and close (shut off air) when blowing. It is, however, recommended that a new flutter valve be installed at each engine overhaul, regardless of its condition.

To install new flutter valve, first remove outside breather tube (11), then drive out valve with suitable punch inserted in hole that terminates in outside breather oil trap (10). Drive in new valve using a punch slightly smaller than outside diameter of valve housing. Do not, under any circumstances, use a punch inserted in valve opening as doing so will damage valve. After valve has been driven in and seated, stake it in place by upsetting aluminum at four equidistant points at edge of hole, with a small punch.

### Cam Gear Shaft and Pinion Gear Shaft Bushings (Side Valve Engine)

Check cam gear shaft bushings in right side crankcase and cam gear shaft and pinion gear shaft bushings in gear case cover for extent of wear. These bushings normally do not require renewal until an engine has run extremely high mileage. However, if engine has been run under dusty conditions without an air cleaner, or without giving proper attention to air cleaner if engine is so equipped, and con-

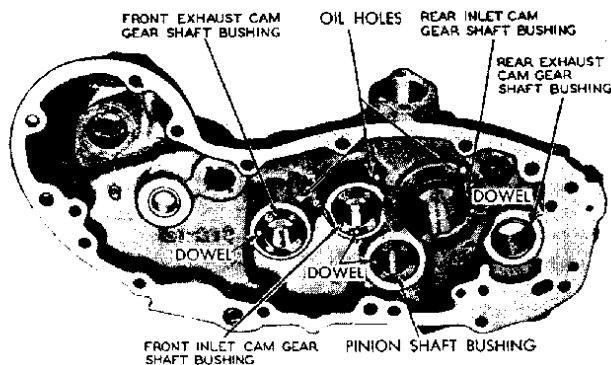

ILLUS. 40  
CAM GEAR SHAFT BUSHINGS IN GEAR CASE  
COVER (SIDE VALVE ENGINE)

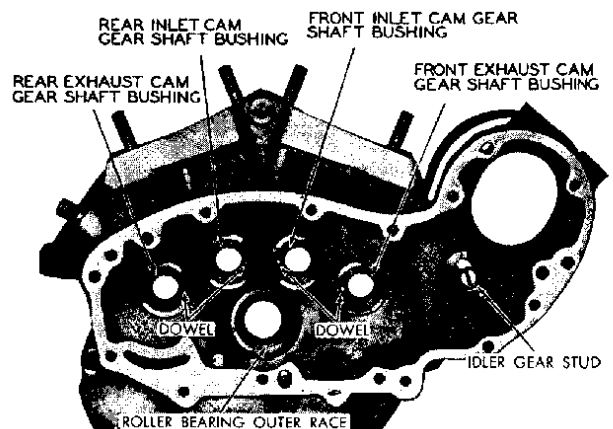

ILLUS. 41  
CAM GEAR SHAFT BUSHINGS IN RIGHT CRANKCASE  
(SIDE VALVE ENGINE)

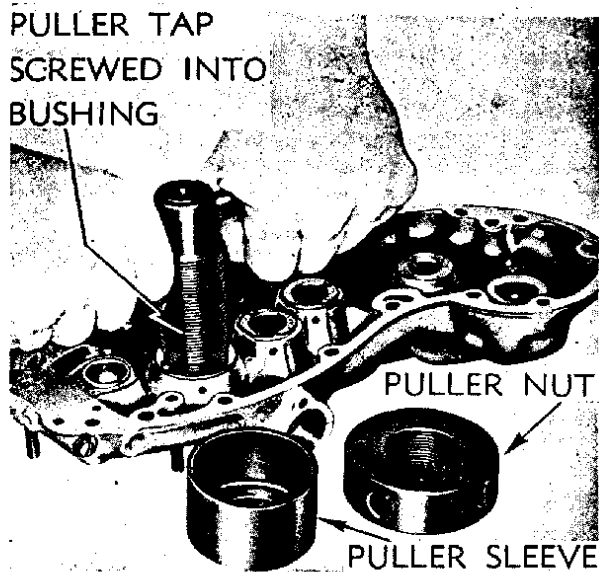

**A—THREADING TAP INTO BUSHING**

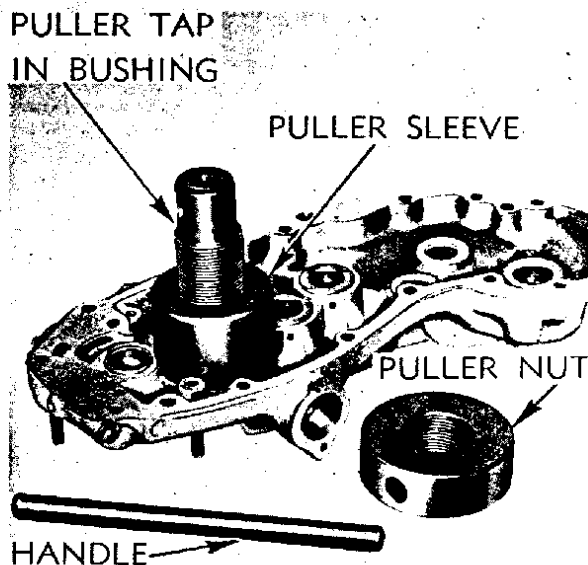

**B—PULLER SLEEVE LOCATED ON TAP**

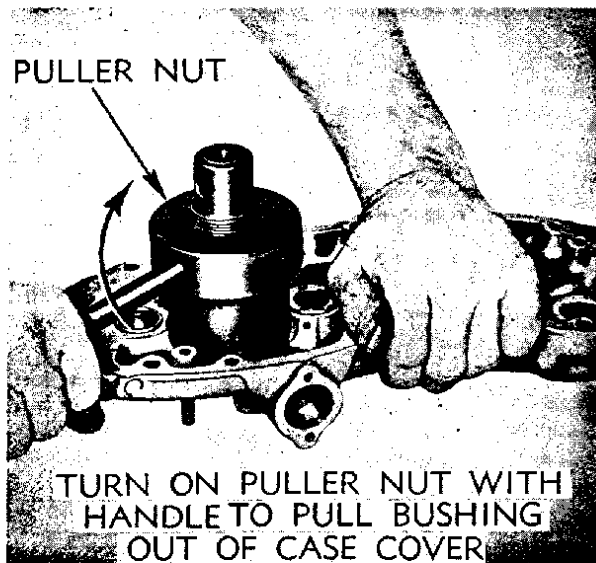

**C—TURN UNIT CLOCKWISE TO PULL BUSHING**

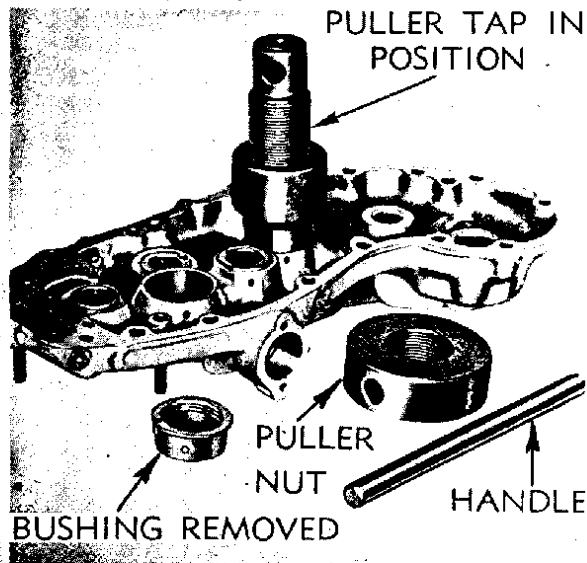

**D—USE STEPPED SLEEVE TO CLEAR BUSHING BOSS**

ILLUS. 42  
REMOVING BLIND BUSHINGS FROM GEAR CASE COVER (SIDE VALVE ENGINE)



siderable road dust has been taken into engine through carburetor, abnormal wear may be found at any mileage.

Specified clearance for cam gear shafts in cover bushings and crankcase bushings and for pinion gear shaft in cover bushing is .0005" to .001". When bushings are worn to the extent of increasing clearance to .002" or more, they should be renewed, as the cam gears are likely to become very noisy with excessive clearance in these bushings. Worn bushings in case and cover with both ends open, can be pushed out with an arbor press, supporting case or cover on a suitable collar or sleeve at the flanged end of bushing. Bushings in cover, with one end blind, must be pulled with Harley-Davidson special puller, Part No. 11952-36 (see Illus. 42).

Before removing old bushings, note location of oil transfer hole in pinion gear shaft bushing in timing gear case cover and location of oil grooves in the four cam gear shaft bushings in crankcase. New pinion gear shaft bushing must be installed with oil transfer hole in same location (30° ahead of vertical

center line) as normal function of oiling system depends upon correct location of this hole. The four cam gear shaft bushings in crankcase must be installed with oil groove in face of bushing flange upward (see Illus. 41).

Before pressing in new bushings, note location of original dowel pin holes in crankcase and/or gear case cover for reference when drilling new dowel pin holes. When drilling dowel pin holes in crankcase and/or gear case cover, be sure to locate holes 1/8" or more from original dowel pin holes.

When pressing in bushings (except rear exhaust cam gear shaft bushing in cover) be sure bushing flanges are seated tight against crankcase and/or gear case cover.

Before installing rear exhaust cam gear shaft bushing in cover, check thickness of bushing flange with micrometer. If bushing has a flange 1/8" thick, place it on a lathe mandrel and remove .015" from inner face of bushing flange and 1/32" from outer face of flange to make flange .078" to .079" thick. Later bushings are made to this specification, and

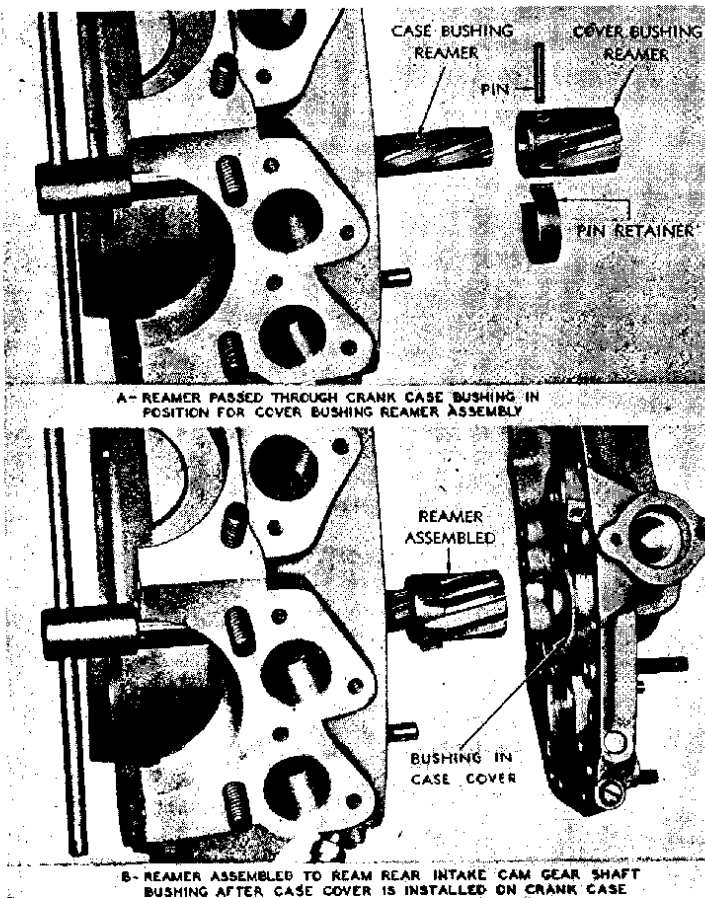

ILLUS. 43  
LINE REAMING REAR INTAKE CAM GEAR  
SHAFT BUSHINGS (SIDE VALVE ENGINE)

Note: Parts order bushings are furnished nearly to size so there is but little stock to be removed when reaming bushings. When line reaming two bushings, push reamer straight through first bushing until reamer just enters second bushing, then start reaming bushings. When removing reamer, keep turning it to the right as it is being pulled out.



therefore, will need no refacing. This large flange bushing must be pressed into gear case cover until outer face of bushing is just flush with machined surface of case cover to provide correct seating and clearance for oil pump. Use a smooth surfaced disc or plate a little larger than flange when pressing bushing into case cover to insure flush fit.

After new bushings have been pressed in they must be dowel pinned to prevent them from turning, by drilling a hole with a number 31 drill, 9/32" deep, through bushing flange and into aluminum so when dowel pin (Part No. 661-31) is driven in and bottomed, its end will be slightly below face of bushing flange. Peen bushing around dowel pin hole to prevent pin from coming out (see Illus. 40 or 41).

Oil holes for lubrication of cover bushings will have to be drilled in three of the bushings, with a

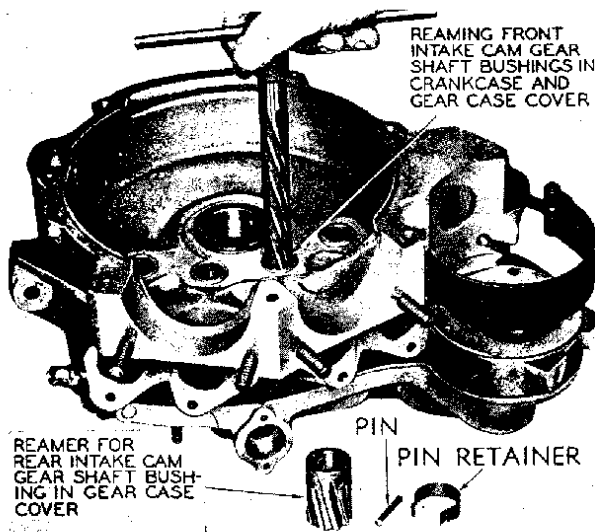

ILLUS. 44

LINE REAMING FRONT INTAKE CAM GEAR SHAFT BUSHINGS (SIDE VALVE ENGINE)

5/32" drill, using oil holes already in bushing bosses as a drill guide (see Illus. 40).

After bushings have been pressed in, dowel pinned and necessary oil holes drilled, they must be line reamed with Harley-Davidson special reamers.

**Line reaming rear intake cam gear shaft bushings:** Insert Harley-Davidson special reamer, Part No. 12133-37 through crankcase bushing from inside (see Illus. 43) but do not turn reamer in bushing as yet. Slip cover bushing reamer over end of smaller reamer and insert pin through reamers and install pin retainer (see Illus. 43). Install gear case cover, at same time starting cover bushing reamer in cover bushing. Turn reamer into crankcase and gear case cover bushings until it bottoms in gear case cover. Remove gear case cover and then remove cover bushing reamer from smaller reamer.

**Line reaming front exhaust and front intake cam gear shaft bushings:** Again install gear case cover. With cover bushing reamer removed, insert Harley-

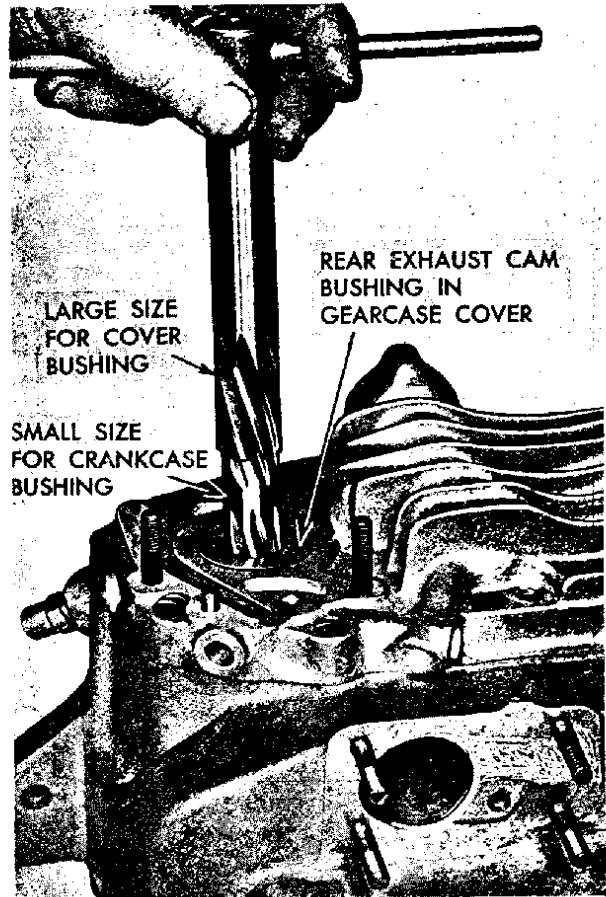

ILLUS. 45

LINE REAMING REAR EXHAUST CAM GEAR SHAFT BUSHINGS (SIDE VALVE ENGINE)

Davidson special reamer, Part No. 12133-37 through crankcase bushing, into cover bushing, and turn until it bottoms in gear case cover (see Illus. 44).

**Line reaming rear exhaust cam gear shaft bushings:** With gear case cover installed, insert Harley-Davidson special reamer, Part No. 12132-36 through bushings from gear case cover side, and turn just sufficient to size bushing holes (see illus. 45).

**Line reaming pinion gear shaft bushing:** With gear case cover installed, insert steel pilot bushing into crankcase roller race, insert Harley-Davidson special reamer, Part No. 12132-36, through pilot bushing into pinion gear shaft bushing, and turn reamer until it bottoms in gear case cover (see Illus. 46). Remove gear case cover.

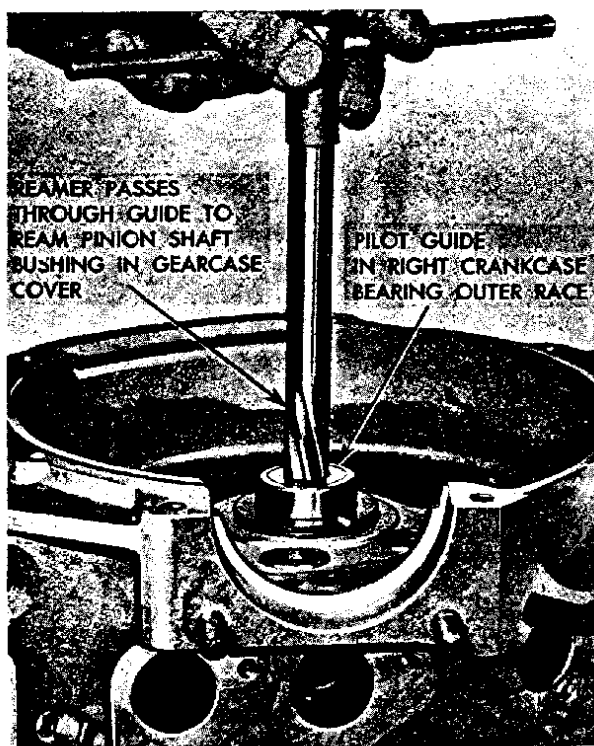

ILLUS. 46  
LINE REAMING PINION GEAR SHAFT BUSHING

Note: Illustration shows installation of reamer guide in crankcase to guide reamer when reaming bronze pinion shaft bushing in gear case cover. Cover must of course, be installed on right crankcase before starting the reaming operation. While illustration shows reaming Side Valve Engine pinion gear shaft bushing, same procedure is to be followed when reaming O.H.V. Engine pinion gear shaft bushing.

## Valve Tappets and Valve Tappet Guides

Note: Remove tappet guides and tappet assemblies if only for purpose of checking endplay of cam gears, when reassembling engine.

Inspect valve tappets for excessive clearance in guides. Also check tappet rollers for excessive bearing looseness and damaged roller faces.

Tappets and tappet guides are normally long-life parts that seldom require replacement. Tappets are originally fitted with .0005" to .001" clearance in guides. Guides are a light press fit in crankcase and are secured with screws.

Excessive tappet-guide clearance is serviced by fitting new tappet, and/or new guide. It is recommended practice to renew tappet complete when only the roller is excessively loose or otherwise in bad order; however, it is possible to renew only the roller, roller bushing and pin. If this is done, roller must turn freely and have about .008" side-play after new roller pin is securely riveted in tappet.

When end of valve tappet adjusting screw is worn

hollow from action of valve stem, it should be replaced to ensure accurate tappet-valve stem adjustment.

**O.H.V. Engine:** Exhaust tappets are interchangeable with each other, but are longer than intake tappets, and therefore, are not interchangeable with them.

Intake tappets are interchangeable with each other.

Tappet guides are not interchangeable.

To remove a tappet, it is first necessary to pull tappet guide out of crankcase. Pull tappets out to limit of travel and tie them together with piece of string or rubber band so they won't drop down. Remove tappet guide screws and drive guides out with a hammer and block of wood, resting wood against lower end of tappet guide.

Before installing a tappet and tappet guide assembly, pull the two tappets out to limit of travel and tie them together with a piece of string or rubber band so they won't drop down while installing the assembly. After installing tappet guide gasket, drive the assembly in crankcase with a hammer and block of wood, aligning screw holes in tappet guide with screw holes in crankcase as assembly is being driven in.

**Side Valve Engine:** Tappets are interchangeable.

Front exhaust and front intake tappet guides are interchangeable with each other, but are not interchangeable with rear exhaust or rear intake tappet guides. Rear exhaust and rear intake tappet guides are interchangeable with each other. If tappet guides are not located correctly in crankcase, tappet rollers will be crosswise to cams and serious damage to engine may result.

To remove a tappet, it is first necessary to pull tappet guide out of crankcase. After removing screws, pull with Harley-Davidson special puller, Part No. 11960-38 (see Illus. 47). Cam gear must be installed in case for tappet to butt against when using puller.

Before installing a tappet and tappet guide assembly, lay crankcase on its side to prevent tappet dropping into crankcase when installing the assembly. Pull tappet out to limit of travel and align screw holes in tappet guide with screw holes in crankcase. Pins of suitable length and size inserted through holes in guide and into crankcase, can be used to good advantage to maintain alignment of tappet guide during installation.

After installing tappet guide gasket, drive assembly in crankcase with hammer and a hollow drift. Front intake tappet guide for 1946 and earlier Models secures the advance and retard quadrant, with a gasket above and below quadrant.

The drift can be made from a round steel bar 15/16" diameter. Drill a 3/4" hole 2" deep for tappet clearance.

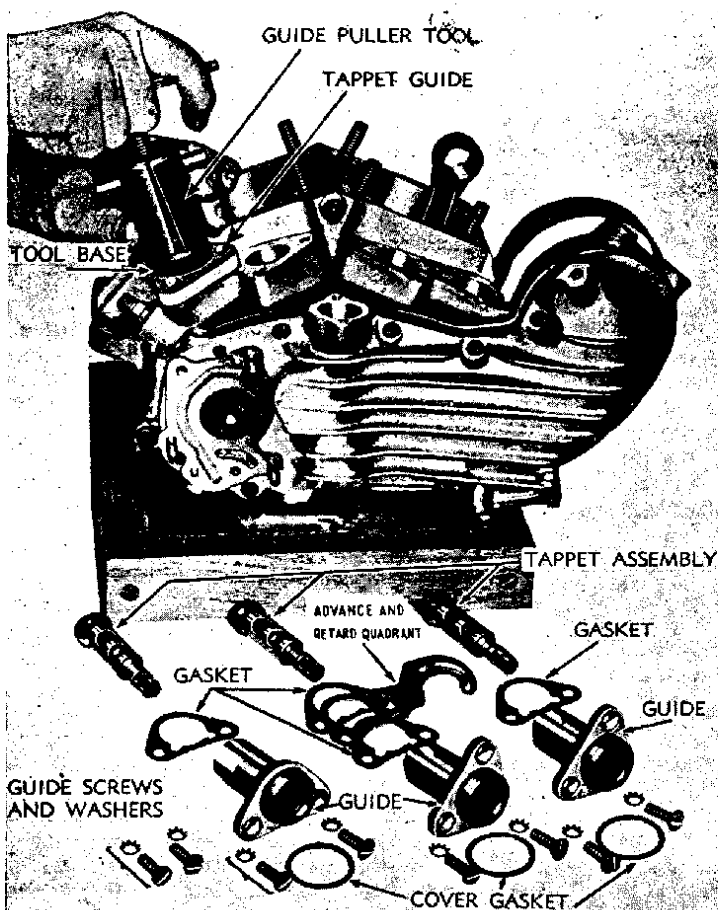

ILLUS. 47  
REMOVING TAPPET GUIDES  
(SIDE VALVE ENGINE)

Note: When pulling tappet guides with tool shown, cam gears must be installed, as tool pulls tappet guide by applying pressure against tappet and cam.

### Truing and Sizing Main Bearing Races

Before refitting worn main bearings, lap outer races to true them and remove any trace of wear shoulder at sides of roller paths using Harley-Davidson special lap, Part No. 11954-40 (see Illus. 48). Note: Before lap can be inserted in crankcase bushings, bearing washers, bearing spring rings and oil retaining bushing must be removed from the crankcase bushings. A race that is worn .0005" or more should be renewed.

When renewing main bearing races, heat cases (not over 300° F.) around races. Heating expands cases slightly and less force is required to press old races out and new races in. New races after installation, should also be lapped to smooth, true and align them; and to size them so that specified bearing clearance can be attained with roller sizes available.

When lapping main bearing races, right and left cases must be assembled and three or more studs

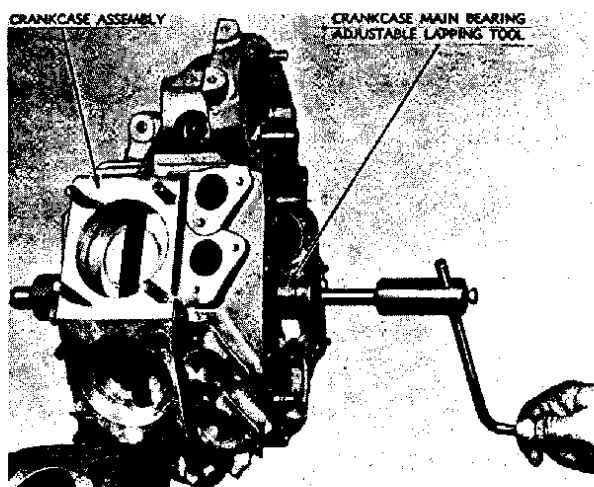

ILLUS. 48  
TRUING AND SIZING MAIN BEARING RACES

securely tightened as in final assembly; this is to assure perfect alignment between left and right races in final assembly. Lap first one side and then the other, guiding lap by means of pilot bushing in opposite race. Adjust lap snugly in race and use only a light application of fine lapping compound. A loose lap and the use of excessive amount of compound results in tapered bearing surface.

### Fitting Main Bearings

When fitting main bearings, the shafts that are to be used when flywheels are reassembled can be used as gauges (see Illus. 49) with which to determine when bearings are fitted to correct clearance. Use the largest roller size that will allow shaft just noticeable shake in bearing. Bearing must not be fitted so tight that shaft has no shake at all. In making this check, all bearing parts must be perfectly clean and dry; oil in the bearing will take up some clearance and make bearing feel tighter than it is actually fitted. Sprocket shaft clearance in left main bearing should be .0005" to .001"; pinion gear shaft clearance in right main bearing should be .0008" to .0012".

After main bearing fitting is completed, crankcases with roller and retainer assembly can be set aside until flywheels are assembled.

Mainshafts can now be installed to their respective flywheels, sprocket shaft to left (heavier) flywheel, pinion gear shaft to right (lighter) flywheel. Wipe shaft tapers and flywheel tapers perfectly clean and free of oil. Be sure keys are in place. Tighten nuts very tight, using Harley-Davidson special wrench, Part No. 11933-X. Install lock washers. Lock washer can be installed either side up as it best matches lock screw hole. If necessary, tighten nut a trifle more to make lock screw holes match. Install lock screw and tighten securely.

After right side (pinion gear) shaft is installed check oil passage through shaft and side of flywheel with compressed air, to be sure passage is open.

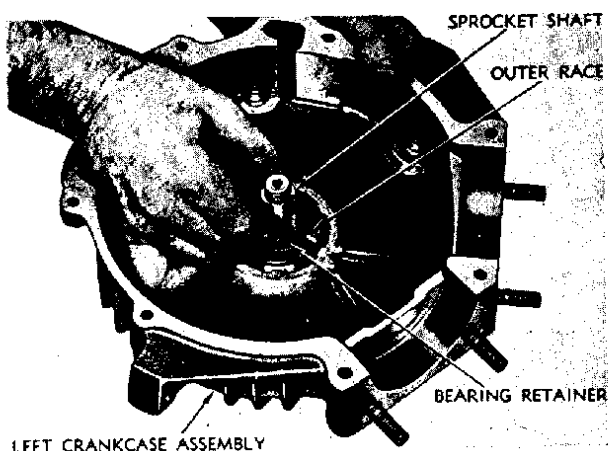

ILLUS. 49  
USING SPROCKET SHAFT AS GAUGE TO DETERMINE BEARING FIT

### Servicing Flywheels and Installing Crank Pin

First give attention to flywheel washers (24), Illus. 62 or 63. If washer in either flywheel is worn and grooved to any extent, it should be renewed. This hardened steel washer fits into recess in flywheel face around crank pin hole and takes side thrust of connecting rod lower end and bearing. Washer is a close fit in recess and is secured by punching flywheel metal tight against it at several points around outer edge of washer.

To remove washer, it is ordinarily necessary to drill a small hole ( $\frac{1}{8}$ " or smaller) at the outer edge of washer to permit getting a pointed tool underneath and prying it out. This hole should be small and should be drilled only to slightly greater depth than thickness of washer. Drilling hole too large or too deep weakens flywheel and it may crack at that point. Before installing new washer, scrape outer edge of recess where metal was punched against old washer and thoroughly clean recess, as new washer must seat fully against recess bottom. If washer is carelessly installed and does not seat fully in recess, female (forked) rod is not likely to have required sideplay when flywheels are assembled.

Crank pin can now be installed in right flywheel. Wipe pin taper and flywheel taper perfectly clean and free of oil. Be sure key is in place. Tighten nut very tight, using Harley-Davidson special wrench, Part No. 11933-X. Install lock washer as it best matches lock screw hole—some washers can be installed either side up, others have two screw holes. If necessary, tighten nut a trifle more to make lock screw holes match. Install lock screw and tighten securely.

Check oil passage through pinion shaft, right flywheel and crank pin, with compressed air. Be sure this passage is open.

### Truing and Sizing Connecting Rod Lower Races

In lapping a set of worn rods (use Harley-Davidson special lap, Part No. 11944-36), lap until no trace of wear shoulder is left at sides of roller path; also lap both rods to fit same size rollers.

When rod lower races are damaged or worn beyond truing up and refitting with largest oversize rollers, rods must be replaced with new or returned to factory for refitting with new lower races. It is not practical for other than the factory to renew these races as they are distorted considerably when pressed into rods and the initial truing must be done with a grinder; lap is intended only for smoothing up and resizing races, worn or not exactly the right size.

Turn lap in lathe 150 to 200 R.P.M. (see Illus. 50). When means of turning lap are not at hand, hold in vise and turn rod. Adjust lap to snug fit in race before applying lapping compound; a loose lap will "bell mouth" bearing race. Apply light coat of fine lapping compound. To avoid grooving or tapering lap, work rod back and forth along its full length.



New rods ordered from the factory or used rods returned to the factory for rebushing are usually ordered fitted with crank pin and rollers. If not, they are likely to need lapping to fit available rollers with specified clearance.

After it has been determined that lower end races are in good enough condition to be lapped and re-fitted, upper end bushings should be inspected for need of attention. Check bushings for looseness in rods as well as pin clearance (see "Installing and Fitting Connecting Rod Upper Bushing," Page 90).

Rods that have been returned to the factory for new lower end races will also be fitted with new upper end bushings, reamed to correct clearance for standard pin. This, of course, also applies to new rods.

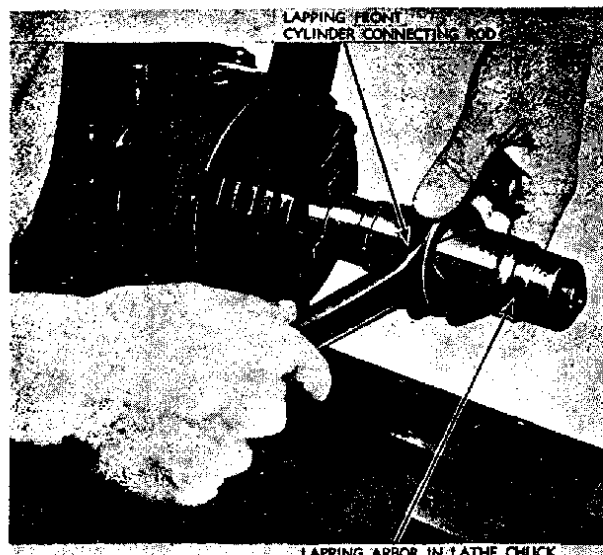

ILLUS. 50

TRUING AND SIZING CONNECTING ROD LOWER RACE

### Determining Correct Lower Bearing Fit

(See "Checking Connecting Rod Lower Bearing for Excessive Wear and Looseness," Page 40, for information on checking lower bearing in connection with top overhaul and how much looseness may be allowed before bearing must be refitted.)

After lapping lower races of used rods as necessary, to smooth and true them, or replacing rods with a set with new lower races, install set of rollers and retainers on crank pin; rollers must always be new. Check fit of rods on bearing assembly. In making this check, flywheel pinion gear shaft must be gripped tightly between copper-faced vise jaws to hold flywheel firmly in a horizontal position. If neither rod will start over bearing, select a smaller set of rollers. If they go over easily and there is considerable shake at top end of rods, install a larger set of rollers. If lower end race of one rod is found to be slightly larger than the other, select rollers of a size that come closest to correctly fitting larger rod race and then lap rod with smaller race to bring it

up to same size, rather than fit with rollers of two sizes.

When rods are correctly fitted with required bearing clearance, extreme upper end of female (forked end) rod will have just noticeable side shake; extreme upper end of male (single end) rod will have .025" to 1/32" side shake. This check should be made with bearings clean and free of oil. Fitting tighter is likely to result in a seized and damaged bearing shortly after engine is put back in service.

Overall width of roller retainer assembly must be less than width of female rod end. Check to be sure of this.

### Assembling Connecting Rods and Flywheels

After correct connecting rod bearing fit has been attained, thoroughly clean all parts and lubricate with engine oil preparatory to assembling flywheels. Install connecting rods on crank pin bearing so female (forked end) rod will be to rear and male (single end) rod will be to front.

With right side flywheel and rod assembly held in vise copper jaws, wipe crank pin taper and left flywheel taper perfectly clean and free of oil, then install left flywheel and align as nearly as possible concentric with right wheel by means of a straight edge held against outer face of wheel rims, 90° from crank pin—see Illus. 51. Install nut on crank pin and tighten lightly. Check rim faces again with straight edge and, if tightening nut has shifted wheel, correct its position by striking rim of wheel with a lead or copper hammer. Do not use steel hammer. Turn nut tighter and repeat straight edge check. To prevent flywheel assembly from turning in vise while tightening nut, insert a rod approximately 1/2" diameter and at least 5" long through holes in flywheels and shift flywheels in vise jaws so that rod bears against some part of vise.

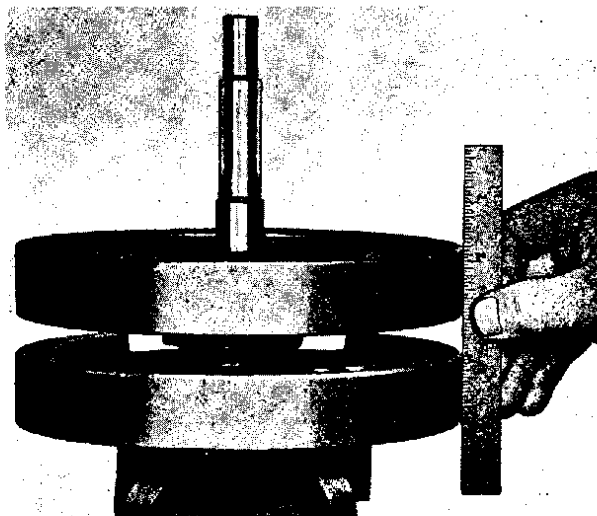

ILLUS. 51

CHECKING FLYWHEEL RIM FACES



After nut has been turned fairly tight, install flywheel assembly in truing device as shown in Illus. 53, and true according to indicators (see "Truing Flywheels)."

Remove wheels from truing device, again hold in vise as before and securely tighten crank pin nut. Pull this nut very tight. Now check the sideplay of female (forked) rod between flywheels (see Illus. 52). Sideplay should be .006" to .010". Check with thickness gauge. Push the rod end tight against one wheel and insert thickness gauge between rod and other flywheel. If it is found that there is too much sideplay, probably all or most of the excess play can be taken up by pulling crank pin nuts a little tighter. If there is not enough play, it is due to one of the following conditions: Flywheels and crank pin assembled with oil on tapers and nuts over-tightened (crank pin nuts must be pulled very tight but, of course, tightening can be overdone); new flywheel washers installed and not fully seated (see "Servicing Flywheels and Installing Crank Pin," Page 60); tapered holes enlarged as a result of flywheels having been taken apart and reassembled several times in connection with previous overhauling; a flywheel cracked at tapered hole.

In a case like this, the first thing to do is recheck flywheel washers. If these washers are found fully seated and secured in flywheels, the next best thing to do is determine which flywheel seats farthest on crank pin taper, due to enlarged tapered hole or crack, and replace that wheel with a new one. Another thing that can be tried is exchanging crank pin for another new one. However, there is ordinarily very slight variation in length of crank pins. As a last resort, side faces of forked rod lower end can be ground off as necessary to gain required sideplay. If this is done, backs of retainers may also need to be ground off slightly as retainer assembly must, in every case, be narrower than female (forked) rod.

After rod sideplay has been checked and adjusted, crank pin nut pulled very tight and nut lock washer installed, again install wheel assembly in truing device and recheck for trueness.

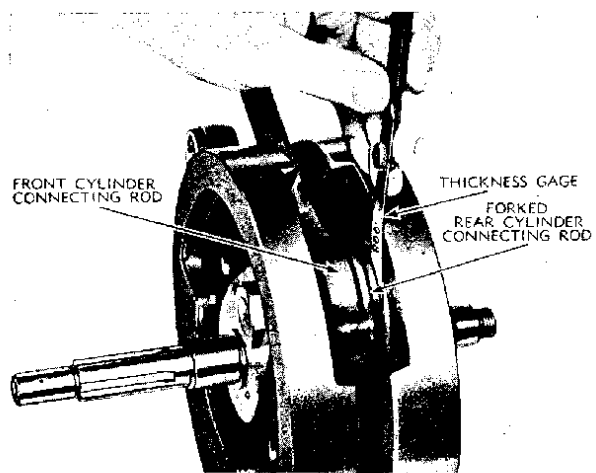

ILLUS. 52  
CHECKING CONNECTING ROD SIDE PLAY

**CAUTION:** After flywheels and rods are assembled, make final check to be sure oil passage is open to rod roller bearing. Apply compressed air to oil hole in side of pinion shaft, near its outer end, and observe that air escapes around connecting rod lower end. If this passage becomes blocked (closed off) in some manner and engine is assembled and put in service with it blocked, engine will get no lubrication, except in the timing gear case. This is not likely to be detected until serious damage has been done, as the oil circulation indicator in instrument panel will give no warning when the oiling system is blocked in this passage.

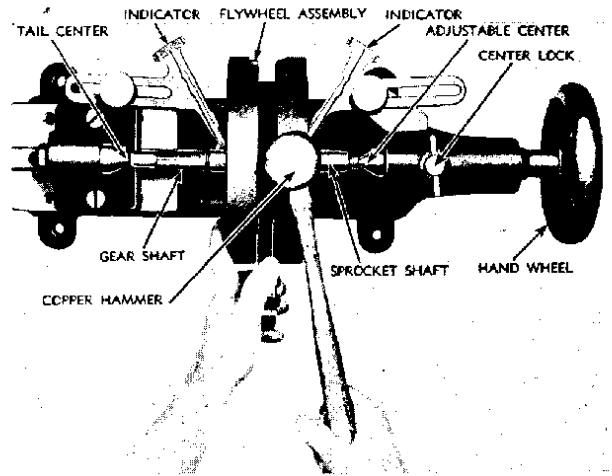

ILLUS. 53  
TRUING FLYWHEEL MAINSHAFTS

### Truing Flywheels

Bear in mind that, while a straight edge across rim faces is used when assembling flywheels to keep them as near as possible true with each other, final truing is a matter of truing sprocket shaft and pinion gear shaft to perfect alignment with each other, rather than truing flywheel rims. Install wheel assembly in truing device (Harley-Davidson truing device, Part No. 11962-X) and adjust so that centers are just snug (wheels must turn freely). If flywheel assembly is either loose between centers or is squeezed, indicators will not indicate accurately. Indicators should be adjusted as closely as possible to flywheels, and so that pointers rest about in the middle of graduated scales (see Illus. 53).

Turn flywheels and observe the movement of indicator pointers. Movement of pointers toward flywheels indicate high points of shafts. Find highest point of each shaft and chalk-mark flywheel rims at those points. Loosen centers slightly, just enough so it can be detected that flywheel assembly is a trifle loose. Turn high point of first one flywheel and then the other to the top and strike rim of wheel one or more sharp blows with a lead or copper hammer. The number of blows required and how hard they should be depends, of course, on how far shafts are out of true. Remember that centers

should be loosened slightly before striking flywheels. However, they should not be loosened to the extent of allowing flywheels considerable play between centers, as making them very loose is likely to result in broken or damaged centers.

After striking wheels with hammer as explained above, readjust centers to just snug and again turn wheels and check with indicators. Repeat the truing operation until indicators show within .001" of true. Each graduation on indicator scale is approximately .002"; therefore, when shafts are true within requirements, neither indicator will move more than about one-half graduation.

In the case of a flywheel assembly that is considerably out of true and which cannot be trued up by following the procedure described, it may be due to crack at one of the flywheel shaft holes or a damaged and enlarged tapered hole. If used sprocket and pinion shafts are assembled in flywheels, it may be due to one of these shafts being worn considerably out of round at the point where indicator takes bearing against it.

### Assembling Crankcases

Flywheels are now ready to be assembled into crankcases which have already been given due attention as concerns main bearing fitting (see "Fitting Main Bearings," Page 60). A strong rack or box with an opening about 8" x 8" and at least 4" deep should be available, on which to place right crankcase on its side. *O.H.V. Engine:* With pinion gear shaft bearing spring ring engaged in groove in roller race, install bearing washer, bearing assembly and bearing spacer as shown in Illus. 62. *Side Valve Engine:* With pinion gear shaft bearing spring ring engaged in groove in roller race, install bearing washer and bearing assembly in the order shown in Illus. 63.

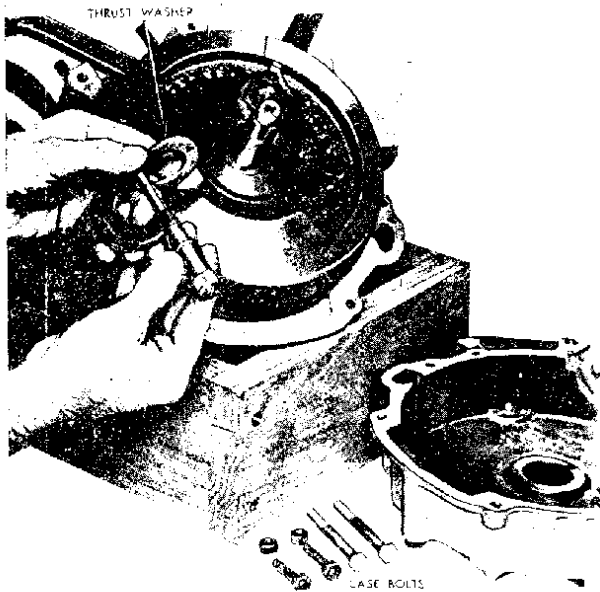

ILLUS. 61  
MEASURING THICKNESS OF FLYWHEEL THRUST WASHER

*All Models:* Select two flywheel thrust collars and install one on each flywheel hub. Be sure they register on dowel pins and seat fully against wheel faces. These collars come in various thicknesses (.066" to .102" in steps of .004") to permit adjusting flywheel endplay between crankcases. The only way to determine exactly what collar thickness is required is to try one set and then another until the correct endplay is attained. The average thickness of collars used in new engine assembly is about .086". Both collars should be approximately the same thickness in order to keep flywheels centered in crankcases and connecting rod upper ends centered between piston pin bosses.

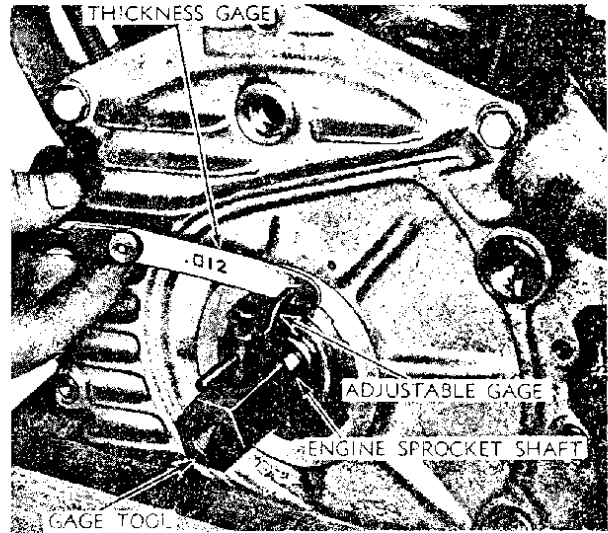

ILLUS. 65  
CHECKING ENDPLAY OF FLYWHEEL ASSEMBLY IN CRANKCASE

When a set of collars has been selected and installed on flywheels, install flywheel assembly into right crankcase. Install sprocket shaft roller bearing assembly and bearing washer on sprocket shaft in the order shown in Illus. 62 or 63, and install left crankcase. No gasket is used on crankcase center joint, and joint should not as yet be coated with gasket cement or sealer. Insert stud at top center of cases and two studs at bottom of cases. Install and tighten nuts to clamp cases securely together.

Now, by pushing back and forth on ends of sprocket and pinion shafts, check flywheel endplay. If no endplay is found, cases will have to be taken apart and thinner thrust collars installed. Reassemble and again check endplay. If it is found that flywheels now have endplay continue check with Harley-Davidson endplay gauge, Part No. 11967-38, as follows: Install endplay gauge on sprocket shaft, and adjust gauge pin to just touch crankcase when flywheel is pressed toward gear case side. Now push flywheel toward left side case and use a thickness gauge to determine amount of flywheel endplay (see Illus. 55). When this has been accurately determined, it is then a simple matter to calculate how much thinner or how much thicker thrust collars

must be installed to attain correct endplay (.012" to .014").

After selecting and installing thrust collars of correct thickness, oil main bearings and proceed with final assembly.

Give both faces of crankcase center joint a moderate application of gasket cement or sealer.

After allowing cement or sealer to air-dry a few minutes, assemble crankcases, install all studs, nuts and cap screws and tighten securely. Remember, three of the crankcase studs, the one at top center and the two bottom studs, are drive fit studs that locate crankcases in exact relation to each other. These studs must not be replaced with loose-fit studs. After crankcase assembly is completed, recheck to be sure flywheels have at least the specified minimum endplay.

### Installing Generator

Install generator idler gear:

*O.H.V. Engine*—install idler gear (5), Illus. 64, spacer and lock ring on stud.

*Side Valve Engine*—install idler gear (11), Illus. 65, fibre thrust washer and lock ring on stud.

The metal shim (.014" thick), used with standard generator fitted with larger diameter drive gear (later O.H.V. Models only), is to be placed directly on cradle with paper shims above. See "Removing Generator," Page 97.

*All Models:* Inspect generator drive end gasket and if damaged replace with a new one. Secure gasket

to generator end with gasket cement or sealer.

If the original number of paper shims are at hand, use them when installing generator. If original paper shims are not available, then start out with three new shims (shim is approximately .004" thick) placed between generator frame and its cradle.

If generator frame has a small oil drain hole near the drive end, be sure holes in shims line up with hole in generator frame and hole in cradle, so drainage will not be blocked. However, some generators may not have a drain hole in frame and in that case disregard holes in shims. Just a small amount of grease applied to shims and cradle will hold shims in place while installing generator.

With shims in place on cradle, install generator and assemble convex washer, lock washer and nut on strap end, but do not tighten nut as yet.

Insert, temporarily, the two long screws that secure generator to timing gear case. Inasmuch as gear case cover is not yet installed, its thickness will have to be taken up by suitable spacers (nuts or collars) under screw heads to permit screws to be tightened. Tighten mounting screws snugly (not tight); then tighten generator mounting strap nut. Now loosen mounting screws to allow generator to adjust itself, and then tighten these screws securely.

Check lash between generator drive gear and idler gear. Try this at several points around gears. If it is found that gears have considerable lash, remove one or more paper shims from underneath generator. Gears must not, however, be meshed so deeply that no noticeable lash can be felt between all teeth as gears are turned.

### Memoranda



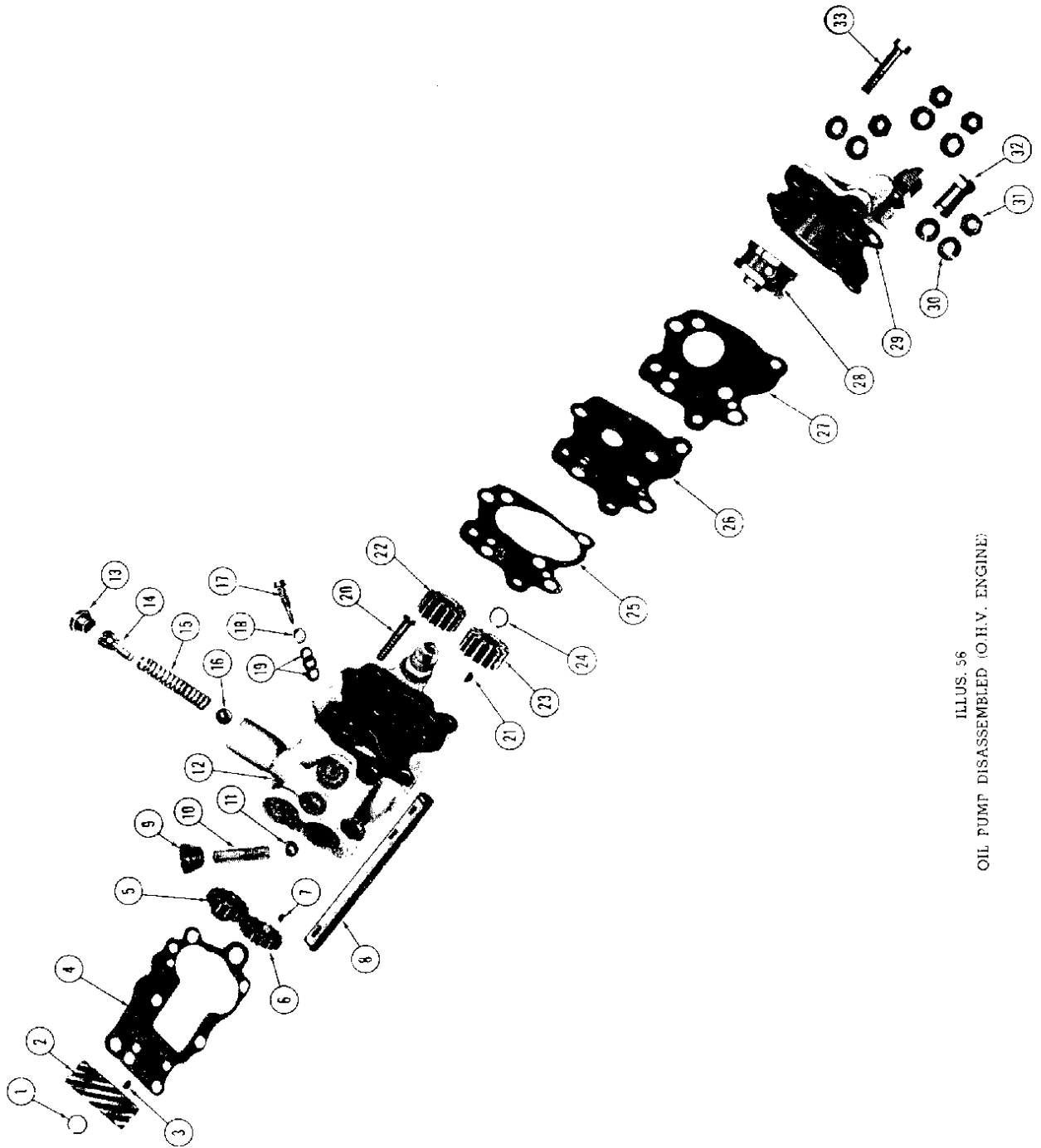

ILLUS. 56  
OIL PUMP DISASSEMBLED (O.H.V. ENGINE)



## OIL PUMP ASSEMBLY (O. H. V. ENGINE)

(Item Numbers Refer to Illus. 56)

ITEM	NUMBER USED		PART NUMBER		NAME
	1940	1941 AND LATER	1940	1941 AND LATER	
1	2	2	695-36	695-36	Oil Pump Drive Shaft Spring Ring (same as Item 24)
2	1	1	623-39	623-39	Oil Pump Drive Shaft Gear
3	2	2	634-15	634-15	Oil Pump Drive Gear Key (same as Item 21)
4	1	1	589-36	589-41	Oil Pump Body Gasket
5	1	1	689-36	689-36	Oil Feed Pump Idler Gear
6	1	1	688-36	688-36	Oil Feed Pump Gear
7	1	1	693-36	693-36	Oil Feed Pump Gear Key
8	1	1	638-36	638-36	Oil Pump Drive Shaft
9	1	1	701-36	701-36	Check Valve Chamber Cap Screw
10	1	1	703-36	703-36	Check Valve Spring
11	2	2	704-36	704-36	Check Valve (same as Item 16)
12	1	1	678-36	678-41A	Oil Pump Body
13	1	1	707-36	707-36	Pressure Regulating Valve Chamber Cap Screw
14	1	1	711-36	711-36	Pressure Regulating Valve Adjusting Screw
15	1	1	713-39	713-42	Pressure Regulating Valve Spring
16	See Item 11				Pressure Regulating Valve
17	1	1	672-32	672-32	Front Chain Oiler Adjusting Screw
18	1	1	0202	0202	Front Chain Oiler Adjusting Screw Washer (.0625" thick)
19	Varies	Varies	674-32	674-32	Front Chain Oiler Adjusting Screw Washers (.002" thick)
20	...	1	.....	692-41A	Oil Pump Mounting Screw
21	See Item 3				.....
22	1	1	691-36	691-36	Oil Scavenger Pump Idler Gear
23	1	1	690-36	690-36	Oil Scavenger Pump Gear
24	See Item 1				.....
25	...	1	.....	684-41	Oil Pump Cover Plate Gasket
26	...	1	.....	683-41	Oil Pump Cover Plate
27	1	1	685-36	685-41	Oil Pump Cover Gasket
28	...	1	.....	687-41C	Oil Pump Governor Rotor
29	1	1	682-36	682-41	Oil Pump Cover
30	6	6	0256	0256	Lock Washer
31	6	4	0108	0108	Oil Pump Mounting Stud Nut
32	...	1	.....	591-41A	Oil Pump Mounting Stud Nut
33	...	1	.....	692-41	Oil Pump Mounting Bolt

Note: A few motorcycles are equipped with rear chain oiler, however, parts for installing rear chain oiler, or for replacement are no longer available.

Standard pump parts shown in illustration that differ from parts used with rear chain oiler are items 23, 26, 27 and 29.

ILLUSTRATION 57  
OIL FEED PUMP AND SCAVENGER PUMP  
DISASSEMBLED (SIDE VALVE ENGINE)

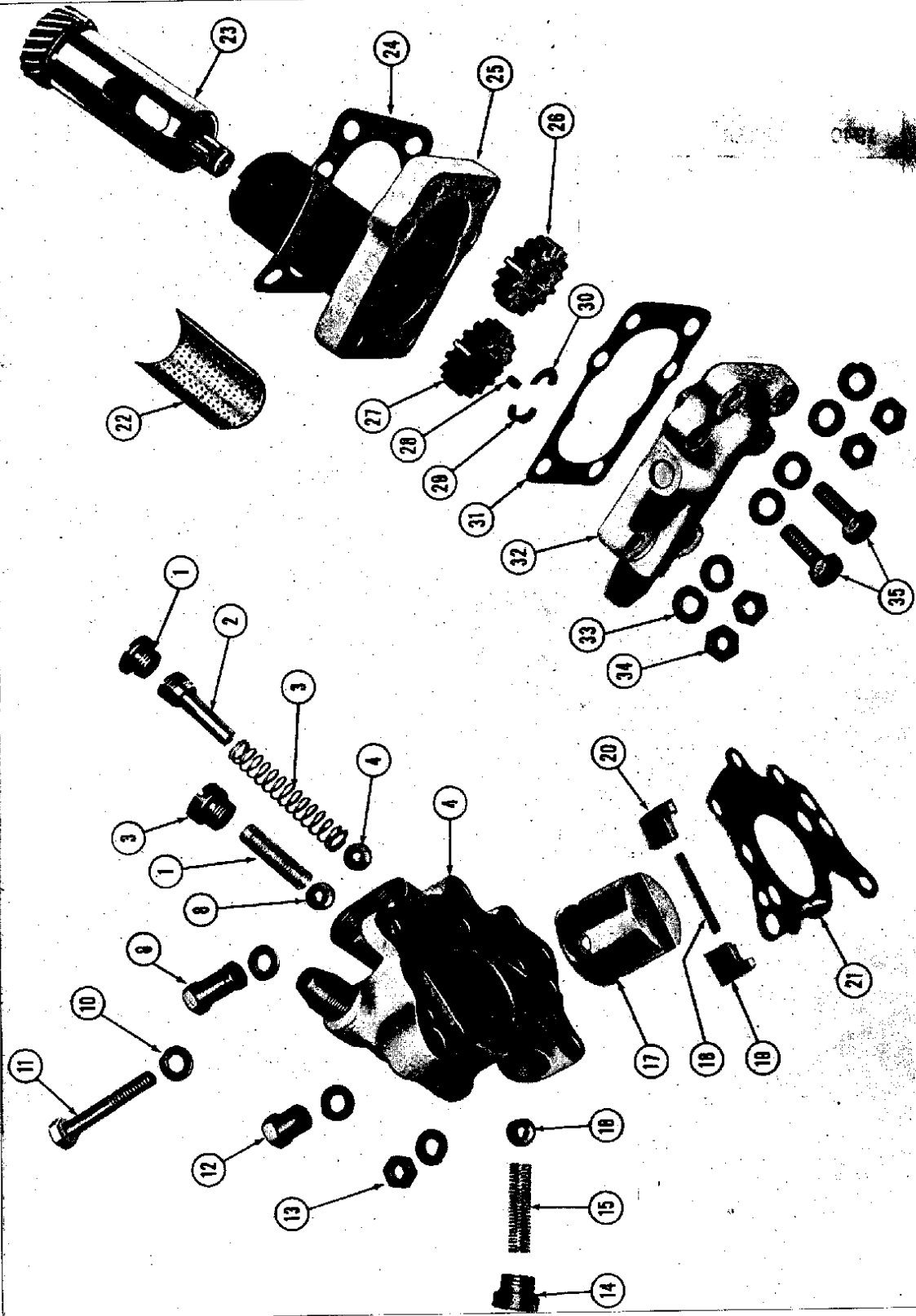

# OIL FEED PUMP AND SCAVENGER PUMP ASSEMBLIES (SIDE VALVE ENGINE)

(Item Numbers Refer to Illus. 57)

ITEM	NUMBER USED	PART NUMBER	NAME
1	1	707-36	Pressure Regulating Valve Chamber Cap Screw
2	1	711-41	Pressure Regulating Valve Adjusting Screw
3	1	713-41	Pressure Regulating Valve Spring
4	3	704-36	Pressure Regulating Valve (same as Items 8 and 16)
5	1	678-41	Oil Feed Pump Body
6	2	701-36	Check Valve Chamber Cap Screw (same as Item 14)
7	2	703-36	Check Valve Spring (same as Item 15)
8	See Item 4	.....	Check Valve
9	1	591-41A	Oil Feed Pump Mounting Stud Nut
10	4	0256	Lock Washer
11	1	591-37A	Oil Feed Pump Mounting Cap Screw
12	1	591-41	Oil Feed Pump Mounting Stud Nut
13	1	0108	Oil Feed Pump Mounting Stud Nut
14	See Item 6	.....	.....
15	See Item 7	.....	.....
16	See Item 4	.....	Check Valve
17	1	687-41	Oil Feed Pump Rotor
18	1	689-37	Oil Feed Pump Vane Spring
19	2	688-37	Oil Feed Pump Vane (same as Item 20)
20	See Item 19	.....	.....
21	1	589-37	Oil Feed Pump Gasket
22	1	504-39	Oil Scavenger Pump Screen
23	1	503-37	Breather Valve
24	2	590-37	Oil Scavenger Pump Gasket (same as Item 31)
25	1	679-37	Oil Scavenger Pump Body
26	1	691-37	Oil Scavenger Pump Idler Gear
27	1	690-37	Oil Scavenger Pump Gear
28	1	693-36	Oil Scavenger Pump Gear Key
29	2	694-37	Split Key (same as Item 30)
30	See Item 29	.....	.....
31	See Item 24	.....	.....
32	1	682-37	Oil Scavenger Pump Cover
33	6	0256	Lock Washer
34	4	0108	Oil Scavenger Pump Mounting Stud Nut
35	2	053B	Oil Scavenger Pump Cover Cap Screw

Note: A few motorcycles are equipped with rear chain oiler, however, parts for installing rear chain oiler, or for replacement, are no longer available, except for Servi-Car.

Standard pump parts shown in illustration that differ from parts used with rear chain oiler are Items 27 and 32.

## Servicing Scavenger Pump (Side Valve Engine)

(To Identify Items, Refer to Illus. 57)

The crankcase breather valve (23) is an integral part of the scavenger (oil return) pump. The breather valve (which drives scavenger pump gears) is driven by a spiral gear located on engine pinion gear shaft. Breather valve must be accurately timed to control the scavenging of oil from engine crankcase. A few motorcycles are equipped with rear chain oiler, in which case the scavenger pump provides oil for rear chain lubrication. Breather valve and scavenger pump give very little trouble and ordinarily a thorough cleaning is all the service required.

Thoroughly clean exterior of pump in gasoline or cleaning solvent before disassembling.

Remove the two cover cap screws (35) and separate cover (32) from pump body, exercising care not to damage paper gasket (31). With cover removed, pump gears (26) and (27) are exposed. Pump gear (27) is keyed on breather valve end, and pump idler gear (26) idles on cover stud. Remove the split keys (29) and (30) from end of breather valve, and pump gear is then free for removal.

After pump gears have been removed, remove gear key (28) and pull breather valve out of pump body.

If pump is provided with rear chain oiler, remove adjusting screw and adjusting screw washers so that cover oil channels may be cleaned out.

Clean all parts thoroughly in gasoline or cleaning solvent. Blow out oil holes and passages with air.

Inspect breather valve spiral gear teeth for good condition. Inspect pump body and cover for breaks, cracks, or other damage that requires replacement of these parts.

Any damaged and/or badly worn parts should be replaced. If breather valve is damaged, it is advisable to replace entire unit.

All parts must be thoroughly clean before assembling. Do not install pump until crankcase has been assembled and pinion shaft gears installed, ready for timing.

Apply engine oil to all moving parts before assembling. Install breather valve (23). Install key (28) in keyway in end of breather valve and install pump gear (27), registering keyway with key. Install split keys (29) and (30). If cover gasket (31) is to be replaced do not use other than a "factory-made" gasket. This gasket is special as concerns thickness. Locate gasket on pump body after applying engine oil to face of gasket to hold it in place. Install pump idler gear (26) on cover stud and assemble cover and gear on pump body. Install the two cover cap screws and lock washers but do not tighten screws until after pump has been installed.

If pump is provided with rear chain oiler, make sure that all the oiler adjusting screw washers removed when pump was disassembled, are reinstalled when installing adjusting screw. Final adjustment of rear chain oiler cannot be determined until motorcycle is placed in service. See "Lubricating Drive Chains," Page 12.

### Installing Scavenger Pump (Side Valve Engine)

Install gear shaft bearing oil seal ring (32), Illus. 63, on pinion gear shaft. Locate the semi-circular screen (22), Illus. 57, between breather valve housing and crankcase port, before installing scavenger pump. A recess is machined in rear side of crankcase port chamber to accommodate the screen which is held in place by breather valve housing. The breather valve must be timed so the elongated ports in valve sleeve and breather valve housing align at the correct time for proper scavenging of oil from engine crankcase.

See that crankcase and pump body faces are clean and that gasket is in good condition and in place (a light film of oil will hold gasket in place) and install pump. Install washers and nuts on pump mounting studs and securely tighten nuts and cap screws.

After nuts and cap screws have been securely tightened, and before installing gears on pinion gear shaft, make sure pump gears turn with little or no binding. While a very slight bind or drag is permissible, gears should be adjusted to turn as freely as possible. Binding is caused by slight misalignment of cover. If there is more than just noticeable bind, loosen mounting stud nuts and cap screws and shift cover as needed using a hammer and block of hard wood, resting wood radially against cover.

It will not be possible to determine before hand in

which direction cover must be shifted and it may require several attempts from different angles before alignment is correct.

Time breather valve as per instructions under "Timing Crankcase Breather Valve (Side Valve Engine)."

**CAUTION:** Breather valve controls the scavenging of oil from crankcase. Unless it is accurately timed as per instructions, oiling system will not function normally.

### Timing Crankcase Breather Valve (Side Valve Engine)

(Refer to Illus. 63)

Install oil seal ring spring (33), breather valve and scavenger pump spiral drive gear (34), and pinion gear (35) on pinion shaft in order named. A mark is cut in one side of spiral drive gear. Install with marked side outward (against pinion gear). Now refer to Illus. 58. Item numbers of comparative items differ from those shown in Illus. 63. Turn engine until flywheel timing mark is exactly in center of timing inspection hole in left crankcase. Push gears inward, compressing spring and engage spiral drive gear and breather sleeve gear (E) so hole (4) in sleeve is in center of breather housing slot when pinion gear is set and held with its outer face (3) 7/16" from gear case joint face (this is actual location of pinion and spiral gears on pinion shaft when gear case cover is in place). It may require several

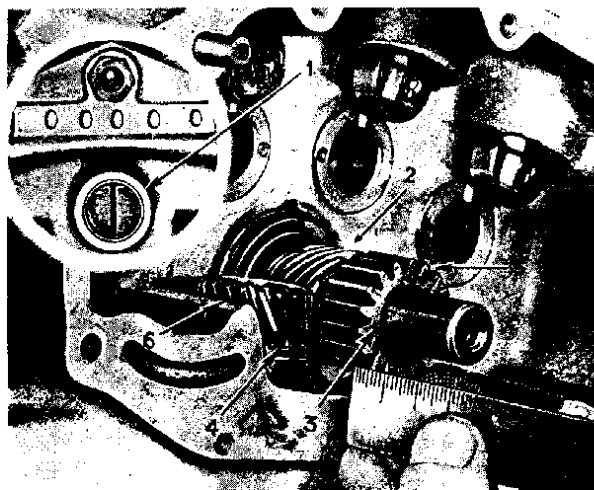

ILLUS. 58  
TIMING CRANKCASE BREATHER VALVE (SIDE VALVE ENGINE)

1. Inspection hole in left crankcase showing flywheel timing mark exactly in center of hole.
2. Breather pinion shaft gear (spiral gear).
3. Outer face of pinion gear—must be 7/16" from gear case joint face when timing breather.
4. Timing hole in breather sleeve: registering in center of slot in bushing.
5. Pinion gear; slip fit on shaft.
6. Crankshaft breather sleeve gear; also drives scavenger oil pump.

attempts before spiral gear and sleeve gear can be meshed to give desired results.

Summarizing the above breather timing instructions: Spiral drive gear (2) must be so engaged with breather sleeve gear that when flywheel mark is in center of inspection hole and pinion gear (5) is held with its outer face (3)  $7/16$ " from gear case joint face, timing hole (4) in breather sleeve registers in breather housing slot as shown.

After timing breather valve, exercise care that breather timing gears are not pulled out of mesh, permitting timing to change, while installing valve timing gears.

**CAUTION:** The breather is a part of and drives scavenger oil pump underneath gear case. If there is occasion to remove scavenger pump, breather will of course come out with it. Removing does not require taking off gear case cover. However, it must be remembered that in order to reassemble with breather timed, it is necessary to take off gear case cover and follow the foregoing timing instructions.

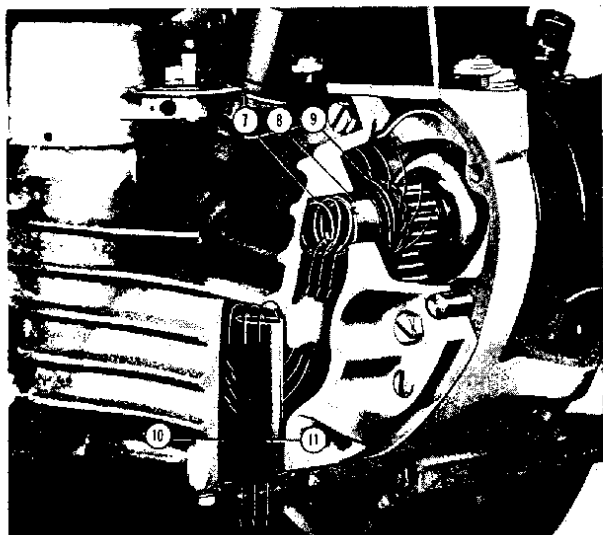

ILLUS. 59  
CRANKCASE BREATHER (SIDE VALVE ENGINE)

7. Oil seal ring spring.
8. Oil seal ring—must bear against centrifuge.
9. Oil centrifuge—separates oil from air by centrifugal force, allowing only air and a slight oil mist to escape through holes in periphery of centrifuge.
10. Outside breather oil trap.
11. Outside breather tube—through which air, after having been separated from oil is exhausted to atmosphere.

### Servicing Oil Pump (O.H.V. Engine)

(1941 to 1947 Models)

(To Identify Items, Refer to Illus. 56)

Oil feed pump and scavenger (oil return) pump are gear type pumps incorporated in one pump body. Feed pump incorporates an automatic (centrifugal) by-pass valve, reducing oil feed supply at low engine speeds and increasing supply at high engine speeds.

Pump is provided with check valve (11) and adjustable pressure regulating valve (16). Maximum pressure is approximately 30 pounds per sq. in.

Thoroughly clean exterior of pump in gasoline or cleaning solvent before disassembling.

With cover (29), governor rotor (28) and cover plate (26) and gasket (27), already removed, scavenger pump gears (wide gears) (22) and (23) are exposed. Scavenger pump gear (23) is keyed on pump drive shaft (8) and idler gear (22) idles on stud in pump body.

Remove lock ring (24) from end of pump drive shaft and slide gears off shaft and stud respectively. Remove scavenger pump gear key (21) from pump drive shaft.

Drive shaft can now be pulled out of pump body. Oil feed pump gears (narrow gears) (5) and (6) are now free for removal, however, gear (6) may come out with drive shaft. Remove drive gear key (7) from drive shaft.

Remove chamber cap screws (9) and (13), adjusting screw (14), springs (10) and (15) and valves (11) and (16).

Remove front chain oiler adjusting screw (17) and adjusting screw washers (18) and (19). If pump is fitted with rear chain oiler, remove adjusting screw and adjusting screw washers.

Clean all parts in gasoline or cleaning solvent and blow out all pump body passages with air.

Using a light, inspect valve seats in pump body for pits and for dirty condition. Note: A small particle of foreign matter lodged on valve seat will prevent valve from seating, thus preventing correct operation of pump. Replace pump body if seats are damaged.

Inspect springs for breakage and rusted condition. Replace if not in good condition. Free length of new pressure regulating (by-pass) valve spring (15) is approximately  $1-31/32$ ".

Check valve spring (10) is the same for all pumps but is not interchangeable with any pressure regulating (by-pass) valve spring. It is much lighter (has less tension) than pressure regulating (by-pass) valve spring. Free length of check valve spring is approximately  $1-9/32$ ".

Valves (11) and (16) are interchangeable for check valve or pressure regulating (by-pass) valve and are the same for all pumps. Valves may have rings formed by action on valve seats. Valves not perfectly smooth and round should be replaced.

Governor rotor (28) and rotor chamber in pump cover (29) ordinarily show no appreciable wear, and very seldom need replacing.

Make sure that all parts and valve seats and all passages in pump body are thoroughly clean and free from dust, dirt, or grit before assembling. Also make sure valve in governor rotor (28) works freely, as a sticking valve will likely result in over-oiling at lower speeds.

Install check valve (11) and spring (10) and secure with cap screw (9). Install pressure regulating (by-



pass) valve (16), spring (15), and adjusting screw (14), turning in adjusting screw until end of screw is  $\frac{3}{8}$ " below end of valve chamber. This is normal setting. See "Adjusting Oil Feed Pump," Page 28.

To complete assembling of oil pump reverse procedure followed in disassembling. Note that one of the three gear keys, (7), is smaller than other two—install this key in shaft for oil feed pump gear (6) (narrow gear).

Some pumps may have a thin (.003") spacer behind scavenger pump idler gear (22) and gear will be .497" wide. Other pumps will have no spacer behind scavenger pump idler gear and gear will be .500" wide. A gear .497" wide should be used with spacer but a gear .500" wide must not be used with spacer. To exceed a total of .500" for width of idler gear and thickness of spacer may cause gear to bind tight enough to result in serious damage to pump.

Note: If scavenger idler gear has a groove on one side starting between two gear teeth and extending nearly to stud hole, install it on stud with grooved side against pump body. If scavenger idler gear has a groove across stud hole and in line with gear teeth, install it on stud with groove side outward. Parts order scavenger idler gear has both the grooves just mentioned, one on each side; is .497" wide and can be installed in any O.H.V. Model scavenger pump.

If pump is fitted with rear chain oiler, install scavenger pump gear (23) on drive shaft with groove (between two gear teeth) outward.

Lock rings (1) and (24) are often damaged when removing them, therefore, it is advisable to install new ones when reassembling and installing pump. Make sure lock ring is securely engaged and seated in retaining groove.

## Service Oil Pump (O.H.V. Engine)

(1940 Model)

With few exceptions, information under "Service Oil Pump" (O.H.V. Engine)—1941 to 1947 Models, Page 71, applies to 1940 Model oil pump. The exceptions are:

1. Pump does not incorporate governor rotor with automatic (centrifugal) by-pass valve.
2. Pressure regulating (by-pass) valve spring is not interchangeable with 1941 and later spring. Free length of new pressure regulating (by-pass) valve spring (15) is approximately 1-25/32".

## Service Oil Feed Pump (Side Valve Engine)

(1941 to 1947 Models)

(To Identify Items, Refer to Illus. 57)

Oil feed pump is of the vane type. Pump incorporates an automatic (centrifugal) by-pass valve, reducing oil feed supply at low engine speeds and increasing supply at high engine speeds. Pump is provided with two check valves (8) and (16) and adjustable pressure regulating valve (4). Maximum pressure is approximately 35 pounds per sq. in.

Thoroughly clean exterior of pump in gasoline or cleaning solvent before disassembling.

When disassembling oil feed pump, note location of all parts for correct reassembly.

Remove rotor (17) with vanes (19) and (20) and spring (18) from pump body (5) holding vanes to prevent expansion of spring and possible loss of parts.

Remove chamber cap screws (1), (6) and (14), adjusting screw (2), springs (3), (7) and (15) and valves (4), (8) and (16).

Clean all parts in gasoline or cleaning solvent and blow out all pump body passages with air.

Inspect rotor chamber closely for excessive wear caused by vanes. Pump body with badly worn rotor chamber should be replaced.

Inspect vane spring (18) for breakage and rusted condition. Free length of new spring is approximately 1-5/32". Replace if not in good condition. Vanes will usually be found in good condition, unless excessively worn by dirt taken into engine (rotor chamber would also be worn). Replace worn or damaged vanes.

Using a light, inspect valve seats in pump body for pits and for dirty condition. Note: A small particle of foreign matter lodged on valve seat will prevent valve from seating, thus preventing correct operation of pump. Replace pump body if seats are damaged.

Inspect springs for breakage and rusted condition. Replace if not in good condition. Free length of new pressure regulating (by-pass) valve spring (3) is approximately 2-1/16".

Check valve springs (7) and (15) are the same for all pumps, but are not interchangeable with any pressure regulating (by-pass) valve spring. It is much lighter (has less tension) than pressure regulating (by-pass) valve spring. Free length of new check valve spring is approximately 1-9/32".

Valves (4), (8) and (16) are interchangeable for check valve or pressure regulating (by-pass) valve and are the same for all pumps. Valves may have rings formed by action on valve seats. Valves not perfectly smooth and round should be replaced. Rotor and centrifugal by-pass valve assembly (17), and rotor chamber in pump body, ordinarily show no appreciable wear, and very seldom need replacing.

Make sure that all parts, and valve seats and all passages in pump body are thoroughly clean and free from dust, dirt, or grit before assembling. Also make sure valve in rotor (17) works freely, as a sticking valve will likely result in over-oiling at lower speeds.

Install the two check valves (8) and (16), springs (7) and (15) and secure with chamber cap screws (6) and (14). Install pressure regulating (by-pass) valve (4) and spring (3). Turn down adjusting screw (2) until end of screw is  $\frac{3}{8}$ " below top of pump body. This is normal setting. See "Adjusting Oil Feed Pump," Page 28. Install chamber cap screw (1).

Install spring (18) between rotor vanes (19) and (20) registering spring ends in holes in vanes and install rotor and vane assembly in pump body



ITEM	NUMBER USED	PART NUMBER	NAME	
1	1	6-36	FRONT CYLINDER	61" model - Standard bore 3.312" to 3.313". Oversize limit .070"
	1	7-36	REAR CYLINDER	
	1	6-41	FRONT CYLINDER	74" model - Standard bore 3.437" to 3.438". Oversize limit .070"
	1	7-41	REAR CYLINDER	
2	2	256-36A	PISTON - 61" model	Complete with Items 3, 4, 5, & 6. Oversize Pistons available .005", .010", .020", .030", .040", .050", .060", & .070" - .001" to .002" clearance in cylinder.
	2	256-41	PISTON - 74" model	
3	2	276-36	PISTON PIN - 61" model	Diameter .7915". Light hand press fit in Piston. .001" clearance in connecting Rod bushing. Oversize Pins available: .002", .004", .006", .008", .010", .012", & .015".
	2	276-32	PISTON PIN - 74" model	
4	2	280-32	PISTON PIN LOCK RING. Do not re-use Lock Rings after removing from Pins; replace with new.	
5	4 or 5	265-36	PISTON COMPRESSION RING - 61" model	
	4	265-41	PISTON COMPRESSION RING - 74" model	
6	4	265-41	PISTON OIL CONTROL RING (STANDARD TYPE) - 61" model	
	4	266-41	PISTON OIL CONTROL RING (STANDARD TYPE) - 61" model	
	2	263-40A	PISTON OIL CONTROL RING (SPECIAL TYPE) - 61" model	
	4	266-41A	PISTON OIL CONTROL RING (SPECIAL TYPE) - 61" model	

Fit with .010" to .020" gap; .004" side clearance in grooves. Oversizes same as piston, Item 2, except Oil Control Ring 263-40A and 266-41A have oversize limit of .040". Special and Standard Type Oil Control Rings not used together. For correct Piston Ring combinations, see "Piston Rings" Page 89

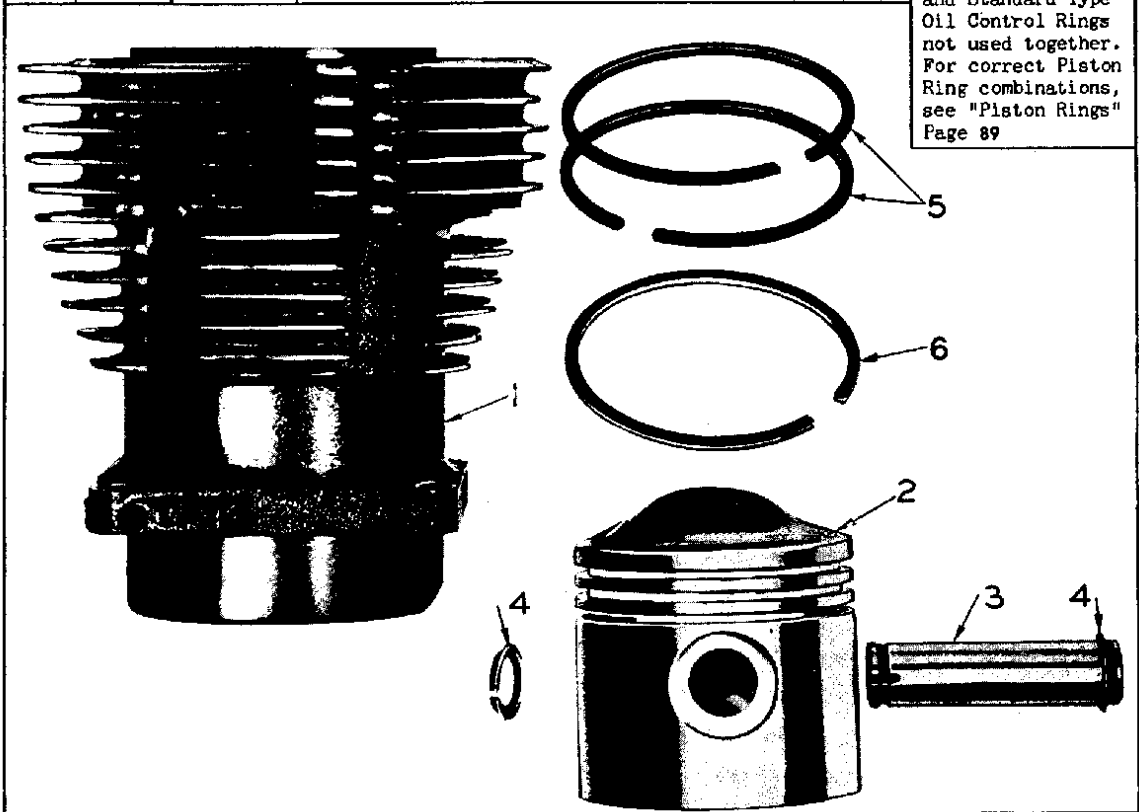

ILLUS. 60  
CYLINDER AND PISTON ASSEMBLY AND CHART (O.H.V. ENGINE)

After refitting Cylinder seat and Valve face, cut or grind additional clearance **HERE** as needed to allow perfect matching of top edges of Cylinder seat and Valve face when Valve is fully closed.

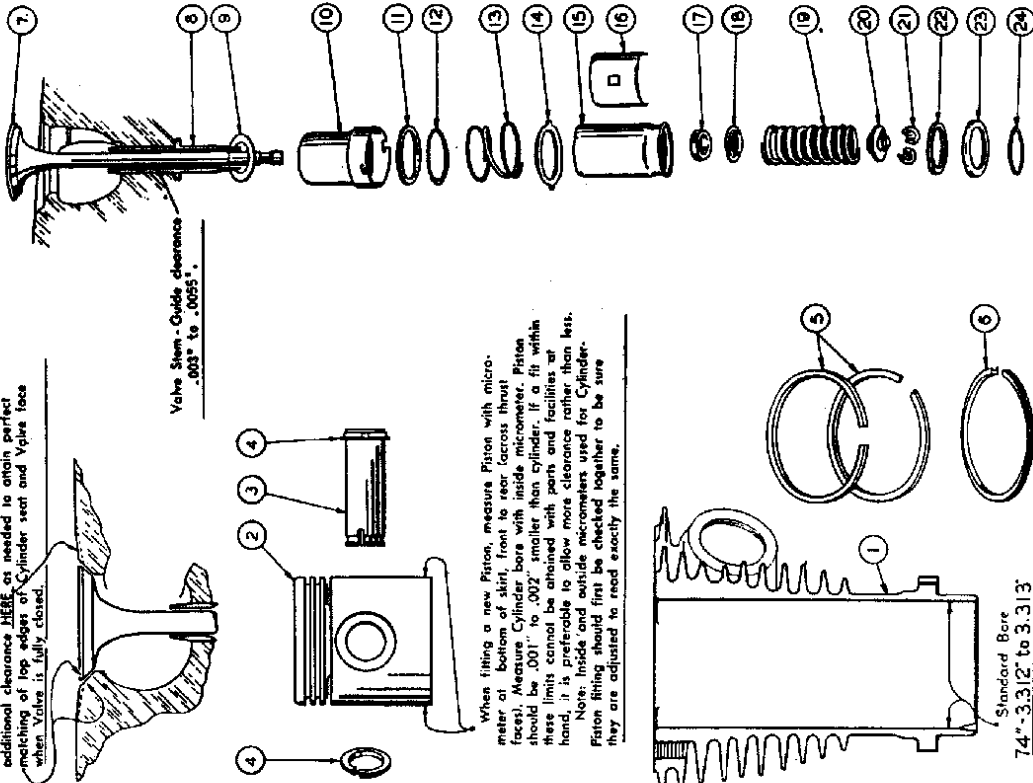

Valve Stem - Guide clearance  
.003" to .0055"

Standard Bore  
74"-3.312" to 3.313"  
80"-3.4215" to 3.4225"

ITEM	QUANTITY USED	PART NUMBER	NAME
4	4	4-37	FRONT CYLINDER 74" model - Standard bore 3.312" to 3.313" Oversize limit .070"
5	4	5-37	REAR CYLINDER 74" model - Standard bore 3.312" to 3.313" Oversize limit .070"
3	4	266-37	PISTON - 74" model Complete with items 3, 4, 5, 1, 6. Oversize Pistons available in .005", .010", .020", .030", .040", .050", .060" & .070" - .090" to .002" clearance in cylinder.
3	2	276-36	PISTON PIN - 74" model Diameter .7315". Light hand press fit in piston. .001" clearance in connecting rod. Minimum diameter .7315".
3	2	276-32	PISTON PIN - 74" model Diameter .7315". Light hand press fit in piston. .001" clearance in connecting rod. Minimum diameter .7315".
4	4	68-388	PISTON PIN LOCK RING (Do not reuse Lock Rings after removing from Pin; replace with new.)
5	4	171-38	PISTON COMPRESSION RING - 74" model Install three compression rings on front piston; two compression rings and one oil control ring on rear piston. Fit with .010" to .020" gap; oversize same as piston, Item 2.
5	4	172-38	PISTON COMPRESSION RING - 80" model
5	4	266-36	PISTON OIL CONTROL RING - 74" model
5	4	266-37	PISTON OIL CONTROL RING - 80" model
7	4	171-38	EXHAUST VALVE Intake and Exhaust Valves same dimensions but must not be interchanged. Head dia. 1.157/16"; face angle 45°; stem dia. .370" to .371"; clearance in gullet .003" to .0055".
7	4	163-37	INTAKE VALVE
8	4	66-30	VALVE GUIDE - Press fit in cylinder; .379" to .3755" Ream
10	4	106-30	SPRING COVER ASBESTOS GASKET
10	4	172-39	UPPER COVER
11	4	175-39A	CORK WASHER - Between Upper and Lower Covers.
18	4	176-39A	CORK WASHER RETAINER
3	4	175-39A	VALVE SPRING COLLAR SPACER
3	4	175-39L	VALVE SPRING COLLAR SPACER
18	4	174-39	LOWER COVER
18	4	175-39	KEEPER
22	4	172-39	VALVE SPRING COLLAR SPACER
18	4	170-30A	VALVE SPRING COLLAR (UPPER)
19	4	108-30B	VALVE SPRING - Free length approximately 4.7/16" 28 to 35 pounds @ 1-3/4".
20	4	171-30	VALVE SPRING COLLAR (LOWER)
21	4	172-30	SPLIT VALVE KEY (PAIR)
22	4	175-39A	LOWER COVER CORK WASHER
18	4	175-39B	CORK WASHER RETAINER
20	4	175-39C	RETAINER SEAT ASBESTOS

## 74" & 80" SIDE VALVE ENGINE UPPER END ASSEMBLY

ILLUS. 61

1940 AND LATER

O.H.V. 61 AND 74 V TYPE ENGINE BASE ASSEMBLY

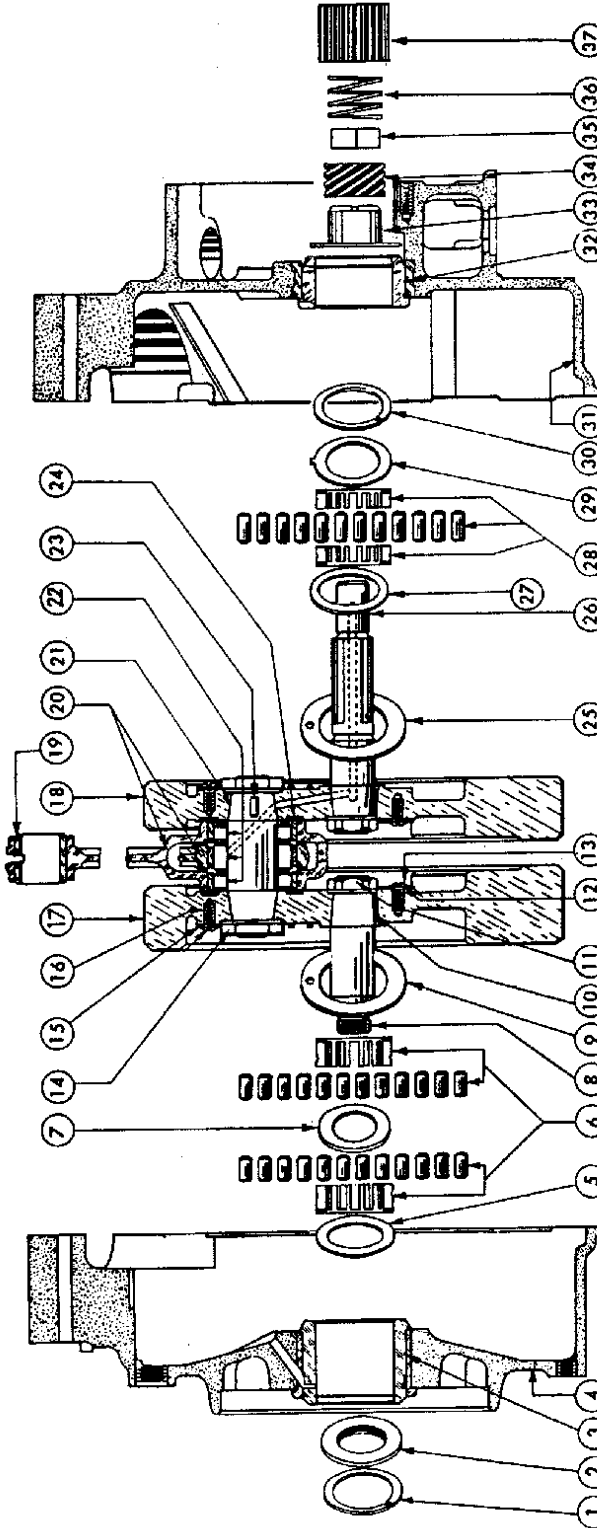

ITEM NUMBER	1940-41 PART NUMBER	1941 AND LATER PART NUMBER	1941 AND LATER PART NUMBER	1941 AND LATER PART NUMBER	DESCRIPTION
1	423-40	423-40	423-40	423-40	BEARING SPRING RING — (Same as item 30)
2	421-40	421-40	421-40	421-40	OIL RETAINING BUSHING — (Same as item 30)
3	415-40	415-40	415-40	415-40	LEFT FLYWHEEL — NOTE: When only one-half case is damaged and left case is good, use both halves. — FOOTNOTE NO. 2
4	402-40	402-41	402-41	402-41	RIGHT FLYWHEEL — NOTE: When only one-half case is damaged and right case is good, use both halves. — FOOTNOTE NO. 2
5	422-40	422-40	422-40	422-40	1940-41 OHV, left case is No. 406-40A and right case is No. 406-41 and right case is No. 410-41
6	417-33	419-30	419-30	419-30	SHOCKET SHAFT BEARING WASHER — (Same as item 23)
7	358-16	358-16	358-16	358-16	SHOCKET SHAFT ROLLER BEARING — (Same as item 23)
8	352-30	352-30	352-30	352-30	SHOCKET SHAFT ROLLER BEARING WASHER — (Same as item 23)
9	358-17	358-17	358-17	358-17	SHOCKET SHAFT ROLLER BEARING WASHER — (Same as item 23)
10	361-17	361-17	361-17	361-17	FLYWHEEL THAUST COLLAR — 0.045" to 0.102" in steps of .004"
11	362-36	364-36	364-36	364-36	SHAFT KEY
12	370-36	370-36	370-36	370-36	SHAFT ROLLER BEARING COMPLETE — (Same as item 23)
13	030	030	030	030	CRANK PIN AND SHAFT NUT LOCK WASHER
14	365-16	365-16	365-16	365-16	SPROCKET SHAFT AND GEAR SHAFT NUT LOCK WASHER
15	369-41	369-41	369-41	369-41	CRANK PIN NUT LOCK WASHER — (Same as item 12)
16	001	001	001	001	CRANK PIN NUT LOCK WASHER — (Same as item 12)
17	002	002	002	002	CRANK PIN NUT LOCK WASHER — (Same as item 12)
18	003	003	003	003	CRANK PIN NUT LOCK WASHER — (Same as item 12)
19	004	004	004	004	CRANK PIN NUT LOCK WASHER — (Same as item 12)
20	005	005	005	005	CRANK PIN NUT LOCK WASHER — (Same as item 12)
21	006	006	006	006	CRANK PIN NUT LOCK WASHER — (Same as item 12)
22	007	007	007	007	CRANK PIN NUT LOCK WASHER — (Same as item 12)
23	008	008	008	008	CRANK PIN NUT LOCK WASHER — (Same as item 12)
24	009	009	009	009	CRANK PIN NUT LOCK WASHER — (Same as item 12)
25	010	010	010	010	CRANK PIN NUT LOCK WASHER — (Same as item 12)
26	011	011	011	011	CRANK PIN NUT LOCK WASHER — (Same as item 12)
27	012	012	012	012	CRANK PIN NUT LOCK WASHER — (Same as item 12)
28	013	013	013	013	CRANK PIN NUT LOCK WASHER — (Same as item 12)
29	014	014	014	014	CRANK PIN NUT LOCK WASHER — (Same as item 12)
30	015	015	015	015	CRANK PIN NUT LOCK WASHER — (Same as item 12)
31	016	016	016	016	CRANK PIN NUT LOCK WASHER — (Same as item 12)
32	017	017	017	017	CRANK PIN NUT LOCK WASHER — (Same as item 12)
33	018	018	018	018	CRANK PIN NUT LOCK WASHER — (Same as item 12)
34	019	019	019	019	CRANK PIN NUT LOCK WASHER — (Same as item 12)
35	020	020	020	020	CRANK PIN NUT LOCK WASHER — (Same as item 12)
36	021	021	021	021	CRANK PIN NUT LOCK WASHER — (Same as item 12)
37	022	022	022	022	CRANK PIN NUT LOCK WASHER — (Same as item 12)



1940 AND LATER

SIDE VALVE 74 AND 80 V TYPE ENGINE BASE ASSEMBLY

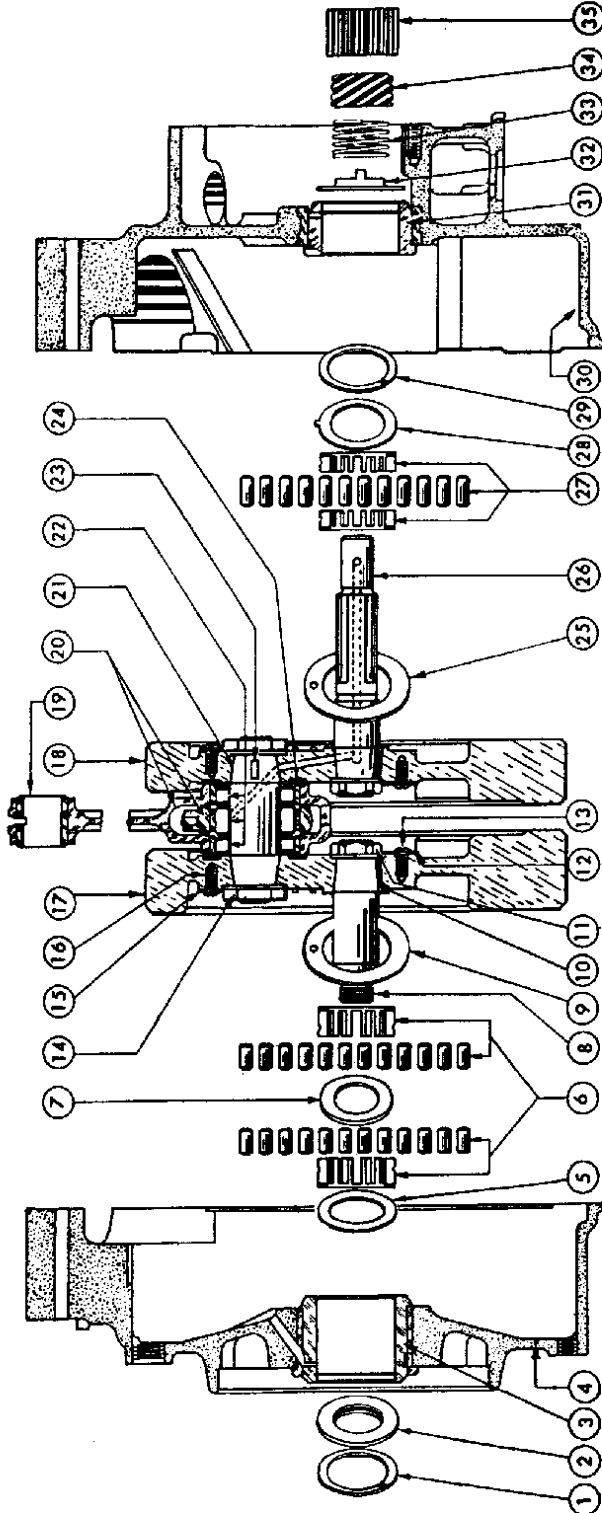

ITEM NUMBER	PART NUMBER	QUANTITY	DESCRIPTION
1	423-40	2	BEARING SPRING RING — (Same as item 29).
2	421-40	1	OIL BEARING BUSHING — Press fit in item 3.
3	418-40	1	LEFT CRANK CASE ROLLER BEARING BUSHING — .0023" Press fit in case.
4	403-37	1	SET OF CRANK CASES — NOTE: When only one-half case is damaged and needs to be replaced, return good half to the factory to be properly matched with a new half case. Left case is No. 406-37 and right case is No. 410-37.
5	419-30	1	SPROCKET SHAFT ROLLER BEARING COMPLETE — Fit this bearing .0005" to .001" loose. Bearing consists of 2 No. 417-30 retainers and 24 No. 2289-25 rollers. [See FOOTNOTE NO. 2.]
6	419-30	1	SPROCKET SHAFT ROLLER BEARING COMPLETE — Fit this bearing .0005" to .001" loose. Bearing consists of 2 No. 417-30 retainers and 24 No. 2289-25 rollers. [See FOOTNOTE NO. 2.]
7	358-36	1	SPROCKET SHAFT
8	352-30	1	SPROCKET THROST COILAR — .065" to .102" in steps of .004". (Same as item 23).
9	358-17	2	FLYWHEEL
10	361-12	2	SHAFT KEY
11	364-36	2	SPROCKET SHAFT AND GEAR SHAFT NUT
12	370-36	4	CRANK PIN AND SHAFT NUT LOCK WASHER — (Same as item 15).
13	030	4	LOCK WASHER SCREW — (Same as item 16).
14	368-36	2	CRANK PIN NUT
15	(See item 12)		
16	(See item 13)		
17	340-37	1	LEFT FLYWHEEL — When assembled, allow .012" to .014" end play in crankcases.
18	341-37	1	RIGHT FLYWHEEL — Adjust end play with collars, items 9 and 23. FOOTNOTE NO. 1 — Referring to item 22; Diameter of standard roller is .1875". Complete bearings are available with rollers from standard to .001" oversize in steps of .0002". FOOTNOTE NO. 2 — Referring to items 6 and 28; Diameter of standard roller is .750". Complete bearings are available with rollers from .001" undersize to .001" oversize in steps of .0002".
19	292-36	2	PISTON PIN BUSHING — Bore of hole to fit piston pin .001" loose.
20	290-37	1	SET OF CONNECTING RODS, with crank pin and roller bearing complete (includes items 14, 21 and 22). Forked (rear) rod side play .006" to .010" between flywheel washers, (item 24). Forked (rear) rod is No. 285-37 and single end (front) rod is No. 286-37.
21	348-40	1	CRANK PIN
22	309-40	1	CRANK PIN ROLLER BEARING COMPLETE — Fit this bearing .001" to .0012" loose. Bearing consists of 4 No. 301-40 retainers, 18 No. 305-40 long rollers, and 24 No. 302-40 short rollers. [See FOOTNOTE NO. 1.]
23	1650-18	1	CRANK PIN KEY
24	372-36	2	FLYWHEEL STEEL WASHER
25	(See item 9)		
26	414-36	1	GEAR SHAFT
27	356-37	1	GEAR SHAFT ROLLER BEARING COMPLETE — Fit this bearing .0008" to .0012" loose. Bearing consists of 2 No. 415-36 retainers and 12 No. 209-26 rollers. [See FOOTNOTE NO. 2.]
28	414-40	1	GEAR SHAFT BEARING WASHER
29	(See item 1)		
30	413-40	1	RIGHT CRANKCASE ROLLER BEARING BUSHING — .0023" Press fit in case.
31	352-40	1	GEAR SHAFT BEARING OIL SEAL RING
32	356-37	1	BEARING OIL SEAL RING SPRING
33	687-37	1	SEAL RING
34	604-37	1	PISTON VALVE & SCRAPPER PUMP PINION SHAFT GEAR (SPIRAL GEAR)
35	604-37	1	PISTON VALVE & SCRAPPER PUMP PINION SHAFT GEAR (SPIRAL GEAR)

## Installing Timing Gears (O.H.V. Engine)

Before installing timing gears, install on pinion gear shaft in the following order: oil pump drive gear (34), spacing collar (35), spring (36) and pinion gear (37) as shown in Illus. 62.

Install the .050" thick steel thrust washer on inner end of cam gear shaft. Install timing gears (2) and (4) and breather valve (3) in gear case with marks in alignment, including the two marks on pinion gear, as shown in Illus. 64. Install spacer and split lock ring on circuit breaker drive gear stud. Install breather screen and screen separator in breather pocket in crankcase, with separator above as shown in Illus. 64, and scalloped edge of separator inward against crankcase.

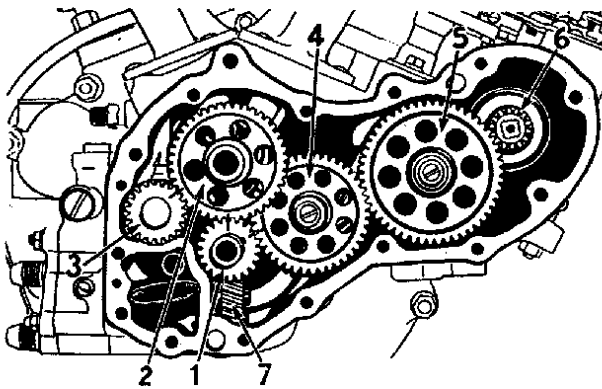

ILLUS. 64

### TIMING GEARS WITH MARKS IN CORRECT ALIGNMENT (O.H.V. ENGINE)

1. Pinion gear. Gear and shaft are spline engaged and gear is a slip fit on shaft.
2. Cam gear. (Steel spacing washer behind this gear).
3. Breather gear.
4. Circuit breaker drive gear. (Spacing collar in front of this gear).
5. Intermediate gear (not marked). (Spacing collar in front of this gear).
6. Generator drive gear (not marked).
7. Oil pump drive gear (not marked); secured on end of pump drive shaft with key and spring ring.

## Installing Timing Gear Case Cover (O.H.V. Engine)

Before installing cover, lay engine on its side and pour about  $\frac{1}{4}$  pint of engine oil over timing gears.

Unless gear case cover gasket is in good condition, install a new "factory-made" gasket. Never use a "home-made" gasket as this gasket has holes especially located for oil passages and if a hole is left out or put in wrong place oiling system will not function normally. Install cover and all gear case cover screws. Tighten screws securely, and turn engine and note whether or not it turns freely. If new cam gear shaft bushings were installed and considerable drag is felt, it is very likely that the cam gear thrust washer may be too thick and must be ground thinner, to give cam gear from "free running" to

.005" endplay. Check endplay of cam gear with a thickness gauge, through tappet guide hole.

After correct endplay has been established, install tappets and tappet guides. See "Valve Tappets and Valve Tappet Guides," Page 58.

## Installing Timing Gears (Side Valve Engine)

Install timing gears in case with marks in alignment, including mark on pinion gear as shown in Illus. 65. These gears are ordinarily assembled with one steel shim washer behind each of the four cam gears and one shim washer in front of the two front cylinder cam gears. Occasionally an engine may be found that was originally assembled with more shim washers or without shim washers at one or more points. In this case, reassemble with the same number of washers found when disassembling.

## Installing Timing Gear Case Cover (Side Valve Engine)

Before installing cover, lay engine on its side and pour about  $\frac{1}{4}$  pint of engine oil over timing gears.

Unless gear case cover gasket is in good condition, install a new "factory-made" gasket. Never use a "home-made" gasket as this gasket has holes especially located for oil passages and if a hole is left out or put in wrong place, oiling system will not function normally.

Install cover and all gear case cover screws, except hexagon-head bolt which also holds oil feed pump. Tighten screws securely (this includes generator screws), and turn engine and note whether

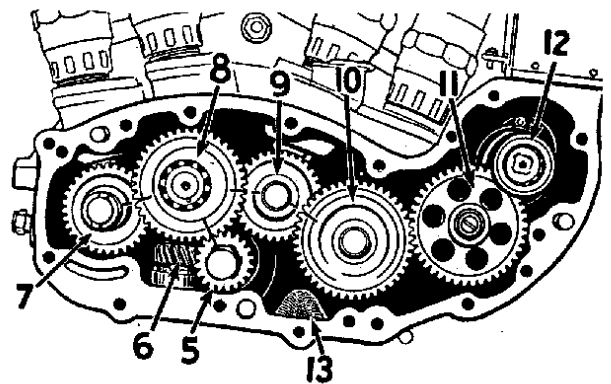

ILLUS. 65

### TIMING GEARS WITH MARKS IN CORRECT ALIGNMENT (SIDE VALVE ENGINE)

5. Pinion gear. Gear and shaft are spline engaged and gear is a slip fit on shaft.
6. Crankcase breather sleeve gear; also drives scavenger oil pump.
7. Rear exhaust cam gear; also drives oil feed pump.
8. Rear intake cam gear; also drives ignition circuit breaker.
9. Front intake cam gear.
10. Front exhaust cam gear.
11. Intermediate gear (not marked).
12. Generator drive gear with centrifuge (not marked).
13. Oil screen.

or not it turns freely. If considerable drag is felt, possibly, too many steel shim washers have been installed to one or more cam gear shafts. In this case make necessary correction. Cam gear should be from "free running" to .007" endplay. Check endplay of each cam gear with a thickness gauge, through tappet guide hole.

After correct endplay has been established, install tappets and tappet guides. See "Valve Tappets and Valve Tappet Guides," Page 58.

### Installing Oil Feed Pump (Side Valve Engine)

Illus. 21 shows oil pump in position to be installed.

Examine gasket closely. If oil feed pump gasket is in good condition it can be reused. If condition of gasket is at all questionable, install a new "factory-made" gasket. Never use a "home-made" gasket because this gasket has holes especially located for oil passages and if hole is left out or put in wrong place, oiling system may be put completely out of commission.

Start pump onto its three mounting studs, turn engine slowly and press lightly against pump until driving dogs on cam gear shaft line up with and drop into driving slot in oil pump rotor. Install hexagon-head screw and lock washer and install the three lock washers and nuts on pump mounting studs and tighten all securely. Note that two of these nuts are long extension nuts. These special nuts must be installed on same studs from which they were originally removed to give wrench clearance.

### Ignition Circuit Breaker and Flywheel Timing Mark

(Refer to Illus. 66 or 67)

1. Flywheel timing mark: *O.H.V. Engine*, at rear edge of inspection hole in left crankcase, see Illus. 66; *Side Valve Engine*, slightly forward of center of inspection hole in left crankcase, see Illus. 67.  
Arrow indicates direction in which engine runs.
2. Adjustable contact point lock screws. Loosen these screws to adjust point gap.
3. Contact point gap. Gap fully open (breaker lever fibre on highest point of cam) should be .022". Wrong gap affects time of ignition. See "Servicing Circuit Breaker and Base Assembly," Page 80.
4. *1946 and Earlier Models*: mark on breaker cam (registers with breaker lever fibre) and mark on circuit breaker head, and hole in adjusting band, indicates original factory timing.  
*1947 Models*: mark on breaker cam (registers with breaker lever fibre), and mark on circuit breaker head aligned with outer edge of timing adjusting stud plate indicates original factory timing. (Not illustrated.)
5. Breaker cam. Narrow cam times front cylinder; wide cam times rear cylinder. Cam should be lubricated occasionally with a very light application of grease.
6. Condenser.
7. *1946 and Earlier Models*: Adjusting band screw: After loosening this screw and thus loosening adjusting band, circuit breaker head can be shifted to adjust timing.  
*1947 Models*: After loosening timing stud lock nut, circuit breaker head can be shifted to adjust timing. (Not illustrated.)
8. *1946 and Earlier Models*: Advance and retard lever; counter-clockwise position is advanced clockwise position is retarded.  
*1947 Models*: Advance and retard lever not used. Timing adjusting stud controls movement of circuit breaker head; counter-clockwise position is advanced clockwise position is retarded. (Not illustrated.)
9. *O.H.V. Models*: Cap screws (two) that secure circuit breaker assembly in crankcase.

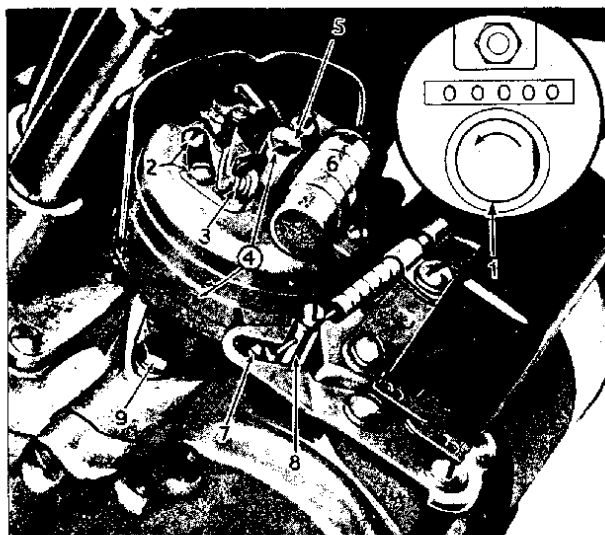

ILLUS. 66  
IGNITION CIRCUIT BREAKER (O.H.V. ENGINE)

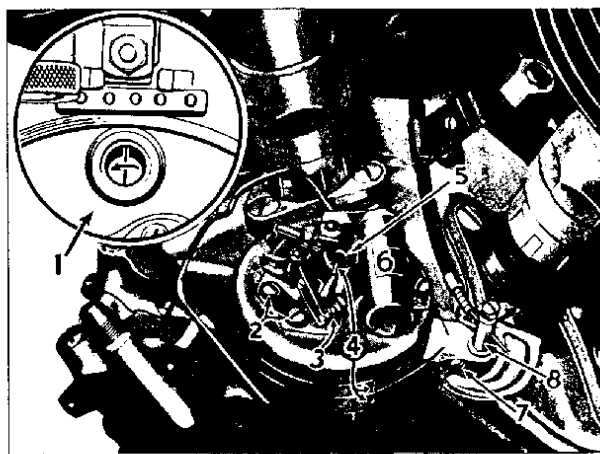

ILLUS. 67  
IGNITION CIRCUIT BREAKER (SIDE VALVE ENGINE)

## Servicing Circuit Breaker and Base Assembly

(Refer to Illus. 68 and 69)

Note: 1946 and earlier model circuit breaker shown in Illus. 68 and 69 differs from 1947 model circuit breaker only as regards advance and retard lever. See paragraph 8, under "Ignition Circuit Breaker and Fly-wheel Timing Mark," Page 79.

Circuit breaker base can be disassembled for replacement of base, circuit breaker shaft and circuit breaker shaft gear.

Circuit breaker head mounts the circuit breaker lever, adjustable contact point and condenser which are readily accessible (on or off motorcycle) for adjustment and for replacement when circuit breaker cover is removed.

To disassemble base, remove the pin from gear and drift or press circuit breaker cam shaft out of gear. Withdraw shaft from base. A steel spacer washer is located between gear and base stem.

To disassemble circuit breaker head, remove nuts from condenser and terminal binding post to free the brass terminal strip. Remove breaker lever spring and lift breaker lever from its insulated pivot stud. Remove the two lock screws and plate, and adjustable contact point assembly is then free for removal. Remove condenser mounting screw and washer—this screw also grounds condenser to circuit breaker head.

If inspection shows it to be necessary to replace the low tension wire (coil to circuit breaker) simply remove terminal nut and washer and remove wire.

Unless inspection shows circuit breaker head insulated terminal is in bad condition or insulation is defective it is not necessary to remove this part.

Clean all parts and inspect for good condition and signs of wear. The circuit breaker lever pivot stud insulation should be inspected and if found broken or cracked, replace circuit breaker head. The condenser may be tested on a condenser tester, although actual operation on engine is the surest, most dependable test.

Try circuit breaker head on base for a free turning, but not loose fit. If head has too much clearance on base, the circuit breaker point gap will vary as the head is shifted for spark control.

Replace any worn and/or damaged parts that will affect operation of circuit breaker as a whole.

Reassemble in reverse order of disassembly. When assembling circuit breaker shaft in circuit breaker base, select a steel washer (between shaft gear and base) that will give a free running fit to .008" endplay. Endplay in excess of .008" will affect ignition timing. Secure shaft gear to shaft with new steel pin riveted in place.

O.H.V. Models: When assembling circuit breaker complete for installation, make sure that low tension wire is allowed enough slack within circuit breaker head to be free for full advance and retard movement.

All Models: Circuit breaker points that are burned or pitted should be renewed or dressed with a clean fine-cut contact point file. The file should not be used on other metals and should not be allowed to become greasy or dirty. Never use emery cloth to clean points. Contact surfaces, after considerable use, may not appear bright and smooth; but this is not necessarily an indication that they are not functioning satisfactorily.

Point faces must seat squarely against each other. If bent, square up by bending contact plate.

Point gap with breaker lever fibre on highest point of cam, should be .022". Wrong cap affects ignition timing. Adjust by loosening the two lock screws and shifting adjustable contact plate. Measure gap with accurate thickness gauge before retightening lock screws and recheck gap after tightening lock screws. Note: Final checking and readjusting of point gap must be made after circuit breaker head is installed on base. See "Installing Circuit Breaker and Timing Ignition (O.H.V. Engine)", Page 81, or

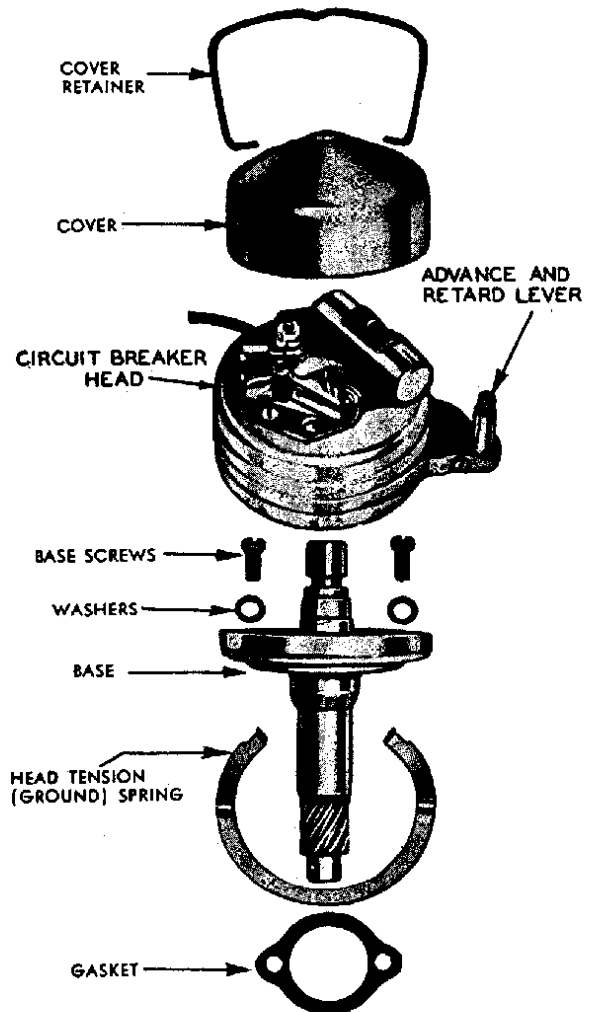

ILLUS. 68  
CIRCUIT BREAKER DISASSEMBLED

"Installing Circuit Breaker and Timing Ignition (Side Valve Engine)," Page 82.

Circuit breaker spring tension should be 13 to 15 oz. at points. Hook a spring scale on circuit breaker lever at contact point and pull to separate points.

Take reading of scale just as points separate.

If tension is too low, engine will miss at high speed—if tension is too high, breaker lever fibre will wear excessively.

Keep breaker cam very lightly greased.

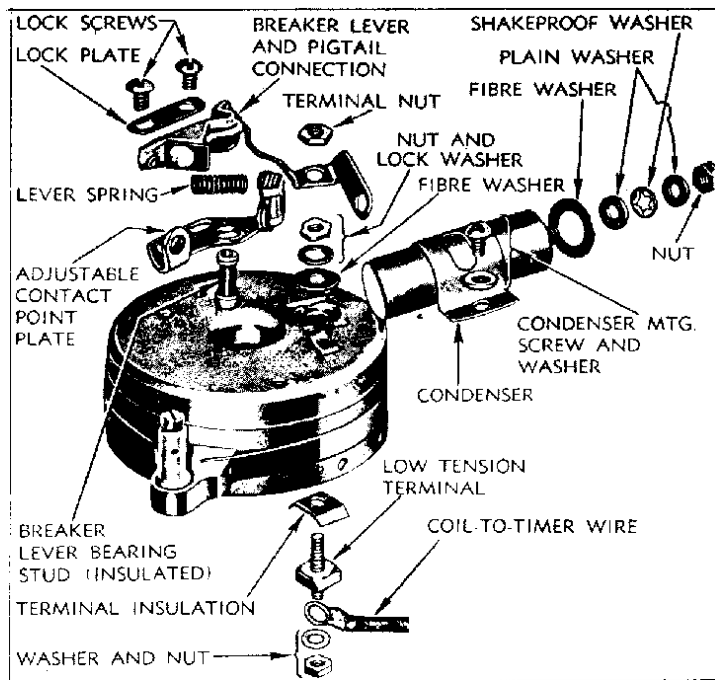

ILLUS. 69  
CIRCUIT BREAKER HEAD DISASSEMBLED

### Installing Circuit Breaker and Timing Ignition (O.H.V. Engine)

(1946 and Earlier Models)

Refer to Illus. 66—also see "Timing Ignition By Piston Position," Page 86.

Turn engine in direction in which it runs until tappets indicate front cylinder is on compression stroke (directly after front intake valve closes). Continue turning engine slowly until flywheel timing mark is at rear edge of inspection hole in left crankcase.

If front cylinder head is off—circuit breaker completely assembled, can be installed. Be sure ground spring is in its proper place so when cover retainer ends are inserted through holes in circuit breaker head, they also register in spring locating notches. Otherwise, spring will have no tension and the head will be loose on its base. Contact points and condenser are grounded through circuit breaker base and this spring holds the head in close contact with base, thus insuring a good ground.

First make sure mark (4) on circuit breaker head and hole (4) in circuit breaker adjusting band line up before installing circuit breaker.

Turn circuit breaker shaft counter-clockwise (to left) approximately 60° from position where mark (4)

on breaker cam lines up with fibre block on breaker lever.

Install base gasket and circuit breaker assembly, inserting shaft and shaft gear all the way down into place in gear case, with base turned so low tension wire is toward left side of engine and circuit breaker base mounting screw holes line up with holes in crankcase but do not as yet install base mounting screws.

Hold relay bracket on crankcase temporarily so mounting holes in bracket line up with holes in crankcase and stud in advance and retard lever registers in slot in bracket.

Fully advance lever (8) (turn counter-clockwise) and with relay bracket held in position, observe how closely mark (4) on breaker cam lines up with lever fibre.

If it does not line up, lift circuit breaker base and turn shaft gear so its engagement with its driving gear is changed one tooth. Check again according to breaker cam mark. Repeat this procedure until gear engagement is attained which closely aligns mark (4) and breaker lever fibre. When this has been accomplished, secure base and relay bracket with screws and lock washers.

Provided circuit breaker cam shaft gear has not been replaced and mark (4) on side of circuit breaker head and hole (4) in adjusting band are still in align-



ment, and breaker point gap is correctly adjusted, engine is now timed according to original factory setting. See "Recommended Recheck of Ignition Timing," Page 83.

If front cylinder head is on—circuit breaker must be disassembled before it can be installed.

First make sure mark (4) on circuit breaker head and hole in circuit breaker adjusting band line up.

Install gasket and circuit breaker head tension (ground) spring on circuit breaker base assembly and insert shaft and shaft gear all the way down into place in timing gear case, trying to locate mark on small end of breaker cam in position shown in Illus. 66. Do not as yet install base mounting screws.

Install circuit breaker head and hold relay bracket on crankcase temporarily so mounting holes in bracket line up with holes in crankcase, and stud in advance and retard lever (8) registers in slot in relay bracket. Do not install cover retainer until later.

Fully advance lever (8) (turn counter-clockwise) and with relay bracket held in position, observe how closely mark (4) on breaker cam lines up with breaker lever fibre.

If it does not line up, lift circuit breaker base and turn shaft gear so its engagement with its driving gear is changed one tooth. Check again according to breaker cam mark. Repeat this procedure until gear engagement is attained which closely aligns mark (4) and breaker lever fibre. When this has been accomplished, make sure base is turned so ignition coil wire is toward left side of engine and secure base and relay bracket with screws and lock washers.

Make sure that low tension wire is allowed enough slack within circuit breaker head to be free for full advance and retard movement.

Install head on base and secure with ground spring and cover retainer. Be sure ground spring is in its proper place so when cover retainer ends are inserted through holes in circuit breaker head, they also fit into spring locating notches. Otherwise, spring will have no tension and the head will be loose on its base. Contact points and condenser are grounded through circuit breaker base and this spring holds the head in close contact with base, thus insuring a good ground.

Provided circuit breaker cam shaft gear has not been replaced and mark (4) on side of circuit breaker head and hole (4) in adjusting band are still in alignment, and breaker point gap is correctly adjusted, engine is now timed according to original factory setting. See "Recommended Recheck of Ignition Timing," Page 83.

### **Installing Circuit Breaker and Timing Ignition (Side Valve Engine)**

(1946 and Earlier Models)

Refer to Illus. 67—also see "Timing Ignition By Piston Position," Page 86.

Turn engine in direction which it runs until tappets indicate front cylinder is on compression stroke (directly after front intake valve closes). Continue turning engine slowly until flywheel timing mark is slightly forward of center of inspection hole in left crankcase.

First make sure mark (4) on circuit breaker head and hole in circuit breaker adjusting band line up before installing circuit breaker.

Install base gasket and circuit breaker head tension (ground) spring on circuit breaker base assembly and insert shaft and shaft gear all the way down into place in timing gear case cover trying to locate mark on small end of breaker cam in position shown in Illus. 67. Do not as yet install base mounting screws.

Install circuit breaker head on base with control lever (8) within advance and retard quadrant as shown. Do not install cover retainer until later. Fully advance lever (8) (turn counter-clockwise) and observe how closely mark (4) on breaker cam lines up with breaker lever fibre. If it does not line up, lift circuit breaker base and turn shaft gear so its engagement with its driving gear is changed one tooth. Check again according to breaker cam mark. Repeat this procedure until gear engagement is attained which closely aligns mark (4) and breaker lever fibre. When this has been accomplished, make sure base is turned so low tension wire is toward rear of engine and secure base with screws and lock washers.

Make sure low tension wire is allowed enough slack within circuit breaker head to be free for full advance and retard movement.

Install head on base and secure with ground spring and cover retainer. Be sure ground spring is in its proper place so when cover retainer ends are inserted through holes in circuit breaker head, they also register into spring locating notches. Otherwise, spring will have no tension and the head will be loose on its base. Contact points and condenser are grounded through circuit breaker base and this spring holds the head in close contact with base, thus insuring a good ground.

Provided circuit breaker cam shaft gear has not been replaced and mark (4) on side of circuit breaker head and hole (4) in adjusting band are still in alignment, and breaker point gap is correctly adjusted, engine is now timed according to original factory setting. See "Recommended Recheck of Ignition Timing," Page 83.

### **Installing Circuit Breaker and Timing Ignition**

(1947 Models)

Information under "Installing Circuit Breaker and Timing Ignition (O.H.V. Engine)," 1946 and Earlier Models, Page 81, and "Installing Circuit Breaker and Timing Ignition (Side Valve Engine)," 1946 and Earlier Models, applies to respective 1947 Models except as follows:

1. A timing adjusting stud (also serves as advance and retard lever) replaces the adjusting band and advance and retard lever used formerly.

2. Circuit breaker base assembly is installed with timing stud slot facing forward. The slot governs maximum advance and retard.
3. Provided outer edge of timing adjusting stud plate is still in alignment with mark on side of circuit breaker head, breaker point gap is correctly adjusted and circuit breaker assembly is installed as described for 1946 and earlier Models (except as mentioned above), engine is now timed according to original factory setting.

## Recommended Recheck of Ignition Timing

(1946 and Earlier Models)

(Refer to Illus. 66 or 67)

Even though all marks are in perfect alignment, same as engine was originally timed, timing may change somewhat after engine has been in service for a time, due to normal wear and seating of the various parts that affect timing.

If circuit breaker cam shaft gear was replaced, there is a possibility that timing may be off considerably with original factory marks in alignment. Shaft gear pin hole is not drilled in any definite relation to gear teeth, and therefore, if a gear is installed in which the pin hole is drilled in a different location from that in original gear, circuit breaker head must be shifted as necessary (disregard original factory mark (4) on circuit breaker head) to correct ignition timing.

Since accurate ignition timing is the first essential to good engine performance, it is advisable, after ignition has been timed according to marks as explained above, to recheck as follows:

See that circuit breaker points are adjusted for correct gap of .022". Advance breaker lever (8) fully. Turn engine in direction in which it runs until front cylinder is on compression stroke and continue to turn it ahead slowly until narrow cam (the one with timing mark), just starts to open breaker points.

An accurate check as to when points just start to open can be made with a test lamp as follows:

If engine is installed in chassis, connect one wire of test lamp to coil rear terminal along with low tension (circuit breaker) wire; connect other wire to ground and turn ignition switch "ON." As long as points are closed, lamp will remain out; as points start to open, lamp will light.

When exact position is found, where points just start to open, flywheel mark should be at rear edge of inspection hole for O.H.V. Engine—see Illus. 66, or slightly forward of center of inspection hole for Side Valve Engine—see Illus. 67. If mark is not in proper location, adjust timing as necessary by loosening screw (7) which loosens adjusting band, and shift circuit breaker head in band.

If flywheel timing mark is forward of rear edge of inspection hole—O.H.V. Engine, or more than slightly ahead of center in hole—Side Valve Engine, timing is late. To correct, shift circuit breaker head against rotation (counter-clockwise) of breaker cam.

If flywheel timing mark is to rear of inspection hole and not visible—O.H.V. Engine, or in center of

hole—Side Valve Engine, timing is early. To correct, shift circuit breaker head with rotation (clockwise) of breaker cam.

With ignition timing correct, front piston is 7/16" —O.H.V. Engine, or 11/32"—Side Valve Engine, before top center, on compression stroke, when points just start to open. At this point, spark occurs, igniting front cylinder fuel charge.

Ignition timing should be checked in this manner every 2000 miles.

## Recommended Recheck of Ignition Timing

(1947 Models)

Information under "Recommended Recheck of Ignition Timing," 1946 and Earlier Models, applies to respective 1947 Models except as follows:

If flywheel mark is not in proper location when points just start to open, readjust timing as necessary by loosening timing adjusting stud lock nut and shifting circuit breaker head as necessary.

## Installing Pistons

It is assumed that piston-cylinder fitting, also pin and ring fitting have already been given due attention as per information under "Refinishing Cylinders Oversize and Fitting New Pistons," Page 45, "Emergency Piston and Ring Service," Page 87, and "Piston Rings," Page 89. Whether new or used pistons are being installed, the rings should be new. It is not practical to reassemble an engine with used rings, even though rings may not be very badly worn.

Install pistons according to instructions under "Piston and Pin," Page 88. Handle pistons carefully so they will not be burred, cracked or otherwise damaged.

## Aligning Connecting Rods

In refitting and reassembling connecting rods, and finally fitting pistons, rods may possibly be bent or twisted, throwing upper bearing and lower bearing out of alignment with each other to some extent. Therefore, after pistons have been installed, rods must be checked and re-aligned as may be necessary. If a rod is left bent, or twisted, piston has a "cocked" relation to cylinder bore and the result is excessive noise and rapid wear.

Check rod alignment by means of piston squaring plate (Harley-Davidson special squaring plate, Part No. 11919-X), as shown in Illus. 70. Be sure crankcase face is clean and free from burrs so that squaring plate seats fully. Note: 74" O.H.V. piston skirt is cut away at bottom (below piston pin) for flywheel clearance, therefore, it cannot be used with squaring plate for checking rod alignment. Temporarily install and use a 61" O.H.V. or Side Valve Engine piston to check 74" O.H.V. rod alignment.

If a rod is in perfect alignment, piston bottom will rest squarely on plate with flywheels turned so that crank pin is in either forward or rear position. Bear in mind that this check, to be accurate, depends upon

checking with crank pin in both forward and rear positions, as it is the change of rod angle, resulting from changing crank pin from one position to the other, that influences the seating of piston on squaring plate and thus indicates whether or not rod is in alignment.

Rather than depend entirely upon visual check, as to when piston seats squarely upon plate, insert narrow strips of paper of equal thickness underneath piston, one on each side, below piston pin, as shown in Illus. 70. Press piston down lightly with finger tips resting on center of piston head and pull first one paper, then the other, partially from underneath piston. If piston is perfectly square (rod in alignment), both will have the same amount of drag.

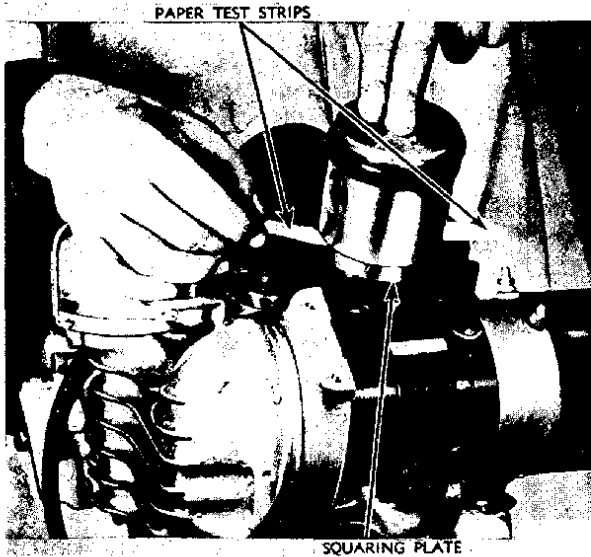

ILLUS. 70  
CHECKING CONNECTING ROD ALIGNMENT WITH  
SQUARING PLATE

If rod proves to be out of alignment, it can be straightened by means of a bar inserted through piston pin, as shown in Illus. 71. Use bar of largest diameter that can be inserted through pin.

The manner in which piston seats on squaring plate indicates as follows:

1. Piston high on same side, both crank pin positions; rod is bent.
2. Piston high on opposite sides as crank pin position is changed; rod is twisted.
3. Piston square or nearly square with crank pin in one position and high on one side with crank pin in other position; rod is bent and twisted.
4. To straighten a bent rod, insert straightening bar through piston pin hole on low side of piston and apply upward force.
5. To straighten a twisted rod, insert straightening bar through piston pin hole on high side of piston, and if crank pin position is to front apply force to rear—if crank pin position is to rear apply force to front.

6. To straighten a bent and twisted rod (combination of a bend and twist) remove bend first and then remove twist. See above paragraphs, Nos. 4 and 5.

After rods have been aligned check to see that pistons center in crankcase cylinder opening, without side pressure on upper rod ends. If further re-aligning is necessary to center pistons, correct by one of the following methods: Dress off end of rod upper bushing (on interfering side) with a file; install a different combination of thrust collars (9) and (25), Illus. 62 or 63, to shift flywheel and rod assembly sideways.

### Installing Cylinders (O.H.V. Engine)

Lubricate cylinder walls, pistons, pins and rod upper bushings generously with engine oil. Also pour about  $\frac{1}{4}$  pint of oil onto rod lower ends. This is an initial crankcase supply to take care of lubrication requirements while oiling system is building up normal pressure and circulation, directly after starting an overhauled engine the first time.

Space ring gaps about equidistant around piston.

Turn engine until crank pin is at bottom center. See that crankcases are clean and install cylinder base gaskets. Cylinders can now be installed over pistons and rings being careful not to change ring gap location. Work cylinders carefully down over rings to avoid any possibility of ring breakage. Install rear cylinder first. Install lock washers and turn on cylinder base nuts and pull them down just snug, not tight. (This is to allow for alignment of intake manifold when installed.) Follow same procedure with front cylinder.

### Attaching Carburetor to Manifold

After servicing carburetor as needed according to information under "Servicing Carburetor," Page 120, attach it to manifold with two heavy (asbestos) gas-



ILLUS. 71  
STRAIGHTENING BENT OR TWISTED CONNECTING ROD

kets between carburetor and manifold. Install lock washers and carburetor-manifold screws and tighten screws securely. If these screws are not tight, an air leak will result, causing carburetion to be erratic. Attach carburetor support bracket and tighten securely. **D i s a s s e m b l e** gasoline strainer—clean thoroughly before installing.

### **Installing Cylinders (Side Valve Engine)**

Lubricate cylinder walls, pistons, pins and rod upper bushings generously with engine oil. Also pour about  $\frac{1}{4}$  pint of oil onto rod lower ends. This is an initial crankcase supply to take care of lubrication requirements while oiling system is building up normal pressure and circulation, directly after starting an overhauled engine the first time.

Space ring gaps about equidistant around piston but do not locate any gap near exhaust valve port, as in this position ring ends may be overheated and burned.

Turn engine until crank pin is at bottom center. See that crankcases are clean and install cylinder base gaskets. Also note that valve cover gaskets on tappet guides are all in place and in good order. If any are damaged or broken, replace them. Cylinders with valves and valve covers assembled can now be installed over pistons and rings being careful not to change ring gap location. Work cylinders carefully down over rings to avoid any possibility of ring breakage. Install rear cylinder first and as

cylinder seats, turn engine so tappets are at their lowest position. Install lock washers and turn on cylinder base nuts and pull them down just snug, not tight. (This is to allow for alignment of intake manifold when installed.) Follow same procedure with front cylinder. In connection with a top overhaul only which does not require removing muffler, insert exhaust pipes into cylinders as they are seated.

Remove top center crankcase stud nut (left side) and drive the stud in flush with crankcase.

Check intake manifold packing bushings to see that they are in good condition. Assemble nuts and bushings to manifold after applying a light coat of oil or grease so bushings will freely adjust themselves to manifold and cylinder nipples as nuts are tightened. Align the hole in carburetor support bracket with top center crankcase stud, then drive stud end through hole in bracket and install stud nut and tighten securely. Turn nuts onto cylinder nipples and tighten securely with Harley-Davidson special wrench, Part No. 12002-30. Unless manifold packing bushings are in good condition and manifold nuts securely tightened there are likely to be air leaks around manifold-cylinder joints. With this condition it will not be possible to get a satisfactory low speed carburetor adjustment.

After manifold is tight, loosen cylinder base nuts slightly to allow final shifting and lining up of cylinders and manifold, then tighten base nuts securely, using Harley-Davidson special wrench, Part No. 12050-30.

---

### **Memoranda**

---



---



---



---



---



---



---



---



---



---



---



---



---



---



---



---



---



---



---



---



## Timing Ignition by Piston Position

(To Identify Items, Refer to Illus. 66 or 67—also Refer to Illus. 72)

With front cylinder head removed, engine can be timed by piston position as an alternative to timing by marks as explained under "Installing Circuit Breaker and Timing Ignition (O.H.V. Engine)," Page 81, or "Installing Circuit Breaker and Timing Ignition (Side Valve Engine)," Page 82.

Timing ignition by piston position may be somewhat more accurate than timing by marks only.

test lamp is explained under "Recommended Re-check of Ignition Timing," Page 83.

Timing ignition for front cylinder automatically times ignition for rear cylinder.

## Installing Cylinder Heads (O.H.V. Engine)

It is recommended that new cylinder head gaskets be used each time heads are installed. This assures leak-free joints. Old gaskets should be re-used only in an emergency when new gaskets are



ILLUS. 72

TIMING IGNITION BY PISTON POSITION

Check point gap (3) with breaker lever fibre block on highest point of cam. Gap should be .022". Adjust by loosening the two lock screws (2) and shifting adjustable contact plate. Measure gap with accurate thickness gauge before and after tightening lock screws.

Turn engine in direction in which it runs, until front piston is  $7/16"$  (O.H.V. Engine), or  $11/32"$  (Side Valve Engine), before top dead center on compression stroke. With piston in this position, adjust circuit breaker so narrow cam (the one with mark) just starts to open points when breaker lever (8) 1946 and earlier Models, or timing adjusting stud—1947 Models, is advanced fully.

An accurate check as to when points just start to open can be made with a test lamp. Use of such a

not available, as in some cases a leak-free joint cannot be obtained with used gasket. Make sure tops of cylinders and cylinder head faces are clean. Apply a light coat of engine oil or grease to both sides of gaskets and install gaskets.

Turn engine so rear cylinder tappets are at their lowest position and install rear cylinder head, push rods and push rod covers in one operation. Be sure push rods register in tappet screw sockets at bottom end and rocker arm ball studs register in push rod sockets at upper end. It is recommended that the three cork washers (6), (11) and (13), Illus. 15, for each push rod cover be renewed.

Install cylinder head bolts with flat washers under head of each bolt. Bolts must be tightened evenly to attain a tight joint. First turn bolts just snug; then



tighten each of them  $\frac{1}{8}$  or  $\frac{1}{4}$  turn at a time until all are securely tightened. Use Harley-Davidson special wrench, Part No. 12650-29. Follow same procedure for installing front cylinder head.

In connection with top overhaul only (which does not require removing muffler), insert exhaust pipes in cylinder heads as heads are lowered onto cylinders.

Remove top center crankcase stud nut (right side) and drive the stud in flush with crankcase.

Check intake manifold packing bushings to see that they are in good condition. Assemble nuts and bushings to manifold after applying a light coat of oil or grease so bushings will freely adjust themselves to manifold and cylinder head nipples as nuts are tightened. Align the hole in carburetor support bracket with top center crankcase stud, then drive stud end through hole in bracket and install stud nut and tighten securely. Turn nuts onto cylinder head nipples and tighten securely with Harley-Davidson special wrench, Part No. 12002-40. Unless manifold packing bushings are in good condition and manifold nuts securely tightened there are likely to be air leaks around manifold-cylinder head joints. With this condition it will not be possible to get a satisfactory low speed carburetor adjustment.

After manifold is tight, loosen cylinder base nuts slightly to allow final shifting and lining up of cylinders and manifold, then tighten base nuts securely, using Harley-Davidson special wrench, Part No. 12050-30.

Cylinder head bracket cannot be installed until after engine is in chassis.

### Installing Cylinder Heads (Side Valve Engine)

It is recommended that new cylinder head gaskets be used each time heads are installed. This assures leak-free joints. Old gaskets should be reused only in an emergency when new gaskets are not available, as in some cases a leak-free joint cannot be obtained with used gasket. Apply a light coat of engine oil or grease to both sides of gaskets. Make sure tops of cylinders are clean and install gaskets. If engine has aluminum heads, place heads on cylinders and install convex washers (large surface against head) and head bolts. Attach cylinder head bracket (mounting lug to left side of engine) with a convex washer between bracket and cylinder head, and a flat washer under head of each bolt, above bracket.

If engine has iron heads, place heads on cylinders and install flat washers and head bolts. Two flat washers are thicker and larger than the others and are to be installed above cylinder head bracket. Attach cylinder head bracket (mounting lug to left side of engine) with smaller flat washers between bracket and cylinder head, and a larger flat washer under head of each bolt, above bracket.

Head bolts must be tightened evenly to attain a tight joint. First turn bolts down just snug; then tighten each of them  $\frac{1}{8}$  to  $\frac{1}{4}$  turn at a time until all are securely tightened. Use Harley-Davidson special wrench, Part No. 12047-30H.

### Adjusting Valve Tappets

Valve tappets must be checked and adjusted each time cylinders—Side Valve Engine, or, cylinders or cylinder heads—O.H.V. Engine, are removed and installed. See "Adjusting Valve Tappets," Pages 22 and 23.

### Installing Engine in Chassis

In connection with top overhaul only, engine is already in chassis and completing assembly is a matter of reversing the procedure followed in disassembly as outlined under "Disassembling Engine for Top Overhaul Only," (O.H.V. Engine), Page 37; (Side Valve Engine), Page 40.

In the case of a complete engine to be installed in chassis, reverse procedure followed in removing engine from chassis as outlined under "Removing Assembled Engine From Chassis for Complete Overhaul," Page 41.

*O.H.V. Engine*—Attach cylinder head bracket and secure to cylinder heads with flat washers, lock washers and nuts; install required number of shim washers to fill space between cylinder head bracket and frame lug, insert bolt through these fittings, and install and securely tighten nut.

*Side Valve Engine*—Pay close attention to the following: Install required number of shim washers to fill space between cylinder head bracket and frame lug, insert bolt through these fittings and install and securely tighten nut; bear in mind that clamp for front spark plug cable is also attached with this bolt.

*All Models*—Be sure throttle and spark control clamps are tightened securely and check very closely to see that throttle opens and closes fully with grip movement and that spark advances fully with grip in inward position. Check clutch, gear shifter and brake controls for correct adjustment. Make close final inspection to be sure all nuts, bolts, screws, etc., are tight.

### Emergency Piston and Ring Service

Need of replacement of rings, or possibly pistons and rings, is indicated by loss of normal compression, overheating, loss of power, abnormal oil consumption, excessive exhaust smoke and piston slap or knock.

As explained under "Refinishing Cylinders Oversize and Fitting New Pistons," Page 45, when pistons develop excessive clearance and slap due to wear or damage and cylinders are found worn more than .002", it is recommended regular practice to smooth and true up cylinder bore by honing, or boring and honing, to the next regular oversize piston step.

However, piston slap alone, due to wear and excessive cylinder-piston clearance, does not necessarily mean otherwise very poor and undependable performance. A good compression seal is the requirement of prime importance for good performance. Therefore, in rendering emergency service, when oversize pistons are not at hand, the main things to be considered are whether or not cylinders are deeply scored and piston ring grooves badly worn sideways.

Even though cylinders and pistons may be worn to the extent of pronounced piston slap, if cylinders are in smooth condition so a new and reasonably good compression seal can be affected by fitting new rings, or new pistons and rings, if ring grooves are badly worn, engine will be good for a further period of dependable performance.

See "Checking Connecting Rod Lower Bearing for Excessive Wear and Looseness," Page 40.

### Piston and Pin

(Removing and Installing)

Piston pin, properly fitted, is a light hand press fit in piston and has .001" clearance in connecting rod upper bearing. The pin is secured in piston by means of a spring lock ring at each end of pin. Lock rings fit into grooves in pin and grip pin with considerable tension.

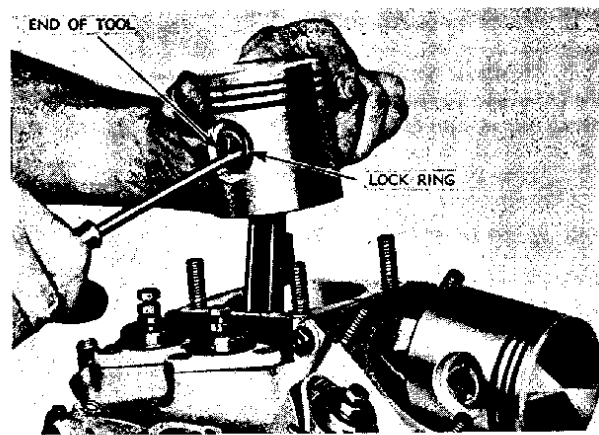

ILLUS. 73  
REMOVING LOCK RING FROM PISTON PIN

In removing piston pin, first remove lock ring from end of pin that is slotted. Slot permits getting a screwdriver underneath lock ring and forcing it off. Use end of special tool specified below as a rest for screwdriver (see Illus. 73). Pin can then be driven out of piston. Use a drift of proper size to avoid damaging end of pin and piston boss and strike light hammer blows to avoid bending connecting rod.

If piston pin is to be used again, examine lock ring on unslotted end of pin and if ring is tight in its groove and undamaged it is not necessary to disturb it. If a new ring is required, clean ring groove and install ring before pin is installed in piston. Piston pin included with new piston assembly will have lock ring already installed on unslotted end.

When reassembling piston to rod, after giving due attention to correct fit of pin in both, piston and rod upper bearing, clean lock ring groove and install lock ring on end of pin that is not slotted. Start slotted end of pin into piston boss and drive through in the same manner in which pin was removed.

If the piston (but not the pin) is heated about as hot as it can be handled before pin is started, pin will drive through easier than in a piston at room temperature. After pin is in place, clean lock ring groove and install the other lock ring (see Illus. 74). It is important that Harley-Davidson special lock ring tool, Part No. 12052-32, be used for installing lock rings, as with this tool lock ring is expanded just enough to go over end of pin. Other means of installing may over-expand ring and possibly crack it. Make sure ring groove is clean and that ring seats firmly in groove; if it doesn't, discard it and install another new one. A lock ring loosely installed will rapidly loosen further in service and finally will come off pin, resulting in both piston and cylinder soon being damaged beyond repair. *Never install a used lock ring or a new one if it has been installed and then removed for any reason, always use a new lock ring.*

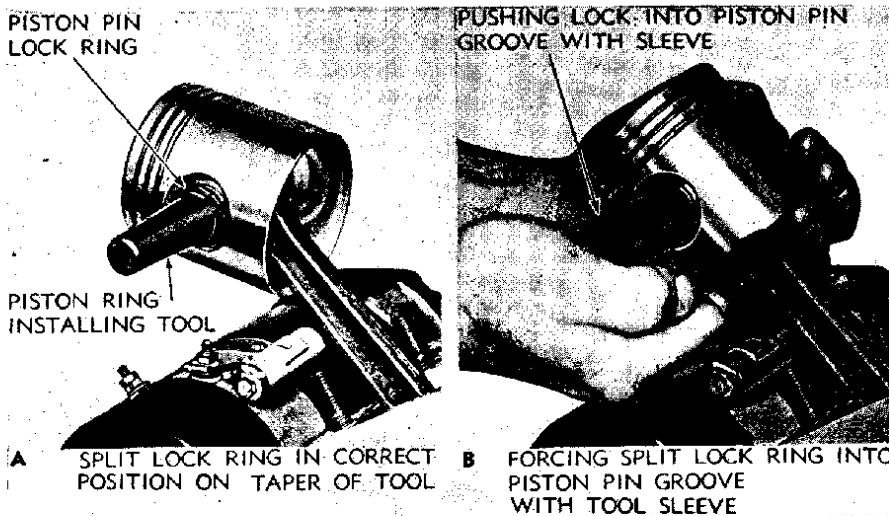

ILLUS. 74  
INSTALLING PISTON PIN LOCK RING

All pistons, including 61" O.H.V. pistons in the lower oversize steps, have two horizontal slots, one front and one rear, in bottom ring groove. 61" O.H.V. piston in the larger oversize steps is slotted horizontally and also has a vertical slot in one thrust face. Piston with only the horizontal slots may be installed with either thrust face to the front. Piston with vertical slot in one thrust face must be installed with that thrust face to the front.

Pistons obtained from the factory, standard or oversize, are fitted with pin correctly fitted and piston rings installed. Piston pin lock rings are also supplied, one assembled on pin, the other one loose. Check ring gaps in cylinder being refitted.

### Piston Rings

Piston rings are of three types—compression (plain face) ring; standard type oil control (channeled face) ring; special type oil control (slotted face) ring.

Piston rings are to be installed as follows:

61" O.H.V. Engine (except in city police service) and 74" and 80" Side Valve Engine—front piston, three compression rings; rear piston, one standard type oil control ring (in bottom groove) and two compression rings.

74" O.H.V. Engine (except in city police service)—each piston, one standard type oil control ring (in bottom groove) and two compression rings.

61" and 74" O.H.V. Engine (in city police service)—each piston, one special type oil control ring (in bottom groove) and two compression rings.

Piston rings are regularly supplied in following oversizes:

Compression rings and standard type oil control

rings—.005", .010", .020", .030", .040", .050", .060" and .070".

Special type oil control rings—.005", .010", .020", .030" and .040".

Piston rings must have proper side clearance in ring grooves. In new assembly, this is .004". Check with thickness gauge as shown in Illus. 76. Maximum permissible side clearance is .008".

Standard ring gap between ends of rings when inserted squarely in cylinder bore is .010" to .020".

To check piston ring gap place a piston in cylinder with top end of piston about 1/2" from top end of cylinder as shown in Illus. 77. Set the ring to be checked in cylinder bore squarely against piston. With a thickness gauge check ring gap as shown in Illus. 77. Even though ring gap may be slightly greater than standard, only standard size piston rings should be used in cylinder unless cylinder has been refinished oversize.

If cylinder has been refinished oversize, then use the correct oversize rings, fitting rings to give standard gap.

If gap is less than .010", ring ends may butt under expansion, and rings may be scored or broken. Gap may be increased by filing with a fine-cut file.

When installing piston rings be sure compression rings and oil control rings are placed in their proper grooves.

Use thin strips of metal to guide and slip rings over the piston into their respective grooves without overexpanding or twisting rings and damaging the finely finished piston surface. See Illus. 75. Thin strips can also be used to good advantage when removing piston rings.

Note: Examine rings to determine if "TOP" is stamped on one side. If so, install ring with "TOP" upward.

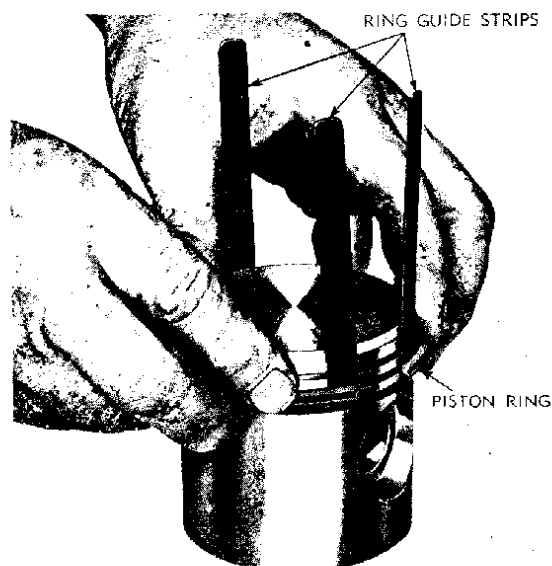

ILLUS. 75  
REMOVING PISTON RINGS

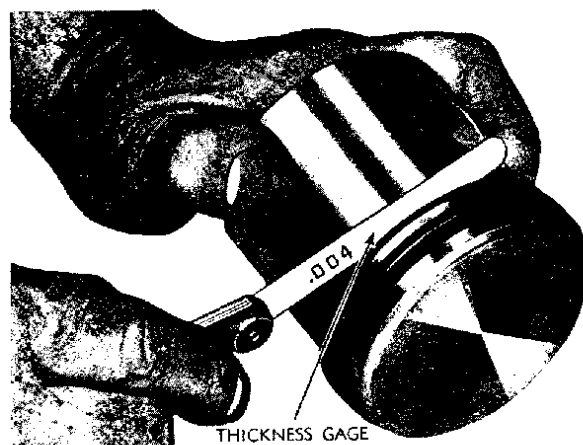

ILLUS. 76  
MEASURING RING CLEARANCE IN PISTON GROOVES

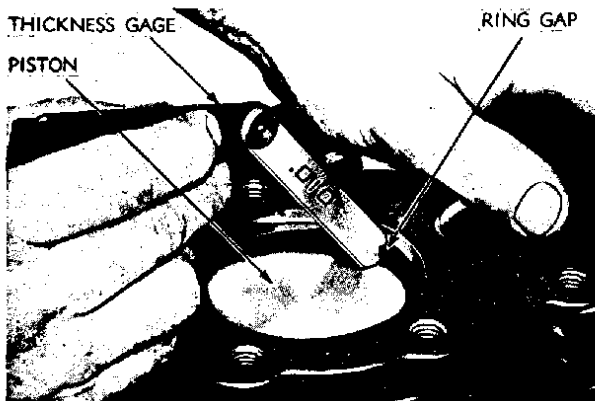

ILLUS. 77  
MEASURING PISTON RING GAP

### Installing and Fitting Connecting Rod Upper Bushing

Connecting rod upper end bronze bushing may need to be renewed either due to wear and excessive pin clearance or due to becoming loose in rod. Inspect for both conditions.

When bushing is found tight in rod but is worn to excessive pin clearance (.002" or more) it is, of course, possible to service it by reaming oversize and fitting an oversize pin. However, it is better practice to install a new bushing and ream it to fit a standard pin, except when piston to be used had previously been fitted with oversize pin or pin is loose in bosses, necessitating fitting with larger pin. The principal objection to fitting upper end oversize is that considerably more time is required for the job. New pistons obtained from factory are supplied correctly fitted with standard pin, and installing one is a short job if the rod bushing is already reamed to standard size. If bushing has been reamed oversize, either new bushing must be installed and reamed to standard size or piston must be reamed oversize to fit an oversize pin, which involves extra time.

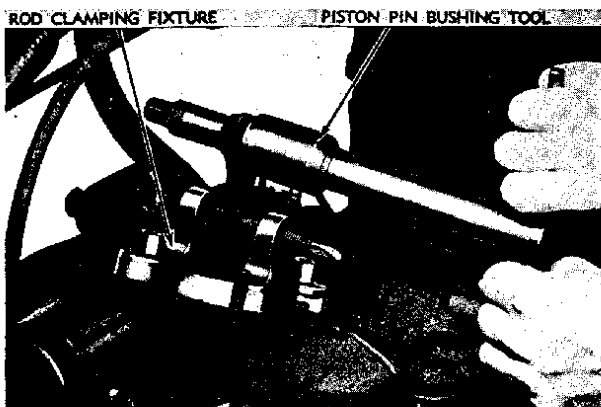

ILLUS. 78  
INSTALLING NEW CONNECTING ROD BUSHING

When installing new upper end bushings in rods disassembled from engine, an arbor press, if available, is usually used to press out old bushings and press in the new. When renewing bushings in connection with only a top overhaul, use Harley-Davidson special tools as shown in Illus. 78—bushing tool, Part No. 12057-X, and connecting rod clamping fixture, Part No. 12058-X. Be careful to start new bushings with oil slot in alignment with oil slot in rod.

Ream new bushing to size, or preferably, ream nearly to size and finish to exact size with a hone (Harley-Davidson special reamer, Part No. 11915-X; Harley-Davidson special hone, Part No. 11844-X). A properly fitted pin should have .001" clearance; with this clearance, pin will have just noticeable shake in bushing. Fitting tighter is likely to result in a seized pin or bushing loosened in rod.

Oversize piston pins are available in the following oversizes: .002", .004", .006", .008", .010", .012" and .015".

After installing new connecting rod upper end bushings in connection with only a top overhaul, connecting rod alignment must be checked the same as when an engine is completely overhauled. See "Aligning Connecting Rods," Page 83.

### Memoranda

---

---

---

---

---

---

---

---

---

---

---

---

---

---

---

---

---

---

---

---

---

---

---

---



## SUMMARY OF ENGINE SPECIFICATIONS (Fitting and Adjusting)

**CYLINDER:** Standard bore—O.H.V. Engine: 61"—3.3125"; 74"—3.4375". Side Valve Engine: 74"—3.3125"; 80"—3.422".

**PISTON CLEARANCE IN CYLINDER:** .001" to .002", measuring piston at bottom of skirt, front to rear. Piston shapes to cylinder and acquires more clearance after short time in service. Measure cylinder about ½" from top of bore, front to rear. Warning: This fitting clearance applies only to genuine Harley-Davidson taper-cam ground piston, which is smaller at top of skirt, underneath lower ring, than at bottom of skirt. This clearance (.001" to .002") is not sufficient for straight-cam ground piston obtained from some other source.

**PISTON-CYLINDER HEAD CLEARANCE:** Side Valve Engine—1/16" to 3/32" with piston at top center.

**PISTON PIN IN PISTON:** Light hand press fit.

**PISTON PIN IN CONNECTING ROD UPPER BUSHING:** .0008" to .0012" loose.

**PISTON RING GAP:** .010" to .020".

**PISTON RING SIDE CLEARANCE IN GROOVES:** .004".

**CONNECTING ROD LOWER END BEARING:** .001" to .0012" loose.

**CONNECTING ROD LOWER END SIDE PLAY:** Forked rod must have .006" to .010" play between flywheels. Roller and retainer assembly must be narrower, but not more than .010" narrower, than forked rod.

**PINION GEAR SHAFT:** .0008" to .0012" loose in roller bearing and .0005" to .0012" loose in timing gear case cover bushing. Note: When new cover bushing is installed, oil transfer hole in bushing must be located as follows: O.H.V. Engine—oil transfer hole in bushing must line up with drilled oil passage in gear case cover; Side Valve Engine—oil transfer hole in bushing must be upward and 30° ahead (toward front of engine) of vertical center line.

**SPROCKET SHAFT:** .0005" to .001" loose in roller bearing; .007" to .009" loose in oil retaining bushing.

**FLYWHEEL ASSEMBLY:** .012" to .014" endplay in crankcase.

**CAM GEARS:** O.H.V. Engine—.001" to .0015" clearance in crankcase and gear case cover bushings; free to .005" endplay; Side Valve Engine—.0005" to .001" clearance in crankcase and gear case cover bushings; free to .007" endplay.

**INTERMEDIATE GEARS:** .001" to .0015" loose on studs.

**VALVE STEM-VALVE GUIDE CLEARANCE:** O.H.V. Engine—.004" to .006"; Side Valve Engine—.003" to .0055".

**TAPPET GUIDES:** .0005" to .001" press fit in crankcase.

**VALVE TAPPET—TAPPET GUIDE CLEARANCE:** O.H.V. Engine—.0008" to .0017"; Side Valve Engine—.0005" to .001".

**ROCKER ARM FIT ON SHAFT:** O.H.V. Engine—.0005" to .0015" loose—.007" to .016" endplay.

**OIL PUMP DRIVE SHAFT:** O.H.V. Engine—.0008" to .0012" loose in crankcase bushing.

**TAPPET CLEARANCE:** Engine Cold: O.H.V. Engine—push rods just noticeable play or shake, and can be turned freely with finger tips, completely around, without any trace of bind. Side Valve Engine—intake .004" to .005"; exhaust .007" to .008".

**CIRCUIT BREAKER POINTS:** .022" gap with breaker lever fibre on highest point of cam.

**IGNITION TIMING:** O.H.V. Engine—7/16" before top dead center; Side Valve Engine—11/32" before top dead center; time according to flywheel mark, Page 81 or 82, or by piston position, Page 86.

**CRANKCASE BREATHER TIMING:** O.H.V. Engine—breather valve gear engaged with marks in alignment (see Illus. 64). Side Valve Engine—See Page 70.

**VALVE TIMING:** Time according to gear marks (see Page 78). Tappets to be adjusted first.

**CHECKING VALVE TIMING:** All O.H.V. Engines—adjust all valve tappets temporarily to .004" clearance. Turn engine in direction it runs until valve being checked is open .001" before measuring piston position. After timing has been checked, valve tappets must be readjusted to the correct clearance, see "Adjusting Valve Tappets," Page 22.

61" O.H.V. Engine—intake valve opens when piston is 19/64" to 25/64" before top dead center and closes when piston is 29/32" to 1-3/32" after bottom dead center. Exhaust valve opens when piston is 23/32" to 29/32" before bottom dead center and closes when piston is 19/64" to 25/64" after top dead center.

74" O.H.V. Engine—intake valve opens when piston is 23/64" to 29/64" before top dead center and closes when piston is 1-1/64" to 1-13/64" after bottom dead center. Exhaust valve opens when piston is 13/16" to 1" before bottom dead center and closes when piston is 23/64" to 29/64" after top dead center.

Side Valve Engine—intake and exhaust valve tappets adjusted to running clearance—intake valve tappets .004" to .005"; exhaust valve tappets .007" to .008". Turn engine in direction it runs until valve being checked is just starting to open before measuring piston position.

Intake valve opens when piston is 9/32" to 13/32" before top dead center and closes when piston is 7/8" to 1 1/8" after bottom dead center. Exhaust valve opens when piston is 5/8" to 7/8" before bottom dead center and closes when piston is 1/4" to 3/4" after top dead center.

**OIL PUMP ADJUSTMENT:** Normal setting—O.H.V. Models—end of pressure regulating valve adjusting screw 3/8" below end of valve chamber. Side Valve Models—1940 and earlier Models—pressure regulating valve adjusting screw nine complete turns open from closed position, 1941 and later Models—end of pressure regulating valve adjusting screw 3/8" below top of pump body. See "Adjusting Oil Feed Pump," Page 28.

**FRONT CHAIN OILER ADJUSTMENT:** Initial factory setting—O.H.V. Models—adjusted with the required washers under adjusting screw head to hold screw point 1 full turn off its seat. Make further adjustments as needed to meet actual service requirements. See "Lubricating Front Chain," Page 12. Side Valve Models—adjusted with the required washers under adjusting screw head to hold screw point 1 1/2 turns off its seat. Make further adjustments as needed to meet actual service requirements. See "Lubricating Front Chain," Page 12.

**REAR CHAIN OILER ADJUSTMENT:** (Installed on a few motorcycles): Initial factory setting—adjusted with the required washers under adjusting screw head to hold screw point 1/2 turn off its seat. Make further adjustments as needed to meet actual service requirements. See "Lubricating Rear Chain," Page 14.



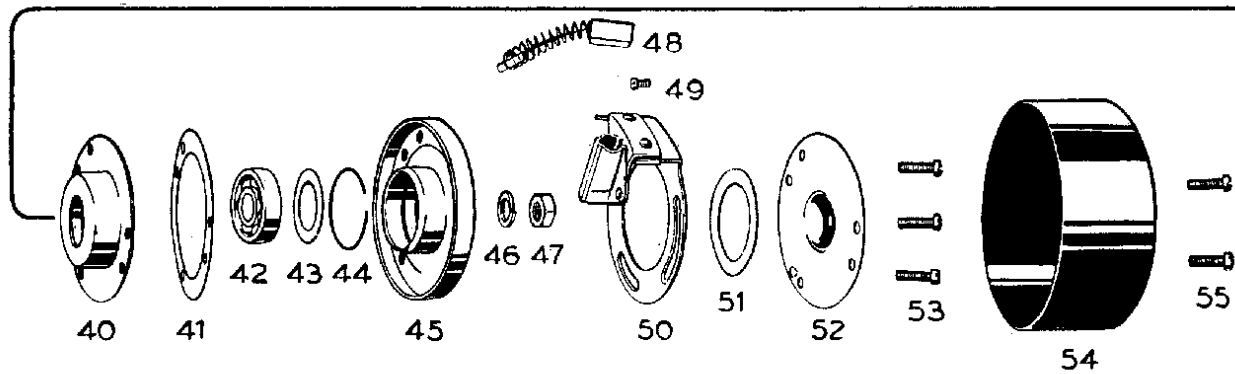
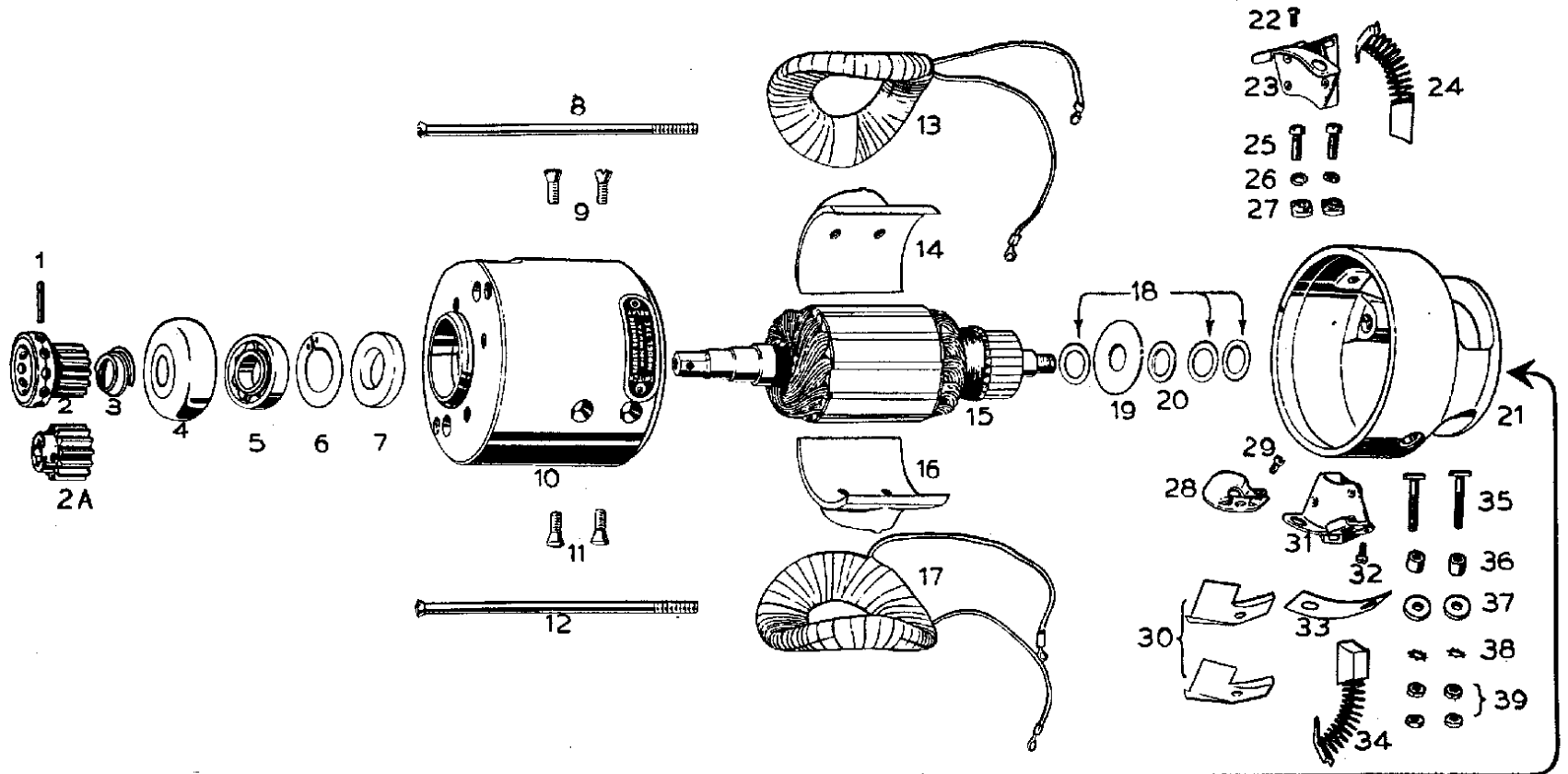

## STANDARD GENERATOR ASSEMBLY

(Item Numbers Refer to Illus. 79)

ITEM	NUMBER USED	PART NUMBER	NAME
1	1	634-32	Drive Gear Pin
2	1	632-37	Drive Gear (Side Valve Models)
2A	1	632-30	Drive Gear (O.H.V. Models)
3	1	1647-31B	Drive End Spring
4	1	1646-31	Oil Deflector
5	1	1644-30	Drive End Bearing (large)
6	1	1647-31D	Spring Ring
7	1	1647-31C	Felt Oil Retainer—See paragraph 11 under "Disassembling Generator," Page 99
8	2	1506-32	Frame End Screw (same as Item 12)
9	4	1512-18	Pole Shoe Screw (same as Item 11)
10	1	1504-32	Frame
11	See Item 9	.....	.....
12	See Item 8	.....	.....
13	1	1507-32	Shunt Field Coil (White identification mark)
14	2	1511-30	Pole Shoe (same as Item 16)
15	1	1636-32	Armature
16	See Item 14	.....	.....
17	1	1508-32	Regulating Field Coil (Orange identification mark)
18	3	1643-29	Armature Steel Spacer (.025")
19	1	1642-29	Armature Bakelite Washer
20	1	1643-30	Armature Steel Spacer (.072")
21	1	1505-32	Frame End
22	4	010	Terminal Screw (same as Items 29, 32 and 49)
23	2	1661-32	Brush Holder (same as Item 31)
24	2	1669-32	Brush (same as Item 34)
25	2	036	Brush Holder Bolt
26	2	0254	Lock Washer
27	2	1667-32	Nut
28	1	1663-32B	Shunt Field Coil Terminal
29	See Item 22	.....	.....
30	2	1663-32A	Shunt Field Coil Terminal Insulation
31	See Item 23	.....	.....
32	See Item 22	.....	.....
33	1	1663-32	Positive Brush Holder Insulation
34	See Item 24	.....	.....
35	2	1664-32	External Terminal Bolt
36	2	1665-32	Terminal Bolt Bushing
37	2	1666-32	Insulating Washer
38	2	0354	Lock Washer
39	4	0105	Nut
40	1	1641-30A	Grease Retainer, Inner
41	1	1697-30	Gasket
42	1	1644-18	Commutator End Bearing
43	1	1639-18	Spacing Shim (.020")
44	1	1647-29A	Spring Ring (1 $\frac{1}{16}$ " diameter)
45	1	1647-32	Bearing Housing
46	1	0261	Lock Washer
47	1	0129	Armature Shaft Nut
48	1	1671-26	Third (regulating) Brush (small)
49	See Item 22	.....	.....
50	1	1662-32	Third (regulating) Brush Holder
51	1	1642-30	Gasket
52	1	1641-33	Grease Retainer, Outer
53	5	.037	Screw (same as Item 55)
54	1	1696-32	End Cover
55	See Item 53	.....	.....

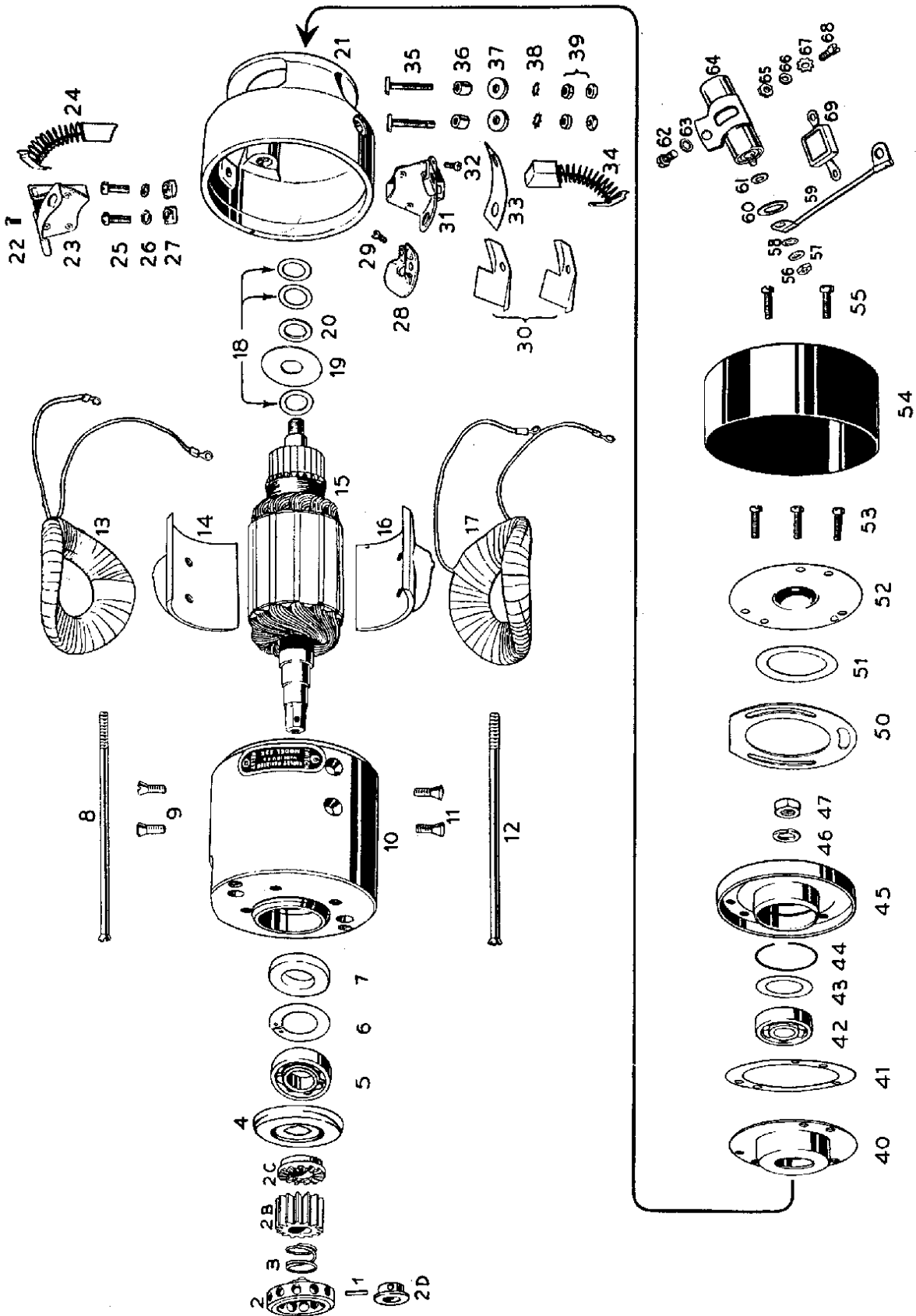

ILLUS. 80  
RADIO (TWO BRUSH) GENERATOR DISASSEMBLED

## RADIO (TWO BRUSH) GENERATOR ASSEMBLY

(Item Numbers Refer to Illus. 80)

ITEM	NUMBER USED	PART NUMBER	NAME
1	1	634-32	Drive Gear Pin
2	1	1658-37	Oil Centrifuge (Side Valve Models)
2B	1	632-32A	Drive Gear
2C	1	1654-32	Generator Clutch
2D	1	1656-32	Clutch Spring Collar (O.H.V. Models)
3	1	1647-31B	Drive End Spring
4	1	1646-32	Oil Deflector
5	1	1644-30	Drive End Bearing (large)
6	1	1647-31D	Spring Ring
7	1	1647-31C	Felt Oil Retainer
8	2	1506-32A	Frame End Screw (same as Item 12)
9	4	1512-18	Pole Shoe Screw (same as Item 11)
10	1	1504-32A	Frame
11	See Item 9		
12	See Item 8		
13	1	1507-32A	Shunt Field Coil (White identification mark)
14	2	1511-32	Pole Shoe (same as Item 16)
15	1	1636-32A	Armature
16	See Item 14		
17	1	1508-32A	Regulating Field Coil (Orange identification mark)
18	3	1643-29	Armature Steel Spacer (.025")
19	1	1642-29	Armature Bakelite Washer
20	1	1643-30	Armature Steel Spacer (.072")
21	1	1505-32	Frame End
22	3	010	Terminal Screw (same as Items 29 and 32)
23	2	1661-32	Brush Holder (same as Item 31)
24	2	1669-32	Brush (same as Item 34)
25	2	036	Brush Holder Bolt
26	2	0254	Lock Washer
27	2	1667-32	Nut
28	1	1663-32B	Field Coil Terminal
29	See Item 22		
30	2	1663-32A	Field Coil Terminal Insulation
31	See Item 23		
32	See Item 22		
33	1	1663-32	Positive Brush Holder Insulation
34	See Item 24		
35	2	1664-32	External Terminal Bolt
36	2	1665-32	Terminal Bolt Bushing
37	2	1666-32	Insulating Washer
38	2	0354	Shakeproof Lock Washer
39	4	0105	Nut
40	1	1641-30A	Grease Retainer, Inner
41	1	1697-30	Gasket
42	1	1644-18	Commutator End Bearing
43	1	1639-18	Spacing Shim (.020")
44	1	1647-29A	Spring Ring (1 1/8" diameter)
45	1	1647-32	Bearing Housing
46	1	0261	Lock Washer
47	1	0129	Armature Shaft Nut
50	1	1662-38	Generator End Plate
51	1	1642-30	Gasket
52	1	1641-33	Grease Retainer, Outer
53	5	037	Screw (same as Item 55)
54	1	1696-32	End Cover
55	See Item 53		
56	1	0103	Nut
57	2	0204	Plain Washer (same as Item 61)
58	1	0352	Shakeproof Lock Washer
59	1	8360-32A	Condenser Wire
60	1	1629-41	Insulating Washer
61	See Item 57		
62	1	019	Screw
63	1	0352	Lock Washer
64	1	1629-30R	Condenser
65	1	0105	Nut
66	1	0254	Lock Washer
67	1	0354	Shakeproof Lock Washer
68	1	035	Screw
69	1	8358-39	Mica Capacitor, .0005 mf (used only with General Electric ultra-high-frequency receiver)

FOOTNOTE: Illus. 80 applies to radio (three brush) generator, except endplate (50).

Instead of endplate (50) Illus. 80, the following parts shown in Illus. 79 are used—third (regulating) brush holder (50), third (regulating) brush (48) and terminal screw (49).

## ELECTRICAL SYSTEM

Electrical system is a 6-volt, one wire ground return system with negative ground. Three-brush generator is regulated by the third or regulating brush and "lamp load." Lamp load regulation is accomplished by connecting "shunt" field winding in the lighting circuit. When lamps are turned "ON" this field is energized and generator output is increased to carry load of lighting equipment. Two-brush generator is regulated entirely by current and voltage regulator.

Generator models are identified as follows:

Standard Generator—Model 32E

Radio (three brush) Generator—Model 32E2

Radio (two brush) Generator—Model 32E2 and 32E2R

### When Generator Fails to Charge

When generator apparently quits charging (indicated by signal light in switch panel staying lit or battery going dead—see "Instrument Panel Signal Lights," Page 5), the trouble may be of such nature that repairs can be made without removing generator. Follow procedure outlined below, step by step, until the trouble is located.

1. Remove black wire from generator signal light terminal on relay if a three brush generator, or generator signal light green wire from generator "relay" terminal if a two brush generator, and keep wire end from touching any part of motorcycle. Turn ignition switch "ON." If wire is not grounded, signal light in instrument panel will remain out—if grounded, light will go on. With engine running at fast idling speed and wire grounded, signal light in instrument panel will remain on whether or not generator is charging.

2. Test the battery and if its condition is questionable replace with fully charged battery before making further tests.

3. Remove left footboard and clutch footpedal assembly.

4. Disconnect any condensers found connected to generator "relay" terminal and generator frame end or cover. A shorted condenser will prevent generator charging. Do not as yet remove resistor from generator "relay" and "switch" terminals of a radio (three brush) generator.

5. Remove generator end cover and inspect brushes to make sure they are not worn out, broken or gummy and sticking in brush holders.

6. See that commutator is not excessively oily, dirty or gummy. See "Cleaning Commutator," Page 103.

7. Make sure brush holders are not bent and possibly striking shoulder on commutator.

8. If the fault is not found through above checks, it may be in cut-out relay, current and voltage regulator if motorcycle is so equipped, or in wiring between generator and battery.

To check whether trouble is in generator, relay or current and voltage regulator, or wiring between generator and battery:

A. Connect an ammeter (two-brush generator, use at least an 0-30 ampere scale ammeter) between battery negative (right) terminal and ground.

B. Disconnect wires from generator "relay" terminal and battery positive terminal and connect a jumper wire directly between these two terminals. Also, if generator is two-brush type, disconnect wire from generator "switch" terminal and temporarily connect a short length of wire between generator "switch" terminal and ground. A convenient ground connection can be made by connecting wire to generator end with a commutator end cover screw.

### Standard and Radio (three brush) Generator:

C. Start and speed up engine and check reading of ammeter. If generator shows normal charge (see "Generator Charging Rate," Page 103) trouble is in cut-out relay (see "Cut-Out Relay," Page 105) or in wiring between relay and battery (see "Wiring Diagram," Page 114 or 115). If standard generator shows no charge, it must be removed for further attention. If radio generator shows no charge, check resistor connected to "relay" and "switch" terminals to make sure it is not defective and grounding to generator frame end. If not grounded generator must be removed for further attention.

### Radio (two brush) Generator:

D. Start and speed up engine and check reading of ammeter. If generator shows charge of 15 amperes minimum, trouble is in cut-out relay (incorporated with current and voltage regulator), in wiring between generator "relay" terminal and regulator "GEN" terminal, in wiring between regulator "BAT" terminal and battery, in wiring between generator "switch" terminal and regulator "F" terminal (see "Wiring Diagram," Page 112 or 117) or in current and voltage regulator (see "Current and Voltage Regulator," Page 106). If generator shows no charge it must be removed for further attention.

REMOVE GENERATOR SCREWS



ILLUS. 81

REMOVING GENERATOR END MOUNTING SCREWS



## Removing Generator

1. Disconnect wires from generator "switch" and "relay" terminals.

2. Remove the two long screws, through timing gear case cover, that secure end of generator against gear case (see Illus. 81).

3. Remove nut, lock washer and convex washer from end of strap that clamps generator in its cradle on crankcase (see Illus. 82).

4. *Side Valve Engine:* Lift strap high enough to permit raising generator so oil centrifuge (on end of generator gear or on armature shaft) will clear adjacent gear and allow generator to be removed from engine.

*O.H.V. Engine:* Generator has no oil centrifuge and can be pulled straight out.

5. Be sure to observe and count number of paper shims between generator and cradle. Lay these shims aside to be used again when generator is re-installed. Also note location of hole in shims for oil drain. These shims were required in original assembly to adjust driving gears for proper mesh and, if left out, gears are still likely to mesh too deeply and howl, even though they have seen considerable service.

Note: In 1945, diameter of standard generator drive gear on *O.H.V. Models* only was increased. The larger diameter gear can be identified by measuring its outside diameter. Outside diameter of larger gear is 1.022", however, if edges of gear teeth are slightly burred, outside diameter of gear sion given. Diameter of smaller gear used previously was 1.000".

6. Unless a new generator gasket is available, to be used when generator is installed, be careful not to damage the old one.

GENERATOR SCREWS



GENERATOR CLAMP STRAP

ILLUS. 82  
REMOVING GENERATOR STRAP NUT

## Testing Field Coils and Brush Holders Without Disassembling Generator

**CAUTION:** Overloading ammeter, due to short circuit or otherwise, will damage it. Overload is indicated by needle going beyond range of calibrated scale; direct short is indicated by needle swinging violently to extreme limit of its travel. In either case, contact must be broken instantaneously to avoid damaging or burning out ammeter. Therefore, in making the following tests with ammeter, first make only a momentary contact to determine if a short exists. If ammeter needle does not go beyond calibrated scale, it is safe to make continuous contact and proceed with test as described.

As an added precaution, in making tests with ammeter, always work on a bench with an insulated top. This will prevent shorting through bench top.

Never touch test points together.

Connect a fully charged battery to suitable test ammeter and test points as shown in Illus. 83.

Remove the brushes from their holders (see "Inspecting or Replacing Generator Brushes," Page 103). Removing main brushes requires removing screws connecting field coil terminal wires to brush holders.

### Model 32E and 32E2 - Standard and Radio Three Brush Generator

1. Remove resistor from generator "relay" and "switch" terminals of a Radio generator before making tests.

2. Reconnect field coil wires to positive and negative brush holders before making tests.

*Testing Regulating Field Coil (see Illus. 83):*

3. Touch test point "A" to "relay" terminal of generator and test point "B" to third (regulating) brush holder. The ammeter should read as follows:

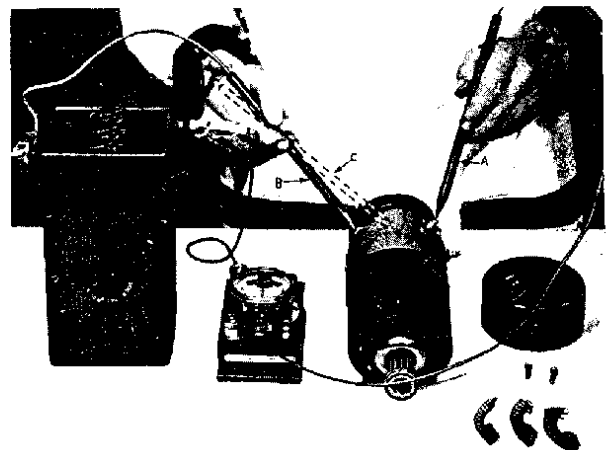

ILLUS. 83  
TESTING REGULATING FIELD COIL STANDARD AND RADIO THREE BRUSH GENERATOR

Standard Generator from 1.4 to 1.9 amperes; Radio Generator, 1.9 to 2.3 amperes. If ammeter shows no reading, field coil is open (see that terminal connections are tight and field coil wires are not broken at terminals). If reading is appreciably higher than—Standard Generator 1.9 amperes; Radio Generator, 2.3 amperes, field coil is shorted internally.

4. With test point "A" still on "relay" terminal, ground other test point by moving it to generator frame as indicated by dotted line "C". Ammeter should show no reading on this test. If ammeter registers a reading, field coil, "relay" terminal, positive brush holder or third brush holder is grounded. If test shows ground, disconnect field coil wire from third brush holder. If trouble is eliminated, third brush holder is grounded. If ground still exists, disconnect field lead from positive brush holder. If trouble is now eliminated, ground is in field coil. If ground still exists the positive brush holder or "relay" terminal is grounded.

**Testing Shunt Field Coil (see Illus. 84):**

5. Touch test point "D" to "switch" terminal and test point "E" to negative brush holder (this brush holder is grounded) or on generator frame. Ammeter should read as follows: Standard Generator,



ILLUS. 84  
TESTING SHUNT FIELD COIL—STANDARD AND RADIO THREE BRUSH GENERATOR

from .6 to 1.0 ampere; Radio Generator, .8 to 1.2 amperes. If ammeter shows no reading, coil is open (see that terminal connections are tight and field coil wires are not broken at terminals). If reading is appreciably higher than—Standard Generator 1.0 ampere; Radio Generator 1.2 amperes, coil is shorted internally or grounded, or "switch" terminal is grounded.

**Model 32E2 and 32E2R—Radio Two Brush Generator**

Field coil wires disconnected when positive (upper) brush is removed, must remain disconnected and terminals must not touch any part of generator frame when making tests. Do not disconnect field

coil wires from field coil wire terminal (connected with "switch" terminal) unless necessary.

**Testing Regulating Field Coil (see Illus. 85):**

1. Touch test point "F" to "switch" terminal of generator and test point "G" to disconnected regulating field coil wire terminal. The ammeter should read between 1.9 to 2.3 amperes. If ammeter shows no reading, field coil is open (see that terminal connections are tight and field coil wires are not broken at terminals). If reading is appreciably higher than 2.3 amperes, field coil is shorted internally.

2. With test point "F" still on switch terminal, ground other test point by moving it to generator frame, as indicated by dotted lines "I". Ammeter should show no reading on this test. If ammeter registers a reading, either or both field coils, or "switch" terminal is grounded.

3. If test shows ground, disconnect field coil wires from field coil terminal. If ground is eliminated, one or both field coils are grounded. If ground still exists, "switch" terminal is grounded.

**Testing Shunt Field Coil (see Illus. 85):**

4. If testing regulating field coil did not necessitate disconnecting field coil wires from field coil terminal because of a ground, touch test point "F" to "switch" terminal and other test point to disconnected shunt field coil wire as indicated by dotted lines "H". The ammeter should read .8 to 1.2 amperes. If ammeter shows no reading field coil is open (see that terminal connections are tight and field coil wires are not broken at terminals). If reading is appreciably higher than 1.2 amperes coil is shorted internally.

5. If test showed that a field coil is grounded, the defective coil can be identified by ammeter registering a reading when touching test point "F" to one field coil wire terminal and other test point to generator frame. Check each field coil separately.

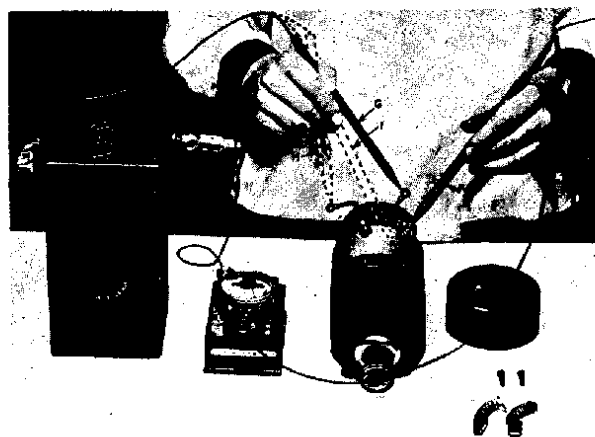

ILLUS. 85  
TESTING REGULATING AND SHUNT FIELD COILS—RADIO TWO BRUSH GENERATOR

**Testing Relay Terminal and Positive Brush Holder (see Illus. 86):**

6. Touch test point "J" to "relay" terminal and test point "K" to generator frame. Ammeter should show no reading. If ammeter registers a reading, positive brush holder or "relay" terminal is grounded.

Make sure negative brush holder is tight and making good contact with frame end to insure a good ground connection.

If field coils, brush holders and generator terminals test O.K., armature must be removed and tested.

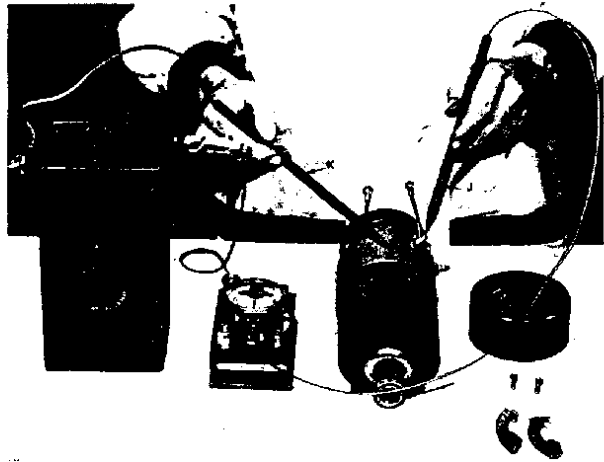

ILLUS. 86

TESTING RELAY TERMINAL—RADIO TWO BRUSH GENERATOR

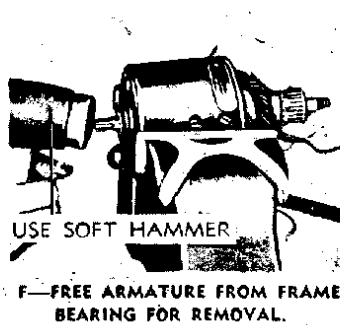
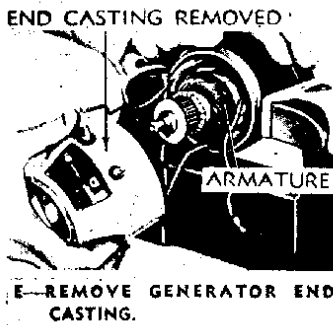
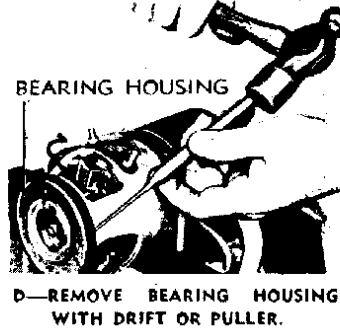
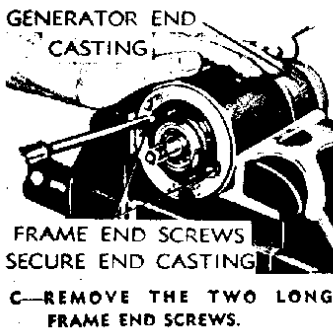
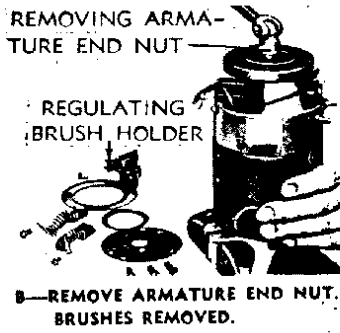
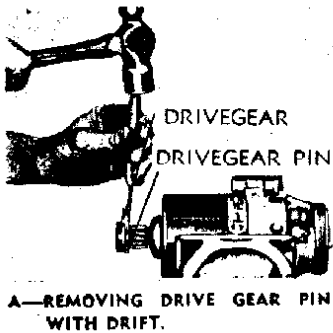

ILLUS. 87

DISASSEMBLING GENERATOR

**Disassembling Generator**

(To Identify Items, Refer to Illus. 79 or 80—also Refer to Illus. 87 and 88)

1. End cover and brushes have already been removed for previous checking and testing.

2. Disconnect field wires. Closely observe how field coil wires are arranged to keep them in the clear so they will not be damaged by armature. One is pulled between generator frame and frame end screw, and one is brought over the outside of aluminum frame end. Also, excess slack is avoided by winding wires together, where they cross at brush holders. The arrangement of wires shown in Illus. 88 applies to three brush type generator only, but method of winding wires together to keep them in the clear also applies to two brush type generator. Note this arrangement and arrange wires in the same manner when reassembling.

3. Standard Generator—remove pin from drive gear; remove gear, spring and oil deflector (1, 2, 3 and 4).

Radio (Two Brush) or (Three Brush) Generator—remove pin from oil centrifuge or clutch spring collar; remove oil centrifuge or clutch spring collar, spring, gear, clutch and oil deflector (1, 2, or 2D, 3, 2B, 2C, and 4).

4. Clamp armature shaft in copper-faced vise jaws with generator in upright position.

5. Take out three end screws and remove outer grease retainer, gasket and third brush holder, or generator end plate (50, 51, 52 and 53).

6. Remove armature shaft nut and lock washer (46) and (47).

7. Remove bearing housing, gasket, bearing and inner grease retainer (40, 41, 42 and 45).

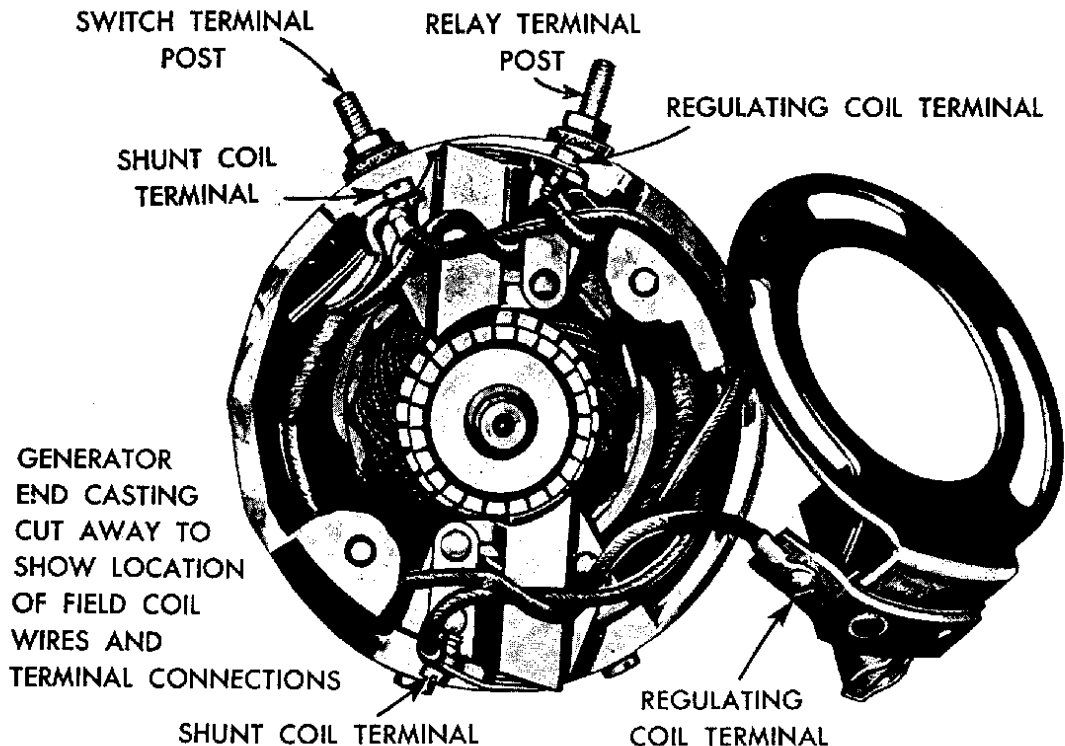

ILLUS. 88  
GENERATOR SECTION SHOWING ARRANGEMENT AND CONNECTIONS FOR FIELD COIL LEADS—  
THREE BRUSH GENERATOR

8. Remove steel and fibre washers from armature shaft (18, 19 and 20).

9. Take generator out of vise and remove frame end screws (8) and (12). If gasket is still on end of generator frame, it will have to be removed to uncover the heads of these screws. Before turning screws all the way out (leave at least two threads engaged), tap them lightly to drive aluminum frame end (21) off frame (10).

10. Remove armature (15) from frame by tapping drive end of shaft lightly with a soft hammer.

11. Drive end bearing can now be removed; also spring ring and felt oil retainer (5, 6 and 7). Later 1946 and 1947 *Standard Generator* only has an oil seal in place of felt oil retainer (7).

12. Do not remove pole shoes and field coils (13, 14, 16 and 17) unless tests previously made proved one or both of the field coils in bad order. They should be removed only for good reason, as difficulty may be experienced in reassembling so they allow specified armature clearance. When a pole shoe (14) or (16) and field coil (13) or (17) must be removed, clamp generator frame lightly in vise and remove screws (9) or (11) with a large screwdriver as shown in Illus. 89. These screws are very tight and difficulty will be experienced in removing them unless screwdriver bit is in good shape and seats fully in screw slot.



ILLUS. 89  
REMOVING FIELD COILS



## Testing Armature

### To Test for "Ground":

If growler with test points is available, test as shown in Illus. 90. If this means of testing is not available, test with battery and ammeter hook-up, same as used for testing field coils. Contact commutator with one test point and armature core with the other. If circuit is completed, armature is grounded.

If armature is found to be grounded, make sure commutator is free from carbon and copper dust deposits. After cleaning thoroughly between segments and at ends of commutator and blowing off thoroughly with compressed air, repeat test. If ground still exists, armature must be replaced with a new one.

### "Growler" Test for "Short":

Place armature in "growler" and hold piece of hacksaw blade in loose contact with armature core as shown in Illus. 91. Turn "growler" "ON". Rotate armature slowly one or more full turns. If armature is shorted, hacksaw blade will be attracted to armature core and will vibrate violently at one or more points around armature.

If short is found, clean thoroughly between commutator segments as described under "ground" test, and test again. If short still exists, armature must be replaced with a new one.

### "Growler" Test for "Open":

Place armature in "growler" as shown in Illus. 92 and turn "growler" "ON." Insert tip of hacksaw blade between segments that are closest in alignment with the point of contact of armature core and "growler" V. Make and break contact between segments with hacksaw blade.

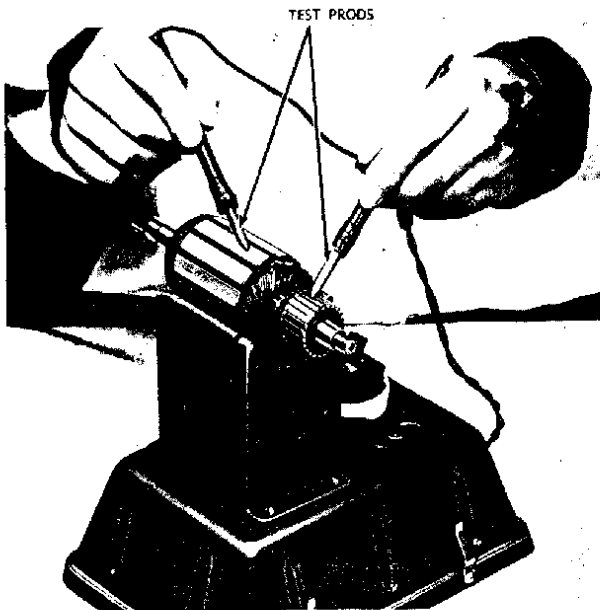

ILLUS. 90  
TESTING ARMATURE FOR "GROUND"

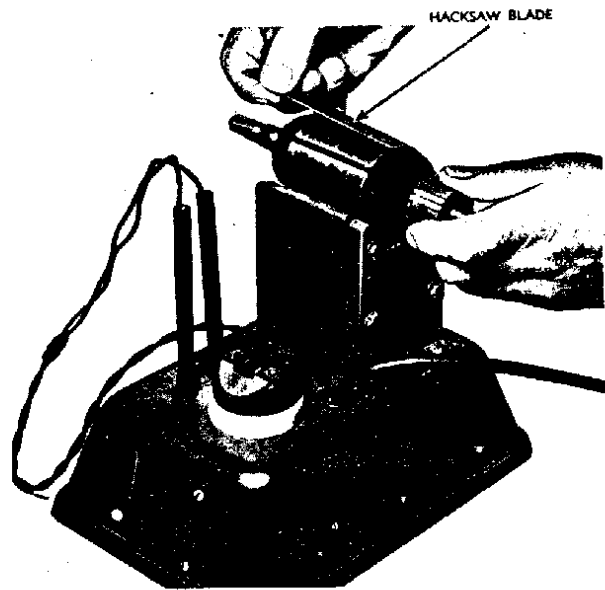

ILLUS. 91  
TESTING ARMATURE FOR "SHORT"

A strong flash should be seen as contact is broken. No flash or a very weak flash indicates an open circuit.

Repeat this test between all segments, turning armature so that each test is made on the line of contact between armature core and "growler" V. If an open circuit is found check for loose or broken wires at commutator connections. If none are found that can be repaired, armature must be replaced with a new one.

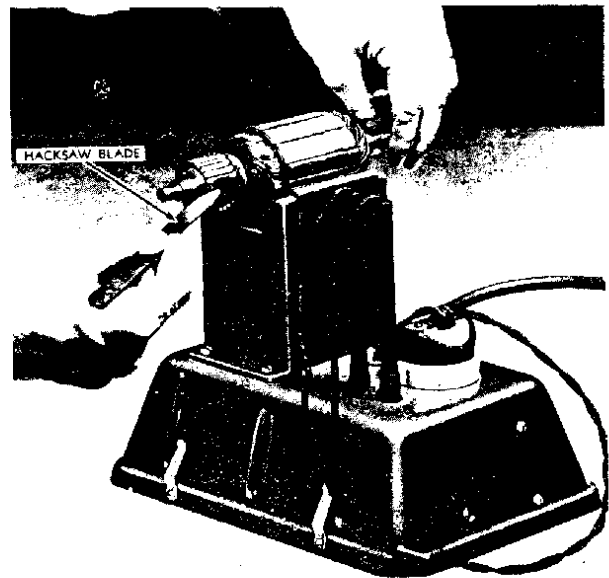

ILLUS. 92  
TESTING ARMATURE FOR "OPEN"



## Turning Down Commutator

If commutator is found worn and irregular, it should be turned down in a lathe and smoothed with No. 00 sandpaper. When turning, mount armature shaft on its bearing seats; do not mount on shaft centers.

## Undercutting Commutator

After commutator has been turned down, the mica insulation between segments must be undercut to a depth of approximately .025". Unless mica is properly undercut, brushes will not seat firmly against commutator segments and generator output will not be normal. Also, there will be excessive arcing at brushes.

Undercutting is usually done with a special undercutting machine. However, if such a machine is not available, it can be done as shown in Illus. 93.

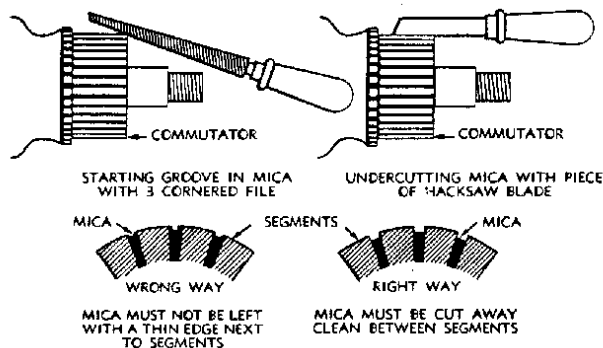

ILLUS. 93  
UNDERCUTTING COMMUTATOR MICA

After undercutting is completed, again smooth commutator with No. 00 sandpaper. It is also advisable to repeat "growler" check for "short" as there is a possibility of developing a "short" during the turning and undercutting operations. If so, it can very likely be corrected by more thorough cleaning between segments and at ends of commutator.

## Reassembling Generator

(To Identify Items, Refer to Illus. 79 or 80)

1. If one or both field coils have to be reassembled, do this first. Remember that field coils (13) and (17) are not alike and must not be interchanged. If one has to be replaced, be sure it is replaced with one of same type.

Thoroughly clean generator frame where pole shoe seats and also clean face of pole shoe that seats against frame. Tighten pole shoe screws (9) and (11) as tight as possible, with a large screwdriver that fits well into screw slot. Unless screws are very tight, there will not be the required clearance (.007" or more) between armature and each pole shoe (this clearance is to be checked later when armature is assembled into frame).

2. Proceed with further assembly of generator,

reversing order of disassembly as outlined under "Disassembling Generator," Page 99.

3. If felt oil retaining washer (7), or oil seal explained in paragraph 11, under "Disassembling Generator," Page 99, is worn, renew it.

4. Thoroughly wash and closely inspect both the drive end and commutator end bearings, (5) and (42). If either is found worn to any extent, or pitted and rough, renew it. The commutator end bearing particularly should be replaced if it shows any appreciable wear, as a loose bearing allows commutator to run eccentric and chatter, even though commutator itself is perfectly true. Pack both bearings with high melting point grease (Harley-Davidson grade "A" grease).

### 5. Gauging Armature Pole Shoe Clearance:

Select a sheet of paper .007" thick or use a double sheet totaling this thickness. Cut a piece as wide as length of armature core and long enough to wrap nearly, but not quite, around armature.

Assemble armature in frame with this paper around it, inserting shaft through drive end bearing. If pole shoe clearance is up to the required .007" or more on each side, armature can be inserted and will turn freely. If it binds, pole shoe or shoes removed and replaced must be pulled tighter to frame with pole shoe screws. Possibly parts were not well cleaned and there are particles of dirt between shoe and frame, preventing full seating.

Specified pole shoe clearance is necessary to allow for expansion of armature when hot and for play that normally develops due to bearing wear. Taking a chance on less than specified clearance may result in armature striking pole shoe and damaging both the armature and pole shoe. An armature damaged in this manner is usually grounded and must be renewed.

6. **Installing Frame End:** Generator frame end fits over register in frame and is located by a dowel pin in frame and a corresponding hole in frame end. Frame end must be a snug fit on frame register or a new end must be installed. If frame end is loose on frame, armature-pole shoe clearance is affected and the likely result is a damaged armature. Tighten screws securely.

7. Complete assembly of generator. Be sure pin that secures drive gear, oil centrifuge or spring collar is well riveted at both ends to prevent it from coming out in service and causing serious damage to timing gears and other parts. *Side Valve Engine only:* Measure the distance from outer face of oil centrifuge on end of armature shaft to end of generator frame (gasket removed). This distance should be 1-53/64" to 1-27/32". Adjust if necessary by removing or adding an armature spacer (18).

Connect field coil wires according to Illus. 96 or 97 and paragraph "2" under "Disassembling Generator," Page 99.

Test generator on test stand if this equipment is available. If not, install on engine and test. Generator output can be adjusted as follows: Three

brush generator—by moving third brush; two brush generator—by adjusting current and voltage regulator. See "Generator Charging Rate."

### Assembling Generator to Engine

Reverse the operations followed in "Removing Generator," Page 97; also refer to "Installing Generator," Page 64.

Make sure same number of paper shims are used in reassembling as were found underneath generator when it was removed. After an engine has seen considerable service and gears have worn to some extent, they have possibly developed enough lash or play to permit safely removing one or more of the original shims and thus effecting closer meshing and quieter operation. However, this should not be done unless timing gear case cover is removed so gear mesh and lash can be carefully checked.

Make sure all external wire connections are correct and tight.

### Generator Charging Rate

(The following maximum rates specified are battery charge over equipment loads indicated, which do not include sidecar lighting, using test ammeter at battery ground.)

#### 1. Standard Generator:

A maximum charging rate of about 4 amperes with standard equipment tail lamp, speedometer light and headlamp lighted (headlamp on upper light beam) is standard factory setting.

#### Radio Three Brush Generator:

A maximum charging rate of about 2 amperes with radio and standard equipment tail lamp, speedometer

light and headlamp lighted (headlamp on upper light beam) is standard factory setting. If motorcycle is used without radio, remove resistor from generator "relay" and "switch" terminals, and adjust charging rate to a maximum of about 4 to 5 amperes with the above standard equipment lamps lighted.

**All Three Brush Generators:** Standard factory setting should be sufficient to keep battery in a good state of charge under normal service conditions. At average driving speeds, the charging rate is about the same with lights either "ON" or "OFF" because when lighting switch is "ON" generator output is automatically boosted enough to take care of the standard lighting equipment. The charging rate can be adjusted higher or lower as desired to meet unusual service conditions, but bear in mind that a higher than normal charging rate is likely to overcharge, overheat and damage battery.

When it is found necessary to adjust charging rate, proceed as follows: Remove generator end cover, and loosen screws that hold the regulating brush (small brush) plate assembly to generator frame end. Then shift regulating brush to the right to increase charging rate—to the left, to decrease charging rate. Shift brush only a little at a time, until desired maximum charging rate is obtained (see Illus. 94).

#### 2. Radio Two Brush Generator:

A maximum charging rate of 11 to 12 amperes (over ignition only) controlled by current and voltage regulator. When battery voltage is low, regulator will limit generator to about 11 to 12 amperes, and after battery voltage is up to normal, regulator will then limit generator to very low charging rate. If regulator does not control generator within specified limits, see "Current and Voltage Regulator," Page 106.

### Inspecting or Replacing Generator Brushes

Remove the two screws in generator end cover and pull off cover, exposing the commutator and brushes. Brushes can be taken out after unfastening spring retainers. To unfasten small (regulating) brush spring retainer, simply press it downward and outward. Remove fastening screw from each of the larger brush spring retainers.

Brushes are worn out and should be renewed when longest side of brush measures  $\frac{3}{8}$ " or less.

Be sure to insert brushes into holders so that concave face of brush fits curve of commutator.

### Cleaning Commutator

Remove footboard, clutch footpedal assembly, and generator end cover. If oil or grease has worked out of bearings and onto commutator, wipe it off first with a rag moistened with gasoline or solvent and then sandpaper until commutator is bright, using No. 00 sandpaper. CAUTION: Never use emery cloth to clean commutator. See "Generator Charging Rate."

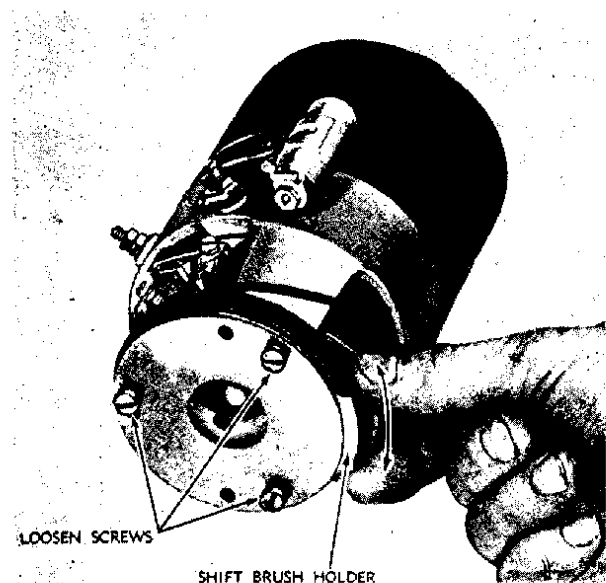

ILLUS. 94

SHIFTING REGULATING (THIRD) BRUSH TO ADJUST CURRENT OUTPUT OF GENERATOR

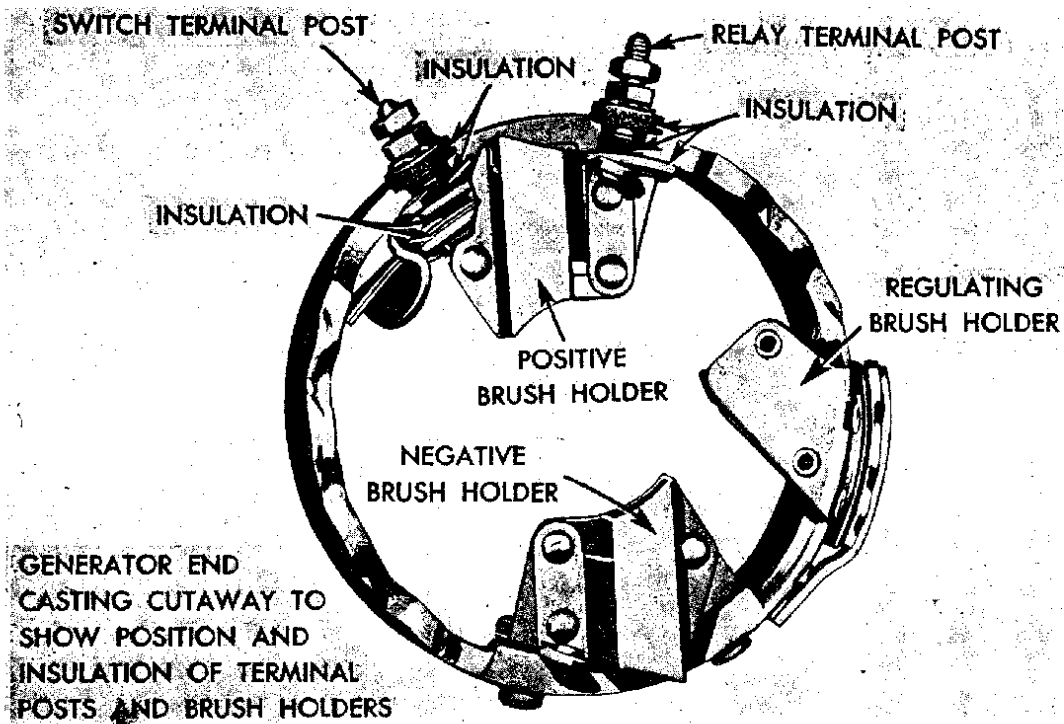

ILLUS. 95  
GENERATOR END SECTION SHOWING TERMINAL AND BRUSH HOLDER INSTALLATION

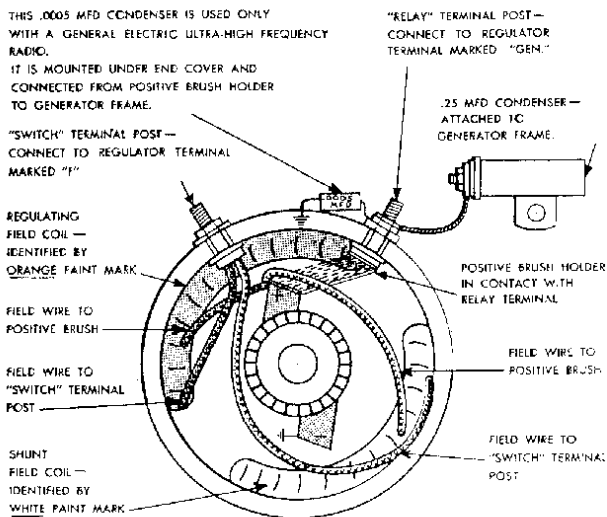

ILLUS. 96

SCHEMATIC DIAGRAM, SHOWING GENERATOR INTERNAL WIRING CONNECTIONS, LOCATION OF FIELD COILS AND BRUSHES IN RELATION TO EXTERNAL CONNECTIONS AND CONDENSER CONNECTIONS (RADIO TWO BRUSH GENERATOR). THIS GENERATOR CAN BE USED ONLY WITH CURRENT AND VOLTAGE REGULATOR

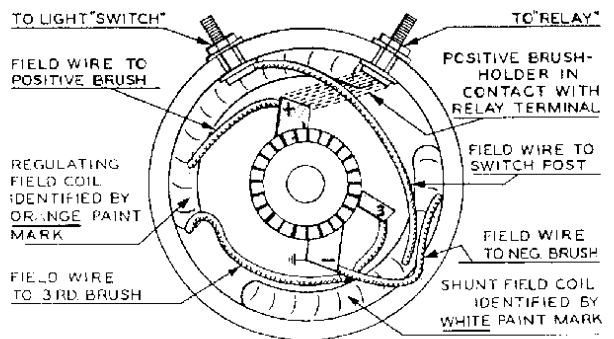

ILLUS. 97

SCHEMATIC DIAGRAM, SHOWING GENERATOR INTERNAL WIRING CONNECTIONS AND LOCATION OF FIELD COILS AND BRUSHES IN RELATION TO EXTERNAL CONNECTIONS (THREE BRUSH GENERATOR). THIS IS THE STANDARD GENERATOR NORMALLY SUPPLIED ON ALL MOTORCYCLES. ALSO APPLIES TO RADIO THREE BRUSH GENERATOR.

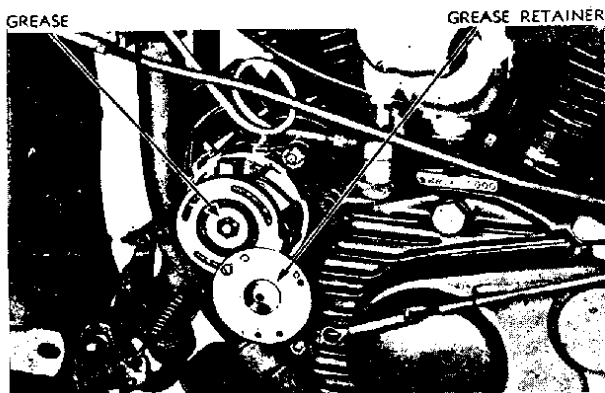

ILLUS. 98  
GREASING COMMUTATOR END ARMATURE BEARING

### Lubricating Commutator End Armature Bearing

(To Identify Items, Refer to Illus. 79 or 80—  
Also Refer to Illus. 98)

To lubricate bearing (42) it is necessary to first remove end cover (54). Then bearing can be oiled through hole in outer grease retainer (52) or outer grease retainer can be shifted to expose bearing and permit greasing as follows:

Take out two of the three outer grease retainer screws (53) and loosen the third screw slightly to permit shifting outer grease retainer to one side. Pack bearing with high melting point grease (Harley-Davidson grade "A" grease). After greasing, replace outer grease retainer. **CAUTION:** If outer grease retainer is completely removed or two of the screws are removed and the third screw is made very loose, regulating brush holder (50) is free to move and thus change charging rate. Therefore, before retightening outer grease retainer screws be sure that regulating brush holder has remained in its original position.

If not convenient to grease bearing at specified interval, at least lubricate with a few drops of engine oil. Be careful that this bearing is not over-lubricated, as excess oil will very likely work out of bearing and some may get onto commutator and brushes.

Generator drive gear end bearing requires no attention as it is lubricated by the oil that circulates through engine.

### Cut-Out Relay

(Refer to Illus. 99)

#### Adjusting Points and Air Gap

The cut-out relay is provided with an additional contact for the normally open position to control the generator signal light in instrument panel. When the generator voltage exceeds battery voltage (between 6.3 and 6.8 volts) the relay closes the battery-generator circuit. At this time, the upper contact points

break and the instrument panel indicator light goes off, indicating that generator is charging the battery. This occurs at approximately 20 miles per hour in high gear.

The relay contact points must be correctly adjusted and the armature must have correct spacing above magnet core for sensitive and correct cut-in and cut-out operation.

**Armature and core air gap:** The space (air gap) between the armature and magnet core end should be .015" when the two upper points are in contact. Bend upper contact point support and adjust armature to obtain this gap.

**Main contact point gap:** After armature and magnet core end air gap have been adjusted, gauge the main contact point gap. It should be .020" and can be obtained by bending the lower point support up or down as may be necessary.

**Signal light point gap:** Press the armature down until the lower main points are in contact and gauge the upper contact point gap. It should be .020" and can be obtained by bending the upper point support up or down as necessary.

**Adjusting armature spring tension:** The relay main lower points should close at 6.3 to 6.8 volts (connect voltmeter to relay terminal marked "GEN" and to the relay base), and can be adjusted by decreasing or increasing the armature spring tension. Increasing spring tension increases the closing voltage—decreasing spring tension reduces closing voltage. The armature spring tension is altered by bending the spring stop, mounted on top of magnet, up or down.

#### Testing Cut-Out Relay

If it has been determined that point setting and air gap are correct and relay does not function, test as follows:

With relay removed from motorcycle, and using a 110 volt test lamp, place one test point on "GEN" terminal of relay and other test point on relay base. If lamp does not light, it indicates an open circuit in shunt (voltage) coil which will prevent contact points from closing.

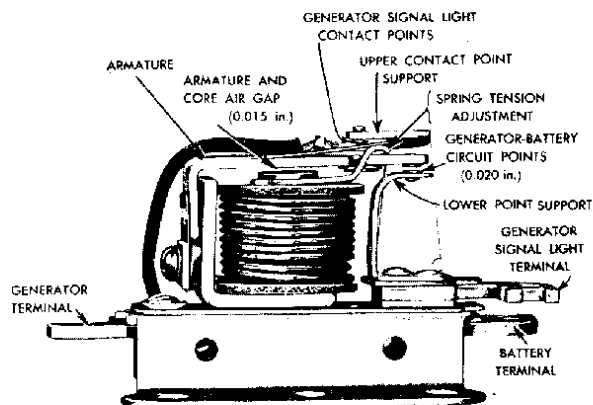

ILLUS. 99  
CUT-OUT RELAY



With one test point on "GEN" terminal, and other test point on relay armature, test lamp should light. If it does not, it indicates an open circuit in series (current) coil.

If relay passes above tests, and generator is known to be O.K., but points do not close, it is an indication that series coil is grounded, or voltage coil grounded prematurely.

It is not practical to disassemble relay for repairs. A relay worn or damaged beyond adjustment service should be replaced.

Cut-out relay must be grounded; therefore, mounting screws must be tight.

## Current and Voltage Regulator

A current and voltage regulator is an electrical device that controls generator output, and is used with two brush generator only. Generator cut-out relay, current regulator unit and voltage regulator unit are all mounted on one base.

It is a special regulator as concerns its adjustment for proper regulation of a Harley-Davidson generator. Therefore, a regulator adjusted for an automobile generator cannot be used for regulation of a Harley-Davidson generator, otherwise serious damage to generator will very likely result.

The regulator is properly adjusted at factory when manufactured. Unauthorized persons must never tamper with adjustments as special equipment is required to properly adjust regulator. Under ordinary circumstances regulator will need very little attention in service.

If, however, regulator does need attention it should be referred to United Motor Service (located in many cities throughout the U.S.A.) who is authorized to service Delco-Remy regulators.

The following checks can be made to determine whether or not the units are operating normally. If not, the checks will indicate whether the generator or regulator is at fault, so that proper corrective steps may be taken.

Connect an ammeter between battery positive (left) terminal and regulator terminal marked "BAT".

Fully charged battery and a low charging rate indicates that regulator has reduced output, as it should when operating properly.

Fully charged battery and a high charging rate indicates that regulator is failing to reduce output as it should; due either to a faulty regulator or generator.

High charging rate to a fully charged battery causes battery to gas and overheat, also produces high voltage in the electrical system which may cause armature, coil, breaker point and lamp bulb failure.

To determine if regulator is at fault, disconnect "F" terminal lead at regulator to open generator field circuit. If charge rate drops to zero trouble has been isolated in regulator.

If charging rate continues, generator field circuit is grounded internally, or in wiring harness.

A low battery and a low or no generator charging rate indicates a high resistance in charging circuit, or regulator or generator is faulty.

Check wiring for loose connections or frayed or damaged wires. High resistance resulting from these conditions will prevent normal charge from reaching battery. If wiring is in good condition, then regulator or generator is at fault.

Ground "F" terminal of regulator temporarily and increase generator speed. Avoid excessive speed for any length of time as generator output may be dangerously high and damage to generator may result.

1. If generator output does increase, regulator needs attention.

2. If generator output remains low with "F" terminal grounded, generator is at fault and should be checked further.

3. If generator does not show any output either with or without "F" terminal grounded, disconnect wire from "GEN" terminal of regulator and strike it against a convenient ground with generator operating at medium speed. If a spark does occur, cut-out relay is not functioning to permit current to flow to battery. If no spark occurs, generator is at fault and will need further attention. See "When Generator Fails to Charge," Page 96.

**CAUTION:** It is advisable to "flash" field coils whenever wires have been removed from generator or regulator; or after generator or battery has been removed and is reinstalled. This is done to make sure generator has correct polarity. If polarity of generator is reversed, relay points will vibrate and burn. "Flash" field coils by momentarily touching a jumper wire between "BAT" terminal and "GEN" terminal on regulator, after all wires have been properly connected and before starting engine. The momentary surge of current from battery to generator will correctly polarize generator.

## Care of Storage Battery

It is the care given a battery, rather than time and miles in service, that has most to do with determining its life. Don't neglect it.

1. Inspect battery every week. Add pure distilled water as often as necessary to keep solution above the plates. See "Adding Water to Battery," Page 107.

2. Remove battery and have it given a charge from an outside source, when the hydrometer shows that this attention is needed. Allowing battery to remain in a discharged condition for any length of time shortens its life. A fully charged battery has a specific gravity reading of 1.275 or above; a discharged battery has a specific gravity reading of about 1.150.

It is especially important that battery be kept well charged in below freezing weather as a low or discharged battery is very likely to be frozen and ruined.

3. Keep battery clean, and terminal connections



tight. Oil the terminal felt washers frequently and replace immediately if deteriorated or lost.

### **Battery Constant Charge Rate 2 Amperes**

When charging a battery from an outside source, the charging rate is constant and should not be allowed to go over 2 amperes. A higher rate will heat and damage the battery. **CAUTION**—Therefore, don't allow battery to be charged in the same line with automobile batteries, at a high charge rate or allow battery to be charged on a "quick" charger.

### **Adding Water to Battery**

Motorcycle should be standing straight up, not leaning on jiffy stand, when adding water to battery.

Turn off wing nuts, and remove battery cover and rubber mat. Take out the three screw-in filler plugs, and with a hydrometer or syringe add enough water to each cell to raise the level of the solution about 5/16" above the plates and separators.

**CAUTION:** If battery is filled to a higher level, some of the solution will be forced out through vent holes when battery is charging. This not only weakens battery solution but also damages parts near battery.

### **Ignition Coil**

When hard starting or missing indicates some fault in the ignition system, the first thing to do is check condition of battery. Coil will not function normally with battery in a nearly discharged condition. If it is found that lamps light with full brilliancy and horn blows, indicating that battery is in at least fair condition, try new spark plugs. If new plugs do not correct performance, inspect circuit breaker points and install new condenser. If the fault still exists, try a new coil without removing old coil. Simply attach new coil temporarily at any convenient point near old coil (coil will function without being securely grounded), transfer terminal wires to new coil, and after detaching old coil plug cables from spark plugs, attach new coil cables.

If new coil corrects performance, proving that the fault is in the old coil, inspect plug cables for cracked or damaged insulation, particularly at sealing nuts where cables enter coil. The insulation on cables sometimes becomes cracked or otherwise damaged, allowing high tension current to short to metal parts with which cables come in contact. Trouble due to this condition is most noticeable when operating in wet weather or just after motorcycle has been washed.

Replacing plug cables is the only repair that can be made to an ignition coil. If faulty performance is not corrected by installing new cables, coil is beyond repair and must be replaced with a new one.

### **Replacing Spark Plug Cables (Standard Type Coil)**

When inspection indicates that coil trouble is very likely due to faulty condition of plug cables, they

can be replaced as follows: Warm coil slightly to soften sealing compound so old cables can be pulled out easily, and without breakage. The usual way to warm a coil is to flow current through it by either turning "ON" ignition switch, or connecting a battery to coil terminals. This generates heat in coil winding. Have new cables ready to be inserted immediately when old cables are pulled out. New cable ends that insert into coil should be trimmed and rounded so they will follow through the holes left in sealing compound by old cable without catching and jamming. After coil is warm (not hot) turn off cable seal nuts and pull out cables one at a time. As each cable is pulled out, quickly transfer nut, steel washer and rubber packing washer to new cable. Insert a piece of stiff wire into coil and measure the distance from coil end to cable seat. Mark new cable accordingly. Dip end of cable in very light oil or gasoline and push into coil. Be sure it is pushed all the way into its seat as per mark made on cable. After cables are inserted, turn seal nuts down against rubber packing washers to secure cables and to prevent water from getting inside coil.

When replacing plug cables do not heat coil to a higher degree than just warm as doing so will soften sealing compound to the extent that cable holes through compound will close up as the old cables are pulled out, blocking the insertion of new cables. In this case it is necessary to allow coil to cool and then form new cable holes by means of a piece of tubing with saw teeth filed in one end. Tubing should be of slightly larger diameter than cable. Holes through compound must be open so cables can be inserted all the way to their seats, where they contact high tension winding terminals; otherwise there is a gap in the high tension circuit and coil will not function.

### **Replacing Spark Plug Cables (Radio Type Coil)**

Metallic shielding must be removed before removing plug cables. Plug cables are installed in coil in the same manner as standard plug cables. Metallic shielding is to be installed as follows: Push shielding over plug cable until coupling nut engages threaded bushing on coil and tighten nut securely. The opposite end of metallic shielding has a flanged end and a knurled nut. Measuring from edge of flange, the plug cable should protrude exactly one inch. If wire extends more than one inch, cut off surplus (no trimming or removal of insulation on end of cable is necessary; merely cut wire to required length).

Attach bakelite insulator to end of shielding by inserting protruding end of plug cable into hole in insulator and then pushing insulator toward coupling nut. A pin centrally located in insulator will contact plug cable wire as insulator is assembled to cable. Tighten coupling nut securely. Shielded cable assembly is now ready for assembly to spark plug.

## SPARK PLUGS

1. After a new engine has gone through its running-in period, colder than the original plugs may be needed, especially as concerns O.H.V. Models. The type of plug required depends on compression ratio and how hard engine is driven. This cannot be determined by compression ratio alone, as some high compression engines see very moderate service, and some low compression engines are driven very hard.

2. If, in an engine in average good condition as concerns valve seating, compression, timing, etc., plugs after a short time in service are found with cores blistered, cracked or partially burned away, this indicates the need of either a richer high speed carburetor adjustment or colder plugs. If plugs are found with an accumulation of oily soot or carbon, and possibly fouling difficulty is experienced, this indicates the need of either reduced oil supply or hotter plugs.

In some cases best results may be found using a colder plug in one cylinder than in the other. In this case it is usually the front cylinder that takes the colder plug as this cylinder is not as likely to foul plug at low speed. Here's the thing to bear in mind: The colder the plug that can be used without running into fouling difficulties and hard starting, the longer plug life will be and the less chance

there is of engine failure and damage from pre-ignition and overheating.

3. The core tip of a plug in hot service will in time, possibly only a short time, acquire a brownish, glassy coating. This oxide coating is a conductor when hot, and will cause missing at high speed or under heavy engine load. Plugs should be cleaned regularly to remove this coating.

4. Do not take plugs apart to clean nor try to save a few cents by installing new core only when a plug has to be renewed. Reassembling without proper equipment for adjusting and testing, runs into a high percentage of failures due to leakage and core cracking. These things very often contribute to serious engine trouble.

The recommended method of cleaning is with a sand-blast cleaner found in nearly every service station.

5. Correct plug gap is .025" to .030". Since gap increases slowly with use due to gradual burning away of electrodes, plugs should be checked and reset occasionally. When regapping, adjust only the base electrode, as bending center electrode will break porcelain core. For high speed service it is well to adjust gap to low limit (.025").

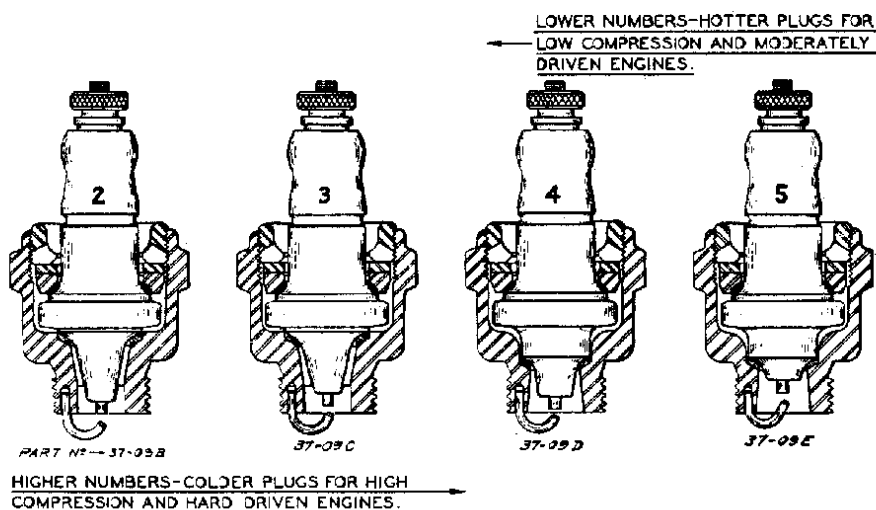

ILLUS. 100

HARLEY-DAVIDSON SPARK PLUG IDENTIFICATION—PLUGS SECTIONED TO SHOW CORE CONSTRUCTION

## IGNITION-LIGHT SWITCH ASSEMBLY

1946 and Earlier Models  
(Item Numbers Refer to Illus. 101)

ITEM	NUMBER USED	PART NUMBER	NAME
1	1	2764-30	Switch Key (specify letter and number of lock)
2	1	4529-36A	Switch cover
3	1	4548-36	Switch Lock
4	1	4536-36	Switch Housing
5	1	4554-36	Switch Lock Plate
6	1	4543-36	Center Pin
7	1	.....	Contact Bar Holder Assembly
8	1	.....	Reinforcing Plate
9	1	4539-36	Contact Plate
10	1	4541-36	Contact Bar
11	.....	4527-36	Ignition-Light Switch Assembly (shown as assembled for 1946 and earlier Models). 1947 Model switch is assembled same as 1946 and earlier Model switch, except contact plate, Item (9). See paragraph 4 under "Servicing Ignition-Light Switch", Page 110.

Footnote: To maintain interchangeability with earlier switches (not originally fitted with Item 8), Items 7 and 8 are not furnished separately.

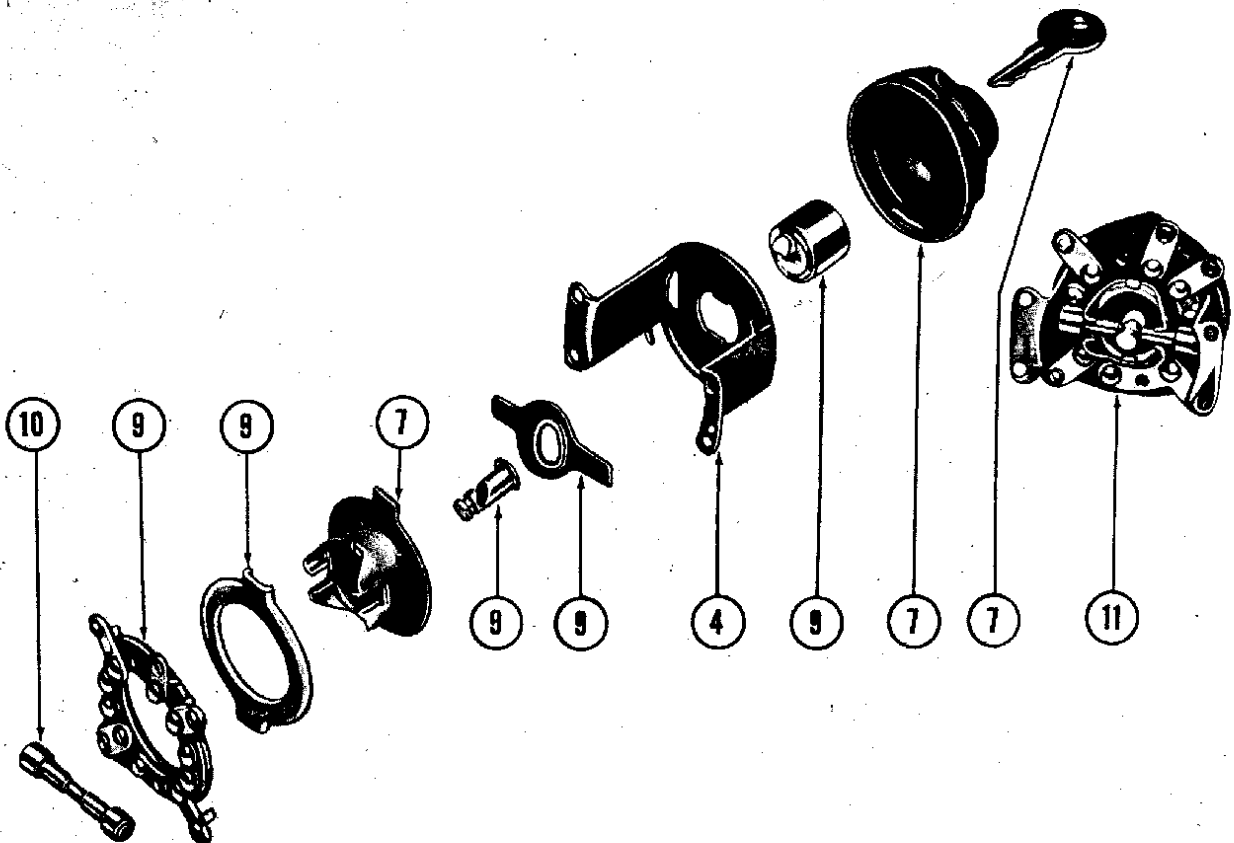

ILLUS. 101  
IGNITION-LIGHT SWITCH DISASSEMBLED

## Servicing Ignition-Light Switch

(To identify items, Refer to Illus. 101)

See Item 24, under Illus. 102, 103 and 105 for information on switch operating positions.

1. After removing instrument panel cover, disconnecting wires and removing switch from panel, a faulty switch can be disassembled for inspection and repair as follows:

2. All switch part positions mentioned below apply with switch upsidedown. Switch must be in "OFF" position and unlocked.

3. Grasp end of center pin (6) with pliers and pull and move sideways to release contact bar (10) from retaining notch in center pin.

4. After contact bar has been released and removed, contact plate (9) with five terminals attached can be removed.

*1946 and Earlier Model Switch:* Note that contact plate is installed with the three terminals toward lock cover hinge.

*1947 Model Switch:* Note that contact plate is installed with the two terminals toward lock cover hinge.

5. Contact bar holder assembly (7) with reinforcing plate (8) and center pin (6) can now be removed from switch cover by sliding either one of the plate extensions out of retaining slot in switch housing (2) and then sliding opposite extension out of other slot.

6. Switch frame (4) and lock plate (5) can now be removed from switch cover. Note that narrow end of elongated hole in lock plate, and also lug on switch lock (3) which fits into hole in lock plate, are toward lock cover hinge.

7. Lock assembly can now be lifted out of switch cover. Avoid separating lock tumbler assembly from its housing.

8. Inspect switch parts, particularly contact bar and contact plate, for excessive wear of contact bar and contact buttons or otherwise faulty condition. Contact bar and contact buttons may be found worn to the point where they no longer make positive contact. Extreme wear of these parts may allow head of center pin to "short" against switch lock plate. Loosened terminals on stationery contact plate may also develop a "short."

9. Install new parts for any found worn or damaged. Scrape off any rust that may be found on head of center pin, apply a light coat of oil or grease to head of pin and lock plate, contact bar and contact buttons and proceed with reassembly, reversing order of disassembly.

10. Bear in mind that if lock tumbler assembly has been taken out of its housing, it must be reinstalled in correct position in relation to housing. Otherwise, it will be found after switch is completely reassembled, that switch can not be locked. To reassemble correctly, insert lock tumbler assembly

into its housing with tumblers in any one of the four registers. While pressing tumbler assembly into its housing with finger tip, insert key and turn as far to right as possible. Remove key.

## Horn

Horn operating (ground) button is on left handlebar. Tone adjusting screw is in back side of horn.

If a horn fails to operate and moving adjusting screw does not remedy the trouble, it will probably be necessary to disassemble horn and clean contact points.

When reassembling, tighten all bolts securely and then readjust tone by means of adjusting screw. Do not change position of adjusting screw in diaphragm.

## Adjusting Headlamp

To get the greatest efficiency from headlamp and to meet the requirements of law, adjust as follows: Adjustment should be made in a darkened room or at night. Have motorcycle standing on a level surface about 25 feet away from, and headed toward a wall or screen upon which a horizontal line has been drawn at exactly the same height as lamp center. Motorcycle must be resting on both wheels and front wheel must be in straight-ahead alignment.

Turn light switch "ON" set headlamp dimming switch (on handlebar) in high beam position, and check light beam for height and direction. The top of main beam of light should register on wall or screen even with, but no higher than, the horizontal line mentioned. After loosening the clamp nut underneath lamp bracket, lamp can be tilted up or down to properly aim it in relation to horizontal line, and at the same time can be turned right or left to direct beam of light straight ahead.





## Wiring Diagram With Current and Voltage Regulator—1946 and Earlier Models

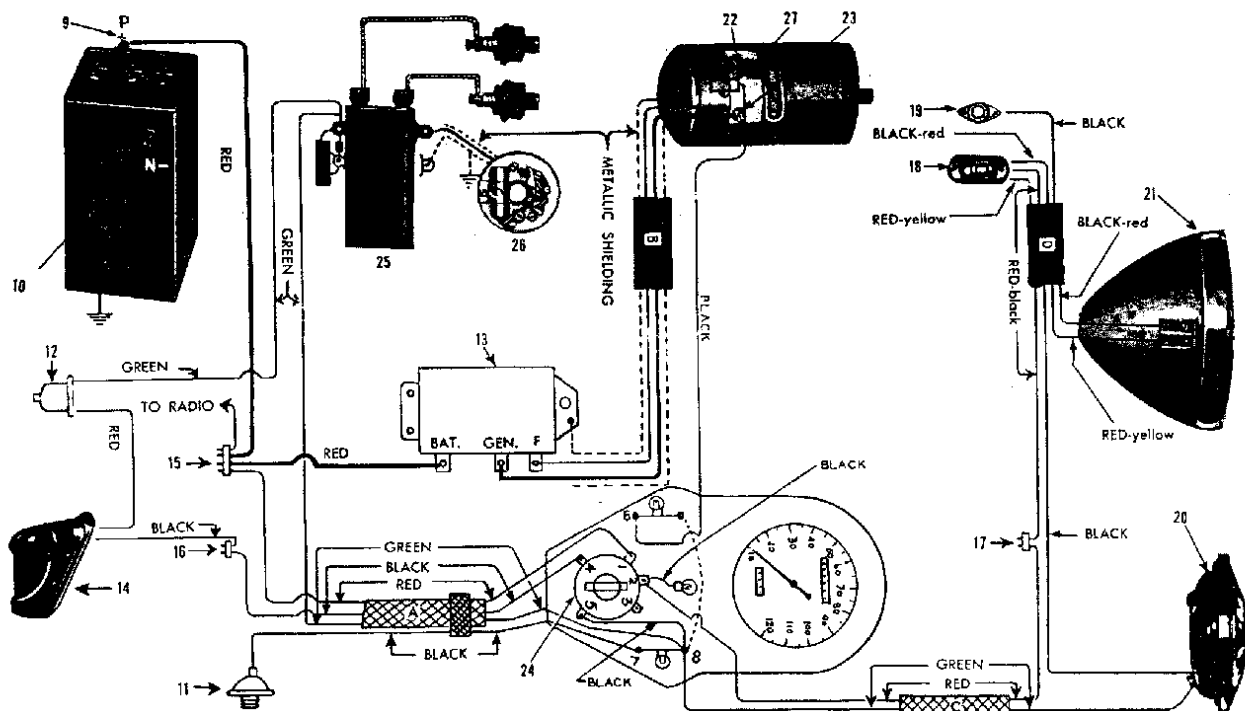

ILLUS. 102

### Description of Cables

A. THREE WIRE CABLE (fourth wire attached)—Green wire; red wire; two black wires.

B. LOOM COVERED METALLIC SHIELDED CABLE (two wires)—No standard color.

C. TWO WIRE CABLE—Green wire; red wire.

D. LOOM (four wires)—Black wire with red tracer; red wire with yellow tracer; red wire with black tracer; black wire.

### Connections

1. SWITCH TERMINAL—Cable "A" red wire, from junction terminal (15).

2. SWITCH TERMINAL—Cable "C" red wire, from junction terminal (17); black wire from speedometer light switch.

3. SWITCH TERMINAL—Terminal for use of parking lamps, etc., independent of headlamp—if desired to use with headlamp, connect to terminal (2).

4. SWITCH TERMINAL—Cable "A" black wire, from junction terminal (16).

5. SWITCH TERMINAL—Black wire from junction terminal (8).

6. GENERATOR SIGNAL LIGHT TERMINAL—Black wire from generator "relay" terminal (23).

7. OIL PRESSURE SIGNAL LIGHT TERMINAL—Black wire from oil pressure signal switch (11).

8. JUNCTION TERMINAL—Black wire (underneath switch panel) from generator signal light contact; black wire from switch terminal (5); cable "A" green wire, from coil front upper terminal; cable "C" green wire, from horn (20).

9. BATTERY POSITIVE TERMINAL (left side)—Red wire from junction terminal (15).

10. BATTERY NEGATIVE TERMINAL (right side)—Black wire from ground terminal on frame.

11. OIL PRESSURE SIGNAL SWITCH—Black wire from junction terminal (7).

12. STOP LAMP SWITCH—Red wire from tail and stop lamp (14); green wire from coil front upper terminal.

13. CURRENT-VOLTAGE REGULATOR—Cable "B" wire from generator "switch" terminal (22) to regulator terminal marked "F"; cable "B" wire from generator "relay" terminal (23) to regulator terminal marked "GEN"; red wire from junction terminal (15) to regulator terminal marked "BAT"; cable "B" metallic shielding connected to regulator base and generator cover.

14. TAIL AND STOP LAMP—Red wire from stop lamp switch (12); black wire from junction terminal (16).

15. JUNCTION TERMINAL (in right side of motorcycle frame under saddle)—Cable "A" red wire, from switch terminal (1); red wire from regulator terminal marked "BAT"; red wire from battery positive terminal (9); wire from radio receiver.

16. JUNCTION TERMINAL (in left side of motorcycle frame under saddle)—Cable "A" black wire, from switch terminal (4); black wire from tail and stop lamp (14).

17. JUNCTION TERMINAL (on horn mounting)—Cable "C" red wire, from switch terminal (2); red wire with black tracer from handlebar toggle switch (18).

18. HANDLEBAR TOGGLE SWITCH—Black wire with red tracer from headlamp larger terminal screw; red wire with yellow tracer from headlamp smaller terminal screw; red wire with black tracer from junction terminal (17).

19. HORN SWITCH—Black wire from horn (20).

20. HORN—Cable "C" green wire, from terminal (8); black wire from horn switch (19).

21. HEADLAMP—Black wire with red tracer from handlebar toggle switch (18) to larger terminal screw; red wire with yellow tracer from handlebar toggle switch (18) to smaller terminal screw. Note: Headlamp is shown in upside down position.

22. GENERATOR ("SWITCH") TERMINAL—Cable "B" wire, from regulator terminal marked "F."

(Continued on next page)

23. GENERATOR ("RELAY") TERMINAL—Cable "B" wire, from regulator terminal marked "GEN"; black wire from junction terminal (6); wire from condenser (27).

24. IGNITION-LIGHT SWITCH (top view)—Switch is "OFF" when switch lock cover hinge is directly forward. Turn left for parking with lights (see explanation under "SWITCH TERMINAL" (3), concerning attaching front parking lamps). Turn to first right position for ignition only—second right position for ignition and running lights. Bear in mind that lighting headlamp when engine is dead also turns ignition "ON."

Switch is provided with lock and key to permit locking, if desired, when motorcycle is not in use. It can be locked in "OFF" and "PARK" positions only. When switch is unlocked and motorcycle is in use, key should be removed from lock.

25. IGNITION COIL—Cable "A" green wire, from junction terminal (8) to coil front upper terminal; green wire from stop lamp

switch (12) to coil front upper terminal. Condenser mounting bracket connected to coil front lower (ground) terminal—condenser terminal connected to coil front upper terminal by a metal strip. Mica condenser connected between coil front lower (ground) terminal and coil front upper terminal. Black wire (low tension wire) from circuit breaker (26) to coil rear upper terminal; low tension wire metallic shielding to coil rear lower (ground) terminal.

26. IGNITION CIRCUIT BREAKER—Black wire (low tension wire) from coil rear upper terminal; low tension wire metallic shielding: O.H.V. Models—connected under crankcase stud nut (upper center nut); Side Valve Models—connected under oil feed pump mounting nut (upper right nut).

27. CONDENSER—Attached to generator frame. Condenser terminal connected to generator "relay" terminal (23) by short wire. Note: Earlier models have condenser attached to generator end cover.

## Wiring Diagram: Without Current and Voltage Regulator—1946 and Earlier Models

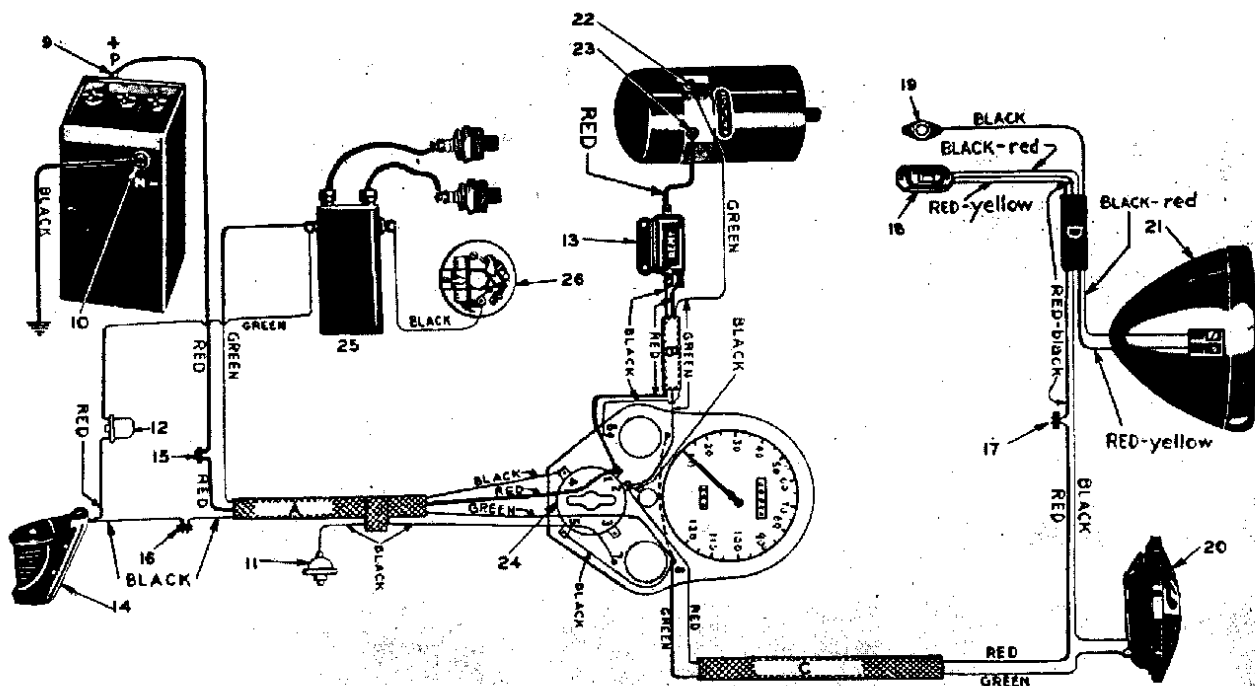

ILLUS. 103

### Description of Cables

- A. THREE WIRE CABLE (fourth wire attached)—Green wire; red wire; two black wires.
- B. THREE WIRE CABLE—Green wire; red wire; black wire.
- C. TWO WIRE CABLE—Green wire; red wire.
- D. LOOM (four wires)—Black wire with red tracer; red wire with yellow tracer; red wire with black tracer; black wire.

### Connections

1. SWITCH TERMINAL—Cable "A" red wire from junction terminal (15); cable "B" red wire from relay (13) (terminal marked "BAT").
2. SWITCH TERMINAL—Cable "C" red wire from junction terminal (17); cable "B" green wire from generator "switch" terminal (22); black wire from speedometer light switch.
3. SWITCH TERMINAL—Terminal for use of parking lamps, etc., independent of headlamp—if desired to use with headlamp, connect to terminal (2).
4. SWITCH TERMINAL—Cable "A" black wire from junction terminal (16).
5. SWITCH TERMINAL—Black wire from junction terminal (8).
6. GENERATOR SIGNAL LIGHT TERMINAL—Cable "B" black wire from relay (13).
7. OIL PRESSURE SIGNAL LIGHT TERMINAL—Black wire from oil pressure signal switch (11).
8. JUNCTION TERMINAL—Black wire (underneath switch panel) from generator signal light contact; black wire from switch terminal (5); cable "A" green wire from coil (25) (front terminal); cable "C" green wire from horn (20).
9. BATTERY POSITIVE TERMINAL (left side)—Red wire from junction terminal (15).
10. BATTERY NEGATIVE TERMINAL (right side)—Black wire from ground terminal on frame.
11. OIL PRESSURE SIGNAL SWITCH—Black wire from junction terminal (7).
12. STOP LAMP SWITCH—Red wire from tail and stop lamp (14); green wire from coil front terminal.
13. RELAY—Cable "B" red wire from switch terminal (1) to relay terminal marked "BAT"; cable "E" black wire from junction terminal (6); red wire from generator "relay" terminal (23).
14. TAIL AND STOP LAMP—Red wire from stop lamp switch (12); black wire from junction terminal (16).

15. JUNCTION TERMINAL (in right side of motorcycle frame under saddle)—Cable "A" red wire from switch terminal (1); red wire from battery positive terminal (9).

16. JUNCTION TERMINAL (in left side of motorcycle frame under saddle)—Cable "A" black wire from switch terminal (4); black wire from tail and stop lamp (14).

17. JUNCTION TERMINAL (on horn mounting)—Cable "C" red wire from switch terminal (2); red wire with black tracer from handlebar toggle switch (18).

18. HANDLEBAR TOGGLE SWITCH—Black wire with red tracer from headlamp larger terminal screw; red wire with yellow tracer from headlamp smaller terminal screw; red wire with black tracer from junction terminal (17).

19. HORN SWITCH—Black wire from horn (20).

20. HORN—Cable "C" green wire from junction terminal (8); black wire from horn switch (19).

21. HEADLAMP—Black wire with red tracer from handlebar toggle switch (18) to larger terminal screw; red wire with yellow tracer from handlebar toggle switch (18) to smaller terminal screw. Note: Headlamp is shown in upside down position.

22. GENERATOR ("SWITCH") TERMINAL—Cable "B" green wire from switch terminal (2).

23. GENERATOR ("RELAY") TERMINAL—Red wire from relay terminal.

24. IGNITION-LIGHT SWITCH (top view)—Switch is "OFF" when switch lock cover hinge is directly forward. Turn left for parking with lights (see explanation under "SWITCH TERMINAL" (3), concerning attaching front parking lamps). Turn to first right position for ignition only—second right position for ignition and running lights. Bear in mind that lighting headlamp when engine is dead also turns ignition "ON."

Switch is provided with lock and key to permit locking, if desired, when motorcycle is not in use. It can be locked in "OFF" and "PARK" position only. When switch is unlocked and motorcycle is in use, key should be removed from lock.

25. IGNITION COIL—Cable "A" green wire from junction terminal (8) to coil front terminal; green wire from stop lamp switch (12) to coil front terminal. Black wire (low tension) wire from circuit breaker (26) to coil rear terminal.

26. IGNITION CIRCUIT BREAKER—Black wire (low tension wire) from coil rear terminal.

## Wiring Diagram: Generator-battery; Ignition; Horn; Generator and Oiling System Signal Lights and Stop Lamp—1947 Models

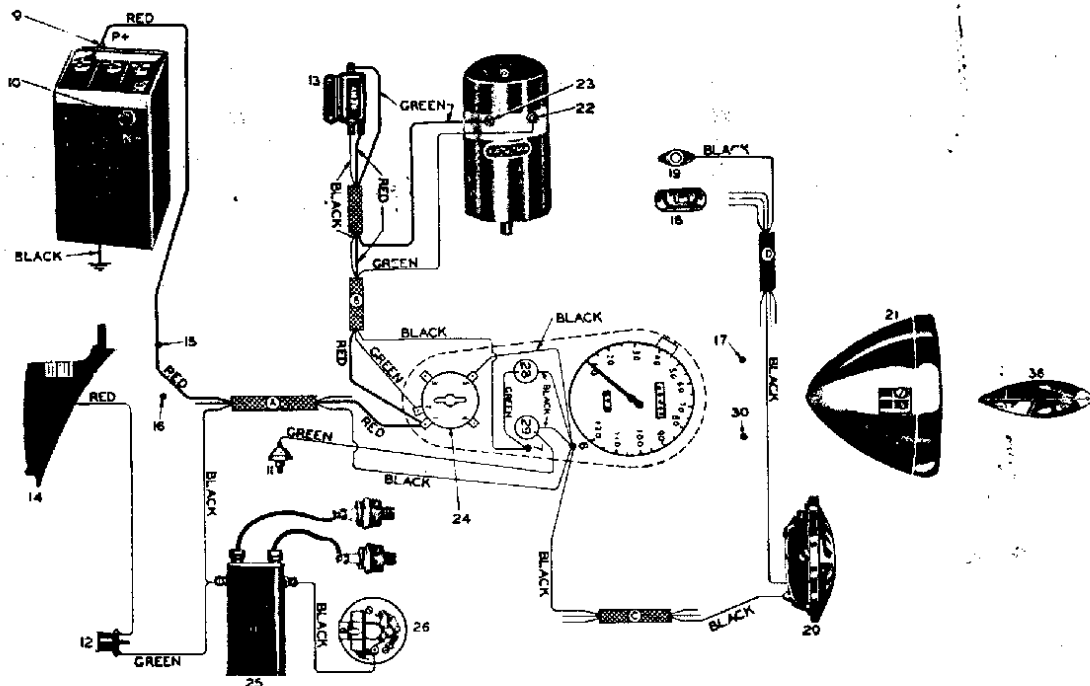

ILLUS. 104

### Description of Cables

- A. THREE WIRE CABLE—Green wire; red wire; black wire.
- B. THREE WIRE CABLE—Green wire; red wire; black wire.
- C. THREE WIRE CABLE—Green wire; red wire; black wire.
- D. LOOM (four wires)—Black wire with red tracer; red wire with yellow tracer; red wire with black tracer; black wire.

### Connections

1. SWITCH TERMINAL—Cable "A" red wire from junction terminal (15); cable "B" red wire from relay (13) (terminal marked "BAT").
2. SWITCH TERMINAL—Cable "B" green wire from generator "switch" terminal (22).
5. SWITCH TERMINAL—Black wire from junction terminal (6).
6. JUNCTION TERMINAL—Cable "C" black wire from horn (20); black wire from oil signal light (29); black wire from generator signal light (28); black wire from switch terminal (5); cable "A" black wire from coil front terminal.
7. JUNCTION TERMINAL—Cable "B" black wire from relay (13); green wire from generator signal light (28).
9. BATTERY POSITIVE TERMINAL (left side)—Red wire from junction terminal (15).
10. BATTERY NEGATIVE TERMINAL (right side)—Black wire from ground terminal on frame.
11. OIL PRESSURE SIGNAL SWITCH—Green wire from oil signal light (29).
12. STOP LAMP SWITCH—Red wire from tail and stop lamp (14); green wire from coil front terminal.
13. RELAY—Cable "B" red wire from switch terminal (1) to

relay terminal marked "BAT"; cable "B" black wire from junction terminal (7); green wire from generator "relay" terminal (23).

14. TAIL AND STOP LAMP—Red wire from stop lamp switch (12).
15. JUNCTION TERMINAL (in right side of motorcycle frame under saddle)—Cable "A" red wire from switch terminal (1); red wire from battery positive terminal (9).
19. HORN SWITCH—Loom "D" black wire from horn (20).
20. HORN—Loom "D" black wire from horn switch (19); cable "C" black wire from junction terminal (6).
22. GENERATOR ("SWITCH") TERMINAL—Cable "B" green wire from switch terminal (2).
23. GENERATOR ("RELAY") TERMINAL—Green wire from relay (13).
24. IGNITION-LIGHT SWITCH (top view)—switch is "OFF" when switch lock cover hinge is directly forward. Turn to first right position for ignition only. Switch is provided with lock and key to permit locking, if desired, when motorcycle is not in use. It can be locked in "OFF" and "PARK" positions only. When switch is unlocked and motorcycle is in use, key should be removed from lock.
25. IGNITION COIL—Cable "A" black wire from junction terminal (6); green wire from stop lamp switch (12); black wire (low tension wire) from circuit breaker (25).
26. IGNITION CIRCUIT BREAKER—Black wire (low tension wire) from coil rear terminal.
28. GENERATOR SIGNAL LIGHT (marked "GEN")—Black wire from junction terminal (6); green wire from junction terminal (7).
29. OIL PRESSURE SIGNAL LIGHT (marked "OIL")—Green wire from oil pressure signal switch (11); black wire from junction terminal (6).





## Wiring Diagram: Generator-current and Voltage Regulator-battery; Speedometer Hand Lock; Police Pursuit Lamps and Radio Type Coil—1947 Models

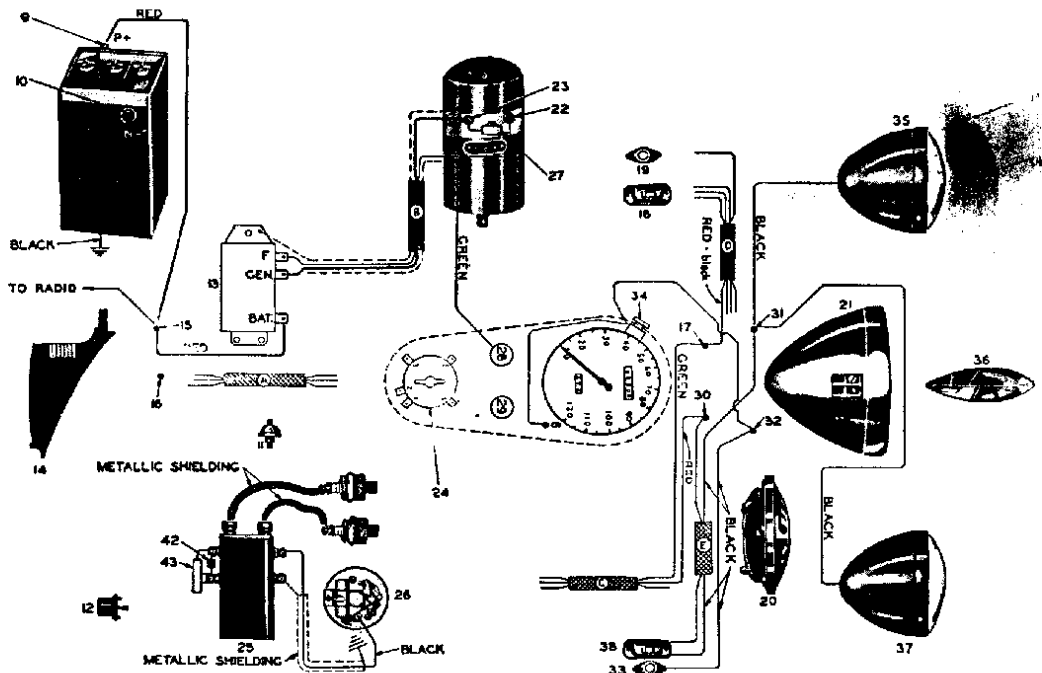

ILLUS. 106

### Description of Cables

**B. LOOM COVERED METALLIC SHIELDED CABLE** (two wires)  
—No standard color.

**C. THREE WIRE CABLE**—Green wire; red wire; black wire.

**D. LOOM** (four wires)—Black wire with red tracer; red wire with yellow tracer; red wire with black tracer; black wire.

**E. THREE WIRE CABLE** (clamped on outside of right handlebar)  
—Green wire; red wire; black wire. Red wire not used—ends of wire cut off.

### Connections

**6. JUNCTION TERMINAL**—Wire from speedometer hand lock (34).

**9. BATTERY POSITIVE TERMINAL** (left side)—Red wire from junction terminal (15).

**10. BATTERY NEGATIVE TERMINAL** (right side)—Black wire from ground terminal on frame.

**13. CURRENT AND VOLTAGE REGULATOR**—Cable "B" wire from generator "switch" terminal (22) to regulator terminal marked "F"; cable "B" wire from generator "relay" terminal (23) to regulator terminal marked "GEN"; red wire from junction terminal (15) to regulator terminal marked "BAT"; cable "B" metallic shielding connected to regulator base and generator cover.

**15. JUNCTION TERMINAL** (in right side of motorcycle frame under saddle)—Red wire from battery positive terminal (9); red wire from regulator terminal marked "BAT"; wire from radio receiver.

**17. JUNCTION TERMINAL** (front terminal—left side, in headlamp bracket)—Cable "C" green wire; loom "D" red wire with black tracer.

**22. GENERATOR ("SWITCH") TERMINAL**—Cable "B" wire from regulator terminal marked "F."

**23. GENERATOR ("RELAY") TERMINAL**—Cable "B" wire from regulator terminal marked "GEN"; green wire from generator signal light (28); wire from condenser (27).

**25. IGNITION COIL**—Black wire (low tension wire) from circuit breaker (29) to coil rear upper terminal; low tension wire metallic shielding to coil rear lower (ground) terminal; condenser (43)

mounting bracket connected to coil front lower (ground) terminal—condenser terminal connected to coil front upper terminal by metal strip; mica condenser (42) connected between coil front lower (ground) terminal and coil front upper terminal.

**26. IGNITION CIRCUIT BREAKER**—Black wire (low tension wire) from coil rear upper terminal; low tension wire metallic shielding; O.H.V. Models—connected under crankcase stud nut (upper center nut); Side Valve Models—Connected under oil feed pump mounting nut (upper right nut).

**27. CONDENSER**—Attached to generator frame. Condenser terminal connected to generator "relay" terminal (23) by short wire.

**28. GENERATOR SIGNAL LIGHT** (marked "GEN")—Green wire from generator "relay" terminal (23).

**30. JUNCTION TERMINAL** (front terminal—right side, in headlamp bracket)—Cable "C" red wire; cable "E" green wire from handlebar toggle switch (38).

**31. JUNCTION TERMINAL** (side terminal—left side, in headlamp bracket)—Cable "E" black wire from handlebar toggle switch (38); black wires from pursuit lamps (35) and (37).

**32. JUNCTION TERMINAL** (side terminal—right side, in headlamp bracket)—Wire from speedometer hand lock (34); wire from speedometer hand lock switch (33).

**33. SPEEDOMETER HAND LOCK SWITCH**—Black wire from junction terminal (32).

**34. SPEEDOMETER HAND LOCK**—Wire from junction terminal (6); wire from junction terminal (32).

**35. PURSUIT LAMP**—Black wire from junction terminal (31).

**37. PURSUIT LAMP**—Black wire from junction terminal (31).

**38. HANDLEBAR TOGGLE SWITCH**—Cable "E" green wire from junction terminal (30); cable "E" black wire from junction terminal (31).

**42. MICA CONDENSER**—Connected between coil front lower (ground) terminal and coil front upper terminal.

**43. CONDENSER**—Condenser mounting bracket connected to coil front lower (ground) terminal, and condenser terminal connected to coil front upper terminal by a metal strip.

## Wiring Diagram: Lighting System Accessory Lamps (does not apply to Police Pursuit Lamps)—1947 Models.

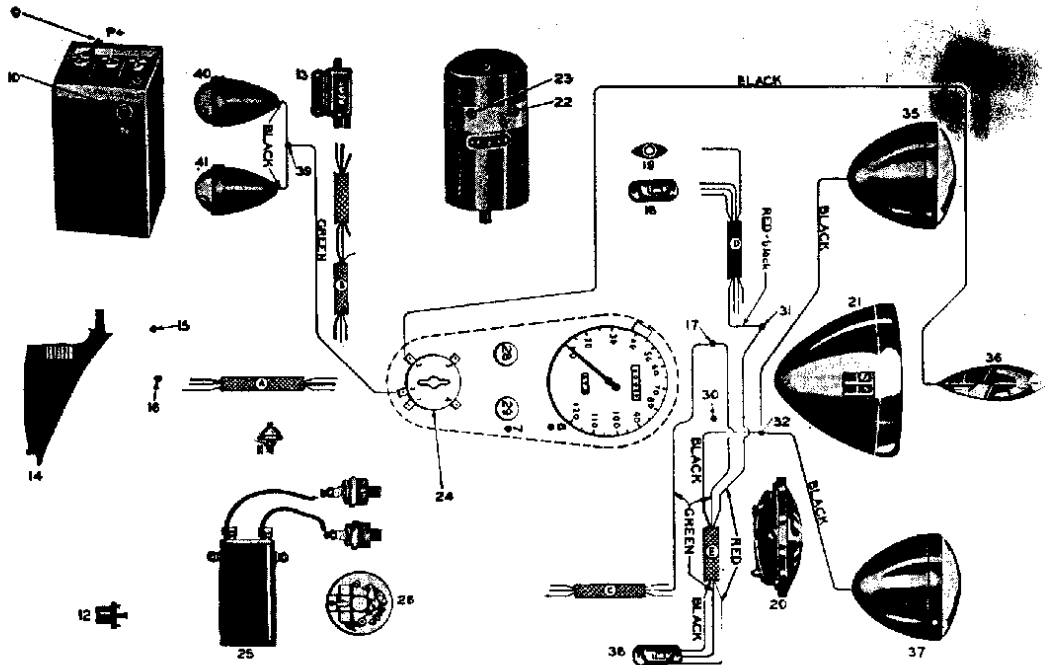

ILLUS. 107

Note: With this method of wiring, when spotlamps are turned "ON," headlamp is automatically turned "OFF" and vice-versa.

### Description of Cables

- C. THREE WIRE CABLE—Green wire; red wire; black wire.
- D. LOOM (four wires)—Black wire with red tracer; red wire with yellow tracer; red wire with black tracer; black wire.
- E. THREE WIRE CABLE (clamped on outside of right handlebar)—Green wire; red wire; black wire.

### Connections

- 2. SWITCH TERMINAL—Green wire from junction terminal (39).
- 3. SWITCH TERMINAL—Black wire from mudguard lamp (36).
- 17. JUNCTION TERMINAL (front terminal—left side, in headlamp bracket)—Cable "C" green wire; Cable "E" green wire from handlebar toggle switch (38). Note: Loom "D" red wire with black tracer is connected to this terminal for Standard Equipment Lighting System, but when installing spotlamps, it is disconnected from this terminal and reconnected to junction terminal (31).
- 31. JUNCTION TERMINAL (side terminal—left side, in headlamp bracket)—Cable "E" red wire from toggle switch (38); loom "D" red wire with black tracer.
- 32. JUNCTION TERMINAL (side terminal—right side, in headlamp bracket)—Black wires from spotlamps (35) and (37); Cable "E" black wire from toggle switch (38).
- 35. SPOTLAMP—Black wire from junction terminal (32).
- 36. MUDGUARD LAMP—Black wire from switch terminal (3).
- 37. SPOTLAMP—Black wire from junction terminal (32).
- 38. HANDLEBAR TOGGLE SWITCH (clamped to right bar)—Cable "E" red wire from junction terminal (31); Cable "E" green wire from junction terminal (17); Cable "E" black wire from junction terminal (32).
- 39. JUNCTION TERMINAL (in saddle bar—right side)—Green wire from switch terminal (2); black wires from saddle lamps (40) and (41).
- 40. SADDLE LAMP—Black wire from junction terminal (39).
- 41. SADDLE LAMP—Black wire from junction terminal (39).

## O. H. V. AND SIDE VALVE ENGINE CARBURETOR ASSEMBLIES

ITEM	NUMBER USED	PART NUMBER		NAME
		O.H.V. ENGINE	S.V. ENGINE	
1	1	1231-36	.....	Choke Lever (integral with choke shaft)
1	1	.....	1233-33A	Choke Lever (carburetor with air cleaner)
1	1	.....	1233-33	Choke Lever (carburetor without air cleaner)
2	1	1254-40	1254-27	High Speed Needle
3	1	1261-27A	1261-27A	Low Speed Needle
4	1	032	032	Throttle Lever Lock Screw
5	1	1238-40	1238-37	Throttle Lever
6	1	024	024	Throttle Stop Screw
7	1	011	011	Lock Screw (locks throttle stop screw)
8	.....	.....	.....	Carburetor Bowl Vent (drilled in body casting)
9	1	1292-27	1292-27	Low Speed Needle Lift Lever
10	1	1232-24	1232-24	Choke Disc

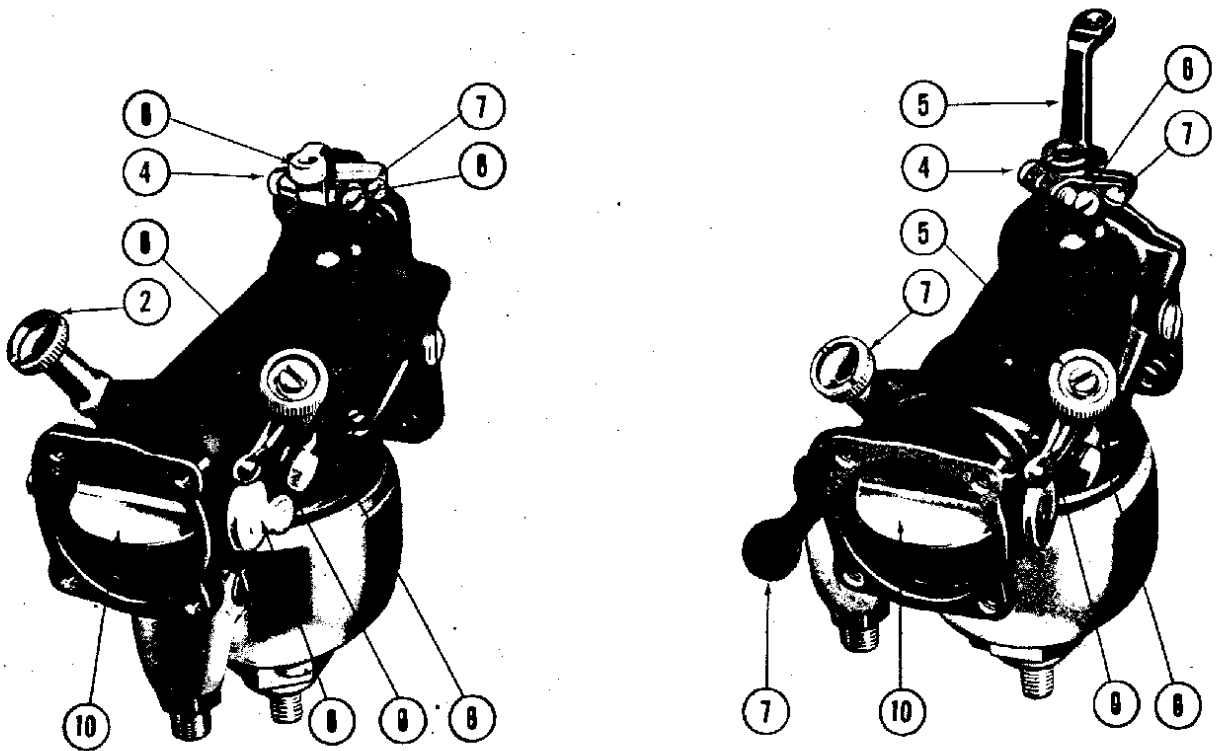

ILLUS. 108

O.H.V. AND SIDE VALVE MODEL CARBURETOR ASSEMBLIES

## SERVICING CARBURETOR

(To Identify Items, Refer to Illus. 106, 109, 110, 111 and 112)

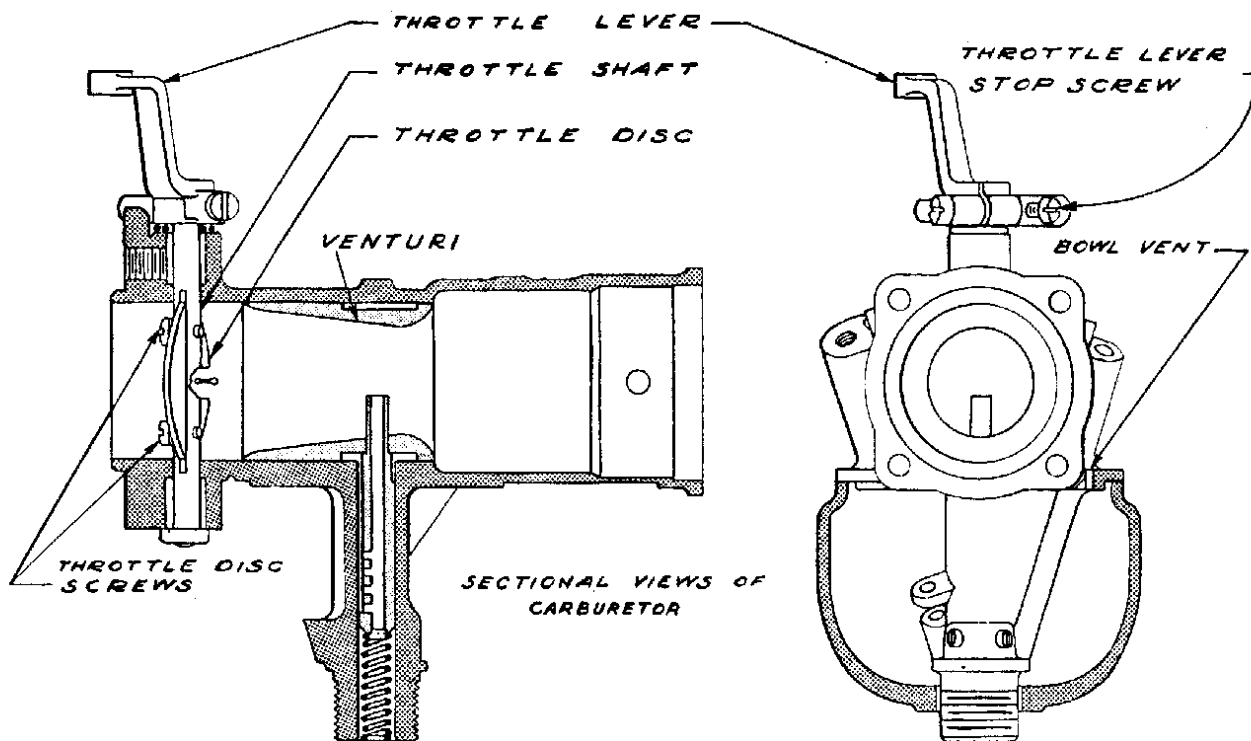

ILLUS. 109

### Effect of Crust Formation

These notes apply to carburetors which have been in service for some time and have become dirty, full of "crust" in the throttle barrel, and are found to be difficult to get adjusted properly. Usually the effect of excessive dirt or "crust" formation in the carburetor throttle barrel, around the throttle disc and in the fuel mixture passageways, is to cause the carburetor to have a lean spot off idle. This "crust" should be removed, particularly when a lean spot comes in at speeds off idle up to approximately 30 M.P.H. with the low speed (idle) adjustment set properly for idling. Idle adjustment should not be set to the very lean side when checking this point, but to a point about five to ten notches rich from the setting where the engine dies from leanness.

### How to Remove Crust

1. Back off throttle lever stop screw (6) so throttle disc closes tightly. With a sharp pointed tool like a sharp pen knife or scribe, scratch a line deeply on closed throttle disc and also on wall of throttle barrel so lines on disc and on barrel meet. The lines scratched on disc and barrel must "line up" again when disc is replaced. Remove throttle lever (5), throttle disc and shaft, idle hole body plug next to idle holes in throttle barrel, body plugs in carburetor flange and carburetor body idle channels, and low speed (idle) lift lever (9) and needle valve assembly.

Also remove venturi and nozzle.

2. Scrape out caking or "crust" in throttle barrel with a scraper or knife, being sure not to cut into the metal. This "crust" can easily be wiped out with a rag dipped in acetone.

3. Clean up throttle disc by rubbing both sides on fine emery cloth on a flat plate and clean edge of disc all around, being careful not to round the corners or cut into the metal. Can be cleaned with acetone.

4. Clean out idle holes in throttle barrel next to the disc with correct size drills of Harley-Davidson clean-up tool kit Part No. 12012-38. Tool kit includes all drills and slot cleaners required for carburetors, but does not include tools for disassembling and assembling carburetors. Correct sizes for both holes are listed in "Carburetor Specifications", Page 125.

5. Clean the connecting slot between the large and small idle holes by inserting tool blade of correct thickness through slot. Tool with .009" blade (for M-51 and M-51L carburetors) has plain handle; tool with .0155" blade (for M-25 and M-35 carburetors) has two rings around its handle; tool with .020" blade (for M-75 carburetor) has three rings around its handle. Widths of slots are listed in "Carburetor Specifications," Page 125.

6. Clean out idle channels with the #42 drill. When cleaning vertical idle channel do not com-

pletely bottom drill as doing so may damage low speed needle seat.

7. Clean out low speed (idle) needle valve seat hole with correct size drill. The M-25, M-51 and M-51L carburetors are cleaned with the #53L drill. The M-35 and M-75 are cleaned with the #53L #2 drill which has a smaller handle. (This tool has two rings around its handle).

8. Blow out all channels and holes with compressed air and wash all parts in gasoline or solvent.

### Attention to Carburetor Bowl

9. If carburetor bowl continually leaks, remove it from carburetor body, noting location of bowl fuel line nipple in relation to carburetor body. Remove all dirt with gasoline and compressed air. Hold bowl upsidedown so that float valve closes and suck on bottom of float valve seat. Valve and seat should hold this suction. If valve and seat leak after repeated testing, replace with new float valve and float valve seat.

10. If float is damaged or logged, replace with a new one. Remove old float after cutting cement seal around float screw which secures float to float lever. This seal can be cut with a pocket knife. Remove float screw and assemble new float to lever. This should be done with float valve, float valve lever, float hinge pin and screws, float valve seat and gasket assembled in bowl. Before tightening float screw securely, adjust as follows: Looking at bowl with gasoline inlet side away from you, pull float toward you to the limit of slot in float lever and about 1/16" to left of center line as shown in Illus. 110. This provides necessary body clearance.

Tighten float screw and cement top of float screw to float with Dupont Household Cement, with mixture of celluloid dissolved in acetone, or with thick shellac. When cement has dried thoroughly, check float height and adjust as explained in paragraph 11.

11. Check float level and, if necessary, reset to 1/4" (see Illus. 110). Measure directly opposite float lever with bowl held upsidedown (top of float to top of bowl). When readjusting carburetor float, do not attempt to do so by simply bending float lever upward in some manner, without disassembling from bowl. Adjusting in this manner bends and spreads fingers between which head of float needle fits, and thus develops lost motion between float and needle. Float and lever assembly should be removed from bowl, and lever then bent as required.

Before reassembling, see that needle head is a good free fit between float lever fingers with not more than approximately .003" play. This clearance can also be checked after lever is assembled in bowl, by carefully placing a small screw driver or a small rod against the valve head in such a position that it will hold the valve firmly against the seat and yet not bind the lever. Moving the lever up and down will then show the amount of actual clearance between the valve head and fingers. If this clearance is excessive, the float mechanism will not feed properly. After assembling note that float is approximately square with top of bowl.

12. Bowl drain plug can be removed for quick flushing of bowl. Before removing this plug, turn off gasoline at tank. Be sure to pull this screw up tight when replacing.

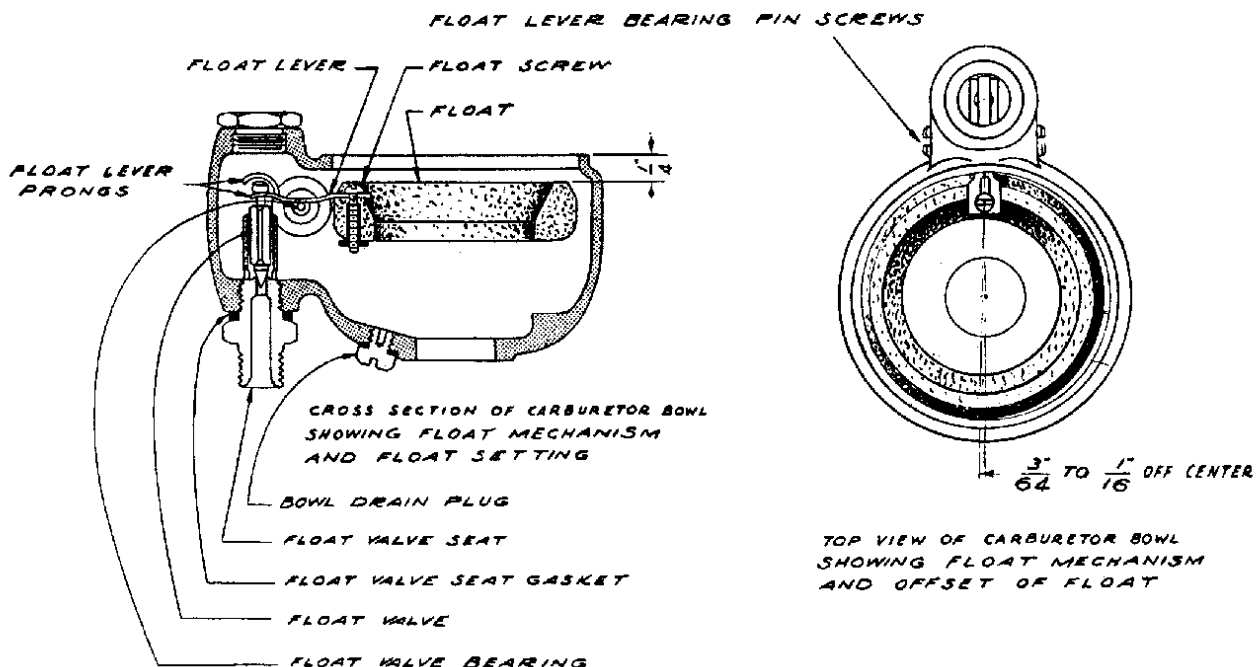

ILLUS. 110



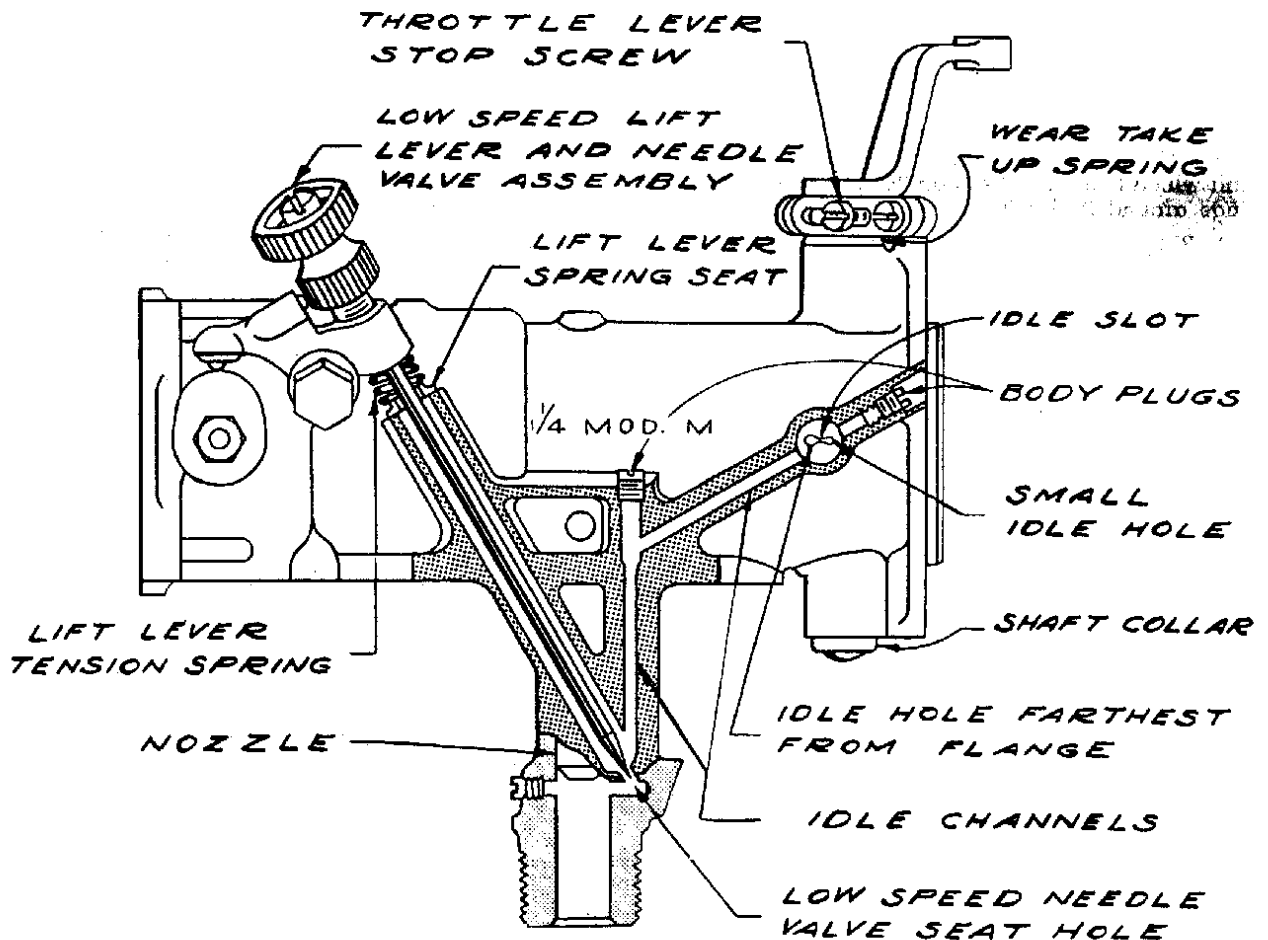

**VIEW OF CARBURETOR**  
**SHOWING LOW SPEED NEEDLE VALVE,**  
**LIFT LEVER SPRING SEAT, LOW SPEED**  
**NEEDLE VALVE SEAT HOLE, IDLE HOLES**  
**AND SLOT, BODY PLUGS, AND IDLE CHANNELS**

ILLUS. 111

### Assembling Carburetor

13. Install all channel opening plug screws.  
Install venturi with choke end (small end) facing air intake opening, and insert spray nozzle through body channel and venturi, as shown in Illus. 109. Spray nozzle is retained by spring and bowl nut.
14. Install spray nozzle retaining spring in body hole, locate bowl assembly on body, (O.H.V. Model carburetor only—install bowl gasket between bowl and body) install copper washer, and turn on bowl retaining nut. See that bowl fuel line nipple is in correct position and tighten bowl nut.
15. Install throttle shaft and pass throttle disc through shaft slot so that counterbored screw holes in shaft and the scribed mark on disc face the manifold end of carburetor body. Install throttle disc re-

taining screws but don't tighten them as yet. Close the throttle disc making sure scribed mark on disc lines up with scribed mark in barrel (if new disc is installed disregard this), and collar on lower end of throttle shaft is tight against carburetor body. Hold throttle shaft and disc snugly in this position and tighten disc retaining screws. Try opening and closing throttle disc to see that it does not bind, and also closes off the barrel hole completely. Install throttle shaft wear take-up spring on shaft and install throttle lever. Open throttle disc wide open in the barrel and clamp throttle lever on the shaft with wide open stop against body stop. Throttle lever and shaft should open and close with just slight drag.

Occasionally throttle shaft and throttle shaft bushings may need renewing. When renewing bush-

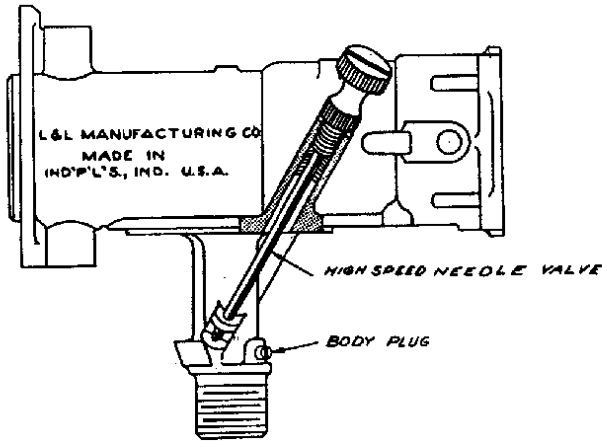

VIEW OF CARBURETOR SHOWING HIGH SPEED NEEDLE VALVE AND ONE BODY PLUG.

ILLUS. 112

ings, use Harley-Davidson special tool set, Part No. 12012-44D. Complete instructions for renewing bushings are included with tool set. See Illus. 113, 114, 115 and 116.

Throttle disc renewal is not usually necessary. If found worn or damaged to the extent of requiring renewal, be sure to install a new one with the same identification number stamped in face of disc. To identify disc see "Carburetor Specifications", Page 125. With disc correctly installed and in closed position, number will be seen through manifold end of carburetor and will be on the opposite side of carburetor from small idle holes.

16. Install choke shaft, with stop notch ball located on end of spring and hold ball in place with choke lever (bottom notch)—Side Valve Model, or stop plate (bottom notch—O.H.V. Model. While holding ball in position, pass choke shaft through body holes (with highest point of cam upward) and enter end of shaft in choke lever, or stop plate. Secure choke lever with lock screw, or stop plate with nut and washer. Install choke disc in shaft slot with hole at bottom of barrel. Close choke, line up screw holes and install and tighten disc retaining screws.

17. After installing low speed needle in lift lever, locate the tension spring and lift lever spring seat (washer with shoulder) on needle with washer shoulder toward spring. Engage needle in body channel and press on lifter lever assembly to compress spring so pivot screw can be installed. Be careful not to bend needle when compressing spring.

**CAUTION:** The lift lever spring seat hole is calibrated and limits the amount of air bleed to idle circuit and must be in place; otherwise carburetor cannot be adjusted for satisfactory engine idling.

18. Install high speed needle.

A few military and police motorcycles are equipped with a carburetor having a fixed high speed adjustment instead of an adjustable needle. One

of the body screw plugs is replaced with a jet plug having an accurately calibrated hole. The "dummy" high speed needle is tightened against its seat and all fuel enters through hole in jet plug.

## Carburetor Adjustments Provided

(To Identify Items, Refer to Illus. 108)

Carburetor is provided with three adjustments as follows:

1. Low speed needle (3) adjustment controls idling and low speed fuel mixture.
2. High speed needle (2) adjustment controls high speed fuel mixture.
3. Throttle lever stop screw (6) adjustment controls idling speed.

Low speed needle (3) is mounted on a lever which is actuated by a cam on end of choke shaft. By means of this arrangement, when choke lever is in any position other than open, needle is lifted (degree of lift depends on position of choke lever) away from its seat enriching the mixture. When choke lever is in open position, needle is in normal running position.

After a carburetor has been apart for clean-up service, readjust it according to instructions applying to carburetor that is badly out of adjustment (see "Adjusting Carburetor," Page 21).

## Memoranda

---

---

---

---

---

---

---

---

---

---

---

---

---

---

---

---

---

---

---

---

---

---

---

---

## Replacing Throttle Shaft Bushings

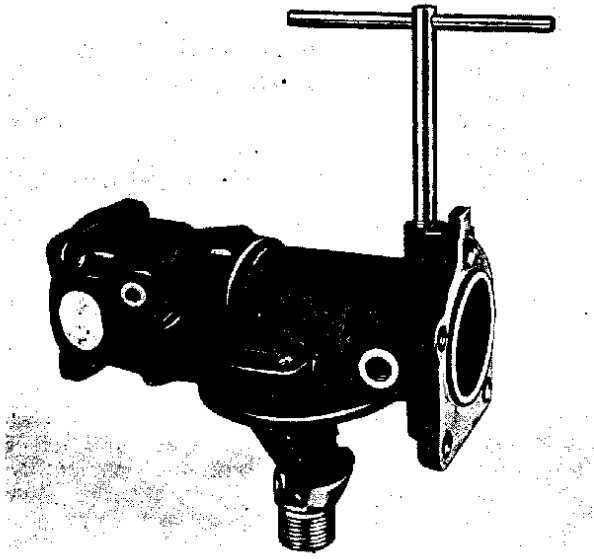

ILLUS. 113  
DRIVE-OUT TAP TURNED INTO WORN THROTTLE  
SHAFT BUSHING

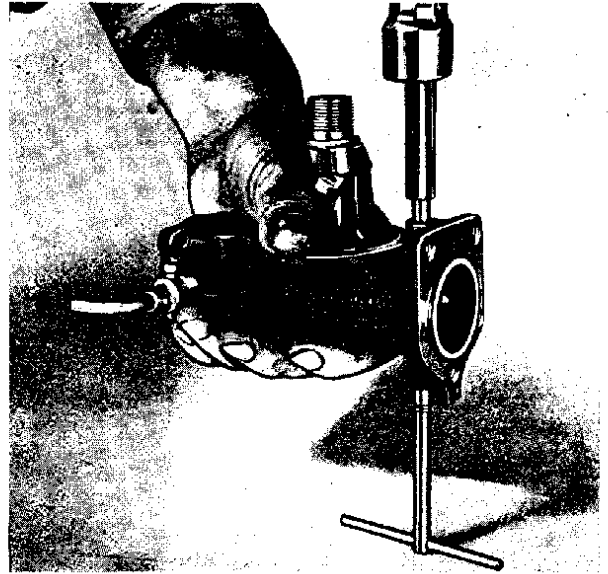

ILLUS. 114  
DRIVING OUT WORN BUSHING

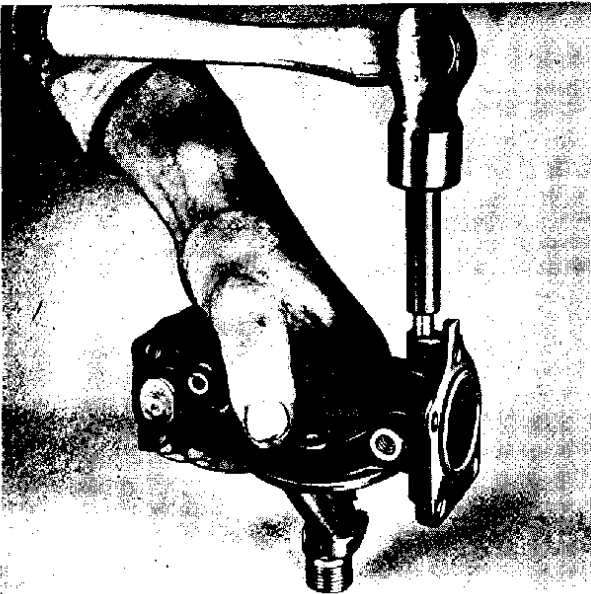

ILLUS. 115  
DRIVING IN NEW BUSHING

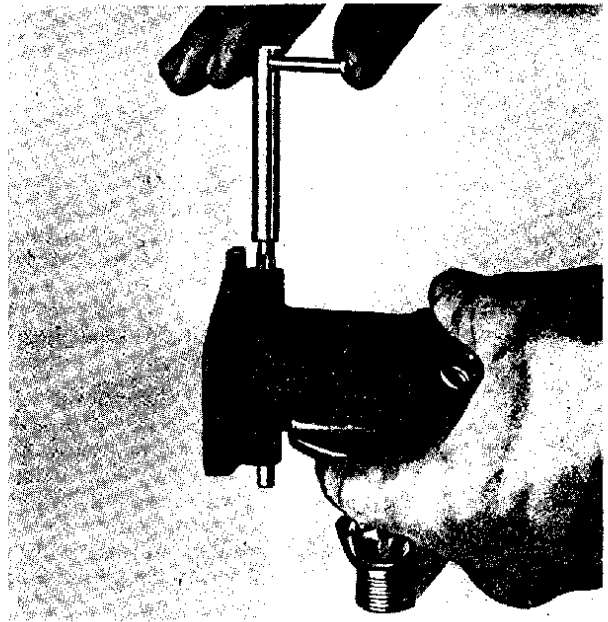

ILLUS. 116  
LINE REAMING BUSHINGS

Note: Instructions for renewing throttle shaft bushings are included with Harley-Davidson special tool set, Part No. 12012-44D.

## CARBURETOR SPECIFICATIONS

Part No.	Model (Stamped in Top of Carb. Body)	Venturi Size	Small Idle Hole Nearest Manifold Flange (Drill Size)	Idle Hole Farthest From Manifold Flange (Drill Size)	Slot Width	Throttle Disc Angle	Where Used
1134-40	M-25	1 $\frac{5}{16}$ "	#55	#55	.0155"	12°	1940 E and EL Models; 1941 F and FL Models; 1942 to 1947 F and FL models (optional) supersedes M-25
	M-75	1 $\frac{5}{16}$ "	#55	#55	.020"	9°	
1134-40A	M-35	1 $\frac{1}{8}$ "	#72	#55	.0155"	12°	1941 to 1947 E and EL models; 1942 to 1947 F and FL models—(standard)
1134-37	M-51	1 $\frac{1}{16}$ "	#70	#55	.009"	13°	1937 to 1947 U and UL models
1134-37A	M-51L	1 $\frac{1}{8}$ "	#70	#55	.009"	13°	1937 to 1941 UH and ULH models

### Memoranda

---



---



---



---



---



---



---



---



---



---



---



---



---



---



---



---



---



---



---



---



---



---

## OVERHAULING TRANSMISSION AND CLUTCH

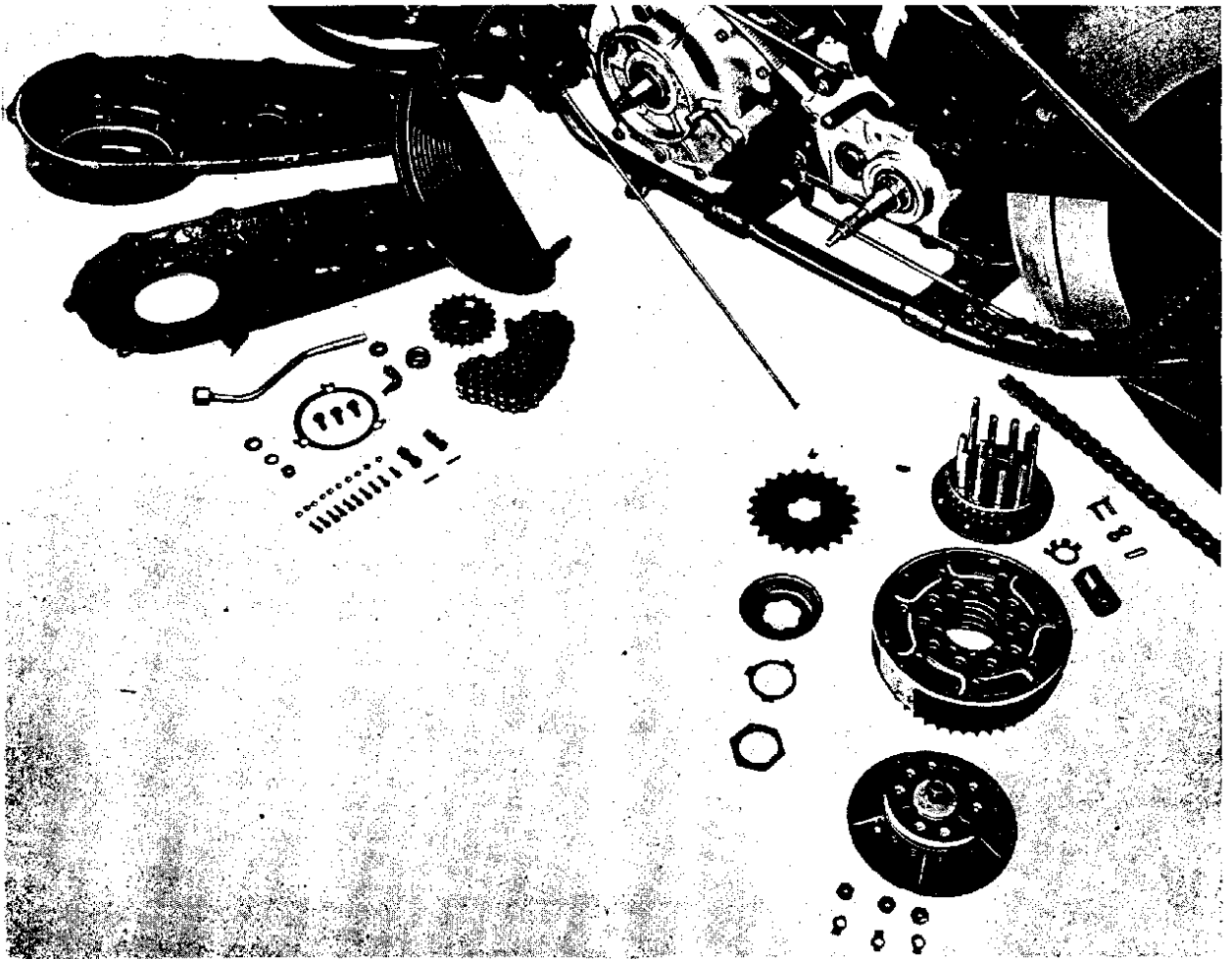

ILLUS. 117  
LEFT SIDE OF TRANSMISSION STRIPPED

### Removing Transmission From Chassis

1. Remove clutch control rod by loosening lock nut at pedal connection and turning rod out of connection.
2. Remove left footboard and studs only.
3. Remove outer front chain guard after removing screws and lock washers which secure it to inner chain guard.
4. Disconnect shifter rod from transmission lever after removing cotter pin and plain washer from end of rod.
5. Remove engine sprocket nut (right thread) using Harley-Davidson special wrench, Part No. 12645-26. It will be necessary to strike wrench handle with a hammer to loosen nut. Free sprocket from shaft taper by striking flat surface, near outer edge, a light but sharp rap with a hammer being careful not to strike sprocket teeth or sprocket shaft

threads. Sprocket and chain are then free to be removed.

6. Remove cotter pin, nut, flat washer and spring from each of the two inner chain guard rear mounting bolts. Bend ears of screw lock away from each of the three cap screws that secure front end of inner chain guard to crankcase, and remove cap screws and lock. Remove oil drain pipe from chain guard. *O.H.V. Models*—It will be necessary to remove oil spout and rubber seal from front chain oiler pipe.
7. Disconnect speedometer drive cable and housing from transmission.
8. Remove rear chain connecting link and chain.
9. Remove rear chain oiler pipe (if motorcycle is so equipped). First disconnect pipe from oil pump; then remove the clips which secure pipe to transmission and to sub-mounting plate.
10. Remove bolt which secures transmission to



support bracket on right side of frame.

11. Remove the two bolts and two cap screws which secure transmission sub-mounting plate to chassis.

12. Remove complete transmission (with sub-mounting plate, clutch and inner chain guard remaining attached) from left side of chassis (see Illus. 118).

Note: Clutch and inner chain guard can be removed before removing transmission, if desired (see Illus. 117).

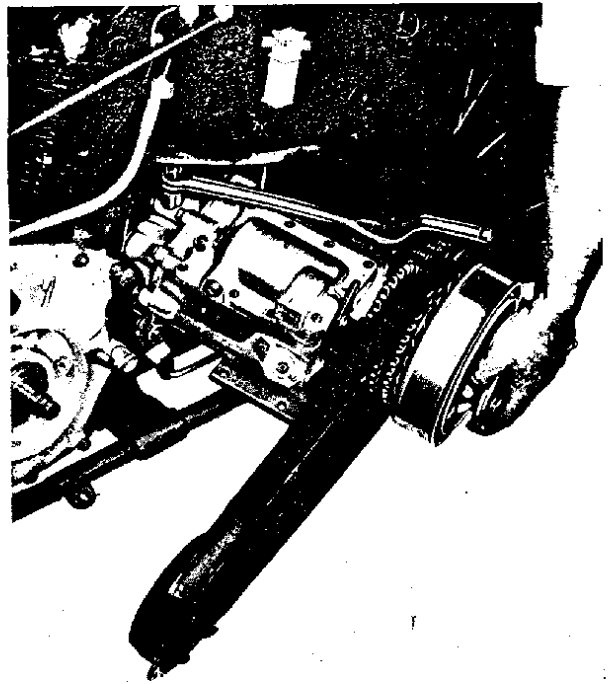

ILLUS. 118  
REMOVING TRANSMISSION FROM CHASSIS

IF SUB-MOUNTING PLATE IS FREED FROM CHASSIS, TRANSMISSION ASSEMBLY WITH SUB-MOUNTING PLATE ATTACHED, CAN BE REMOVED WITHOUT DISTURBING OIL TANK.

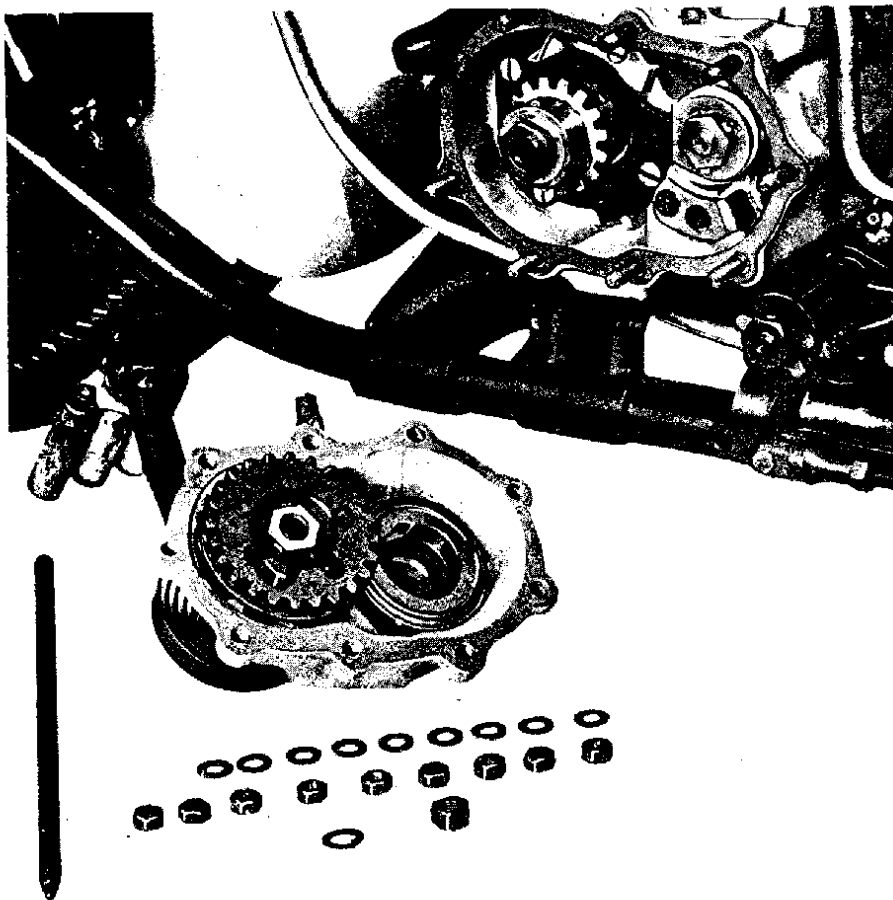

ILLUS. 119  
STARTER COVER  
ASSEMBLY REMOVED

STARTER COVER ASSEMBLY  
REMOVED PREPARATORY TO  
REMOVING STARTER MAIN-  
SHAFT PARTS AND/OR MAIN-  
SHAFT BALL BEARING

# STARTER COVER DISASSEMBLED

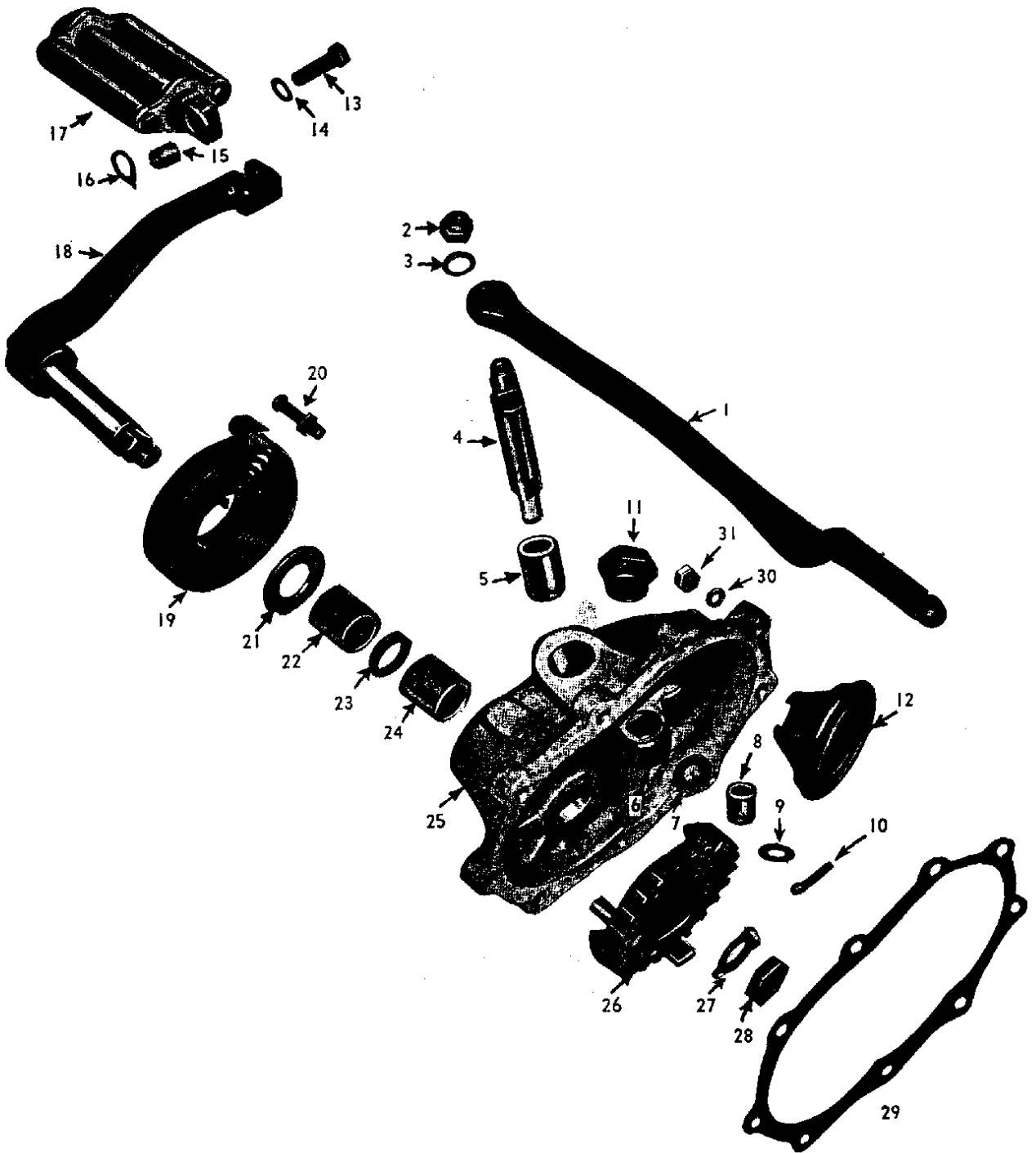

ILLUS. 120  
STARTER COVER DISASSEMBLED

X.

**STARTER COVER ASSEMBLY**

(Item Numbers Refer to Illus. 120)

ITEM	NUMBER USED—1940 TO 1947			PART NUMBER	NAME
	4 SPEED	3 SPEED REVERSE	3 SPEED		
* 1	1	1	1	2426-36	Clutch Release Lever
2	1	1	1	0133	Clutch Release Lever Shaft Nut
3	1	1	1	0265	Lock Washer
4	1	1	1	2430-38	Clutch Release Lever Shaft
5	1	1	1	2346-36	Clutch Release Lever Shaft Bushing (upper)
6	1	1	1	2436-39	Clutch Release Finger
7	1	1	1	2436-36A	Plain Washer (upper)
8	1	1	1	2345-38A	Clutch Release Lever Shaft Bushing (lower)
9	1	1	1	0214	Plain Washer (lower)
10	1	1	1	0291	Cotter Pin
11	1	1	1	2326-36	Oil Filler Plug
12	1	1	1	2448-39	Clutch Push Rod Bearing (complete)
13	1	1	1	2100-16	Pedal Pin Bolt
14	1	1	1	0261	Lock Washer
15	1	1	1	2101-31	Pedal Pin Bushing
16	1	1	1	2102-30	Pedal Pin Spring Washer
17	1	1	1	2091-16	Starter Pedal (complete)
18	1	1	1	2076-36	Starter Crank
19	1	1	1	2084-36	Starter Crank Spring
20	1	1	1	2086-36	Starter Spring Stud
21	1	1	1	2077-36	Starter Crank Plain Washer Inside Diameter— $\frac{3}{4}$ " Outside Diameter— $1\frac{1}{2}$ " Thickness— $\frac{1}{8}$ "
22	2	2	2	2127-37	Starter Crank Bushing (same as Item 24)
23	1	1	1	2078-37	Starter Crank Oil Seal
24	...	See Item 22	...	.....	.....
25	1	1	1	2126-36	Starter Cover
26	1	1	1	2144-36	Starter Crank Gear (24 teeth)
27	1	1	1	2080-16	Starter Crank Nut Lock Washer
28	1	1	1	2079-36	Starter Crank Nut
29	1	1	1	2132-36	Starter Cover Gasket
30	9	9	9	0214	Starter Cover Stud Washer
31	9	9	9	0117	Starter Cover Stud Nut

MAIN DRIVE GEAR GROUP DISASSEMBLED

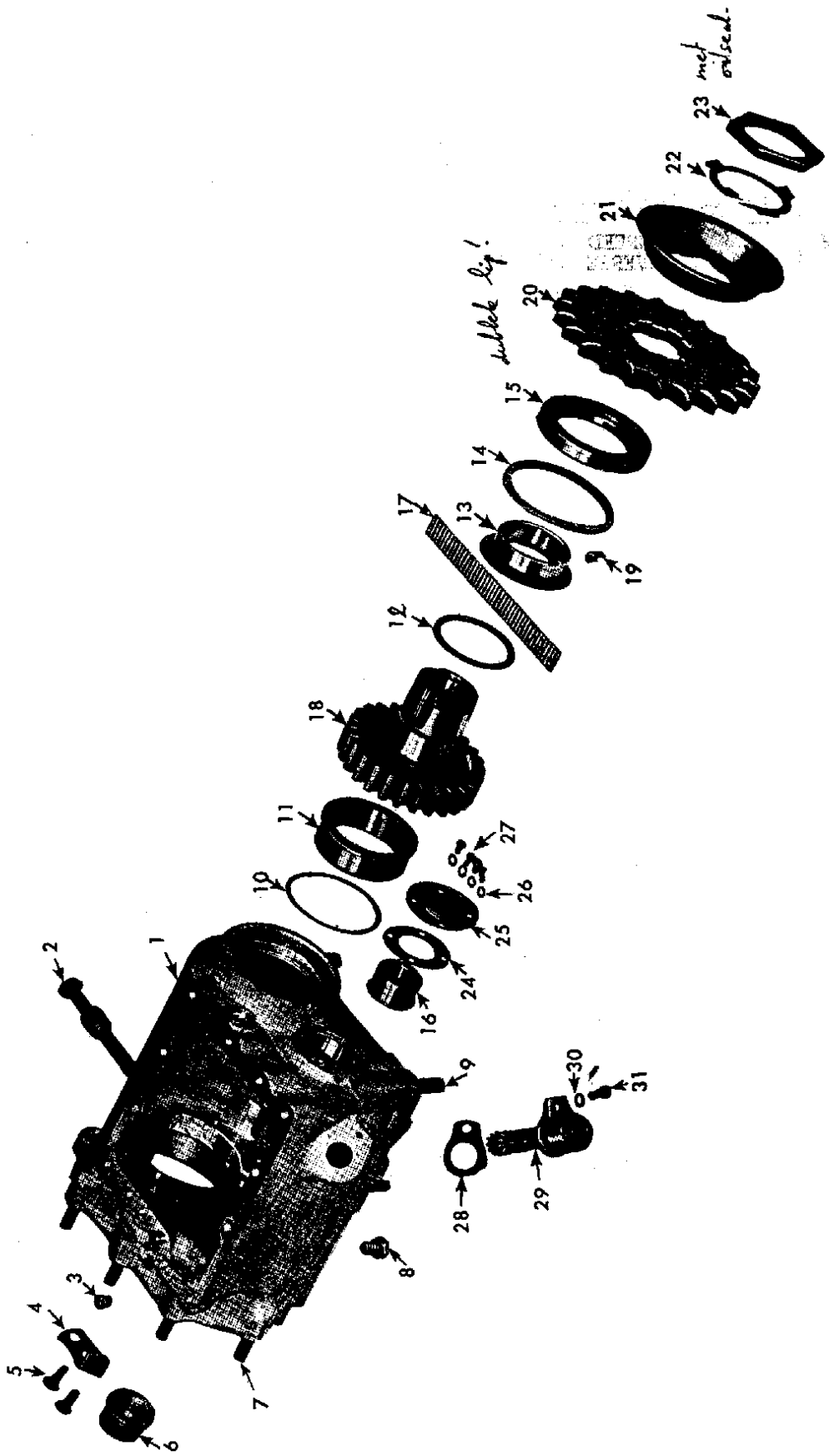

ILLUS. 121  
TRANSMISSION DISASSEMBLED—MAIN DRIVE GEAR GROUP

## TRANSMISSION ASSEMBLY — MAIN DRIVE GEAR GROUP

(Item Numbers Refer to Illus. 121)

ITEM	NUMBER USED—1940 TO 1947			PART NUMBER	NAME
	4 SPEED	3 SPEED REVERSE	3 SPEED		
*1	1	1	1	2258-36	Transmission Case—Items 2 to 16 inclusive are furnished with each parts order case shipped from factory—Items 6, 11, 15 and 16 are press fit in case
2	1	1	1	2328-36	Adjusting Screw (front chain) in transmission
3	1	1	1	2265-36	Vent Nipple
4	1	1	1	2145-36	Starter Gear Bumper Plate
5	2	2	2	3813-30	Starter Gear Bumper Plate Screw
6	1	1	1	2314-36	Countershaft Mounting Collar (right side)
7	9	9	9	2134-36	Starter Cover Mounting Stud
8	1	1	1	453-11	Transmission Drain Plug
9	4	4	4	2318-36	Transmission Mounting Stud—(oversize stud furnished under Part No. 2318-36S)
10	1	1	1	2284-36A	Outer Bearing Race Lock Ring
11	1	1	1	2284-37	Outer Bearing Race
12	1	1	1	2290-36	Main Drive Gear Thrust Washer Inside Diameter— $1\frac{21}{32}$ " Outside Diameter— $2\frac{3}{64}$ " Thickness—washer used in production .060"; washer furnished on parts order .050". See footnote
13	1	1	1	2339-37	Main Drive Gear Spacer
14	1	1	1	2163-36B	Oil Seal Cork Washer
15	1	1	1	2163-36	Oil Seal
16	1	1	1	2314-36A	Countershaft Mounting Collar (left side)
17	44	44	44	2289-36	Bearing Roller—Standard Size .125" x .615; available in .0004" to .0008" oversizes
18	1	1	1	2296-38	Main Drive Gear
19	1	1	1	2339-38	Main Drive Gear Spacer Key
20	1	1	1	2035-36	Countershaft Sprocket
21	1	1	1	2290-39	Main Drive Gear Oil Deflector
22	1	1	1	2337-36	Sprocket Lock Nut Washer
23	1	1	1	2335-36	Sprocket Lock Nut
24	1	1	1	2307-36D	Countershaft End Cap Gasket
25	1	1	1	2307-36E	Countershaft End Cap
26	4	4	4	0352	Countershaft End Cap Screw Lock Washer
27	4	4	4	016	Countershaft End Cap Screw
28	1	1	1	11140-36	Speedometer Drive Unit Gasket
29	1	1	1	11138-36	Speedometer Drive Unit
30	1	1	1	0254	Drive Unit Screw Lock Washer
31	1	1	1	032	Drive Unit Screw

FOOTNOTE: Parts order thrust washer (12) is .010" thinner than production thrust washer to make sure of providing sufficient endplay for any main drive gear assembly with which it may be used. Main drive gear assembly endplay should be .005" to .014".

1937 and early 1938 gear assemblies without copper gasket require the .050" washer to obtain sufficient endplay. All other gear assemblies originally fitted with .060" washer will have .010" additional endplay when fitted with .050" washer. However, this extra endplay is of no great importance as concerns operation. Washer very seldom needs renewing.

Caution Regarding Fitting of Oversize Rollers: Fitting oversize rollers to take up radial clearance also takes up circumferential clearance. Therefore, care must be taken to avoid crowding of rollers. Assemble specified number of rollers and observe whether last roller goes into place freely and without any effort to force it; if it doesn't go into place freely, leave it out.



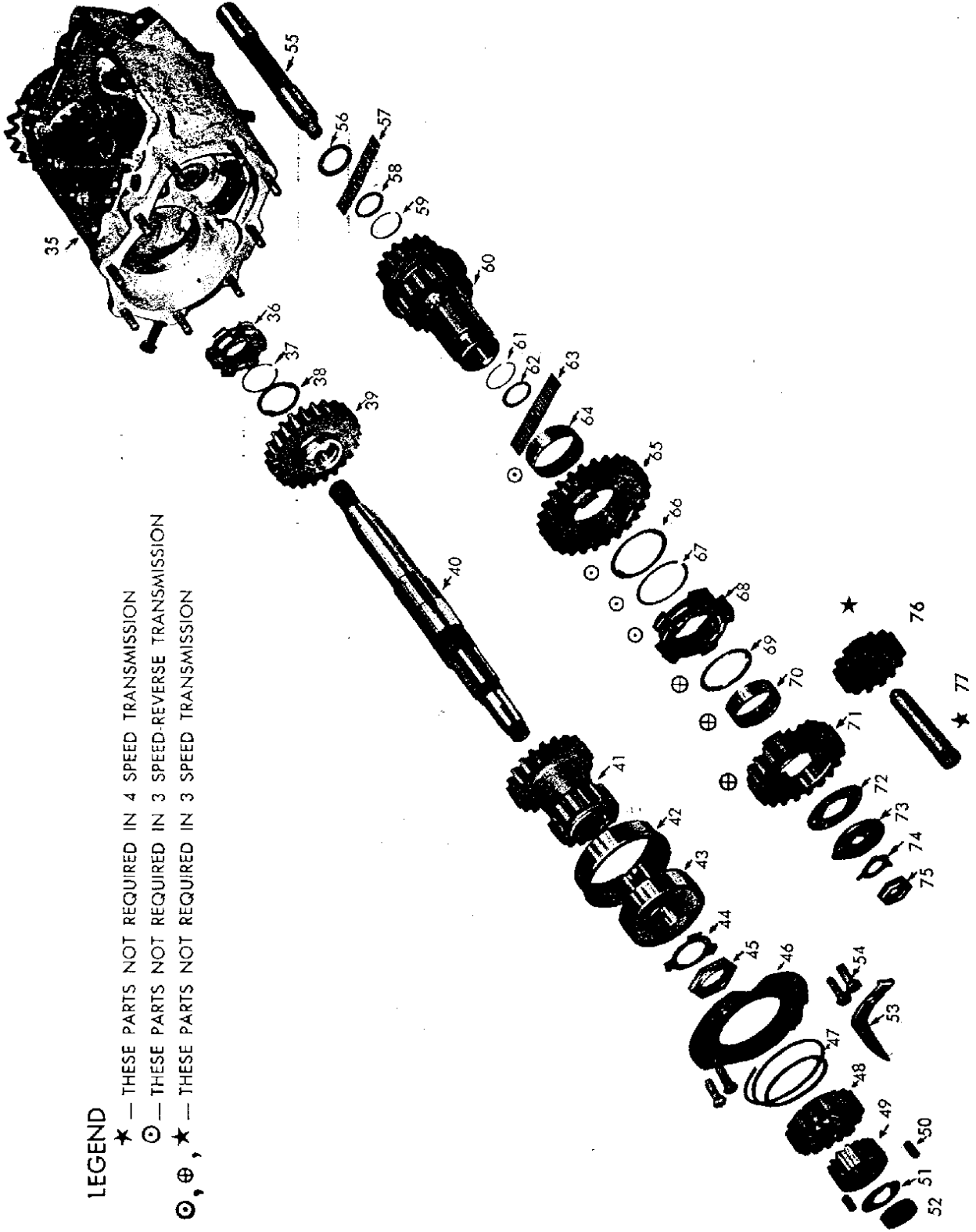

**LEGEND**

- ★ — THESE PARTS NOT REQUIRED IN 4 SPEED TRANSMISSION
- ⊙ — THESE PARTS NOT REQUIRED IN 3 SPEED-REVERSE TRANSMISSION
- ⊕, ★ — THESE PARTS NOT REQUIRED IN 3 SPEED TRANSMISSION

ILLUS. 122  
 TRANSMISSION DISASSEMBLED—MAINSHAFT AND COUNTERSHAFT GEAR GROUP

# TRANSMISSION ASSEMBLY — MAINSHAFT AND COUNTERSHAFT GROUP

(Item Numbers Refer to Illus. 122)

Note: Dash(—) indicates part not required.

ITEM	NUMBER USED—1940 TO 1947			PART NUMBER	NAME
	4 SPEED	3 SPEED REVERSE	3 SPEED		
35	1	1	1	.....	Transmission Case, with main drive gear and countershaft sprocket assembled in case — no part number furnished for transmission case in this stage of assembly.
36	1	1	1	2298-38A	Mainshaft Shifter Clutch
37	1	1	1	2297-36B	Thrust Washer Lock Ring
38	1	1	1	2297-36A	Mainshaft Gear Thrust Washer Inside Diameter—1.164" Outside Diameter—1 1/2" Thickness—.062"
39	1	1	1	2296-36B	Mainshaft Third Gear (24 teeth)
40	1	1	1	2295-38	Mainshaft Second Gear (22 teeth)
41	1	1	1	2272-36	Mainshaft
42	1	1	1	2297-36	Mainshaft Low and Second Gear (15 and 20 teeth)
43	1	1	1	2296-39	Mainshaft Low and Reverse Gear (15 and 16 teeth)
44	1	1	1	2161-36	Mainshaft Ball Bearing Housing
45	1	1	1	2280-36	Mainshaft Ball Bearing
46	1	1	1	2281-40A	Mainshaft Ball Bearing Nut Lock Washer
47	1	1	1	2281-36A	Mainshaft Ball Bearing Lock Nut
48	1	1	1	2162-36A	Bearing Housing Retaining Plate
49	1	1	1	2152-36	Starter Clutch Spring
50	2	2	2	2155-36	Starter Mainshaft Gear (16 teeth)
51	1	1	1	2146-39	Starter Clutch
52	1	1	1	2147-16	Starter Clutch Key
53	1	1	1	2149-39	Starter Clutch Nut Lock Washer
54	4	4	4	2274-36	Starter Clutch Lock Nut
55	1	1	1	2151-39	Starter Gear Oil Deflector
56	1	1	1	2268-36	Bearing Housing Retaining Plate Screw
57	44	44	44	2300-36	Countershaft
58	2	2	2	2308-36A	Countershaft Gear Roller Retaining Washer Inside Diameter—7/16" Outside Diameter—1 1/4" Thickness—.056"
59	2	2	2	2289-36	Bearing Roller—Standard Size .125" x .615"; available in .0004" and .0008" oversizes (same as Item 63)
60	1	1	1	2307-36	Bearing Roller Retaining Washer (same as Item 62) Inside Diameter—.788" Outside Diameter—1.003" Thickness—.060"
61	...	See Item 59	...	2307-36A	Retaining Washer Lock Ring—(same as Item 61)
62	...	See Item 58	...	2303-36	Countershaft Gear (15 and 17 teeth)
63	...	See Item 57	...	2303-39	Countershaft Gear (15 and 19 teeth)
64	1	—	—	2304-36D	Second Gear Bushing
65	1	1	1	2301-36	Countershaft Second Gear (21 teeth)
66	1	—	—	2302-39	Countershaft Low Gear (Sliding Gear) (25 teeth)
67	1	—	—	2302-36A	Second Gear Thrust Washer Inside Diameter—1.566" Outside Diameter—1 7/8" Thickness—.053"
68	1	—	—	2302-36B	Thrust Washer Lock Ring
69	1	1	—	2298-36B	Countershaft Shifter Clutch
70	1	1	—	2304-36E	Low or Reverse Gear Bearing Washer Inside Diameter—1 1/4" Outside Diameter—1 11/16" Thickness—.058"
71	1	1	—	2297-36E	Low or Reverse Gear Bushing
72	1	1	1	2304-36	Countershaft Low Gear (26 teeth)
73	1	1	1	2304-39A	Countershaft Reverse Gear (23 teeth)
74	1	1	1	2308-36	Countershaft Gear Endplay Adjusting Spacer Inside Diameter—.757" Outside Diameter—1 1/4" Thickness—Available in four thicknesses: .074", .078", .082", and .085"
75	1	1	1	2300-36A	Countershaft Lock Plate
76	—	1	—	2080-16	Countershaft Nut Lock Washer
77	—	1	—	2079-36	Countershaft Lock Nut
	—	1	—	2365-36	Reverse Idler Gear (14 teeth)
	—	1	—	2367-36	Reverse Idler Gear Shaft

Caution Regarding Fitting of Oversize Rollers: Fitting oversize rollers to take up radial clearance also takes up circumferential clearance. Therefore, care must be taken to avoid crowding of rollers. Assemble specified number of rollers and observe whether last roller goes into place freely and without any effort to force it; if it doesn't go into place freely, leave it out.

SHIFTER FORK AND SHIFTER CAM GROUP DISASSEMBLED

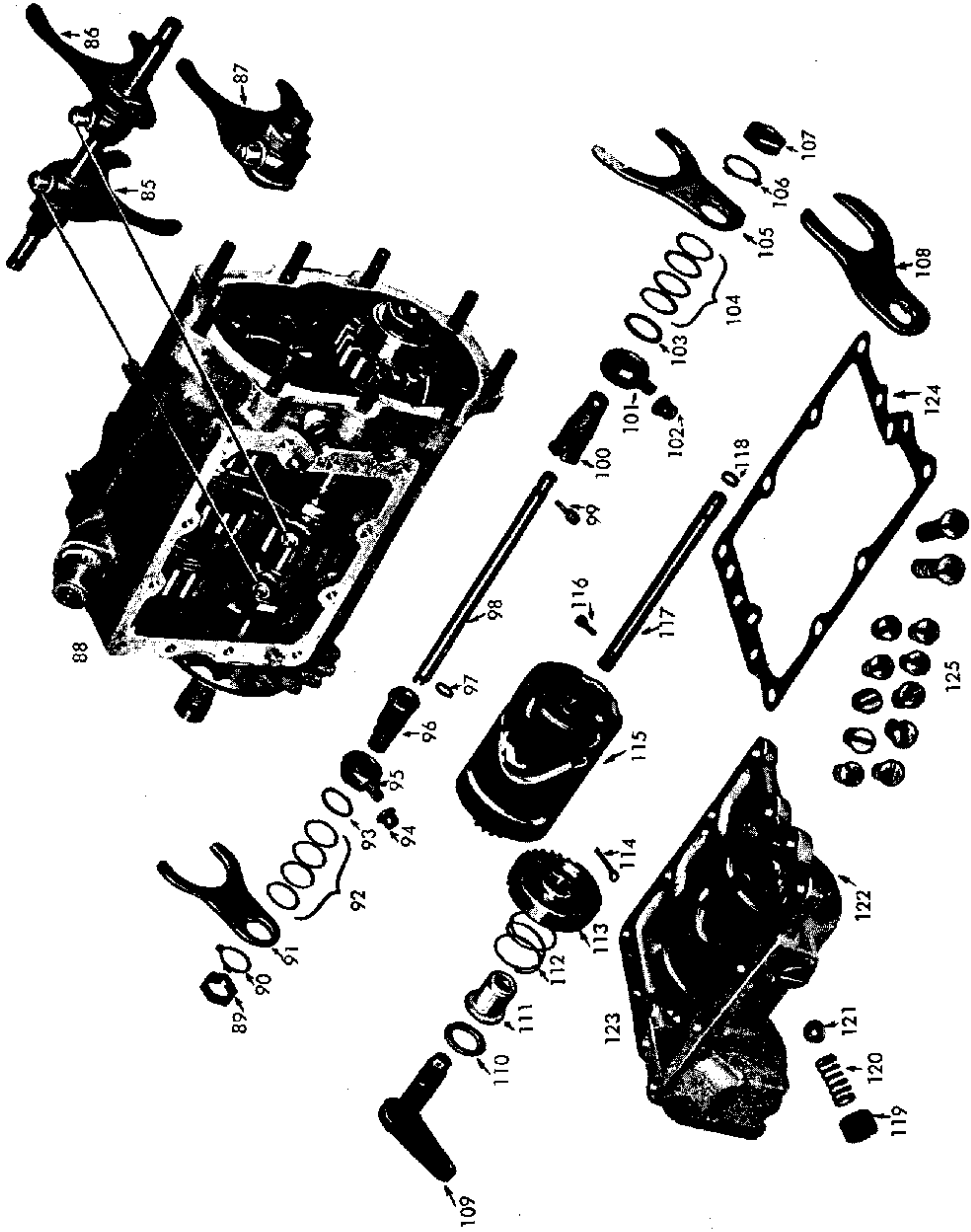

ILLUS. 123  
TRANSMISSION COVER AND SHIFTER FORKS DISASSEMBLED

# TRANSMISSION ASSEMBLY — SHIFTER FORK AND SHIFTER CAM GROUP

(Item Numbers Refer to Illus. 123)

ITEM	NUMBER USED—1940 TO 1947			PART NUMBER	NAME
	4 SPEED	3 SPEED REVERSE	3 SPEED		
85	1	1	1	.....	Shifter Fork Assembly (for mainshaft shifter clutch) consists of Items 89 to 96. No part number furnished for assembly.
86	1	...	...	.....	Shifter Fork Assembly (for countershaft shifter clutch)—consists of Items 100 to 107. No part number furnished for assembly. See footnote.
87	...	1	1	.....	Shifter Fork Assembly (for countershaft gear sliding gear)—consists of Items 100 to 108, except shifter fork, Item 105. No part number furnished for assembly. See footnote.
88	...	...	...	.....	Transmission Case with gears, shifter forks and shifter clutches assembled in a 4-speed transmission (not furnished by factory in this stage of assembly).
89	2	2	2	2250-33	Shifter Fork Bushing Nut (same as Item 107)
90	2	2	2	2251-33	Shifter Fork Bushing Nut Lock Washer (same as Item 106)
91	1	1	1	2246-36	Shifter Fork (for mainshaft shifter clutch)
92	Varies	Varies	Varies	{ 2253-33A 2253-33B	Spacing Shim—.014" } (same as Item 104) Spacing Shim—.007" }
93	2	2	2	2253-33	Inside Diameter— $\frac{1}{4}$ " Outside Diameter— $\frac{5}{16}$ " Spacing Shim— $\frac{5}{64}$ " thick (same as Item 103) Inside Diameter— $\frac{1}{4}$ " Outside Diameter— $\frac{5}{16}$ "
94	2	2	2	2248-39	Shifter Finger Roller (same as Item 102)
95	2	2	2	2248-36	Shifter Finger (same as Item 101)
96	2	2	2	2249-36	Shifter Fork Bushing (same as Item 100)
97	2	2	2	2245-36A	Shifter Fork Shaft and Shifter Cam Shaft Oil Seal Washer (same as Item 118)
98	1	1	1	2245-36	Shifter Fork Shaft
99	1	1	1	2244-36A	Shifter Fork Shaft Lock Screw
100	...	See Item 96	...	.....	.....
101	...	See Item 95	...	.....	.....
102	...	See Item 94	...	.....	.....
103	...	See Item 93	...	.....	.....
104	...	See Item 92	...	.....	.....
105	1	...	...	2247-36	Shifter Fork (for countershaft shifter clutch)
106	...	See Item 90	...	.....	.....
107	...	See Item 89	...	.....	.....
108	...	1	1	2247-39	Shifter Fork (for countershaft sliding gear)
109	1	1	1	2242-36	Gear Shifter Lever and Shaft
110	1	1	1	2245-26	Shifter Shaft Leather Washer
111	1	1	1	2242-36C	Shifter Shaft Bushing
112	1	1	1	2166-26	Shifter Shaft and Gear Thrust Spring
113	1	1	1	2242-36A	Shifter Gear
114	1	1	1	0291	Cotter Pin
115	1	1	1	2243-36	Shifter Cam
116	1	1	1	2243-39	Shifter Cam
117	1	1	1	2244-36A	Shifter Cam Shaft Lock Screw
118	...	See Item 97	...	2245-36	Shifter Cam Shaft
119	1	1	1	2251-36B	Shifter Cam Plunger Adjusting Screw
120	1	1	1	2251-36A	Shifter Cam Plunger Ball Spring
121	1	1	1	2251-36	Shifter Cam Plunger Ball
122	1	1	1	2259-36	Transmission Cover Only
123	1	1	1	2259-36A	Transmission Cover and Shifter Cam Assembly—consists of Items 109 to 122
124	1	1	1	2261-36	Transmission Cover and Shifter Cam Assembly—consists of Items 109 to 122
125	2	2	2	1523-32	Transmission Cover Gasket
	10	10	10	2268-36	Transmission Cover Screw (long) Transmission Cover Screw (short)

FOOTNOTE. Illustration shows correct assembly of items 100 to 107 that make up shifter fork assembly (86).

Items 100 to 108, except shifter fork (105) make up shifter fork assembly (87), however, the sequence of assembly of these items differs from that shown in illustration for shifter fork assembly (86). Assemble on shifter fork bushing (100) in following order—shifter fork (108), with offset as shown in illustration; spacing washers (103) and (104); shifter finger (101); lock washer (106); lock nut (107) and shifter finger roller (102).

## DISASSEMBLING TRANSMISSION

### Removing Clutch

If clutch has not already been removed, remove it. See "Disassembling Clutch, 1940 and earlier Models," Page 16, or "Disassembling Clutch, 1941 to 1947 Models," Page 17.

### Removing Speedometer Drive Unit

(To Identify Items, Refer to Illus. 121)

1. After removing screw (31), drive unit (29) is free to be pulled out of transmission case.

Be careful not to damage drive unit gasket unless a new replacement gasket is available.

### Removing Transmission Cover Assembly

(To Identify Items, Refer to Illus. 123)

2. Cover is secured by twelve screws (125) and is registered on two dowel pins. Note that two of the twelve cover screws are extra long. Avoid damaging cover gasket (124) unless a new replacement gasket is available.

Lock mainshaft and main drive gear to prevent them from turning while completing operations. This can be done by moving shifter forks (85) and (86), so transmission is engaged in two gear positions at same time.

### Removing Clutch Hub

(To Identify Items, Refer to Illus. 8 or 9)

3. Clutch hub is taper fit on transmission mainshaft and is secured by nut (9) or nut (12), depending on model—nut is left thread. Use Harley-Davidson special wrench, Part No. 12746-36 for nut (9), or special wrench, Part No. 12745-41 for nut (12).

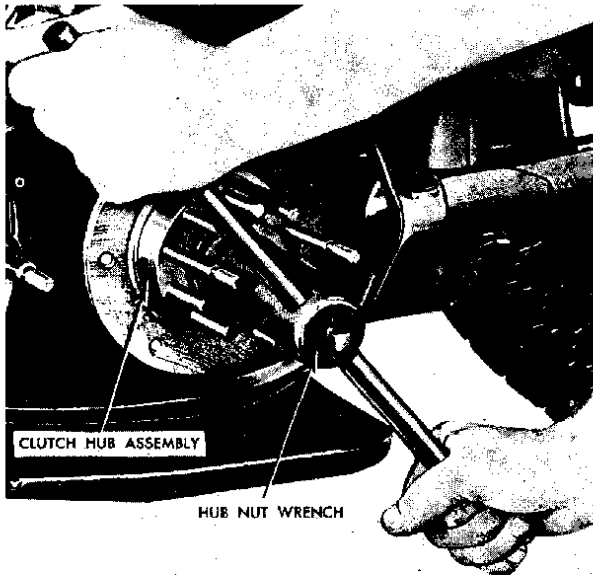

ILLUS. 124

REMOVING CLUTCH HUB NUT—1941 TO 1947 MODELS

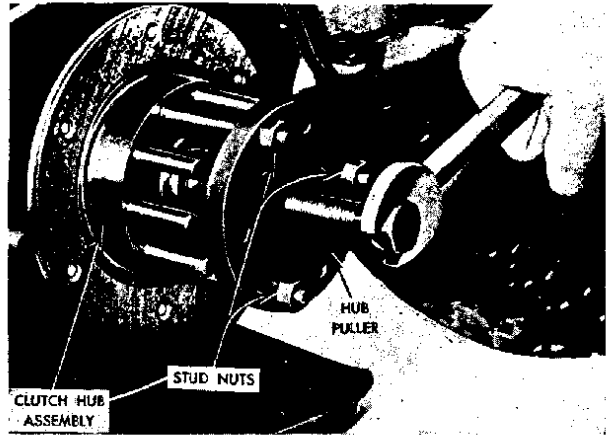

ILLUS. 125

REMOVING CLUTCH HUB—1941 TO 1947 MODELS

After removing nut and lock washer, use Harley-Davidson special puller to pull hub from mainshaft taper—puller Part No. 12749-36 for 1940 and earlier Models or Part No. 12022-41 for 1941 to 1947 Models. See Illus. 124 and 125 for removing 1941 to 1947 Model hub.

### Removing Sprocket

(To Identify Items, Refer to Illus. 121)

4. Bend ear of lock washer (22) away from side of sprocket lock nut (23). Remove nut (left thread) using Harley-Davidson special wrench, Part No. 12023-X. With nut and lock washer removed, oil deflector (21) and sprocket (20) are free to be removed from main drive gear spline. Note: Be careful not to lose main drive gear spacer key (19).

### Removing Starter Cover Assembly

(To Identify Items, Refer to Illus. 120)

5. Place oil drain pan under transmission. Remove starter cover nuts (31) and plain washers (30). Cover assembly with clutch release lever assembly is then free to be pulled off mounting studs. Clutch release bearing (12) will come off with cover—see Illus. 119. If starter cover binds, it is due to release bearing (12) binding on starter clutch. Pry bearing off starter clutch. Do not pry cover (25) as this will damage bearing. Avoid damaging cover gasket (29) unless a new replacement gasket is available.

With starter cover removed push rod is free to be pulled out of mainshaft.

### Removing Starter Clutch and Mainshaft Gear

(To Identify Items, Refer to Illus. 122)

6. Bend ear of lock washer (51) away from side of nut (52) and remove nut. Pull starter clutch (49) from mainshaft taper with Harley-Davidson special puller, Part No. 12737-43. See Illus. 126. With starter clutch removed, starter clutch keys (50), starter mainshaft gear (48) and starter clutch spring (47) are free to be removed from mainshaft.



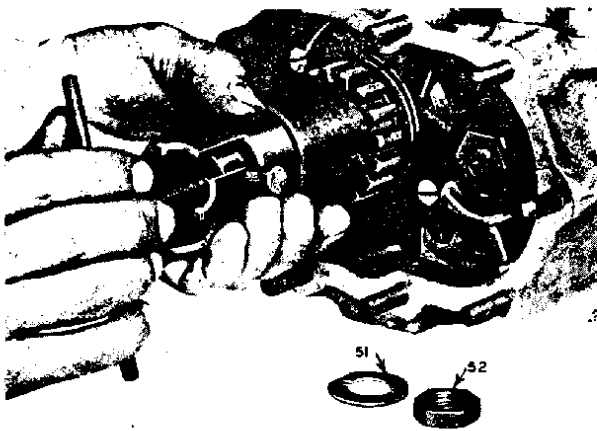

ILLUS. 126  
REMOVING STARTER CLUTCH

Note: Instructions for removing starter clutch are included with Harley-Davidson starter clutch and mainshaft ball bearing puller. Part No. 12737-43.

### Removing Shifter Fork and Shaft Assembly

(To Identify Items, Refer to Illus. 123)

7. Shifter fork shaft (98), is held in position by a set screw (99), head of which will be found in top cover joint face of transmission case (at right end of shaft). With set screw removed, shaft can be driven out by means of a drift inserted in hole provided for that purpose in starter cover joint face of transmission case. Note rubber oil seal (97) assembled in groove on left end of shaft. CAUTION: Bear in mind that shifter fork assemblies (85, 86 or 87) are not interchangeable; note exact arrangement of parts before disassembling. This precaution will save needless gauging and adjusting when reassembling. If inspection shows fork assemblies are not damaged or worn it will not be necessary to disassemble them.

### Removing Countershaft Gear Assembly

(To Identify Items, Refer to Illus. 121 and 122)

8. Remove countershaft end cap (25) and gasket (24), from left side of transmission case. Avoid damaging end cap gasket unless a new replacement gasket is available. Bend ear of lock washer (74) away from side of countershaft nut (75) and remove nut, lock washer and countershaft lock plate (73). Countershaft (55) can be driven out of case toward left (clutch) side. Countershaft gear assembly can now be withdrawn from transmission case.

Do not misplace end play adjusting washer (72) and roller bearing thrust washer (56). CAUTION: Countershaft gear runs on two sets roller bearings (57) and (63) one on each end of countershaft. Each set consists of 22 rollers. In removing countershaft gear assembly, be sure all rollers are accounted for

and that rollers from each end of gear are wrapped in paper or rag, and marked for end of gear from which they were removed. If any of the rollers are lost, or if rollers from one set become mixed with the other, entire set will have to be discarded and a complete new set fitted, even though old rollers are in good condition.

### Removing Mainshaft Assembly and Main Drive Gear Assembly

(To Identify Items, Refer to Illus. 121 and 122)

9. Remove the four bearing housing retaining plate screws (54) and retaining plate (46). Note that starter gear oil deflector (53) is held in place by the upper front screw, and that V-notch in retaining plate is upward and toward the front—see Illus. 119.

If a 3 speed-reverse transmission, remove idler gear (76) and shaft (77) before proceeding with removal of mainshaft. With retaining plate removed, pull idler gear shaft (77) out of case by threading a 1/4" 20 cap screw into end of shaft and grasping screw with pliers.

Drive mainshaft assembly from right side of transmission case with rawhide mallet (or block of wood and hammer) until mainshaft bearing (43) or bearing housing (42) together with bearing, are just free from case. With suitable tool pry lock ring (37) out of groove in mainshaft and slide it onto mainshaft splines. If bearing housing does not come out with bearing, place larger of the two gears (41) against housing, and drive housing out together with mainshaft. To avoid possible damage to transmission case make sure gear is positioned so it does not overlap housing when shaft and housing are being driven out.

After mainshaft is free from main drive gear, shifter clutch (36), lock ring (37), thrust washer (38) and gear (39) can be slipped off mainshaft.

Push main drive gear (18) into case and withdraw it from top. Thrust washer (12), usually comes out with main drive gear. CAUTION: Main drive gear runs in roller bearing (17) consisting of 44 rollers. When removing main drive gear, be sure all rollers are accounted for and wrap them in paper or rag. If any of these rollers are lost, or if rollers from another bearing become mixed with them, the entire set must be discarded and a new set fitted, even though old rollers are in good condition.

Do not remove main drive gear oil seal (15) or main drive gear spacer (13) unless inspection shows them damaged or worn. To renew main drive gear oil seal or main drive gear spacer, see "Renewing Main Drive Gear Oil Seal," Page 144.

10. Miscellaneous transmission case fittings, such as studs, chain adjusting screw, dowel pins, vent nipple and starter crank return spring stud need not be removed unless they require replacement.

Note: The following disassembly operations (11 to 17 inclusive) need not be done, except where inspection shows need for replacing worn or damaged parts.

## Removing Mainshaft Gear and Ball Bearing From Mainshaft

(To Identify Items, Refer to Illus. 122)

11. Clamp mainshaft in copper-faced vise jaws. Bend ear of lock washer (44) away from side of bearing lock nut (45) and remove nut and washer.

Bearing and gear can be removed with Harley-Davidson all purpose puller, Part No. 12738-46 or an arbor press.

If using all purpose puller, insert center adapter (furnished with Harley-Davidson starter clutch and mainshaft ball bearing puller, Part No. 12737-43) in end of shaft to prevent possibility of damaging shaft. Bearing and gear must be removed separately.

If using an arbor press, place the assembly, bearing end upward in press, supported on larger end of mainshaft gear. Insert adapter or  $\frac{3}{8}$ " bolt in end of shaft to push against and push shaft out of bearing (43) and gear (41) by applying pressure to upper end of shaft.

## Removing Shifter Cam and Lever Assembly

(To Identify Items, Refer to Illus. 123)

12. Remove shaft set screw (116). Shaft (117) can then be driven out, using a discarded valve as a drift. Set edge of valve head in groove at end of shaft and drive on end of valve stem with a light hammer. Note oil seal (118) assembled in groove at right end of shaft. With shaft removed, shifter cam is free to come out of cover.

Pull cotter pin from shifter lever shaft (109). Shifter lever shaft can then be pulled out of cover, thus freeing gear (113) and spring (112).

Remove plunger adjusting screw (119) and spring (120). Ball (121) is then free to drop out of cover.

## Removing Starter Crank

(To Identify Items, Refer to Illus. 120)

13. Clamp crank (18) in vise, bend ear of lock washer (27) away from side of starter crank nut (28) and remove nut and lock washer. Remove starter gear (26) using Harley-Davidson all purpose puller, Part No. 12738-46. If puller is not available, remove starter assembly from vise. Drive starter crank out of starter gear (26) with a rawhide mallet (or hammer and block of wood).

Be sure to hold starter crank and cover in such a manner that starter crank or cover does not swing around when gear or crank is removed.

With starter gear removed, crank can be pulled out of cover. Note: Thrust washer (21) is installed between starter crank spring (19) and cover (25) with chamfered side of washer facing spring.

## Removing Clutch Release Lever

(To Identify Items, Refer to Illus. 120)

14. To remove nut and lock washer which secure release lever (1) to squared end of release lever

shaft (4). Release lever can then be pulled off of squared end of shaft, using Harley-Davidson all purpose puller, Part No. 12738-46.

Remove cotter pin (10) and plain washer (9) from lower end of release lever shaft. Release lever shaft can then be pulled out of cover (25), thus freeing release finger (6) and thrust washer (7).

## Removing Countershaft Mounting Collars and Starter Crank Bushings

(To Identify Items, Refer to Illus. 120 and 121)

15. The two steel countershaft mounting collars (6) and (16), in transmission case, and the two bronze starter crank bushings, (22) and (24), in starter cover can be removed by pressing them out with arbor press or driving them out with suitable drift. An oil seal (23) is located between the two starter crank bushings.

## Removing Main Drive Gear Outer Bearing Race

(To Identify Items, Refer to Illus. 121)

16. Should outer bearing race (11) need replacing, main drive gear oil seal (15) must be removed first. Use a suitable drift and hammer. Drive the sprocket spacer (13) together with oil seal from left side of transmission case. CAUTION: While driving, precaution must be taken not to allow seal to tip. If seal tips, damage may result to transmission case. Remove bearing race lock ring (10). Heat section of transmission case (not to exceed 300°) around bearing race and it can then be removed easily by pressing out with arbor press or driving out with hammer and block of wood.

## Removing Shifter Shaft Bushing

(To Identify Items, Refer to Illus. 123)

17. Thread a 5/8" tap into bushing (111) approximately 1/2". Remove tap temporarily and heat section of cover (not to exceed 300°) around bushing. Replace tap, and with shank of tap held horizontally and securely in vise jaws, tap cover (122) with rawhide mallet or block of wood and hammer. Heat will cause aluminum to expand around bushing, making it comparatively easy to remove.

## Inspection of Parts

(To Identify Items, Refer to Illus. 122)

Clean all parts thoroughly and inspect to determine which must be renewed. Check all gears. If teeth are pitted, scored, cracked, chipped or if case hardening is worn through, replace with new gears. If 3 speed or 3 speed-reverse transmission, note particularly the condition of sliding gear (65).

Also inspect all bushings, bearing races and shafts, if bent or worn, renew. If mainshaft ball bearing (43), is worn to the extent that it has appreciable play or shake, renew it.

Give especially close attention to possibly bat-

tered or rounded condition of shifter clutch engaging dogs and gear engaging dogs or slots.

This condition results from shifting abuses or possibly from poorly adjusted clutch that does not release fully.

Damaged engaging dogs and slots try to creep out of engagement under steady driving load. This creeping action develops tremendous side pressure that finally results in damage in shifting mechanism and all thrust points along shaft assemblies. Therefore, in doing a thorough and dependable transmission overhaul, it is of prime importance that all gears and shifter clutches with badly rounded engaging dogs and slots be replaced with new ones.

## ASSEMBLING TRANSMISSION

### Installing Main Drive Gear Assembly

(To Identify Items, Refer to Illus. 121)

1. To install outer bearing race (11), first, heat case to not over 300°F. Heating will expand metal slightly and bearing race can be pressed in with less force. Be careful to install race squarely in bore, and make sure race flange is snug against case. Install bearing race retaining ring (10) and make sure it is properly seated in its groove.

Oil seal cork washer (14) and oil seal (15) should not be reinstalled once they have been removed from transmission case. They are very likely to be damaged during removing operation, and if so, oil leakage probably will result. Main drive gear spacer (13) must be installed before installing oil seal cork washer (14) and oil seal (15). See "Renewing Main Drive Gear Oil Seal," Page 144.

Assuming that main drive gear oil seal (15), oil seal cork washer (14) and main drive gear spacer (13) are already assembled in case, install rollers (17) in bearing outer race (11) holding rollers in place with a light coat of heavy grease.

Install main drive gear thrust washer (12) on main drive gear. See Item (12) under "Transmission Assembly—Main Drive Gear Group," Page 131.

Insert main drive gear. Be sure rollers stay in place as gear is entered. Roller bearing clearance should be .0006" to .001" loose.

Install main drive gear spacer key (19) registering longer section of key in a splineway on main drive gear and shorter section of key in slot in outer end of main drive gear spacer (13).

Install sprocket (20) with flat side outward. Install oil deflector (21), sprocket nut lock washer (22) and sprocket lock nut (23). Hold sprocket and tighten nut securely and check main drive gear for endplay. Assembly should have from .005" to .014" end play. (See footnote under "Transmission Assembly—Main Drive Gear Group," Page 131). Bend one ear of lock washer against one side of lock nut.

### Installing Mainshaft Assembly

(To Identify Items, Refer to Illus. 122)

2. Assemble following parts onto mainshaft before installing shaft—gear (41), ball bearing hous-

ing (42), and mainshaft ball bearing (43) assembled, bearing lock washer (44) and lock nut (45), with flat surface of nut inward facing lock washer. Tighten nut securely and bend over one ear of lock washer against one side of nut.

Enter mainshaft into transmission case far enough to install gear (39), thrust washer (38), gear lock ring (37), and mainshaft shifter clutch (36) onto mainshaft. Always install a new gear lock ring and make sure it is properly seated in its groove. Beveled side of mainshaft shifter clutch is stamped "HIGH". Make sure this side faces main-drive gear.

Using a soft hammer or brass drift, tap mainshaft assembly in as far as ball bearing housing will permit. Install retaining plate (46) and oil deflector (53) as shown in Illus. 119. Oil deflector is held by upper, front retaining plate screw. Tighten screws securely.

Note: If 3 speed-reverse transmission, install reverse idler gear (76) and idler gear shaft (77) after installing mainshaft assembly.

### Adjusting Countershaft Gear Endplay

(To Identify Items, Refer to Illus. 121 and 122)

3. If countershaft mounting collars (6) and (16) were removed for renewal, press or drive them in from inside of transmission case, making sure collar flanges are snug against case. If case is heated, (not over 300° F.) less force will be required when pressing or driving in collars.

Install rollers (57) and (63) in countershaft gear (60), holding them in place by means of a light coat of heavy grease. Be sure lock rings (59) and (61) and bearing retaining washers (58) and (62) are in place before installing rollers. Install bearing thrust washer (56) in its recess in left end of countershaft gear. Install countershaft temporarily to check bearing fit—should be .0006" to .001" loose.

Install countershaft gear in case holding endplay adjusting washer (72) (right side) in place with heavy grease. Install countershaft (55).

Check endplay with feeler gauge, between endplay adjusting washer and end of countershaft gear. Endplay should be .008" or .012". Increase or decrease endplay as necessary by fitting endplay adjusting washer of required thickness. Washers available in thicknesses of .074", .078", .082", and .085".

After correct countershaft gear endplay has been established, remove countershaft and countershaft gear from case. Set aside adjusting washer selected, to be sure it goes into final assembly.

### Installing Countershaft Gear Assembly, Starter Clutch, Sprocket and Speedometer Drive Unit

(To Identify Items, Refer to Illus. 121 and 122)

4. 4-Speed Transmission—Install gear bushing (64), gear (65), thrust washer (66), gear lock ring (67) on countershaft gear. Next install shifter clutch (68), thrust washer (69), gear bushing (70) and gear (71) on countershaft gear. Always install a new gear

lock ring and make sure it is properly seated in its groove. Items identified with ★ not required in 4 speed transmission.

**3 Speed-Reverse Transmission**—Install gear (65), thrust washer (69), gear bushing (70) and gear (71). Items identified with ⊙ not required in 3 speed-reverse transmission.

**3-Speed Transmission**—Install gear (65). Items identified with ⊙, ⊕, ★, not required in 3 speed transmission.

Recheck to make sure all rollers and washers are in place in countershaft gear.

Place endplay adjusting washer (72) on end of countershaft gear, holding it in position with heavy grease. Install countershaft gear assembly and end-play adjusting washer, and install countershaft (55) and lock plate (73). Straight edge of lock plate fits against edge of bearing retaining plate (46). Line up shaft so it can be entered in hole in lock plate. Install lock washer (74) and nut (75). Tighten nut securely and bend over one ear of lock washer against one side of nut. Install gasket (24) and countershaft end cap (25) over left end of countershaft (turned-up edge of cap to outside). Install lock washers (26) and screws (27) and tighten screws securely.

Install starter clutch spring (47) (large end inward), starter mainshaft gear (48), starter clutch keys (50), starter clutch (49), starter clutch nut lock washer (51) and starter clutch nut (52).

By means of shifter clutches, or shifter clutch and sliding gear, engage transmission in two gear positions at the same time, to lock transmission and then securely tighten starter clutch lock nut. Bend edge of lock washer (51) against one side of starter clutch lock nut.

Install speedometer drive assembly (29). Make sure gasket (28) is in place and gears mesh properly. Unit should slide in freely. Install screw (31) and lock washer (30).

### Installing Shifter Forks

(To Identify Items, Refer to Illus. 123)

5. If shifter fork assemblies (85) and (86), or (87), have been disassembled, reassemble in correct order as shown in illustration. Place shifter forks in transmission (fork with narrower opening is for high gear shifter clutch) and install shifter fork shaft (96). Be sure shifter fork bushings are free on shaft. If binding slightly, free by lapping with fine compound. If binding considerably, replace with new bushings. Shifting will be difficult unless bushings work freely on shaft. Be sure rubber oil seal (97) is in groove on left end of shaft. Note that threaded ends of shifter fork bushings (96) and (100) both point outward (away from each other).

### Installing Shifter Lever and Shaft and Shifter Cam

(To Identify Items, Refer to Illus. 123)

6. If shifter lever and shaft (109) and/or shifter cam (115) have been removed from cover (122) it

is necessary to time shifter lever gear (113) with gear on shifter cam (115).

To install shifter lever shaft bushing (111), press or drive it into top cover, making sure bushing flange is seated snug against cover.

**1946 and earlier Models:** Install thrust spring (112) and shifter gear (113) in cover, with spring located over gear hub and gear timing mark to outside, facing bushing. Install shifter lever and shaft assembly (109), entering squared end of shaft into hole in gear, with shifter lever pointing upward and leather washer (110) between lever and cover bushing. Insert cotter pin in shaft to hold gear.

**1947 Models:** Install thrust spring (112) and shifter gear (113) in cover with spring located over gear hub and gear timing mark to outside, facing bushing. Install shifter lever and shaft assembly (109), entering squared end of shaft into hole in gear, with shifter lever pointing downward and leather washer (110) between lever and cover bushing. Insert cotter pin in shaft to hold gear.

**All Models:** Place shifter cam (115) in cover. Register chamfered tooth of shifter cam gear (outer end of one gear tooth is chamfered slightly) with timing mark between two teeth on shifter lever gear. After making sure shifter cam is correctly timed, install shaft (117). Be sure oil seal (118) is in place in wider groove in right end of shaft. Lock shaft in place by means of set screw (116) at left end.

Note: If when installing new shifter cam or new transmission cover, cam is tight endways, file boss in case. If cam has too much endplay, make and install a shim washer of required thickness.

### Identifying Shifter Cams:

There are two different types of shifter cams and they can be identified as follows:

Late shifter cams have part number stamped on cam cylinder, whereas cams not stamped with part number can be identified by measuring the distance between edges of cam slots at point where slots are closest to each other.

Shifter cam, Part No. 2243-36—distance between edges of cam slots at closest point is approximately 7/8". This cam applies to following transmissions—**1936—61" O.H.V. Transmission; all 1937 and 1938 Transmissions; 1940 and later 4 Speed Transmissions.**

Shifter cam, Part No. 2243-39—distance between edges of cam slots at closest point is approximately 17/32". This cam applies to following transmissions—**all 1939 Transmissions; 1940 and later 3 Speed and 3 Speed-Reverse Transmissions.**



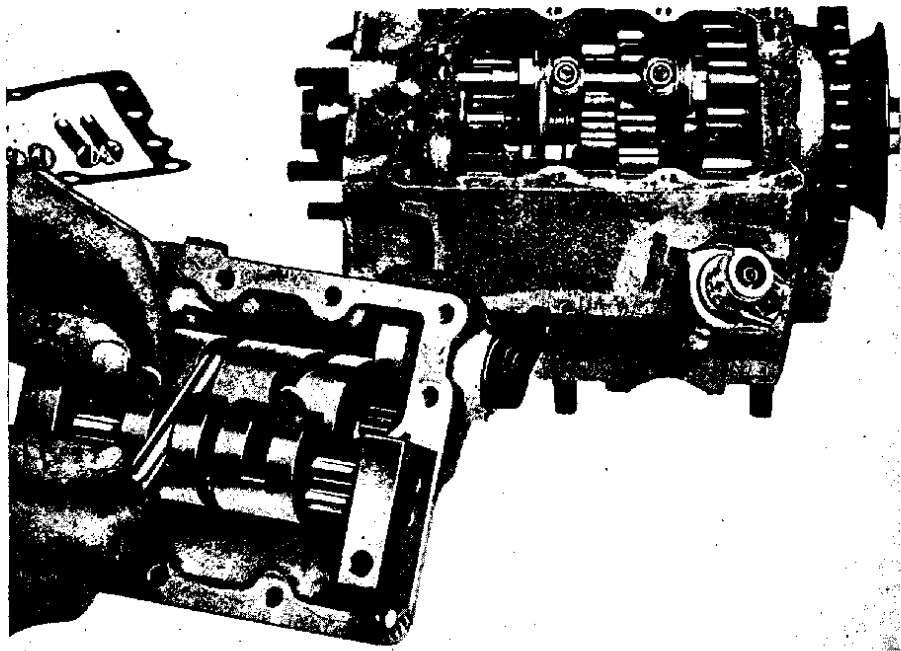

ILLUS. 127  
SETTING SHIFTER FORK GAUGE

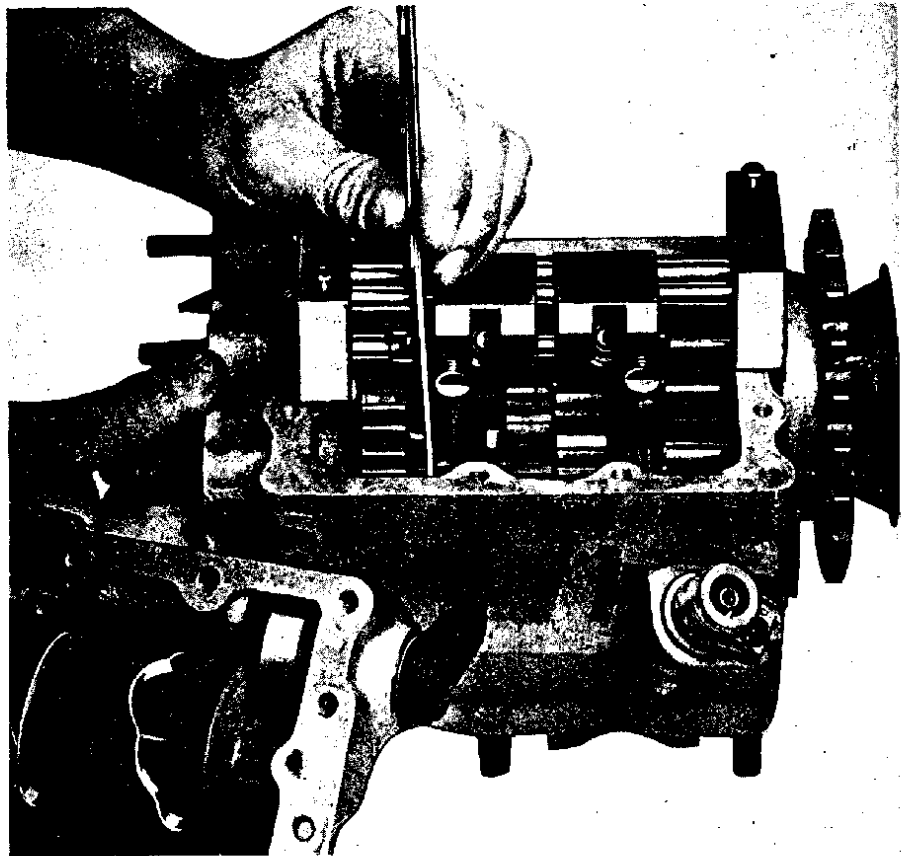

ILLUS. 128  
CHECKING ADJUSTMENT OF SHIFTING MEMBERS



## Checking Adjustment of Shifter Clutches and Sliding Gear

(To Identify Items, Refer to Illus. 121, 122 and 123)

7. Check adjustment of shifter clutches and sliding gear with Harley-Davidson special gauge, Part No. 12074-39 (see Illus. 127 and 128). Complete instructions for checking and adjusting shifter clutches and sliding gear are included with gauge.

4 *Speed Transmission*: Shifter clutch (36) must be centered between gears (18) and (39), and shifter clutch (68) must be centered between gears (65) and (71). When centered as shown in Illus. 129 and 130, mainshaft shifter clutch (36) should have about .100" clearance, both sides. Countershaft shifter clutch (68) should have about .075" clearance, both sides.

3 *Speed or 3 Speed-Reverse Transmission*: Mainshaft shifter clutch (36) must be centered between gears (18) and (39). When centered as shown in Illus. 130, shifter clutch should have about .100" clearance, both sides. Sliding gear (65) must be spaced about .055" from mainshaft gear (41) with which it engages. When checking clearance, highest points of rounded ends of gear teeth must be in exact alignment.

After correct adjustment has been made, lock shifter fork shaft (98) in place with set screw (99). Be sure shifter finger rollers (94) and (102) are in place on shifter fork fingers.

Install gasket and cover assembly, registering slots in shifter cam over shifter finger rollers and install and tighten cover screws securely. Turn sprocket and shift through all gears as a further check that transmission is properly assembled.

## Assembling and Installing Starter Assembly

(To Identify Items, Refer to Illus. 120)

8. Install release lever shaft (4) and release finger (6) in cover with plain washer (7) located between finger and bushing (8), and plain washer (9) on end of shaft and insert cotter pin (10).

To install starter crank bushings (22) and (24), press one bushing in from inner side of cover (25) so end of bushing will be just flush with bushing boss—press other bushing in from outer side of cover so end of bushing will be just flush with cover.

Install starter crank spring (19) and thrust washer (21) on starter crank and apply a film of light grease on oil seal (23) and on end of starter crank shaft before installing crank (18). With crank held in vise, wind spring by turning cover clockwise. Install starter crank gear (26) so dowel pin holds crank in normal (upward) position. Install lock washer (27) and nut (28) and tighten nut securely. Bend over one ear of nut lock washer against one side of nut. Install gasket over studs on right side of transmission case.

Before starter cover is installed, clutch release bearing (12) must be inserted into cover, with slot in outer bearing race engaging clutch release

finger (6) because starter crank gear (26) covers front edge of bearing as shown in Illus. 119. Insert push rod small diameter end into thrust bearing and insert the other end of push rod into mainshaft. With push rod serving as a pilot, move cover assembly into place, observing at the same time that groove in thrust bearing inner race and ball plunger in starter clutch align so they will be engaged when assembly is completed.

## Adjusting Shifter Cam Ball Plunger Spring Tension

(To Identify Items, Refer to Illus. 123)

In order to shift into different gear positions with minimum effort, and at same time making sure that shifter cam will remain locked in any gear position, it is essential that tension of shifter cam plunger spring (120) be correctly adjusted.

Spring tension will be correct when adjusting screw (119) is adjusted so distance from end of screw to shifter fork shaft (98) is 2-1/4".

## Installing Clutch

9. Proceed with the assembly of clutch according to instructions under "Reassembling Clutch", Page 17. Adjust clutch as per instructions under "Adjusting Clutch Spring Tension," Page 16.

Before installing clutch hub, make sure tapered end (left end) of mainshaft and tapered hole in clutch hub are clean and free from oil or grease and key is in keyway in mainshaft.

1940 and Earlier Models: Clutch hub nut (9) Illus. 8, cannot be installed until after clutch is reassembled.

1941 to 1947 Models: Make sure clutch hub nut (12) is securely tightened, and one lip of lock washer (25) is bent up against one side of nut (see Illus. 9 and 137.)

All Models: Before installing clutch shell and sprocket, apply a few drops of oil or a very small amount of grease to ball bearing.

## Installing Transmission in Chassis

Installation is a reverse procedure of removal. See "Removing Transmission from Chassis", Page 126.

After transmission has been installed, and transmission sub-mounting plate bolts and transmission mounting stud nuts have been securely tightened, check adjustment of chains, rear brake, clutch control and shifter control and adjust if needed.

CAUTION: Be sure transmission is filled to level of filler opening with oil of the same grade used in engine. See "Transmission Lubrication," Page 144.

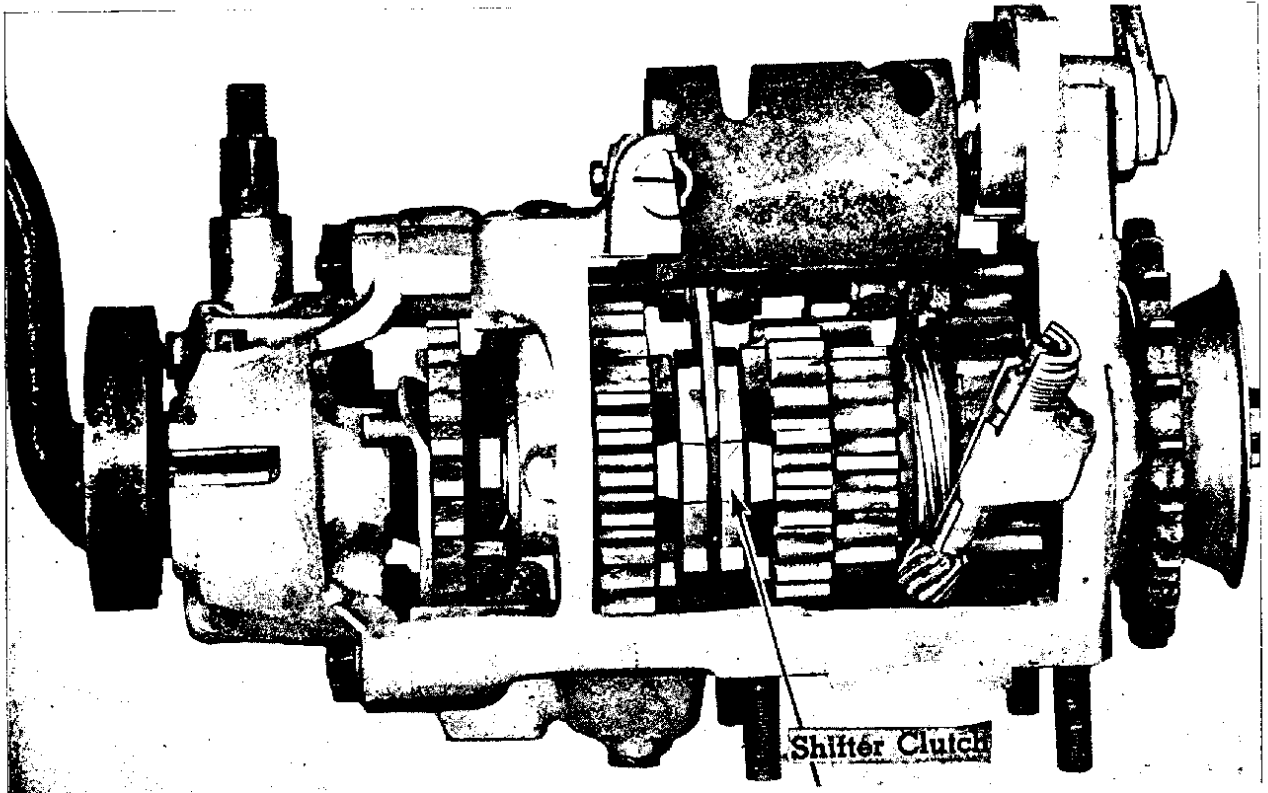

ILLUS. 129  
CUT-AWAY FRONT VIEW OF TRANSMISSION IN "NEUTRAL" POSITION

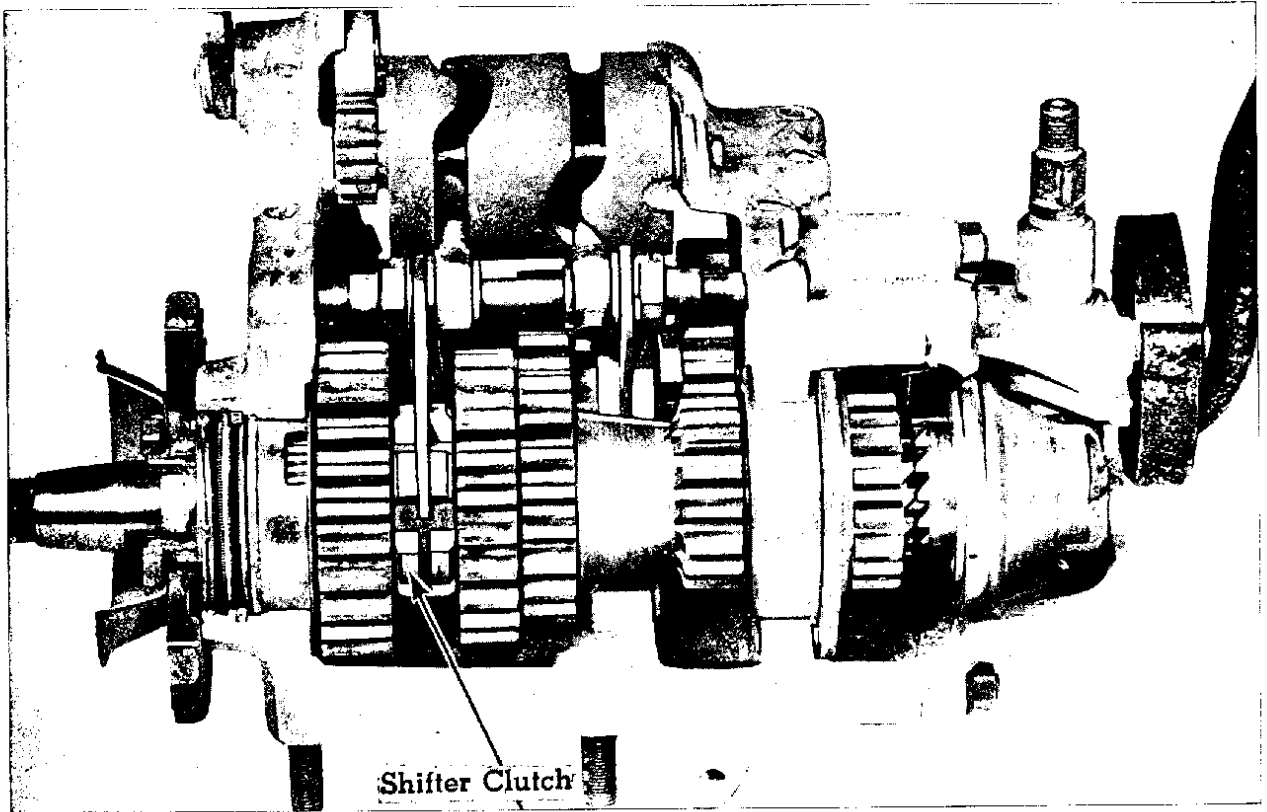

ILLUS. 130  
CUT-AWAY REAR VIEW OF TRANSMISSION IN "NEUTRAL" POSITION

## Renewing Main Drive Gear Oil Seal

To do a satisfactory job of renewing oil seal requires a special tool.

It is not recommended practice to drive in an oil seal, as doing so may damage the seal. A damaged or improperly installed seal will result in oil leakage.

Complete instructions for renewing oil seal are included with Harley-Davidson oil seal tool, Part No. 12734-42. See Illus. 131, 132, 133, 134 and 135.

## TRANSMISSION LUBRICATION

After initial servicing of new motorcycle, (see Page 10), check oil level every two weeks, or every 1000 miles, whichever comes first, and add oil if necessary. Fill to level of filler opening. Use Harley-Davidson "Regular Heavy" engine oil in summer and "Medium Heavy" oil in winter. In extremely cold weather, if shifting becomes difficult due to transmission oil becoming congealed to some extent, thin with a small amount of kerosene.

Motorcycle should be standing straight up, not leaning on Jiffy Stand, when adding oil to transmission.

### Illustrating Use of Main Drive Gear Oil Seal Tool

(Instructions for use furnished with tool)

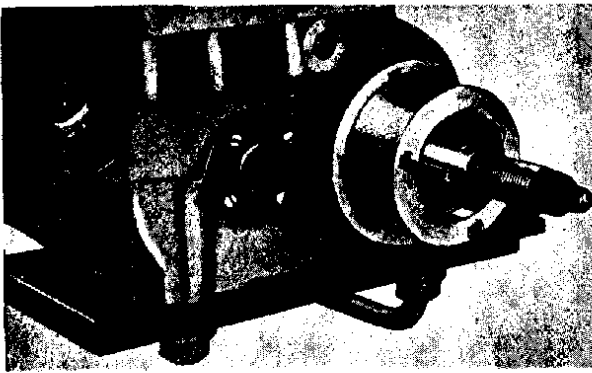

ILLUS. 131  
CENTER PUNCHING OIL SEAL AS GUIDE FOR DRILLING  
HOLES PREPARATORY TO REMOVING SEAL

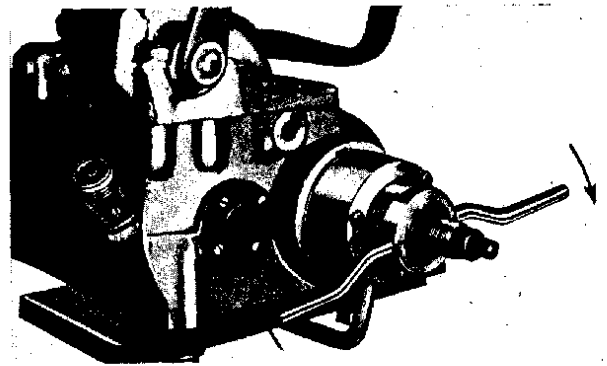

ILLUS. 132  
REMOVING OIL SEAL

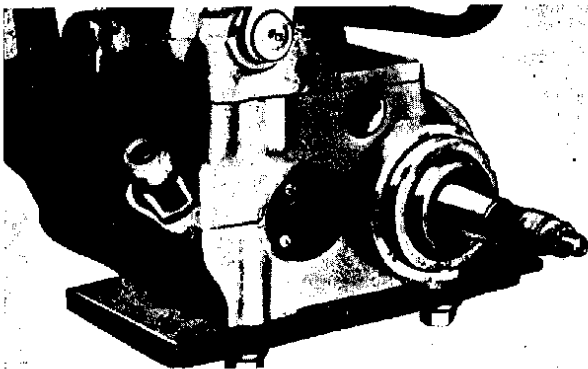

ILLUS. 133  
LOCATING OIL SEAL PREPARATORY TO INSTALLING

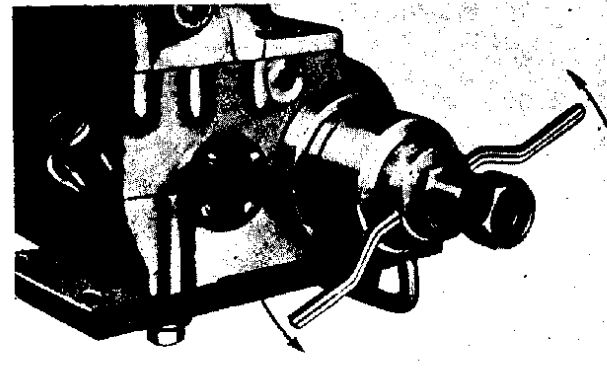

ILLUS. 134  
INSTALLING OIL SEAL

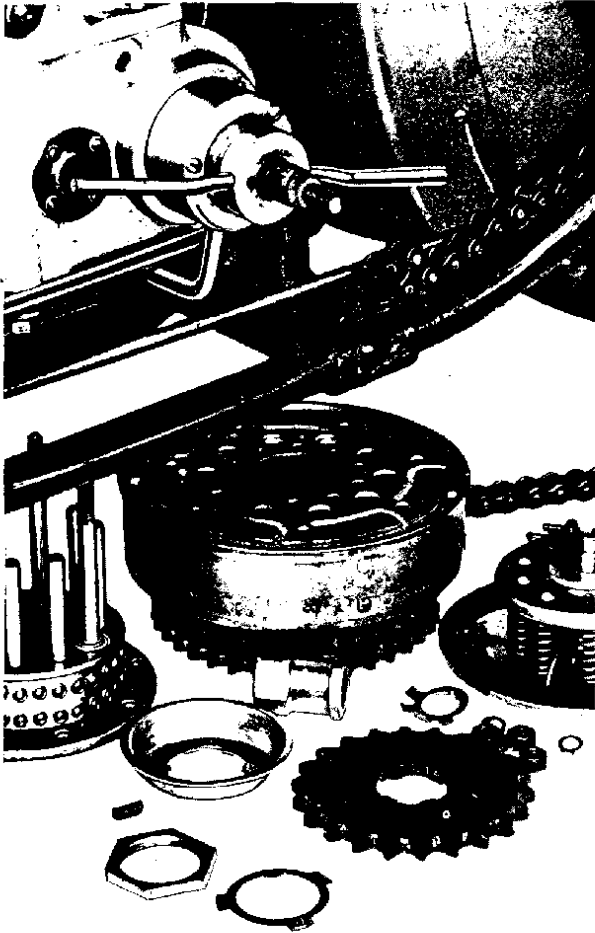

ILLUS. 135  
 REPLACING MAIN DRIVE GEAR OIL SEAL WITH TRANSMISSION  
 IN CHASSIS  
 (See "Renewing Main Drive Gear Oil Seal," Page 144)

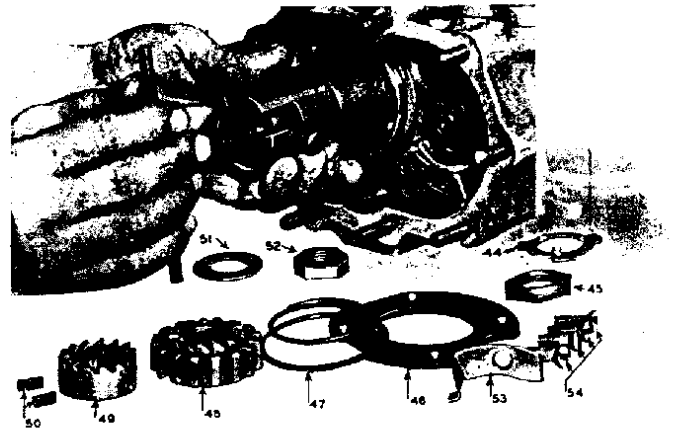

ILLUS. 136  
 REMOVING WORN OR DAMAGED MAINSHAFT BALL BEARING  
 (To Identify Items, Refer to Illus. 122)

Note: Instructions for replacing mainshaft ball bearing are included with Harley-Davidson starter clutch and mainshaft ball bearing puller, Part No. 12737-43.

CAUTION: Tool is intended to be used for removing a worn or damaged bearing from a transmission assembly in chassis. If transmission is to be completely disassembled but bearing is still in good condition and usable, it is not necessary to use this tool for bearing removal, and it should not be used for this purpose as engaging it will damage bearing.

## SUMMARY OF TRANSMISSION SPECIFICATIONS (Fitting and Adjusting)

*All Roller Bearings:* .0006" to .001"; .0008" preferred.

*Mainshaft in Main Drive Gear Bronze Bushing:* .002" to .003" loose; .0025" preferred.

*Countershaft Gear Endplay:* .008" to .012"; .010" preferred.

*Main Drive Gear and Sprocket Assembly Endplay:* .005" to .014"; .010" preferred. See Item (12) under "Transmission Assembly—Main Drive Gear Group," Page 131.

*Shifter Cam Endplay:* Free to .005". If when installing new shifter cam or new transmission cover, cam is tight endways, file boss in case. If cam has too much endplay, make and install a shim washer of required thickness.

*Mainshaft Shifter Clutch Side Clearance:* about .100" both sides, when shifter clutch is centered.

*Countershaft Shifter Clutch Side Clearance:* about .075" both sides, when shifter clutch is centered.

*Sliding Gear Side Clearance:* about .055" between teeth of sliding gear and mainshaft gear with which it engages. Highest points of rounded ends of gear teeth must be in exact alignment when checking clearance.

Note: Complete instructions for checking and adjusting shifter clutches and sliding gear are included with Harley-Davidson shifter fork gauge, Part No. 12074-39.

*Clutch Spring Tension Adjustment:*

*1940 and Earlier Model Clutch*—Distance from face of spring collar to shoulder on thrust plate mounting studs should be 3/8".

*1941 to 1947 Model Clutch*—Distance from inner edge of spring collar to surface of outer disc should be 31/32".

## CLUTCH DISASSEMBLED

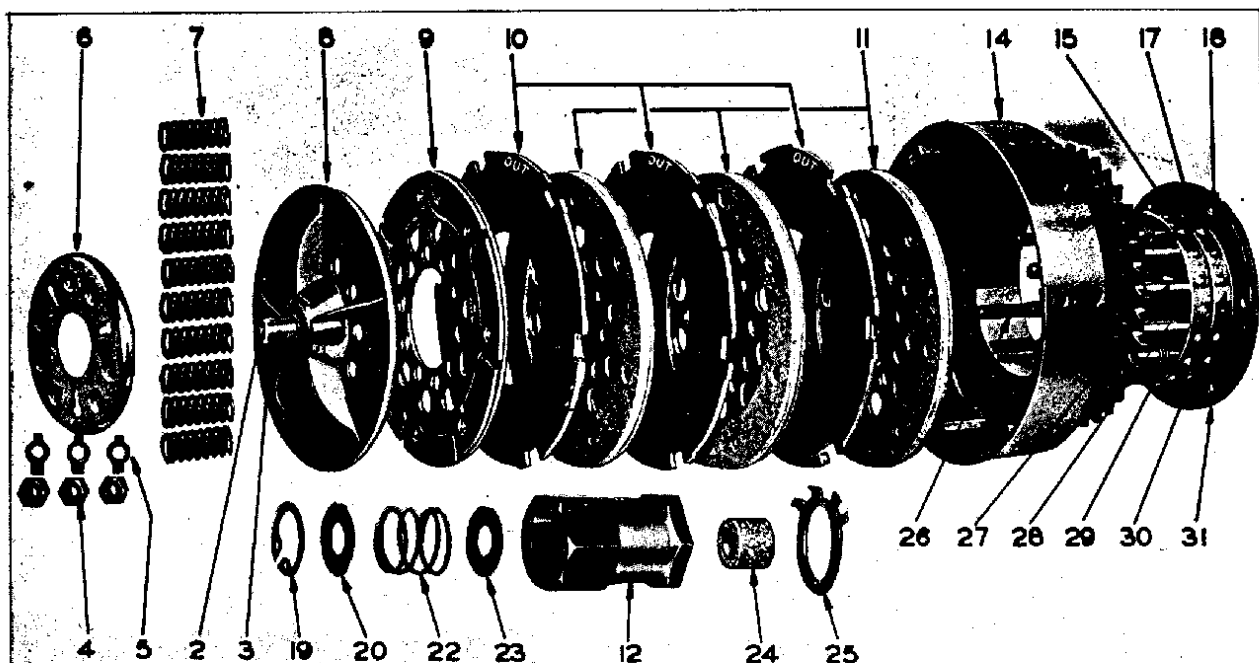

ILLUS. 137  
CLUTCH DISASSEMBLED—(1941 TO 1947 MODELS)

## CLUTCH ASSEMBLY

1941 to 1947 Models

(Item Numbers Refer to Illus. 137)

ITEM	NUMBER USED	PART NUMBER	NAME
2	1	2463-41	Push Rod Adjusting Screw
3	1	2465-41	Push Rod Adjusting Screw Lock Nut
4	3	0117A	Spring Tension Adjusting Nut
5	3	2512-41A	Spring Tension Adjusting Nut Lock
6	1	2505-41	Spring Compression Collar
7	10	2511-41	Clutch Springs
8	1	2479-41	Releasing Disc
9	1	2481-41B	Sprung Steel Disc with Lining
10	3	2487-41	Plain Steel Disc
11	3	2481-41	Lined Disc
12	1	2275-41	Clutch Hub Nut (left thread)
14	1	2039-41	Sprocket Complete with Disc Spline Ring
15	36	2472-41B	Ball— $\frac{1}{32}$ "
17	1	2483-41	Hub Disc Lining
18	10	2485-41	Lining Rivet
19	1	2460-41	Push Rod Oil Seal Spring Ring
20	2	0227	Oil Seal Spring Plain Washer (same as Item 23)
22	1	2459-41	Push Rod Oil Seal Spring
23	See Item 20	.....	.....
24	1	2461-36	Push Rod Cork Oil Seal
25	1	2471-41	Clutch Hub Nut Lock Washer
26	3	2477-41	Stud
27	7	2478-41	Pin
28	1	2475-41	Bearing Retaining Plate
29	3	2474-44	Bearing Plate Retaining Spring
30	1	2473-41	Ball Bearing Retainer
31	1	2472-41	Clutch Hub Complete (includes Items 15, 17, 18, 26, 27, 28, 29 and 30)



## WHEELS, HUBS AND TIRES.

Wheels normally require little attention other than ample lubrication of hubs. See "Lubrication Chart," Page 9. Occasionally, set motorcycle on rear stand, block up front end of motorcycle to raise front wheel, and check adjustment of hubs. Adjustment is all right when only a small amount of side shake can be found at rim of wheel. Also check spokes and tighten any found loose.

### Removing Front Wheel

Set motorcycle on rear stand; then raise front end of motorcycle high enough to permit removing wheel; support motorcycle by means of front stand, or by suitable blocking underneath frame.

If wheel is to be taken out just for tire or wheel service, and then reassembled in front, it is not necessary to detach from brake drum, as required when removing rear wheel. Detachment of wheel from brake drum is necessary only when wheel or brake drum is to be replaced or wheel interchanged. To detach wheel from brake drum, remove the five wheel mounting socket screws that secure wheel to brake drum. Use Harley-Davidson special wrench, Part No. 12025-35, or wrench furnished in tool kit.

Take out axle and remove spacer from between hub and right side fork rocker. Wheel, with or without brake drum attached, is then free to come out.

When replacing wheel, reverse operations of removal. It is important that wheel mounting socket screws be very tight to avoid any possibility of wheel working loose in service and consequently damaging hub flange.

### Removing Rear Wheel

Set motorcycle on rear stand and loosen and raise end of mudguard. Remove the five wheel mounting socket screws that secure wheel to brake drum. Use Harley-Davidson special wrench, Part No. 12025-35, or wrench furnished in tool kit. Wrench can be inserted only directly to the rear of axle, so wheel will have to be turned to bring each screw to this position. Apply rear brake and lock it by shifting brake rod lock back against footboard support, or with pedal lock if equipped with one. (Brake rod lock is a wing nut clamp on rod near pedal. Stoplamp control wire is hooked to it.) Take out axle and remove spacer from between wheel hub and right side of frame. Wheel is then free to come out.

When replacing wheel, reverse operations of removal but securely tighten the five wheel mounting socket screws before tightening axle nut. To avoid any possibility of wheel working loose in service and consequently damaging hub flange, it is important that wheel mounting socket screws be very tight.

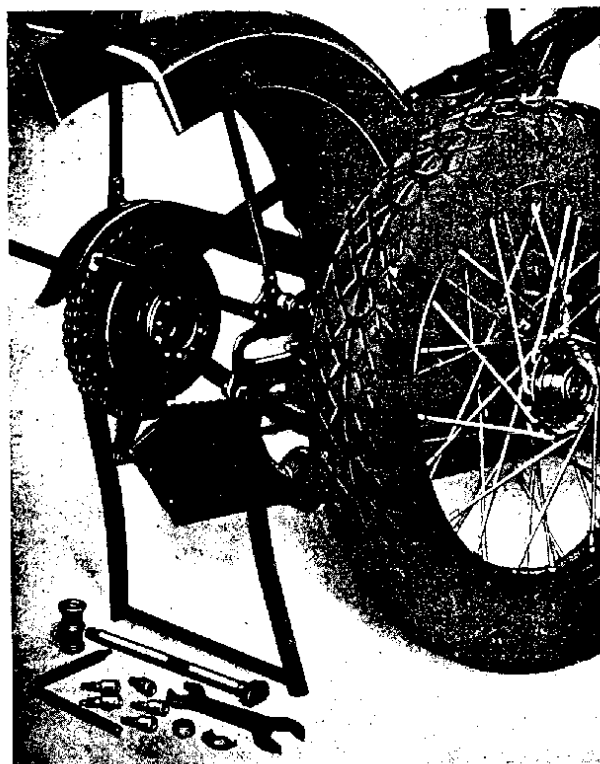

ILLUS. 136  
REAR WHEEL REMOVED

### Removing Sidecar Wheel

Raise wheel by blocking up underneath sidecar chassis. Loosen nut that secures front lower end of mudguard to sidecar step. Loosen nut (several turns) that secures mudguard inner brace clip to bracket. Remove nut that secures mudguard outer brace clip to axle extension nut, and hinge mudguard forward, making sure lamp wiring (if sidecar is equipped with lamp) has sufficient slack.

Remove extension nut, washer and axle nut. Wheel can now be pulled off axle with brake drum attached. Detachment of wheel from brake drum is necessary only when wheel or brake drum is to be replaced or wheel interchanged. To detach wheel from brake drum, remove the five wheel mounting socket screws that secure wheel to brake drum. Use Harley-Davidson special wrench, Part No. 12025-35 or wrench furnished in tool kit.

When replacing wheel, reverse operations of removal. It is important that wheel mounting socket screws be very tight to avoid any possibility of wheel working loose in service and consequently damaging hub flange.

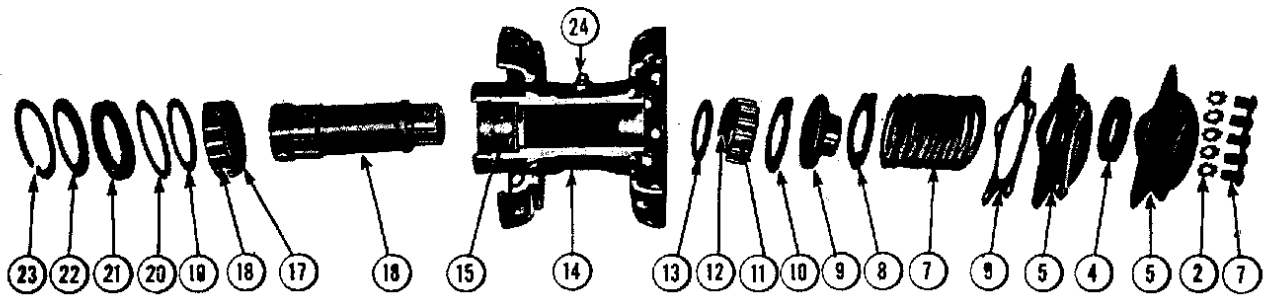

ILLUS. 139  
WHEEL HUB DISASSEMBLED

### WHEEL HUB ASSEMBLY

(Item Numbers Refer to Illus. 139 and 140)

ITEM	NUMBER USED	PART NUMBER	NAME
1	5	050	Thrust Bearing Cover Screw
2	5	0363	Thrust Bearing Cover Screw Lock Washer
3	1	3972-35	Thrust Bearing Outer Cover
4	1	3976-35	Cork Grease Retainer (right side)
5	1	3974-35	Thrust Bearing Housing
6	1	3975-35	Thrust Bearing Housing Gasket
7	Varies	3980-35	Thrust Bearing Adjusting Shims (each shim .002" thick; use as many as necessary to adjust so that sleeve (9) has .003" to .005" endplay)
8	2	3982-35	Thrust Washer (same as Item 10)
9	1	3978-35	Thrust Bearing Sleeve
10	See Item 8		
11	26	2289-25	Bearing Roller—Standard size .250" x .490"; available from .001" undersize to .001" oversize in steps of .0002" (same as Item 18). Select size of rollers that will give .001" to .0015" clearance.
12	1	417-30	Roller Retainer (right side—12 rollers)
13	1	3982-39	Roller Retainer Thrust Washer (right side)
14	1	3960-36	Hub Shell
15	1	3981-39	Roller Retainer Thrust Collar (left side—pressed into hub shell)
16	1	3963-35	Hub Inner Sleeve
17	1	3967-35	Roller Retainer (left side—14 rollers)
18	See Item 11		
19	1	3966-39	Roller Bearing Washer
20	2	3965-35	Roller Bearing Spring Lock Ring (same as Item 23)
21	1	3968-35	Cork Grease Retainer (left side)
22	1	3970-35	Cork Retaining Washer
23	See Item 20		
24	1	0344	Grease Fitting

### Servicing Wheel Hub

(To Identify Items, Refer to Illus. 139 and 140)

To take up only excessive sideplay that may develop, it is not necessary to take hub completely apart. Simply remove screws (1) and complete thrust bearing assembly comes off end of hub and can be taken apart. One or more shims (7) as required can then be added, and the assembly re-assembled on hub. Be careful about adding too many shims and thus binding thrust sleeve (9). It must still be free with cover screws (1) securely tightened. It is best to leave cork grease retainer

(4) out of thrust assembly while determining correct adjustment of thrust sleeve, and put it back in when readjustment is completed. Cork grease retainer interferes to some extent with free movement of thrust sleeve and, therefore, makes it difficult to determine whether or not sleeve is altogether free between thrust washers (8) and (10).

Excessive radial (up and down) play in wheel hub bearings, due to wear, can be taken up by fitting oversize rollers (11) and (18). To take hub completely apart for attention to roller bearings, first remove thrust assembly as explained above. Next, remove spring lock ring (23), washer (22), cork

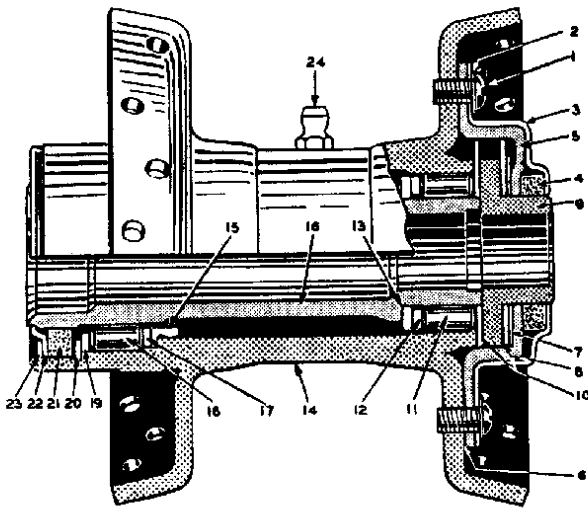

ILLUS. 140  
WHEEL HUB ASSEMBLY

grease retainer (21) and pull out inner sleeve (16). Rollers and retainers can then be taken out. It is necessary to remove spring lock ring (20) and washer (19) before brake side bearing can be removed.

When trying for roller bearing clearance (.001" to .0015"), bearings must be free from grease or oil. After correct size rollers have been selected, reassemble hub in reverse order of disassembly.

When reassembling hub, apply a thin coating of Harley-Davidson grade "A" grease to rollers, races and thrust washers. After final assembly, inject in wheel hub, 1 oz. Harley-Davidson grade "A" grease, with a grease gun.

In fitting oversize rollers, care must be exercised to avoid fitting too tight. With hub assembled, roller bearings must turn freely and have slight play or shake.

### Care of Wheels and Tires

Good handling of a motorcycle at any speed and maximum tire mileage go hand in hand with attention given wheels and tires.

Too many motorcycle riders and mechanics are pretty much engine and horsepower minded, and as a result are inclined to consider wheels and tires something secondary to be given attention only after something fails, or serious solo motorcycle handling irregularities are experienced at high speed.

Here and there a rider transposes his tires to avoid excessive irregular wear of front tire tread and to equalize tire wear, but most riders don't make this a practice because they don't realize it is a must, if high speed solo handling is to be kept at its best. The larger the tire size the more essential it is that this practice be followed. A tire kept in continuous solo motorcycle front end service long enough to allow tread to wear quite noticeably irregular and peaked, is very likely to set up a

high speed weave, especially if over-inflated.

At regular intervals of approximately 3000 miles or at anytime a solo motorcycle develops handling irregularities at high speed, check as follows and give attention as needed:

#### CHECK FOR —

- 1—Loose wheel axle nuts.
- 2—Excessive wheel hub bearing play.
- 3—Loosened spokes.
- 4—Rear wheel alignment in frame and with front wheel.
- 5—Rims and tires too much out-of-true sideways. (Tire run-out should not be more than 3/64").
- 6—Rims and tires too much out-of-round or eccentric with hub. (Tire run-out should not be more than 3/32".)
- 7—IRREGULAR OR PEAKED FRONT TIRE TREAD WEAR; IF A SOLO MOTORCYCLE THAT DOESN'T SEEM TO HANDLE JUST RIGHT AT HIGH SPEED, DETERMINE MILEAGE SINCE TIRES WERE LAST TRANSPOSED. IF MILEAGE IS FOUND TO BE 2500 OR MORE, TRANSPOSE FRONT AND REAR WHEELS AND TIRES EVEN THOUGH IRREGULAR WEAR OR PEAKING OF FRONT TREAD IS NOT VERY NOTICEABLE.
- 8—Tire inflation as per inflation pressure chart, Page 3. Do not over-inflate.
- 9—Tire and wheel balance, if balancing equipment is available. Static balancing will be satisfactory, if dynamic balancing facilities are not at hand.
- 10—Steering head bearings for correct adjustment and any indication of pitted ball races.
- 11—Ride control or shock absorber for normal functioning.
- 12—Steering damper for good working order and adjustment so that it can be applied easily and gradually to any desired steering friction. If steering damper torque arm is found with more than .005" side lash where the rear end of arm engages frame head, this should be corrected. Every motorcycle rider should be made to understand his steering damper is an important safety appliance with which steering is steadied when driving at higher speeds. It, therefore, must be kept in good working order and adjustment, and it should be used.

With attention given as outlined you will in nearly every case find any high speed handling faults corrected. The possible exception will be the case where there is serious frame or fork misalignment or maybe a tire in extremely bad condition, which should be replaced. REMEMBER, TRANSPOSING WHEELS AND TIRES APPROXIMATELY EVERY 3000 MILES AND INFLATING NO HIGHER THAN THE RECOMMENDED PRESSURE ARE OF FIRST IMPORTANCE. IN MANY CASES YOU WILL FIND THAT THIS ATTENTION ALONE APPLIED TO A

**SOLO MOTORCYCLE THAT DEVELOPS FAULTY HANDLING AT HIGHER SPEEDS WILL GAIN THE DESIRED RESULTS.**

It is advisable to rebalance wheels and tires, at least statically, whenever casing and/or tube may be replaced.

procedure with balance of spokes.

7. Turn rim and hub over. Repeat operations 2, 3, 5 and 6, except in operation 3 swing spokes clockwise and in operation 5 swing spokes counter-clockwise. Note: Outer spokes on both sides point in same direction.

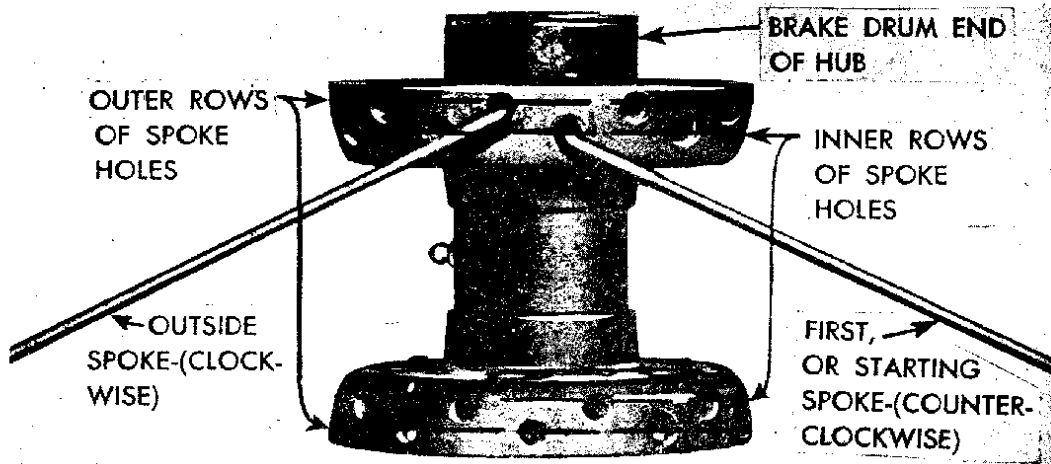

ILLUS. 141  
INSERTING SPOKES IN WHEEL HUB

**Spoking Wheel**

Front, Rear and Sidecar—5.00" x 16" Wheel and 4.00" x 18" Wheel

(Refer to Illus. 141 and 142)

Spoke holes in hub flanges are in two rows around flange—ten inner row holes and ten outer row holes in each flange.

All spokes must be inserted from inside of flange.

1. Place hub on bench with brake drum end of hub up.
2. Insert spokes in ten inner spoke holes of brake side flange.
3. Swing loose end of spokes counter-clockwise as far as hub will allow without turning hub.
4. Place rim over hub (with tire valve hole 90° to 180° from hub grease fitting) and insert spokes in upper row of holes in rim that angle in same direction as spokes. Note: 18" rim is placed over hub, either side down; 16" rim is placed over hub with tire valve hole down (opposite brake drum end of hub).
- Just start nipples on spokes as they are inserted in rim.
5. Insert spokes in outer ten holes of flange and swing spokes clockwise.
6. Select any outer spoke, cross it over four inner spokes (1, 2, 3 and 4) and insert spoke in nearest upper rim hole and start nipple. Follow same

**Truing Wheel**

1. Install truing arbor in wheel hub and place wheel in Harley-Davidson special truing stand, Part No. 12028-X. Secure arbor nuts so that hub will turn on its bearings.

2. Turn each nipple on just far enough to cover spoke threads.

3. Start at valve hole and tighten all nipples three full turns each using Harley-Davidson special nipple wrench, Part No. 12033-39. If further tightening is needed to pull spokes snug, tighten all nipples one full turn at a time until spokes are snug.

4. Check rim for centering sideways with hub, for running true sideways and concentricity. Centering rim sideways with hub and truing rim sideways must be done as one operation.

A. Rim must be properly centered sideways in relation to hub for correct alignment and "tracking" of front and rear wheels. Illus. 143 shows method of using a straight edge to determine correct sideways centering of wheel rim. Measurement shown in Illus. 143 applies to 18" wheels. Straight edge should be a perfectly straight metal bar. If rim is too close to straight edge, loosen all nipples on brake side and tighten all nipples on opposite side same amount. If rim is too far from straight edge reverse operations.

B. 16" Wheel (5.00" Tire)—Lay straight edge across rim on brake side and measure the distance from straight edge to brake side spoke flange of hub. When rim is correctly centered this distance will be 11/64".

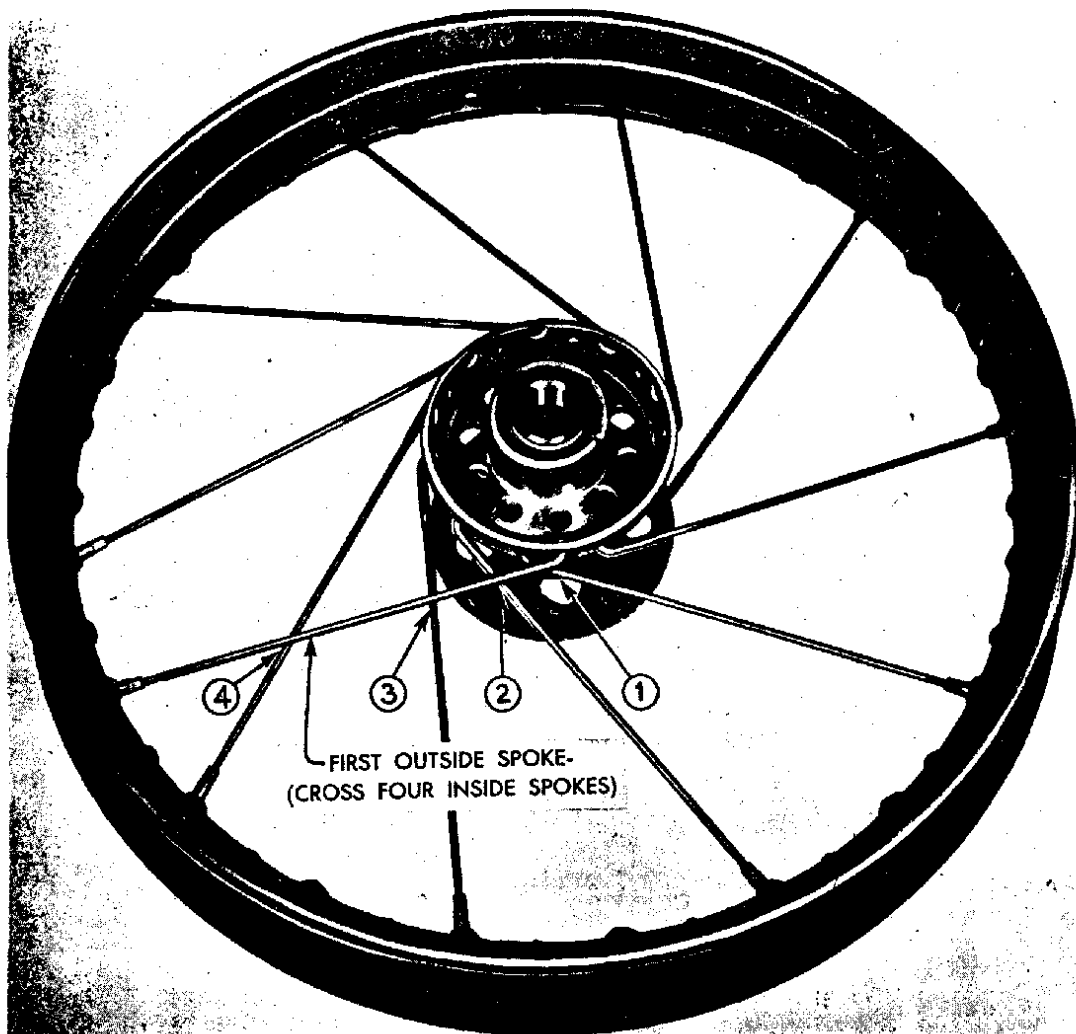

ILLUS. 142  
SPOKING WHEEL

C. 18" Wheel (4.00" Tire)—Lay straight edge across brake side spoke flange of hub and measure distance from straight edge to rim. When rim is correctly centered, this distance will be 1/4".

D. Adjust truing stand gauge to side of rim as shown in Illus. 144, so rim at highest point will strike gauge as wheel is rotated slowly. Loosen nipples at highest point of rim on gauge side, and tighten nipples on opposite side the same amount. Repeat this operation until rim runs true sideways. Reverse loosening and tightening of nipples, as explained above if rim moves too far away from gauge. After each loosening and tightening of spokes check rim in relation to hub as explained under paragraph B or C. Rim should be trued to within 1/32" sideways.

E. After rim has been centered sideways with wheel hub and runs true sideways, check it for concentricity. Adjust truing stand gauge to circumference of rim as shown in Illus. 145. If rim runs eccentric (out of round) nipples must be loosened

at points rim does not contact gauge and nipples tightened at points rim contacts gauge. Amount nipples are to be loosened or tightened is determined by the amount rim runs eccentric. Rim should be trued to within 1/32" concentrically.

5. After above operations have been checked and corrected, start at valve hole and tighten nipples one turn at a time all the way around rim until spokes are normally tight. While tightening nipples, repeatedly check rim with gauge according to instructions under operation 4.

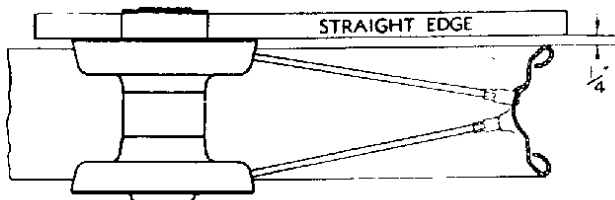

ILLUS. 143  
WHEEL RIM CORRECTLY CENTERED (4.00" TIRE RIM)



After all nipples have been pulled up until spokes are normally tight and wheel is true, or nearly so, seat each spoke head into hub flange with a sharp blow, using a flat nose punch and hammer. Then retighten all nipples and finish truing wheel. This method allows spokes to be drawn tighter at the start and prevents possibility of spokes loosening, due to spoke heads seating into flange, after wheel is put into service.

**CAUTION:** Do not tighten spokes too tight or nipples may draw through rim, or hub flanges may be distorted. If spokes are left too loose, they will continue to loosen when wheel is put in service.

6. File or grind off ends of any spokes protruding through nipples to prevent puncturing tube when tire is mounted.

### Wheel Spokes, Rims and Nipples

5.00" x 16" Wheel—spoke length 6-23/32", diameter .161", Part No. 3943-40. Nipple Part No. 3947-29. Rim Part No. 3940-40.

4.00" x 18" Wheel—spoke length 8-5/32", diameter .161", Part No. 3943-36. Nipple Part No. 3947-29. Rim Part No. 3940-35.

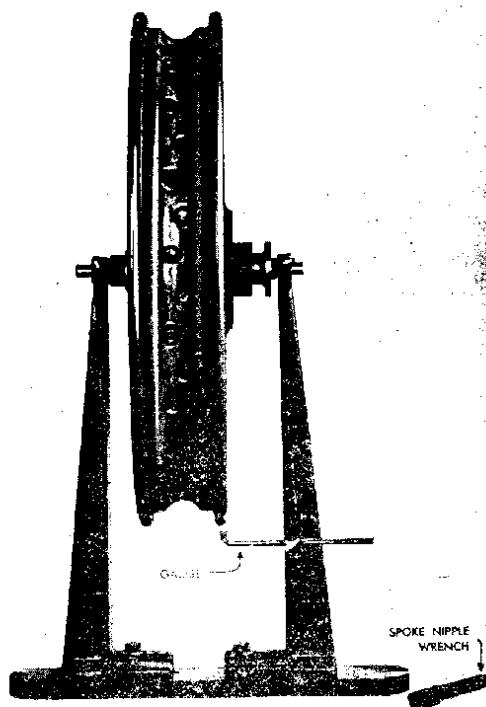

ILLUS. 143  
TRUING RIM TO BE CONCENTRIC WITH WHEEL HUB

### Removing and Installing Tires

Wheel rims are of the drop-center type, having a depression or "well" in center of rim. Rim-well, being smaller in circumference than rest of rim, allows one casing bead to fit loosely in it while other bead is being worked over edge of rim. Bear in mind the importance of keeping one bead in the well while other bead is being worked onto or off of rim.

### Removing Tire From Rim

1. Remove wheel; lay wheel on its side. (See "Removing Front Wheel," "Removing Rear Wheel" and "Removing Sidecar Wheel," Page 147.)
2. Remove valve cap and valve core to free all air from tube. Remove valve stem nut (18" rim).
3. Loosen both beads from rim flanges by stepping on sides of tire or by using a tire tool. Stand or kneel on tire opposite valve to push bead into rim-well.
4. Using tire tools (not sharp instruments) start upper bead over edge of rim at valve. Don't use force when starting bead over edge of rim with tire iron, because bead wires may be broken or stretched and tire ruined. Carefully remove inner tube before attempting to remove second bead.
5. Push lower bead into rim well on one side and insert tire iron on opposite side and pry bead over flange. After a portion of second bead is started over rim edge, tire can be further removed from rim without aid of tire iron.

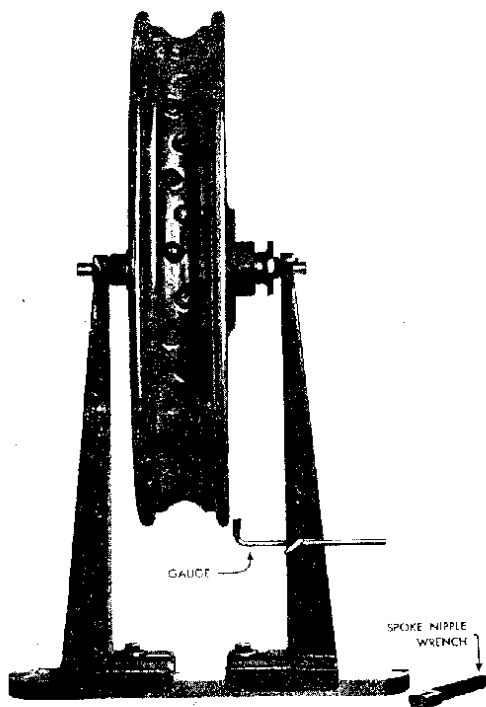

ILLUS. 144  
TRUING RIM SIDWAYS AND CENTERING WHEEL HUB

6. It is not always necessary to completely remove casing from rim. Removing one side only, allows inner tube to be removed and reinstalled and also allows inside of casing to be inspected.

### Mounting Tire on Rim

1. Before installing tube in tire, all dust and dirt, particularly hard particles which might chafe an inflated tube, must be carefully removed. Wipe tube and inside of tire thoroughly with clean, dry cloth. If rim is dirty or rusty clean it with a stiff wire brush. Be sure to examine a used tire carefully for fabric injuries which, if neglected, will damage tube.

2. Before mounting tire, see that rubber rim strip is in place in rim-well, and that rim strip valve hole registers with valve hole in rim.

Tire balance mark on Firestone tires is a red triangle and on Goodyear tires a red dot.

#### Natural Rubber Tube:

3. Insert tube in tire, (placing valve at tire balance mark) and inflate just enough to round it out. With wheel lying flat, place tire on rim and align valve with hole in rim.

4. Push bottom bead into rim-well near valve and hold in well while forcing remaining portion of bead over rim flange with a tire tool.

5. Spread tire and insert valve through hole in rim.

6. Force upper bead over rim flange and into well at point opposite valve. Stand or kneel on this side of tire to hold it in well and pry remaining portion of tire over rim flange. While forcing

bead over rim flange, keep as much bead as possible in rim-well. Be careful not to damage beads or pinch tube. Inflate tire to recommended pressure and check valve for leak. See "Tire Inflation Pressures," Page 3.

#### Synthetic Rubber Tube:

Synthetic tubes do not have the same stretching qualities as natural rubber tubes have. They are much more inclined to split and tear; therefore, synthetic tubes must be free from all strains and stresses after installing and inflating for operation.

7. Dust tube, inside of tire and rim strip that covers spoke ends, with soapstone powder. Insert tube in tire, (placing valve at tire balancing mark) and inflate just enough to round it out. Using a brush or cloth swab, apply a solution of neutral vegetable oil soap for lubricating tube and inside of tire about a third of the way up from bead toe; also face of rim strip that covers spoke ends, rather than to depend entirely upon soapstone, because soap suds lubricate more effectively and better assure tube properly shaping itself to rim-well without undue adhesion, stretch or strain. Do not allow soap solution to run into crown of tire. If, however, no vegetable oil soap is available, use soapstone powder more freely. Be careful, however, not to use so much that it accumulates in casing.

When mounting tire on rim, follow standard procedure as outlined under "Natural Rubber Tube." However, after inflating to recommended pressure, completely deflate to smooth out any wrinkles in tube and allow tube to find its place, free from strain or stress. Again inflate to recommended pressure and check valve for leak.

8. Reinstall wheel.

## REMOVING AND INSTALLING FORKS

Spring fork only can be removed and replaced, or complete fork assembly (spring and rigid fork) can be removed and replaced as a unit.

### Removing Spring Fork

1. Set motorcycle on rear stand.
2. Remove spring rod lock nuts (acorn-type).
3. Sit on front mudguard, or otherwise provide weight, to compress fork cushion (lower) springs. The spring rod larger nuts can then be easily removed, freeing upper recoil and upper bumper springs for removal.
4. Free lower end of horn assembly from horn bracket on mudguard.
5. If motorcycle is equipped with ride control, free the two eye bolts (10) and (12) Illus. 153, from spring fork crown; if equipped with shock absorber, remove the two bolts (T), Illus. 152.
6. If motorcycle is equipped with mudguard lamp, disconnect lamp wire from terminal on ignition-light switch and tie a piece of string approximately 30" long to wire terminal. Pull wire

out of loom and untie or cut string, allowing it to extend through each end of loom. String will be used when reassembling to pull wire back through loom.

7. Raise front end of motorcycle high enough to permit removing front wheel and front mudguard—support motorcycle by means of suitable blocking underneath frame.
8. Remove front wheel. See "Removing Front Wheel," Page 147.
9. Remove brake assembly from left rocker plate, after disconnecting brake shackle from rigid fork.
10. Remove front mudguard, after removing nuts and locks from rocker plate rear studs, and the two bolts securing mudguard to rigid fork.
11. Remove rocker plate studs and rocker plates assembled.
12. Remove spring fork from motorcycle.

### Installing Spring Fork

13. Place buffer springs and lower cushion springs on spring rods. Apply grease to rods. Pass rods

up through spring rod bushings in rigid fork bracket. Bind lower end of spring fork to lower end of rigid fork with a strap or piece of heavy wire, to prevent forks from separating while compressing cushion springs.

Note: Before installing spring fork note type of rigid fork used. Earlier type rigid fork stem upper end and fork side upper ends were on same center line, whereas, center line of later type rigid fork stem upper end is  $\frac{3}{8}$ " to rear of fork side center line.

There are three different spring forks which can be used with rigid forks as follows:

Any spring fork used with an earlier type rigid fork can be installed with either side of fork crown facing rear.

If earlier type spring fork (fork crown not milled, approximately  $\frac{3}{8}$ " wide at center lower section) is to be used with later type rigid fork it will be necessary to remove sufficient metal from one side of fork crown lower center section to allow clearance for steering damper steel disc when fork is installed.

If later type spring fork (one side of fork crown milled) is to be used with later type rigid fork, install spring fork with milled side facing rear to allow clearance for steering damper steel disc.

If latest type spring fork (fork crown not milled approximately  $\frac{5}{8}$ " wide at center lower section) is to be used with later type rigid fork, spring fork can be installed either way.

14. Insert two bolts in rigid fork bracket which mount the mudguard. Place a rod about 8" long and  $\frac{1}{2}$ " or larger diameter, on and across rigid fork brackets, resting it against the two bolts inserted in fork brackets. This rod will serve as a pry base for the leverage bar when compressing cushion springs. With a leverage bar about 18" long, anchored on top of the pry base rod and under the spring fork, lift upward to compress cushion springs sufficiently to install one of the rocker plates—then install the other rocker plate.
15. Install front mudguard.
16. Install front brake assembly on left rocker plate, and connect brake shackle to rigid fork.
17. Install front wheel.
18. Install upper bumper springs and upper recoil springs on the spring rods.
19. Remove blocking from underneath motorcycle frame.
20. Sit on mudguard to compress fork cushion (lower) springs. Tighten the two larger spring rod nuts sufficiently to provide  $\frac{7}{16}$ " thread for the spring rod lock nuts (acorn-type). Install spring rod lock nuts and tighten.
21. If motorcycle is equipped with ride control, insert the two eye bolts (10) and (12) Illus. 153, through holes in spring fork crown; if equipped with shock absorber, insert the two bolts (T) Illus. 152, in spring fork crown. Install nuts and washers and tighten nuts securely.
22. Attach lower end of horn assembly to horn bracket on mudguard.
23. If motorcycle is equipped with mudguard lamp, tie string to wire terminal, pull wire through loom and connect wire to ignition-light switch terminal from which it was removed.
24. After assembly has been completed, check front wheel brake for correct adjustment.

### Removing Complete Fork Assembly

1. Set motorcycle on rear stand.
2. Disconnect battery negative wire at frame (ground) connection.
3. If motorcycle is equipped with spotlamps mounted on fork bracket, disconnect lamp wires and remove bracket with lamps attached.
4. If motorcycle is equipped with mudguard lamp, disconnect lamp wire from terminal on ignition-light switch and tie a piece of string approximately 30" long to wire terminal. Pull wire out of loom and untie or cut string, allowing it to extend through each end of loom. String will be used when reassembling, to pull wire back through loom.
5. Remove headlamp and disconnect its wires.
6. Disconnect all remaining wires from insulated junction terminals on horn bracket or lamp bracket, and also from horn.
7. Free cables and any wires from cable retaining clips on right and left sides.
8. Remove headlamp bracket and horn assembly.
9. Remove ride control, or shock absorber, if motorcycle is so equipped.
10. Raise front end of motorcycle high enough to permit removing front wheel and front mudguard—support motorcycle by means of suitable blocking underneath frame.
11. Remove front wheel. See "Removing Front Wheel," Page 147.
12. Remove brake assembly from left rocker plate after disconnecting brake shackle from rigid fork. Free front brake cable housing from clamp on rigid fork.
13. Remove front mudguard, after removing nuts and locks from rocker plate rear studs, and the two bolts securing mudguard to rigid fork.
14. If motorcycle is equipped with steering damper, remove lock nut from steering damper rod, then remove upper end parts in the following order: adjusting nut, keyed steel washer, fiber washer, operating lever, and actuating sleeve. This entire assembly is located in the central part of the handle bar mounting bracket. Steering damper rod, cushion spring, pressure disc, fiber disc, and steel disc assembly can now be withdrawn (downward) from fork stem hole.
15. Remove handlebar lock nut and cone lock plate.
16. Loosen the two handlebar pinch bolts, and with a rawhide mallet, or a hammer and a block of wood, drive handlebars off fork ends. There will

be enough slack in throttle and spark control wires and housings without loosening or disconnecting them when driving off handlebars. After handlebars have been driven off, swing them to left side of motorcycle and let them hang by control wire housing, placing cloth or other suitable padding as needed, to protect finish.

17. Remove upper head cone (adjusting cone) from fork stem, thereby freeing fork assembly for removal from frame head. When removing fork assembly, be careful that none of the balls in head cups drop out and become lost. Remove all balls from head cups.

### Disassembling and Assembling Forks

1. Clamp fork stem in suitable vise.
2. Remove rocker plates.
3. If forks have spring rod bushing retaining plate, remove bolt from center of plate.
4. With suitable "C" clamp, decompress fork recoil springs and remove nuts from ends of spring rods.
5. Decompress cushion springs and spring fork is then free for removal.
6. Assemble forks in reverse order of disassembly. See paragraph 13, under "Installing Spring Fork," Page 153.

### Installing Complete Fork Assembly

1. Thoroughly clean and inspect balls, cones and head cup ball races. If any are found worn or damaged, renew.
2. Put a liberal amount of Harley-Davidson grade "A" grease in each head cup and then place 17 balls in each cup. Insert fork stem through frame head and install upper head cone (adjusting cone). Adjust head cone so there is no perceptible shake in bearing; however forks must turn freely.

3. Drive handlebars onto fork ends, using a rawhide mallet, or a hammer and a block of wood.  
Install cone lock plate, entering pin through hole in handlebars and engaging a notch in adjusting cone. Install and tighten handlebar nut securely. *When tightening this nut, always make sure that register on nut enters hole in lock plate and handlebars. Check steering head bearing adjustment, as tightening lock nut may have changed this adjustment slightly. The fork must turn freely without perceptible shake. If necessary to readjust, remove handlebar lock nut and cone lock plate and turn adjusting cone, clockwise for less shake or counter-clockwise if too tight. It is not necessary to remove handlebars to turn adjusting cone; cone may be turned by tapping cone at lock pin notches with a pin punch and light hammer. Cone must be adjusted so pin on cone lock plate is free to enter hole in handlebar center forging and go on through to engage a notch in the cone. Adjusting cone lock plate and lock nut must be securely tightened for*

each check. When desired setting is obtained, tighten handlebar pinch bolts securely.

4. Install steering damper if motorcycle is so equipped. See "Steering Damper," Page 24.
5. Install front mudguard.
6. Install front brake assembly on left rocker plate, and connect brake shackle to rigid fork.
7. Install front wheel.
8. Remove blocking from underneath motorcycle frame.
9. Install headlamp bracket with its rear connection arm below handlebar lug.
10. Install ride control or shock absorber if motorcycle is so equipped. See Illus. 151 showing shock absorber installed.
11. Install horn assembly.
12. If motorcycle is equipped with mudguard lamp, tie string to wire terminal, pull wire through loom and connect wire to ignition-light switch terminal from which it was removed.
13. Connect headlamp wires and install headlamp.
14. Install spotlamps together with bracket if motorcycle is so equipped.
15. Connect all remaining wires that were disconnected before removing fork assembly. Refer to wiring diagram that applies as to model and electrical equipment.
16. Secure cables, and any wires originally secured, with retaining clips, on right and left sides.
17. Secure front brake cable housing with clamp on rigid fork.
18. After assembly has been completed, check front wheel brake for correct adjustment.

### Memoranda



## FORK, FRAME AND HANDLEBAR ALIGNMENT

### Rough Check for Fork Alignment

Obtain a perfectly straight  $7/16''$  diameter round bar about 30" long. Turn down one end of rod to  $3/8''$  diameter for a distance of approximately 1".

Rough check rigid fork for alignment as follows: Temporarily install a steering damper screw in fork stem upper end. Referring to Illus. 146, pass  $7/16''$  bar through hole in fork center stem with  $3/8''$  diameter end entering hole in steering damper screw to determine if fork sides are parallel with center stem. As shown in illustration the fork side tips should be  $3-45/64''$  from the sides of test bar.

Upper end fork sides and fork stem must be spaced to fit handlebar mounting holes.

Fork sides can be checked for relative alignment by using two perfectly straight  $5/16''$  diameter round bars at least 18" long. Referring to Illus. 147, note that fork is to be supported in horizontal position on level blocks or by clamping center stem in a vise. Insert one rod through holes in lower fork tips and lay the other squarely across upper end of forks. Sight across the two rods and note their relative alignment. If they are not in close alignment, either one or both of the fork sides are not straight, or possibly the fork sides are straight enough, but they are out of alignment with each other, or across the fork, due to a twist in the fork crown.

This method of checking fork alignment is recommended only in connection with emergency repair. Except in emergency, fork straightening and aligning should be referred to a shop where any needed straightening equipment and more accurate aligning gauges are available.

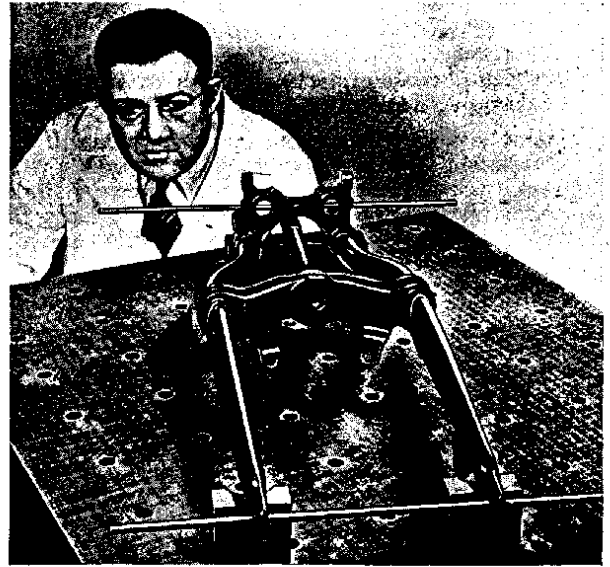

ILLUS. 147  
VISUAL CHECK OF FORK SIDE RELATIVE ALIGNMENT

### Rough Check for Frame Alignment

Sketch (Illus. 148) shows a satisfactory method of rough checking a frame that is not visibly badly damaged but there is doubt as to its possible alignment. This check will determine whether or not frame is far enough out of alignment to require either a major re-aligning job or replacement. Straightening a badly bent frame requires special tools and fixtures for holding, bending and gauging.

The straight edge must be perfectly straight and can be either a 1" rod, or a rectangular bar 1" wide and  $1/2''$  thick or of sufficient thickness so that it is rigid. Its length should be 65" or more.

The gauge rod can be any straight  $3/8''$  diameter —24 thread rod at least 6" long. It is to be installed in transmission mounting plate left rear bolt hole.

The shim must be  $5/16''$  thick and approximately 3" long. It is to be inserted between straight edge and  $3/8''$  gauge rod.

The round bar for head must be  $1-3/64''$  in diameter and at least 32" long. A shoulder or pin may be provided at top end of bar to prevent it from passing all the way through frame head. Bearing cups are left in frame head when using gauge bar.

Sketch includes measurements for checking alignment.

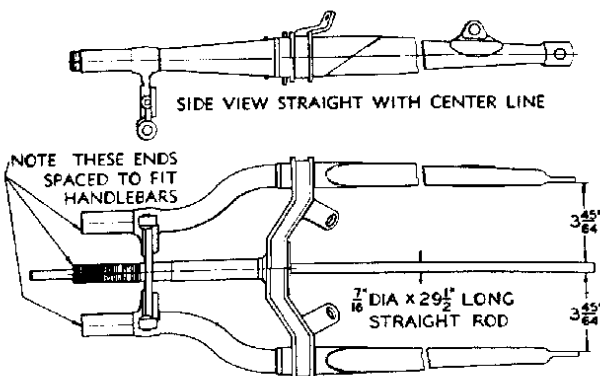

ILLUS. 146  
CORRECT ALIGNMENT OF FORK SIDES WITH FORK STEM



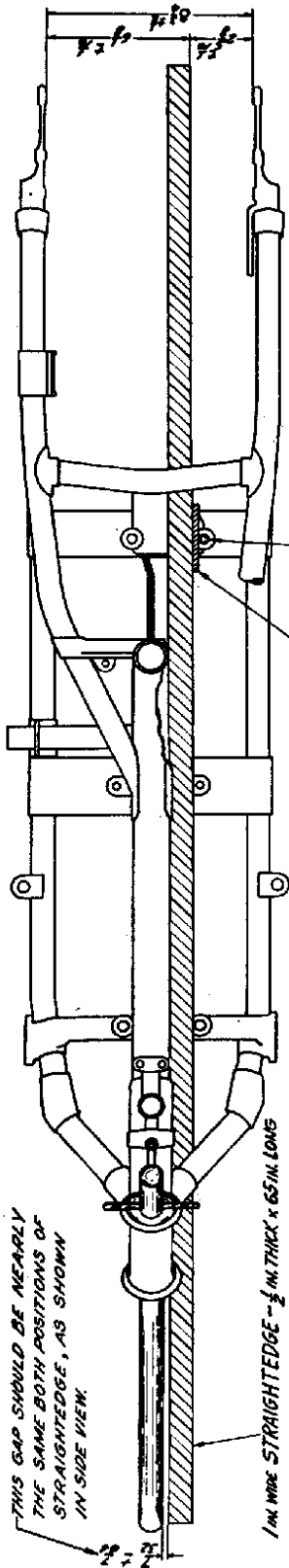

3/8" DIA STRAIGHT ROD, 6 INCHES LONG, BEND THIS AT LEAST 3/4" IN LONG ON ONE END. (AS MODEL FRONT AXLE PART MS-3810-30 WILL DO) ROD MUST BE SCREWED TIGHT INTO LEFT REAR TRANSMISSION SUB MOUNTING PLATE CAP SCREW HOLE.

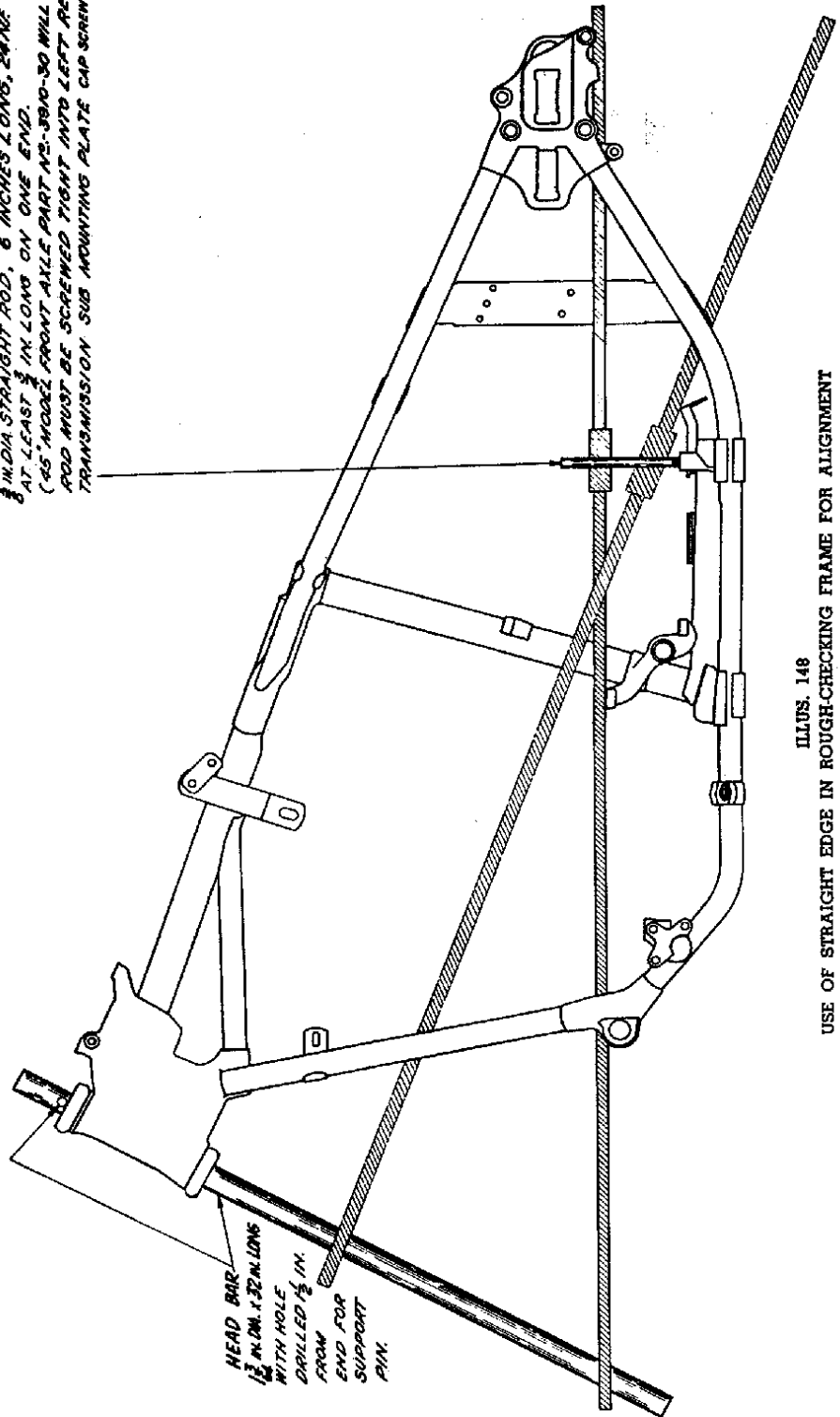

ILLUS. 148  
USE OF STRAIGHT EDGE IN ROUGH-CHECKING FRAME FOR ALIGNMENT

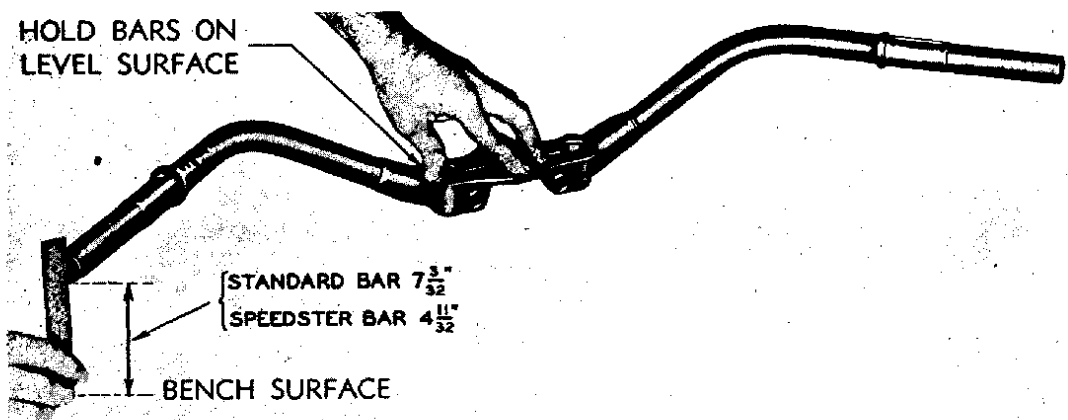

ILLUS. 149  
CHECKING HEIGHT OF HANDLEBAR ENDS



ILLUS. 150  
CHECKING WIDTH OF HANDLEBAR ENDS

### Rough Check for Handlebar Alignment

To disassemble handlebar as necessary for checking and straightening, see "Servicing Handlebar Controls," Page 25.

If handlebar is not bent sufficiently to kink, fracture or weaken the tubing, it can be aligned by first mounting the handlebar bracket rigidly and then bending the bar back in shape. Illus. 149 and 150 show alignment specifications for "Standard" and "Speedster" handlebar.

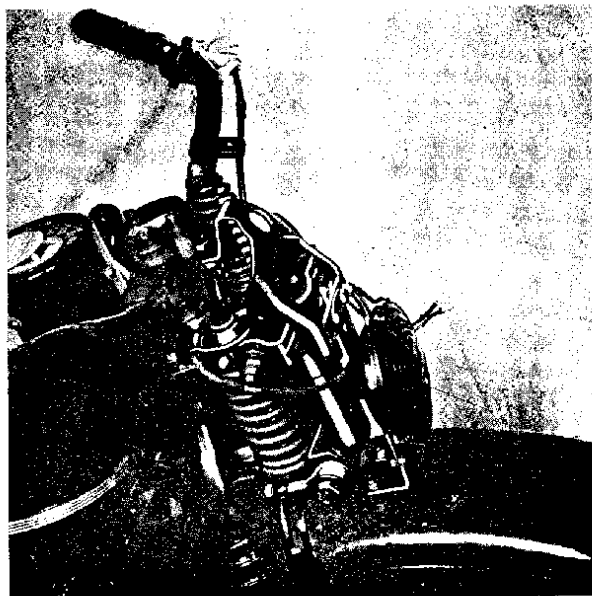

ILLUS. 151  
HYDRAULIC SHOCK ABSORBER INSTALLED ON MOTORCYCLE

## SHOCK ABSORBER ASSEMBLY

(Item letters Refer to Illus. 152)

NOTE: Items on unlettered side are a duplicate of items on lettered side, and total number of items for both sides are given under "NUMBER USED."

ITEM	NUMBER USED	PART NUMBER	NAME
A	1	14001-45	Shock Absorber (less all fittings)
B	8	0127	Shock Absorber Stud Nut (same as Items J, K and O)
C	8	0261	Lock Washer (same as Item I, L and P)
D	6	14006-45	Plain Washer (same as Items F and S)
E	4	14002-45	Shock Absorber Rubber Bushing (same as Item R)
F	See Item D and S		.....
G	2	14003-45	Shock Absorber Upper Stud
H	2	4703-38A	Wire Clamp
I	See Items C, L and P		.....
J	See Items B, K and O		.....
K	See Items B, I and O		.....
L	See Items C, I and P		.....
M	2	0224	Plain Washer
O	See Items B, J and K		.....
P	See Items C, I and L		.....
Q	2	14004-45	Eye Bolt
R	See Item E		.....
S	See Items D, and F		.....
T	2	14005-45	Shoulder Bolt

The Harley-Davidson Monroe shock absorber cannot be satisfactorily serviced or repaired by Harley-Davidson dealers—nor is this service available at service stations handling Monroe equipment.

"Shop Dope" bulletin No. 258 explains how shock absorber service is handled.

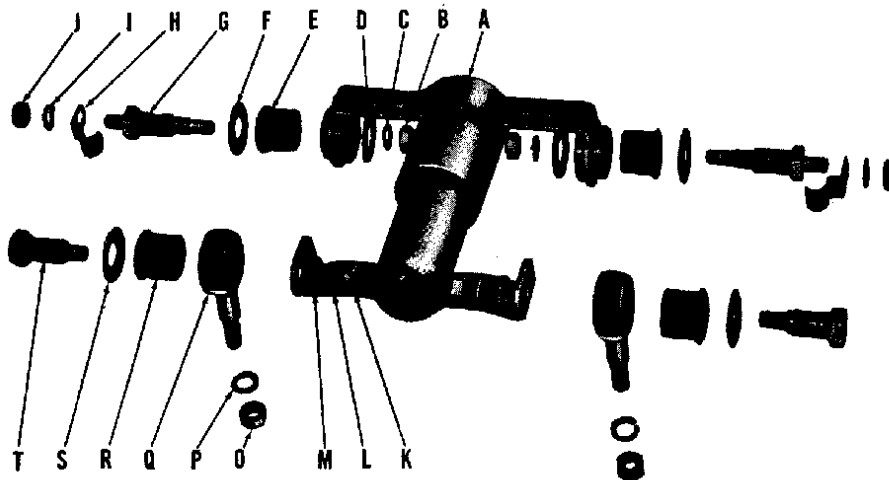

ILLUS. 152  
HYDRAULIC SHOCK ABSORBER DISASSEMBLED

RIDE CONTROL DISASSEMBLED

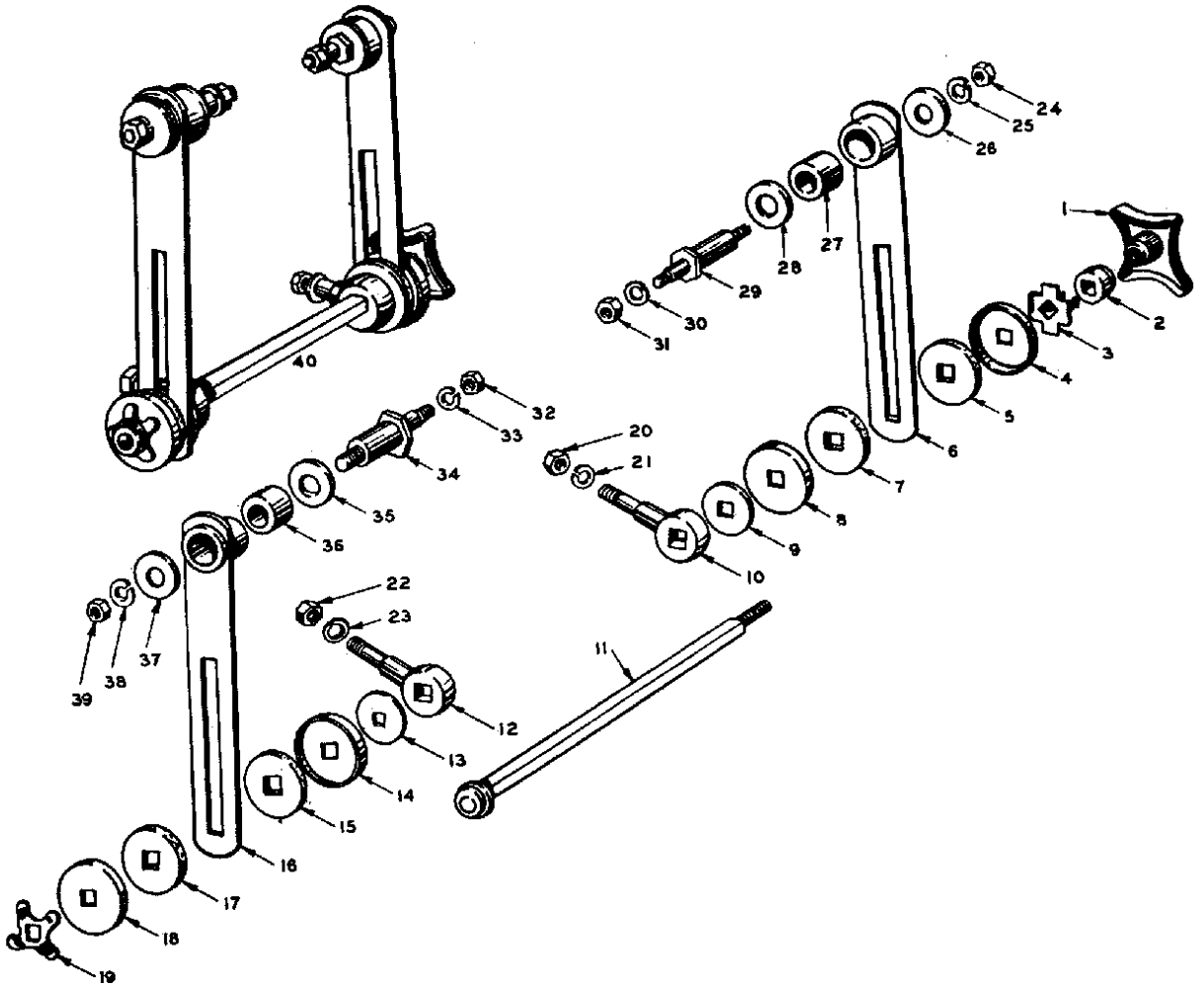

ILLUS. 153  
RIDE CONTROL DISASSEMBLED

## RIDE CONTROL ASSEMBLY

(Item Numbers Refer to Illus. 153)

ITEM	NUMBER USED	PART NUMBER	NAME
1	1	13440-33	Adjusting Wheel
2	1	13444-33	Adjusting Wheel Collar
3	1	13442-33	Adjusting Wheel Spring Clip
4	4	13430-33	Friction Disc Cup (same as Items 8, 14 and 18)
5	4	13431-33	Friction Disc (same as Items 7, 15 and 17)
6	2	13456-36	Side Plate (same as Item 16)
7	See Items 5, 15 and 17		.....
8	See Items 4, 14 and 18		.....
9	2	13438-36	Rod Friction Washer (same as Item 13)
10	2	13436-36	Adjusting Rod Eyebolt (same as Item 12)
11	1	13435-36	Adjusting Rod
12	See Item 10		.....
13	See Item 9		.....
14	See Items 4, 8 and 18		.....
15	See Items 5, 7 and 17		.....
16	See Item 6		.....
17	See Items 5, 7 and 15		.....
18	See Items 4, 8 and 14		.....
19	1	13437-33	Adjusting Rod Spring Washer
20	6	0129	Nut (same as Items 22, 24, 31, 32 and 39)
21	6	0261	Lock Washer (same as Items 23, 25, 30, 33 and 38)
22	See Items 20, 24, 31, 32 and 39		.....
23	See Items 21, 25, 30, 33 and 38		.....
24	See Items 20, 22, 31, 32 and 39		.....
25	See Items 21, 23, 30, 33 and 38		.....
26	2	13457-40	Plate Stud Plain Washer (same as Item 37)
27	2	13454-33	Rubber Bushing (same as Item 36)
28	2	13458-36	Plate Stud Washer (same as Item 35)
29	2	13457-36	Side Plate Stud (same as Item 34)
30	See Items 21, 23, 25, 33 and 38		.....
31	See Items 20, 22, 24, 32 and 39		.....
32	See Items 20, 22, 24, 31 and 39		.....
33	See Items 21, 23, 25, 30 and 38		.....
34	See Item 29		.....
35	See Item 28		.....
36	See Item 27		.....
37	See Item 26		.....
38	See Items 21, 23, 25, 30 and 33		.....
39	See Items 20, 22, 24, 31 and 32		.....
40	..... 11250-36		Ride Control (complete)

### REMOVING AND INSTALLING SPEEDOMETER HEAD AND DRIVE CORE

#### Removing Speedometer Head and Drive Core

In order to lubricate speedometer drive core, or renew a damaged or broken core, speedometer head must first be removed.

1. Remove instrument panel cover.
2. Remove the two screws that secure speedometer head to instrument panel base.
3. Lift speedometer head as far as core housing will permit, and with suitable pliers remove housing coupling nut from speedometer head.

After speedometer head has been removed, core can be withdrawn from housing.

#### Installing Speedometer Head and Drive Core

1. Remove housing coupling nut from speedometer drive unit.
2. Install core in housing from top end and engage squared lower end of core in speedometer drive shaft.
3. Connect housing lower end to speedometer drive unit and tighten coupling nut securely.
4. Connect speedometer head to housing upper end engaging squared upper end of core in speedometer shaft and tighten coupling nut securely.
5. Install speedometer head.
6. Install instrument panel cover.



## SIDECAR

### Removing Sidecar From Motorcycle

Set motorcycle on rear stand. Disconnect brake rod from brake shaft lever. If sidecar is equipped with any lamps, disconnect the wires from their respective terminals.

Loosen ball joint lock nuts and ball joint nuts. Remove cotter pin, nut, spring and washers from frame brace upper front connection on motorcycle. Loosen the four sidecar frame brace lower clamp screws enough to allow disconnecting brace from upper front connection on motorcycle. Place blocks of suitable height under chassis to support it while disconnecting ball joint nuts from rear and front connections on motorcycle.

### Attaching Sidecar to Motorcycle

Set motorcycle on rear stand near sidecar chassis. Put a small amount of grease in each ball socket. Block up chassis so that front and rear connections are as close as possible to, and nearly of the same height as motorcycle connections. Make sure ball joint nut lock nuts are loose on ball joint nuts.

Make front connection first, then rear connection. Due to previous slight misalignment, it may be necessary to loosen rear ball socket bracket nuts and shift bracket slightly before rear connection can be made. After rear connection has been made, tighten bracket nuts securely, and insert cotter pins.

When ball joints are properly adjusted, there will be flexibility between motorcycle and sidecar chassis, but no play in joints. Tighten ball joint nut until it just bottoms; and then back off about 1/8 turn. Hold ball joint nut in this position with one wrench and tighten ball joint nut lock nut securely with another wrench. After both ball joints have been properly adjusted and locked, push motorcycle off rear stand.

Put a small amount of grease on upper front connection and attach brace to upper front connection on motorcycle. Install larger washer, spring, smaller washer and nut; turn nut on until end of connection bolt just protrudes through nut and insert cotter pin.

Adjust sidecar frame brace so motorcycle leans about 2 degrees away from sidecar. It is of prime importance that this adjustment be carefully made, as it affects steering. With adjustment correct, motorcycle will have no appreciable tendency to pull to either right or left when driven on a level highway. Tighten frame brace lower clamp screws securely.

Connect brake rod to brake shaft lever. If brake needs readjusting, see "Adjusting Brakes", Page 20.

Connect any lamp wires to their respective terminals—see "Sidecar Wiring Diagrams," this Page, and Page 163.

Note: If a new sidecar is to be attached to a motorcycle not previously equipped with one, follow instructions included with sidecar.

### Adjusting Brake

See "Adjusting Brakes," Page 20.

### Servicing Brake

See "Servicing Brakes," Page 20.

### Removing Wheel

See "Removing Sidecar Wheel," Page 147.

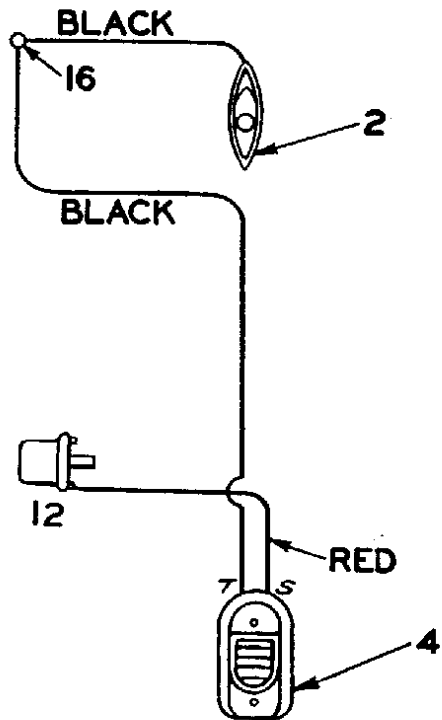

ILLUS. 154

### Wiring Diagram

(1940 to Early 1947 Model Sidecar)

#### Connections

2. MUDGUARD LAMP—Black wire from junction terminal (16).

4. TAIL AND STOP LAMP—Red wire from stop lamp switch (12); black wire from junction terminal (16).

12. STOP LAMP SWITCH (on motorcycle)—Red wire from sidecar tail and stop lamp (4).

16. JUNCTION TERMINAL (in left side of motorcycle frame under saddle)—Black wire from mudguard lamp (2); black wire from sidecar tail and stop lamp (4).

## Wiring Diagram

(Later 1947 Model Sidecar)

A. TWO WIRE CABLE—Green wire; red wire.

### Connections

2. MUDGUARD LAMP—Green wire from junction terminal (5).

4. TAIL AND STOP LAMP—Cable "A" red wire stop lamp switch (12); black wire from junction terminal (5).

5. JUNCTION TERMINAL—(in sidecar mudguard)—Cable "A" green wire from junction terminal (16); black wire from tail and stop lamp (4); green wire from mudguard lamp (2).

12. STOP LAMP SWITCH (on motorcycle)—Cable "A" red wire from tail and stop lamp (4).

16. JUNCTION TERMINAL (in left side of motorcycle frame under saddle)—Cable "A" green wire from junction terminal (5).

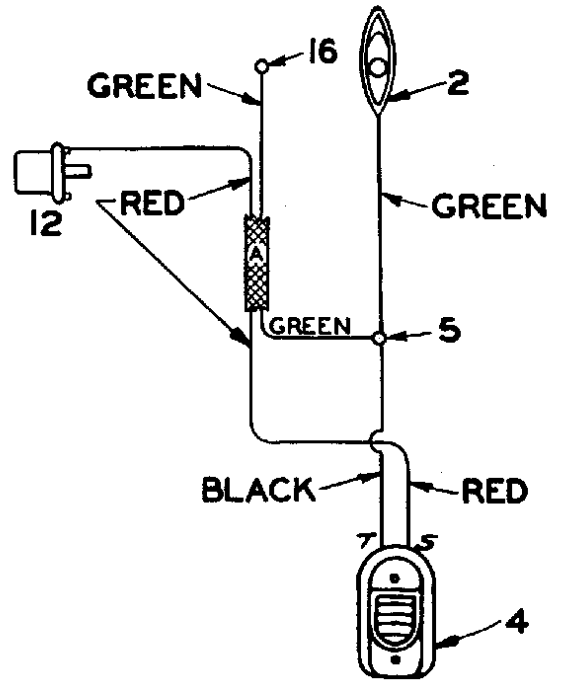

ILLUS. 155

### WIRING DIAGRAM

(Later 1947 Model Sidecar)

## ALIGNING GAS SHUT-OFF VALVE FITTINGS

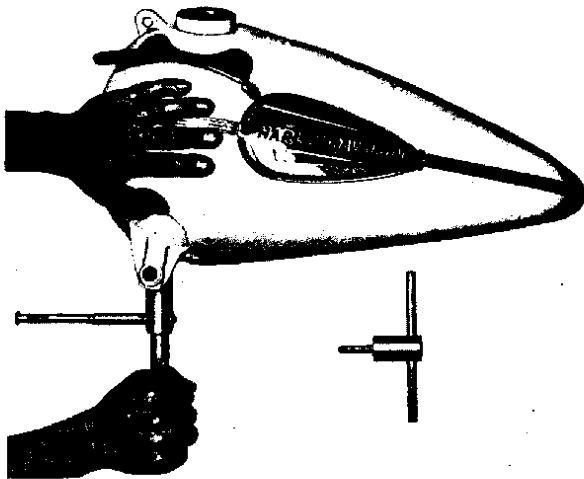

ILLUS. 156

### ALIGNING GAS SHUT-OFF VALVE FITTINGS

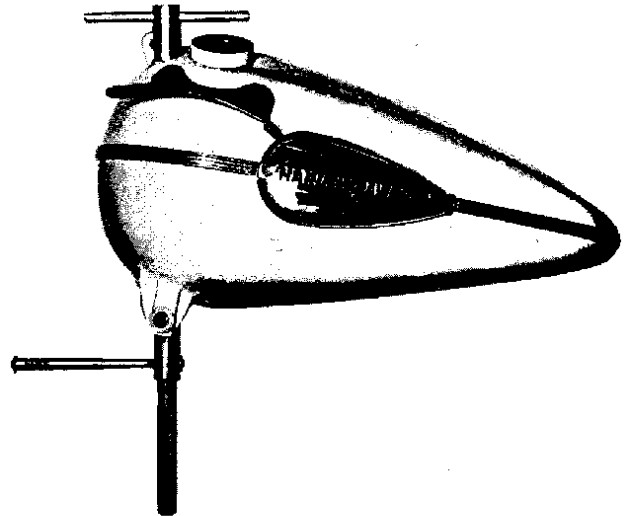

ILLUS. 157

### SPACING GAS SHUT-OFF VALVE FITTINGS

Note: Instructions for aligning and spacing gas valve fittings are included with Harley-Davidson gas shut-off valve aligning tool, Part No. 12775-42.

# INDEX

	Page	Page	
Air Cleaner Assembly Illustration .....	10	Electrical System .....	96
Air Cleaner, (Mesh Pack Type) .....	10	Engine Overhauling .....	37
Air Cleaner, (Oil Bath Type) .....	10	Engine, Disassembling for Top Overhaul Only —	
Alignment, Fork, Frame and Handlebar .....	156	<i>O.H.V. Engine</i> .....	37
Aligning, Gas Shut-off Valve Fittings .....	163	<i>Side Valve Engine</i> .....	40
Battery, Care of .....	106	Engine, Removing (Assembled) .....	41
Bearings, Engine Main .....	59, 60	Engine, Disassembling for Complete Overhaul —	
Bearings, Connecting Rod Lower .....	60, 61	<i>O.H.V. Engine</i> .....	43
Brake, Front Wheel, Assembly Illustration.....	18	<i>Side Valve Engine</i> .....	43
Brake, Rear Wheel, Assembly Illustration.....	19	Engine, Fitting and Reassembling .....	45
Brake, Front and Rear Wheel Assembled, illustration .....	20	Engine, Installing .....	87
Brakes, Adjusting .....	20	Engine, Starting .....	5
Brakes, Servicing .....	20	Engine, To Stop .....	5
Breather Valve, Timing (Side Valve Engine)....	70	Engine, Running in New .....	5
Bushings, Connecting Rod Upper .....	90	Engine Serial Number .....	3
Bushings, Cam Gear Shaft —		Flutter Valve, Servicing (Side Valve Engine)....	54
<i>O.H.V. Engine</i> .....	53	Flywheels, Servicing and Installing Crank Pin..	60
<i>Side Valve Engine</i> .....	54	Flywheels, Assembling .....	61
Carburetor, Adjusting .....	21	Flywheels, Truing .....	62
Carburetor, Servicing .....	120	Forks, Removing and Installing .....	153
Chains, Adjusting .....	12	Gear Ratios, Standard .....	4
Chains, Lubricating .....	12	Gear Shifter Control, Checking and Adjusting..	14
Chains, Repairing .....	14	Generator Assembly Illustrations .....	92, 94
Circuit Breaker Assembly Illustrations.....	80, 81	Generator, Removing .....	97
Circuit Breaker, Removing —		Generator, Testing .....	97 to 99, and 101
<i>O.H.V. Engine</i> .....	43	Generator, Disassembling .....	99
<i>Side Valve Engine</i> .....	44	Generator, Reassembling .....	102
Circuit Breaker .....	43, 44, 79, 80, 81, 82	Generator, Installing .....	64, 103
Circuit Breaker, Servicing .....	80	Generator Charging Rate .....	103
Circuit Breaker, Installing and Timing Ignition.	81, 82	Handlebar Controls, Servicing .....	25
Clutch Assembly Illustration .....	146	Handlebars, Straightening .....	158
Clutch, Spring Tension, Adjusting .....	16	Handlebar Grip Assembly Illustration .....	25
Clutch, Disassembling .....	16, 17	Headlamp, Adjusting .....	110
Clutch, Reassembling .....	17	High Speed Tips .....	6
Clutch Control, Checking and Adjusting .....	15	Horn .....	110
Clutch Hub, Removing .....	136	Ignition Coil .....	107
Clutch, Installing .....	142	Ignition Timing—by Piston Position .....	86
Commutator, Cleaning .....	103	Lamp Bulbs .....	111
Connecting Rods, Aligning .....	83	Legend for o.h.v. engine oiling and breather system .....	30
Control Cable, Front Brake, Replacing.....	26	Lubrication, Commutator End Armature Bearing	105
Control Wire, Throttle and Spark, Replacing....	25	Lubricants—Types to Use .....	9
Crankcases, Assembling .....	63	Lubrication Chart .....	9
Cylinders, Reboring and Rehonng .....	45	Lubrication, Engine .....	33
Cylinder Head Assembly Illustration		Lubrication, General .....	8
(o.h.v. engine—rear head) .....	50	Lubrication, Transmission .....	144
Cylinder Heads, Servicing (O.H.V. Engine)....	37, 52	Maintenance, Regular Interval Inspection.....	11
Cylinders, Installing —		Motorcycle—Initial Servicing .....	10
<i>O.H.V. Engine</i> .....	84	Oil Pump, Removing (O.H.V. Engine) .....	28, 43
<i>Side Valve Engine</i> .....	85	Oil Pump, Servicing (O.H.V. Engine) .....	71, 72
Cylinder Heads Installing —			
<i>O.H.V. Engine</i> .....	86		
<i>Side Valve Engine</i> .....	87		

## INDEX — Continued

	Page		Page
Oil Pump, Installing (O.H.V. Engine).....	28, 73	Tire Inflation Pressures .....	3
Oil Feed Pump, Removing (Side Valve Engine).....	29, 43	Tires and Tubes, Removing and Installing .....	152
Oil Feed Pump, Servicing (Side Valve Engine).....	72, 73	Transmission and Clutch, Overhauling .....	126
Oil Feed Pump, Installing (Side Valve Engine).....	29, 79	Transmission Assembly Illustrations . 128, 130, 132, 134	
Oil Scavenger Pump, Removing (side valve engine) .....	44	Transmission, Removing .....	126
Oil Scavenger Pump, Servicing (side valve engine) .....	69	Transmission, Disassembling .....	136
Oil Scavenger Pump, Installing (side valve engine) .....	70	Transmission, Assembling .....	139
Oil Feed Pump, Adjusting .....	28	Transmission, Installing .....	142
Oil Pump Assembly Illustration (O.H.V. Engine).....	66	Trouble Chart .....	6
Oil Feed Pump and Scavenger Pump Assembly illustration (side valve engine) .....	68	Valve Guides —	
Piston Rings .....	89	O.H.V. Engine .....	46
Pistons, Fitting Oversize .....	45	Side Valve Engine .....	46
Pistons, Removing and Installing .....	88	Valves .....	46
Piston and Ring Service .....	87	Valve Seats .....	47
Push Rod Cover Assembly Illustration .....	23	Valve and Valve Seats, Grinding and Testing..	47
Push Rod Cover Cork Washers, Installing .....	23	Valves, Installing .....	48
Regulator, Current and Voltage .....	106	Valve Springs .....	48
Relay, Cut-Out .....	105	Valve Tappets, Adjusting —	
Ride Control Assembly Illustration .....	160	O.H.V. Engine .....	22
Saddle Spring Post Assembly Illustration.....	27	Side Valve Engine .....	23
Saddle Spring Post, Servicing .....	26	Valve Tappets and Valve Tappet Guides .....	58
Shock Absorber Assembly Illustration .....	159	Wheel Hub Assembly Illustrations .....	148, 149
Sidecar .....	162	Wheels, Removing and Installing .....	147
Signal Lights, Instrument Panel .....	5	Wheel, Spoking .....	150
Spark Plugs .....	108	Wheel, Truing .....	150
Spark Plug Cables, Replacing .....	107	Wheels, Hubs and Tires .....	147
Specifications, Carburetor .....	125	Wheel and Tire Care .....	149
Specifications, General .....	3	Wiring Diagram: Without current and voltage regulator—1946 and earlier models .....	114
Specifications, Engine .....	91	Wiring Diagram: With current and voltage regulator—1946 and earlier models .....	112
Specifications, Transmission .....	145	Wiring Diagram: Generator-battery; ignition; horn; generator and oiling system signal lights and stop lamp—1947 models .....	115
Speedometer Head and Drive Core, Removing and Installing .....	161	Wiring Diagram: Lighting system and horn—1947 models .....	116
Steering Damper .....	24	Wiring Diagram: Lighting system accessory lamps (except police pursuit lamps—1947 models .....	118
Switch, Ignition-Light, Servicing .....	110	Wiring Diagram: Generator—current and voltage regulator—battery; speedometer hand lock; police pursuit lamps and radio type coil—1947 models .....	117
Switch, Ignition-Light, Assembly Illustration... ..	109	Wiring Diagram: 1940 to early 1947 model sidecar .....	162
Tank Capacities, Gasoline and Oil .....	4	Wiring Diagram: Later 1947 Model Sidecar.....	163
Timing Gears, Installing —			
O.H.V. Engine .....	78		
Side Valve Engine .....	78		
Timing Mark, Flywheel —			
O.H.V. Engine .....	79		
Side Valve Engine .....	79		

This manual is brought to you by:

[www.magnamania.com](http://www.magnamania.com)



#### Removing gearbox cover

- Unfasten screw (1) for idle speed detent and remove coil
- Remove retaining screws from gearbox cover.
- Heat gearbox cover to 100 °C at the bearing seats.
- Place sliding sleeve, BMW No. 23 4 632, on the input shaft.
- Press off gearbox cover evenly.
- Remove ball (3) from neutral stop.
- Remove spacers (4).

Here you can find Service Manuals for over 200 different motorcycles

